

# **GTR-128/GTR-129**

## **Motorcycle/ Vehicle Tracker**

### **Quick Start Guide**



#### **GlobalSat WorldCom Corporation**

16F., No. 186, Jian 1<sup>st</sup> Rd, Zhonghe Dist.,

New Taipei City 23553, Taiwan

Tel: 886.2.8226.3799/ Fax: 886.2.8226.3899

[service@globalsat.com.tw](mailto:service@globalsat.com.tw)

[www.globalsat.com.tw](http://www.globalsat.com.tw)

#### **USGlobalSat Incorporated**

14740 Yorba Court Chino, CA 91710

Tel: 888.323.8720 / Fax: 909.597.8532

[sales@usglobalsat.com](mailto:sales@usglobalsat.com)

[www.usglobalsat.com](http://www.usglobalsat.com)

## CONTENT

1. Introduction .....	3
1.1 Introduction .....	3
1.2 Features .....	3
1.3 Hardware specification .....	4
1.4 Appearance .....	5
1.5 LED indicator .....	5
1.6 Cable description .....	6
1.7 Accessories .....	7
1.7.1 Standard Items .....	7
1.7.2 Optional Items .....	8
12V/24V Relay .....	8
2 Operation .....	9
2.1 Install the SIM card .....	9
2.2 Connect the Main Power.....	11
2.3 Switch on/off Tracker.....	11
2.4 Fix the device .....	12
3 Installation.....	14
3.1 Installing the Emergency button .....	14
3.2 Connecting ignition detection line on car .....	15
3.3 Connecting Relay .....	16
3.4 Installation reminder .....	17

## 1. Introduction

### 1.1 Introduction

GTR-128/GTR-129 is designed as a durable and multi-functional GPS/GSM/GPRS tracker. It integrates highly sensitive GPS module and quad-band GSM communication module with a powerful microcontroller that fits into a compact enclosure. The device is capable of being waterproof and ideal for use in a motorcycle, golf carts and vehicles. It is small in size and low in cost for covert and efficient tracking device. It provides real-time GPS positions anytime and anywhere with an open view to the sky, and offers precise positioning, and reports vehicle status to the server with necessary information shown on the map. Benefits such as enhanced fleet management, improved vehicle safety, emergency response, are all accomplished through the implementation of the GTR-128/GTR-129 system. The built-in GSM and GPS antennas are for easy installation without hassle.

### 1.2 Features

- New generation GPS module.
- Compact and Waterproof IP67 design
- Built-in high sensitivity GPS/GSM antennas.
- Quad-Band GSM System
- Built-in motion sensor
- AGPS support
- Support communication protocols- SMS/TCP/UDP.
- Multiple I/Os support: 1 Digital Input for custom function, 1 Digital input for optional Emergency button, 1 Analog Input for fuel sensor, 1 Digital Output for Relay, 1 Digital Input for ACC detection.
- Configuration and Firmware update via Over-The-Air
- Alert functions including Power low/ Over speed/ Movement alarms
- Tracking by preferred interval, scheduling and Geo-fence
- With magnet (GTR-128) or double side tape (GTR-129) for easy installation
- Multiple power solution

### 1.3 Hardware specification

Item	Description		
Model	GTR-128	GTR-129	
Back-up Battery	No back-up battery, but magnetic mount instead		Li-Polymer 320mAh
Unit Weight	77g		78.5g
Temperature	Operation	-30°C ~ + 70°C	-30°C ~ + 60°C (0°C ~ + 45°C for charging)
	Storage	-40°C ~ + 70°C	-40°C ~ + 60°C
Dimension	61 mm X 38 mm X 19 mm		
GPS receiver	high performance GPS chipset		
Communication	Quad-Band GSM (850/900/1800/1900 MHz)		
GPS Antenna	Built-in patch ceramics antenna		
GSM Antenna	Built-in Pi-Fa antenna		
Protocol	SMS/GPRS (TCP/UDP)		
Power	+9~36 V		
Built-in Memory	32 Mb		
Emergency Input	Negative trigger x 1		
Ignition (ACC) Input	Positive trigger x 1		
Digital Input Port	Negative trigger x 1		
Digital Output Port	Negative trigger x 1 (300 mA)		
Fuel sensor Input Port	Analog Input x 1( 0~28V), 12 bits resolution		
Sensor	Motion sensor		
Humidity	5% to 95% Non-Condensing		

## 1.4 Appearance

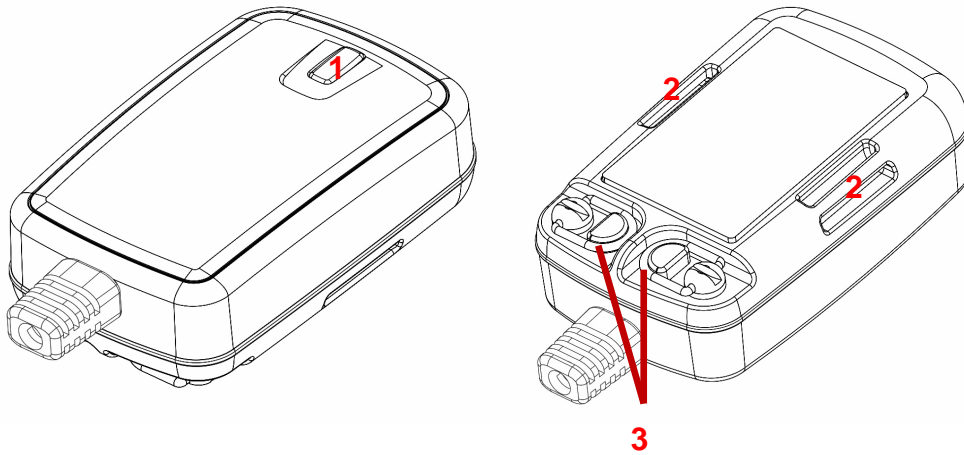

<b>1</b>	<b>LED</b>
<b>2</b>	<b>For fixing device with Velcro tape</b>
<b>3</b>	<b>Hook for screw/ unscrew back cover</b>

## 1.5 LED indicator

### Normal mode:

<b>LED status</b>	<b>Description</b>
<b>Red blinking</b>	Device is being boot and SIM card not ready
<b>Red solid</b>	SIM card ready, but GSM not registered
<b>Yellow solid</b>	GSM registered, but GPRS not connected
<b>Green solid</b>	GSM registered, and GPRS connected

**Hiding mode:** Device would blink red light while it is booting up. After completing the boot, the LED would go off.

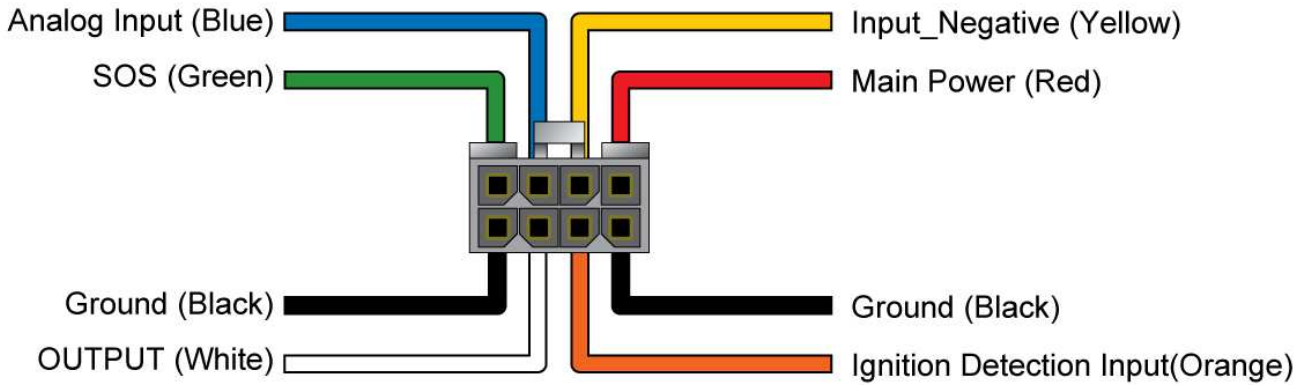

## 1.6 Cable description



Wire Color	Description
Green	<b>SOS</b> (Negative Trigger)
Blue	<b>Fuel sensor input</b> (Analog Input, 0~28 V, 12 bits resolution)
Yellow	<b>Digital Input</b> (Negative Trigger)
Red	<b>Main Power, 9~36 V</b>
Black	<b>Ground</b>
White	<b>Digital Output</b> (Negative Trigger), 300 mA
Orange	<b>Ignition Detection Input</b> (Positive Trigger)
Black	<b>Ground</b>

**1.7 Accessories**

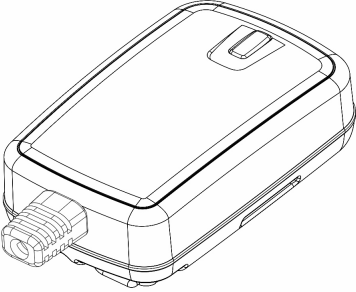
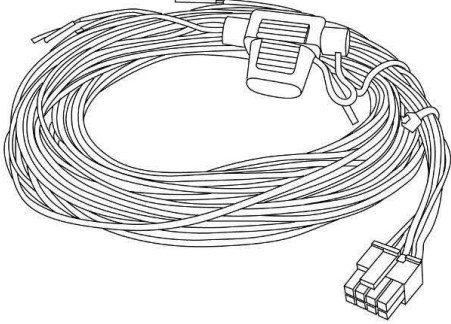
**1.7.1 Standard Items**

 <p><b>Main Unit</b></p>	 <p><b>Hardwire cable</b></p>
 <p><b>Velcro Tape</b></p>	

**1.7.2 Optional Items**

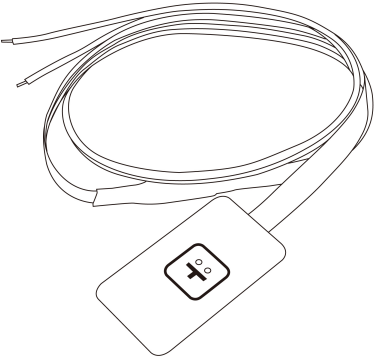
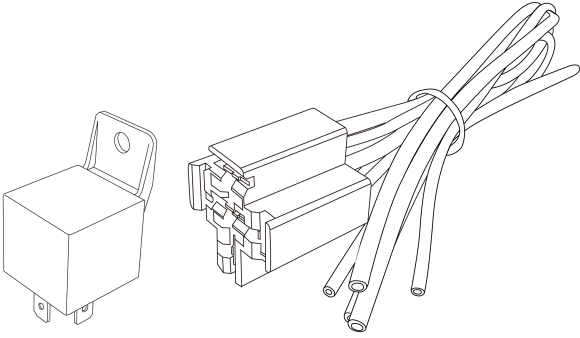
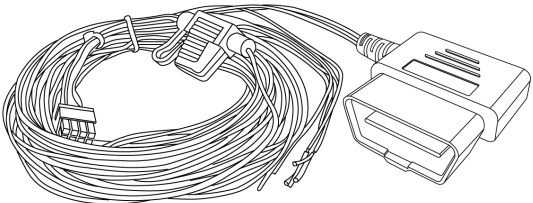
 <p><b>External Emergency Button</b></p>	 <p><b>12V/24V Relay</b></p>
 <p><b>OBDII Power Cable</b></p>	



## 2 Operation

For first time users, please follow the steps below to complete the pre-installation.

### 2.1 Install the SIM card

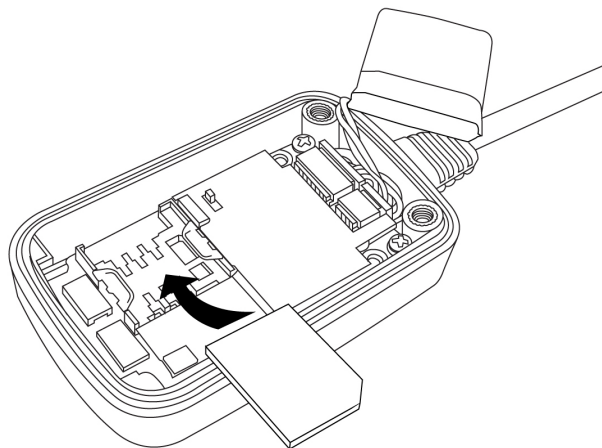

Unscrew the cover of device. Insert SIM card with the copper contacts face-down and the notch on the SIM card at the right side of the SIM slot.

**Note:** Make sure to disable the SIM PIN entry function on the SIM card before inserting your SIM card

After installing the SIM card, please follow the steps below to install the cover back.

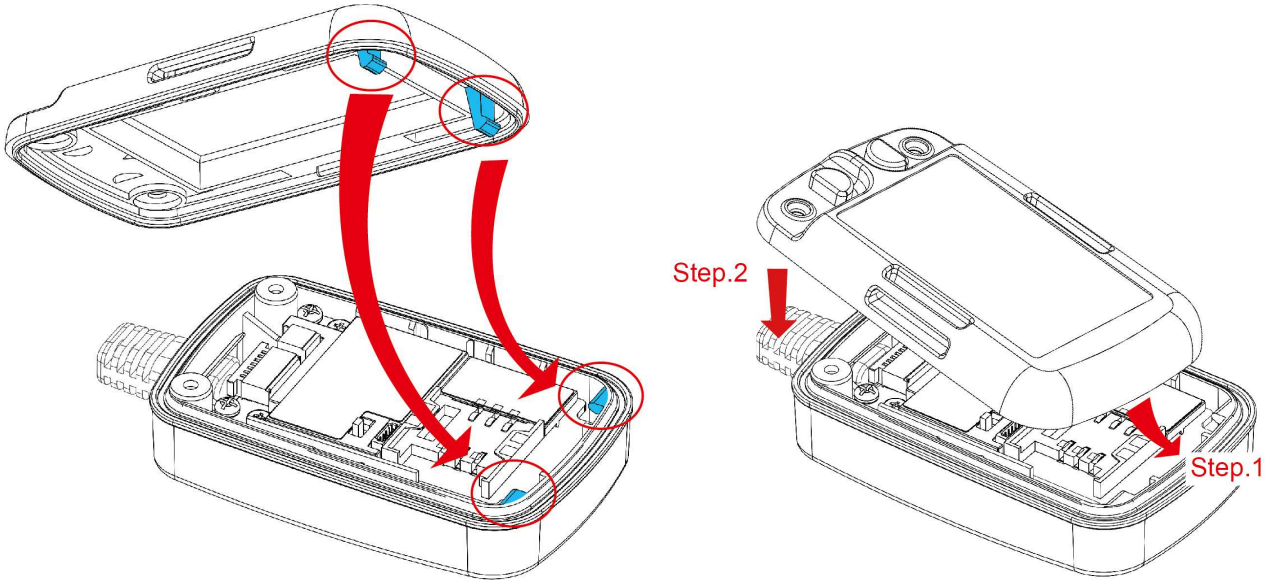

Step 1: Please align the latches of the back cover to the indentation of the device.

Step 2: Please push down the back cover to the device.

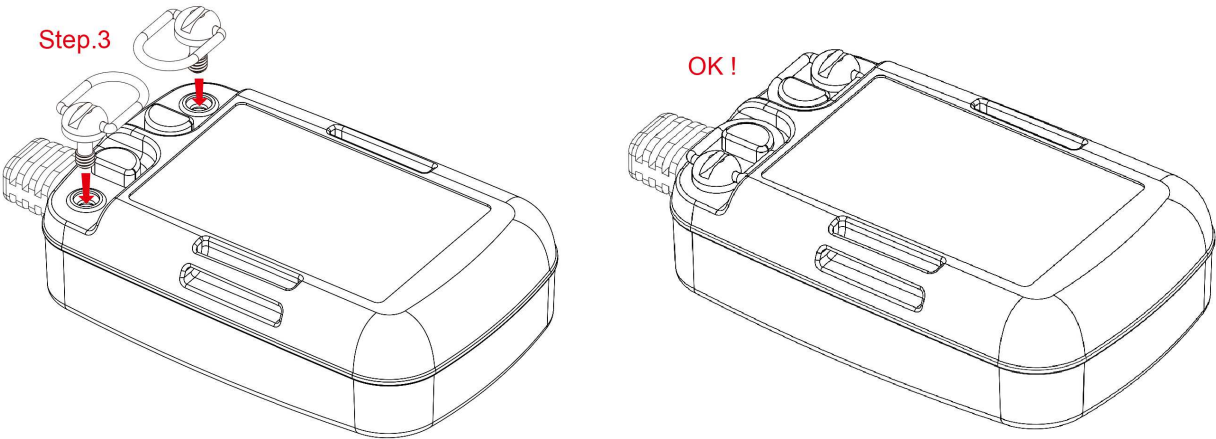

Step 3: Please screw the back cover.

## 2.2 Connect the Main Power

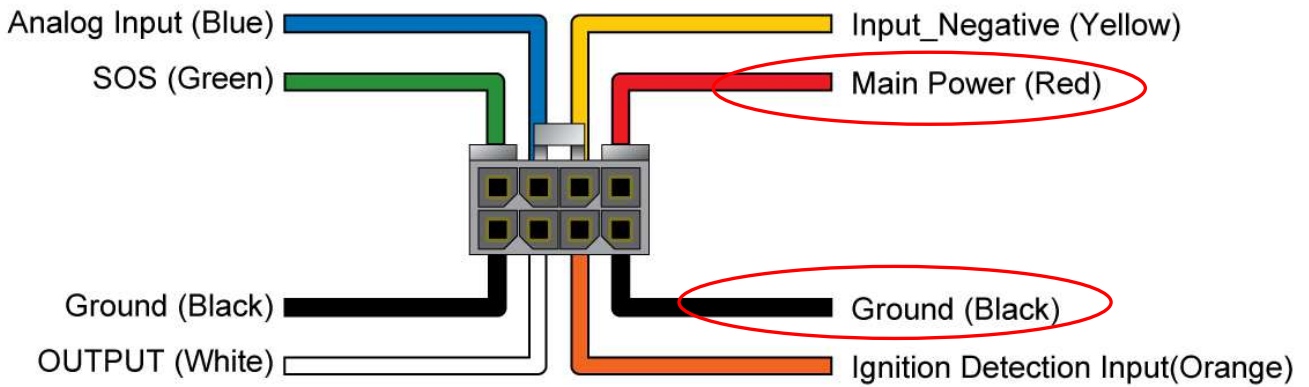

Connect the red wire from the cable to a power source of 9~36 V. Connect the black wire to ground.

## 2.3 Switch on/off Tracker

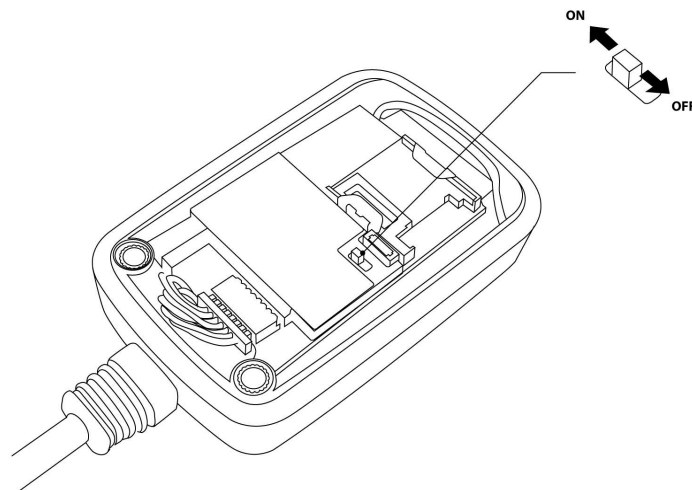

After connecting the power, please open the back cover and adjust the power switch to ON position.

**2.4 Fix the device**

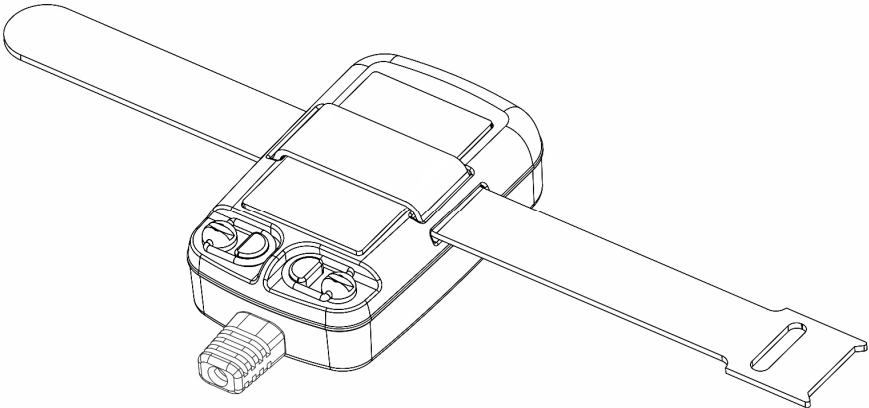

You could fix the GTR-128/GTR-129 with the Velcro tape as the picture above.

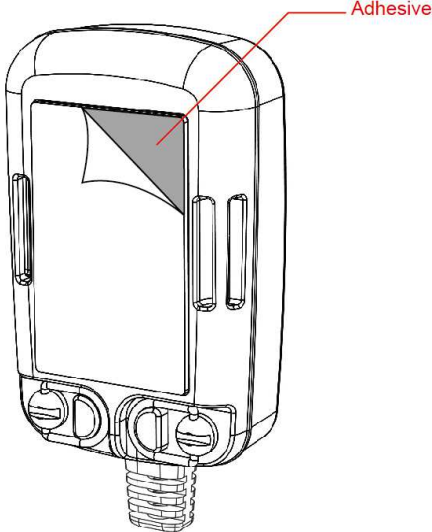

You could tear down the cover of double side tape and stick GTR-129 to the installation position.

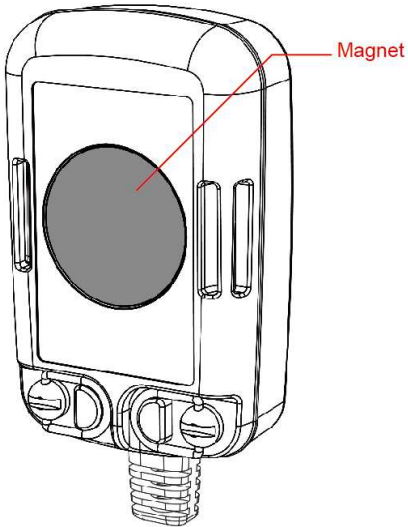

You could install the GTR-128 to a metal surface. The magnet on the device would attract the metal surface.

### 3 Installation

#### 3.1 Installing the Emergency button

There is a line of cable for connecting a push button for emergency help.

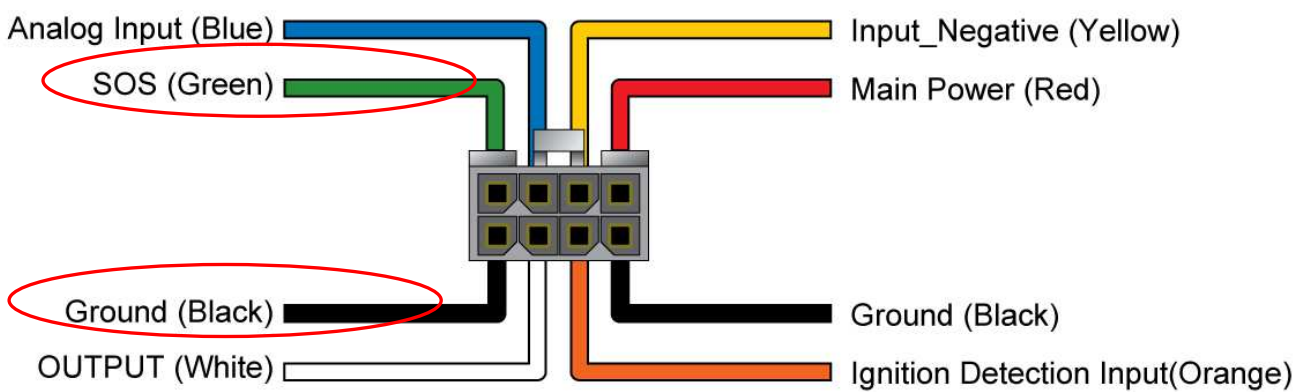

One end of the button must be connected to the SOS line and the other end must be connected to the ground line.

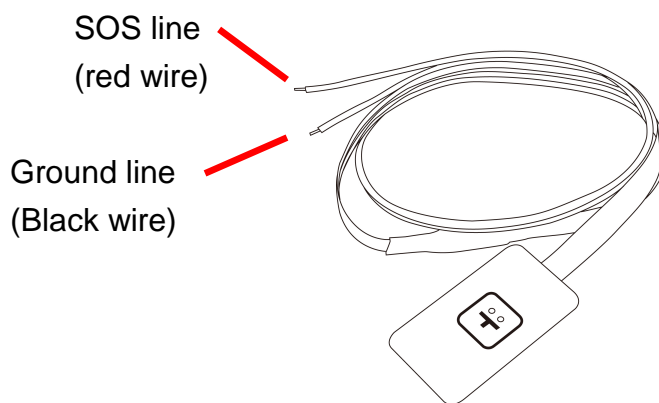

### 3.2 Connecting ignition detection line on car

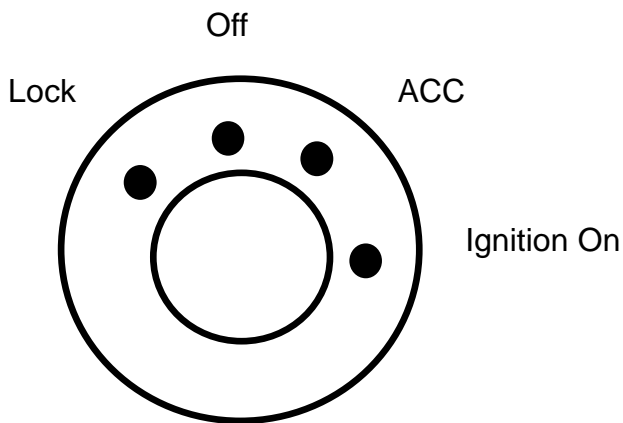
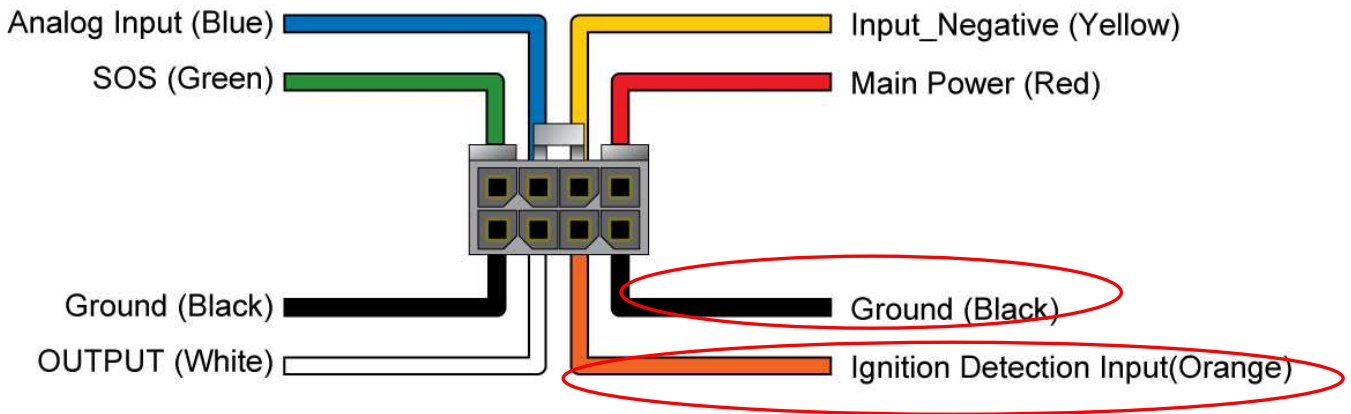

Connect the orange wire from the cable to ACC position of vehicle. Connect the black wire to ground.

### 3.3 Connecting Relay

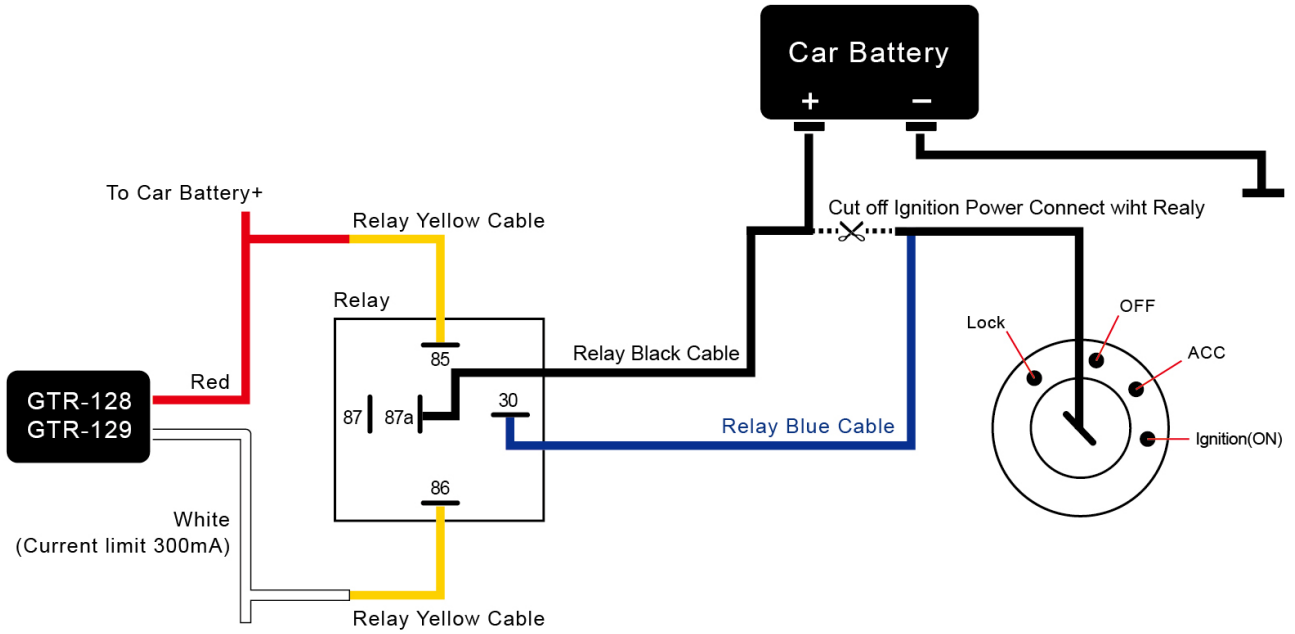

Connect the white wire from GTR-128/GTR-129's cable to the yellow wire of relay. For the other connections, please refer to the diagram above.



### 3.4 Installation reminder

**WARNING:**

In a confined space of the car, there is a big different temperature between inside and outside of the car. In addition, it is also considerable temperature difference between tracker's interior and exterior. Therefore, if you put a tracker in the car, please make sure to place it with good ventilation.

**For Vehicle:**

GTR-128/GTR-129 could be placed or installed on the marked position as the pictures below.

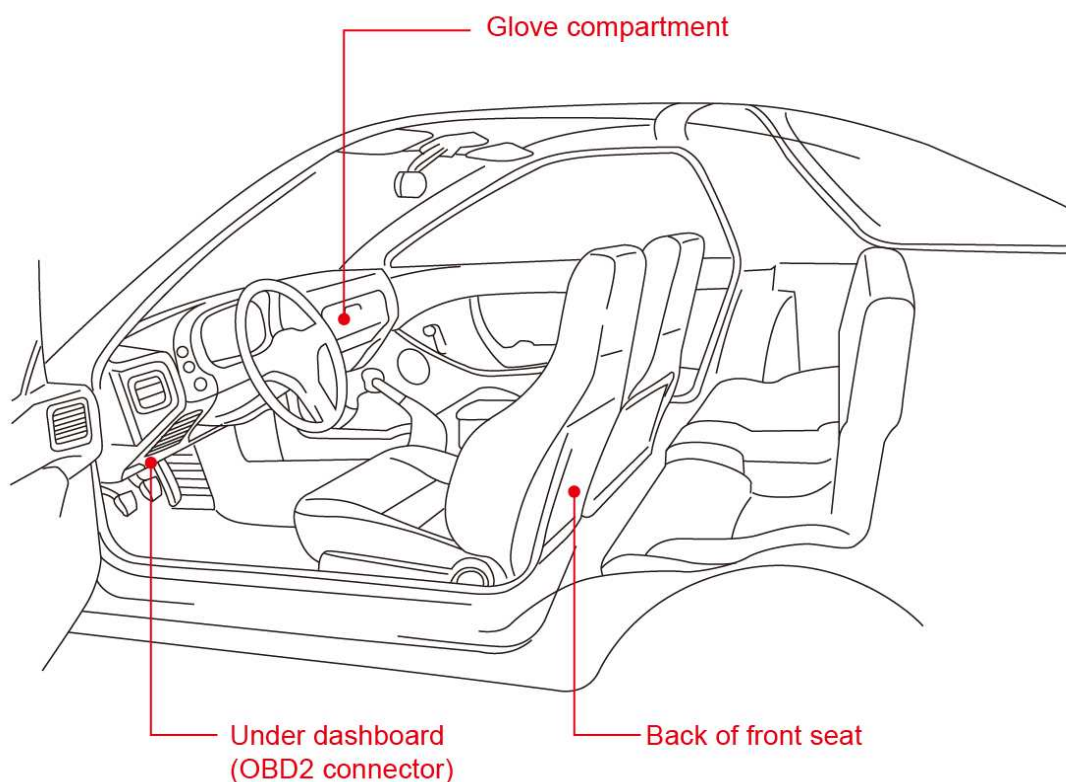

If you'd like to install GTR-128/GTR-129 at the OBDII connector of vehicles, please connect GTR-128/GTR-129 with the OBDII power cable firstly, then you could connect the OBDII power cable to the OBDII connector of vehicle as the picture below.

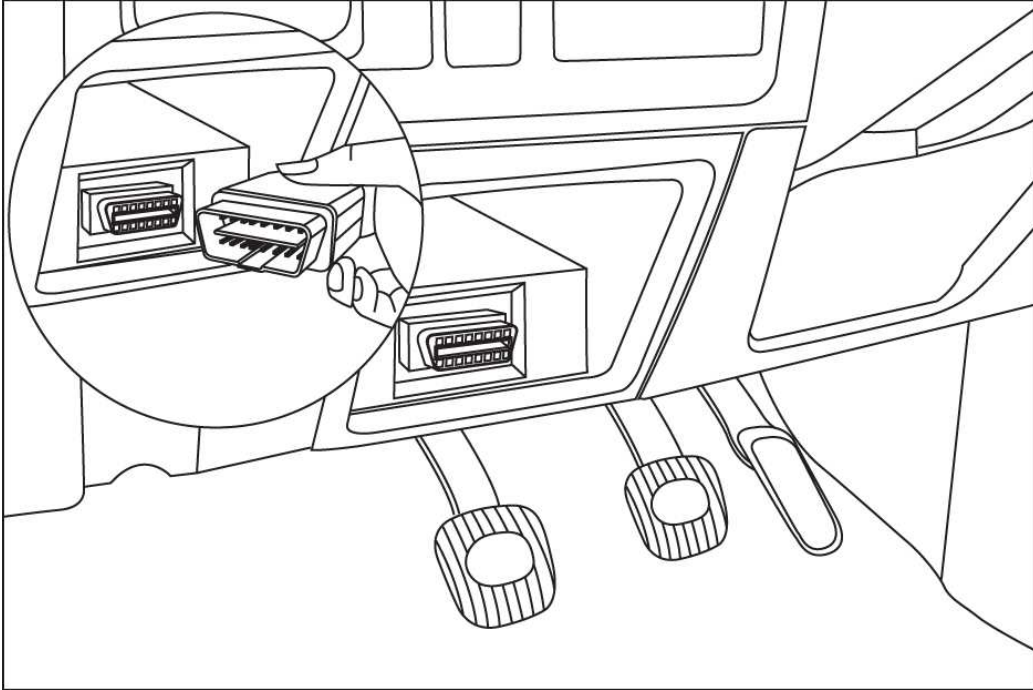

#### For Motorcycle

- For motorcycle rider, GTR-128/GTR-129 could be installed at the marked position as the picture as below.

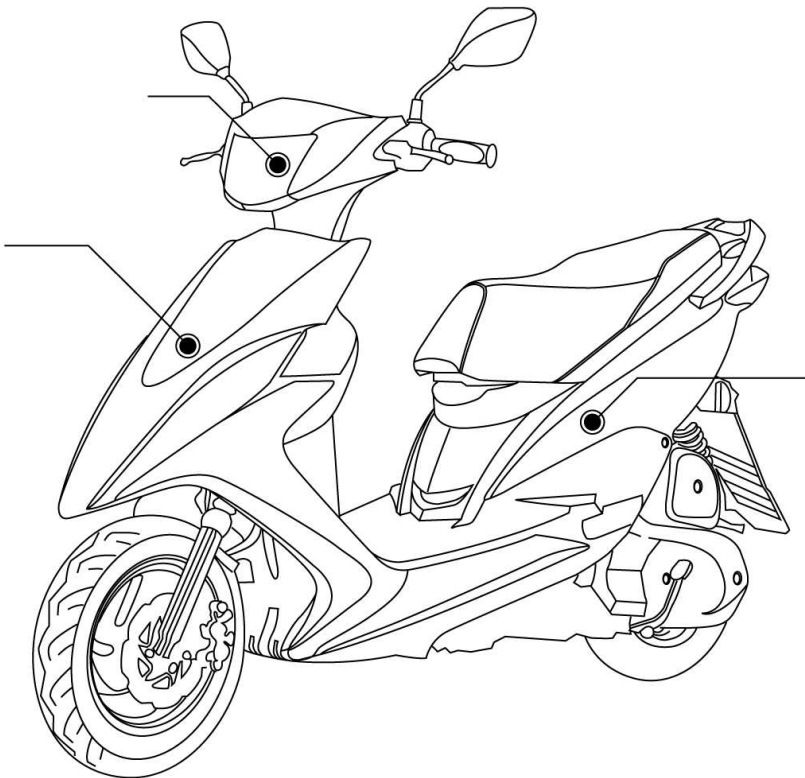

## **Federal Communication Commission Interference Statement**

This equipment has been tested and found to comply with the limits for a Class B digital device, pursuant to Part 15 of the FCC Rules. These limits are designed to provide reasonable protection against harmful interference in a residential installation. This equipment generates, uses and can radiate radio frequency energy and, if not installed and used in accordance with the instructions, may cause harmful interference to radio communications. However, there is no guarantee that interference will not occur in a particular installation. If this equipment does cause harmful interference to radio or television reception, which can be determined by turning the equipment off and on, the user is encouraged to try to correct the interference by one of the following measures:

- Reorient or relocate the receiving antenna.
- Increase the separation between the equipment and receiver.
- Connect the equipment into an outlet on a circuit different from that to which the receiver is connected.
- Consult the dealer or an experienced radio/TV technician for help.

FCC Caution: Any changes or modifications not expressly approved by the party responsible for compliance could void the user's authority to operate this equipment.

### **IMPORTANT NOTE:**

#### **Radiation Exposure Statement:**

This equipment complies with FCC radiation exposure limits set forth for an uncontrolled environment. This equipment should be installed and operated with minimum distance 20cm between the radiator & your body.

This transmitter must not be co-located or operating in conjunction with any other antenna or transmitter.