

GO MBW 1100 (WLP)

Installation Guide





GO MBW 1100 (WLP) Installation Guide

Trademarks and Licensing Agreement

© 2006-2008 GO Networks, Inc. All rights reserved.

All information contained in this document is protected by international copyright treaties. No information may be copied or reproduced without the express written consent of GO Networks Inc.

GO Metro Broadband Wireless, GO MBW, WLAN Sector Base Station, WLS, GO WLAN Pico Base Station, WLP, GO Wireless Network Controller, and WNC are all trademarks of GO Networks Inc.

Any duplication, transmission by any method, or storage in an information retrieval system of any part of this publication for other purposes other than those stated above is strictly prohibited without the specific written permission of GO Networks, Inc. This includes, but is not limited to, transcription into any form of computer system for audio, text, print, or visual retrieval. All rights under federal copyright laws and international laws will be strictly enforced.

All other trademarks and registered trademarks are the property of their respective owners.

GO Networks Inc.

1943 Landings Drive • Mountain View, CA 94043 • USA

Tel +1.650.962.2000 • Fax +1.650.962.2010

Email support@gonetworks.com

FCC Compliance Status

The following information is for FCC compliance:

This device complies with Part 15 of the FCC Rules. Operation is subject to the following conditions:

1. This device may not cause harmful interference, and
2. This device must accept any interference received, including interference that may cause undesired operation.

This equipment has been tested and found to comply with the limits of a Class B digital device, pursuant to Part 15 of the FCC Rules. These limits are designed to provide reasonable protection against harmful interference when the equipment is operated in a residential environment, this equipment generates, uses, and radiates radio frequency energy, and if not installed and used in accordance with the instructions, may cause harmful interference. However, there is no guarantee that interference will not occur.

To meet regulatory restrictions, the outdoor access point must be professionally installed.

The Part 15 radio device operates on a non-interference basis with other devices operating at this frequency when using its antennas. Any changes or modifications not expressly approved by GO Networks could void the user's authority to operate the equipment.

The antennas used for this transmitter must not be co-located or operating in conjunction with any other antenna or transmitter.

Table of Contents

Introduction	1
Key Product Features	1
Organization of this Document.....	2
GO MBW 1100 (WLP).....	3
MBW 1100 (WLP) Package Components.....	3
MBW 1100 (WLP) Safety Information.....	4
RF Exposure.....	4
MBW 1100 (WLP) Lightning Protector.....	4
Information de sécurité pour MBW 1100 (WLP).....	5
Exposition aux fréquences RF.....	5
Paratonnerre pour MBW 1100 (WLP).....	5
Installation	6
Installation Process.....	6
Site Survey	6
Assembling and Mounting.....	7
Mounting Brackets	9
Mounting the MBW 1100 (WLP)	12
Mounting the Antenna.....	13
Cable Connections	14
Cable Installation Tools.....	16
Grounding Cable.....	17
Ethernet Connection	18
Power Connection	18
Console Connection	19
Power Up and Software Configuration.....	20
Appendix A: List of Acronyms	21
Appendix B: Wiring Specifications	23

Introduction

GO Networks' MBW 1100 (WLP) device is a key enabler for the Metro Broadband Wireless (MBW) Solution. GO Pico Cellular WiFi architecture offers a novel topology for metro WiFi networks, which relies on the strengths of innovative XRF™ architecture. This architecture provides the coverage, capacity, and scalability required to deliver next-generation services and overcome the limitations of existing metro WiFi solutions.

The GO Networks' Pico Cellular WiFi architecture is a highly scalable Micro/Pico topology which provides unprecedented flexibility to service providers deploying Metro WiFi networks.

Key Product Features

- Robust Pico cellular WiFi solution
- Separate access & backhaul radios delivering unmatched bandwidth
- xRF™ smart antenna engine for unmatched (360°) coverage and capacity enhancements
- Advanced automatic mesh
- Designed for streetlight, wall, or pole deployment
- Client/WDS based CPE connection
- Support for all standard security scheme

Organization of this Document

The GO MBW 1100 Installation Guide for the Wireless LAN Pico Base Station (WLP) offers information and instructions for quickly installing and configuring the MBW 1100 (WLP). The instructions and information are presented in one volume as follows:

<i>Introduction</i>	Contains introductory information about the MBW 1100 (WLP).
<i>GO MBW 1100 (WLP)</i>	Presents a general description and overview of the MBW 1100 (WLP) including content and safety procedures.
<i>Installation Process</i>	Describes the installation process for the MBW 1100 (WLP).
<i>Appendix A</i>	Lists the acronyms that appear in the manual.
<i>Appendix B</i>	Details the wiring specifications.

GO MBW 1100 (WLP)

The GO MBW 1100 (WLP) complements the MBW 2100 (WLS). It delivers street-level coverage and provides capacity enhancements in dense metro areas over a single 802.11b/g channel, while meshing traffic over an 802.11a radio.

The MBW 1100 (WLP) Base Station delivers omni-directional (360°) coverage while retaining full xRF smart antenna engine functionality for enhanced capacity and range.

MBW 1100 (WLP) Package Components

The MBW 1100 (WLP) package items are listed in Table 1:

DESCRIPTION	REV	QTY
Wall/Poll Mount Kit Assembly (new)	1.0	1
Connectors Kit for MBW 1100 (WLP) Package	1.0	1
MBW 1100 (WLP) unit	1.0	1
MBW 1100 (WLP) Access Antenna 2.4GHz 7.4dBi Gain, Omni		4
802.11a 5Ghz 8dBi Omni Mesh Antenna		1
802.11a 5Ghz 8dBi Omni Mesh Antenna (For models MBW 1100F Triple-Radio and MBW 1100E Triple-Radio only)		1
802.11a 4.9Ghz 8.5dBi Omni Mesh Antenna (For model MBW 1100F - HLS (4.9) only)		1
Power Connector with cable length of 6 ft (180cm)		1
Antenna Support Plate		1

Table 1: MBW 1100 (WLP) Package Contents

Deployments of gateway devices connected by wire to an indoor switch/router would include installation of a lightning protector. A lightning protector is not supplied as part of the standard package. It can be ordered from GO Networks as an accessory.

Specific installation may require different Power/Ethernet connections. See [Cable Connections](#) for more details.

MBW 1100 (WLP) Safety Information

RF Exposure

The MBW 1100 (WLP), an outdoor access point, is compliant with the requirements set forth in CFR 47 section 1.1307, addressing RF Exposure from radio frequency devices as defined in OET Bulletin 65. The outdoor access point antennas should be installed to provide a separation distance of at least 3 feet (1 meter) from humans.

MBW 1100 (WLP) Lightning Protector

A lightning protector is required when the MBW 1100 (WLP) unit is installed in an outdoor location and the Ethernet cable connects to an indoor network device.

The purpose of the lightning protection is to protect people and equipment located indoors from lightning that might strike the MBW 1100 (WLP) or its outdoor cables. Therefore, the lightning protector device should be installed indoors, as close as possible to the point where the cables enter the building.

The lightning protector can also be installed outdoors, as long as the cables that go from the lightning protector to the indoors are well protected from lightning between the box and the building entrance.

Verify that you have shared grounding. GO Networks offers a lightning protector that can be ordered separately.

Information de sécurité pour MBW 1100 (WLP)

Exposition aux fréquences RF

Le point d'accès extérieur MBW 1100 (WLP) est compatible avec la norme CFR 47 section 1.1307 concernant l'exposition aux appareils émetteurs de fréquences radio RF définis par le Bulletin 65 de l'OET. Les antennes doivent être installées à une distance minimum d'un mètre de personnes humaines.

Paratonnerre pour MBW 1100 (WLP)

Un paratonnerre est nécessaire lorsque le point d'accès MBW 1100 (WLP) est installé à l'extérieur et lié à un network intérieur par un câble Ethernet.

La fonction du paratonnerre est de protéger les personnes et équipement situés en intérieur des éclairs qui pourraient frapper le MBW 1100 (WLP) ou son câble extérieur. Par conséquent, le paratonnerre doit être installé en intérieur le plus près possible du point où le câble de liaison pénètre le bâtiment.

Le paratonnerre peut aussi être installé en extérieur à la condition que les câbles à l'intérieur du bâtiment soient protégés des éclairs entre le point d'accès et l'entrée du bâtiment

Vérifier que la prise de terre est partagée. GO Networks met à disposition à la vente un paratonnerre.

Installation

Installation Process

Installing the WLAN Pico Base Station involves the following steps:

1. Performing a Site Survey
2. Assembling and Mounting
3. Mounting the MBW 1100 (WLP) unit
4. Connecting the Antennas
5. Connecting the cables
6. Powering up the unit and configuring the software
7. Performing a Post-installation Testing Procedure to verify connectivity and operation

Site Survey

Most wireless LANs include many access points installed in various locations in an overlapping radio-cell pattern. It is important to carefully identify each access point's position and the assignment of its radio channels. Therefore, a site survey becomes an essential first step before physically deploying the MBW 1100 (WLP).

Installation of the access points requires a backhaul to interface the corporate network or Internet. This backhaul connection can be a mesh configuration, an Ethernet-wired connection, or a third-party solution. When using any method other than a wired connection, keep in mind the MBW 1100 (WLP) has to have a good reception on its BH side so it will not limit the access-channel performance.

Conclude the site survey with a detailed plan of the MBW system deployment. The system deployment plan should include MBW 1100 (WLP) mounting points and the routes for the power and backhaul cables.

Note:

Since the mounting structure itself is a potential source of interference, the cell should be mounted with at least 4 feet of clearance between the antennas and the mounting structure.

Assembling and Mounting

The universal mount is used to attach and secure the MBW 1100 (WLP) to a wall, a streetlight arm, or a variety of poles.

The MBW 1100 (WLP) mounting consists of the following stages and should be performed in the following order:

1. Connect the MBW 1100 (WLP) unit to the brackets using the 'L' adaptor.
2. Secure the mounting brackets to a streetlight arm, wall, or pole.
3. Assemble the MBW 1100 (WLP) unit to the bracket.
4. Ground the MBW 1100 (WLP) unit.
5. Align the MBW 1100 (WLP) unit.
6. Mount the Antenna to the MBW 1100 (WLP) unit.

Table 2 lists the universal mount parts:

Item No.	Description	Qty	Picture
A	Wall/Poll Bracket	1	
B	Clamping Bracket	1	
C	MBW 1100 (WLP) 'L' Adapter Wall/Poll Mount	1	
D	Hex Bolt M8x70	2	
E	Hex Bolt M8 x25	1	
F	Flat Washer M8	3	
G	Spring Washer M8	4	

Item No.	Description	Qty	Picture
H	Nut M8	1	
I	Antenna Support Plate	1	

Table 2: Mounting Kit Part List

Hardware and Connectors Installation Tools

The following tools are required to mount the MBW 1100 (WLP) on a pole.

Description	Picture
Combination Wrench (13 mm)	 13 mm

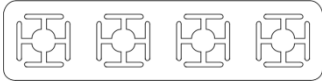
Table 3: Mounting Tools and Equipment

Note: All hardware and tools used for assembling and mounting the MBW 1100 (WLP) are Metric.

To assemble the 'L' adaptor [C] to the MBW 1100 (WLP) unit:

- Attach the 'L' adaptor to the MBW 1100 (WLP) using an M8 x25 hex bolt [E], a spring washer [G], and a flat washer [F], as illustrated in Figure 1.

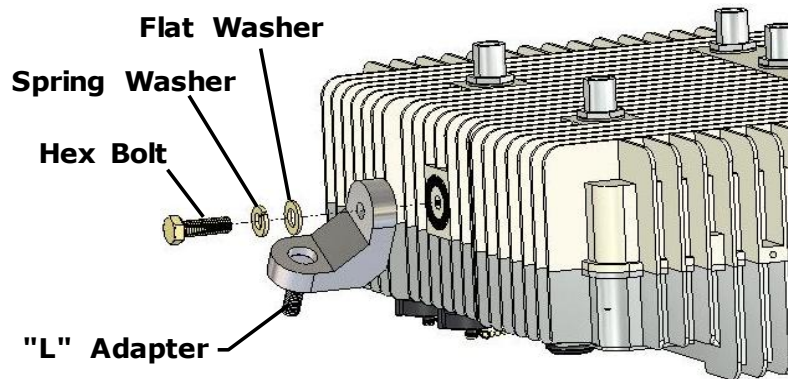

Figure 1: Mount 'L' Assembly

Mounting Brackets

To secure the mounting brackets:

1. Select an optimal mounting location on the pole. Select the highest mounting location with minimal obstacles to the antennas for optimal performance.

NOTE: When mounting the MBW 1100 (WLP), the pole or wall mounting must support a minimum of 61.6 lbs (28 kg). In addition, the pole or wall mounting must support the wind loads from the MBW 1100 (WLP), e.g., 24.2 lbs (11 kg) for wind velocity of 100 mph (160 km/h), 66.1 lbs (30 kg) for wind velocity of 165 mph (264km/h).

Noter: Lorsque vous montez la MBW 1100 (WLP), le poteau ou le montage mural doit supporter d'un minimum de 61.6 lbs (28 kg). En outre, le montage sur le poteau ou sur le mur doit appuyer les surcharges dues au vent de la MBW 1100 (WLP)(par exemple, 24.2 lbs (11 kg) pour la vitesse du vent de 100 mph (160 km/h), 66.1 lb (30 kg) pour l'énergie éolienne Vitesse de 165 mph (264 km/h)).

2. Installation of the mounting brackets to a streetlight arm or a pole differs according to the width of the pole, as illustrated in Figure 2.

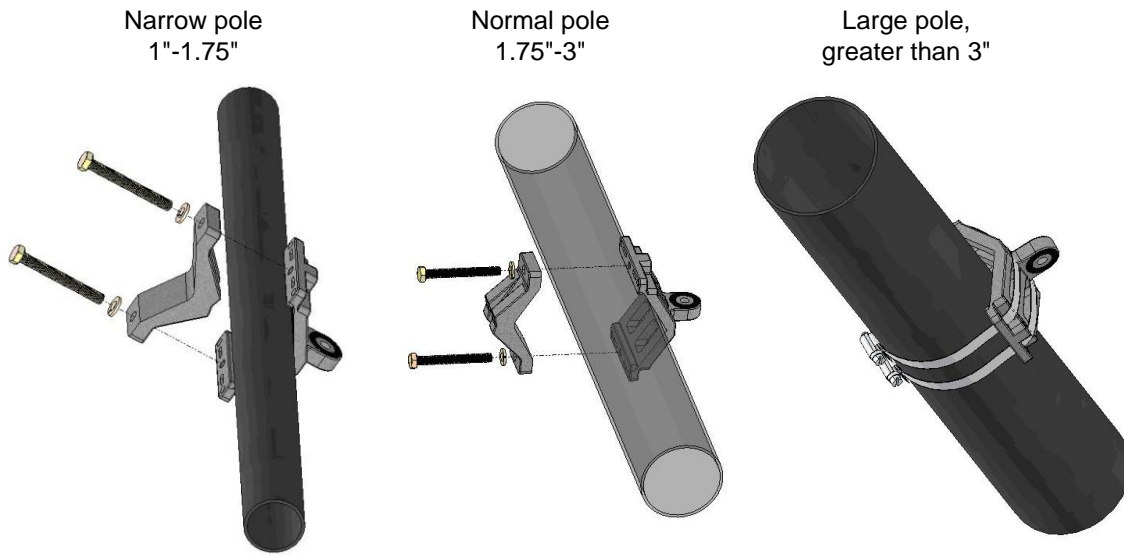

Figure 2: Pole Bracket Assembly

3. For narrow poles (1"–1.75" diameter):
 - a) Place the two brackets, [A] and [B], around the pole at the approximate height where you wish to place the unit. When placing the clamping bracket [B], the small notch side should be in contact with the pole.
 - b) Use two M8x70 hex bolts [D] and spring washers, insert them through both brackets and tighten them around the pole so that the two brackets are securely fastened.
4. For normal poles (1.75"–3" diameter):
 - a) Place the two brackets, [A] and [B], around the pole at the approximate height where you wish to place the unit. When placing the clamping bracket [B], the large notch side should be in contact with the pole.
 - b) Use two M8x70 hex bolts [D] and spring washers [G], insert them through both brackets and tighten them around the pole so that the two brackets are securely fastened.
5. For poles larger than 3" in diameter:
 - a) The wall/pole bracket [A] and two 0.5" (13mm) wide stainless steel hose clamps (not supplied with mounting kit) are used. The hose clamps must be the appropriate size to fit around the pole and bracket.
 - b) Open the each hose clamp by rotating the screw on the clamp counterclockwise. There may be additional resistance just before the clamp is completely open. This is normal and you should continue rotating the screws until the clamps are open.

- c) Insert the band of each clamp through both slots and over the bracket [A].
 - d) Place the bracket [A] and hose clamps around the pole at the approximate height where you wish to place the unit.
 - e) Close each clamp by reinserting the band under the screw and rotate the screw clockwise.
 - f) Position the bracket in the appropriate location and tighten the clamps around the pole so that the bracket is securely fastened.
6. For wall mounting:
- a) Fasten the wall/pole bracket [A] to the wall using four 3/16" (5mm) bolts, as shown in Figure 3. Use the appropriate bolts and fasteners, which is dependent on the material of the wall. Wall-mounting bolts and fasteners are not supplied with the mounting kit.
 - b) Place the wall/pole bracket [A] at the appropriate location where you wish to place the unit. Using the four holes at the corners of the bracket, mark the location where the fasteners need to be installed.
 - c) Install the four fasteners in the wall.
 - d) Insert the four bolts through the bracket and securely fasten the bracket to the wall.

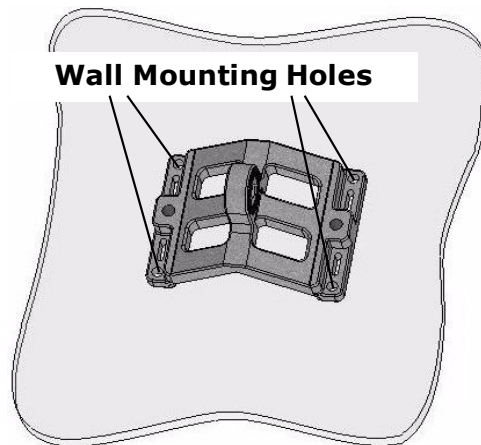

Figure 3: Bracket Wall Mounting

Mounting the MBW 1100 (WLP)

To mount the MBW 1100 (WLP) unit:

1. After assembling the brackets, mount the MBW 1100 (WLP) unit on to the bracket as shown in Figure 4. Use a flat washer [F], a spring washer [G] and a nut [H].

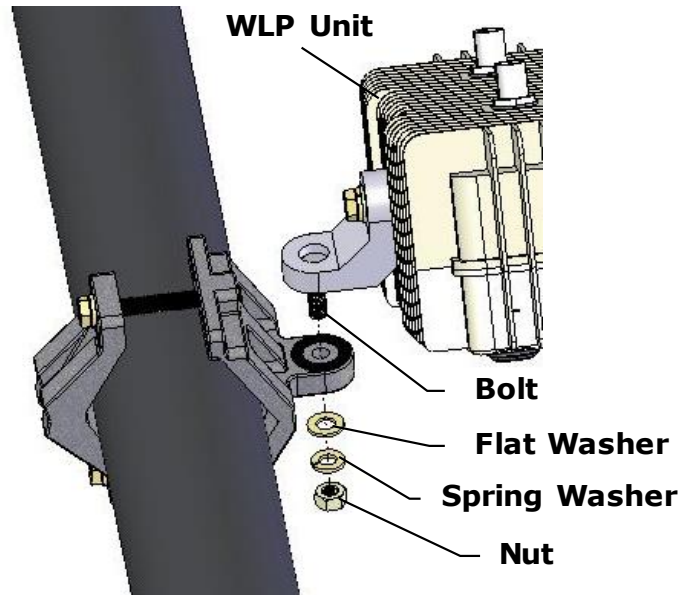

Figure 4: MBW 1100 (WLP) Unit Mounting

2. Once the MBW 1100 (WLP) unit is mounted, release the bolts slightly and align the MBW 1100 (WLP) unit horizontally using the level, as shown in Figure 5. When the unit is perfectly aligned, firmly close all bolts, applying 120 inch-lbs of torque.

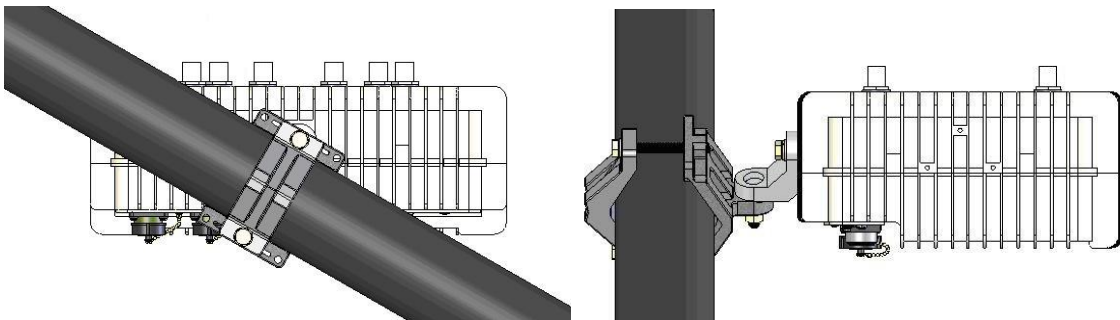

Figure 5: Aligning the MBW 1100 (WLP)

Mounting the Antennas

The MBW 1100 (WLP) supports six antennas. Four WiFi antennas used for user access, which operate on the 2.4 GHz band, marked A1 to A4. Two antennas are used for the mesh networking connections, marked B2 and B3.

To mount the antennas on the MBW 1100 (WLP):

1. Attached the four 2.4 GHz band antennas to terminals A1 to A4 and screw all antennas into place by hand. Rotate each antenna at its metallic base. The antennas should rotate easily. Tighten the antenna by hand only. Do not apply excessive force by using any tool, as this may damage the unit.

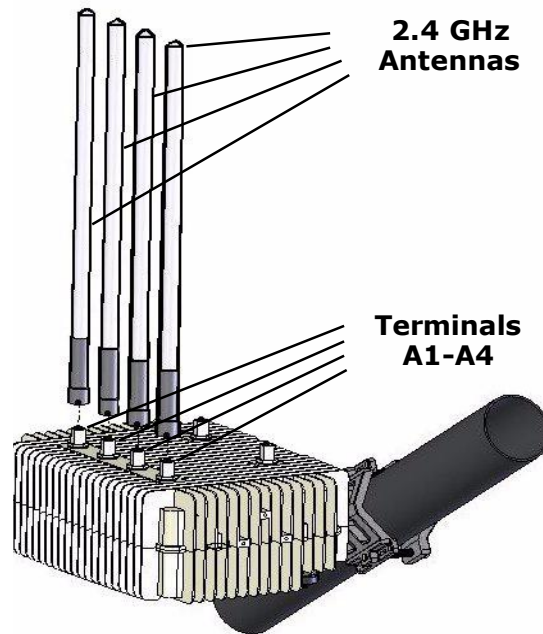

Figure 6: 2.4 GHz Band Antennas Installation

2. Insert the four 2.4 GHz band antennas into the Antenna Support Plate. The antennas must be inserted evenly, so that the plate is level and all the antennas are protruding the same. Use caution not to change the alignment of the MBW 1100 (WLP).

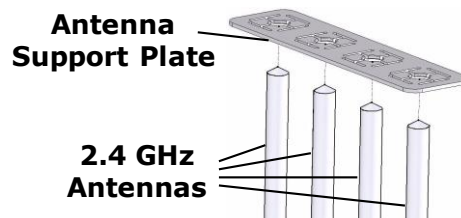

Figure 7: Antenna Support Plate Installation

3. Attach a 5 GHz band antenna to terminal B2. Tighten the antenna by hand at its metallic base. The antenna should rotate easily. Do not apply excessive force by using any tool, as this may damage the unit.

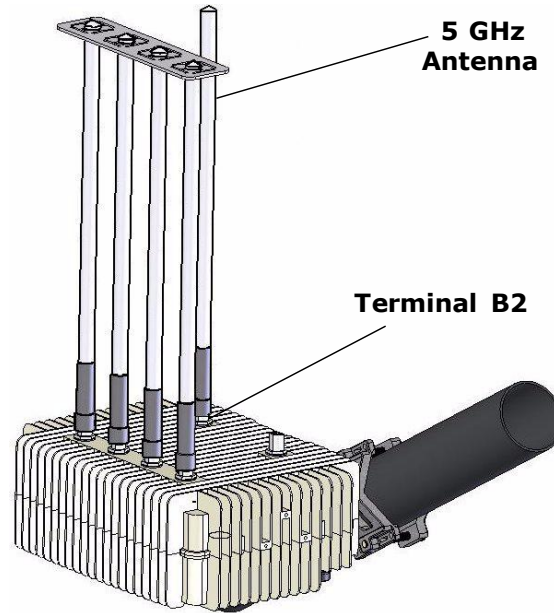

Figure 8: 5 GHz Band Antenna Installation

4. For models MBW 1100F Triple-Radio, MBW 1100F 58, MBW 1100F-HLS and MBW 1100E Triple-Radio; attach the 5GHz or 4.9GHz third band antenna to terminal B3. Tighten the antenna by hand at its metallic base. The antenna should rotate easily. Do not apply excessive force by using any tool, as this may damage the unit.

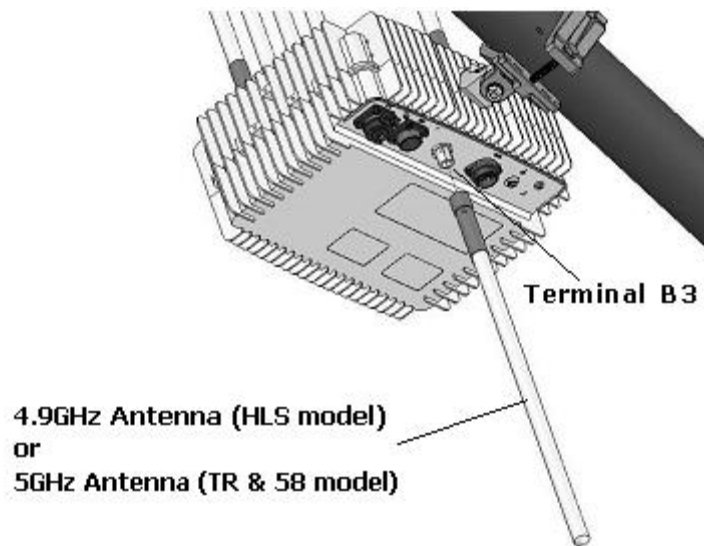

Figure 9: 5 GHz or 4.9GHz Third Band Antenna Installation

5. One or both of the 5GHz antennas can be replaced by a panel antenna (e.g. MBW-WLS-ANT-KT-5820) for point to point connections which require better link budget.

Cable Connections

When the MBW 1100 (WLP) is properly aligned, the connectors are located at the bottom of the unit.

Cable requirements are often unique to the location and deployment topology of each installation. As a result of this limitation, the Ethernet and grounding cables are not included in the installation kit.

The following cables are required to install the MBW 1100 (WLP) unit and should be connected in the following order:

- **Grounding Cable** – Provides the necessary electrical safety functions.
- **Ethernet Cable** – Required only for MBW 1100 (WLP) units connected to a wired network.
- **Power Cable** – Supplies AC power to the MBW 1100 (WLP) unit.
- **RS-232 Console Cable** – Provides a connection from the MBW 1100 (WLP) unit to a console (laptop computer) for configuration. This is only required when the MBW 1100 (WLP) unit is not pre-configured. This cable is not provided with the MBW 1100 (WLP) unit. It is recommended that the MBW 1100 (WLP) is pre-configured prior to installation.

Table 4 lists the MBW 1100 (WLP) Connectors Kit parts:

Item No.	Description	Qty	Picture
A	Solderless Ring Terminal	1	
B	Sealed RJ45 connector	1	
C	Power Connector	1	

Table 4: Mounting Kit Part List

Cable Installation Tools

The following special tools are required to install and connect cables related to the MBW 1100 (WLP).

Description	Picture
Slotted Screwdriver 1/8" (3mm) wide	
RJ45 Crimp Tool	 HT-210A

Table 5: Cable Installation Tools and Equipment

Grounding Cable

Connect a grounding wire to the grounding screw at the bottom of the MBW 1100 (WLP) unit. A 10 AWG grounding cable is required to ground the MBW 1100 (WLP) unit.

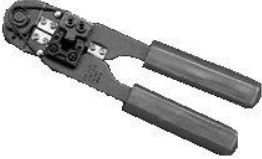
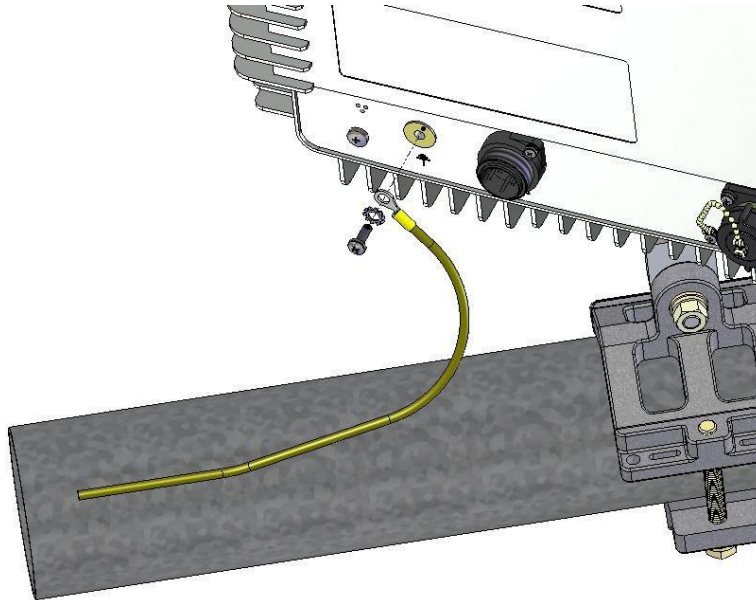

Figure 10: Grounding Connection

To ground the MBW 1100 (WLP) unit:

1. Crimp the solderless ring terminal [A] contained in the MBW 1100 (WLP) Connectors Kit to the grounding cable.
2. Attach the solderless ring terminal [A] to the bottom of the MBW 1100 (WLP) unit using the grounding screw.
3. Connect the other end of the grounding cable to a proper ground.

Note: Connect the 10 AWG grounding cable before connecting any other cables. When removing the MBW 1100 (WLP), the grounding cable should be the last cable removed.

Noter: *Connecter la prise de terre 10 AWG avant de connecter tout autre câble. Pendant la désinstallation du MBW 1100 (WLP), la prise de terre doit être le dernier câble retiré.*

Ethernet Connection

Ethernet connection is used for wired backhaul connection or an interface to a third party wireless BH solution. Use outdoor rated CAT5 shielded cables or better. The outer diameter of the Ethernet cable should be 4.8 – 7 mm. When using CAT5 shielded cables the cable can be up to 100 meters.

Following is a diagram explaining how the Ethernet cable should be assembled prior to connecting it to the MBW 1100 (WLP) unit:



Figure 11: Ethernet Cable Connector

Power Connection

The MBW 1100 (WLP) unit can be connected to an AC power source by one of several methods. It can be connected directly to a power source or by using an optional adapter to connect to the streetlight photocell (photo-control). The MBW 1100 (WLP) unit can support input voltage of 100 to 240 VAC (50 to 60 Hz).

Note: Connect the grounding cable before connecting any other cables. When removing the MBW 1100 (WLP), the grounding cable should be the last cable removed.

Noter: *Connecter la prise de terre 10 AWG avant de connecter tout autre câble. Pendant la désinstallation du MBW 1100 (WLP), la prise de terre doit être le dernier câble retiré.*

To connect the AC power to the MBW 1100 (WLP) via the streetlight photocell:

1. Check the input voltage to the streetlight photocell. The voltage must be between 100 to 240 VAC. If yes, continue with this procedure. Otherwise, use a different method for the power connection.
2. Remove the streetlight photocell. Turn the photocell counterclockwise and lift the photocell out of the socket.

3. Insert the Auxiliary Power Adapter in the socket of the photocell. Note that one prong is larger than the other two. Align the larger prong on the adapter with the larger slot in the socket. Insert the Auxiliary Power Adapter into the socket and rotate the adapter clockwise.
4. Insert the photocell into the Auxiliary Power Adapter. Align the larger prong on the photocell with the larger slot in the socket on top of the adapter. Insert the photocell into the socket and rotate the photocell clockwise.
5. Connect the Auxiliary Power Adapter cable to the power connector socket on the MBW 1100 (WLP).
6. After connecting the power, verify that the Power (PWR) LED is lit.
7. Check the photocell. Cover the photocell and verify that the streetlight operates.

Console Connection

Figure 12 illustrates the RS-232 cable connections used to connect the MBW 1100 (WLP) to a console (notebook computer to configure the MBW 1100 (WLP)). For more information regarding the serial cable, see *Appendix B: Wiring Specifications*.

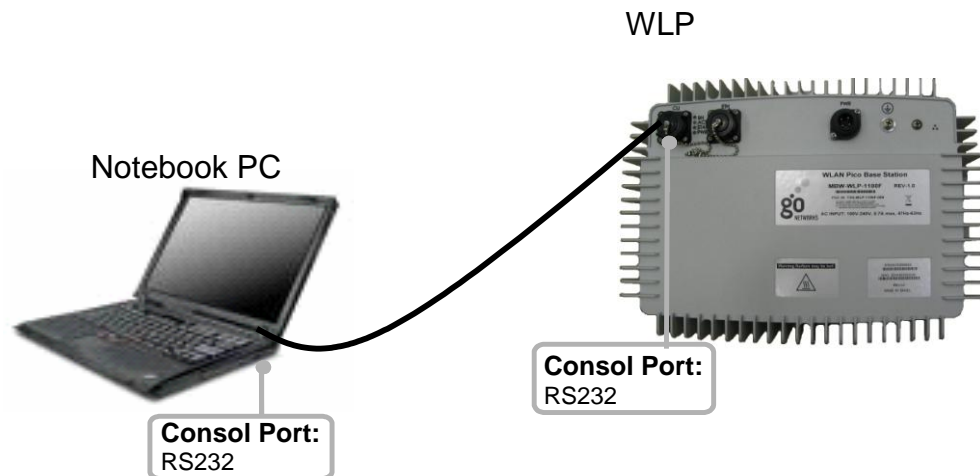

Figure 12: Connect and Access the MBW 1100 (WLP)

Note: New laptops may not include an RS-232 serial port. If a serial port is not available, you may use a USB to serial converter.

Power Up and Software Configuration

The MBW 1100 (WLP) unit is normally mounted on a streetlight (pole or wall) where it is inconvenient to configure. Therefore, it is recommended that wireless communication be established to the unit prior to installation, so that the unit can later be configured and monitored from the ground. To verify communications when installing the MBW 1100 (WLP) unit, the Mesh-Gateways must be installed and powered up first.

The LEDs on the MBW 1100 (WLP) unit indicate the status of communications between the MBW 1100 (WLP) unit and the network. See Table 6 for more information on the LED indicators.

The ACT LED on the Mesh-Gateway should be checked to verify that wired communications have been established. The BH LED on the Mesh-Gateway should be checked to verify that wireless communications have been established.

When powering up a Mesh-Node, the BH LED should be lit to verify that the MBW 1100 (WLP) unit's wireless communication is connected. MBW 1100 (WLP) boot time is about 2.5 minutes. The BH LED indicator will light up after the boot is completed.

LED	Function
PWR	Green – There is power to the unit. Unlit – There is no power to the unit.
STAT	Green – The operational status of the MBW 1100 (WLP) unit is normal. Red – The MBW 1100 (WLP) unit is in a failure state. Unlit – There is no power to the unit.
ACT	Green – When the LED is on, there is a communication connection. When the LED is flashing, traffic is flowing through the MBW 1100 (WLP) unit. Unlit – There is no communication connection.
BH	Green – On a Mesh-Gateway, the mesh functionality is activated. On a Mesh-Node, the MBW 1100 (WLP) is connected to the mesh. Unlit – On a Mesh-Gateway, the mesh functionality is not activated or no Ethernet link is available. On a Mesh-Node, the MBW 1100 (WLP) is not configured or failed to connect to the mesh.

Table 6: MBW 1100 (WLP) LED Indicators

Appendix A: List of Acronyms

Acronym	Explanation
802.11	A family of specifications related to wireless networking, including: 802.11a, 802.11b, and 802.11g.
AP	Access Point. The hub of a wireless network. Wireless clients connect to the access point, and traffic between two clients must travel through the access point. Access points are often abbreviated to AP
BSSID	Broadcast Service Set Identifier
CPE	Customer Premises Equipment.
DHCP	Dynamic Host Configuration Protocol. A protocol which enables a server to automatically assign an IP address to clients so that the clients do not have to configure the IP addresses manually.
EAP	Extensible Authentication Protocol. A standard form of generic messaging used in 802.1X.
ESSID	Extended Service Set Identifier
PMK	Pairwise Master Key
SSID	Service Set Identifier, a set of characters that give a unique name to a WLAN.
TKIP	Temporal Key Integrity Protocol
VLAN	Virtual Local Access Network
WDS	Wireless Distribution System
WEP	Wired Equivalent Privacy. An encryption system created to prevent eavesdropping on wireless network traffic.

Acronym	Explanation
WLP	Wireless Base Station. Access point of the GO Networks MBW solution. (MBW 1100)
WLS	Wireless Base Station access point of the GO Networks MBW solution. (MBW 2100)
WMG	Wireless Media Gateway of the GO Networks MBW solution. GO Media dedicated CPE.
WNC	Wireless Network Controller of the GO Networks MBW solution.
WPA	WiFi Protected Access. A modern encryption system created to prevent eavesdropping on wireless network traffic. It is considered more secure than WEP.
WPA-EAP	WPA-Extensible Authentication Protocol
WPA-PSK	WPA-Pre-shared key

Appendix B: Wiring Specifications

Console Port (DTE)	RJ-45-to-RJ-45 Straight Cable		RJ-45 to DB-9 Terminal Adapter	Console Device
Signal	RJ-45 Pin	RJ-45 Pin	DB-9 Pin	Signal
No connection	1	1	8	CTS
No connection	2	2	6	DSR
No connection	3	3	5	GND
GND	4	4	5	GND
RxD	5	5	3	TxD
TxD	6	6	2	RxD
No connection	7	7	4	DTR
No connection	8	8	7	RTS

Table 7: Console Port Signaling and Cabling with a DB-9 Adapter for the MBW 1100 (WLP) Unit