

## MAINTENANCE AFTER FLYING

- (A) Unplug the rechargeable battery from the battery compartment of the plane after landing.
- (B) Switch off the power of the transmitter.
- (C) Check if the propeller is damaged or not. If yes, replace it with a new one. (1 extra propeller is provided)
- (D) Check the fuselage, wings, vertical fin and horizontal stabilizer if there is any damage.
- (E) Use a soft and clean cloth to clean the airplane after flying.
- (F) If the wings, horizontal stabilizer and / or vertical fin is damaged slightly, use a transparent tape to repair. (Fig.32)

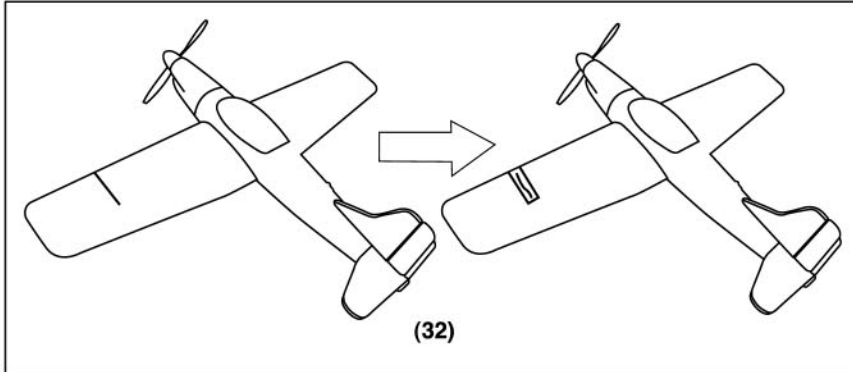

### WARNING:

1. Please do not re-charge the rechargeable battery continuously twice or more.
2. Please ensure that the re-chargeable battery is fully out of power (when the plane cannot fly) before re-charging it.
3. If the red light indicator keeps blinking, it means the power of the "D" size batteries or the electric power from the car is running low. You need to change the "D" size batteries or re-start your car engine.
4. This charger is designed for the rechargeable battery of this product. Do not re-charge other kinds of batteries with this charger.
5. The charger has a built-in "2A" fuse. When short-circuit happens, the fuse will burn off and cut off the power for protection and safety purpose.
6. If smoke comes out from the battery charger or if any abnormal situation happens during charging, please immediately cut off the power by switching to the "OFF" position and unplug the charger from the power source. Stop charging the rechargeable battery or using the charger.

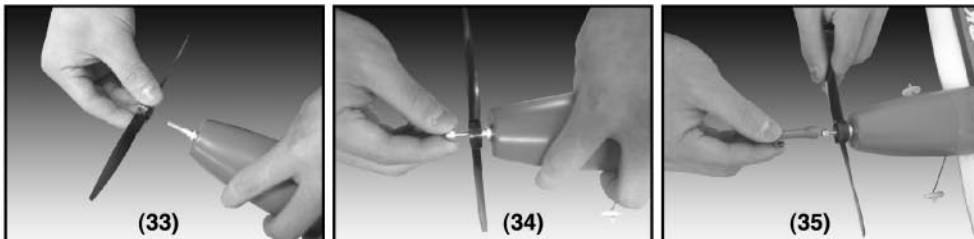

#### FCC NOTE:

THE ANTENNA PROVIDED IS A UNIQUE ANTENNA. BY INSTALLATION OF UNAUTHORIZED ANTENNA TO THIS EQUIPMENT. SUCH UNAUTHORIZED INSTALLATION COULD VOID THE USER'S AUTHORITY TO OPERATE THE EQUIPMENT.

THE MANUFACTURER IS NOT RESPONSIBLE FOR ANY RADIO OR TV INTERFERENCE CAUSED BY UNAUTHORIZED MODIFICATIONS TO THIS EQUIPMENT. SUCH MODIFICATIONS COULD VOID THE USER'S AUTHORITY TO OPERATE THE EQUIPMENT.

IF YOU FIND ANY FUNCTIONAL PROBLEMS IN OPERATING THIS TOY, PLEASE READ CAREFULLY THE INSTRUCTION SHEETS AND/OR E-MAIL US AT THE FOLLOWING ADDRESS:

[info@golden-bright.com](mailto:info@golden-bright.com)

# Tech.art®

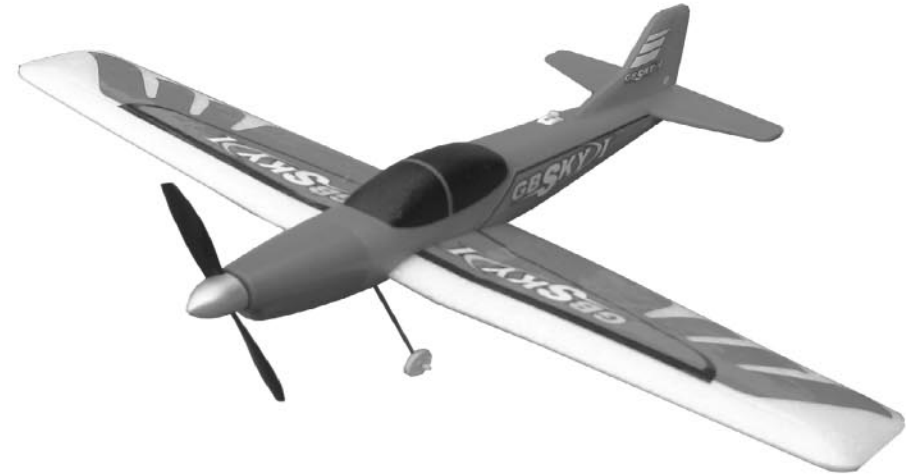

# GBSKY I

## IMPORTANT NOTES

1. Check the contents list and all parts.
2. Study the instruction manual carefully before assembling.
3. Ensure all required batteries are ready.
4. Follow the instructions printed in manual when using the quick charger
5. This product is intended for 14 years old and up. (Adult supervision is required if user is below 14 years old)
6. Do not fly over or near people, power pylon, buildings, highways, train rails, vehicles, trees, lake, and airport.
7. Do not fly if wind speed is over 3 M/S(or over 5 mph)

ITEM NO. 9803

# CONTENTS

(A). Check the contents list and parts (Fig.1):

- |                               |                           |
|-------------------------------|---------------------------|
| ① 1 Main Wing                 | ⑨ 1 Landing wheel         |
| ② 1 Nut                       | ⑩ 1 Antenna               |
| ③ 1 Wheel Wrench              | ⑪ 1 Wind ribbon           |
| ④ 1 Fuselage                  | ⑫ 1 Quick charger         |
| ⑤ 1 Propeller (spare)         | ⑬ 1 Plastic sheet         |
| ⑥ 1 Rechargeable battery pack | ⑭ 1 Transmitter           |
| ⑦ 9 Screws                    | ⑮ 1 "DC" connector to car |
| ⑧ 1 Screwdriver               | ⑯ 1 Main Wing stabler     |

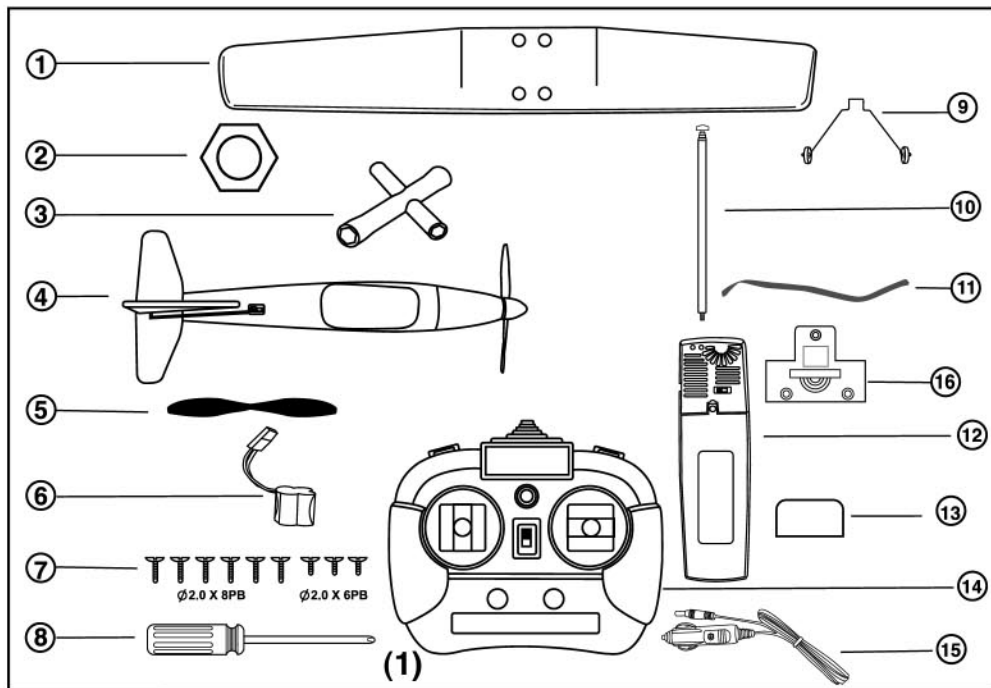

## BATTERIES REQUIREMENT

- 9V alkaline battery (not included) for transmitter.(Fig.2)
- 6 x "D" alkaline batteries (not included) for portable quick charger.(Fig.3)
- Ni-Mh 23AAA 220mAh P 4.8V rechargeable battery pack (included).(Fig.4)

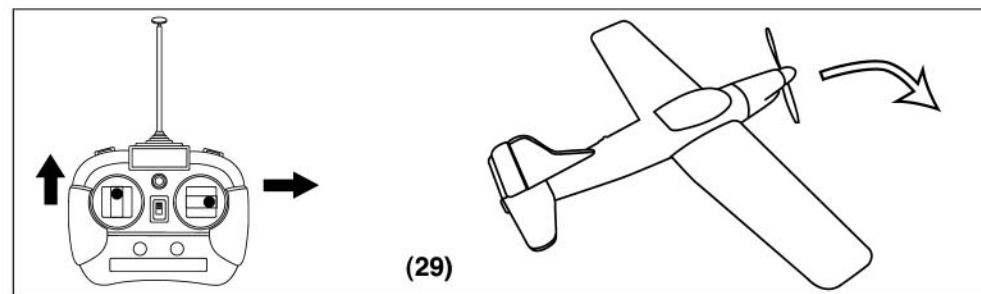
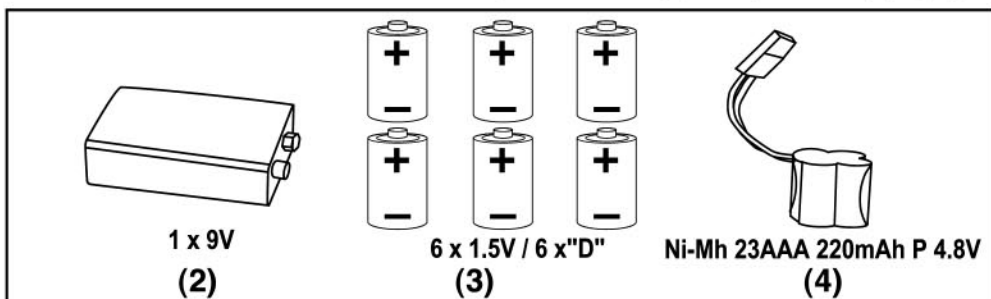

**4. Right steering**  
Switch the right stick on the controller to the right and then let it back to the center. Repeat this action until the airplane fully turns. (Remarks:The left stick should be pulled to the top) (Fig.29)

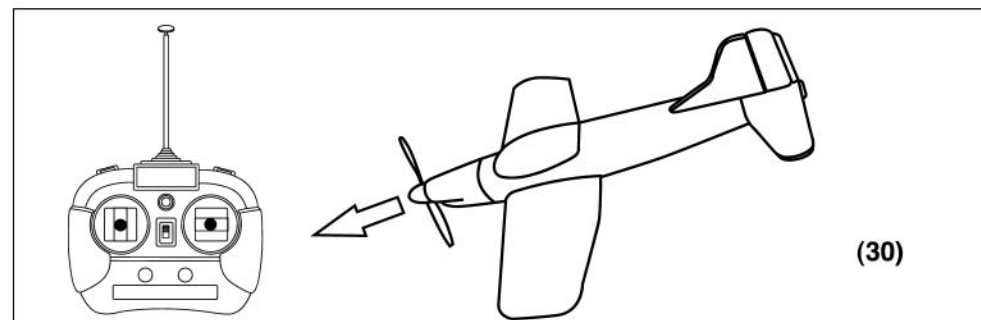

**5. Descending**  
Keep the left and the right sticks on the controller at the center and let propellers stop rotating. The airplane will descend. (Fig.30)

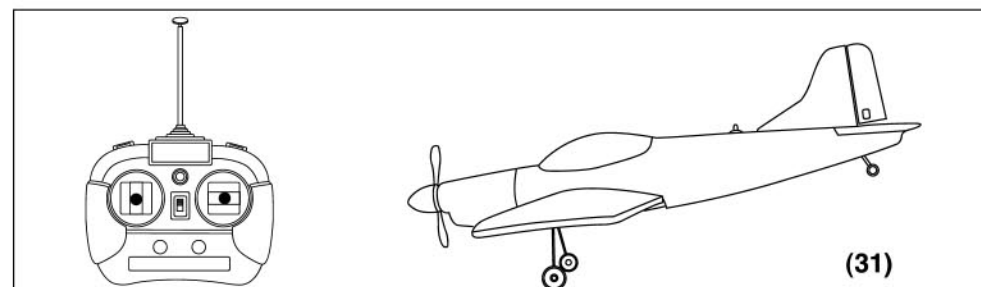

**6. Landing**  
Before landing, let the airplane cruises by stop pulling the left stick on the controller and propellers stop rotating. Adjust the left and right turning lever for the desired landing spot. The airplane must fly directly head to the wind when landing. Normal flying time (including cruise): approximately 8 minutes. (Fig.31)

**Flying Distance**  
Pay attention to the flying distance. The control range should not exceed 200 m / 656 feet. If you fly over this limit, airplane will automatically cut the power source and descend.

## LABELING INSTRUCTION

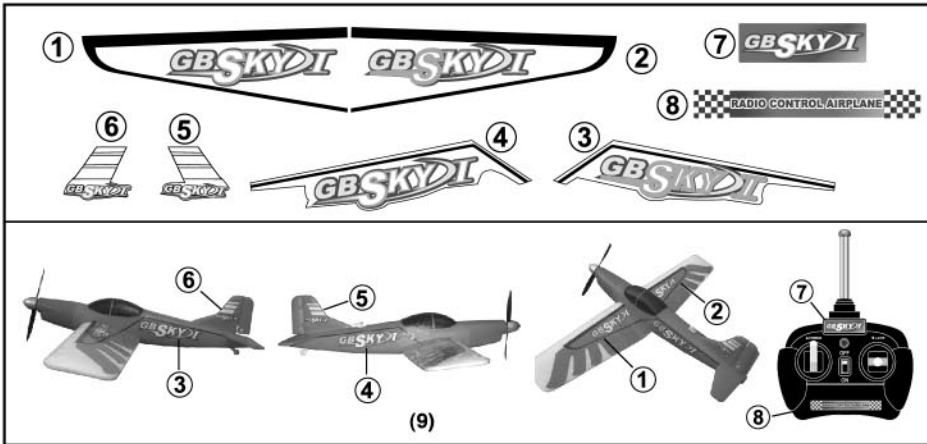

## ASSEMBLY INSTRUCTIONS



10. Put on Main Wing stabler



12. Put the main wing on the fuselage as shown.(Fig.12)

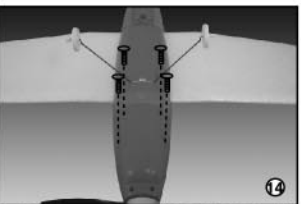

14. Use four screws  $\phi 2.0 \times 8PB$  to fix the main wing as shown.(Fig.14)

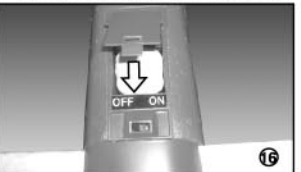

14. Close the hatch cover as shown.(Fig.16)



11. Installed by Screw  $\phi 2.0 \times 6PB$

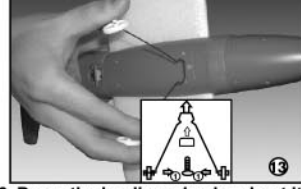

13. Press the landing wheel and put it into the slot of the fuselage as shown(Fig.13) then insert the plastic sheet into the slot and lock it by  $\phi 2.0 \times 8PB$ .

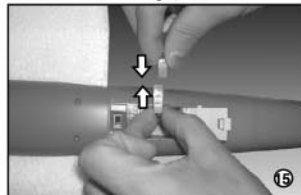

15. Open the hatch cover and plug in the fully charged rechargeable battery inside the plane.(Fig.15)



15. Lock the hatch cover.(Fig.17)

3

## TEST THE WIND SPEED



Tie the included wind ribbon to the end of transmitter antenna (Fig.18).

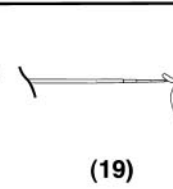

Extend the antenna, hold the transmitter flat so the antenna is parallel to the ground and see the ribbon moves in the wind (Fig.19).

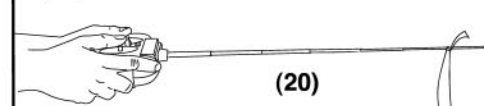

If the ribbon hangs down, the wind speed is good for flying (Fig.20)

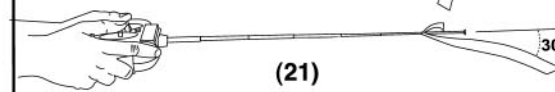

If the angle between the antenna and the flag is less than  $30^\circ$ , it is too windy for flying (Fig.21).

## RANGE TEST

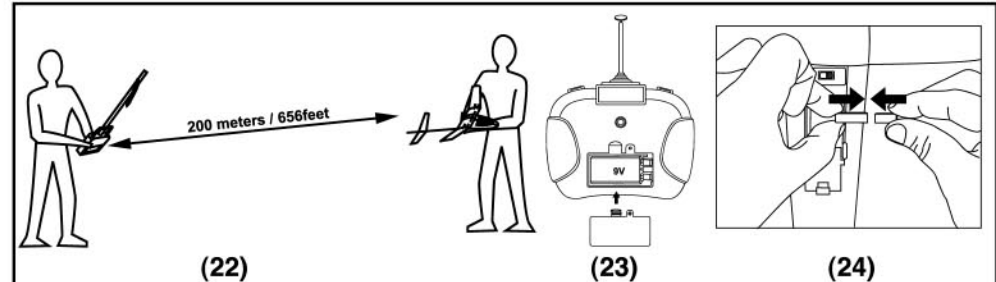

You need two people to do the range test - one to hold the transmitter and one to hold the airplane.(Fig.22) Distance between two people should be around 200 meters / 656 feet to test all functions of the airplane.

Install 1x9V alkaline battery into the transmitter, extend the antenna and turn on the transmitter.(Fig.23)

Plug in the Ni-Mh 23AAA 220mAh P 4.8V rechargeable battery and close the hatch cover.(Fig.24)

## CAUTIONS!

The person who holds the airplane should NOT touch the propeller with any part of his body to avoid injury. (Fig.25)

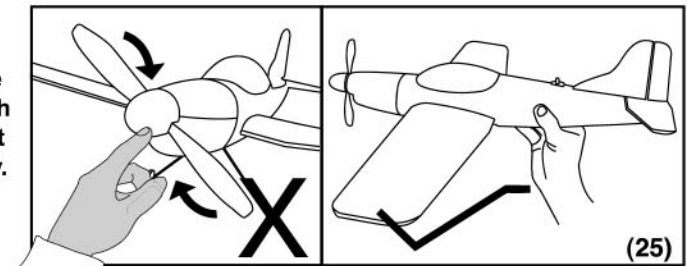

4

## SELECT A FIELD

A large open grass field with soft ground is the best. Make sure NO interference from other instruments in your vicinity with the same frequency.

## LET'S GO FLYING

### 1. Starting

#### a). Fly by hand.

Use left hand to hold the transmitter and switch it "ON", right hand hold the airplane. Left hand pull the left stick on the controller to the top and the propeller rotates in high speed, throw out the airplane horizontally and directly head to the wind, and watch the airplane flying position. (Fig.26a)

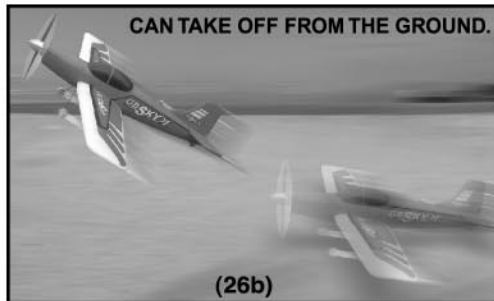
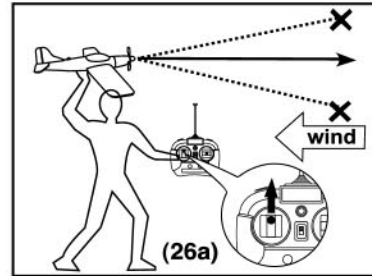

#### b). Take off from the ground.

Place the airplane on the ground and switch "ON" the transmitter. Pull the left stick to the top on the transmitter and propellers will rotate in full power. The airplane will move forward in full speed and take off from the ground. (Fig.26b)

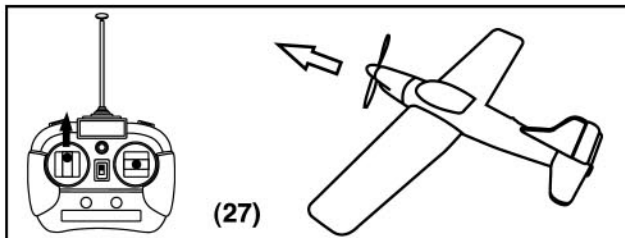

### 2. Climbing

Apply full power by pulling the left stick on the controller to the top and the airplane keeps on climbing. Do not try to turn around until the plane reaches a height of 20 meters / 60 feet from the ground. (Fig.27)

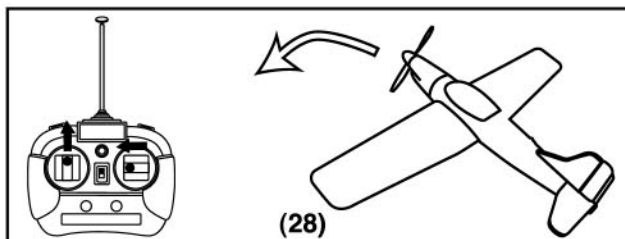

### 3. Left steering

Switch the right stick on the controller to the left and then let it back to the center. Repeat this action until the airplane fully turns. (Remarks: The left stick should be pulled to the top ) (Fig.28)

## TECHNIQUES

Heading directly to the wind when climbing and landing. Use "PUSH" and "RELEASE" method to the control lever when turning left and right. Plane will be lost control if the left / right lever is pushed for a long time continuously. If it is windy when climbing, it is suggested to turn the plane slightly but still heading into the wind. When landing, the plane should be headed directly to the wind.

#### Special Attention:

Never try to catch the plane whenever the plane is in motion to avoid personal injury.

5

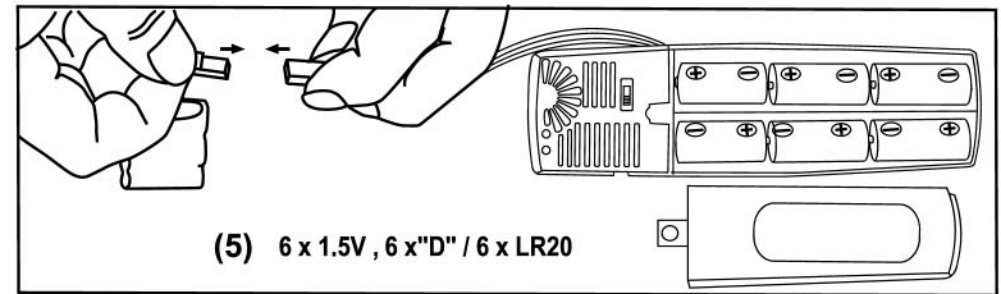

1) Plug the 4.8V 23AAA rechargeable battery to the connecting plug of the portable charger.

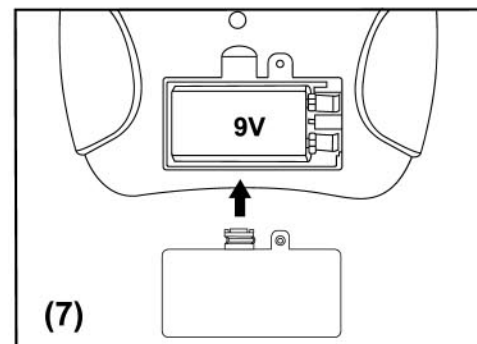
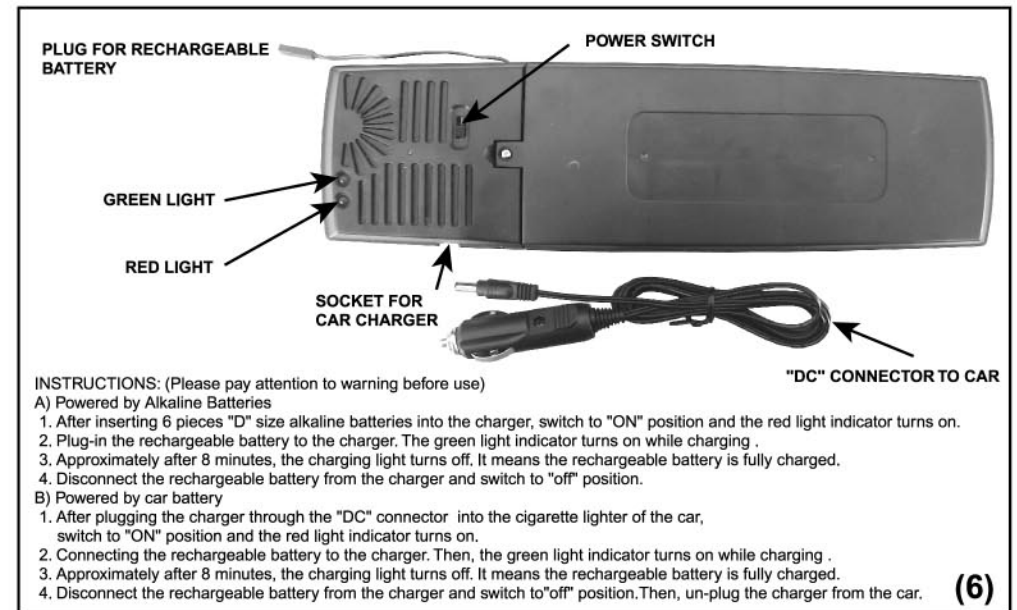

(7)

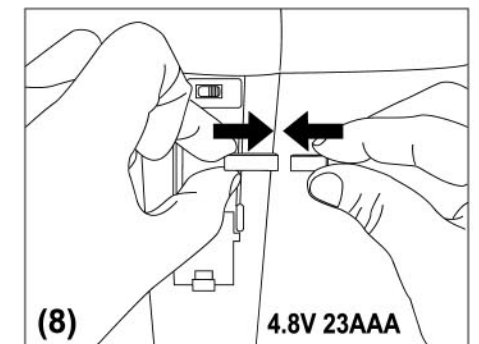

(8)

4.8V 23AAA

2