



This product speaks with other Z-Wave certified devices

Wireless Appliance Control Module

PA-100

Plug In Appliance Module

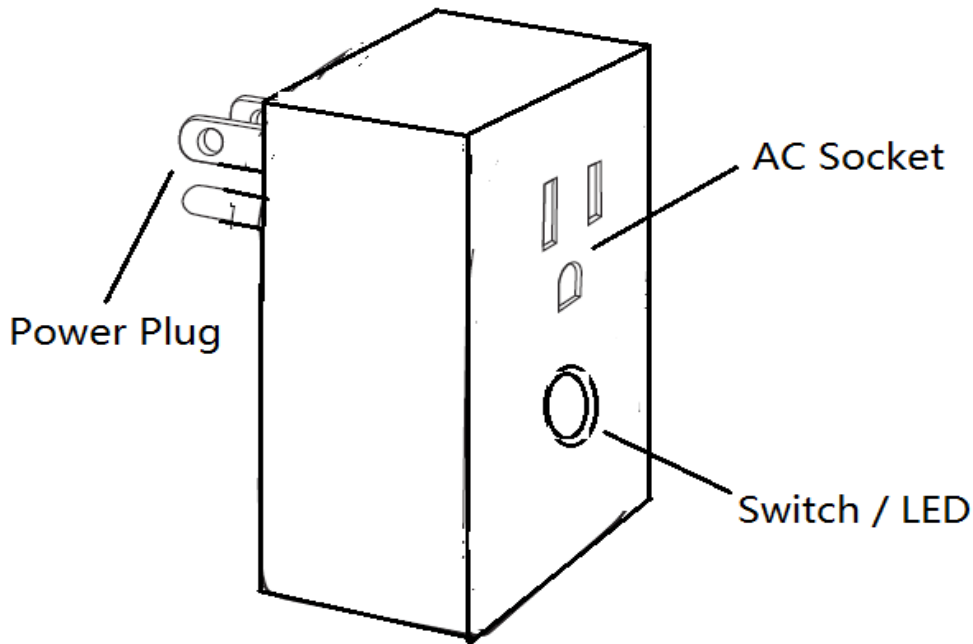

## INTRODUCTION

domitech™ PA-100 is a member of the Z-Wave® family and communicates with other Z-Wave certified devices in a control network. PA-100 can be used to turn On or Off lamps or AC operated appliances. PA-100 device serves as a node to repeat the signal in the network, thus, extending the overall Z-Wave mesh wireless network range. Different types and brands of Z-Wave devices can be associated with domitech PA-100 in your system and they will work together to optimize and expand the coverage of your Z-Wave network. Once setup is completed, you can enjoy the convenience and leisure which PA-100 offers.

## FEATURES

- Works with incandescent, florescent (CFL) or LED lighting and AC operated appliance
- ON/OFF status and location LED indicator
- Can be controlled wirelessly or manually
- Tamper resistant screws
- GROUP/SCENE/ALL enabled
- Plug and play, simple setup
- Lightweight and compact. Does not block the second AC outlet.
- Grounded 3-pin AC power receptacle and plug to enhance safety
- Over-The-Air firmware upgrade available with compatible gateway, Z-Wave static controller, PC and software
- Powered by Z-Wave 500 Series module inside
- Internal resettable fuse to protect from surge current
- Manual reset capability

**! WARNING !**

**RISK OF FIRE, ELECTRICAL SHOCK & BURNS**

**DO NOT USE WITH MEDICAL AND LIFE SUPPORT INSTRUMENT**

No user serviceable parts are in this module

To minimize the risk of electric shock, the power plug of this module has a grounding pin which only fits into a grounding 3-prong electrical outlet. Please call a qualified electrician to replace the outlet if the plug does not fit into it. Do not attempt to change the plug in any way.

The appliance connected to this Z-Wave module must not exceed 900W incandescent, 200W CFL/LED, ½ horsepower motor and 15A, 1800W resistive load.

## SETUP

Step 1. Plug in the AC power plug of the appliance to the receptacle of PA-100

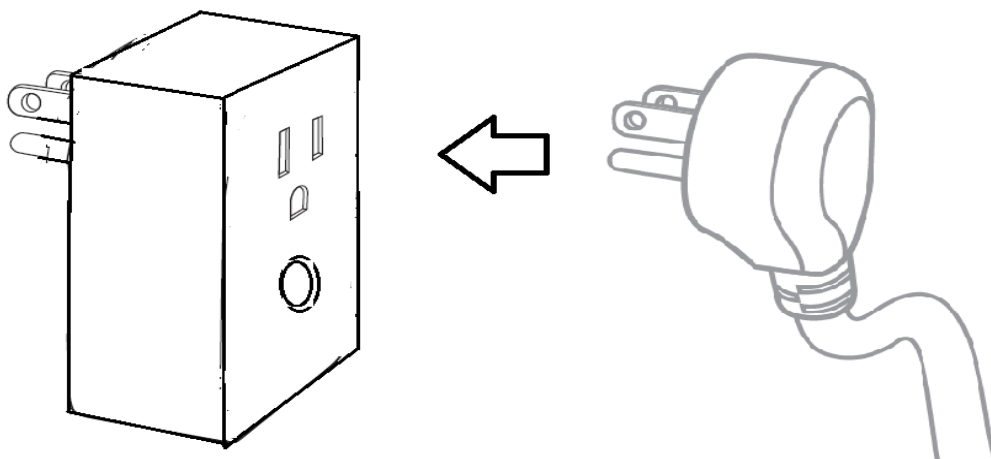

Step 2. Insert the PA-100's 3-pin plug into an AC outlet of your preferred location. In normal operating mode, the LED on the front panel will be lit.

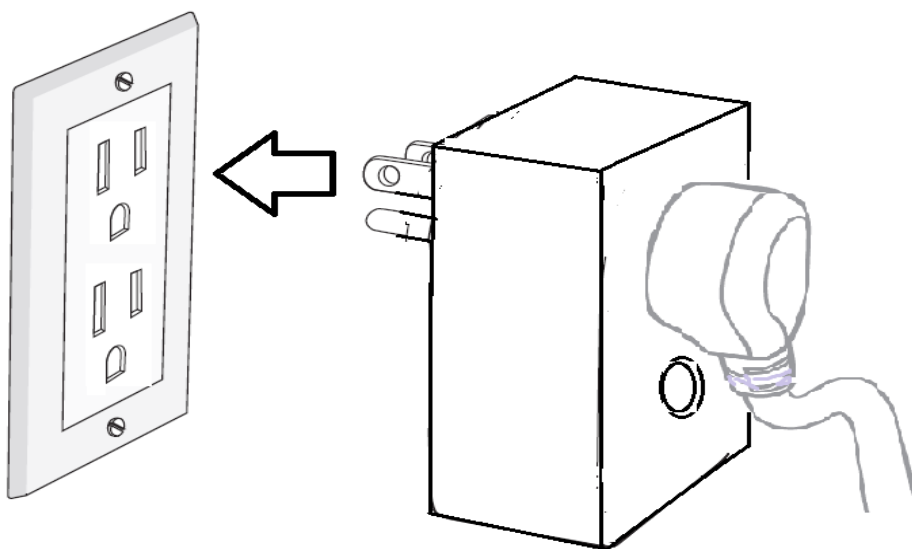

Step 3. Add (Include) the module into your network by a Z-Wave certified controller. Please refer to your gateway or controller's instructions manual for details. Normally, the sequence is as follows:

1. Initiate software to add a new device on your controlling device
2. When the controller's software is ready, single click the button on the front of PA-

3. The controller's software should indicate that the new device was added successfully.

If the controller's software shows it was a fail, repeat the procedure.

Note: If Inclusion still fails after the 2<sup>nd</sup> attempt, you need to first reset the PA-100 before repeating the above step. The manual reset method is as follows,

- a. Unplug PA-100 from the AC outlet and also unplug the power plug of the appliance from the module (if plugged in)

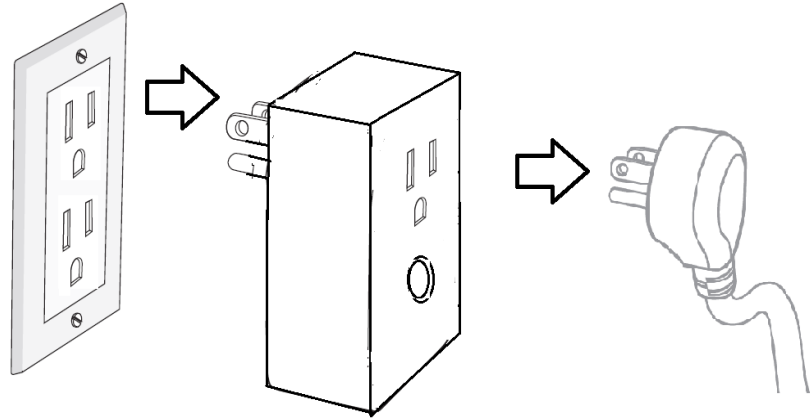

- b. Press and hold the button on the module

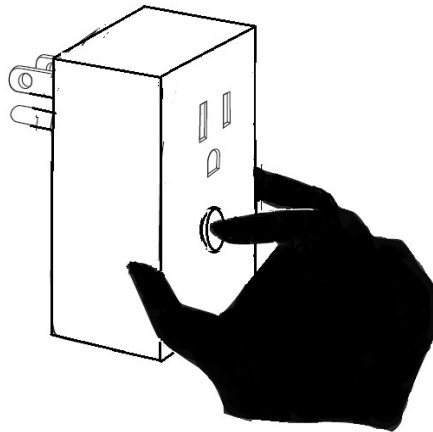

- c. Plug the module back into the AC outlet with the button pressed

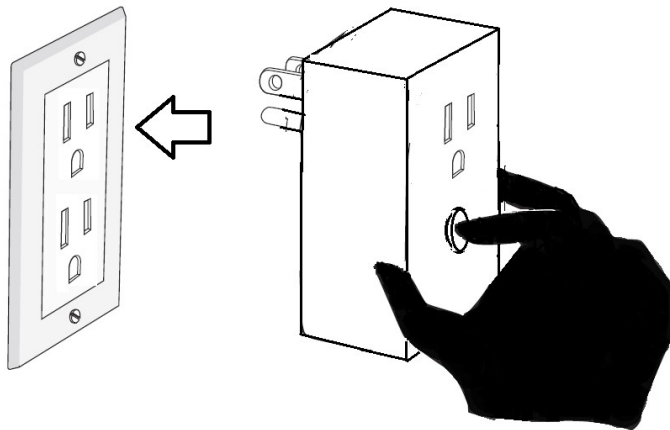

After 3 seconds, release the button. If you see the button blinks, that means the module has been reset successfully and you may retry Step 3 above to add the module into your network.

Before repeating the above steps, try moving the PA-100 to an AC outlet in the same room as your home gateway in case the preferred outlet is out of range initially. Repeat Steps 1-3 until the PA-100 is added to your network. Once the PA-100 has been successfully added to your home network, you can move it to the preferred location in the home.

Note: Once the PA-100 is Added (Included) in your network, resetting it locally does not mean it has been removed from your network. If you wish to remove PA-100 from your network, you will need to Delete(Exclude) the module from the network by your controller.

## BASIC OPERATION

The connected appliance can be controlled manually with a push button

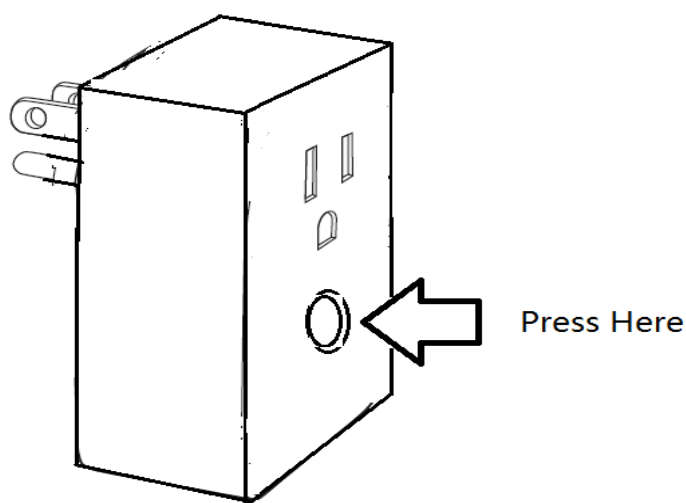

OR

Wirelessly with a remote controller

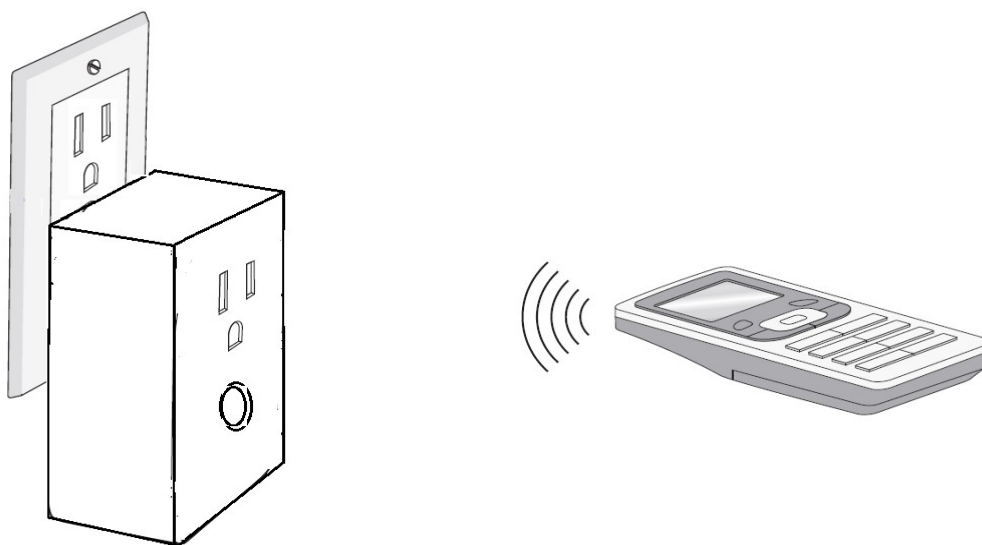

Once the PA-100 has been added to your network, you may assign it to a Group or Scene, change its status when the All ON or OFF command is received from the controller. It can also be set in Association with another Z-Wave device to perform a specific duty. Please refer to the instructions manual of your gateway or remote controller for detail procedures on how these functions can be set.

About the push button:

There is a single button on PA-100 for manual operation that:

- A) Manually turns the connected appliance ON/OFF by pressing the button. It functions as a toggle switch; if the appliance is ON, pressing the button turns the appliance OFF and vice versa.
- B) Adds (Includes) or Deletes (Excludes) your PA-100 to/from your Z-Wave network. Please refer to the instructions manual of your gateway or remote controller for detail procedures on how these actions can be done.

This push button is also backlit with an LED indicator that will be ON whenever the connected appliance is Off, and turns OFF when the connected device is ON. By changing the following configuration with your primary controller (if supported), the default status of the LED indicator can be changed as follows:

Parameter 3                  Length: 1 Byte                  Valid Values: 0, 1 or 2 (default = 0)  
When value = 1, the LED indicator will be ON when the connected appliance is ON, and the LED indicator will be OFF when the connected appliance is OFF  
When value = 2, the LED indicator is always OFF regardless of the load condition

About the Z-Wave 500 Series module with Z-Wave Plus features:

You can use a Z-Wave certified portable or static controller to communicate with the module. Depending on the capability of your controller or gateway software, the following simple to advanced operations can be performed. Please refer to the controller or gateway's manual for details.

1. Turn the appliance On/Off
2. Add(Include) or Delete(Exclude) your PA-100 to/from your network
3. Assign your PA-100 to a specific Group/Scene and/or to include your PA-100 as part of your All ON or OFF command
4. Over-the-Air firmware update by your gateway or static controller
5. Lifeline function which automatically notifies the associated modules and the network that a manually reset device is no longer in the network, thus, the corresponding association becomes invalid

Please note that the module will be OFF after a power failure

## SPECIFICATIONS

Model: PA-100

Input power: 120 VAC, 60 Hz.

Max output loading: 900W incandescent, 200W CFL/LED, ½ horsepower motor and 15A, 1800W resistive load.

Radio frequency: 908.4 MHz/916 MHz.

Wireless range: up to 130 ft line of sight between the controller and the other available nodes.

Normal operating temperature: 77°F (25°C)

For indoor use only.

## Interoperability with Z-Wave devices

A Z-Wave network can integrate devices from various classes of products, and these devices can be made by different manufacturers. The domitech product introduced in this instructions manual has a Z-Wave certification which guarantees such an interoperability.

FCC ID: 2ABWCPA100

The Federal Communication Commission Radio Frequency Interference Statement includes the following paragraph:

The equipment has been tested and found to comply with the limits for a Class B Digital Device, pursuant to part 15 of the FCC Rules. These limits are designed to provide reasonable protection against harmful interference in a residential installation. This equipment uses, generates and can radiate radio frequency energy and, if not installed and used in accordance with the instruction, may cause harmful interference to radio communication. However, there is no guarantee that interference will not occur in a particular installation. If this equipment does cause harmful interference to radio or television reception, which can be determined by turning the equipment off and on, the user is encouraged to try to correct the interference by one or more of the following measures:

- Reorient or relocate the receiving antenna
- Increase the separation between the equipment and receiver
- Connect the equipment into an outlet on a circuit different from that to which the receiver is connected
- Consult the dealer or an experienced radio/TV technician for help

Operation is subject to the following two conditions:

- This device may not cause interference
- This device must accept any interference, including interference that may cause undesired operation of the device.

**Important Note:** To comply with the FCC RF exposure compliance requirements, no change to the antenna or the device is permitted. Any change to the antenna or the device could result in the device exceeding the RF exposure requirements and void user's authority to operate the device.

**Caution:** Exposure to Radio Frequency Radiation. To comply with FCC/IC RF exposure compliance requirements, a separation distance of at least 20 cm must be maintained between the antenna of this device and all persons. This device must not be co-located or operating in conjunction with any other antenna or transmitter.

IC: 11786A-PA100

This device complies with Industry Canada license-exempt RSS standard(s). Operation is subject to the following two conditions:

- (1) this device may not cause interference, and
- (2) this device must accept any interference, including interference that may cause undesired operation of the device.

Z-Wave is a registered trademark of Sigma Design

## WARRANTY

domitech warrants to the original purchaser of this product that for the warranty period, this

product will be free from material defects in materials and workmanship. The foregoing warranty is subject to the proper installation, operation and maintenance of the product in accordance with installation instructions and the operating manual supplied to customer. Warranty claims must be made by customer in writing within 30 days of the manifestation of a problem. domitech's sole obligation under the foregoing warranty is to repair, replace or correct any such defect that was present at the time of delivery, or to remove the product and to refund the purchase price to customer. The warranty does not extend to consequential or incidental damage to other products that may be used with this product. For inquiry and customer service, email to [support@dragontechind.com](mailto:support@dragontechind.com)

All brand names shown are trademarks of their respective owners

Warranty period: limited 1 year from date of purchase

domitech Products  
2140 E. Southlake Blvd., Suite L-312  
Southlake, TX 76092

PA100\_07022014\_En\_v1.2