

GOLD'S GYM®

XRS 20

Model No. GGBE1486.1

Serial No. _____

Write the serial number in the space above for future reference.

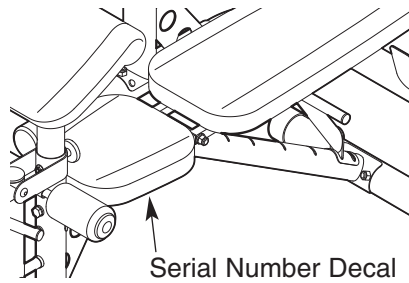

QUESTIONS?

As a manufacturer, we are committed to providing complete customer satisfaction. If you have questions, or if a part is damaged or missing, PLEASE CONTACT OUR CUSTOMER SERVICE DEPARTMENT DIRECTLY.

CALL TOLL-FREE:

1-877-776-4777

Mon.–Fri., 6 a.m.–6 p.m. MST

ON THE WEB:

www.goldsgympowerflex.com

CAUTION

Read all precautions and instructions in this manual before using this equipment. Save this manual for future reference.

USER'S MANUAL



GOLD'S GYM[®]

XRS 20

TABLE OF CONTENTS

| | |
|----------------------------------|------------|
| IMPORTANT PRECAUTIONS | 3 |
| BEFORE YOU BEGIN | 4 |
| PART IDENTIFICATION CHART | 5 |
| ASSEMBLY | 6 |
| ADJUSTMENTS | 11 |
| EXERCISE GUIDELINES | 13 |
| PART LIST | 17 |
| EXPLODED DRAWING | 18 |
| ORDERING REPLACEMENT PARTS | Back Cover |
| LIMITED WARRANTY | Back Cover |

IMPORTANT PRECAUTIONS

⚠ WARNING: To reduce the risk of serious injury, read the following important precautions before using the weight bench.

1. Read all instructions in this manual and all warnings on the weight bench before using the weight bench. Use the weight bench only as described in this manual.
2. It is the responsibility of the owner to ensure that all users of the weight bench are adequately informed of all precautions.
3. The weight bench is intended for home use only. Do not use the weight bench in any commercial, rental, or institutional setting.
4. Keep the weight bench indoors, away from moisture and dust. Place the weight bench on a level surface, with a mat beneath it to protect the floor or carpet. Make sure that there is enough clearance around the weight bench to mount, dismount, and use it.
5. Keep children under 12 and pets away from the weight bench at all times.
6. Inspect and properly tighten all parts regularly. Replace any worn parts immediately.
7. Always make sure that the backrest post is fully engaged in a slot in the frame before using the backrest.
8. Wear appropriate clothes while exercising. Always wear athletic shoes for foot protection while exercising.
9. The weight bench is designed to support a maximum user weight of 300 pounds and a maximum total weight of 610 pounds. Do not use the weight bench with more than 310 pounds of weight. Do not place more than 150 pounds on the leg lever. Note: The weight bench does not include weights.
10. If you feel pain or dizziness at any time while exercising, stop immediately and begin cooling down.
11. The decals shown below have been placed on the weight bench. If a decal is missing or illegible, call the toll-free telephone number on the front cover of this manual and order a free replacement decal. Apply the decal in the location shown.

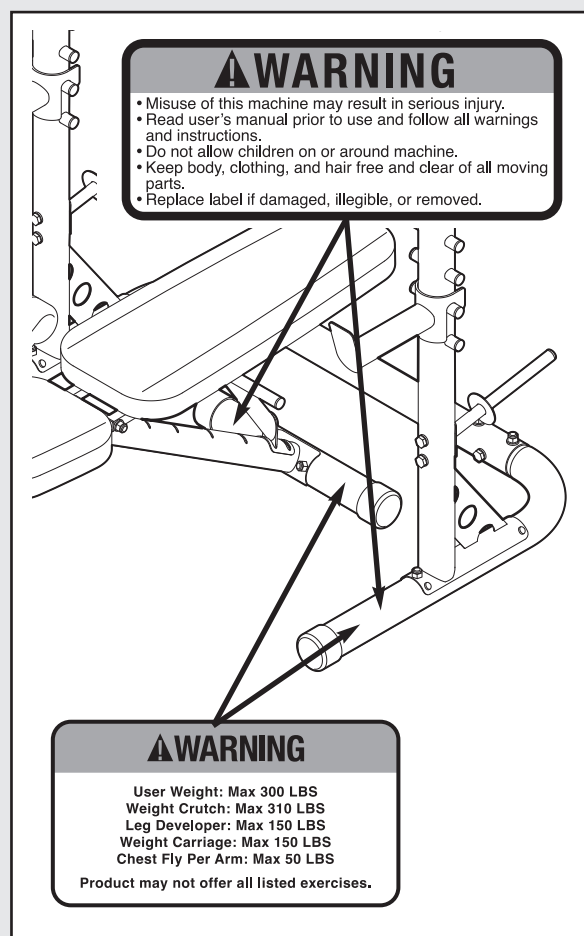

⚠ WARNING: Before beginning this or any exercise program, consult your physician. This is especially important for persons over the age of 35 or persons with pre-existing health problems. Read all instructions before using. ICON assumes no responsibility for personal injury or property damage sustained by or through the use of this product.

BEFORE YOU BEGIN

Thank you for selecting the versatile GOLD'S GYM® XRS 20 weight bench. The weight bench offers a selection of exercise stations designed to develop the major muscle groups of the body. Whether your goal is to tone your body, build dramatic muscle size and strength, or improve your cardiovascular system, the weight bench will help you to achieve the specific results you want.

For your benefit, read this manual carefully before using the weight bench. If you have questions after reading this manual, please see the front cover of this

manual. To help us assist you, please note the product model number and serial number before contacting us. The model number is GGBE1486.1. The serial number can be found on a decal attached to the weight bench (see the front cover of this manual).

To avoid a registration fee for any service needed under warranty, you must register the weight bench at www.iconservice.com/registration.

Before reading further, please review the drawing below and familiarize yourself with the parts that are labeled.

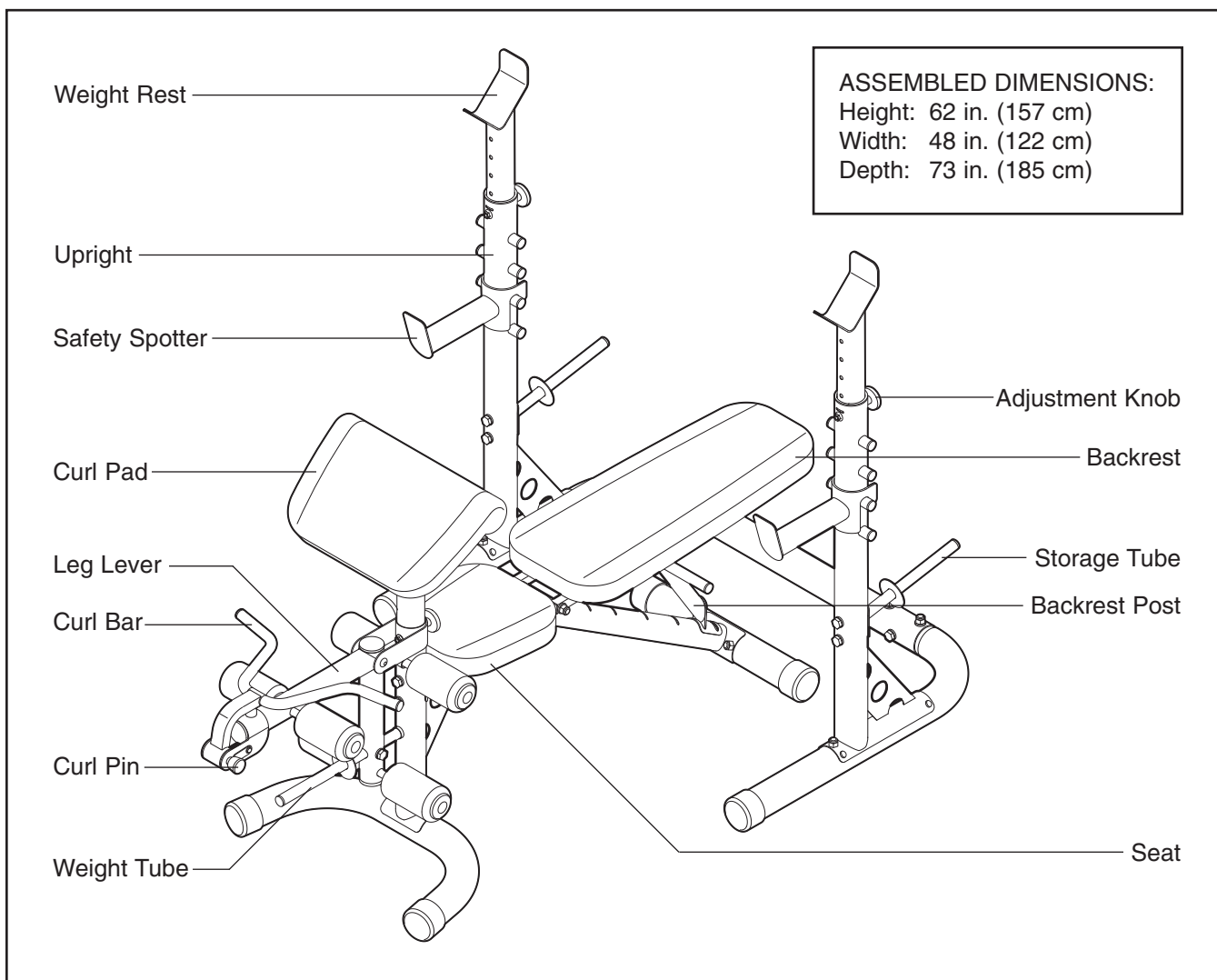

PART IDENTIFICATION CHART

See the drawings below to identify small parts used in assembly. The number in parentheses by each drawing is the key number of the part, from the PART LIST on page 17. **Note: Some small parts may have been pre-attached. If a part is not in the parts bag, check to see if it has been preattached.**

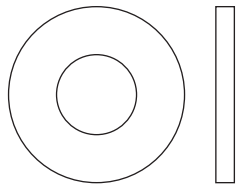

M10 Washer (52)



M4 x 16mm
Screw (51)

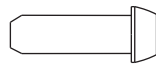

M5 x 16mm
Screw (50)



M6 x 16mm
Screw (47)

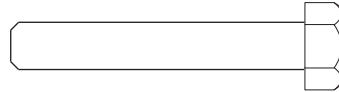

M6 x 40mm Screw (48)

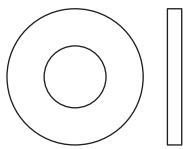

M8 Washer (54)

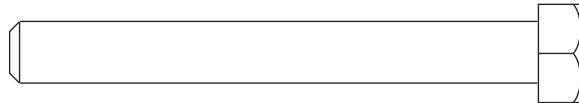

M8 x 70mm Bolt (44)

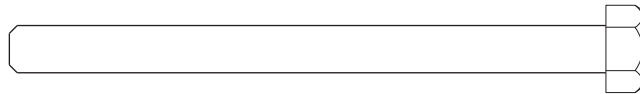

M6 x 80mm Screw (46)

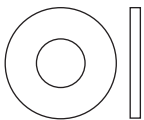

M6 Washer (53)

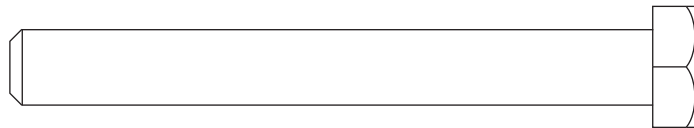

M10 x 85mm Bolt (43)

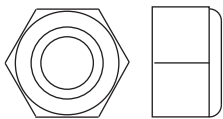

M10 Nylon
Locknut (57)

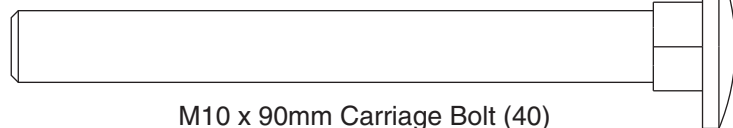

M10 x 90mm Carriage Bolt (40)

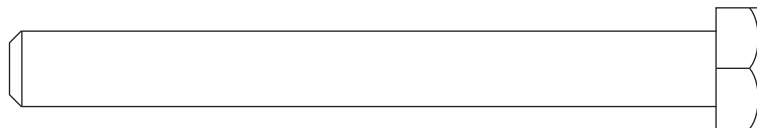

M10 x 95mm Bolt (42)

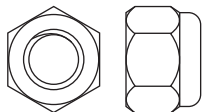

M8 Nylon
Locknut (58)

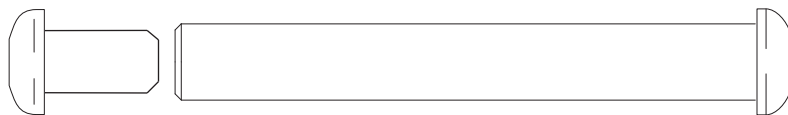

M10 x 77mm Bolt Set (45)

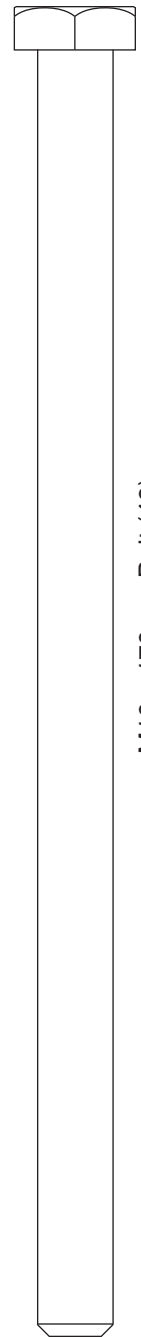

M10 x 170mm Bolt (49)

ASSEMBLY

Make Assembly Easier

Everything in this manual is designed to ensure that the weight bench can be assembled successfully by almost anyone. However, the weight bench has many parts and the assembly process will take time. By setting aside plenty of time, assembly will go smoothly.





To hire an authorized service technician to assemble the weight bench, call toll-free 1-800-445-2480.

Before beginning assembly, carefully read the following information and instructions:

- Because of its weight and size, the weight bench should be assembled in the location where it will be used. Make sure that there is enough clearance to walk around the weight bench as you assemble it.
- Place all parts in a cleared area and remove the packing materials. Do not dispose of the packing materials until assembly is completed.

- Tighten all parts as you assemble them, unless instructed to do otherwise.
- As you assemble the weight bench, make sure all parts are oriented as shown in the drawings.
- Assembly requires two persons.
- **For help identifying small parts, use the PART IDENTIFICATION CHART on page 5.**

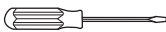
In addition to the included grease, assembly may require the following tools (not included):

- two adjustable wrenches 
- one rubber mallet 
- one standard screwdriver 
- one Phillips screwdriver 

Assembly may be more convenient if you have a socket set, a set of open-end or closed-end wrenches, or a set of ratchet wrenches.

1. Before beginning assembly, make sure that you have read and understand the information in the box above. See the **PART IDENTIFICATION CHART** on page 5 for help identifying small parts.

Orient the Front Stabilizer (2) with the square holes toward the floor. Attach the Front Stabilizer (2) to the Front Leg (4) with two M10 x 90mm Carriage Bolts (40) and two M10 Nylon Locknuts (57). **Do not tighten the Nylon Locknuts yet.**

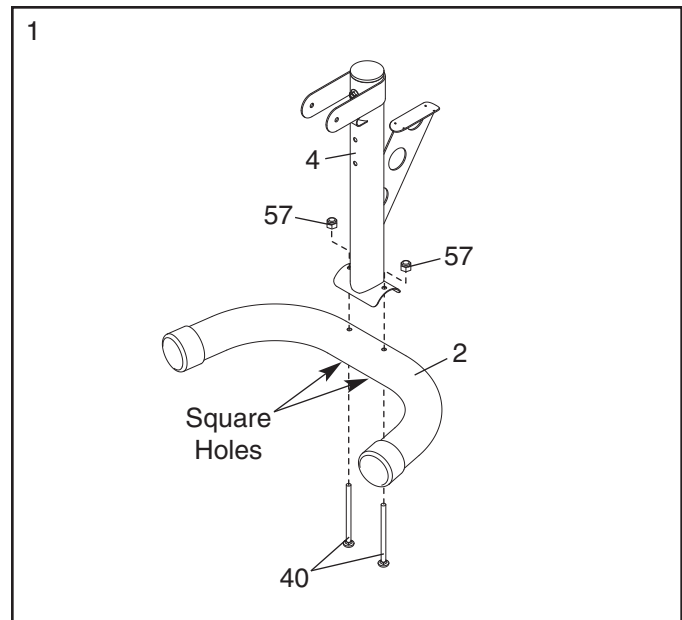

- Attach the Rear Stabilizer (3) to the Frame (1) with two M10 x 90mm Carriage Bolts (40) and two M10 Nylon Locknuts (57). **Do not tighten the Nylon Locknuts yet.**

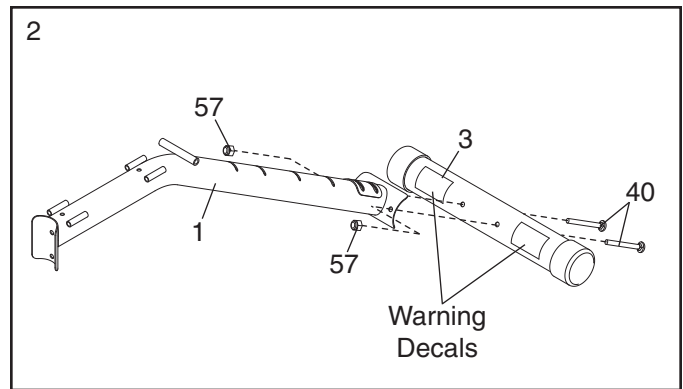

- Attach the Seat (18) and the Seat Bracket (59) to the Frame (1) with two M6 x 80mm Screws (46) and two M6 Washers (53).

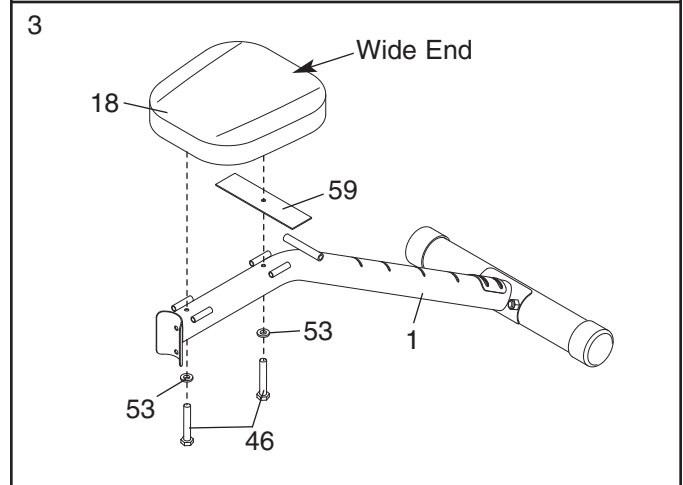

- Attach the Frame (1) to the Front Leg (4) with two M10 x 85mm Bolts (43), two M10 Washers (52), and an M10 Nylon Locknut (57). **Do not tighten the Nylon Locknut yet.**

Finish attaching the Front Leg (4) to the Frame (1) with four M5 x 16mm Screws (50). **Tighten the Nylon Locknuts (57) used in steps 1, 2, and 4.**

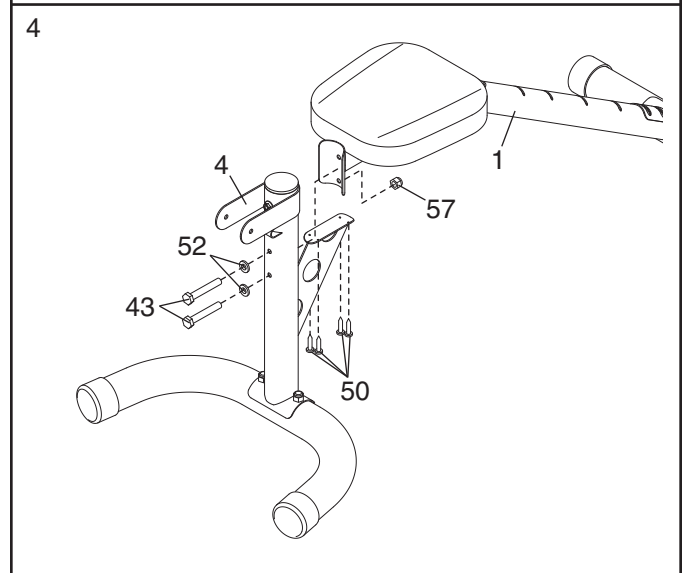

- Apply a portion of the included grease to an M10 x 170mm Bolt (49). Attach the Backrest Post (15) to the Backrest Frames (16) with the Bolt, two M10 Washers (52), and an M10 Nylon Locknut (57). **Do not tighten the Nylon Locknut yet.**

Attach the Backrest (19) to the Backrest Frames (16) with four M6 x 40mm Screws (48) and four M6 Washers (53). **Do not tighten the Screws yet.**

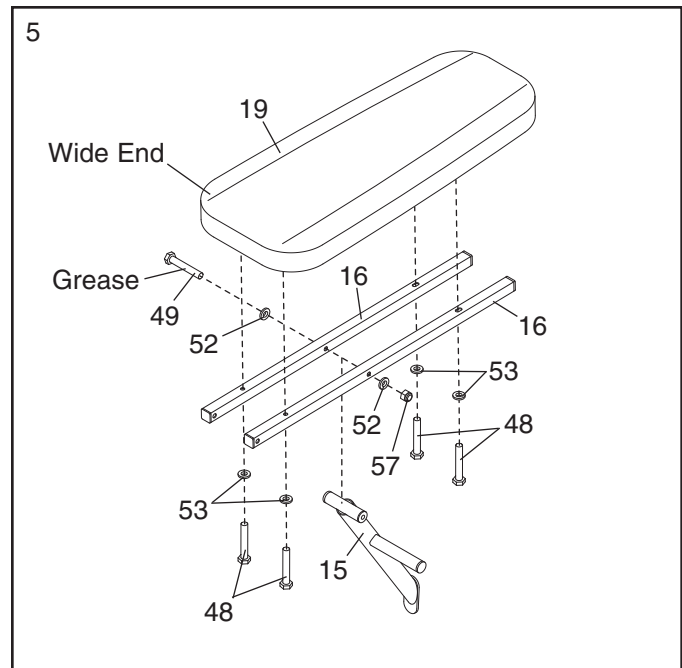

- Apply a portion of the included grease to an M10 x 170mm Bolt (49). Attach the Backrest Frames (16) to the Frame (1) with the Bolt, two M10 Washers (52), and an M10 Nylon Locknut (57). Set the end of the Backrest Post (15) in one of the slots in the Frame. **Do not over-tighten the Nylon Locknut; the Backrest Frames must pivot easily.**

See step 5. Tighten the M10 Nylon Locknut (57) and the four M6 x 40mm Screws (48). **Do not over-tighten the Nylon Locknut; the Backrest Post (15) must pivot easily.**

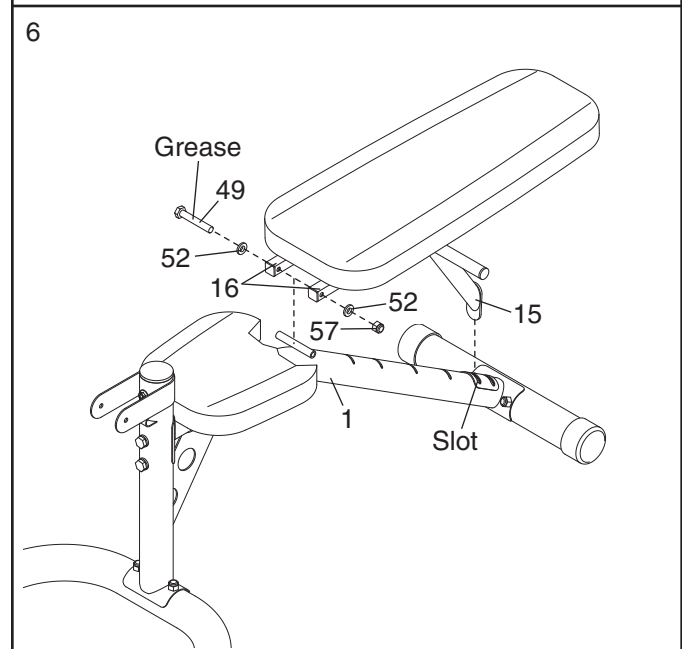

- Attach the Weight Tube (24) to the Leg Lever (5) with an M8 x 70mm Bolt (44), a 13mm x 16mm Spacer (55), two M8 Washers (54), and an M8 Nylon Locknut (58). Next, press a 25mm Outer Cap (56) onto the end of the Weight Tube.

Apply grease to the barrel of an M10 x 77mm Bolt Set (45). Attach the Leg Lever (5) to the Front Leg (4) with the Bolt Set. **Make sure that the barrel of the Bolt Set is inserted through both sides of the bracket on the Front Leg.**

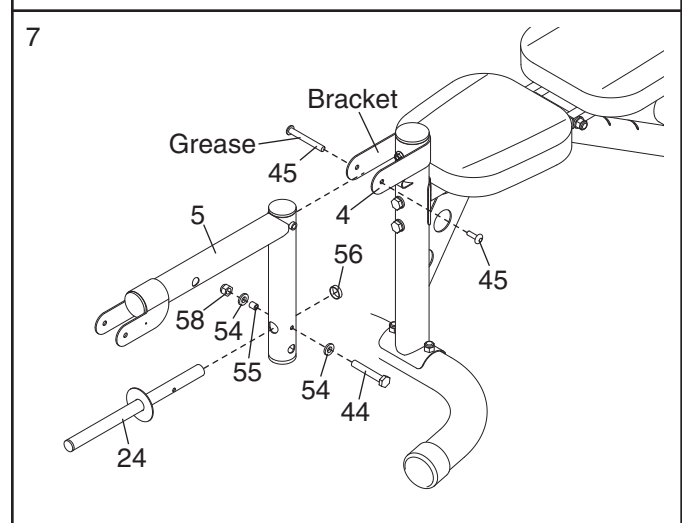

8. Insert the Long Pad Tube (36) into the bracket on the Front Leg (4). Slide two Foam Pads (22) onto the Pad Tube, and press two Pad Caps (23) into the ends of the Foam Pads.

Repeat this step with the two Short Pad Tubes (21) and the Leg Lever (5).

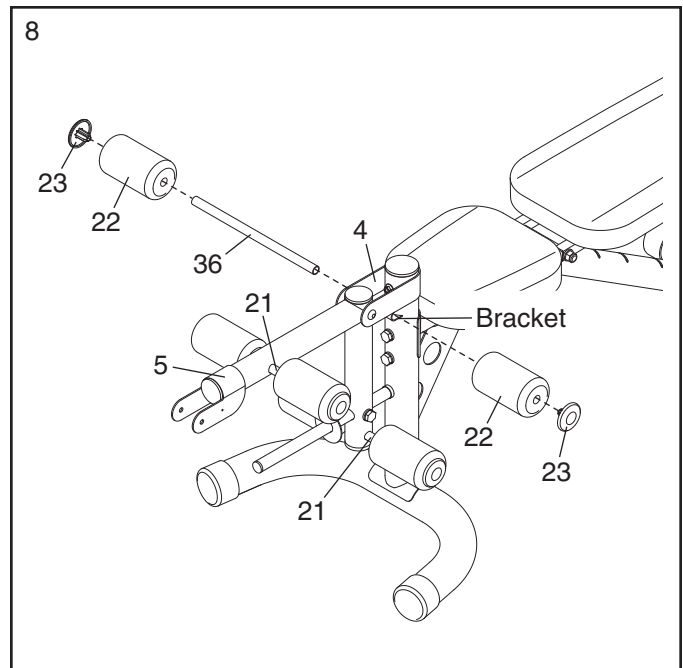

9. Attach the Bumper (30) to the Curl Bar (17) with an M4 x 16mm Screw (51).

Attach the Curl Bar (17) to the Leg Lever (5) with the Curl Bar Pin (33). Then, attach the Tether (34) on the Curl Bar Pin to the Leg Lever with an M4 x 16mm Screw (51).

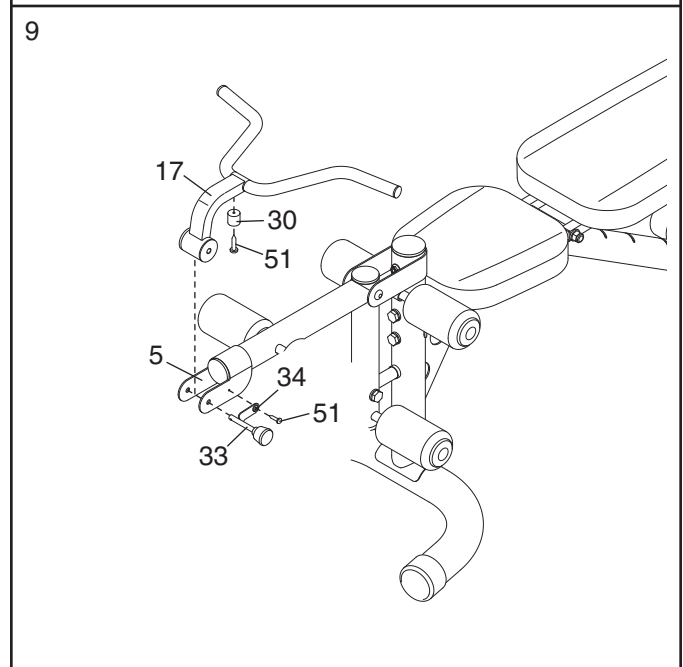

10. Attach the Curl Pad (20) to the Curl Post (6) with two M6 x 16mm Screws (47).

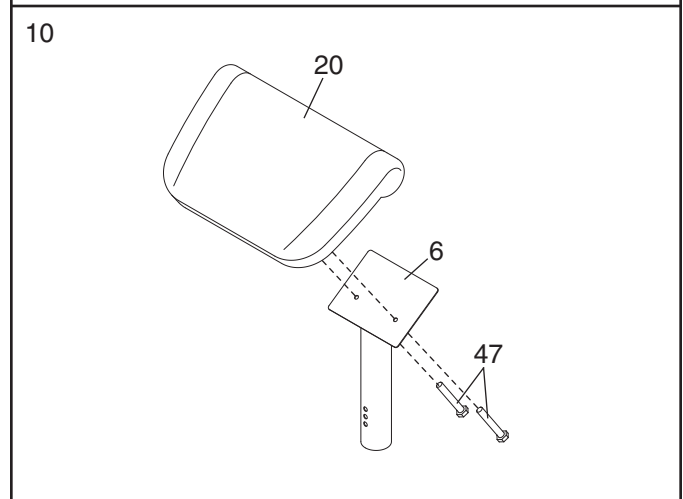

11. Note: If you have Olympic weights, use the Long Base (7) in this step; if you do not have Olympic weights, use the Short Base (8). For simplicity, the Long Base is shown in all drawings in this manual.

Attach a Foot (39) to the Left Upright Base (9) with an M5 x 16mm Screw (50). Insert an M10 x 90mm Carriage Bolt (40) up into the Upright Base.

Attach the Left Upright Base (9) to the Long Base (7) with two M10 x 90mm Carriage Bolts (40), an M10 x 95mm Bolt (42), four M10 Washers (52), and three M10 Nylon Locknuts (57). **Do not tighten the Nylon Locknuts yet.**

Repeat this step for the Right Upright Base (10).

12. Attach a Storage Tube (14) to an Upright (11) with two M10 x 95mm Bolts (42), two M10 Washers (52), and two M10 Nylon Locknuts (57).

Attach the Upright (11) to the Left Upright Base (9) with the M10 x 90mm Carriage Bolt (40), four M5 x 16mm Screws (50), and an M10 Nylon Locknut (57).

Repeat this step for the other Upright (11) and the Right Upright Base (10).

See step 11. Tighten all of the M10 Nylon Locknuts (57) used in step 11.

13. Set a Safety Spotter (13) on a set of pegs on the left Upright (11).

Set the other Safety Spotter (13) on a set of pegs on the right Upright (11). **Make sure that both Safety Spotters are at the same height.**

14. **Make sure that all parts are properly tightened before you use the weight bench. The use of all remaining parts will be explained in ADJUSTMENTS on pages 11 and 12.**

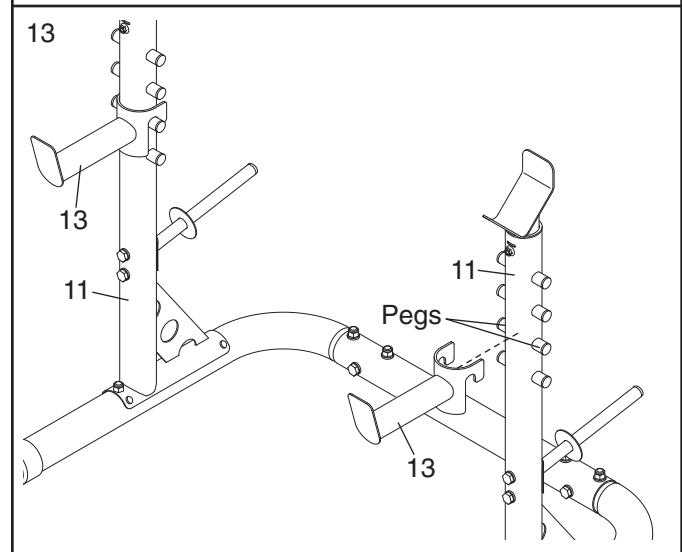
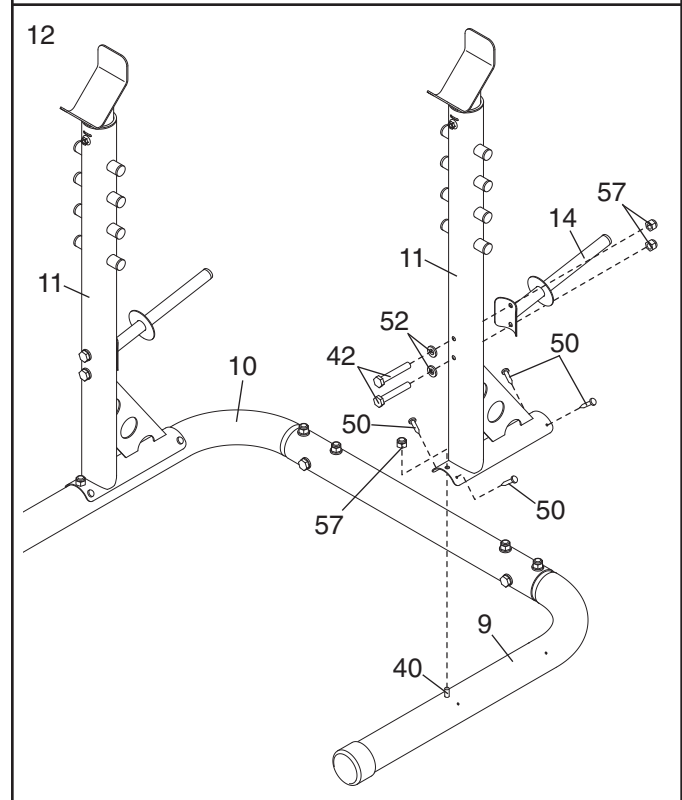
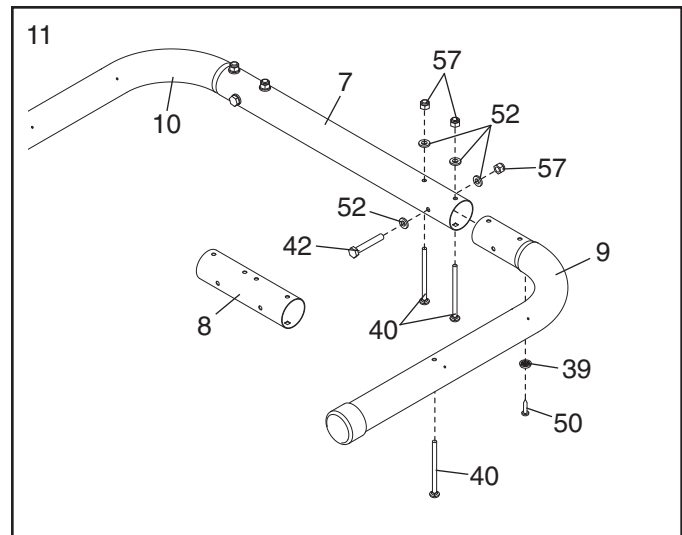

ADJUSTMENTS

This section explains how to adjust the weight bench. See the EXERCISE GUIDELINES on page 13 for important information about how to get the most benefit from your exercise program. Also, refer to the accompanying exercise guide to see the correct form for each exercise.

Make sure all parts are properly tightened each time you use the weight bench. Replace any worn parts immediately. The weight bench can be cleaned with a damp cloth and a mild, non-abrasive detergent. Do not use solvents.

USING THE CURL PAD

To use the Curl Pad (20), remove the indicated 70mm Round Inner Cap (26) and insert the Curl Post (6) into the Front Leg (4). Tighten an Adjustment Knob (35) into the Front Leg. **Make sure that the Adjustment Knob passes through a hole in the Curl Post.**

When performing exercises that do not require the Curl Pad (20), remove the Curl Pad and reinsert the 70mm Round Inner Cap (26) into the Front Leg (4).

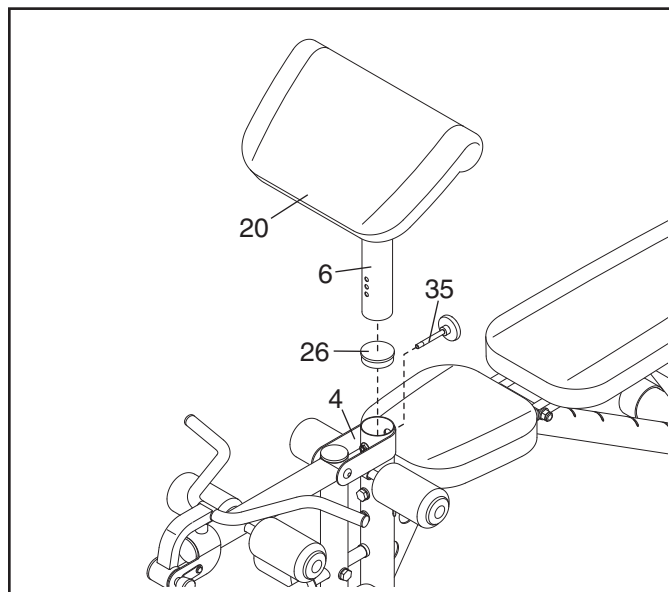

ADJUSTING THE BACKREST

To adjust the position of the Backrest (19), lift the indicated handle on the Backrest Post (15). Raise or lower the Backrest, and set the Backrest Post in one of the slots in the Frame (1). **Make sure that the Backrest Post is fully inserted into one of the slots.**

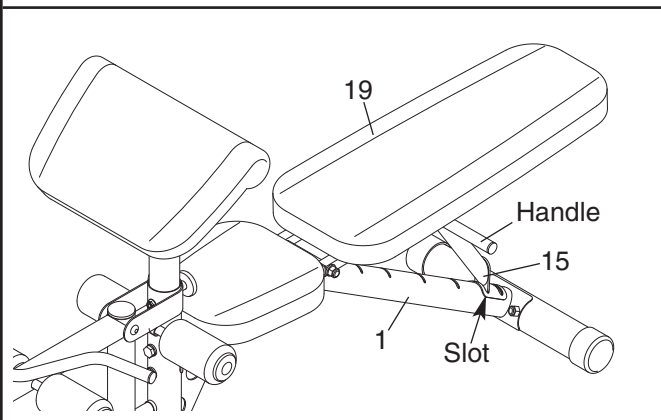

USING THE LEG LEVER

The Leg Lever (5) can be used with standard weights or Olympic weights. To use the Leg Lever, slide a weight plate (not shown) onto the Weight Tube (24) and secure it with a 1" Weight Clip (41). **Note: When using the Leg Lever, remove the Curl Bar (17) (see REMOVING THE CURL BAR on page 12).**

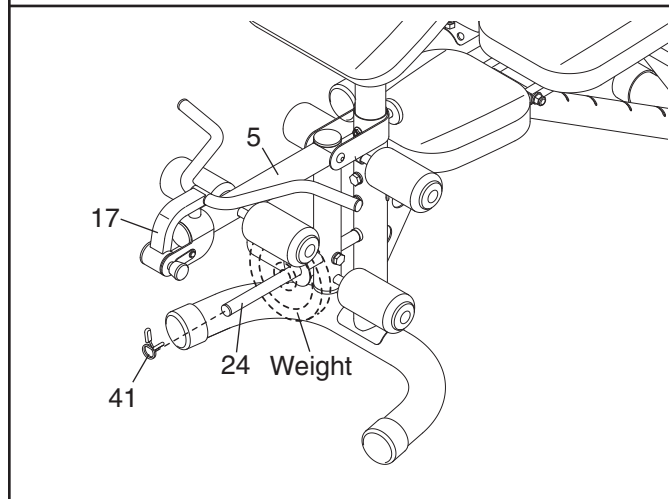

REMOVING THE CURL BAR

When performing exercises that do not require the Curl Bar (17), pull the Curl Bar Pin (33) out of the Leg Lever (5) and remove the Curl Bar.

When attaching the Curl Bar (17), insert the Curl Bar Pin (33) completely through the Leg Lever (5).

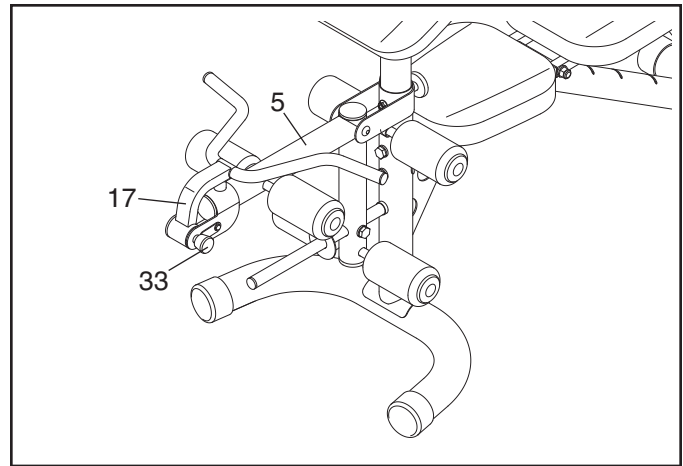

ADJUSTING THE WEIGHT RESTS AND THE SAFETY SPOTTERS

To adjust the height of the Weight Rests (12), raise the Weight Rests to the desired height and tighten an Adjustment Knob (35) into each Upright (11).

Make sure that the Weight Rests are at the same height and that the Adjustment Knobs are fully tightened into the Uprights.

To adjust the position of the Safety Spotters (13), move the Safety Spotters to a different set of pegs on the Uprights (11). **Make sure that the Safety Spotters are at the same height.**

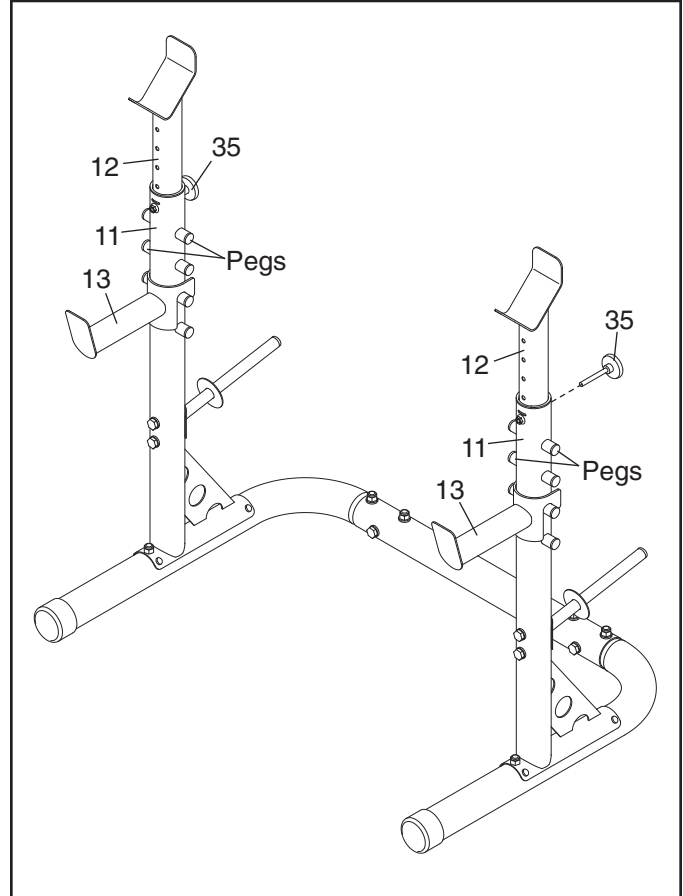

EXERCISE GUIDELINES

THE FOUR BASIC TYPES OF WORKOUTS

Muscle Building

To increase the size and strength of your muscles, push them close to their maximum capacity. Your muscles will continually adapt and grow as you progressively increase the intensity of your exercise. You can adjust the intensity level of an individual exercise in two ways:

- by changing the amount of resistance used
- by changing the number of repetitions or sets performed. (A “repetition” is one complete cycle of an exercise, such as one sit-up. A “set” is a series of repetitions.)

The proper amount of resistance for each exercise depends upon the individual user. You must gauge your limits and select the amount of resistance that is right for you. Begin with 3 sets of 8 repetitions for each exercise you perform. Rest for 3 minutes after each set. When you can complete 3 sets of 12 repetitions without difficulty, increase the amount of resistance.

Toning

You can tone your muscles by pushing them to a moderate percentage of their capacity. Select a moderate amount of resistance and increase the number of repetitions in each set. Complete as many sets of 15 to 20 repetitions as possible without discomfort. Rest for 1 minute after each set. Work your muscles by completing more sets rather than by using high amounts of resistance.

Weight Loss

To lose weight, use a low amount of resistance and increase the number of repetitions in each set. Exercise for 20 to 30 minutes, resting for a maximum of 30 seconds between sets.

Cross Training

Cross training is an efficient way to get a complete and well-balanced fitness program. An example of a balanced program follows:

- Plan strength training workouts on Monday, Wednesday, and Friday.
- Plan 20 to 30 minutes of aerobic exercise, such as running on a treadmill or riding on an elliptical exerciser or exercise cycle, on Tuesday and Thursday.
- Rest from both strength training and aerobic exercise for at least one full day each week to give your body time to regenerate.

The combination of strength training and aerobic exercise will reshape and strengthen your body, plus develop your heart and lungs.

PERSONALIZING YOUR EXERCISE PROGRAM

Determining the exact length of time for each workout, as well as the number of repetitions or sets completed, is an individual matter. It is important to avoid overdoing it during the first few months of your exercise program. You should progress at your own pace and be sensitive to your body’s signals. If you experience pain or dizziness at any time while exercising, stop immediately and begin cooling down. Find out what is wrong before continuing. Remember that adequate rest and a proper diet are important factors in any exercise program.

WARMING UP

Begin each workout with 5 to 10 minutes of stretching and light exercise to warm up. Warming up prepares your body for more strenuous exercise by increasing circulation, raising your body temperature and delivering more oxygen to your muscles.

WORKING OUT

Each workout should include 6 to 10 different exercises. Select exercises for every major muscle group, emphasizing areas that you want to develop most. To give balance and variety to your workouts, vary the exercises from session to session.

Schedule your workouts for the time of day when your energy level is the highest. Each workout should be followed by at least one day of rest. Once you find the schedule that is right for you, stick with it.

EXERCISE FORM

Maintaining proper form is an essential part of an effective exercise program. This requires moving through the full range of motion for each exercise, and moving only the appropriate parts of the body. Exercising in an uncontrolled manner will leave you feeling exhausted. On the exercise guide accompanying this manual you will find photographs showing the correct form for several exercises, and a list of the muscles affected. Refer to the muscle chart on the next page to find the names of the muscles.

The repetitions in each set should be performed smoothly and without pausing. The exertion stage of each repetition should last about half as long as the return stage. Proper breathing is important. Exhale during the exertion stage of each repetition and inhale during the return stroke. Never hold your breath.

Rest for a short period of time after each set. The ideal resting periods follow:

- Rest for three minutes after each set for a muscle building workout.
- Rest for one minute after each set for a toning workout.
- Rest for 30 seconds after each set for a weight loss workout.

Plan to spend the first couple of weeks familiarizing yourself with the equipment and learning the proper form for each exercise.

COOLING DOWN

End each workout with 5 to 10 minutes of stretching. Include stretches for both your arms and legs. Move

slowly as you stretch and do not bounce. Ease into each stretch gradually and go only as far as you can without strain. Stretching at the end of each workout is an effective way to increase flexibility.

STAYING MOTIVATED

For motivation, keep a record of each workout. List the date, the exercises performed, the resistance used, and the numbers of sets and repetitions completed. Make copies of the exercise logs found on pages 15 and 16. Use the logs to record your weight and key body measurements at the end of every month.

Remember, the key to achieving the greatest results is to make exercise a regular and enjoyable part of your everyday life.

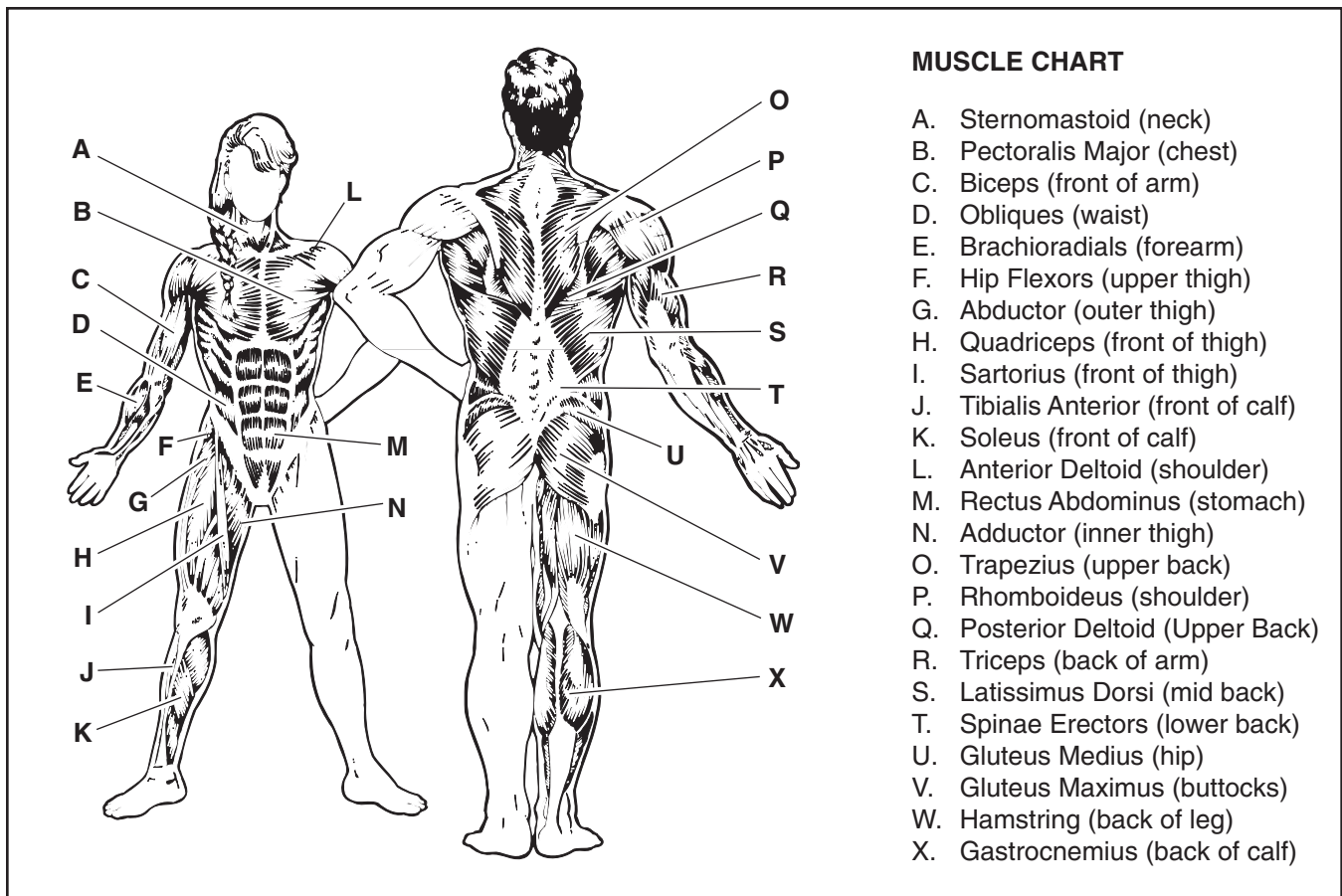

| MONDAY | EXERCISE | WEIGHT | SETS | REPS |
|-----------------------------|-----------------|---------------|-------------|-------------|
| Date: _____ / _____ / _____ | | | | |
| | | | | |
| | | | | |
| | | | | |
| | | | | |
| | | | | |
| | | | | |
| | | | | |
| | | | | |
| | | | | |

TUESDAY AEROBIC EXERCISE

Date: _____ / _____ / _____

| WEDNESDAY | EXERCISE | WEIGHT | SETS | REPS |
|-----------------------------|-----------------|---------------|-------------|-------------|
| Date: _____ / _____ / _____ | | | | |
| | | | | |
| | | | | |
| | | | | |
| | | | | |
| | | | | |
| | | | | |
| | | | | |
| | | | | |
| | | | | |

THURSDAY AEROBIC EXERCISE

Date: _____ / _____ / _____

| FRIDAY | EXERCISE | WEIGHT | SETS | REPS |
|-----------------------------|-----------------|---------------|-------------|-------------|
| Date: _____ / _____ / _____ | | | | |
| | | | | |
| | | | | |
| | | | | |
| | | | | |
| | | | | |
| | | | | |
| | | | | |
| | | | | |
| | | | | |

Make photocopies of this page for scheduling and recording your workouts.

| MONDAY | EXERCISE | WEIGHT | SETS | REPS |
|-----------------------------|-----------------|---------------|-------------|-------------|
| Date: _____ / _____ / _____ | | | | |
| | | | | |
| | | | | |
| | | | | |
| | | | | |
| | | | | |
| | | | | |
| | | | | |
| | | | | |
| | | | | |

TUESDAY AEROBIC EXERCISE

Date: _____ / _____ / _____

| WEDNESDAY | EXERCISE | WEIGHT | SETS | REPS |
|-----------------------------|-----------------|---------------|-------------|-------------|
| Date: _____ / _____ / _____ | | | | |
| | | | | |
| | | | | |
| | | | | |
| | | | | |
| | | | | |
| | | | | |
| | | | | |
| | | | | |
| | | | | |

THURSDAY AEROBIC EXERCISE

Date: _____ / _____ / _____

| FRIDAY | EXERCISE | WEIGHT | SETS | REPS |
|-----------------------------|-----------------|---------------|-------------|-------------|
| Date: _____ / _____ / _____ | | | | |
| | | | | |
| | | | | |
| | | | | |
| | | | | |
| | | | | |
| | | | | |
| | | | | |
| | | | | |
| | | | | |

Make photocopies of this page for scheduling and recording your workouts.

PART LIST—Model No. GGBE1486.1

R0806A

| Key No. | Qty. | Description | Key No. | Qty. | Description |
|---------|------|-----------------------|---------|------|--------------------------|
| 1 | 1 | Frame | 33 | 1 | Curl Bar Pin |
| 2 | 1 | Front Stabilizer | 34 | 1 | Tether |
| 3 | 1 | Rear Stabilizer | 35 | 3 | Adjustment Knob |
| 4 | 1 | Front Leg | 36 | 1 | Long Pad Tube |
| 5 | 1 | Leg Lever | 37 | 2 | Upright Bushing |
| 6 | 1 | Curl Post | 38 | 2 | Upright Spacer |
| 7 | 1 | Base | 39 | 2 | Foot |
| 8 | 1 | Short Base | 40 | 10 | M10 x 90mm Carriage Bolt |
| 9 | 1 | Left Upright Base | 41 | 1 | 1" Weight Clip |
| 10 | 1 | Right Upright Base | 42 | 6 | M10 x 95mm Bolt |
| 11 | 2 | Upright | 43 | 2 | M10 x 85mm Bolt |
| 12 | 2 | Weight Rest | 44 | 1 | M8 x 70mm Bolt |
| 13 | 2 | Safety Spotter | 45 | 1 | M10 x 77mm Bolt Set |
| 14 | 2 | Storage Tube | 46 | 2 | M6 x 80mm Screw |
| 15 | 1 | Backrest Post | 47 | 2 | M6 x 16mm Screw |
| 16 | 2 | Backrest Frame | 48 | 4 | M6 x 40mm Screw |
| 17 | 1 | Curl Bar | 49 | 2 | M10 x 170mm Bolt |
| 18 | 1 | Seat | 50 | 14 | M5 x 16mm Screw |
| 19 | 1 | Backrest | 51 | 6 | M4 x 16mm Screw |
| 20 | 1 | Curl Pad | 52 | 18 | M10 Washer |
| 21 | 2 | Short Pad Tube | 53 | 6 | M6 Washer |
| 22 | 6 | Foam Pad | 54 | 2 | M8 Washer |
| 23 | 6 | Pad Cap | 55 | 1 | 13mm x 16mm Spacer |
| 24 | 1 | Weight Tube | 56 | 1 | 25mm Outer Cap |
| 25 | 6 | 76mm Round Outer Cap | 57 | 19 | M10 Nylon Locknut |
| 26 | 1 | 70mm Round Inner Cap | 58 | 1 | M8 Nylon Locknut |
| 27 | 3 | 57mm Round Inner Cap | 59 | 1 | Seat Bracket |
| 28 | 22 | 25mm Round Inner Cap | # | — | User's Manual |
| 29 | 4 | 25mm Square Inner Cap | # | — | Exercise Guide |
| 30 | 1 | Bumper | # | — | Grease Packet |
| 31 | 2 | Curl Bushing | # | — | Hex Key |
| 32 | 2 | Backrest Bushing | | | |

Note: “#” indicates a non-illustrated part. Specifications are subject to change without notice. See the back cover of this manual for information about ordering replacement parts.

EXPLODED DRAWING—Model No. GGBE1486.1

R0906A

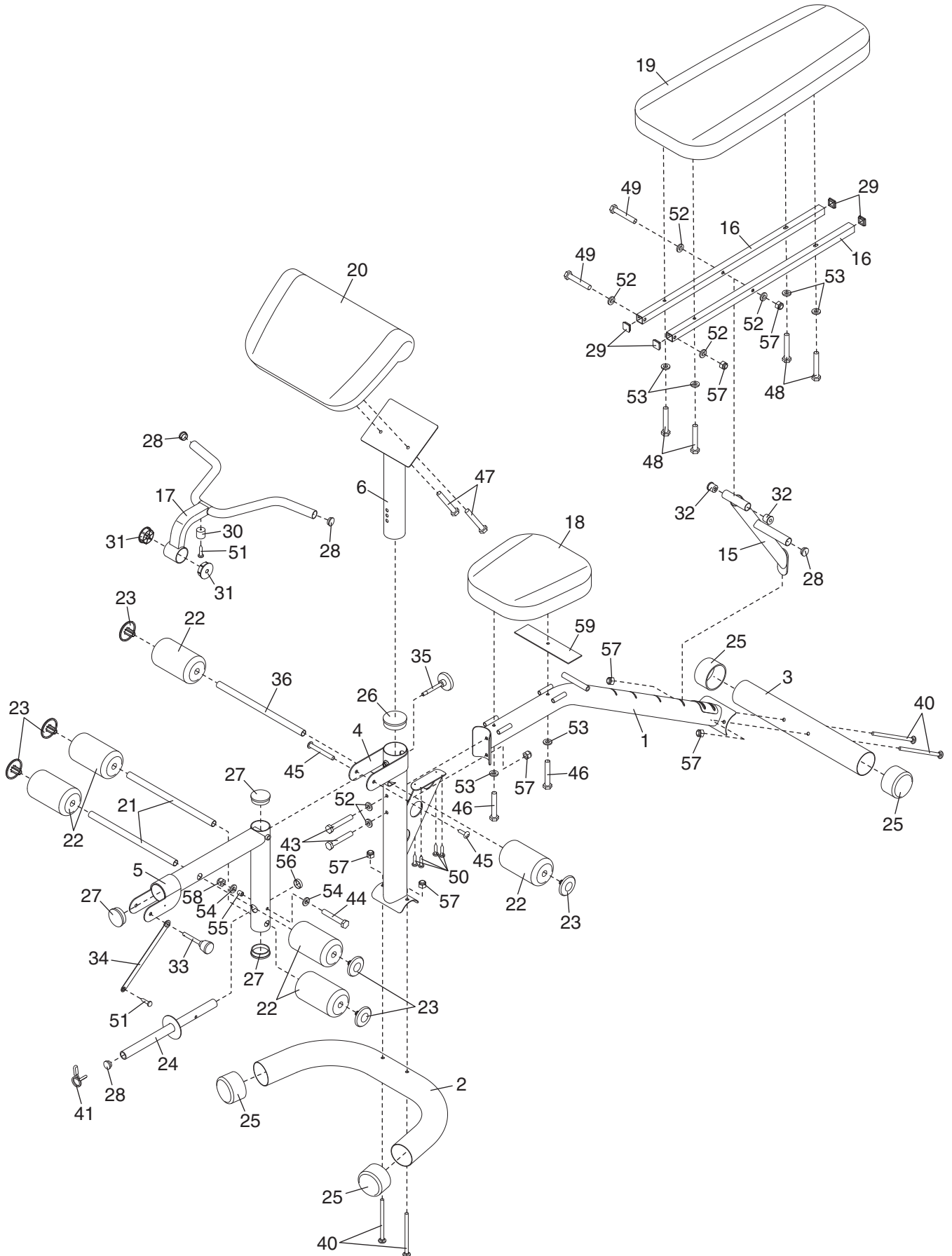

EXPLODED DRAWING—Model No. GGBE1486.1

R0906A

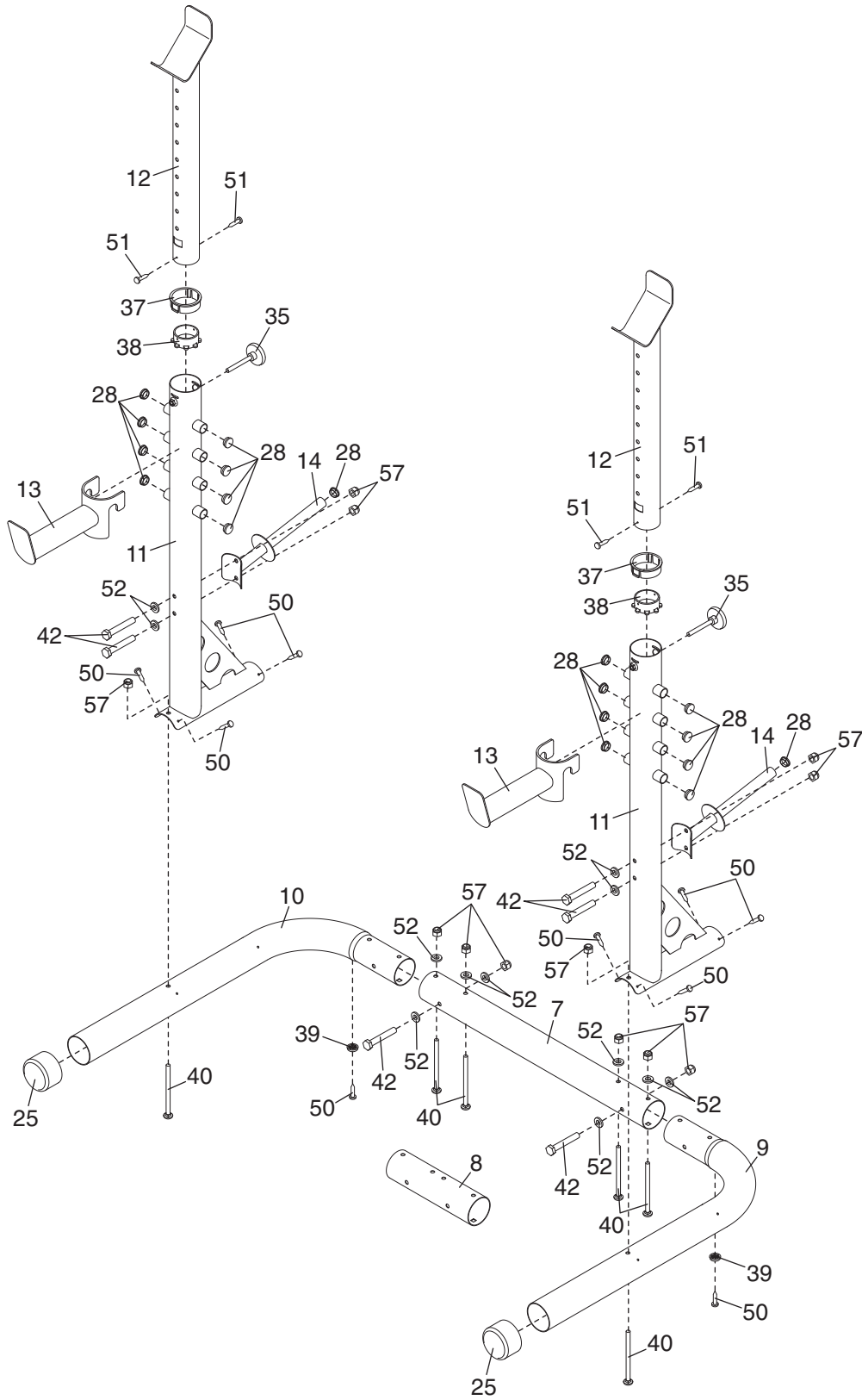

ORDERING REPLACEMENT PARTS

To order replacement parts, please see the front cover of this manual. To help us assist you, be prepared to provide the following information:

- the MODEL NUMBER of the product (GGBE1486.1)
- the NAME of the product (GOLD'S GYM XRS 20 weight bench)
- the SERIAL NUMBER of the product (see the front cover of this manual)
- the KEY NUMBER and DESCRIPTION of the part(s) (see the PART LIST and the EXPLODED DRAWING on pages 17, 18, and 19)

LIMITED WARRANTY

ICON Health & Fitness, Inc. (ICON) warrants this product to be free from defects in workmanship and material, under normal use and service conditions, for a period of ninety (90) days from the date of purchase. This warranty extends only to the original purchaser. ICON's obligation under this warranty is limited to replacing or repairing, at ICON's option, the product through one of its authorized service centers. All repairs for which warranty claims are made must be preauthorized by ICON. If the product is shipped to a service center, freight charges to and from the service center will be the customer's responsibility. For in-home service, the customer will be responsible for a minimal trip charge. This warranty does not extend to any product or damage to a product caused by or attributable to freight damage, abuse, misuse, improper or abnormal usage or repairs not provided by an ICON authorized service center; products used for commercial or rental purposes; or products used as store display models. No other warranty beyond that specifically set forth above is authorized by ICON.

ICON is not responsible or liable for indirect, special or consequential damages arising out of or in connection with the use or performance of the product or damages with respect to any economic loss, loss of property, loss of revenues or profits, loss of enjoyment or use, costs of removal or installation or other consequential damages of whatsoever nature. Some states do not allow the exclusion or limitation of incidental or consequential damages. Accordingly, the above limitation may not apply to you.

The warranty extended hereunder is in lieu of any and all other warranties and any implied warranties of merchantability or fitness for a particular purpose is limited in its scope and duration to the terms set forth herein. Some states do not allow limitations on how long an implied warranty lasts. Accordingly, the above limitation may not apply to you.

This warranty gives you specific legal rights. You may also have other rights which vary from state to state.

ICON HEALTH & FITNESS, INC., 1500 S. 1000 W., LOGAN, UT 84321-9813