

GOLD'S GYM®

XR 7.9

www.workoutwarehouse.com

Model No. GGBE6969.2

Serial No. _____

Write the serial number in the space above for reference.

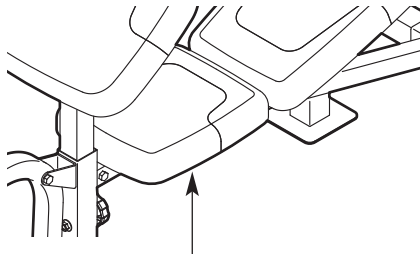

Serial Number Decal (under seat)

USER'S MANUAL

QUESTIONS?

If you have questions, or if parts are damaged or missing, **DO NOT CONTACT THE STORE**; please contact Customer Care.

IMPORTANT: Please register this product (see the limited warranty on the back cover of this manual) before contacting Customer Care.

CALL TOLL-FREE:

1-877-776-4777

Mon.–Fri. 6 a.m.–6 p.m. MT

Sat. 8 a.m.–4 p.m. MT

ON THE WEB:

www.workoutwarehouse.com

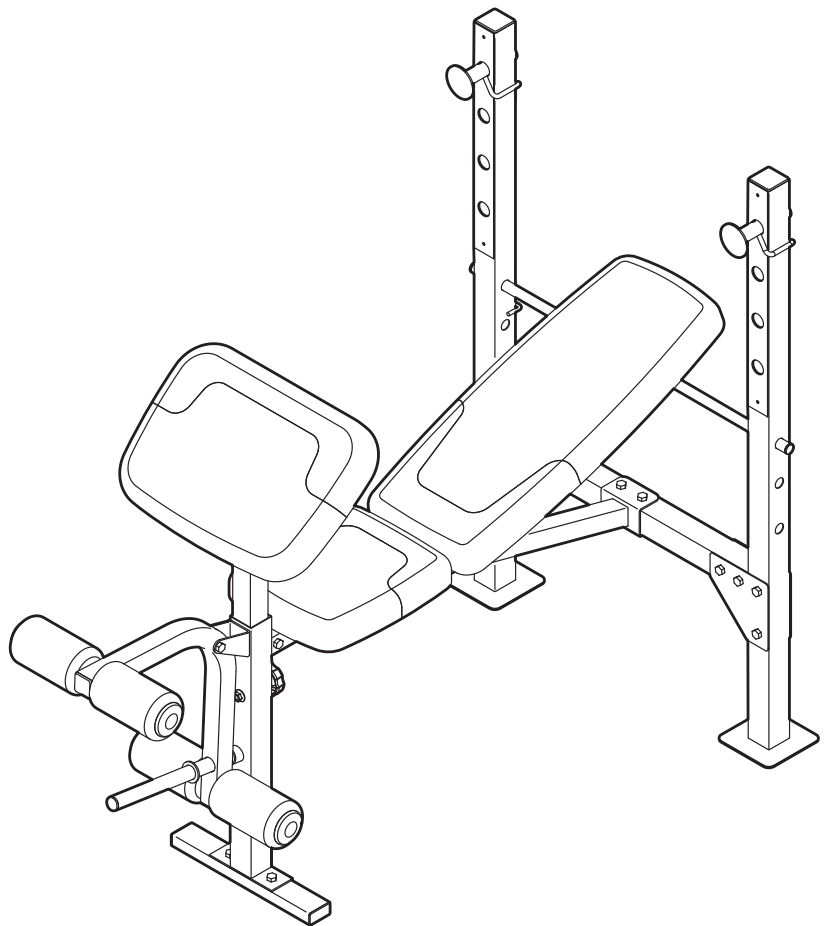

CAUTION

Read all precautions and instructions in this manual before using this equipment. Keep this manual for future reference.



TABLE OF CONTENTS

WARNING DECAL PLACEMENT2

IMPORTANT PRECAUTIONS3

BEFORE YOU BEGIN4

PART IDENTIFICATION CHART5

ASSEMBLY6

ADJUSTMENT11

EXERCISE GUIDELINES13

PART LIST14

EXPLODED DRAWING15

ORDERING REPLACEMENT PARTSBack Cover

LIMITED WARRANTYBack Cover

WARNING DECAL PLACEMENT

This drawing shows the location(s) of the warning decal(s). **If a decal is missing or illegible, see the front cover of this manual and request a free replacement decal. Apply the decal in the location shown.** Note: The decal(s) may not be shown at actual size.

WARNING
Keep hands and fingers clear of this area.

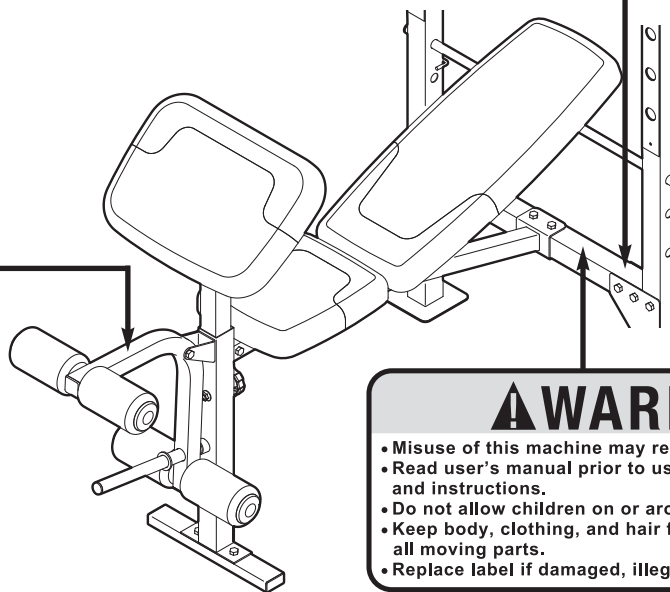

WARNING
User Weight: Max 250 LBS
Weight Crutch: Max 110 LBS
Leg Developer: Max 50 LBS
Weight Carriage: Max 110 LBS
Chest Fly Per Arm: Max 30 LBS
Product may not offer all listed exercises.

WARNING

- Misuse of this machine may result in serious injury.
- Read user's manual prior to use and follow all warnings and instructions.
- Do not allow children on or around machine.
- Keep body, clothing, and hair free and clear of all moving parts.
- Replace label if damaged, illegible, or removed.

IMPORTANT PRECAUTIONS

⚠ WARNING: To reduce the risk of serious injury, read all important precautions and instructions in this manual and all warnings on your weight bench before using your weight bench. ICON assumes no responsibility for personal injury or property damage sustained by or through the use of this product.

1. Before beginning any exercise program, consult your physician. This is especially important for persons over age 35 or persons with pre-existing health problems.
2. Read all instructions in this manual and all warnings on the weight bench before using the weight bench.
3. It is the responsibility of the owner to ensure that all users of the weight bench are adequately informed of all precautions.
4. The weight bench is intended for home use only. Do not use the weight bench in any commercial, rental, or institutional setting.
5. Keep the weight bench indoors, away from moisture and dust. Place the weight bench on a level surface, with a mat beneath it to protect the floor or carpet. Make sure that there is enough clearance around the weight bench to mount, dismount, and use the weight bench.
6. Keep children under age 12 and pets away from the weight bench at all times.
7. Inspect and properly tighten all parts regularly. Replace any worn parts immediately.
8. Keep hands and feet away from moving parts.
9. Always wear athletic shoes for foot protection while using the weight bench.
10. Do not use a barbell that is longer than 6 ft. (1.8 m) with the weight bench. Note: The weight bench does not include a barbell or weights.
11. The weight bench is designed to support a maximum user weight of 250 lbs. (113 kg) and a maximum total weight of 360 lbs. (163 kg). Do not place more than 110 lbs. (50 kg), including a barbell and weights, on the weight rests. Do not place more than 50 lbs. (23 kg) on the leg lever.
12. Always make sure that there is an equal amount of weight on each side of your barbell while you are using it. Always keep some weight on both ends of the barbell while adding or removing weights to prevent the barbell from tipping.
13. When you are using the leg lever, place a barbell with the same amount of weight on the weight rests to balance the weight bench.
14. Always exercise with a partner. When you are performing bench press exercises, your partner should stand behind you to catch the barbell if you cannot complete a repetition.
15. When using the backrest in the level position or an inclined position, make sure that the backrest support is inserted completely through both uprights, and that the backrest support is turned to the locked position.
16. Over exercising may result in serious injury or death. If you feel faint or if you experience pain while exercising, stop immediately and cool down.

BEFORE YOU BEGIN

Thank you for selecting the new GOLD'S GYM® XR 7.9 weight bench. The XR 7.9 weight bench offers a selection of exercises designed to develop the major muscle groups of the body. Whether your goal is to tone your body, build dramatic muscle size and strength, or improve your cardiovascular system, the weight bench will help you to achieve the specific results you want.

For your benefit, read this manual carefully before using the weight bench. If you have questions after

reading this manual, please see the front cover of this manual. To help us assist you, note the product model number and serial number before contacting us. The model number and the location of the serial number decal are shown on the front cover of this manual.

Before reading further, please look at the drawing below and familiarize yourself with the parts that are labeled.

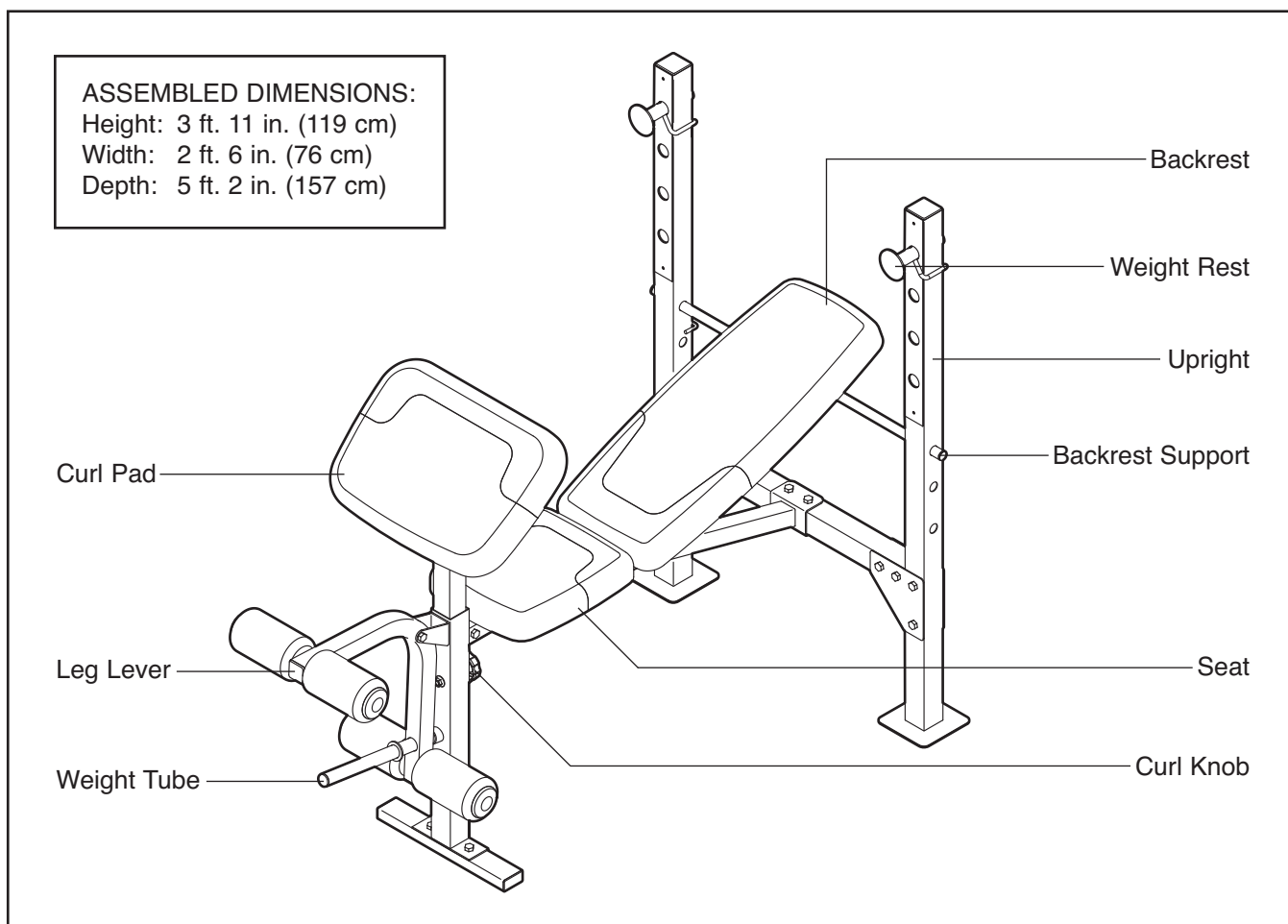

PART IDENTIFICATION CHART

Refer to the drawings below to identify small parts used in assembly. The number in parentheses by each drawing is the key number of the part, from the PART LIST near the end of this manual. **IMPORTANT: If you cannot find a part in the hardware kit, check to see if it has been preassembled. To avoid damaging plastic parts, do not use power tools for assembly.**

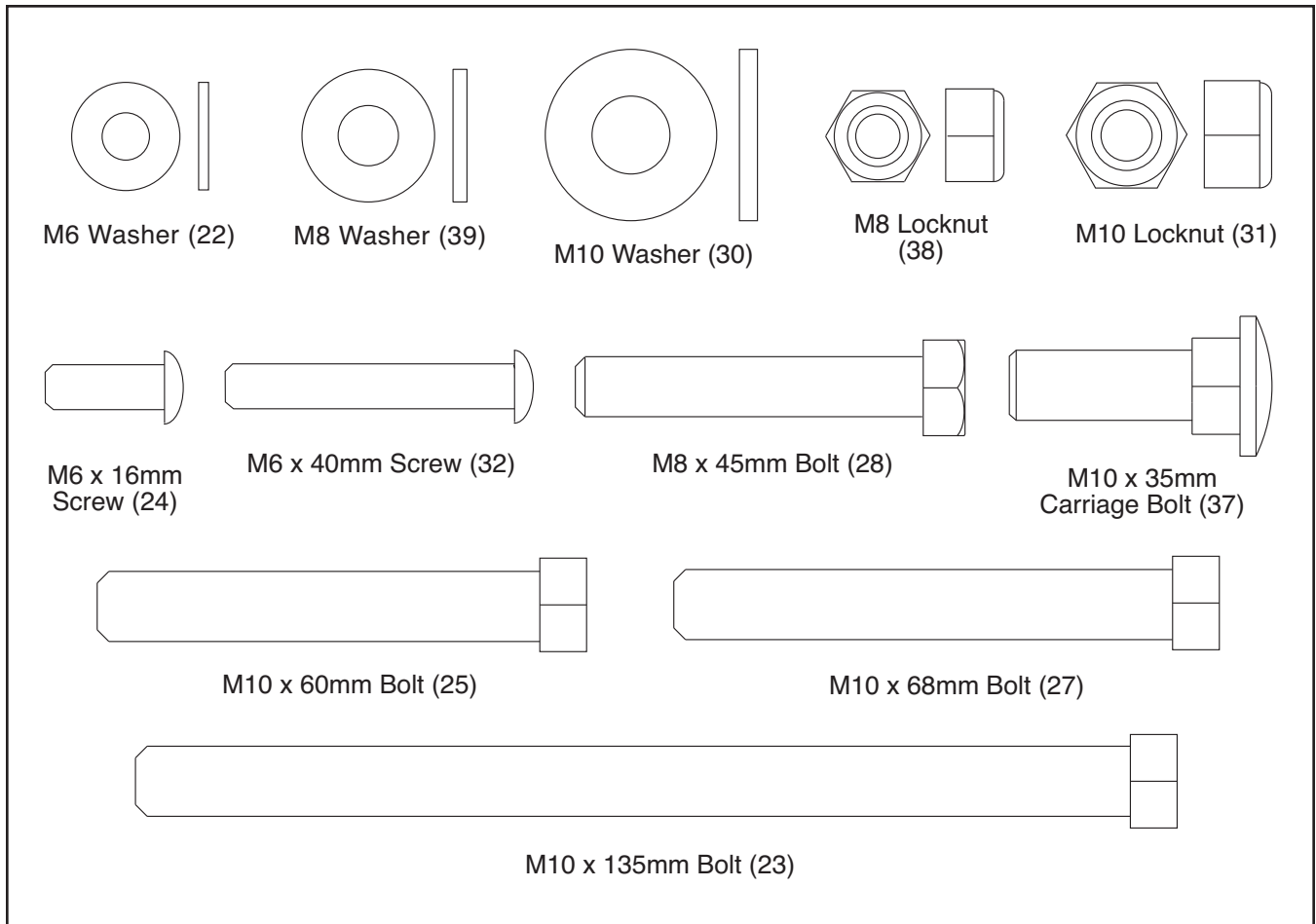

ASSEMBLY

- To hire an authorized service technician to assemble the weight bench in your home, call 1-800-445-2480.
- Assembly requires two persons.
- Because of its size and weight, assemble the weight bench in the location where it will be used. Make sure that there is enough clearance to walk around the weight bench as you assemble it.
- Place all parts in a cleared area and remove the packing materials. Do not dispose of the packing materials until you complete all assembly steps.

- To identify small parts, see page 5.
- The following tools (not included) may be required for assembly:

two adjustable wrenches



one rubber mallet



one standard screwdriver

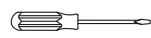

one Phillips screwdriver



Assembly will be more convenient if you have a socket set, a set of open-end or closed-end wrenches, or a set of ratchet wrenches.

1.

To make assembly easier, make sure that you have read the assembly tips in the box above.

Orient one of the Uprights (1) so that the Upright Cover (10) is on the side shown. Next, orient two Joint Plates (35) as shown. Attach the Joint Plates to the Upright with two M10 x 68mm Bolts (27) and two M10 Locknuts (31). Do not tighten the Locknuts yet.

Repeat this step with the other Upright (1) and the other Joint Plates (35), making sure that they are oriented as shown.

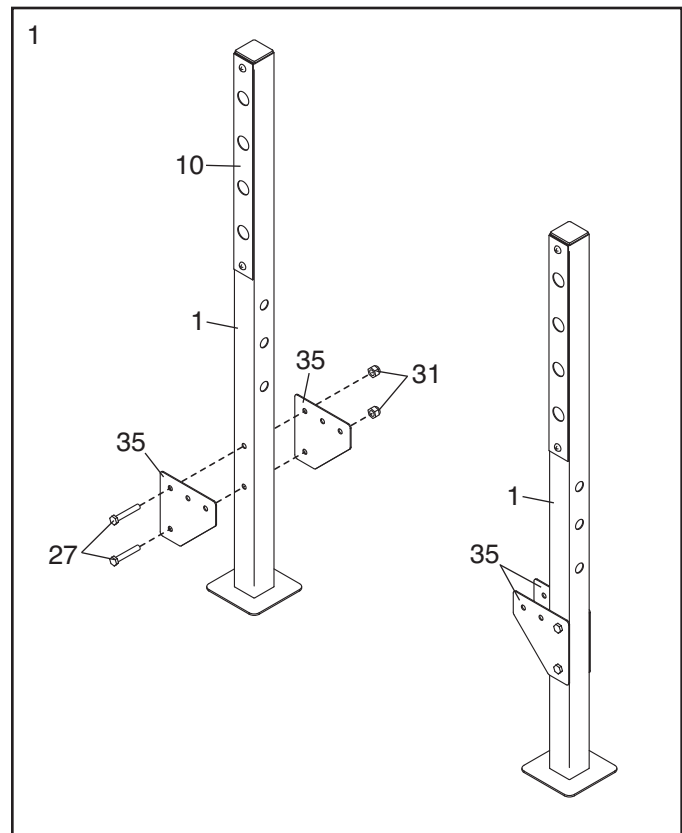

2. Orient the Crossbar (2) so that the warning decals are in the position shown.

Attach one end of the Crossbar (2) to two Joint Plates (35) with two M10 x 68mm Bolts (27) and two M10 Locknuts (31). **Do not tighten the Locknuts yet.**

Attach the other end of the Crossbar (2) in the same way.

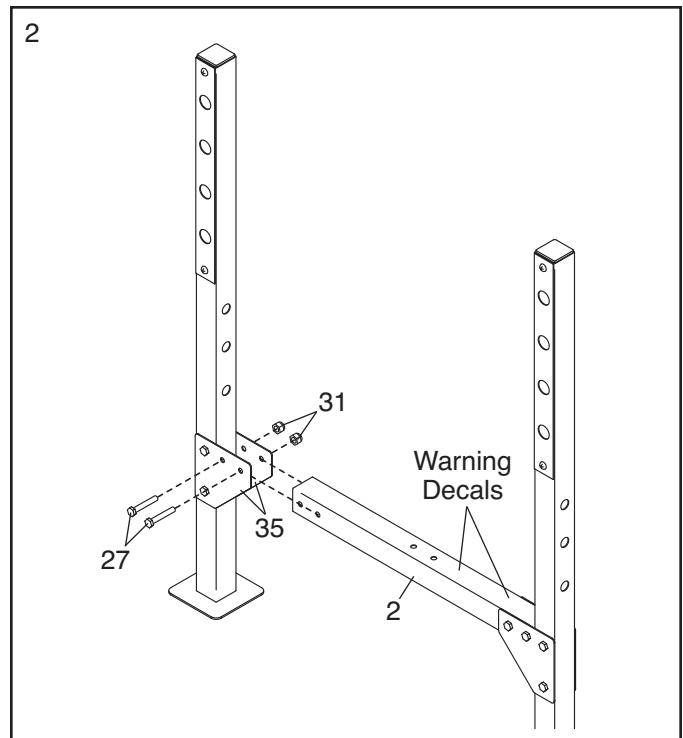

3. Orient the Base (33) so that the square holes are facing the floor.

Attach the Base (33) to the Front Leg (4) with two M10 x 35mm Carriage Bolts (37) and two M10 Locknuts (31).

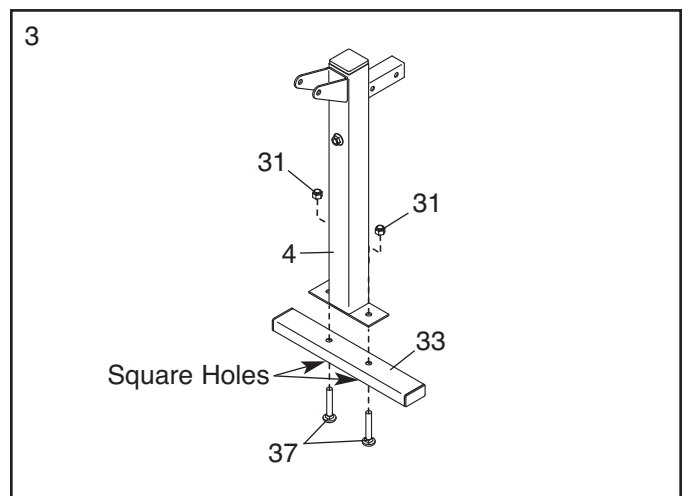

4. Attach the Front Leg (4) to the Frame (3) with two M8 x 45mm Bolts (28), two M8 Washers (39), and two M8 Locknuts (38). **Make sure that the Locknuts are in the indicated hexagonal holes; do not tighten the Bolts yet.**

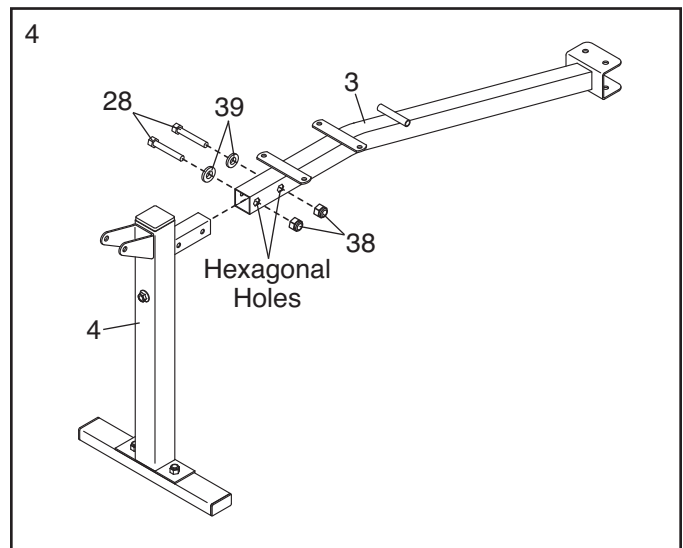

5. Attach the Frame (3) to the Crossbar (2) with two M10 x 68mm Bolts (27) and two M10 Locknuts (31). **Do not tighten the Locknuts yet.**

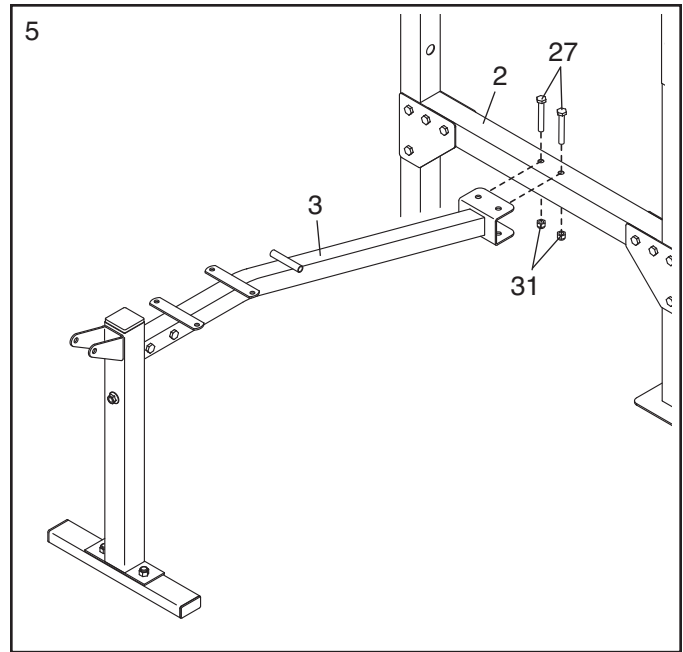

6. Insert the Backrest Support (14) into one of the three sets of holes in the Uprights (1). **Rotate the Backrest Support so that the locking pin is wrapped around the Upright (see the inset drawing).**

See steps 1, 2, 4, and 5. Tighten the M10 Locknuts (31) and the M8 Locknuts (38) used in these steps.

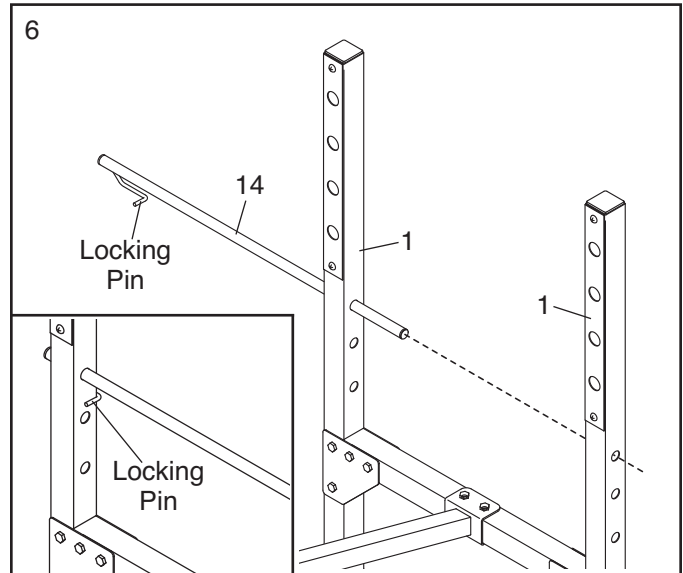

7. Apply part of the included grease packet to an M10 x 60mm Bolt (25).

Attach the Leg Lever (6) to the Front Leg (4) with the M10 x 60mm Bolt (25) and an M10 Locknut (31). **Do not overtighten the Locknut; the Leg Lever must pivot easily.**

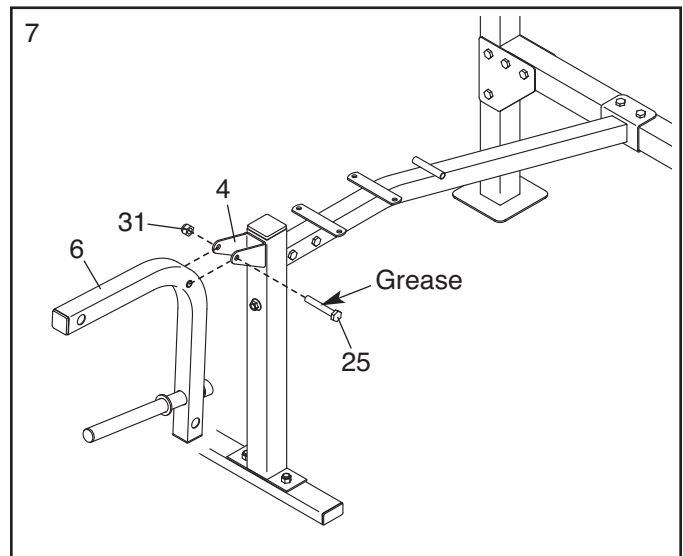

8. Insert a Pad Tube (12) through the Leg Lever (6). Slide a Foam Pad (13) onto each end of the Pad Tube. Then, press a Pad Cap (34) into each end of the Pad Tube.

Repeat this step with the other Pad Tube (12), Foam Pads (13), and Pad Caps (34).

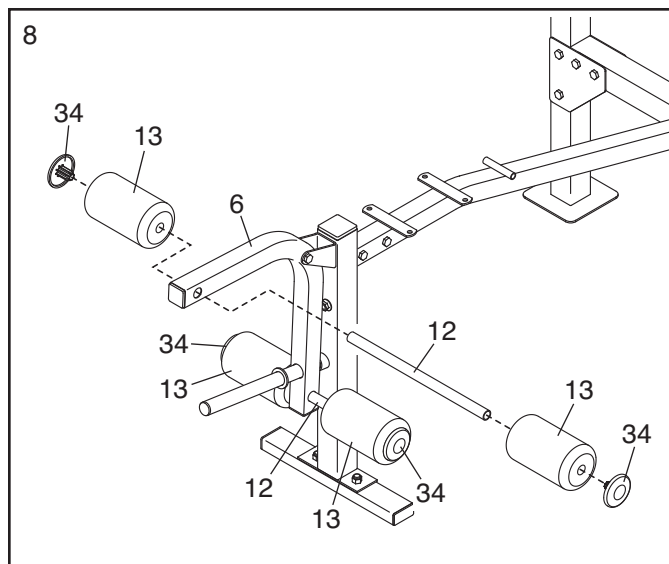

9. Insert a Weight Rest (15) into an Upright (1). Rotate the Weight Rest so that the locking pin is wrapped around the Upright.

Repeat this step with the other Weight Rest (15). Make sure that the Weight Rests are at the same height.

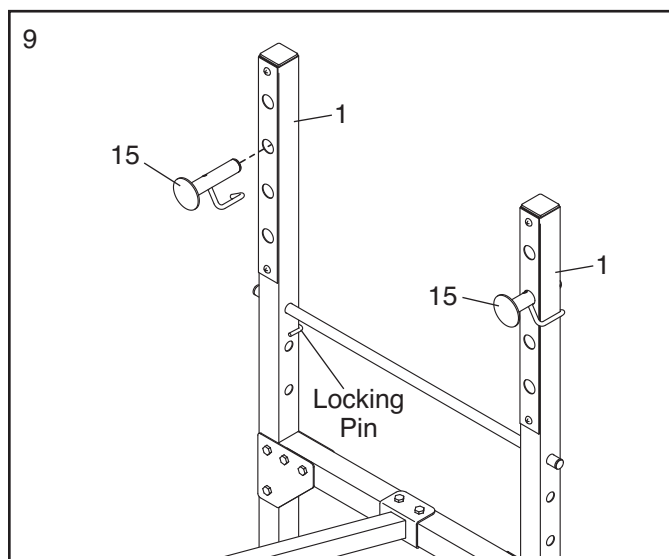

10. Orient the Backrest (8) as shown.

Orient the Backrest Tubes (7) so that the indicated holes are in the position shown.

Attach the Backrest Tubes (7) to the Backrest (8) with four M6 x 40mm Screws (32) and four M6 Washers (22). **Do not tighten the Screws yet.**

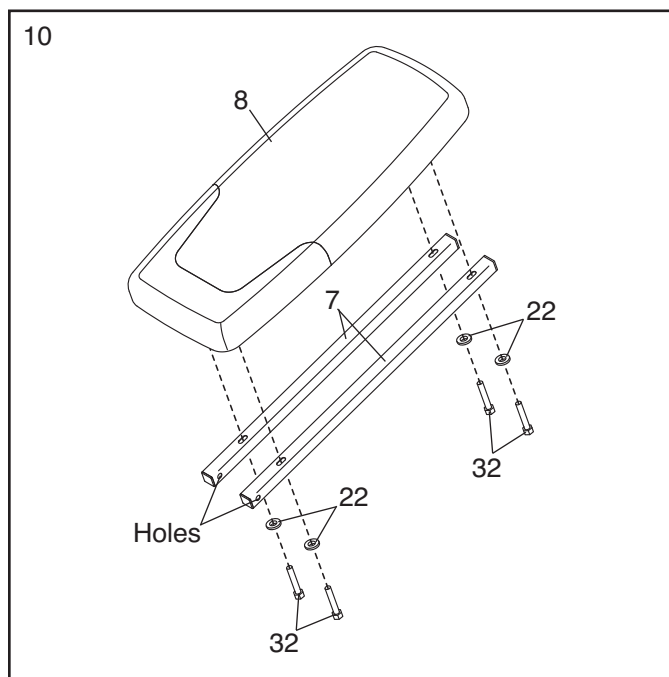

11. Apply grease to an M10 x 135mm Bolt (23).

Attach the Backrest Tubes (7) to the welded tube on the Frame (3) with the M10 x 135mm Bolt (23), two M10 Washers (30), and an M10 Locknut (31). **Do not overtighten the Locknut; the Backrest Tubes must pivot easily.**

See step 10. Tighten the M6 x 40mm Screws (32).

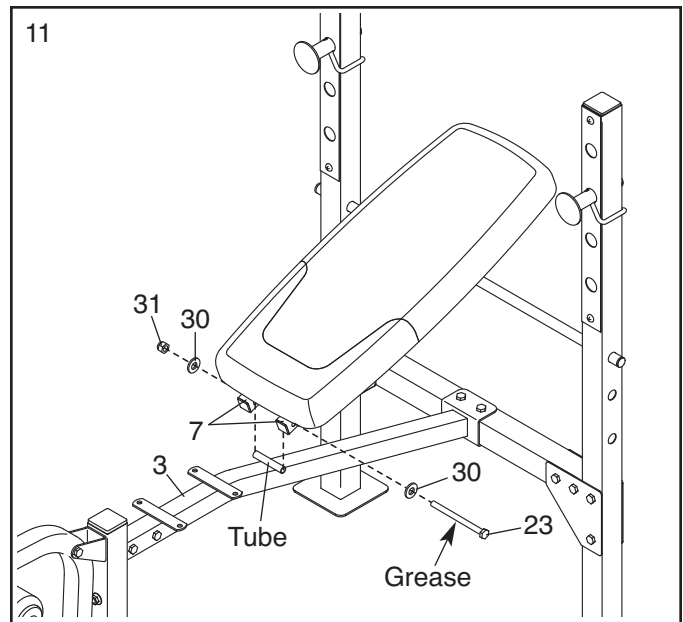

12. Orient the Seat (9) as shown.

Attach the Seat (9) to the Frame (3) with four M6 x 16mm Screws (24).

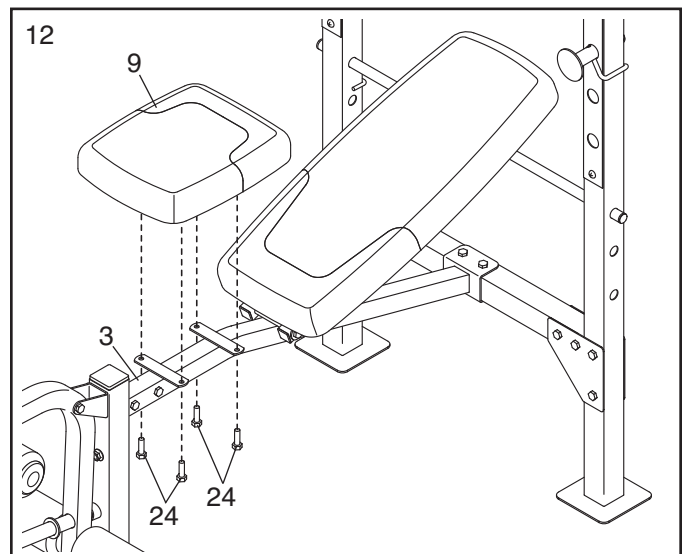

13. Orient the Curl Pad (5) as shown.

Attach the Curl Pad (5) to the Curl Post (11) with four M6 x 16mm Screws (24).

14. **Make sure that all parts are properly tightened before you use the weight bench.** The use of all remaining parts will be explained in ADJUSTMENT, beginning on page 11.

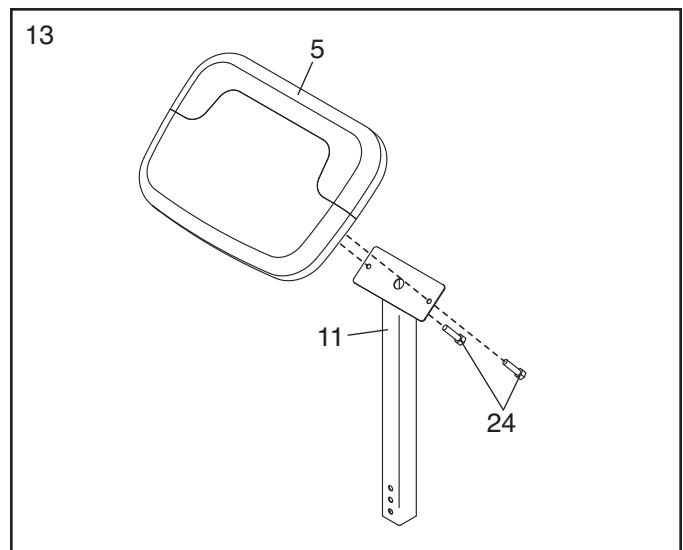

ADJUSTMENT

The weight bench is designed to be used with your own weight set (not included). The steps below explain how the weight bench can be adjusted. See EXERCISE GUIDELINES on page 13 for important exercise information, and refer to the accompanying exercise guide to see the correct form for several exercises. Refer also to the exercise information accompanying your weight set for additional exercises.

Make sure that all parts are properly tightened each time the weight bench is used. Replace any worn parts immediately. The weight bench can be cleaned with a damp cloth and a mild, non-abrasive detergent; **do not use solvents to clean the weight bench.**

ADJUSTING THE BACKREST

The Backrest (8) can be used in a declined position, a level position, or either of two inclined positions. To use the Backrest in the declined position, remove the Backrest Support (14) and lay the Backrest on the Crossbar (2).

To use the Backrest (8) in the level position or an inclined position, lift the Backrest and insert the Backrest Support (14) through one of the sets of holes in the Uprights (1). **Rotate the Backrest Support so that the locking pin is wrapped around the right Upright.**

⚠ WARNING: When using the Backrest (8) in a level position or an inclined position, insert the Backrest Support (14) completely into both Uprights (1) and turn it to the locked position.

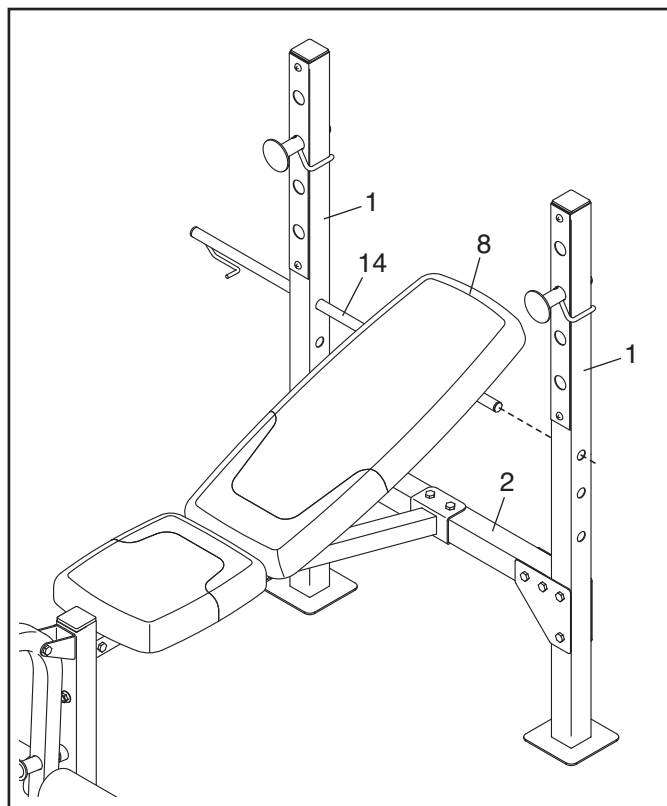

ATTACHING WEIGHTS TO THE LEG LEVER

To use the Leg Lever (6), slide the desired weights (not included) onto the weight tube.

⚠ WARNING: Do not place more than 50 lbs. (23 kg) on the Leg Lever (6).

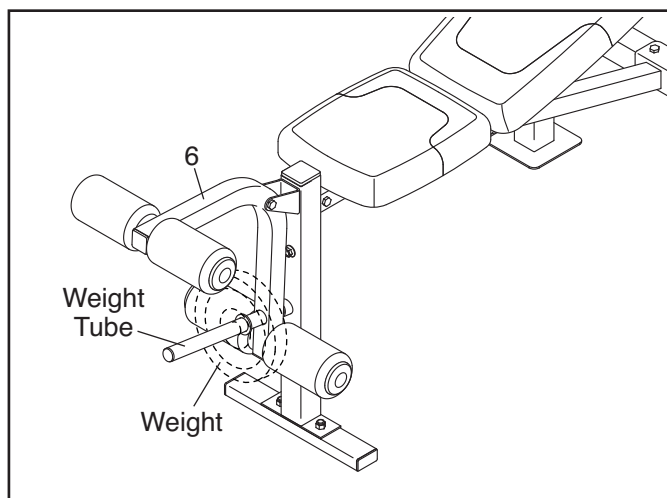

ADJUSTING THE WEIGHT RESTS

To change the height of the Weight Rests (15), remove them from the Uprights (1) and insert them into a different set of holes in the Uprights. **Rotate the Weight Rests so that the locking pins are wrapped around the Uprights.**

⚠ WARNING: Always rotate the Weight Rests (15) so that the locking pins are wrapped around the Uprights (1). Always set both Weight Rests at the same height.

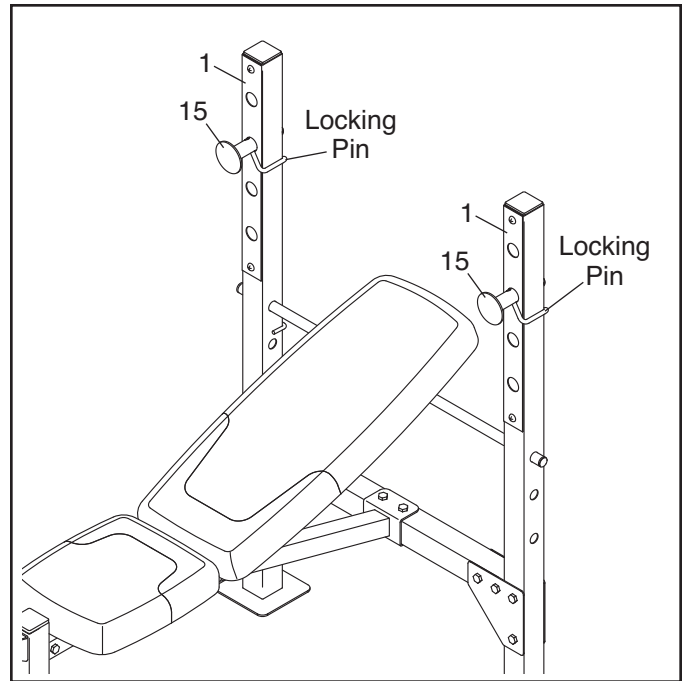

USING THE CURL PAD

To use the Curl Pad (5), first remove the 50mm Square Inner Cap (16) from the Front Leg (4).

Next, insert the Curl Post (11) into the Front Leg (4), and tighten the Curl Knob (36) into the Front Leg and into one of the adjustment holes in the Curl Post. **Make sure that the Curl Knob is in one of the holes in the Curl Post.**

Note: When you are not using the Curl Pad (5), remove the Curl Post (11) and insert the 50mm Square Inner Cap (16) into the Front Leg (4).

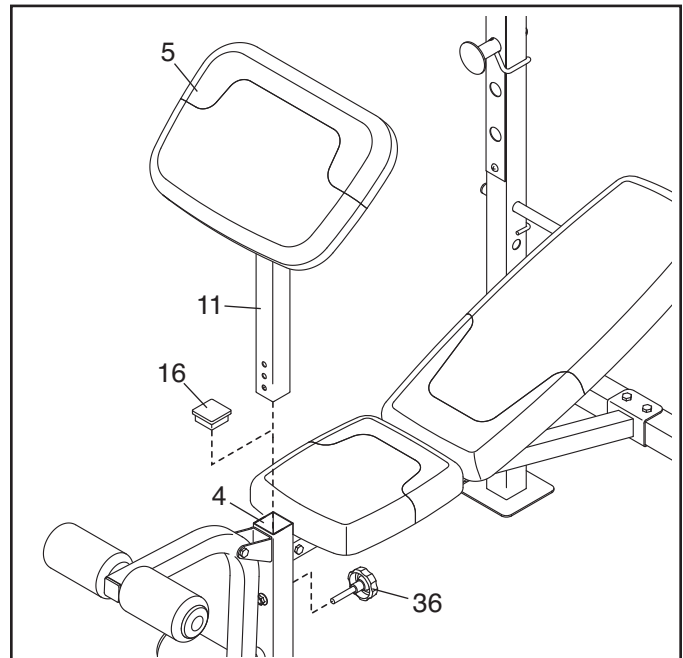

EXERCISE GUIDELINES

FOUR TYPES OF STRENGTH WORKOUTS

Note: A “repetition” is one complete cycle of an exercise, such as one sit-up. A “set” is a series of repetitions.

Muscle Building—Work your muscles near their maximum capacity and progressively increase the intensity of your exercise. Adjust the intensity level of an individual exercise as follows:

- Change the amount of resistance used.
- Change the number of repetitions or sets performed.

Use your own judgment to determine the amount of resistance that is right for you. Begin with 3 sets of 8 repetitions for each exercise you perform. Rest for 3 minutes after each set. When you can complete 3 sets of 12 repetitions without difficulty, increase the amount of resistance.

Toning—Tone your muscles by working them to a moderate percentage of their capacity. Select a moderate amount of resistance and increase the number of repetitions in each set. Complete as many sets of 15 to 20 repetitions as possible without discomfort. Rest for 1 minute after each set. Work your muscles by completing more sets rather than by using high amounts of resistance.

Weight Loss—To lose weight, use a low amount of resistance and increase the number of repetitions in each set. Exercise for 20 to 30 minutes, resting for a maximum of 30 seconds between sets.

Cross Training—Combine strength training and aerobic exercise by following this type of program:

- Strength workouts on Monday, Wednesday, and Friday.
- 20 to 30 minutes of aerobic exercise on Tuesday and Thursday.
- One full day of rest each week to give your body time to regenerate.

WORKOUT GUIDELINES

Familiarize yourself with the equipment and learn the proper form for each exercise. Use your own judgment to determine the appropriate length of time for each

workout, and the numbers of repetitions and sets to complete. Progress at your own pace and be sensitive to your body’s signals. Follow each strength workout with at least one day of rest.

Warming Up—Start with 5 to 10 minutes of stretching and light exercise. A warm-up increases your body temperature, heart rate, and circulation in preparation for exercise.

Working Out—Include 6 to 10 different exercises in each workout. Select exercises for every major muscle group, emphasizing areas that you want to develop. To give balance and variety to your workouts, vary the exercises from workout to workout.

Cooling Down—Finish with 5 to 10 minutes of stretching. Stretching increases the flexibility of your muscles and helps to prevent post-exercise problems.

EXERCISE FORM

Move through the full range of motion for each exercise and move only the appropriate parts of the body. Perform the repetitions in each set smoothly and without pausing. The exertion stage of each repetition should last about half as long as the return stage. Exhale during the exertion stage of each repetition and inhale during the return stroke. Never hold your breath.

Rest for a short period of time after each set:

- Muscle Building—Rest for three minutes after each set.
- Toning—Rest for one minute after each set.
- Weight Loss—Rest for 30 seconds after each set.

STAYING MOTIVATED

For motivation, keep a record of each workout. Write the date, the exercises performed, the resistance used, and the numbers of sets and repetitions completed. Record your weight and key body measurements once a month. To achieve good results, make exercise a regular and enjoyable part of your life.

PART LIST—Model No. GGBE6969.2

R0710A

Key No.	Qty.	Description	Key No.	Qty.	Description
1	2	Upright	23	1	M10 x 135mm Bolt
2	1	Crossbar	24	6	M6 x 16mm Screw
3	1	Frame	25	1	M10 x 60mm Bolt
4	1	Front Leg	26	2	25mm x 50mm Inner Cap
5	1	Curl Pad	27	10	M10 x 68mm Bolt
6	1	Leg Lever	28	2	M8 x 45mm Bolt
7	2	Backrest Tube	29	4	M4 x 16mm Screw
8	1	Backrest	30	2	M10 Washer
9	1	Seat	31	14	M10 Locknut
10	2	Upright Cover	32	4	M6 x 40mm Screw
11	1	Curl Post	33	1	Base
12	2	Pad Tube	34	4	Pad Cap
13	4	Foam Pad	35	4	Joint Plate
14	1	Backrest Support	36	1	Curl Knob
15	2	Weight Rest	37	2	M10 x 35mm Carriage Bolt
16	3	50mm Square Inner Cap	38	2	M8 Locknut
17	1	25mm Round Angled Cap	39	2	M8 Washer
18	2	38mm Square Inner Cap	40	1	25mm x 2mm Round Inner Cap
19	4	25mm Square Inner Cap	*	—	User's Manual
20	2	25mm x 2.5mm Round Inner Cap	*	—	Exercise Guide
21	2	21mm Round Inner Cap	*	—	Grease Packet
22	4	M6 Washer			

Note: Specifications are subject to change without notice. For information about ordering replacement parts, see the back cover of this manual. *These parts are not illustrated.

EXPLODED DRAWING—Model No. GGBE6969.2

R0710A

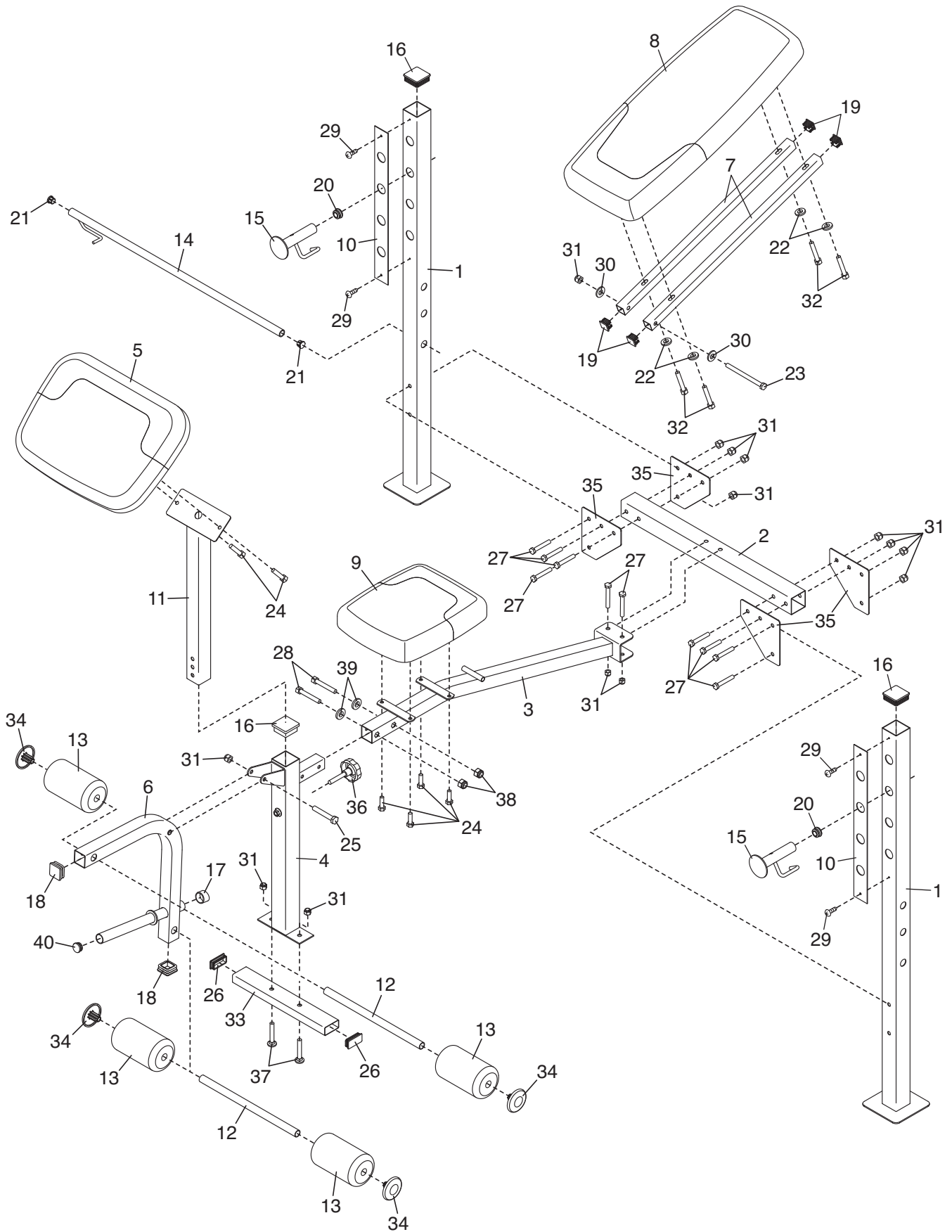

ORDERING REPLACEMENT PARTS

To order replacement parts, please see the front cover of this manual. To help us assist you, be prepared to provide the following information when contacting us:

- the model number and serial number of the product (see the front cover of this manual)
- the name of the product (see the front cover of this manual)
- the key number and description of the replacement part(s) (see the PART LIST and the EXPLODED DRAWING near the end of this manual)

LIMITED WARRANTY

IMPORTANT: You must register this product within 30 days of the purchase date to avoid added fees for service needed under warranty. Go to www.workoutwarehouse.com/registration.

ICON Health & Fitness, Inc. (ICON) warrants this product to be free from defects in workmanship and material, under normal use and service conditions, for a period of ninety (90) days from the date of purchase.

This warranty extends only to the original purchaser. ICON's obligation under this warranty is limited to repairing or replacing, at ICON's option, the product through one of its authorized service centers. All repairs for which warranty claims are made must be preauthorized by ICON. If the product is shipped to a service center, freight charges to and from the service center will be the customer's responsibility. For replacement parts shipped while the product is under warranty, the customer will be responsible for a minimal handling charge. For in-home service, the customer will be responsible for a minimal trip charge. This warranty does not extend to any damage to a product caused by or attributable to freight damage, abuse, misuse, improper or abnormal usage, or repairs not provided by an ICON authorized service center; to products used for commercial or rental purposes or as store display models; or to products transported or purchased outside the US. No other warranty beyond that specifically set forth above is authorized by ICON.

ICON is not responsible or liable for indirect, special, or consequential damages arising out of or in connection with the use or performance of the product; damages with respect to any economic loss, loss of property, loss of revenues or profits, loss of enjoyment or use, or costs of removal or installation; or other consequential damages of whatsoever nature. Some states do not allow the exclusion or limitation of incidental or consequential damages. Accordingly, the above limitation may not apply to you.

The warranty extended hereunder is in lieu of any and all other warranties, and any implied warranties of merchantability or fitness for a particular purpose are limited in their scope and duration to the terms set forth herein. Some states do not allow limitations on how long an implied warranty lasts. Accordingly, the above limitation may not apply to you.

This warranty gives you specific legal rights. You may also have other rights that vary from state to state.

ICON Health & Fitness, Inc., 1500 S. 1000 W., Logan, UT 84321-9813