

GOLD'S GYM®

GS 2700

POWERGLIDE

Model No. GGSY3066.0

Serial No. _____

Write the serial number in the space above for future reference.

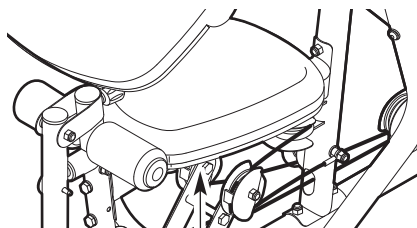

Serial Number Decal (under seat)

QUESTIONS?

As a manufacturer, we are committed to providing complete customer satisfaction. If you have questions, or if a part is damaged or missing, PLEASE CONTACT OUR CUSTOMER SERVICE DEPARTMENT DIRECTLY.

CALL TOLL-FREE:

1-877-776-4777

Mon.–Fri., 6 a.m.–6 p.m. MST

ON THE WEB:

www.goldsgympowerflex.com

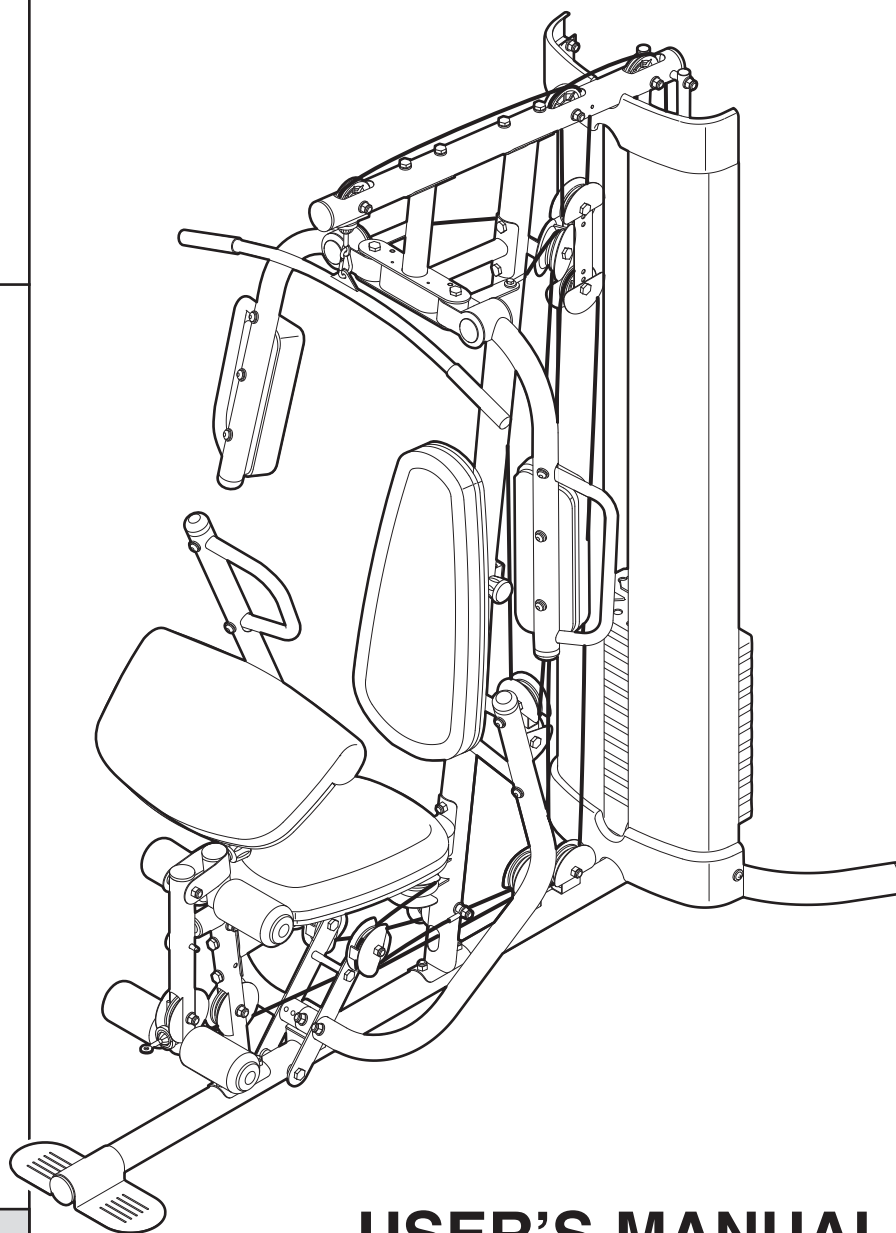

⚠ CAUTION

Read all precautions and instructions in this manual before using this equipment. Save this manual for future reference.

USER'S MANUAL

TABLE OF CONTENTS

IMPORTANT PRECAUTIONS	3
BEFORE YOU BEGIN	4
PART IDENTIFICATION CHART	5
ASSEMBLY	8
ADJUSTMENTS	25
WEIGHT RESISTANCE CHART	27
CABLE DIAGRAM	28
MAINTENANCE	29
EXERCISE GUIDELINES	30
PART LIST	33
EXPLODED DRAWING	34
ORDERING REPLACEMENT PARTS	Back Cover
LIMITED WARRANTY	Back Cover

GOLD'S GYM is a registered trademark of Gold's Gym International, Inc. This product is manufactured and distributed under license from Gold's Gym International, Inc.

IMPORTANT PRECAUTIONS

⚠️WARNING: To reduce the risk of serious injury, read the following important precautions before using the weight system.

1. Read all instructions in this manual and all warnings on the weight system before using the weight system. Use the weight system only as described in this manual.
2. It is the responsibility of the owner to ensure that all users of the weight system are adequately informed of all precautions.
3. The weight system is intended for home use only. Do not use the weight system in any commercial, rental, or institutional setting.
4. Keep the weight system indoors, away from moisture and dust. Place the weight system on a level surface, with a mat beneath it to protect the floor or carpet. Make sure that there is enough clearance around the weight system to mount, dismount, and use the weight system.
5. Inspect and properly tighten all parts regularly. Replace any worn parts immediately.
6. Keep hands and feet away from moving parts.
7. Keep children under 12 and pets away from the weight system at all times.
8. Always wear athletic shoes for foot protection while exercising.
9. Make sure that the cable remains on the pulleys at all times. If the cable binds as you are exercising, stop immediately and make sure that the cable is on the pulleys. Replace all cables at least every two years.
10. The weight system is designed to be used only with the included weight. Do not use the weight system with dumbbells or any other type of weight to increase the resistance.
11. The weight system should not be used by persons weighing more than 300 pounds.
12. Always make sure that the weight pin is inserted fully into the weight stack before exercising.
13. If you feel pain or dizziness while exercising, stop immediately and cool down.
14. The decal shown below has been placed on the weight system. If the decal is missing or illegible, call the toll-free telephone number on the front cover of this manual and order a free replacement decal. Apply the decal in the location shown.

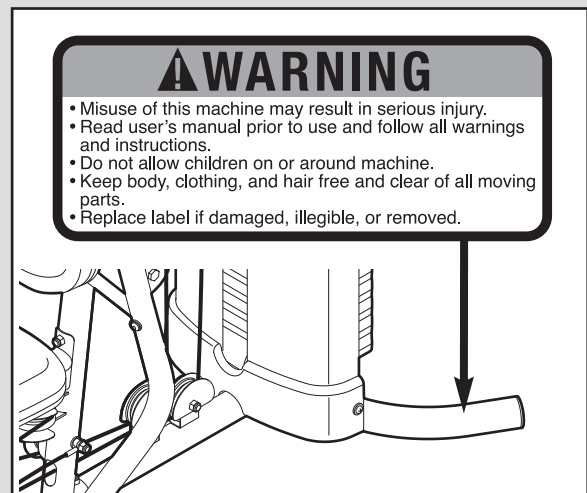

⚠️WARNING: Before beginning this or any exercise program, consult your physician. This is especially important for persons over the age of 35 or persons with pre-existing health problems. Read all instructions before using. ICON assumes no responsibility for personal injury or property damage sustained by or through the use of this product.

BEFORE YOU BEGIN

Thank you for selecting the versatile GOLD'S GYM® GS2700 POWERGLIDE weight system. The weight system offers a selection of exercise stations designed to develop the major muscle group of the upper body. Whether your goal is to tone your body, build dramatic muscle size and strength, or improve your cardiovascular system, the weight system will help you to achieve the specific results you want.

For your benefit, read this manual carefully before using the weight system. If you have questions after reading this manual, see the front cover of this manu-

al. To help us assist you, please note the product model number and serial number before calling. The model number is GGSY3066.0. The serial number can be found on a decal attached to the weight system (see the front cover of this manual for the location).

To avoid a registration fee for any service needed under warranty, you must register the weight system at www.iconservice.com/registration.

Before reading further, please review the drawing below and familiarize yourself with the parts that are labeled

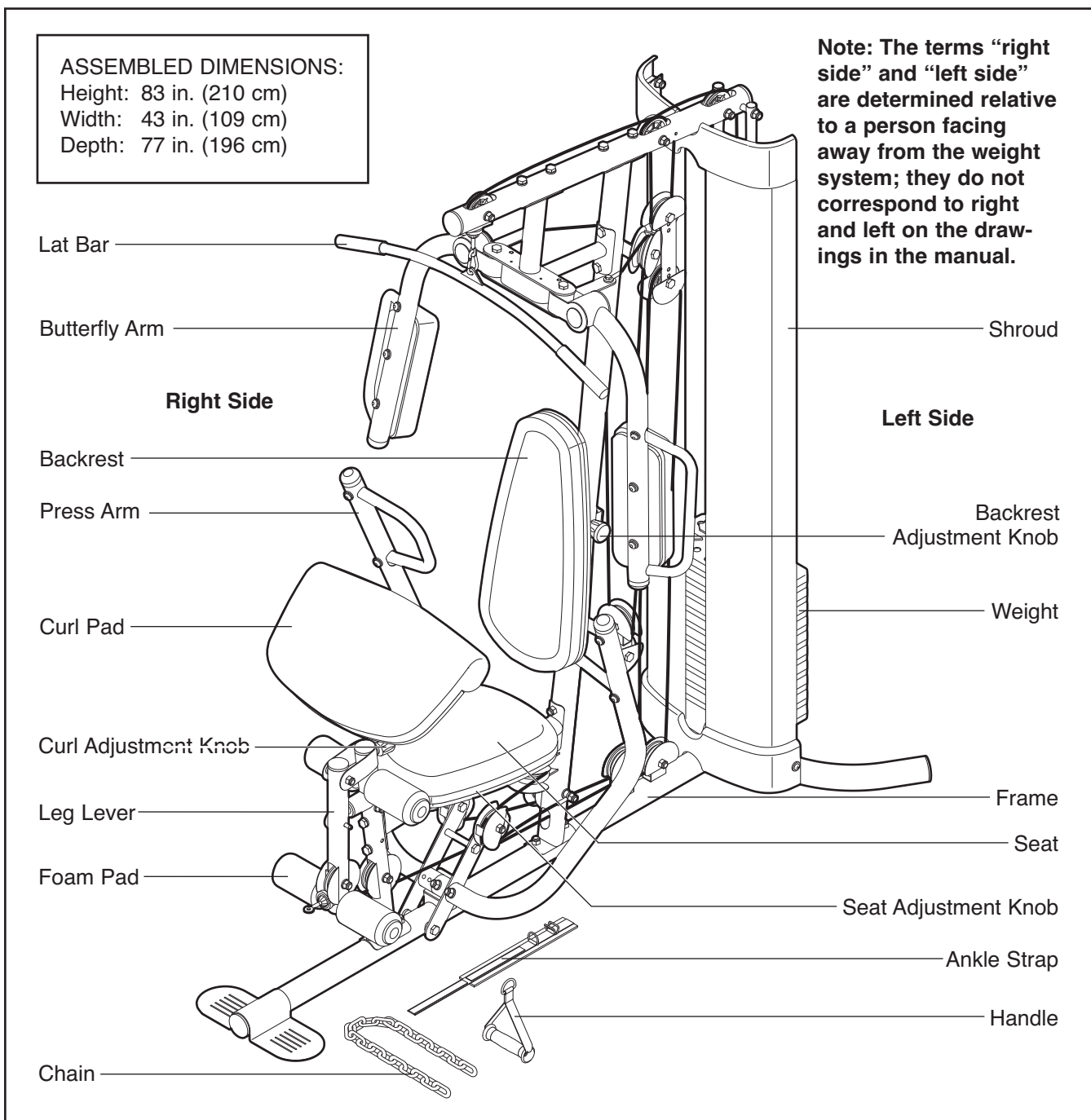

PART IDENTIFICATION CHART — Model No. GGSY3066.0

R1006A

Refer to the drawings below to identify small parts used in assembly. The number in parentheses by each drawing is the key number of the part, from the PART LIST in the center of this manual. **Note: Some small parts may have been preattached. If a part is not in the parts bag, check to see if it has been preattached. If a part is missing, call the toll-free telephone number on the front cover of this manual.**

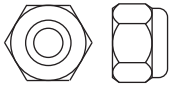

M6 Nylon
Locknut (107)

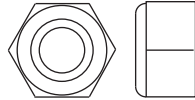

M8 Nylon
Locknut (78)

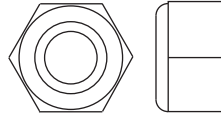

M10 Nylon
Locknut (77)

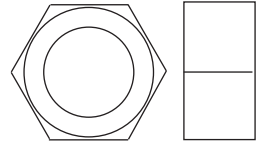

M12 Nut (112)



M4 Washer
(104)

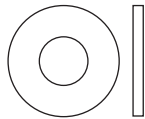

M6 Washer
(114)

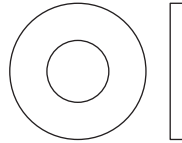

M8 Washer (103)

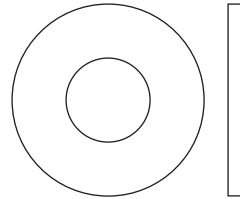

M10 Washer (80)

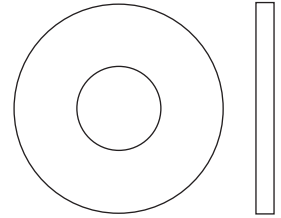

M10 Large Washer (105)

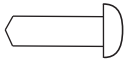

M4 x 12mm
Self-tapping
Screw (102)

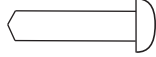

M4 x 16mm
Self-tapping
Screw (110)



M6 x 20mm
Screw (88)

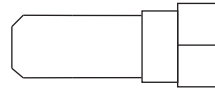

M8 x 22mm
Shoulder Bolt (90)

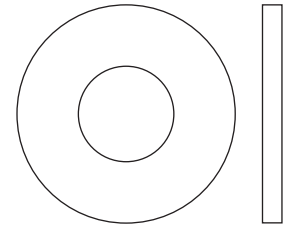

M12 Large Washer (98)

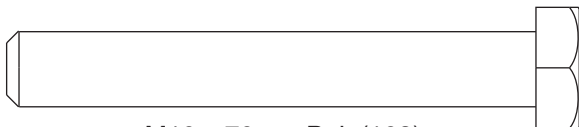

M10 x 70mm Bolt (108)

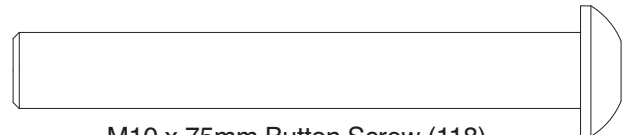

M10 x 75mm Button Screw (118)

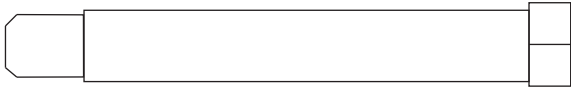

M8 x 69mm Shoulder Bolt (87)

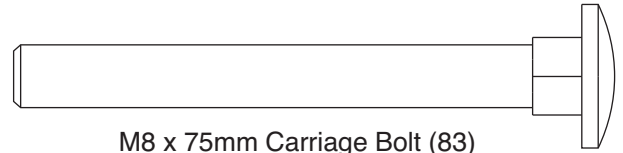

M8 x 75mm Carriage Bolt (83)

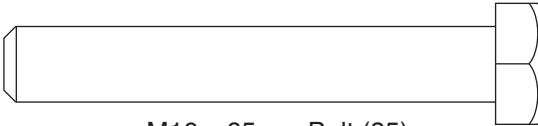

M10 x 65mm Bolt (85)

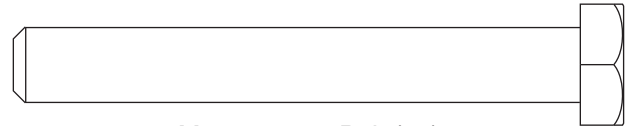

M10 x 75mm Bolt (82)

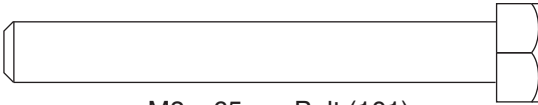

M8 x 65mm Bolt (101)

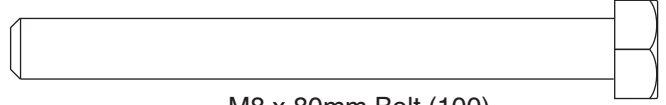

M8 x 80mm Bolt (100)

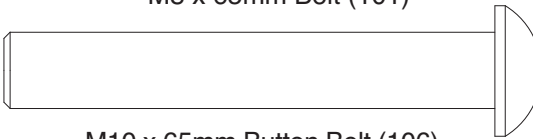

M10 x 65mm Button Bolt (106)

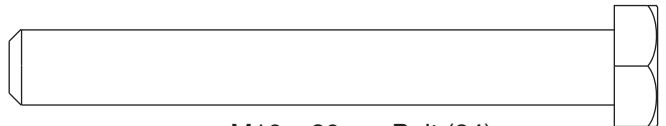

M10 x 80mm Bolt (84)



M6 x 65mm Button Screw (91)

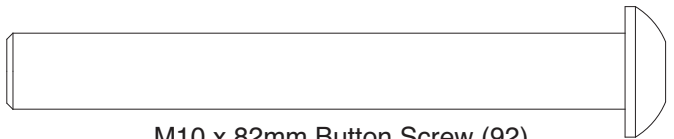

M10 x 82mm Button Screw (92)

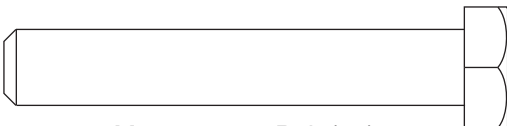

M10 x 60mm Bolt (79)

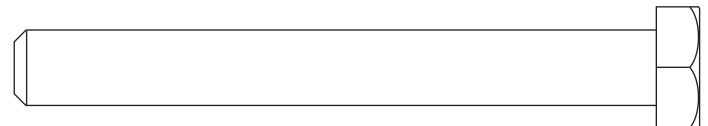

M10 x 85mm Bolt (81)

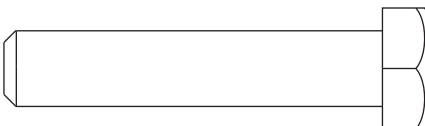

M10 x 50mm Bolt (97)



M10 x 61mm Bolt Set (116)

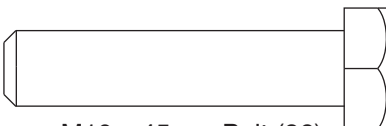

M10 x 45mm Bolt (86)

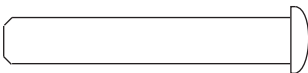

M6 x 38mm Screw (89)

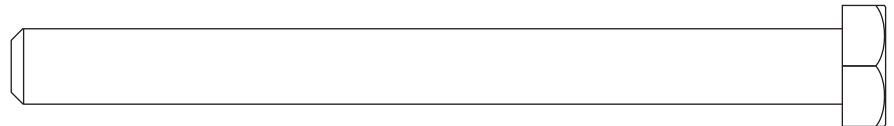

M10 x 110mm Bolt (93)

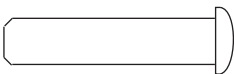

M6 x 28mm Bolt (94)

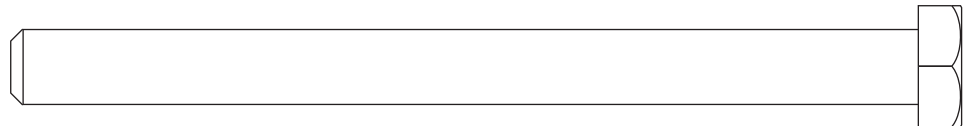

M10 x 120mm Bolt (115)

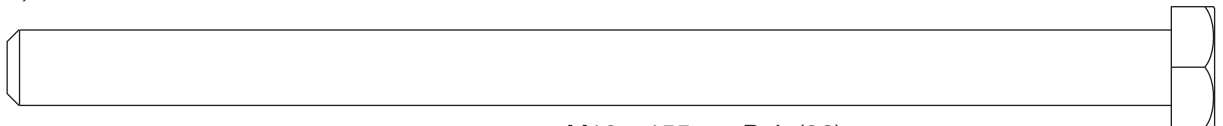

M10 x 155mm Bolt (96)

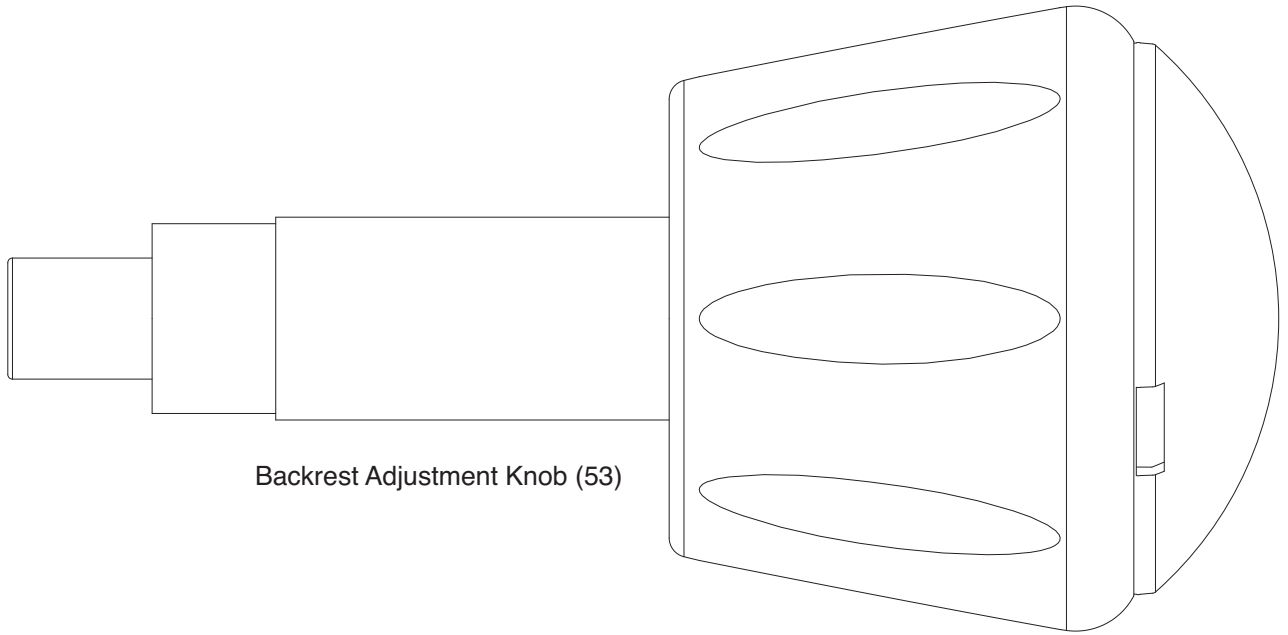

Backrest Adjustment Knob (53)

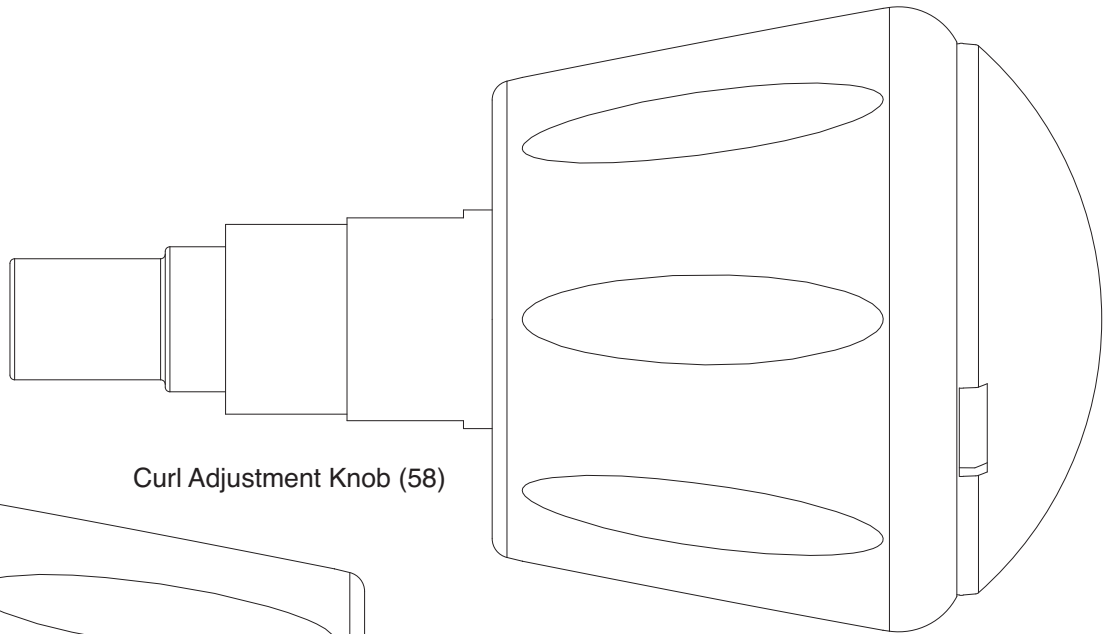

Curl Adjustment Knob (58)

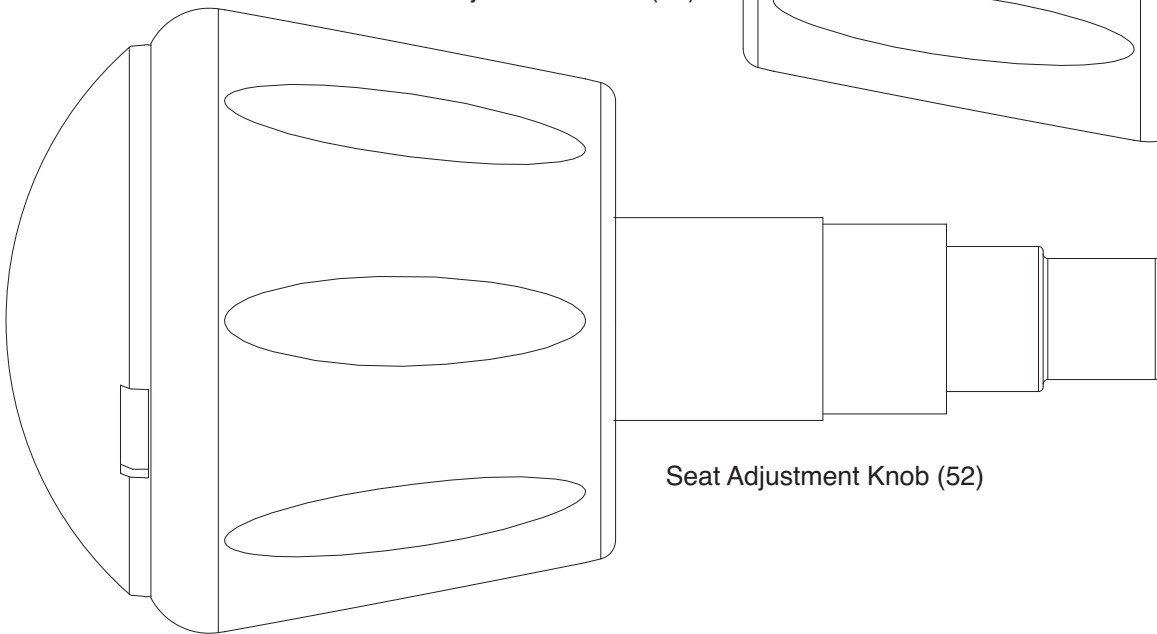

Seat Adjustment Knob (52)

ASSEMBLY

Make Assembly Easier

Everything in this manual is designed to ensure that the weight system can be assembled successfully by anyone. **Before beginning assembly, make sure to read the information on this page. This brief introduction will save you much more time than it takes to read it.**

Assembly Requires Two Persons

For your convenience and safety, assemble the weight system with the help of another person.

Set Aside Enough Time

Due to the many features of the weight system, the assembly process will require several hours. By setting aside plenty of time and by deciding to make the task enjoyable, assembly will go smoothly. You may want to assemble the weight system over a couple of evenings.





Select a Location for the Weight System

Because of its weight and size, the weight system should be assembled in the location where it will be used. Make sure that there is enough room to walk around the weight system as you assemble it.

How to Unpack the Box

To make assembly as easy as possible, we have divided the assembly process into four stages. The parts needed for each stage are found in individual bags. **Important: Wait until you begin each stage to open the parts bag for that stage.** Place all parts of the weight system in a cleared area and remove the packing materials. Do not dispose of the packing materials until assembly is completed.

You may need the following tools:

- Two adjustable wrenches 
- One standard screwdriver 
- One phillips screwdriver 
- One rubber mallet 
- You may also need grease or petroleum jelly, a small amount of soapy water, and clear tape or masking tape.

Note: Assembly will be more convenient if you have a socket set, a set of open-end or closed-end wrenches, or a set of ratchet wrenches.

How to Identify Parts

To help you identify the small parts used in assembly, we have included a **PART IDENTIFICATION CHART** on pages 5 to 7. Use the chart to easily identify parts during each assembly step. **Note: Some small parts may have been pre-attached. If a part is not in the parts bag, check to see if it has been pre-attached.**

How to Orient Parts

As you assemble the weight system, make sure that all parts are oriented exactly as shown in the drawings.

Tightening Parts

Tighten all parts as you assemble them, unless instructed to do otherwise.

Questions?

If you have questions after reading these assembly instructions, please call the toll free number on the front cover of this manual.

The Four Stages of the Assembly Process

Frame Assembly—You will begin by assembling the base and the uprights that form the skeleton of the weight system.

Arm Assembly—During this stage you will assemble the arms and the leg lever.

Cable Assembly—During this stage you will attach the cables and pulleys that connect the arms to the weights.

Seat Assembly—During the final stage you will assemble the seat and the backrest.

Frame Assembly

1. **Before beginning assembly, make sure that you understand the information in the box on page 8. See the PART IDENTIFICATION CHART on pages 5 to 7 for help identifying small parts.**

Insert four M8 x 75mm Carriage Bolts (83) up through the Base (1). **Note: It may be helpful to place a piece of tape over each Carriage Bolt head to hold it in place.**

2. Insert an M8 x 75mm Carriage Bolt (83) up through the Stabilizer (3).

Attach the Base (1) and the two Weight Guides (18) to the Stabilizer (3) with two M10 x 85mm Bolts (81), two M10 Washers (80), two 21mm Steel Spacers (24), two M10 Nylon Locknuts (77), and an M8 Nylon Locknut (78). **Make sure that the indicated holes in the Weight Guides are nearer the bottom. Do not tighten the Nylon Locknuts yet.**

Attach the Upright (2) to the Base (1) with the two indicated M8 x 75mm Carriage Bolts (83) and two M8 Nylon Locknuts (78). **Do not tighten the Nylon Locknuts yet.**

3. Attach the Front Leg (10) to the Base (1) with the two M8 x 75mm Carriage Bolts (83) and two M8 Nylon Locknuts (78). **Do not tighten the Nylon Locknuts yet.**

Attach the Leg Lever Bumper (75) to the Front Leg (10) with an M4 x 16mm Self-tapping Screw (110) and an M4 Washer (104). **Make sure that the end of the Leg Lever Bumper is pointing upward.**

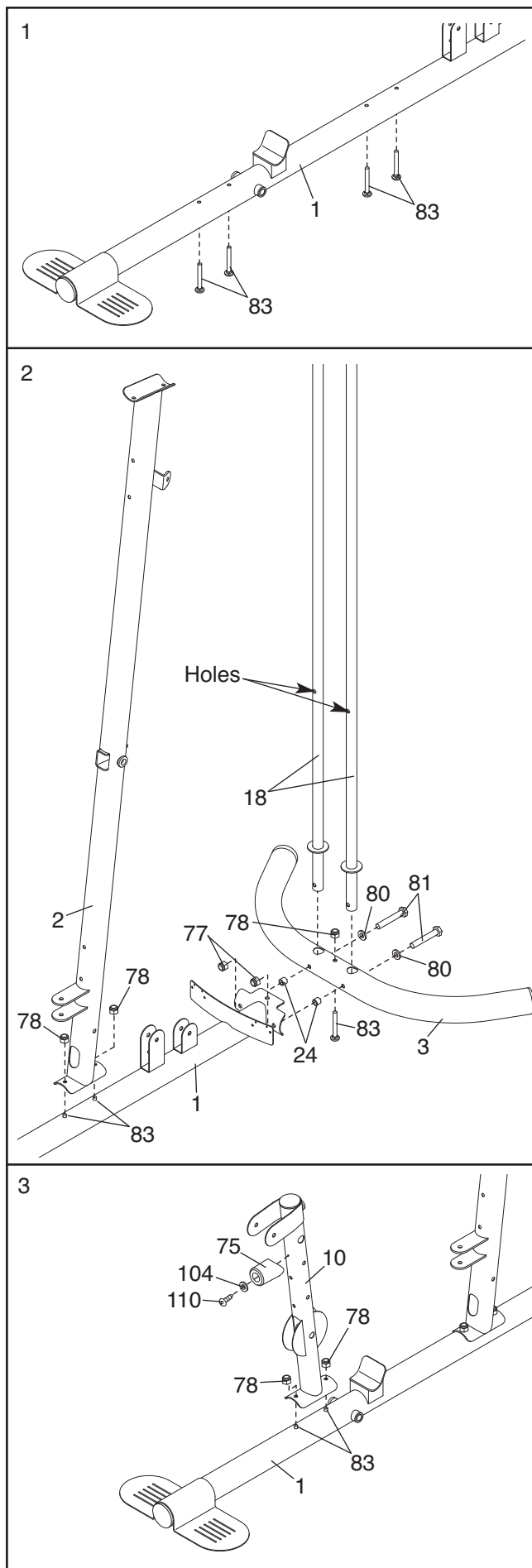

- Attach the Frame (9) to the Upright (2) with two M8 x 80mm Bolts (100), two M8 Washers (103), and two M8 Nylon Locknuts (78). **Do not tighten the Nylon Locknuts yet.**

Attach the Frame (9) to the Front Leg (10) with two M8 x 65mm Bolts (101), two M8 Washers (103), and two M8 Nylon Locknuts (78). **Do not tighten the Nylon Locknuts yet.**

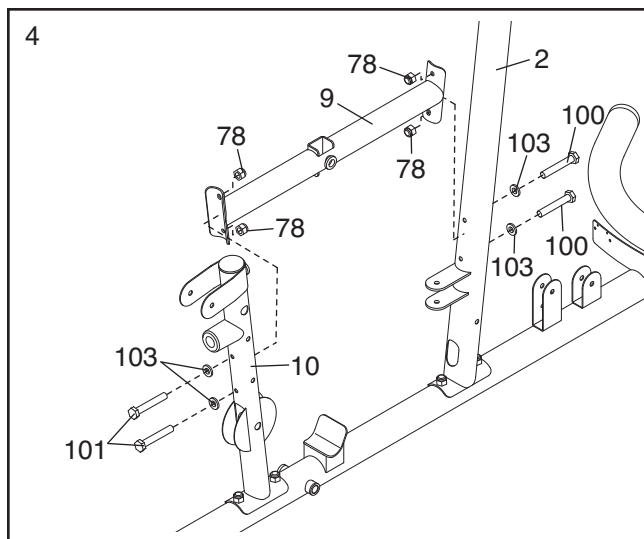

- Attach the Top Frame (4) to the Upright (2) with two M8 x 80mm Bolts (100), two M8 Washers (103), and two M8 Nylon Locknuts (78). **Do not tighten the Nylon Locknuts yet.**

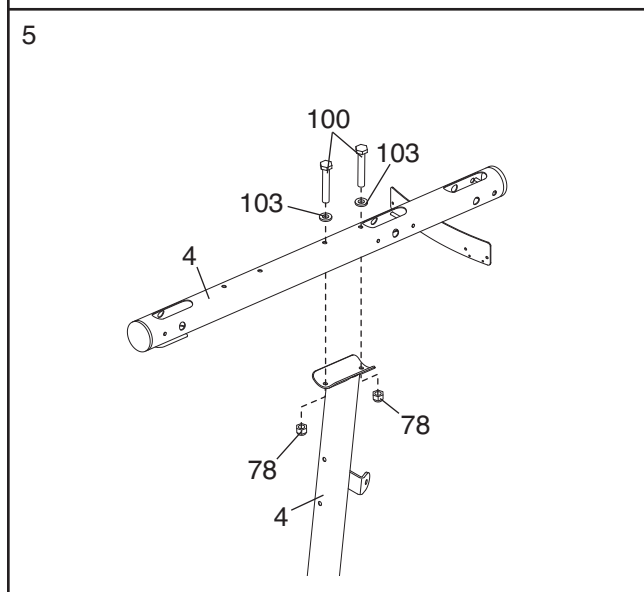

- Attach the Left Shroud (21) to the Top Frame (4) with two M4 x 12mm Self-tapping Screws (102).

See drawing 6A. Attach the bottom of the Left Shroud (21) to the Base (1) with two M4 x 12mm Self-tapping Screws (102).

Repeat this step for the Right Shroud (22).

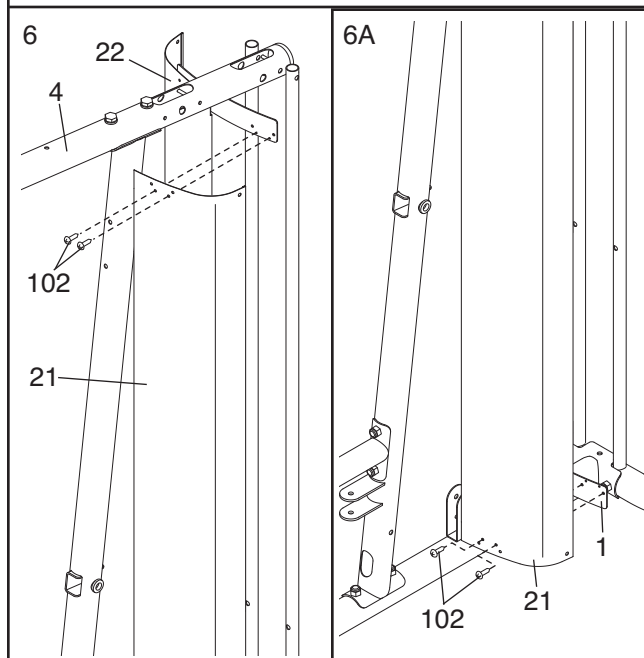

- Attach a Shroud Cover (23) to the Left and Right Shrouds (21, 22) with two M6 x 28mm Bolts (94), four M6 Washers (114), and two M6 Nylon Locknuts (107).

Attach the the Shroud Cover (23) to the Top Frame (4) with four M4 x 16mm Self-tapping Screws (110) and four M4 Washers (104).

See the inset drawing and attach the other Shroud Cover (23) in the same manner.

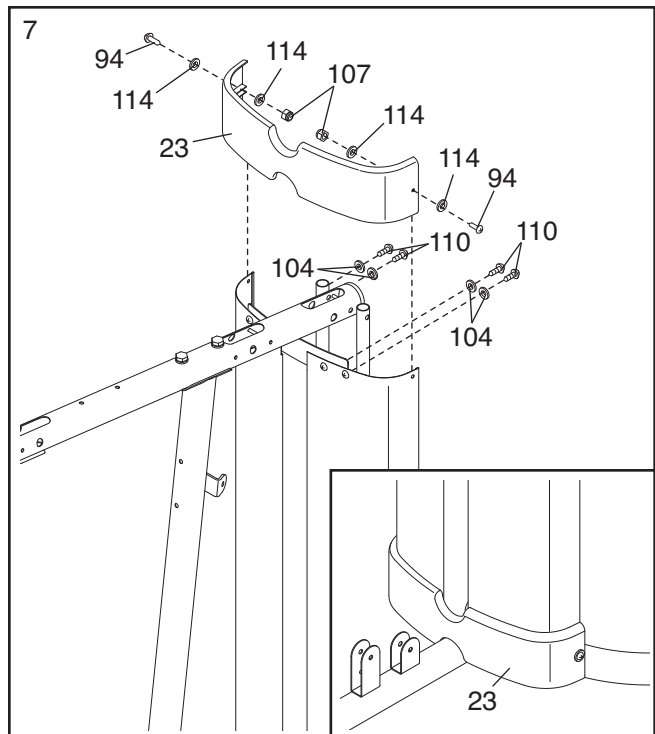

- Note: Some parts have been removed to show this step clearly.**

Slide the two Weight Bumpers (71) onto the Weight Guides (18). Orient nine Weights (19) with the pin holes on the bottom as shown. Slide the Weights onto the Weight Guides.

Insert the Weight Tube Cap (76) into the Weight Tube (20). Insert the Weight Tube into the nine Weights (19). **Make sure that the pin on the Weight Tube is oriented as shown.**

Lubricate the indicated holes in a Weight (19) with the included grease packet. Slide the Weight onto the Weight Guides (18).

Attach the Weight Guides (18) to the Top Frame (4) with an M10 x 155mm Bolt (96), two M10 Washers (80), two 13mm Steel Spacers (109), and an M10 Nylon Locknut (77).

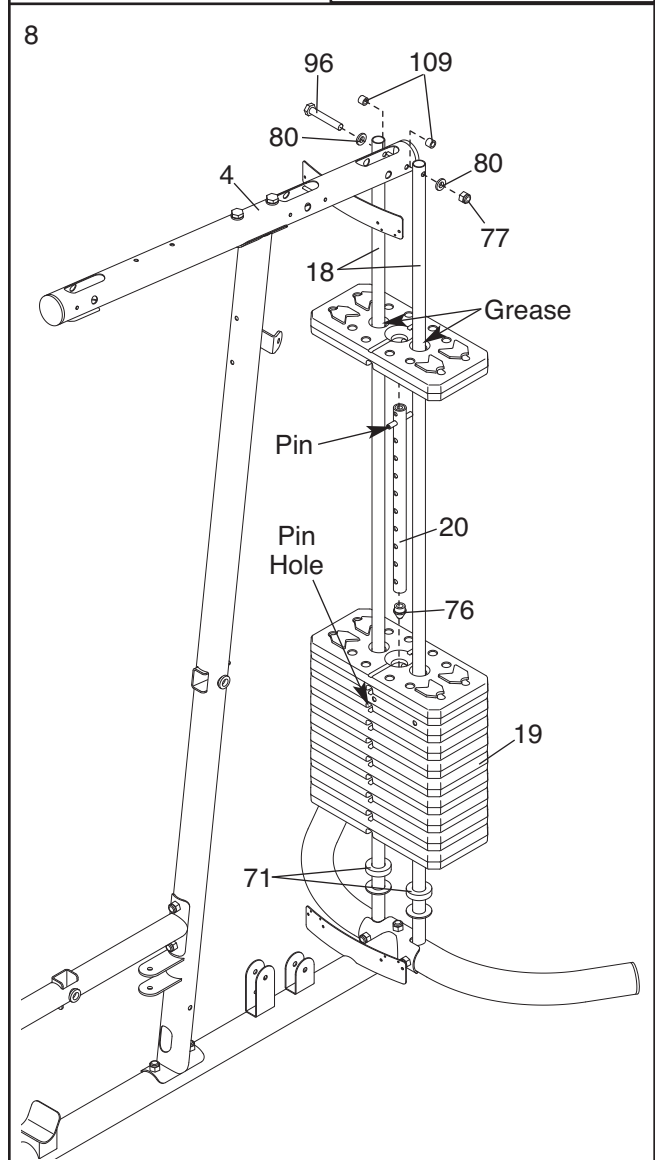

Arm Assembly

9. Attach the Butterfly Frame Brace (6) to the Upright (2) with two M8 x 80mm Bolts (100), two M8 Washers (103), and two M8 Nylon Locknuts (78). **Do not tighten the Nylon Locknuts yet.**

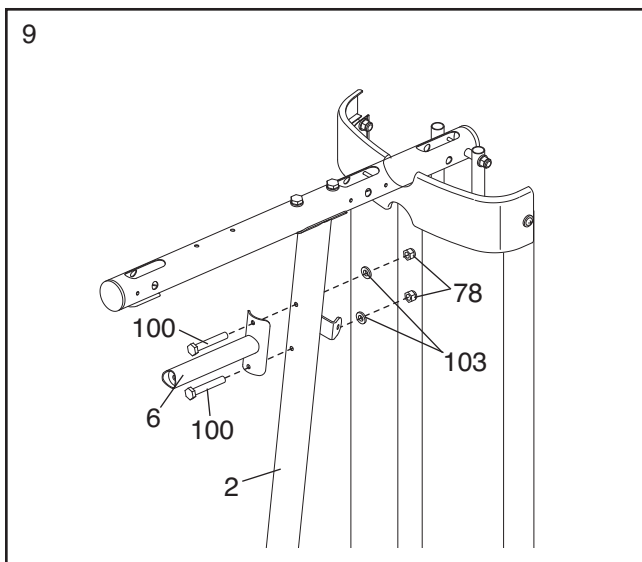

10. Apply grease in the locations shown. Insert a 56.5mm Spacer (69) into the indicated hole in the Leg Lever (12). Attach the Leg Lever to the Front Leg (10) with an M10 x 61mm Bolt Set (116). **Make sure that the indicated rod is oriented as shown. Make sure that the barrel of the Bolt Set is inserted through both sides of the bracket on the Front Leg.**

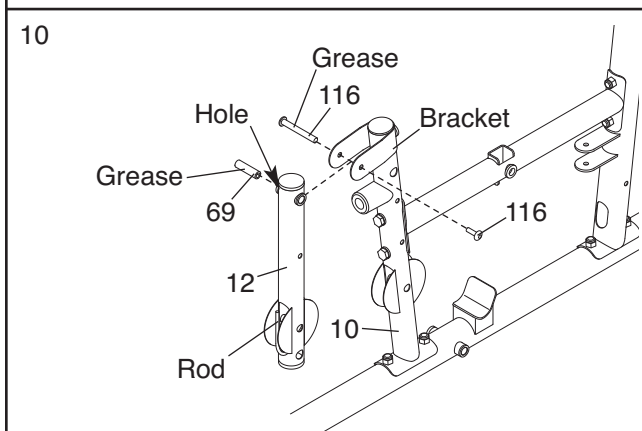

See the left inset drawing. Attach the Lock Plate (14) to the Front Leg (10) with an M8 x 69mm Shoulder Bolt (87), an M8 Washer (103), and an M8 Nylon Locknut (78).

See the right inset drawing. Insert the Lock Plate Pin (95) through the Lock Plate (14) and the Leg Lever (12). Attach the tether on the Lock Plate Pin to the Front Leg (10) with an M4 x 12mm Self-tapping Screw (102).

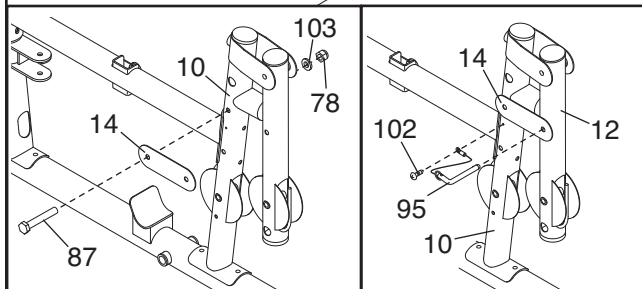

11. Attach the Butterfly Frame (5) to the Top Frame (4) with two M8 x 80mm Bolts (100), two M8 Washers (103), and two M8 Nylon Locknuts (78). **Do not tighten the Nylon Locknuts yet.**

Attach the Butterfly Frame (5) to the Butterfly Frame Brace (6) with an M10 x 75mm Button Screw (118).

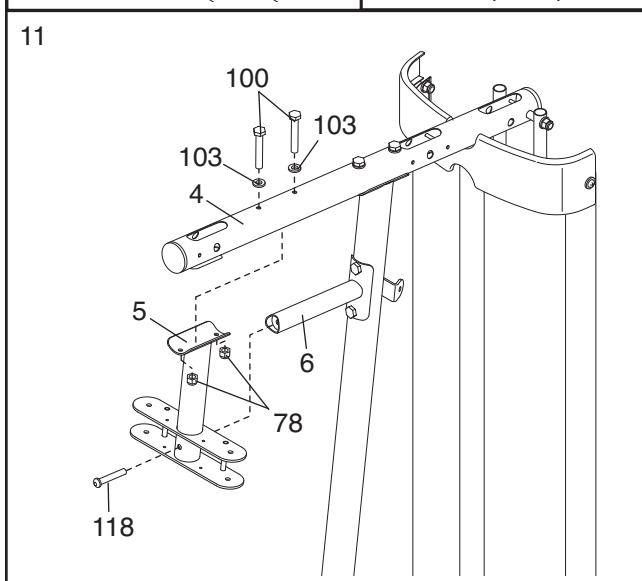

12. Apply grease in the locations shown and attach the Left Butterfly Bracket (28) to the Butterfly Frame (5) with an M10 x 80mm Bolt (84) and an M10 Nylon Locknut (77).

Repeat this step for the Right Butterfly Bracket (29).

Tighten the Nylon Locknuts (77, 78, 107) used in steps 2 through 12.

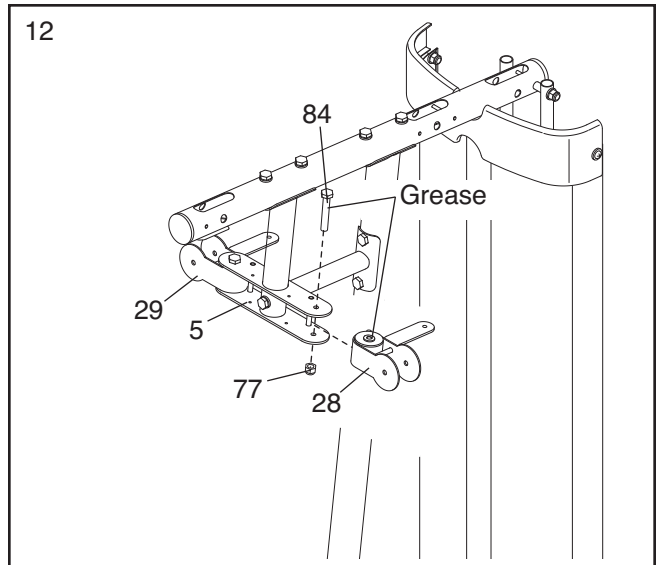

13. Attach a Butterfly Handle (27) to the Left Butterfly Arm (25) with an M10 x 65mm Button Bolt (106), two M10 Washers (80), two 13mm Steel Spacers (109), and an M10 Nylon Locknut (77).

Secure the Butterfly Handle (27) with an M10 x 82mm Button Screw (92) and an M10 Large Washer (105).

Repeat this step for the Right Butterfly Arm and Butterfly Handle (26, 27).

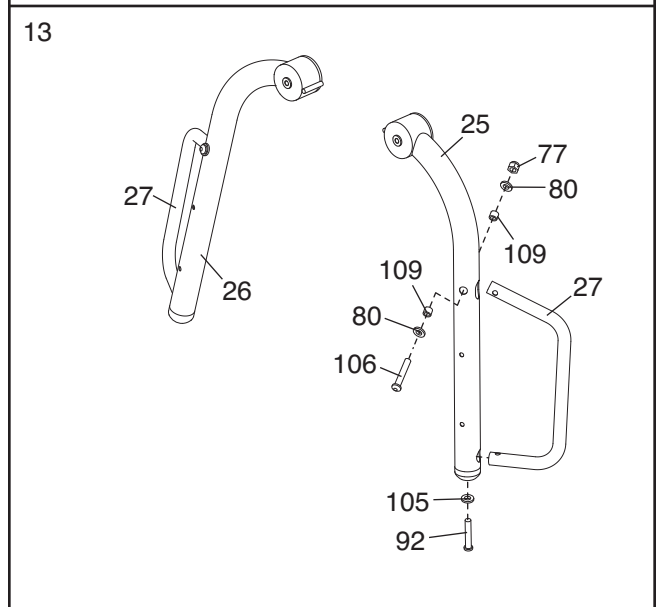

14. Apply grease in the locations shown and attach the Right Butterfly Arm (26) to the Right Butterfly Bracket (29) with an M10 x 75mm Bolt (82) and an M10 Nylon Locknut (77). Press a Bolt Cap (44) onto the end of the Bolt. **Do not overtighten the Bolt; the Butterfly Arm must be able to pivot freely.**

Repeat this step for the Left Butterfly Arm (25).

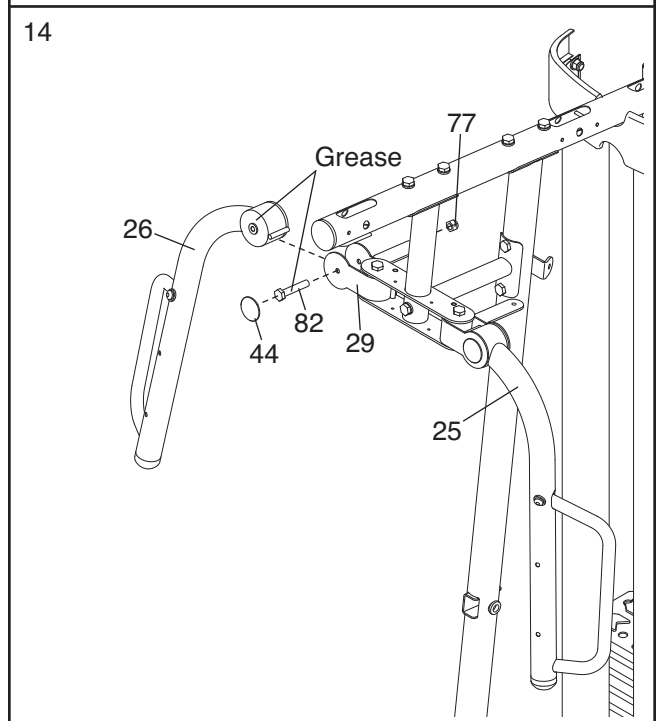

15. Position a Press Arm Handle (17) with the 90° bend oriented as shown. Attach the Press Arm Handle to the Right Press Arm (16) with two M10 x 65mm Button Bolts (106), four M10 Washers (80), four 11mm Spacers (99), and two M10 Nylon Locknuts (77).

Repeat this step for the Left Press Arm (not shown).

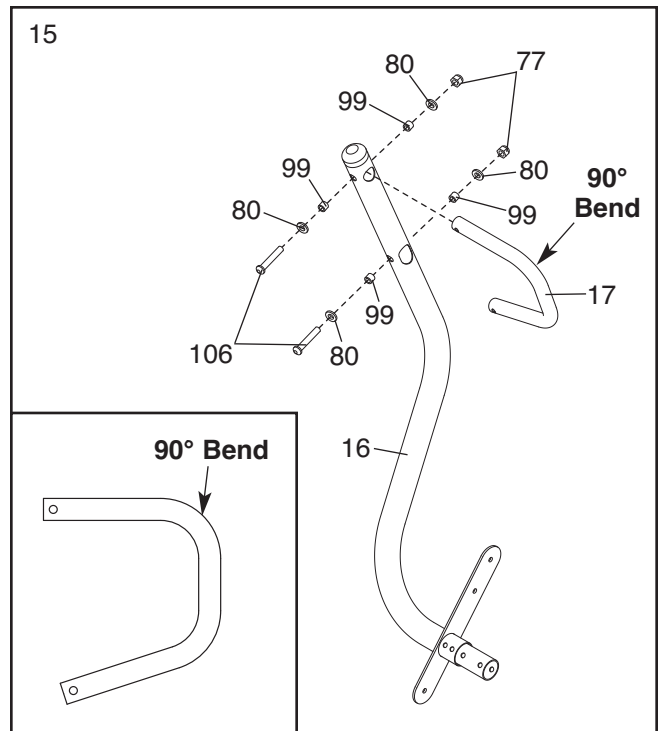

16. Attach the Left Press Arm (15) to the Right Press Arm (16) with an M10 x 110mm Bolt (93), an 89.5mm Spacer (59) and an M10 Nylon Locknut (77).

Finish attaching the Press Arms (15, 16) with two M10 x 65mm Bolts (85), two M10 Washers (80), and two M10 Nylon Locknuts (77). **Do not tighten the Nylon Locknuts yet.**

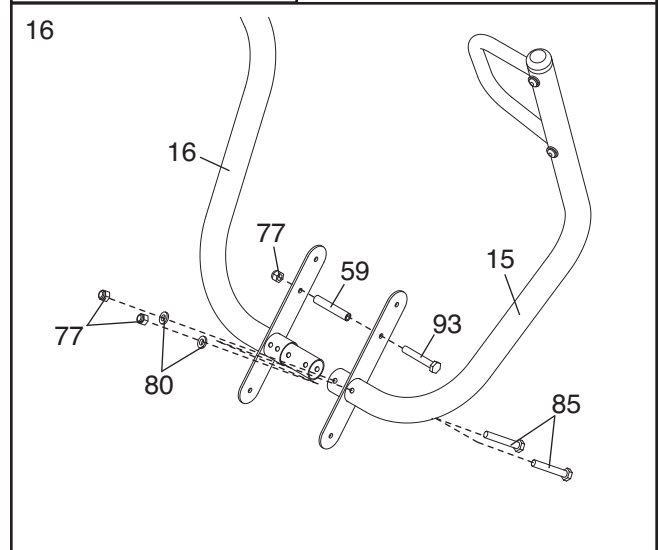

17. Apply grease in the locations shown and attach the Left and Right Press Arms (15, 16) to the Base (1) with an M10 x 110mm Bolt (93), an 89.5mm Spacer (59), and an M10 Nylon Locknut (77). **Do not overtighten the Nylon Locknut; the Press Arms (15, 16) must be able to pivot freely.**

Tighten the Nylon Locknuts used in step 16.

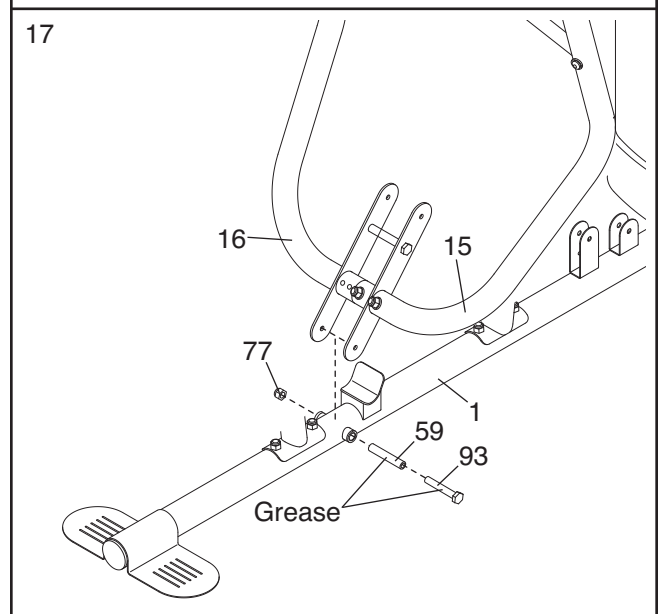

Cable Assembly

18. See the **CABLE DIAGRAM** on page 28 to identify the cables as you assemble them.

Identify the Butterfly Cable (50). Grease an M8 x 22mm Shoulder Bolt (90). Attach the Cable to the Left Butterfly Bracket (28) with the Shoulder Bolt and an M8 Nylon Locknut (78). **Make sure that the flat edge of the Cable is against the Butterfly Arm.** Do not overtighten the Shoulder Bolt; the Cable must pivot freely.

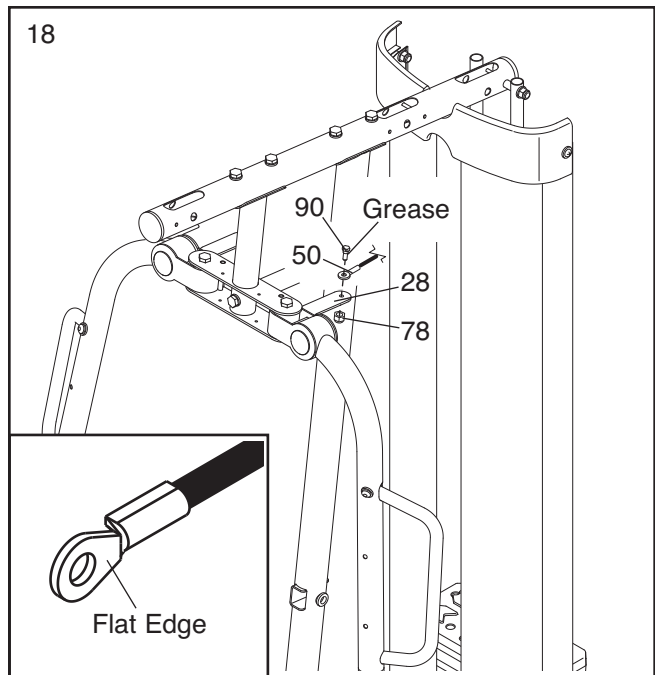

19. Wrap the Butterfly Cable (50) over a "V"-pulley (47). Attach the "V"-pulley, a Long Cable Trap (54), an M10 Washer (80), and two Guards (54) to the Upright (2) with an M10 x 60mm Bolt (79) and an M10 Nylon Locknut (77).

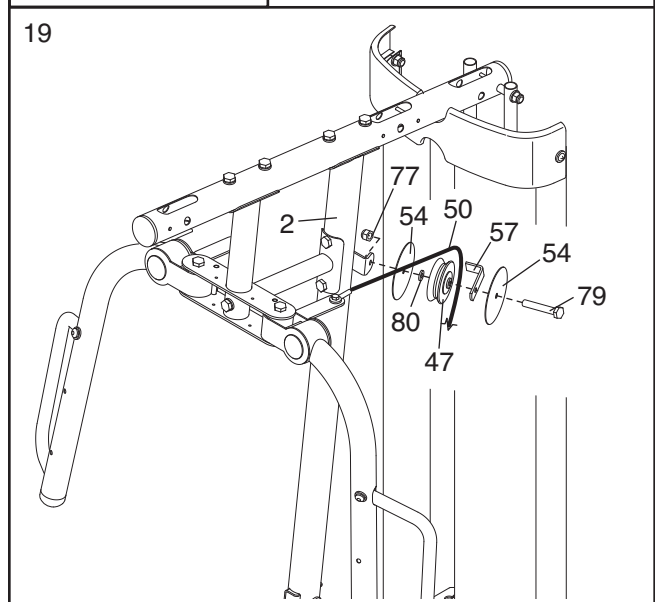

20. Wrap the Butterfly Cable (50) under a 90mm Pulley (48). Attach the Pulley and two Half Guards (55) to the Double "U"-bracket (61) with an M10 x 45mm Bolt (86) and an M10 Nylon Locknut (77). **Make sure that the Half Guards are oriented as shown.**

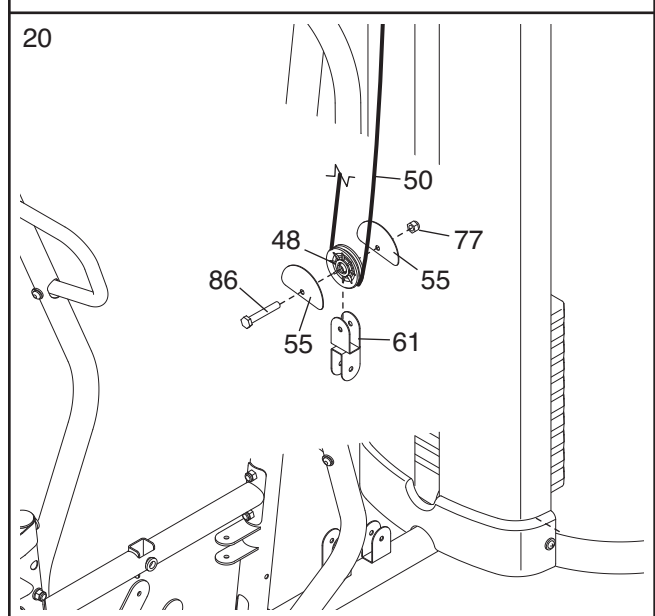

21. Wrap the Butterfly Cable (50) over a “V”-pulley (47). Attach the “V”-pulley, a Long Cable Trap (57), an M10 Washer (80), and two Guards (54) to the Upright (2) with an M10 x 60mm Bolt (79) and an M10 Nylon Locknut (77).

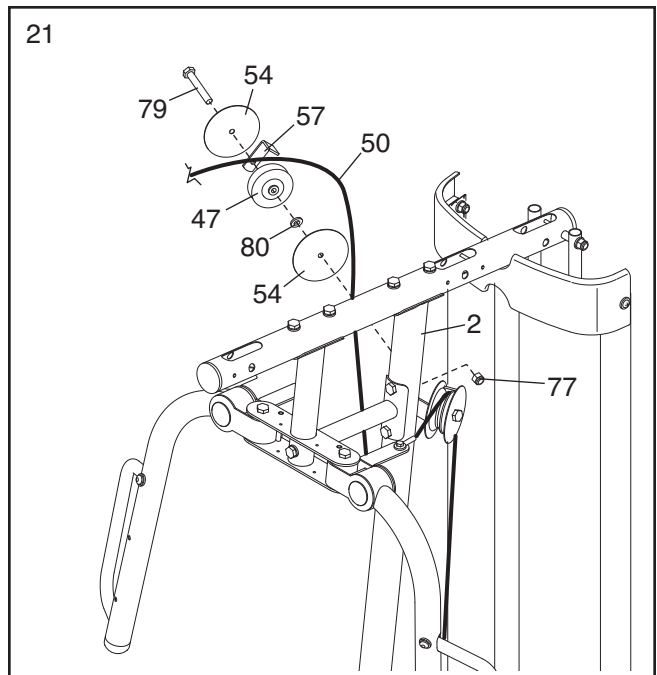

22. Grease an M8 x 22mm Shoulder Bolt (90). Attach the Butterfly Cable (50) to the Right Butterfly Arm (29) with the Shoulder Bolt and an M8 Nylon Locknut (78). **Make sure that the flat edge of the Cable is against the Butterfly Arm.**

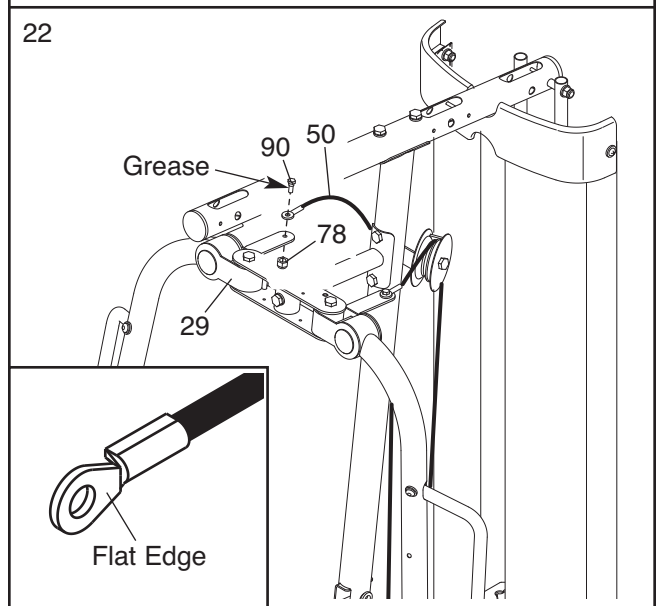

23. **Identify the Lat Cable (49).** Route the Cable through the Top Frame (4) and over a 90mm Pulley (48). Attach the Pulley inside the Top Frame with an M10 x 80mm Bolt (84), two M10 Washers (80), two 19mm Spacers (67), and an M10 Nylon Locknut (77).

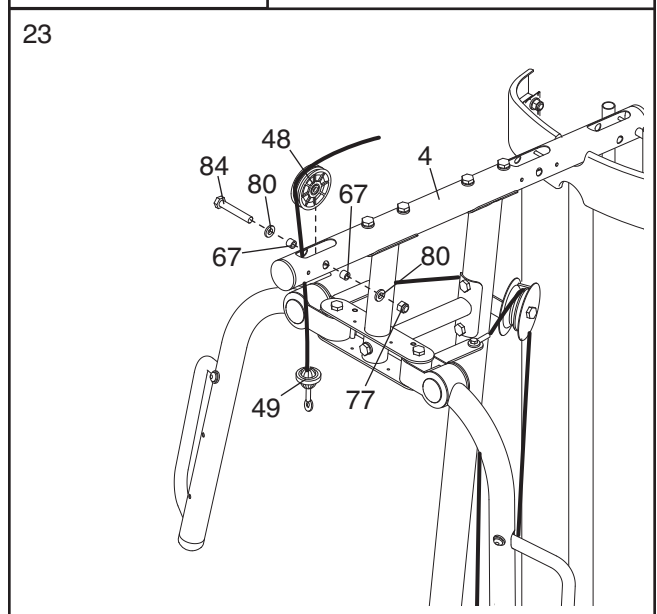

24. Route the Lat Cable (49) over a Thin Pulley (113) and down through the Top Frame (4). Hold the Thin Pulley inside the Top Frame. Next, insert an M10 x 80mm Bolt (84) through an M10 Washer (80), a 19mm Spacer (67), the Top Frame, and the Thin Pulley.

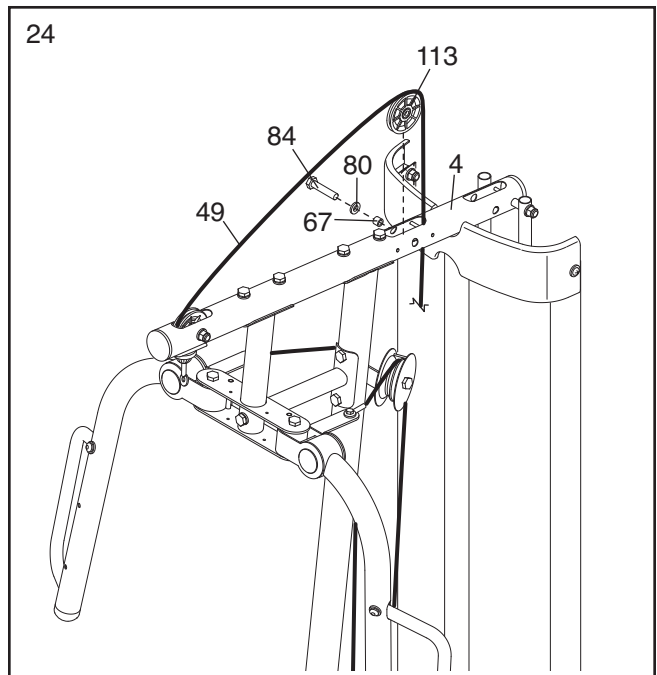

25. Wrap the Lat Cable (49) under a 90mm Pulley (48). Attach the Pulley, a Cable Trap (56), and two Half Guards (55) at the second hole from the top of the two Pulley Plates (60) with an M10 x 50mm Bolt (97) and an M10 Nylon Locknut (77). **Make sure that the Cable Trap and Half Guards are oriented as shown.**

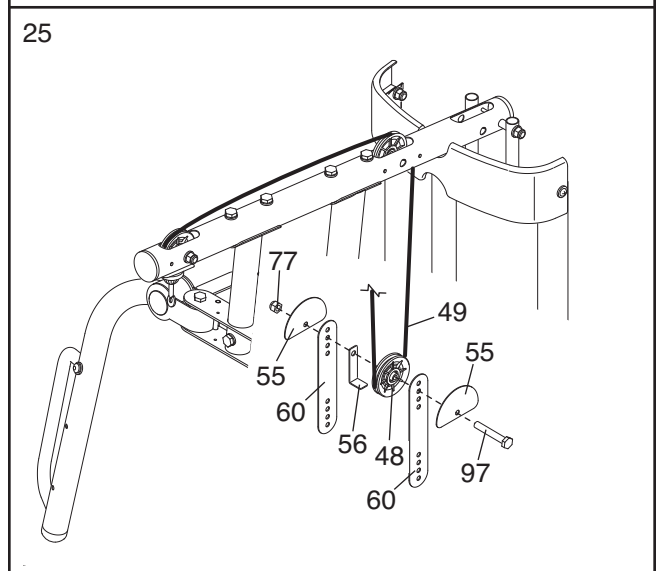

26. Route the Lat Cable (49) up through the Top Frame (4) and wrap the Cable over a Thin Pulley (113). Pull the M10 x 80mm Bolt (84) out of the Top Frame until it is flush with the first Thin Pulley from step 24. **Do not remove the Bolt completely from the Top Frame.**

Hold the second Thin Pulley (113) inside the Top Frame (4) and attach it with the M10 x 80mm Bolt (84), a 19mm Spacer (67), an M10 Washer (80), and an M10 Nylon Locknut (77).

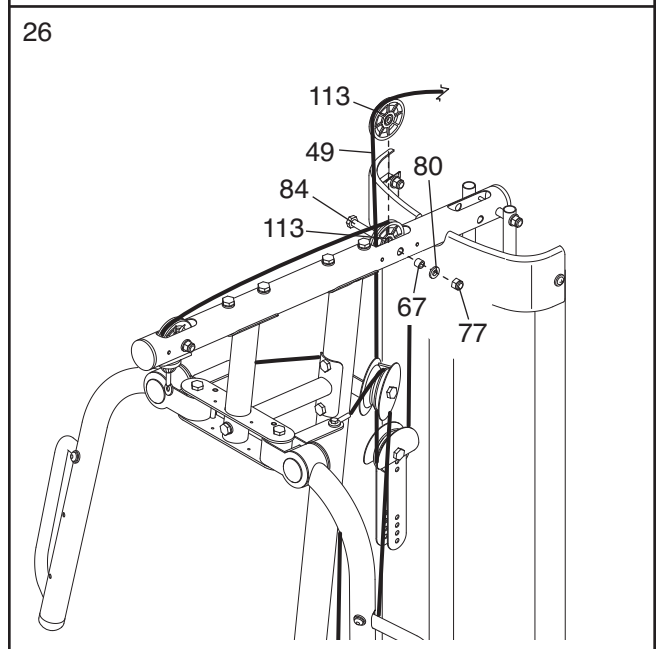

27. Wrap the Lat Cable (49) around a 90mm Pulley (48) and route the Cable down through the Top Frame (4). Attach the Pulley inside the Top Frame with an M10 x 80mm Bolt (84), two M10 Washers (80), two 19mm Spacers (67), and an M10 Nylon Locknut (77).

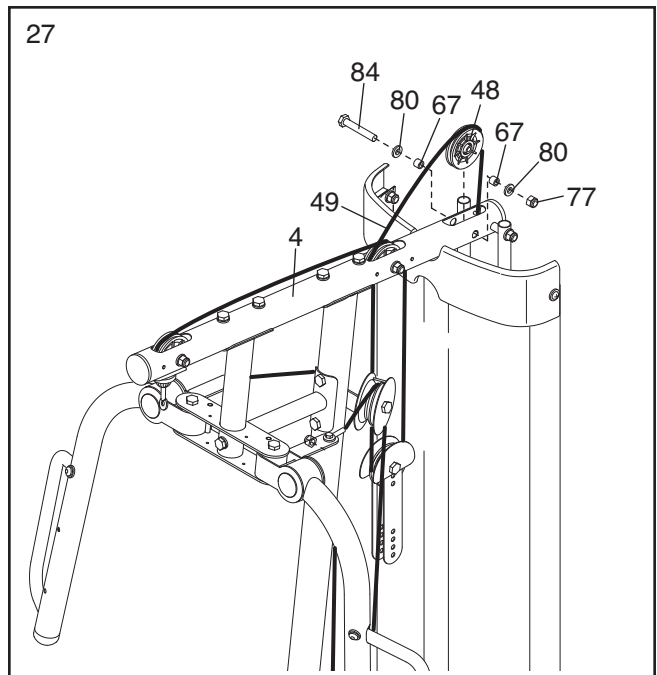

28. Set an M12 Large Washer (98) on top of the Weight Tube (20). Thread the M12 Nut (112) all the way onto the Lat Cable (49).

Thread the Lat Cable (49) into the Weight Tube (20) **two turns**. Tighten the M12 Nut (112) against the M12 Large Washer (98).

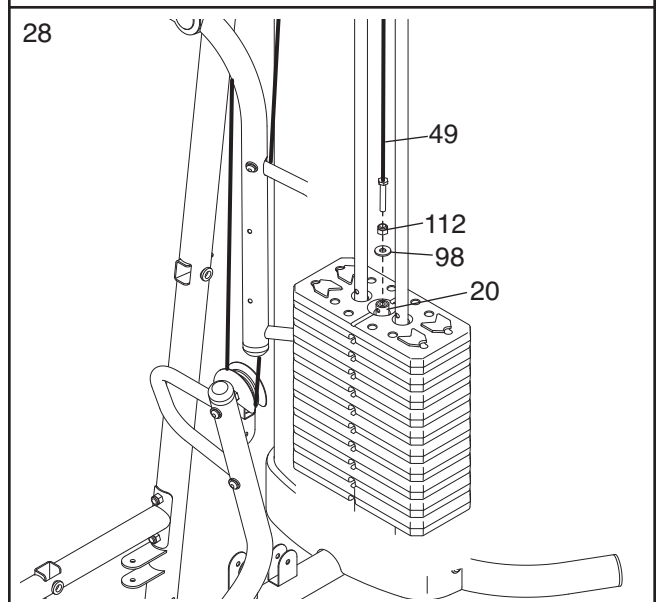

29. **Identify the Leg Lever Cable (51).** Route the Cable through the Leg Lever (12) and the Front Leg (10).

Insert a 90mm Pulley (48) into the Leg Lever (12) from behind as shown. Attach the Pulley with an M10 x 65mm Bolt (85), two M10 Washers (80), two 13mm Steel Spacers (109), and an M10 Nylon Locknut (77).

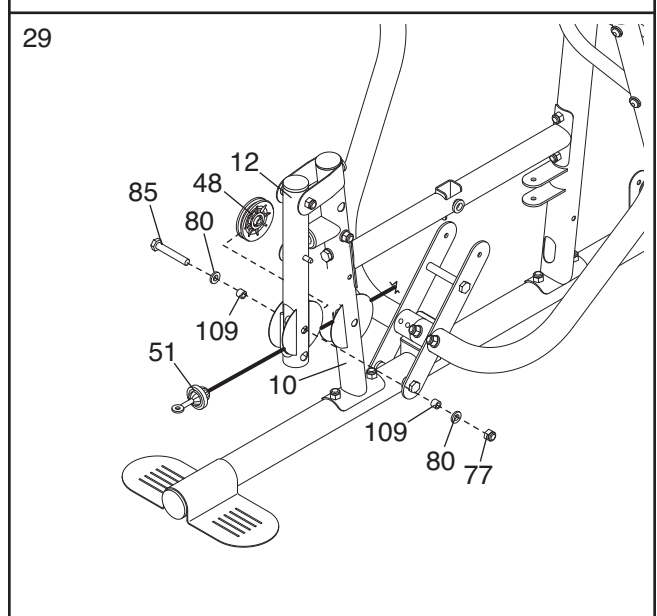

30. Attach a 90mm Pulley (48) to the Front Leg (10) with an M10 x 65mm Bolt (85), two M10 Washers (80), two 13mm Steel Spacers (109), and an M10 Nylon Locknut (77). **Make sure that the Leg Lever Cable (51) is under the Pulley.**

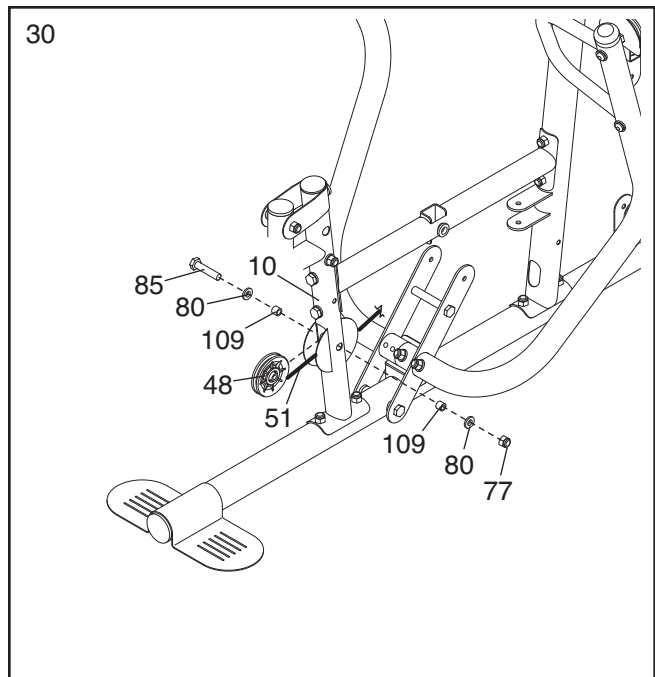

31. Route the Leg Lever Cable (51) under the 89.5mm Spacer (59), through the Upright (2), and under the indicated rod in the Base (1). Wrap the Leg Lever Cable around a 90mm Pulley (48). Attach the Pulley to the Base with an M10 x 45mm Bolt (86), two Half Guards (55), and an M10 Nylon Locknut (77).

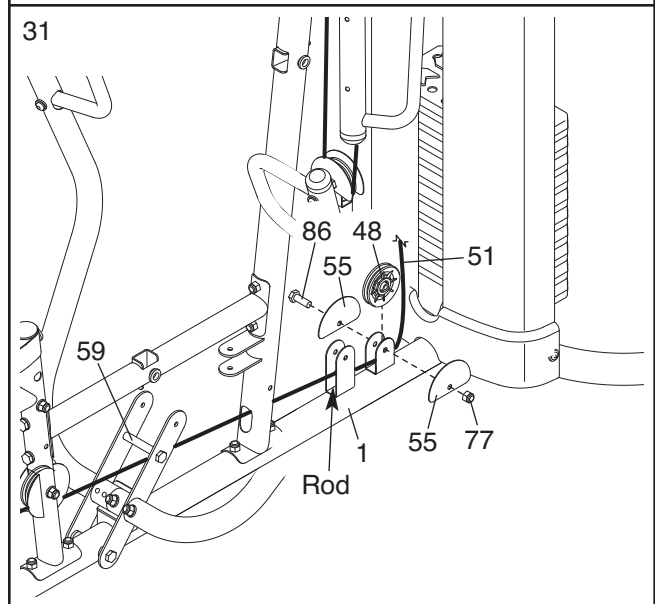

32. Wrap the Leg Lever Cable (51) over a 90mm Pulley (48). Attach the Pulley, a Cable Trap (56), and two Half Guards (55) to the second hole from the bottom of the Pulley Plates (60) with an M10 x 50mm Bolt (97) and an M10 Nylon Locknut (77). **Make sure that the Cable Trap and the Half Guards are oriented as shown.**

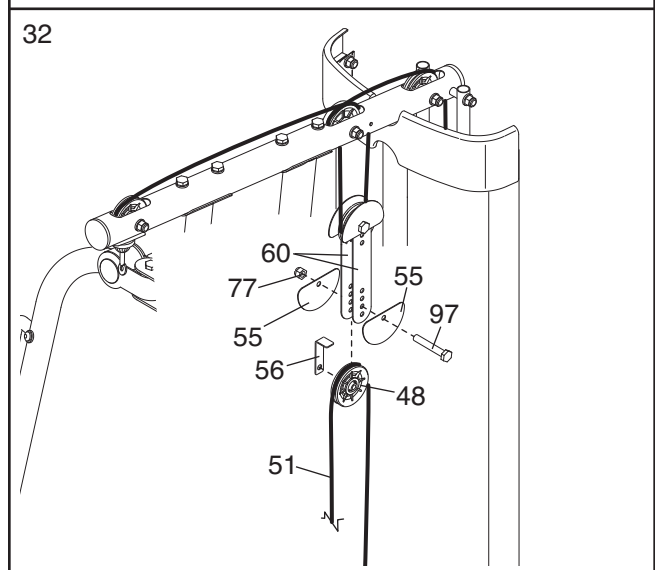

33. Wrap the Leg Lever Cable (51) under a 90mm Pulley (48). Attach the Pulley to the Base (1) with an M10 x 45mm Bolt (86), two Half Guards (55), and an M10 Nylon Locknut (77).

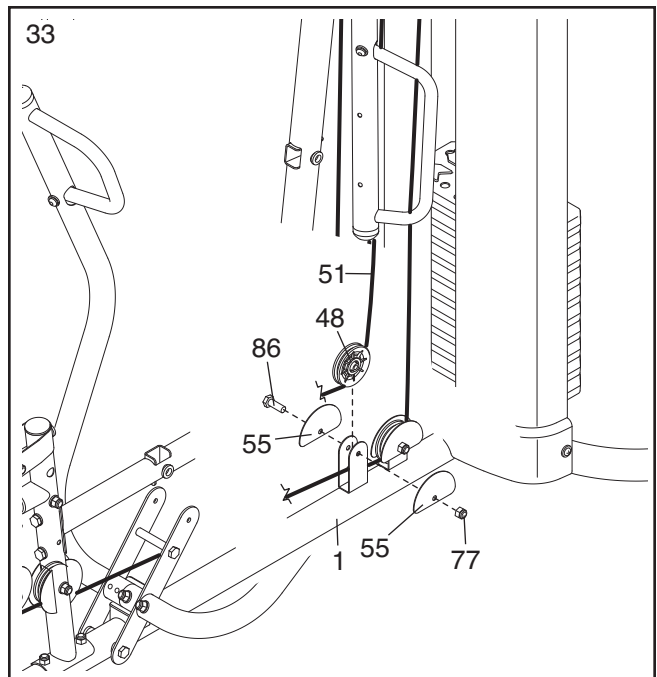

34. Wrap the Leg Lever Cable (51) over a 90mm Pulley (48). Attach the Pulley to the Double "U"-bracket (61) with an M10 x 45mm Bolt (86), two Half Guards (55), and an M10 Nylon Locknut (77).

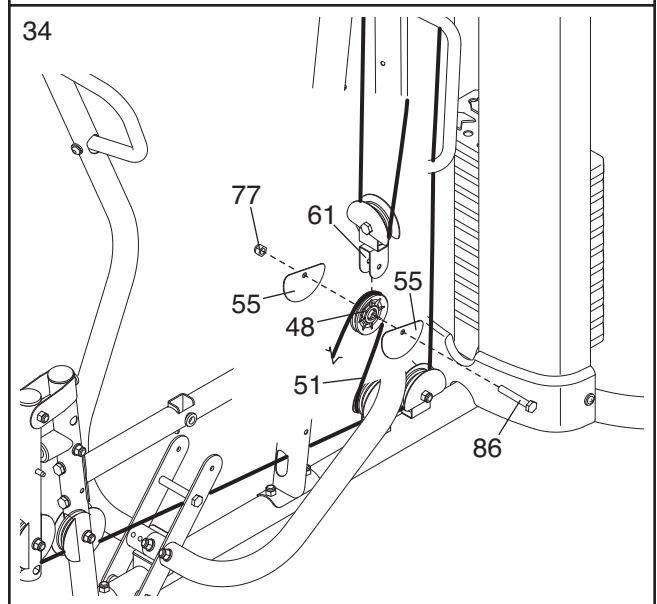

35. Wrap the Leg Lever Cable (51) under a 90mm Pulley (48). Attach the Pulley to the Upright (2) with an M10 x 120mm Bolt (115), two Half Guards (55), an M10 Washer (80), and a Cable Trap (56).

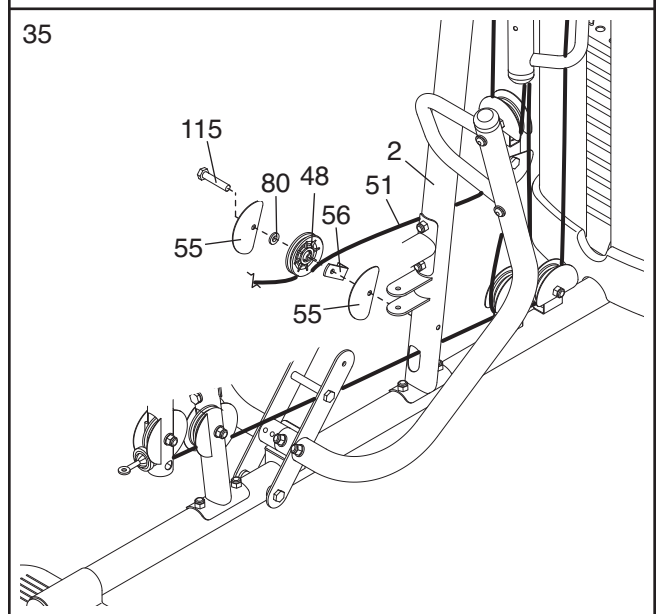

36. Wrap the Leg Lever Cable (51) under a 90mm Pulley (48). Attach the Pulley to the Right Press Arm (16) with an M10 x 50mm Bolt (97), two Half Guards (55), a Cable Trap (56), an M10 Washer (80), and an M10 Nylon Locknut (77). **Make sure that the Cable Trap and Half Guards are oriented as shown.**

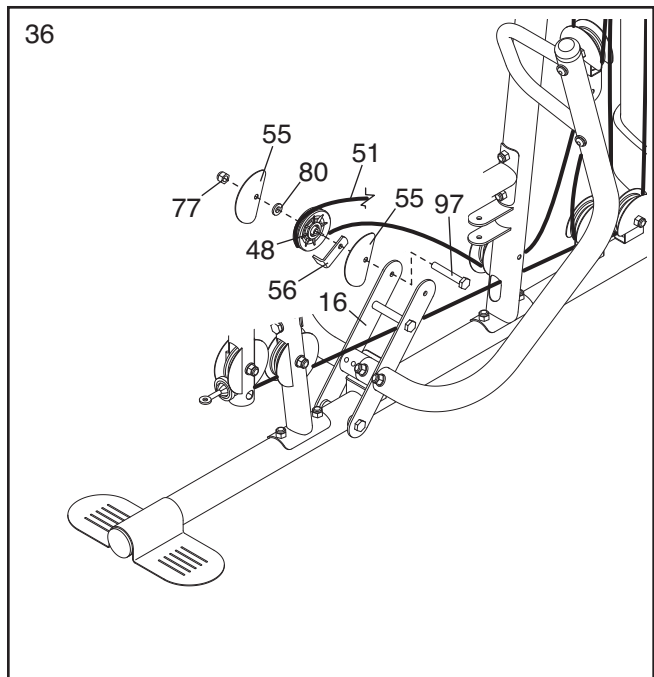

37. Wrap the Leg Lever Cable (51) around a “V”-pulley (47). Attach the Pulley to the Upright (2) with an M10 x 70mm Bolt (108), two Half Guards (55), an M10 Washer (80), a Long Cable Trap (57), and an M10 Nylon Locknut (77). **Make sure that the Cable Trap and Half Guards are oriented as shown.**

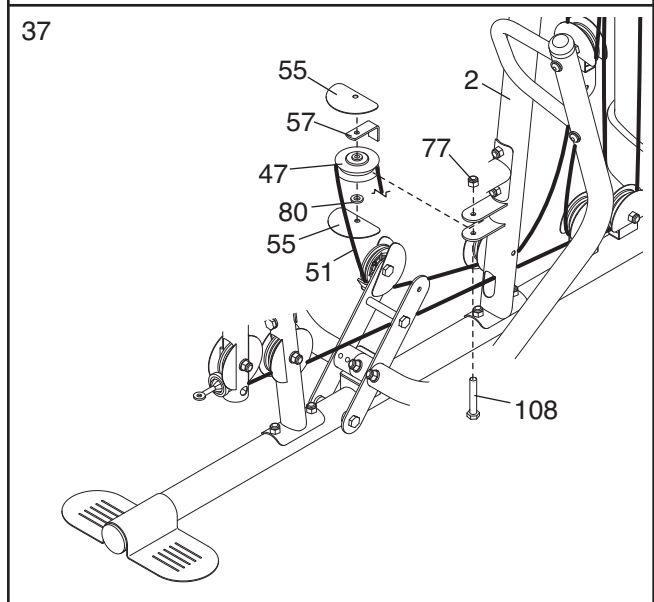

38. Wrap the Leg Lever Cable (51) around a 90mm Pulley (48). Attach the Pulley to the Left Press Arm (15) with an M10 x 50mm Bolt (97), two Half Guards (55), an M10 Washer (80), and a Cable Trap (56). **Make sure that the Cable Trap and Half Guards are oriented as shown.**

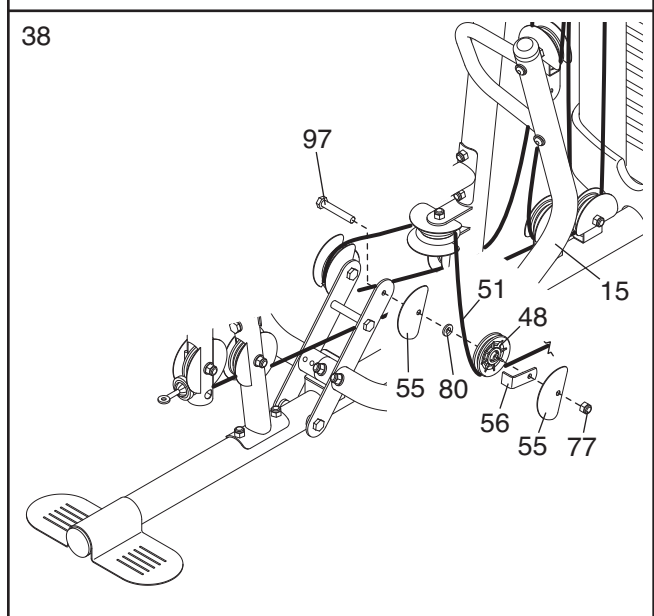

39. Attach the Leg Lever Cable (51) to the Upright (2) with the M10 x 120mm Bolt (115), an M10 Washer (80), a 7mm Spacer (111), and an M10 Nylon Locknut (77). **Make sure that the flat edge of the Cable is against the Spacer.**

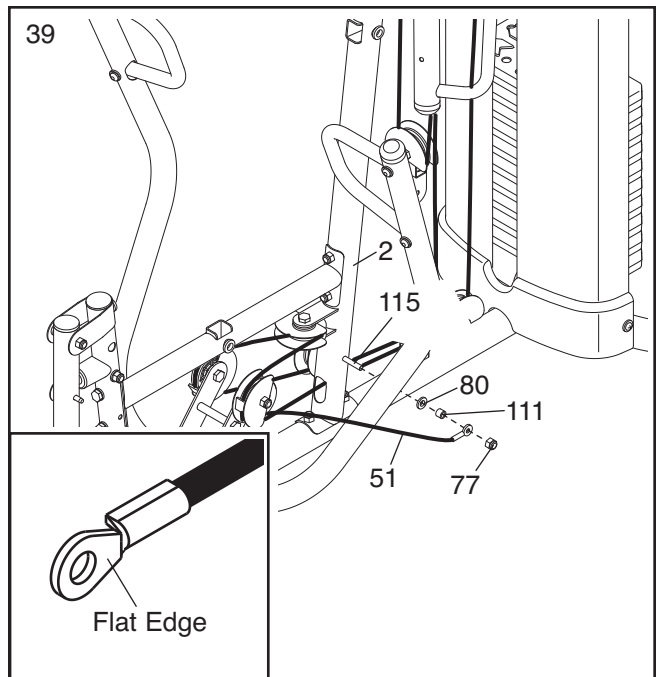

Seat Assembly

40. Attach the Right Butterfly Pad (35) to the Right Butterfly Arm (26) with two M6 x 65mm Button Screws (91) and two M6 Washers (114).

Repeat this step for the Left Butterfly Pad (34).

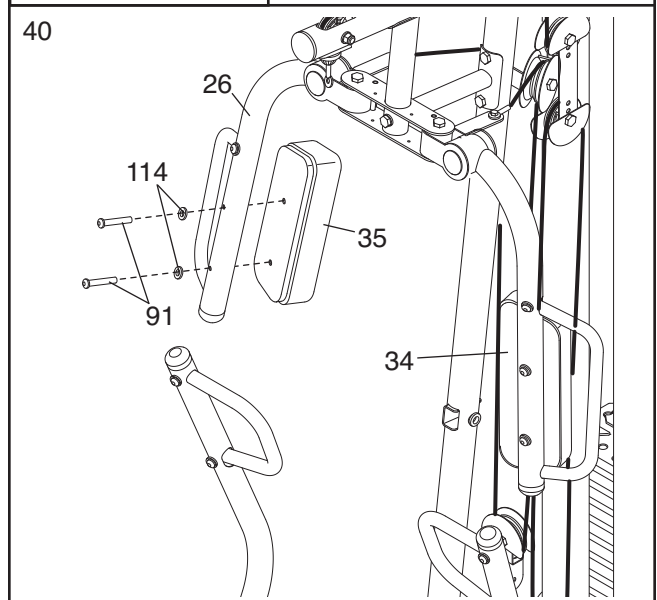

41. Attach the Backrest (31) to the Backrest Frame (7) with two M6 x 20mm Screws (88), an M6 x 38mm Screw (89), and an M6 Washer (114).

Insert the Backrest Frame (7) into the Upright (2) and tighten the Backrest Adjustment Knob (53) into the Upright. **Make sure that the Adjustment Knob passes through one of the holes in the Backrest Frame.**

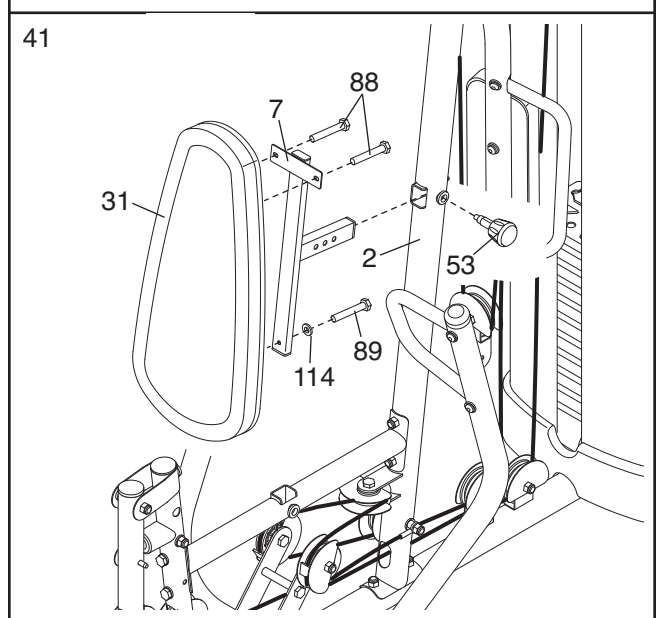

42. Attach the Seat (32) to the Seat Frame (8) with two M6 x 20mm Screws (88), an M6 x 38mm Screw (89), and an M6 Washer (114).

Insert the Seat Frame (8) into the Frame (9). Tighten the Seat Adjustment Knob (52) into the Frame and the Seat Frame. **Make sure that the Adjustment Knob passes through one of the holes in the Seat Frame.**

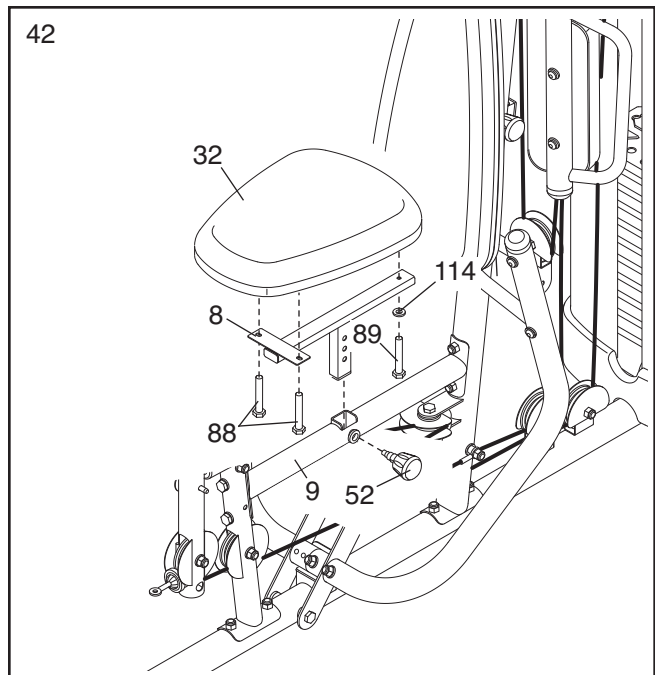

43. Insert a Pad Tube (13) into the indicated hole in the Front Leg (10). Slide a Foam Pad (36) onto each end of the Pad Tube.

Press a Pad Cap (37) into an end of each Foam Pad (36).

Repeat this step for the other Pad Tube (13) and the Leg Lever (12). Note: Lift the Leg Lever Cable (51) when inserting a Pad Tube into the hole in the bottom of the Leg Lever.

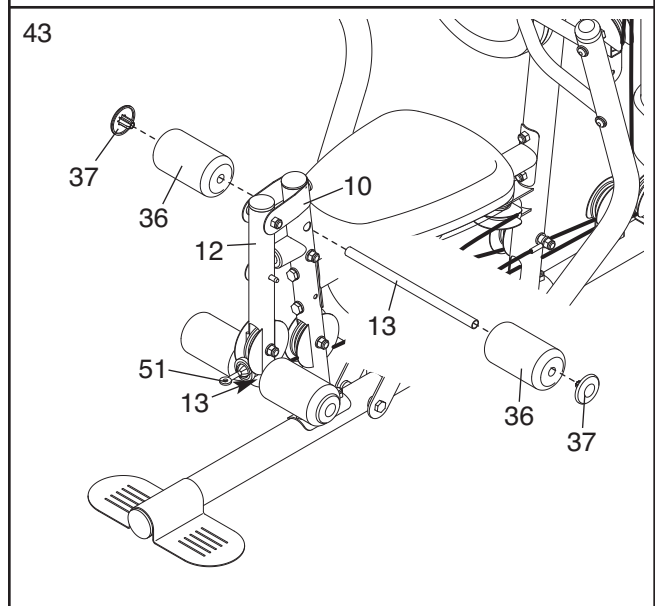

44. Attach the Butterfly Cover (30) to the Butterfly Bracket (5) with four M4 x 12mm Self-tapping Screws (102).

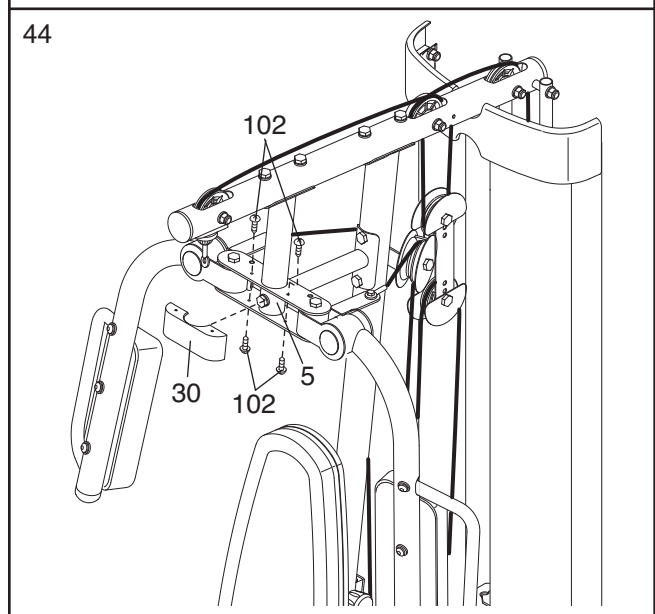

45. Attach the Curl Pad (33) to the Curl Post (11) with two M6 x 20mm Screws (88).

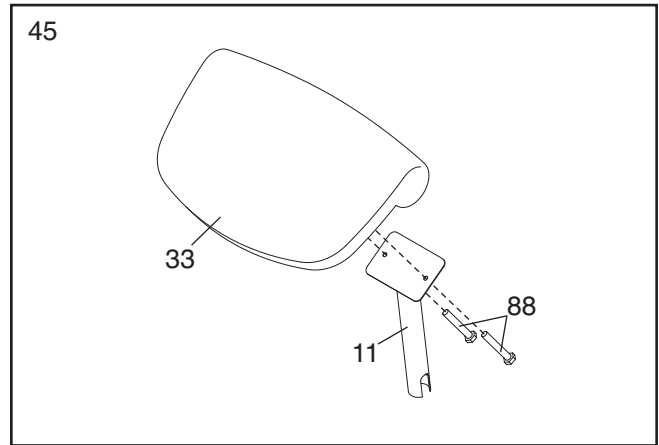

46. Make sure that all parts have been properly tightened. The use of the remaining parts will be explained in ADJUSTMENTS, beginning on the following page.

Before using the weight system, pull each cable a few times to make sure that the cables move smoothly over the pulleys. If one of the cables does not move smoothly, find and correct the problem. **IMPORTANT: If the cables are not properly installed, they may be damaged when heavy weight is used. See the CABLE DIAGRAMS on page 28 of this manual for proper cable routing. If there is any slack in the cables, you will need to remove the slack by tightening the cables. See MAINTENANCE on page 29.**

ADJUSTMENTS

This section explains how to adjust the weight system. Refer to the accompanying exercise guide to see the correct form for each exercise.

Make sure that all parts are properly tightened each time the weight system is used. Replace any worn parts immediately. The weight system can be cleaned with a damp cloth and a mild, non-abrasive detergent. Do not use solvents.

CHANGING THE WEIGHT SETTING

To change the weight setting of the weight stack, insert the Weight Pin (70) under the desired Weight (19). Make sure to insert the Weight Pin until the bent end of the Weight Pin is touching the Weights, and turn the bent end upward. **Note: The weight system works best when at least two Weights are used.**

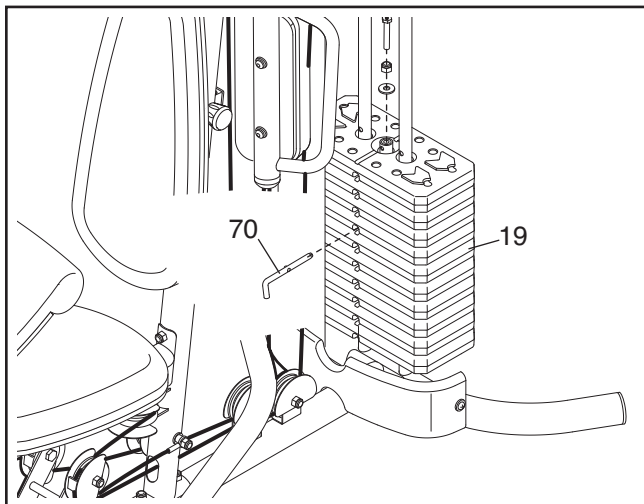

ATTACHING THE ACCESSORIES

To attach the Lat Bar (63) to the Lat Cable (49), attach a Weight Clip (66) to the Lat Cable and the Lat Bar. **Note: For some exercises, you will need to attach the Chain (not shown) to the Weight Clip and use another Weight Clip to attach the Chain to the Lat Bar.**

Attach the other accessories to the weight system in the same manner.

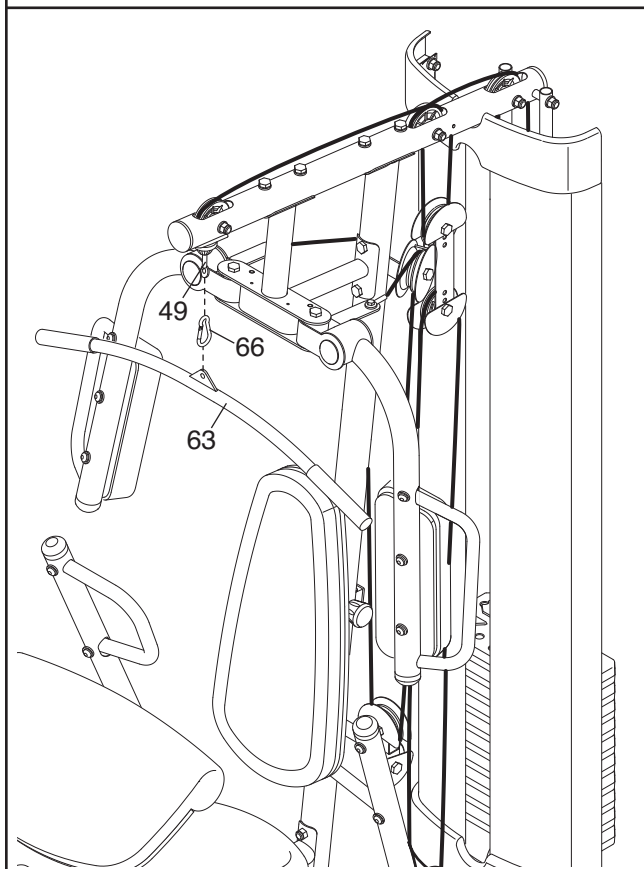

USING THE CURL PAD

To use the Curl Pad (33), remove the indicated 50mm Round Inner Cap (39) and insert the Curl Post (11) into the Front Leg (10). Tighten the Curl Adjustment Knob (58) into the Front Leg. Make sure that the Adjustment Knob passes through a hole in the Curl Post.

When you are performing exercises that do not require the Curl Pad, remove the Curl Pad (33) and reinsert the 50mm Round Inner Cap (39) into the Front Leg (10). **Note: You must remove the Curl Pad to use the press arms.**

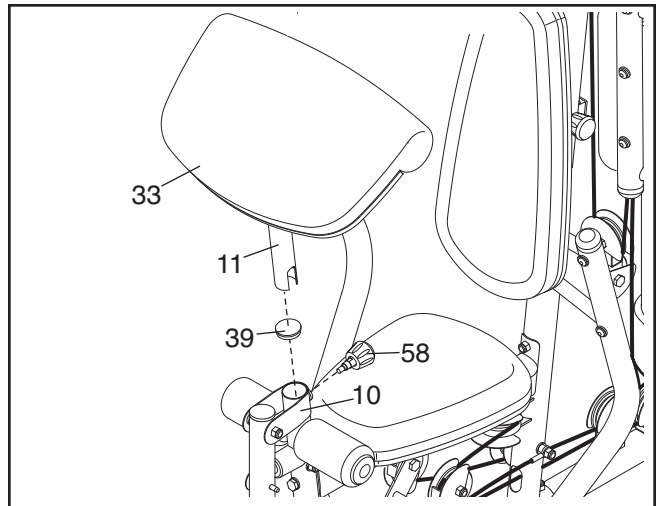

ADJUSTING THE BACKREST

The Backrest (31) can be adjusted to provide the correct position for each exercise. To adjust the Backrest, loosen but do not remove the Backrest Adjustment Knob (53) and pull it out. Move the Backrest in or out of the Upright (2). Insert the Adjustment Knob into the Upright and through the Backrest Frame (not shown). Tighten the Adjustment Knob.

The Seat (32) can be adjusted in the same manner.

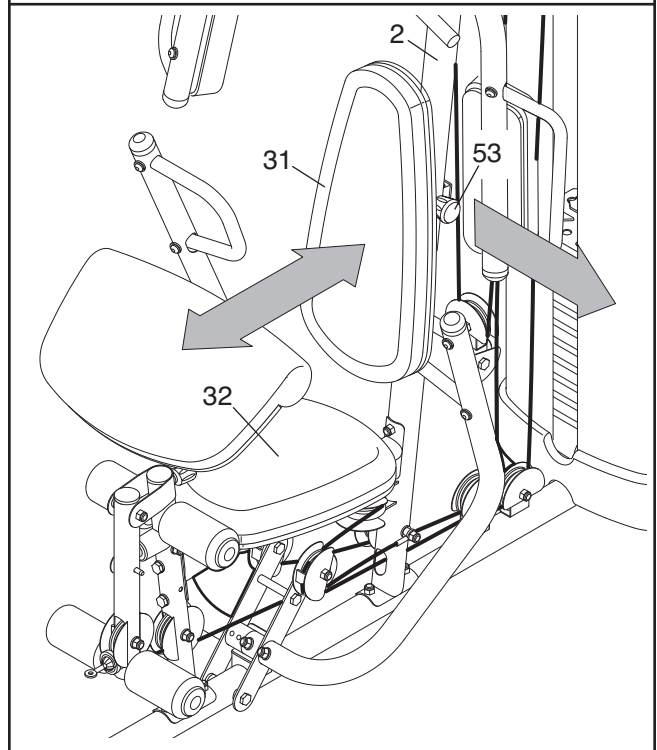

LOCKING THE WEIGHT STACK

To lock the weight stack, insert the Locking Pin (72) through one of the holes in the Guide Rods (18) and secure the Pin with the Lock (73).

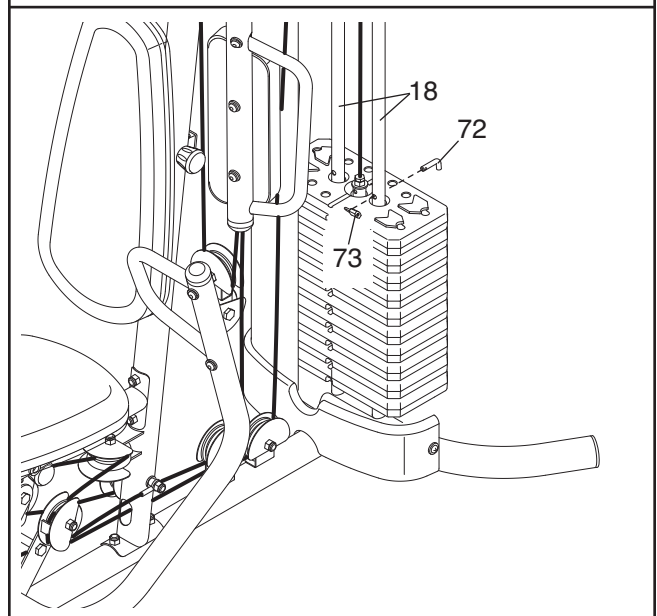

LOCKING THE LEG LEVER

To lock or unlock the Leg Lever, remove the Lock Plate Pin (95) from the Lock Plate (14). Move the Lock Plate to either the position shown on the Front Leg (10), or the indicated hole in the Leg Lever (12). Insert the Lock Pin back through the Lock Plate.

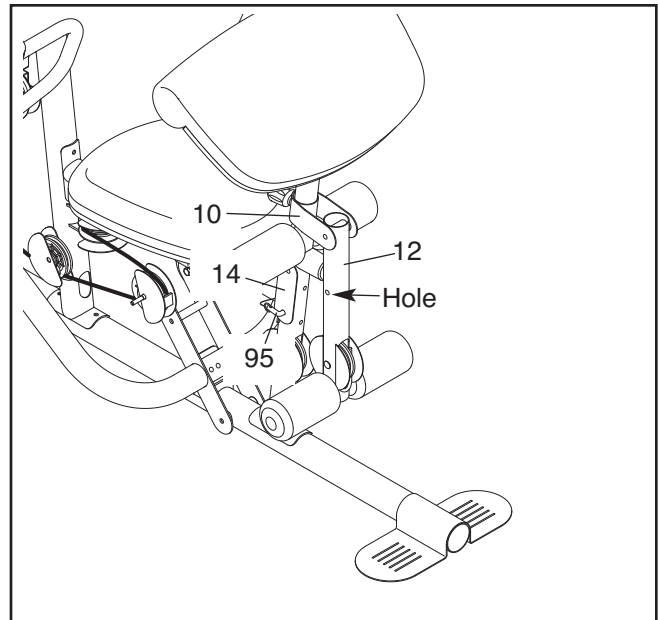

WEIGHT RESISTANCE CHART

The chart below shows the approximate weight resistance at each exercise station. Weight resistance shown for the butterfly arm station is for each arm. **Note: The actual resistance at each station may vary due to differences in individual weight plates as well as friction between the cables, pulleys, and weight guides.**

WEIGHT	HIGH PULLEY (lbs.)	BUTTERFLY ARM (lbs.)	PRESS ARM (lbs.)	LEG LEVER (lbs.)	LOW PULLEY (lbs.)
1	26	17	46	27	25
2	38	24	63	42	39
3	51	32	76	54	52
4	62	41	90	69	67
5	76	48	104	87	80
6	94	55	121	103	92
7	124	64	138	116	111
8	133	71	153	127	121
9	165	79	172	135	140
10	178	90	195	167	168

Note: 1 lb. equals .454 kg.

CABLE DIAGRAM

The cable diagram shows the proper routing of the cables (49, 50, 51). Use the diagram to make sure that the cable and the cable traps have been assembled correctly. If the cable has not been correctly routed, the weight system will not function properly and damage may occur. The numbers show the correct route for the cable. **Make sure that the cable traps do not touch or bind the cable.**

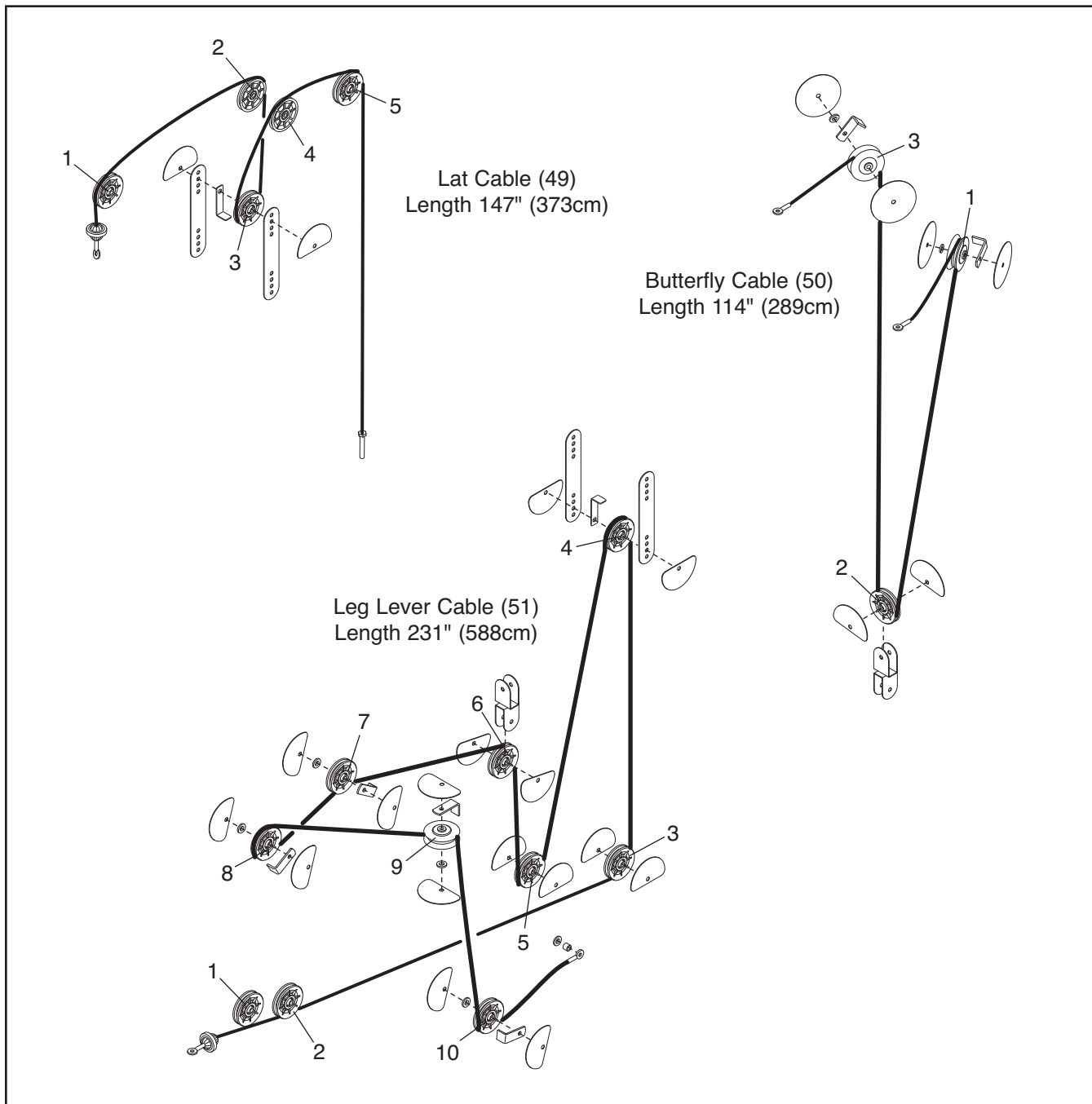

MAINTENANCE

Make sure that all parts are properly tightened each time the weight system is used. Replace any worn parts immediately. The weight system can be cleaned with a damp cloth and a mild, non-abrasive detergent. Do not use solvents.

TIGHTENING THE CABLES

Woven cable, the type of cable used on the weight system, can stretch slightly when it is first used. If there is slack in the cables before resistance is felt, the cables should be tightened. To tighten the cables, first insert the weight pin into the middle of the weight stack. Slack can be removed from these cables several ways:

See drawing 1. Remove the M10 Nylon Locknut (77) and the M10 x 50mm Bolt (97) from the Cable Trap (56), the 90mm Pulley (48), the two Half Guards (55), and the two Pulley Plates (60). Reattach the Pulley, Cable Trap, and Half Guards to the next closer hole to the center of the Pulley Plates. **Make sure that the Cable Trap is oriented to hold the cable in the groove of the Pulley, that the Half Guards are oriented as shown, and that the Cable and Pulley move smoothly.**

See drawing 2. Loosen the M12 Nut (112) on the Lat Cable (49). Tighten the Cable into the Weight Tube (not shown) until the slack is removed from the Cable. Retighten the M12 Nut against the M12 Large Washer (98).

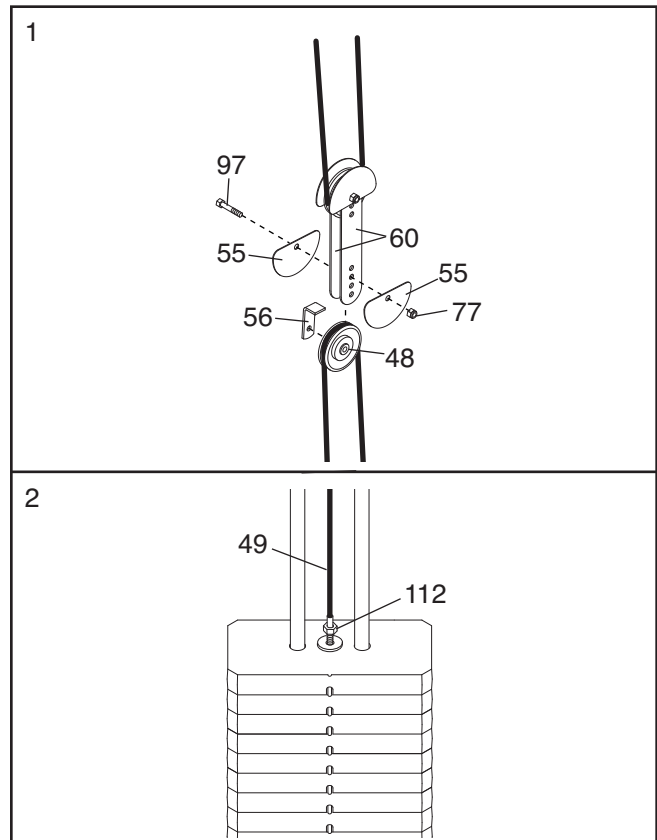

Do not overtighten the cables. If the cables are overtightened, the top weight will be lifted off the weight stack. If a cable tends to slip off the pulleys often, it may have become twisted. Remove the cable and re-install it. If the cables need to be replaced, see the part ordering information on the back cover of this manual.

EXERCISE GUIDELINES

THE FOUR BASIC TYPES OF WORKOUTS

Muscle Building

To increase the size and strength of your muscles, push them close to their maximum capacity. Your muscles will continually adapt and grow as you progressively increase the intensity of your exercise. You can adjust the intensity level of an individual exercise in two ways:

- by changing the amount of weight used
- by changing the number of repetitions or sets performed. (A “repetition” is one complete cycle of an exercise, such as one sit-up. A “set” is a series of repetitions.)

The proper amount of weight for each exercise depends upon the individual user. You must gauge your limits and select the amount of weight that is right for you. Begin with 3 sets of 8 repetitions for each exercise you perform. Rest for three minutes after each set. When you can complete 3 sets of 12 repetitions without difficulty, increase the amount of weight.

Toning

You can tone your muscles by pushing them to a moderate percentage of their capacity. Select a moderate amount of weight and increase the number of repetitions in each set. Complete as many sets of 15 to 20 repetitions as possible without discomfort. Rest for one minute after each set. Work your muscles by completing more sets rather than by using high amounts of weight.

Weight Loss

To lose weight, use a low amount of weight and increase the number of repetitions in each set. Exercise for 20 to 30 minutes, resting for a maximum of 30 seconds between sets.

Cross Training

Cross training is an efficient way to implement a complete and well-balanced fitness program. An example of a balanced program follows:

- Plan strength training workouts on Monday, Wednesday, and Friday.
- Plan 20 to 30 minutes of aerobic exercise, such as running on a treadmill or riding on an elliptical exerciser or exercise cycle, on Tuesday and Thursday.
- Rest from both strength training and aerobic exercise for at least one full day each week to give your body time to regenerate.

The combination of strength training and aerobic exercise will reshape and strengthen your body, plus develop your heart and lungs.

PERSONALIZING YOUR EXERCISE PROGRAM

Determining the appropriate length of time for each workout, and the numbers of repetitions and sets to complete, is an individual matter. It is important to avoid overexerting yourself during the first few months of your exercise program. Progress at your own pace and be sensitive to your body's signals. If you experience pain or dizziness at any time while exercising, stop immediately and begin cooling down. Find out what is wrong before continuing. Remember that adequate rest and a proper diet are important factors in any exercise program.

WARMING UP

Begin each workout with 5 to 10 minutes of stretching and light exercise to warm up. Warming up prepares your body for more strenuous exercise by increasing circulation, raising your body temperature and delivering more oxygen to your muscles.

WORKING OUT

Each workout should include 6 to 10 different exercises. Select exercises for every major muscle group, emphasizing areas that you want to develop most. To give balance and variety to your workouts, vary the exercises from session to session.

Schedule your workouts for the time of day when your energy level is the highest. Each workout should be followed by at least one day of rest. Once you find the schedule that is right for you, stick with it.

EXERCISE FORM

Maintaining proper form is an essential part of an effective exercise program. This requires moving through the full range of motion for each exercise, and moving only the appropriate parts of the body. Exercising in an uncontrolled manner will leave you feeling exhausted. On the exercise guide accompanying this manual you will find photographs showing the correct form for several exercises, and a list of the muscles affected. See the muscle chart on the next page to find the names of the muscles.

The repetitions in each set should be performed smoothly and without pausing. The exertion stage of each repetition should last about half as long as the return stage. Proper breathing is important. Exhale during the exertion stage of each repetition and inhale during the return stroke. Never hold your breath.

Rest for a short period of time after each set. The ideal resting periods follow:

- Rest for three minutes after each set for a muscle building workout.
- Rest for one minute after each set for a toning workout.
- Rest for 30 seconds after each set for a weight loss workout.

Plan to spend the first couple of weeks familiarizing yourself with the equipment and learning the proper form for each exercise.

COOLING DOWN

End each workout with 5 to 10 minutes of stretching. Include stretches for both your arms and legs. Move

slowly as you stretch and do not bounce. Ease into each stretch gradually and go only as far as you can without strain. Stretching at the end of each workout is an effective way to increase flexibility.

STAYING MOTIVATED

For motivation, keep a record of each workout. The chart on page 32 of this manual can be photocopied and used to schedule and record your workouts. List the date, the exercises performed, the weight used, and the numbers of sets and repetitions completed. Record your weight and key body measurements at the end of every month. Remember, the key to achieving the greatest results is to make exercise a regular and enjoyable part of your everyday life.

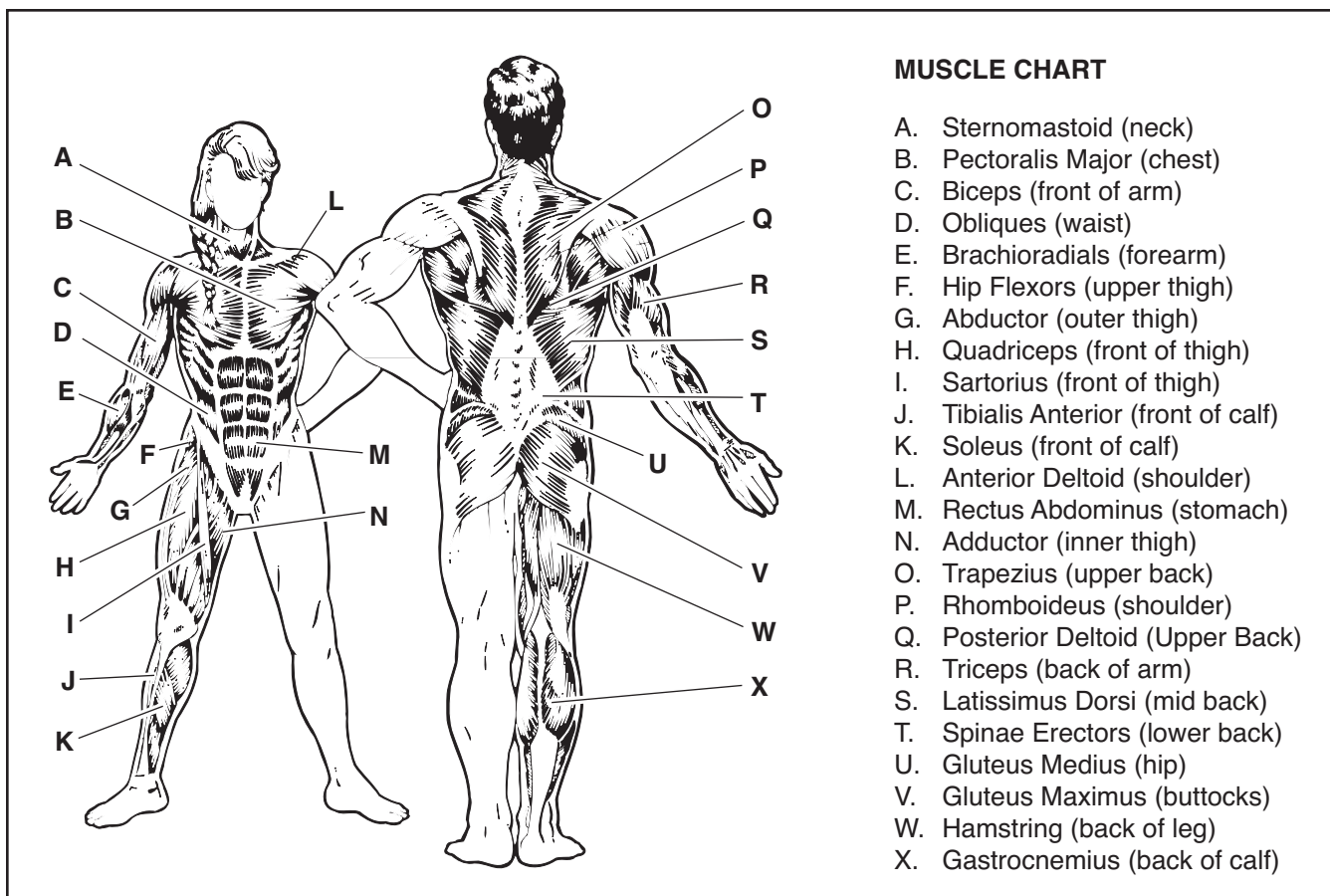

MONDAY	EXERCISE	WEIGHT	SETS	REPS
Date: / /				

TUESDAY AEROBIC EXERCISE

Date: / /

WEDNESDAY	EXERCISE	WEIGHT	SETS	REPS
Date: / /				

THURSDAY AEROBIC EXERCISE

Date: / /

FRIDAY	EXERCISE	WEIGHT	SETS	REPS
Date: / /				

Make photocopies of this page for scheduling and recording your workouts.

PART LIST—Model No. GGSY3066.0

R1006A

Key No.	Qty.	Description	Key No.	Qty.	Description	Key No.	Qty.	Description
1	1	Base			Cap	85	4	M10 x 65mm Bolt
2	1	Upright	43	2	Butterfly Arm Cap	86	4	M10 x 45mm Bolt
3	1	Stabilizer	44	2	Bolt Cap	87	1	M8 x 69mm Shoulder Bolt
4	1	Top Frame	45	4	Butterfly Arm Bushing			
5	1	Butterfly Frame	46	4	Butterfly Bracket	88	6	M6 x 20mm Screw
6	1	Butterfly Frame			Bushing	89	2	M6 x 38mm Screw
		Brace	47	3	“V”-pulley	90	2	M8 x 22mm Shoulder Bolt
7	1	Backrest Frame	48	13	90mm Pulley			
8	1	Seat Frame	49	1	Lat Cable	91	4	M6 x 65mm Button Screw
9	1	Frame	50	1	Butterfly Cable			
10	1	Front Leg	51	1	Leg Lever Cable	92	2	M10 x 82mm Button Screw
11	1	Curl Post	52	1	Seat Adjustment Knob	93	2	M10 x 110mm Bolt
12	1	Leg Lever			Backrest Adjustment Knob	94	4	M6 x 28mm Bolt
13	2	Pad Tube	53	1	Guard	95	1	Lock Plate Pin
14	1	Lock Plate			Half Guard	96	1	M10 x 155mm Bolt
15	1	Left Press Arm	54	4	Cable Trap	97	4	M10 x 50mm Bolt
16	1	Right Press Arm	55	20	Long Cable Trap	98	1	M12 Large Washer
17	2	Press Arm Handle	56	5	Curl Adjustment Knob	99	8	11mm Spacer
18	2	Weight Guide	57	3	89.5mm Spacer	100	8	M8 x 80mm Bolt
19	10	Weight	58	1	Pulley Plate	101	2	M8 x 65mm Bolt
20	1	Weight Tube	59	2	Double “U”-Bracket	102	13	M4 x 12mm Self-tapping Screw
21	1	Left Shroud	60	2	Ankle Strap	103	11	M8 Washer
22	1	Right Shroud	61	1	Lat Bar	104	9	M4 Washer
23	2	Shroud Cover	62	1	Hand Grip	105	2	M10 Large Washer
24	2	21mm Steel Spacer	63	1	Handle	106	6	M10 x 65mm Button Bolt
25	1	Left Butterfly Arm	64	2	Weight Clip			
26	1	Right Butterfly Arm	65	1	19mm Spacer	107	4	M6 Nylon Locknut
27	2	Butterfly Handle	66	2	25mm Bushing	108	1	M10 x 70mm Bolt
28	1	Left Butterfly Bracket	67	6	56.5mm Spacer	109	10	13mm Steel Spacer
29	1	Right Butterfly Bracket	68	4	Weight Pin	110	9	M4 x 16mm Self-tapping Screw
		Butterfly Cover	69	1	Weight Bumper			
30	1	Backrest	70	1	Lock Pin	111	1	7mm Spacer
31	1	Seat	71	2	Lock	112	1	M12 Nut
32	1	Curl Pad	72	1	16mm Bushing	113	2	Thin Pulley
33	1	Left Butterfly Pad	73	1	Leg Lever Bumper	114	14	M6 Washer
34	1	Right Butterfly Pad	74	8	Weight Tube Cap	115	1	M10 x 120mm Bolt
35	1	Foam Pad	75	1	M10 Nylon Locknut	116	1	M10 x 61mm Bolt Set
36	4	Pad Cap	76	1	M8 Nylon Locknut	117	1	Chain
37	4	63.5mm Round Inner Cap	77	35	M10 x 60mm Bolt	118	1	M10 x 75mm Button Screw
38	5	50mm Round Inner Cap	78	18	M10 Washer			
		Cap	79	2	M10 x 85mm Bolt	#	–	User’s Manual
39	3	Press Arm Cap	80	35	M10 x 75mm Bolt	#	–	Exercise Guide
40	2	40mm x 20mm Inner Cap	81	2	M8 x 75mm Carriage Bolt	#	–	Hex Key
41	4	40mm x 25mm Inner Cap	82	2	M10 x 80mm Bolt	#	–	Grease Packet
42	2		83	5				
			84	5				

Note: “#” indicates a non-illustrated part. Specifications are subject to change without notice. See the back cover of this manual for information about ordering replacement parts.

EXPLODED DRAWING—Model No. GGSY3066.0

R1006A

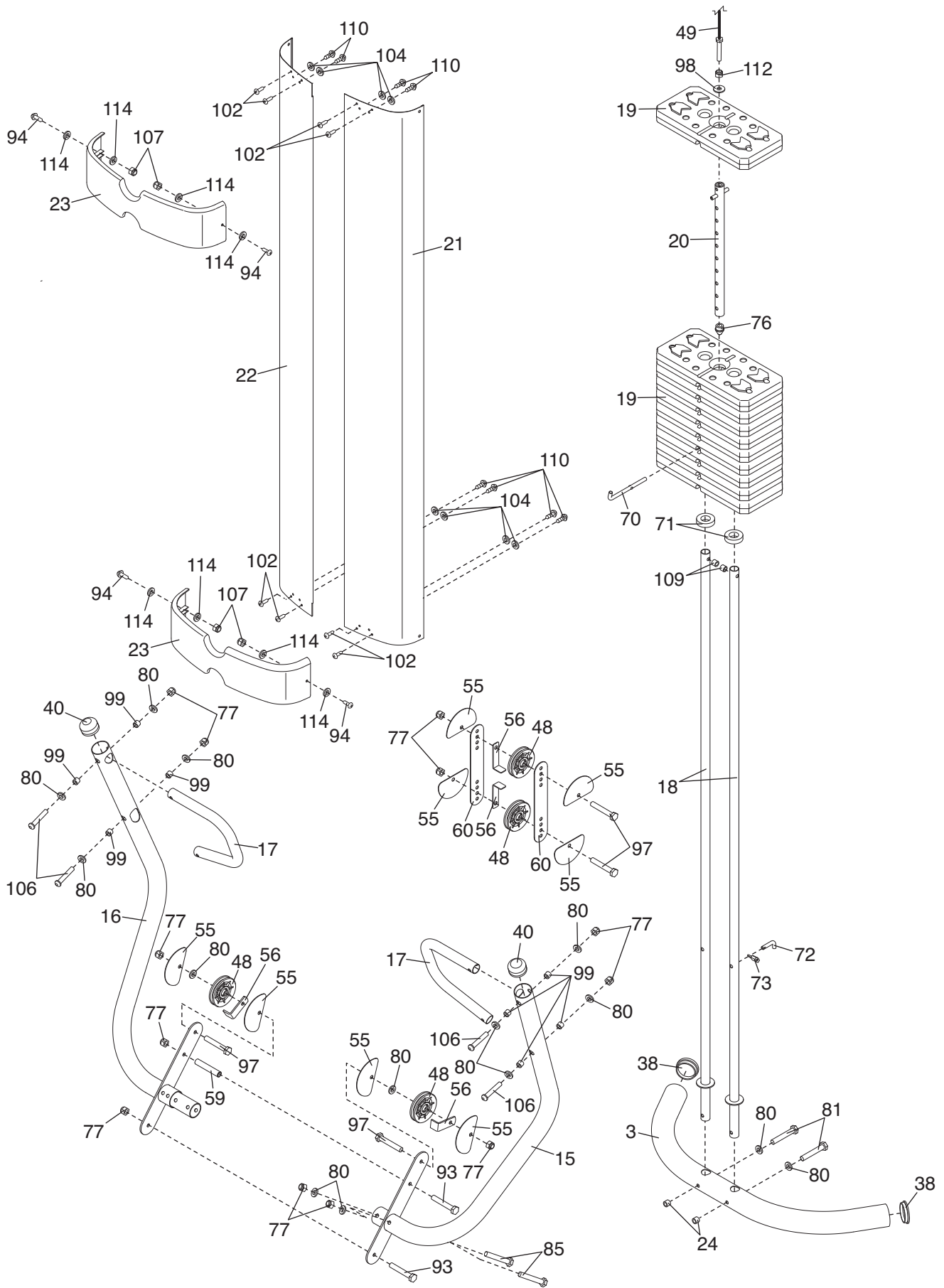

EXPLODED DRAWING—Model No. GGSY3066.0

R1006A

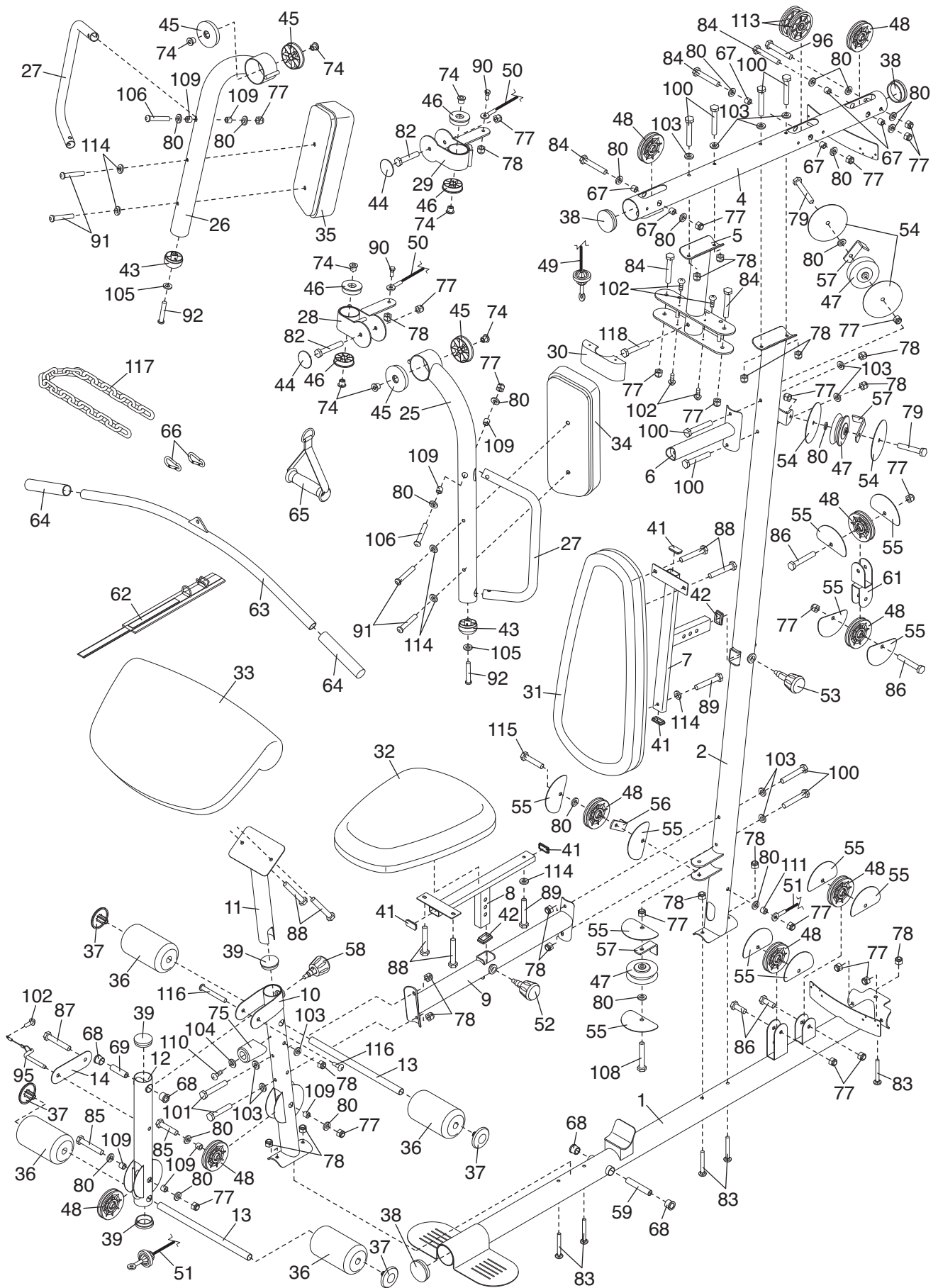

ORDERING REPLACEMENT PARTS

To order replacement parts, please see the front cover of this manual. To help us assist you, be prepared to provide the following information:

- the MODEL NUMBER of the product (GGSY3066.0)
- the NAME of the product (GOLD'S GYM GS2700 POWERGLIDE weight system)
- the SERIAL NUMBER of the product (see the front cover of this manual)
- the KEY NUMBER and DESCRIPTION of the part(s) (see the PART LIST and the EXPLODED DRAWING on pages 33 to 35)

LIMITED WARRANTY

ICON Health & Fitness, Inc. (ICON) warrants this product to be free from defects in workmanship and material, under normal use and service conditions, for a period of ninety (90) days from the date of purchase. This warranty extends only to the original purchaser. ICON's obligation under this warranty is limited to replacing or repairing, at ICON's option, the product through one of its authorized service centers. All repairs for which warranty claims are made must be preauthorized by ICON. If the product is shipped to a service center, freight charges to and from the service center will be the customer's responsibility. For in-home service, the customer will be responsible for a minimal trip charge. This warranty does not extend to any product or damage to a product caused by or attributable to freight damage, abuse, misuse, improper or abnormal usage or repairs not provided by an ICON authorized service center; products used for commercial or rental purposes; or products used as store display models. No other warranty beyond that specifically set forth above is authorized by ICON.

ICON is not responsible or liable for indirect, special or consequential damages arising out of or in connection with the use or performance of the product or damages with respect to any economic loss, loss of property, loss of revenues or profits, loss of enjoyment or use, costs of removal or installation or other consequential damages of whatsoever nature. Some states do not allow the exclusion or limitation of incidental or consequential damages. Accordingly, the above limitation may not apply to you.

The warranty extended hereunder is in lieu of any and all other warranties and any implied warranties of merchantability or fitness for a particular purpose is limited in its scope and duration to the terms set forth herein. Some states do not allow limitations on how long an implied warranty lasts. Accordingly, the above limitation may not apply to you.

This warranty gives you specific legal rights. You may also have other rights which vary from state to state.

ICON HEALTH & FITNESS, INC., 1500 S. 1000 W., LOGAN, UT 84321-9813