

GOLD'S GYM[®] XR66

Model No. GGSY69530

Serial No. _____

Write the serial number in the space above for future reference.

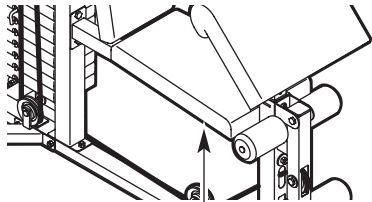

Serial Number Decal (Under Seat)

USER'S MANUAL

QUESTIONS?

As a manufacturer, we are committed to providing complete customer satisfaction. If you have questions, or if there are missing or damaged parts, we will guarantee complete satisfaction through direct assistance from our factory.

TO AVOID DELAYS, PLEASE CALL DIRECT TO OUR TOLL-FREE CUSTOMER HOT LINE. The trained technicians on our customer hot line will provide immediate assistance, free of charge.

CUSTOMER HOT LINE:
1-800-999-3756
Mon.-Fri., 6 a.m.-6 p.m.
MST

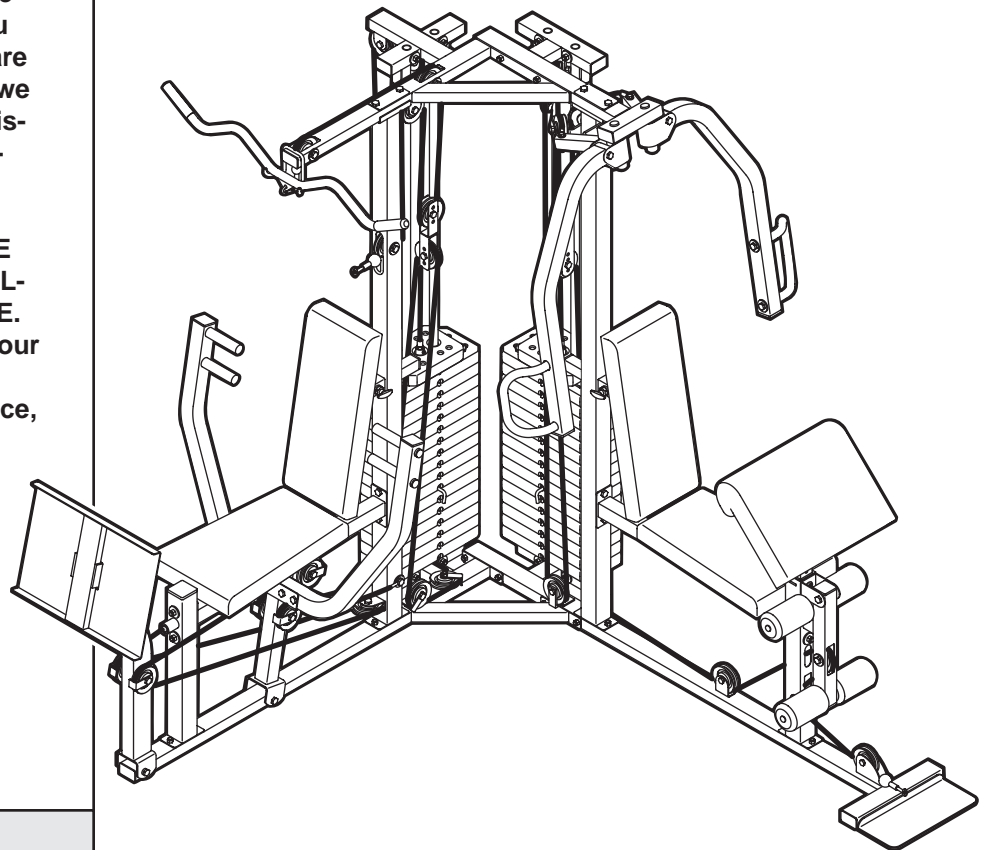

CAUTION

Read all precautions and instructions in this manual before using this equipment. Save this manual for future reference.

TABLE OF CONTENTS

WARNING DECAL PLACEMENT	.2
IMPORTANT PRECAUTIONS	.3
BEFORE YOU BEGIN	.4
ASSEMBLY	.5
ADJUSTMENTS	.23
WEIGHT RESISTANCE CHART	.25
TROUBLESHOOTING	.26
CABLE DIAGRAMS	.27
EXERCISE GUIDELINES	.29
ORDERING REPLACEMENT PARTS	.Back Cover
LIMITED WARRANTY	.Back Cover

Note: A PART IDENTIFICATION CHART, a PART LIST, and an EXPLODED DRAWING are attached in the center of this manual. Remove the PART IDENTIFICATION CHART, PART LIST, and EXPLODED DRAWING before beginning assembly.

WARNING DECAL PLACEMENT

The decal shown here has been placed on the weight system in the indicated locations. If the decal is missing or illegible, call our toll-free Customer Hot Line at 1-800-999-3756 and order a free replacement decal. Apply the decal in the location shown.

⚠ WARNING

- Misuse of this product may result in serious injury.
- Read user's manual and follow all warnings and operating instructions prior to use.
- Do not allow children on or around machine.
- Replace label if damaged, illegible, or removed.

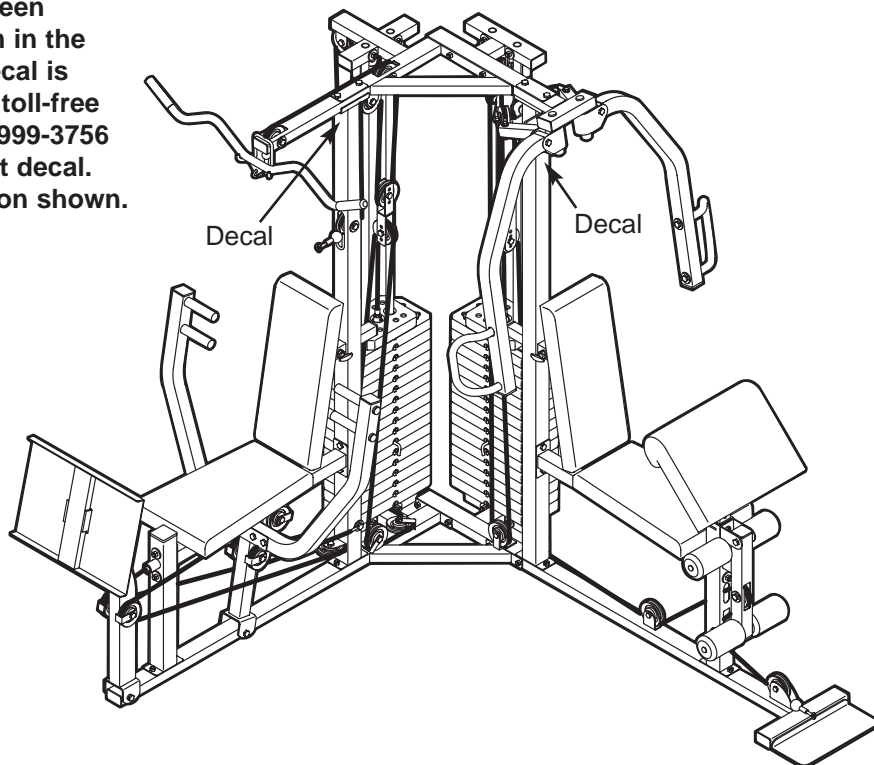

GOLD'S GYM is a registered trademark of Gold's Gym International, Inc. This product is manufactured and distributed under license from Gold's Gym Merchandising, Inc.

IMPORTANT PRECAUTIONS

⚠️ WARNING: To reduce the risk of serious injury, read the following important precautions before using the weight system.

1. Read all instructions in this manual and in the accompanying literature before using the weight system.
2. It is the responsibility of the owner to ensure that all users of the weight system are adequately informed of all precautions.
3. The weight system is intended for home use only. Do not use the weight system in any commercial, rental, or institutional setting.
4. Use the weight system only on a level surface. Cover the floor beneath the weight system to protect the floor.
5. Make sure that all parts are properly tightened each time the weight system is used. Replace any worn parts immediately.
6. Keep children under 12 and pets away from the weight system at all times.
7. Keep hands and feet away from moving parts.
8. Always wear athletic shoes for foot protection.
9. The weight system is designed to support a maximum user weight of 300 pounds.
10. The weight system should not be used by more than one person at a time.
11. Always stand on the foot plate when performing an exercise that could cause the weight system to tip.
12. Never release the butterfly arms, leg lever, press arm, leg press arm, lat bar, ab strap, or ankle strap while weights are raised. The weights will fall with great force.
13. *Always disconnect the lat bar from the weight system when performing an exercise that does not use the lat bar.*
14. Make sure that the cables remain on the pulleys at all times. If the cables bind while you are exercising, stop immediately and make sure that the cables are on all of the pulleys.
15. If you feel pain or dizziness while exercising, stop immediately and begin cooling down.

⚠️ WARNING: Before beginning this or any exercise program, consult your physician. This is especially important for persons over the age of 35 or persons with pre-existing health problems. Read all instructions before using. ICON assumes no responsibility for personal injury or property damage sustained by or through the use of this product.

BEFORE YOU BEGIN

Thank you for selecting the versatile GOLD'S GYM® XR66 weight system. The weight system offers a selection of weight stations designed to develop every major muscle group of the body. Whether your goal is to tone your body, build dramatic muscle size and strength, or improve your cardiovascular system, the weight system will help you to achieve the specific results you want.

For your benefit, read this manual carefully before using the weight system. If you have questions after reading this manual, please call our Customer Service

Department toll-free at 1-800-999-3756, Monday through Friday, 6 a.m. until 6 p.m. Mountain Time (excluding holidays). To help us assist you, please note the product model number and serial number before calling. The model number is GGSY69530. The serial number can be found on a decal attached to the weight system (see the front cover of this manual).

Before reading further, please review the drawing below and familiarize yourself with the parts that are labeled.

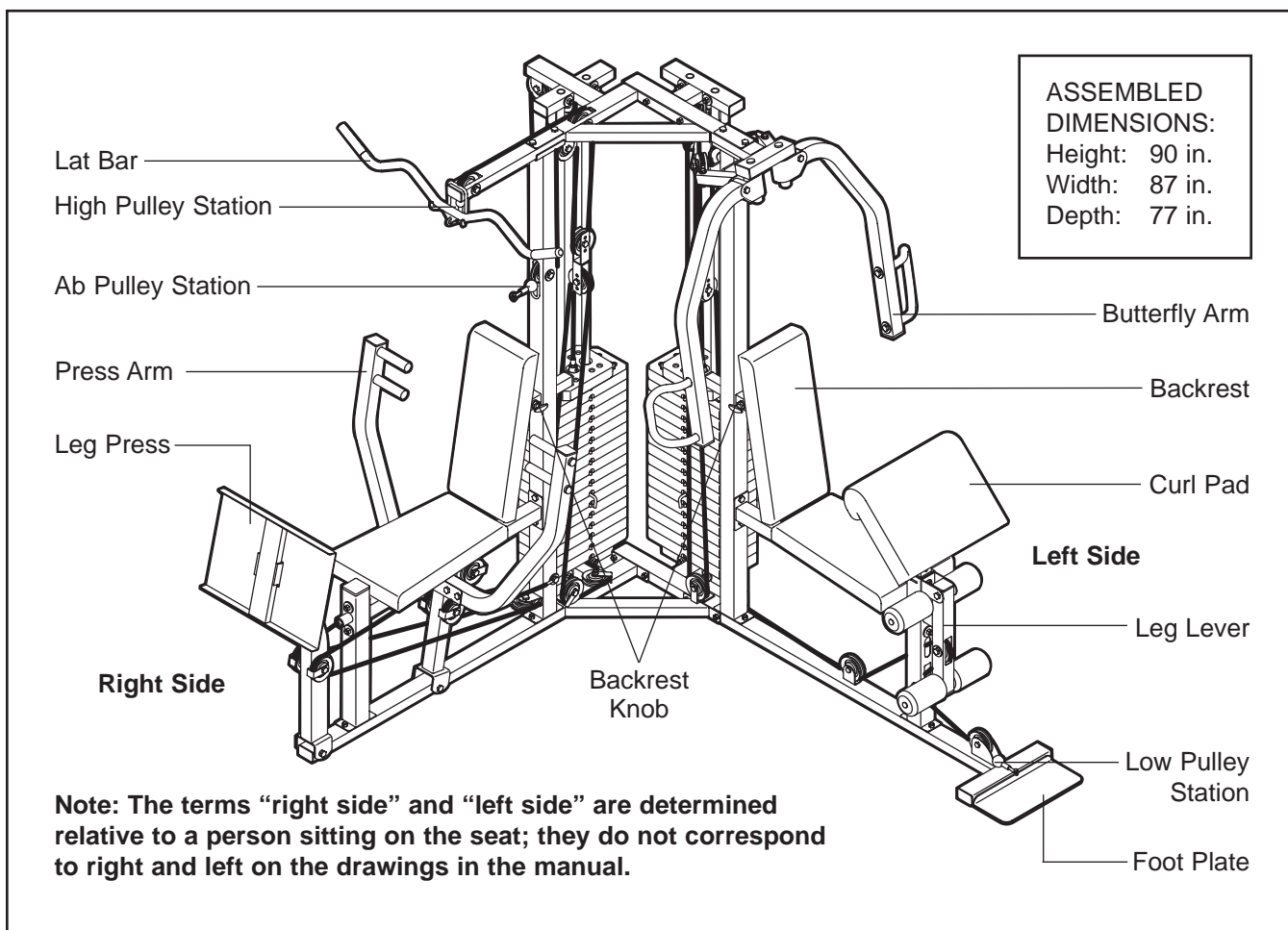

ASSEMBLY

Make Assembly Easier for Yourself

Everything in this manual is designed to ensure that the weight system can be assembled successfully by anyone. **Before beginning assembly, make sure to read the information on this page. This brief introduction will save you much more time than it takes to read it.**

Assembly Requires Two Persons

For your convenience and safety, assemble the weight system with the help of another person.

Set Aside Enough Time

Due to the many features of the weight system, the assembly process will require several hours. By setting aside plenty of time and by deciding to make the task enjoyable, assembly will go smoothly. You may want to assemble the weight system over a couple of evenings.





Select a Location for the Weight System

Because of its weight and size, the weight system should be assembled in the location where it will be used. Make sure that there is enough room to walk around the weight system as you assemble it.

How to Unpack the Box

To make assembly as easy as possible, we have divided the assembly process into four stages. The parts needed for each stage are found in individual bags. **Important: Wait until you begin each stage to open the parts bag for that stage.** Place all parts of the weight system in a cleared area and remove the packing materials. Do not dispose of the packing materials until assembly is completed.

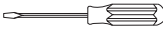
Make sure you have the following tools:

- Two adjustable wrenches 
- One standard screwdriver 
- One phillips screwdriver 
- One rubber mallet 
- You will also need grease or petroleum jelly, a small amount of soapy water, and clear tape or masking tape.

Note: Assembly will be more convenient if you have a socket set, a set of open-end or closed-end wrenches, or a set of ratchet wrenches.

How to Identify Parts

To help you identify the small parts used in assembly, we have included a **PART IDENTIFICATION CHART** in the center of this manual. Place the chart on the floor and use it to easily identify parts during each assembly step. **Note: Some small parts may have been pre-attached. If a part is not in the parts bag, check to see if it has been pre-attached.**

How to Orient Parts

As you assemble the weight system, make sure that all parts are oriented exactly as shown in the drawings.

Tightening Parts

Tighten all parts as you assemble them, unless instructed to do otherwise.

Questions?

If you have questions after reading the assembly instructions, please call our Customer Service Department at **1-800-999-3756**.

The Four Stages of the Assembly Process

Frame Assembly—You will begin by assembling the base and the uprights that form the skeleton of the weight system.

Arm Assembly—During this stage you will assemble the arms and the leg lever.

Cable Assembly—During this stage you will attach the cables and pulleys that connect the arms to the weights.

Seat Assembly—During the final stage you will assemble the seats and the backrests.

Frame Assembly

1. Before beginning assembly, make sure you understand the information in the box on page 5.

Locate and open the parts bags labeled “FRAME ASSEMBLY 1” and “FRAME ASSEMBLY 2.”

Press four 40mm x 60mm Inner Caps (42) into the Right Base (1).

Insert four M10 x 53mm Carriage Bolts (83) and an M10 x 78mm Carriage Bolt (84) up through the Right Base (1). **Note: It may be helpful to place tape over the heads of the Carriage Bolts to hold them in place.**

2. Press five 40mm x 60mm Inner Caps (42) into the Left Base (2).

Insert four M10 x 53mm Carriage Bolts (83) up through the Left Base (2). **Note: It may be helpful to place tape over the heads of the Carriage Bolts to hold them in place.**

3. Attach the Right Base (1) to the Left Base (2) with four M10 x 78mm Bolts (85), four M10 Washers (74), and four M10 Nylon Locknuts (75). **Do not tighten the Locknuts yet.**

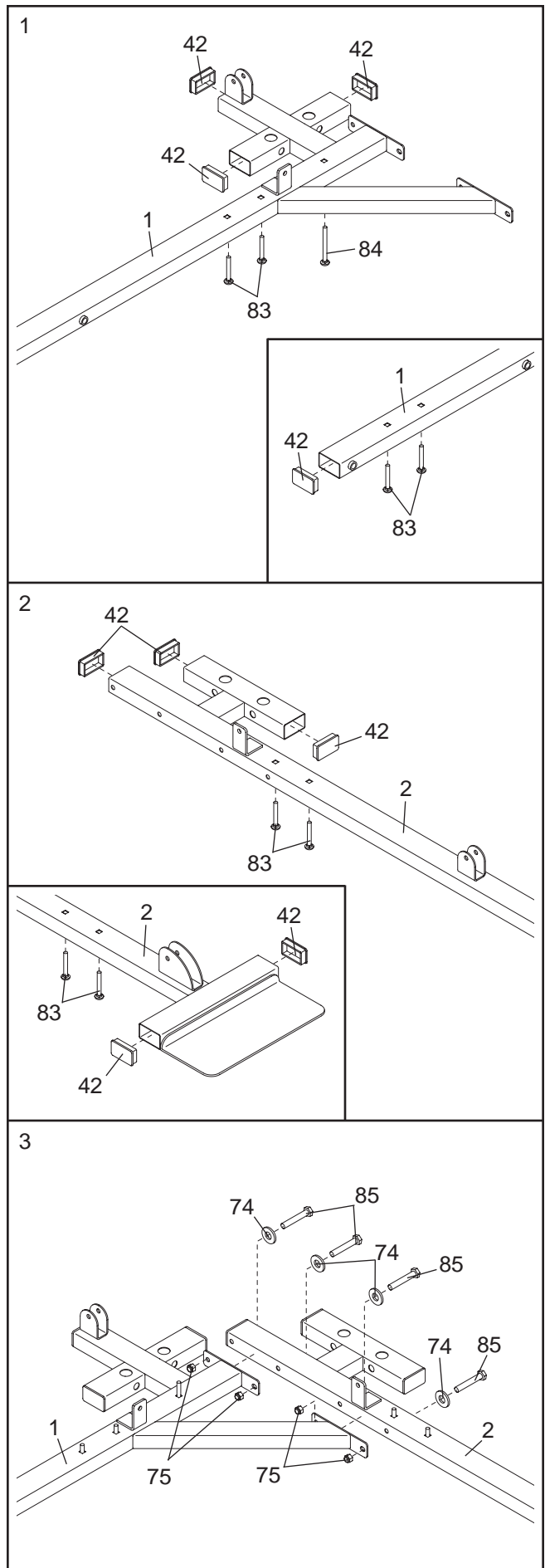

4. Attach the Right Upright (5) to the Right Base (1) with the indicated two M10 x 53mm Carriage Bolts (83) and two M10 Nylon Locknuts (75). **Do not tighten the Locknuts yet.**

Attach the Left Upright (6) to the Left Base (2) with the indicated two M10 x 53mm Carriage Bolts (83) and two M10 Nylon Locknuts (75). **Do not tighten the Locknuts yet.**

Attach two Backrest Knobs (48) to the Right and Left Uprights (5, 6).

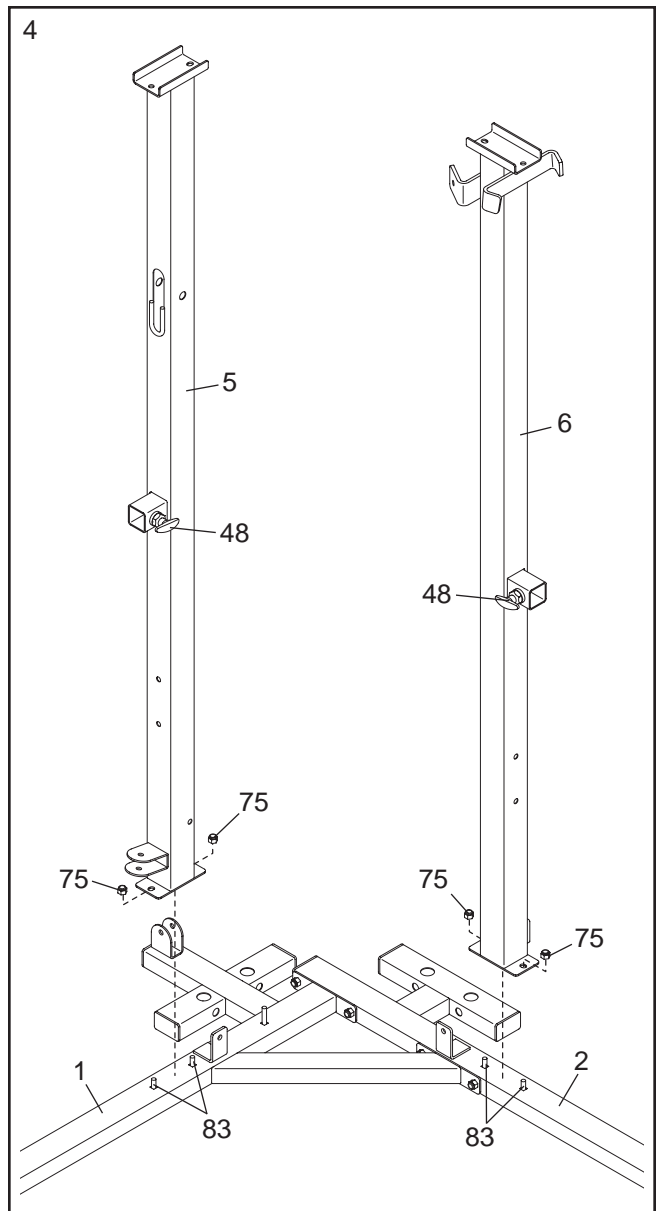

5. Press a 60mm Square Inner Cap (46) into the Right Leg (7). Attach a Leg Bumper (49) to the Right Leg with an M4 x 25mm Self-tapping Screw (77) and an M4 Washer (93).

Attach the Right Leg (7) to the Right Base (1) with the indicated two M10 x 53mm Carriage Bolts (83) and two M10 Nylon Locknuts (75). **Do not tighten the Locknuts yet.**

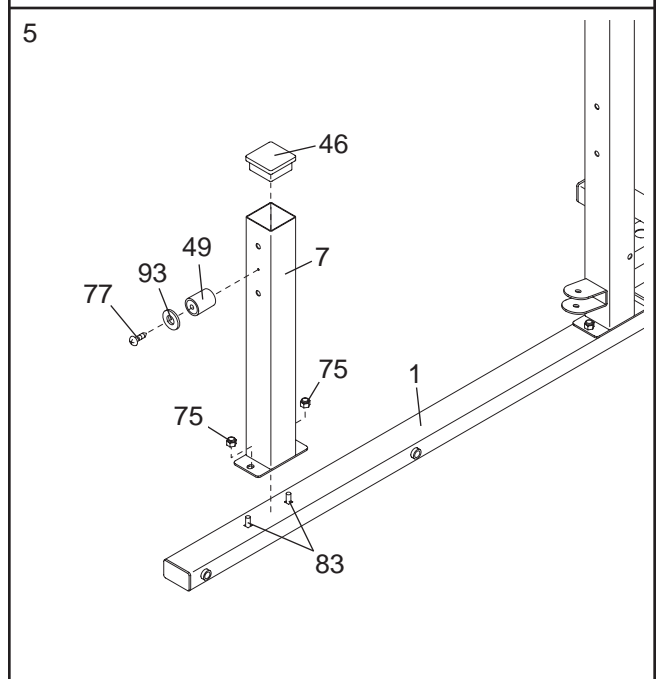

- Press a 50mm x 75mm Inner Cap (45) into the Right Seat Frame (3).

Attach the Right Seat Frame (3) to the Right Leg (7) with two M10 x 80mm Bolts (86), two M10 Large Washers (94), and two M10 Nylon Locknuts (75). **Do not tighten the Locknuts yet.**

Attach the Right Seat Frame (3) to the Right Upright (5) with two M10 x 80mm Bolts (86), two M10 Large Washers (94), and two M10 Nylon Locknuts (75). **Do not tighten the Locknuts yet.**

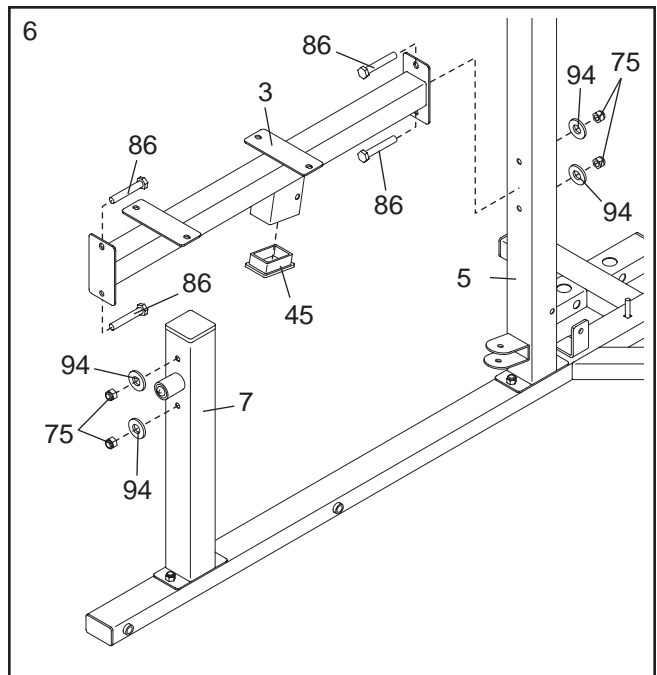

- Attach a Leg Bumper (49) to the Left Leg (8) with an M4 x 25mm Self-tapping Screw (77) and an M4 Washer (93).

Attach the Left Leg (8) to the Left Base (2) with the indicated two M10 x 53mm Carriage Bolts (83) and two M10 Nylon Locknuts (75). **Do not tighten the Locknuts yet.**

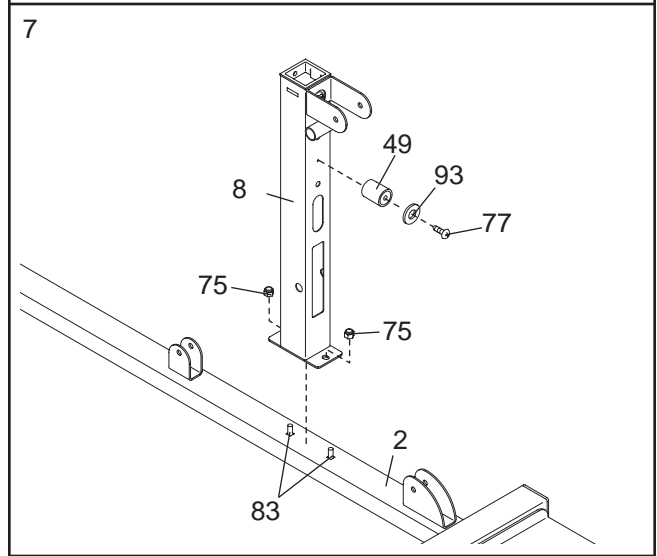

- Orient the Left Seat Frame (4) as shown. **Make sure the brackets are closer to the Left Leg (8).** Attach the Left Seat Frame to the Left Leg with two M10 x 80mm Bolts (86), two M10 Large Washers (94), and two M10 Nylon Locknuts (75). **Do not tighten the Locknuts yet.**

Attach the Left Seat Frame (4) to the Left Upright (6) with two M10 x 80mm Bolts (86), two M10 Large Washers (94), and two M10 Nylon Locknuts (75). **Do not tighten the Locknuts yet.**

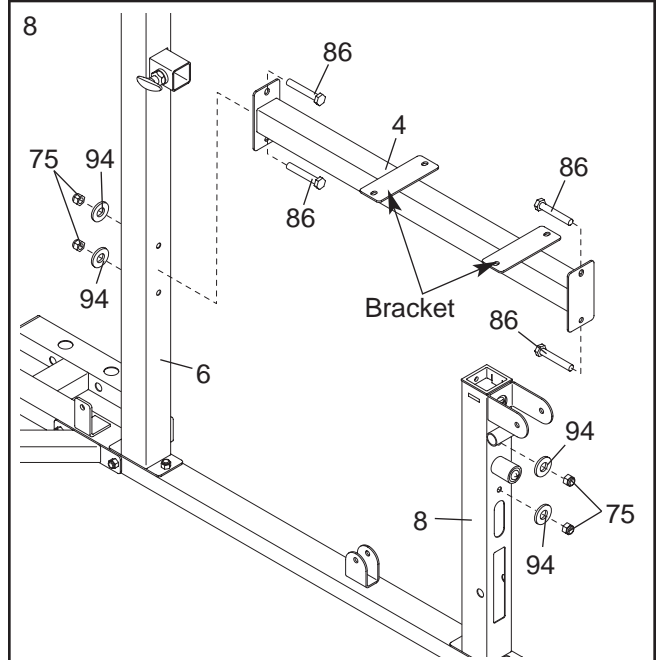

9. Slide two Weight Bumpers (50) onto two Weight Guides (9) as shown.

Attach the Weight Guides (9) to the Left Base (2) with two M10 x 78mm Bolts (85), four M10 Washers (74), four 17mm Spacers (58), and two M10 Nylon Locknuts (75).

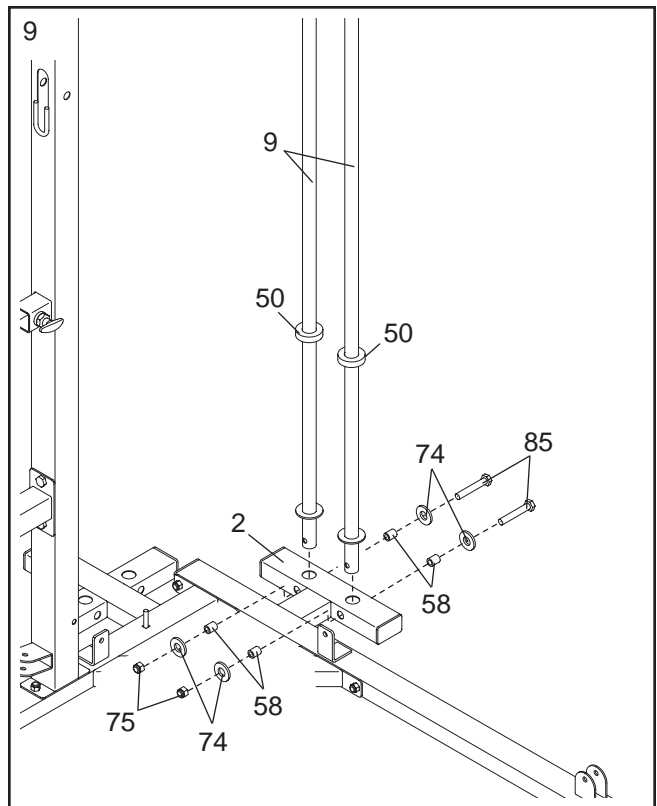

10. Slide sixteen Weights (30) onto the Weight Guides (9). **Make sure the slots for the Weight Pin (not shown) are on the indicated side and on the bottom of the Weights.**

Press a Weight Tube Bumper (35) into a Weight Tube (34). Insert the Weight Tube into the stack of Weights (30) as shown.

Lubricate the indicated holes in a Top Weight (31) with grease. Slide the Top Weight onto the Weight Guides (9). **Make sure that the groove on the Top Weight for the Weight Tube (34) pin is on the bottom of the Top Weight.**

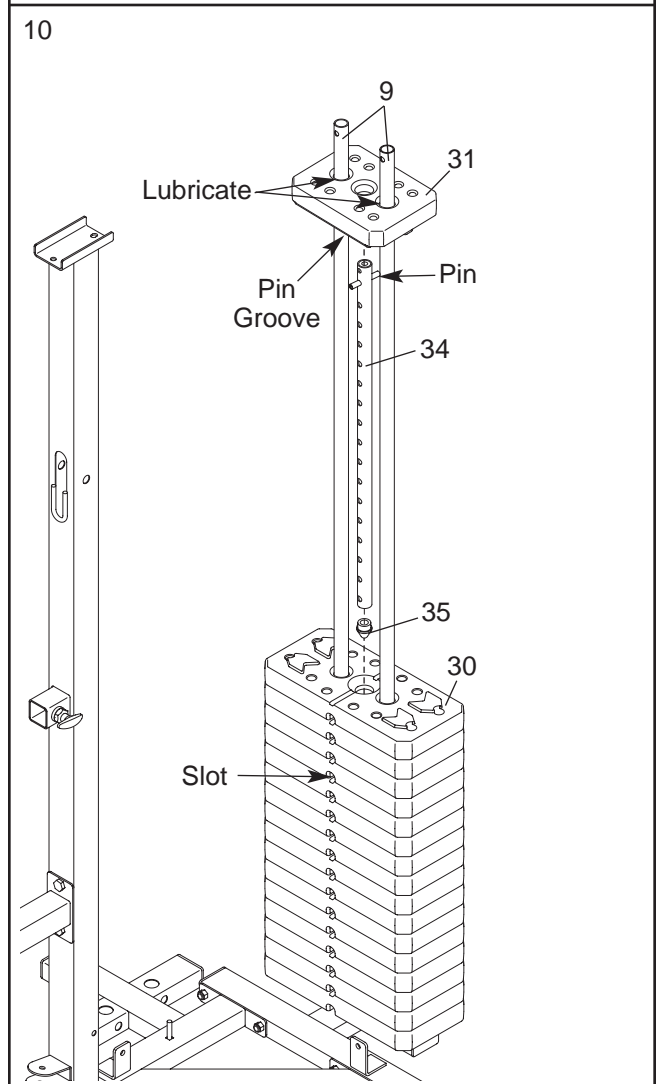

11. Press three 40mm x 60mm Inner Caps (42) into the Left Top Frame (11). Press two 40mm x 60mm Thick Inner Caps (91) into the Left Top Frame. Press two 25mm Round Outer Caps (47) onto the Left Top Frame.

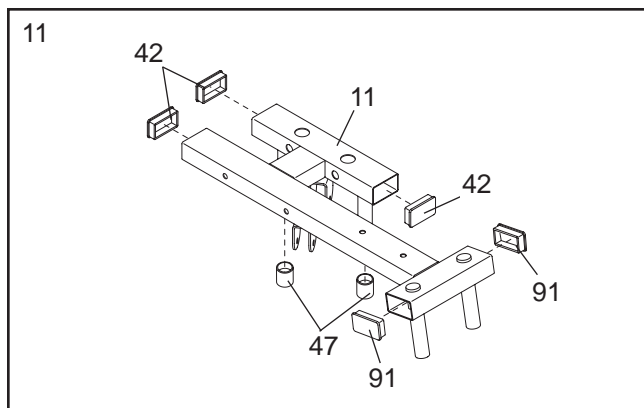

12. Attach the Left Top Frame (11) to the Weight Guides (9) with two M10 x 78mm Bolts (85), four M10 Washers (74), four 17mm Spacers (58), and two M10 Nylon Locknuts (75). **Do not tighten the Locknuts yet.**

Attach the Left Top Frame (11) to the Left Upright (6) with two M10 x 60mm Bolts (82), a Support Plate (29), and two M10 Nylon Locknuts (75). **Do not tighten the Locknuts yet.**

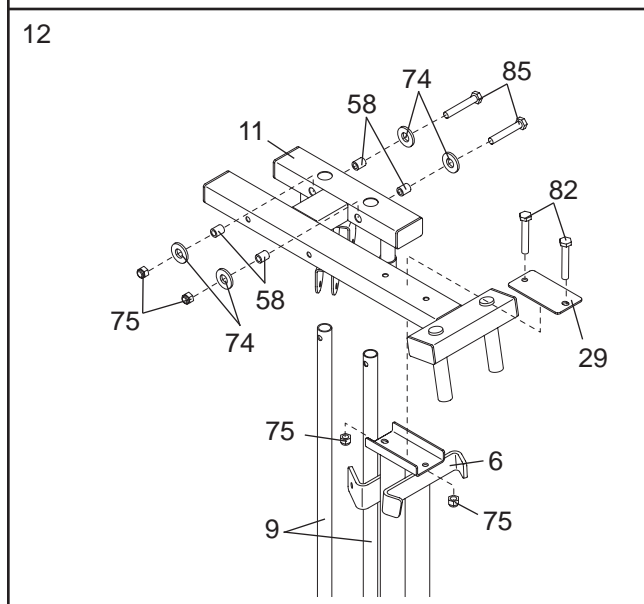

13. Slide two Weight Bumpers (50) onto the other two Weight Guides (9).

Attach the Weight Guides (9) to the Right Base (1) with two M10 x 78mm Bolts (85), four M10 Washers (74), four 17mm Spacers (58), and two M10 Nylon Locknuts (75).

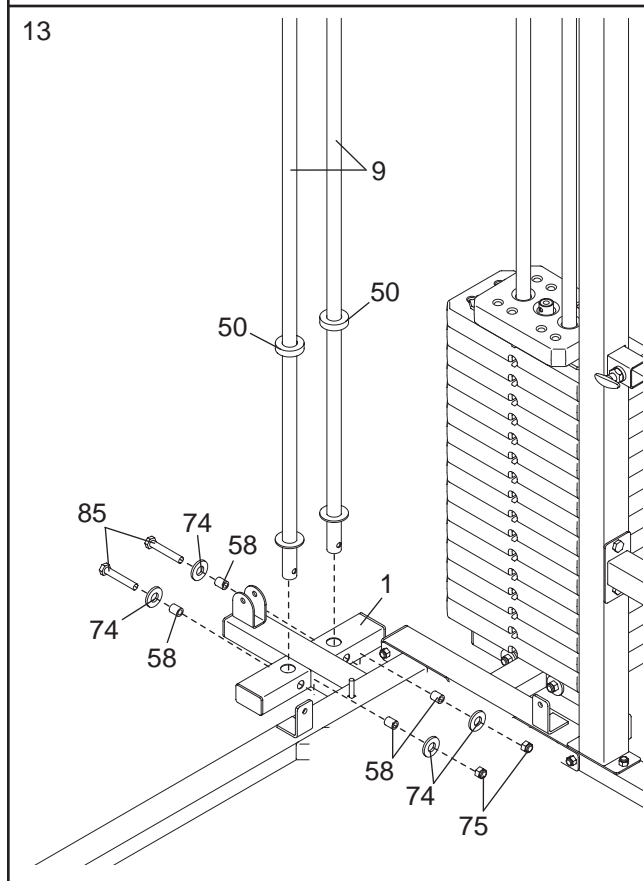

14. Slide sixteen Weights (30) onto the Weight Guides (9). **Make sure the slots for the Weight Pin (not shown) are on the indicated side and on the bottom of the Weights.**

Press a Weight Tube Bumper (35) into a Weight Tube (34). Insert the Weight Tube into the stack of Weights (30) as shown.

Lubricate the indicated holes in a Top Weight (31) with grease. Slide the Top Weight onto the Weight Guides (9). **Make sure that the groove on the Top Weight for the Weight Tube (34) pin is on the bottom of the Top Weight.**

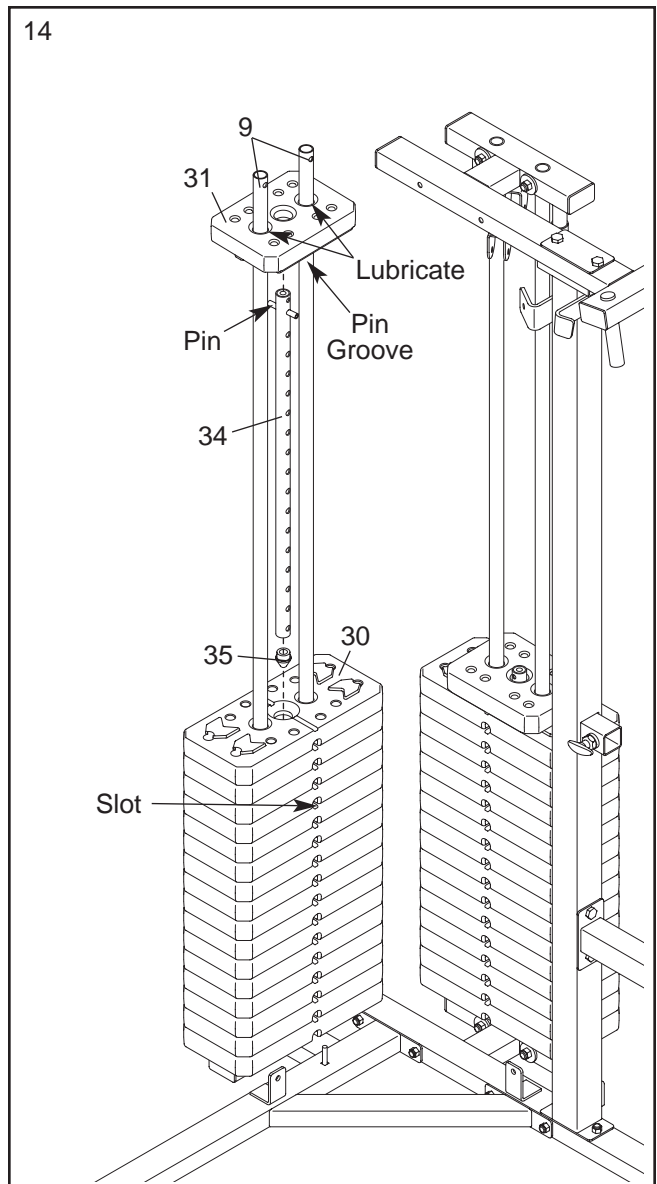

15. Press four 40mm x 60mm Inner Caps (42) into the Right Top Frame (10). Press two 25mm Round Outer Caps (47) onto the Right Top Frame.

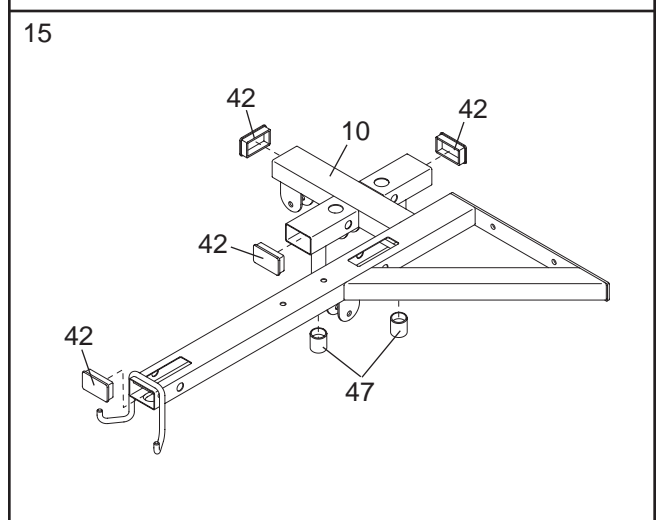

16. Attach the Right Top Frame (10) to the Weight Guides (9) with two M10 x 78mm Bolts (85), four M10 Washers (74), four 17mm Spacers (58), and two M10 Nylon Locknuts (75). **Do not tighten the Locknuts yet.**

Attach the Right Top Frame (10) to the Right Upright (5) with two M10 x 60mm Bolts (82), a Support Plate (29), and two M10 Nylon Locknuts (75). **Do not tighten the Locknuts yet.**

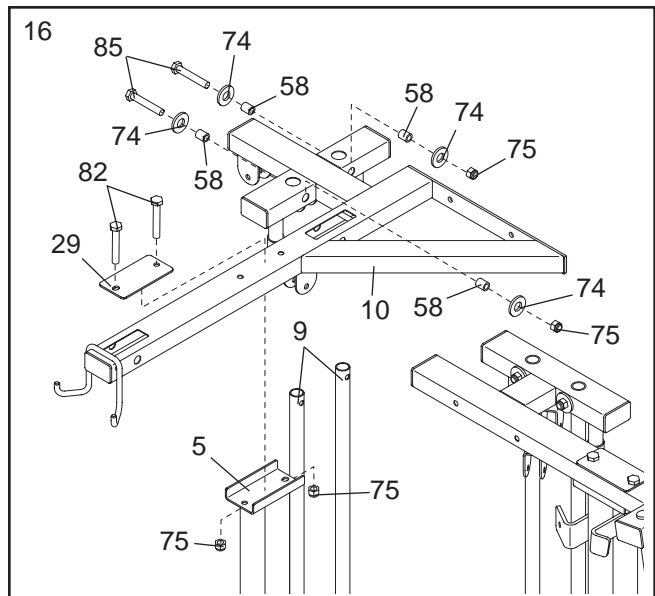

17. Attach the Right Top Frame (10) to the Left Top Frame (11) with two M10 x 80mm Bolts (86), two M10 Washers (74), and two M10 Nylon Locknuts (75).

Tighten the M10 Nylon Locknuts (75) used in steps 3–17.

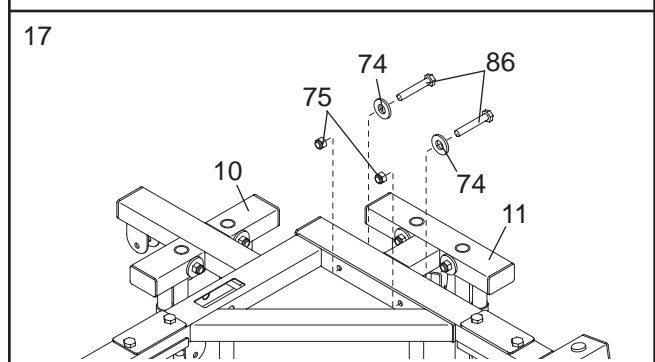

Arm Assembly

18. Open the part bag labeled “ARM ASSEMBLY.”

Press a 50mm x 75mm Inner Cap (45) into the Leg Press Arm (12).

Lubricate an M12 x 102mm Bolt (81) with grease. Attach the Leg Press Arm (12) to the Right Base (1) with the Bolt and an M12 Nylon Locknut (95).

Do not overtighten the Locknut; the Leg Press Arm must be able to pivot easily.

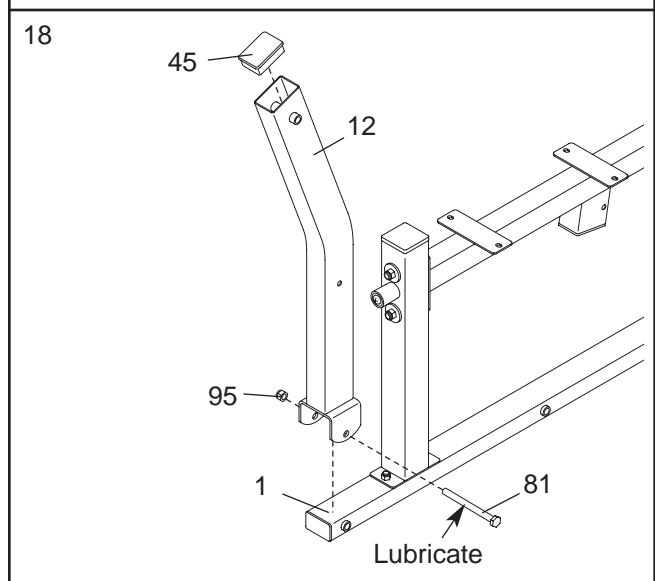

19. Lubricate an M12 x 104mm Bolt (67) with grease. Attach the Leg Press Plate (13) to the Leg Press Arm (12) with the Bolt and an M12 Nylon Locknut (95). **Make sure the bar is closer to the ground. Do not overtighten the Locknut; the Leg Press Plate must be able to pivot easily.**

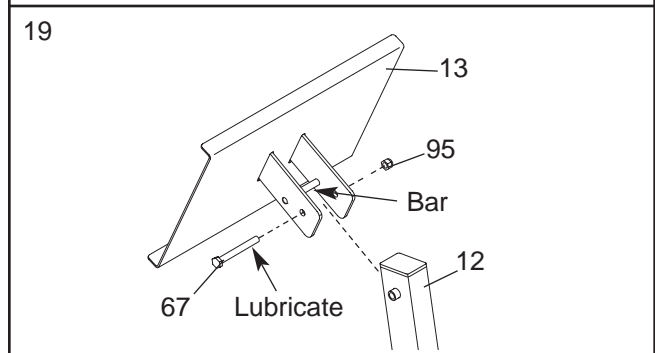

20. Lubricate an M12 x 102mm Bolt (81) with grease. Attach the Press Frame (14) to the Right Base (1) with the Bolt and an M12 Locknut (95). **Make sure the hole is closer to the indicated side of the Press Frame. Do not overtighten the Locknut; the Press Frame must be able to pivot easily.**

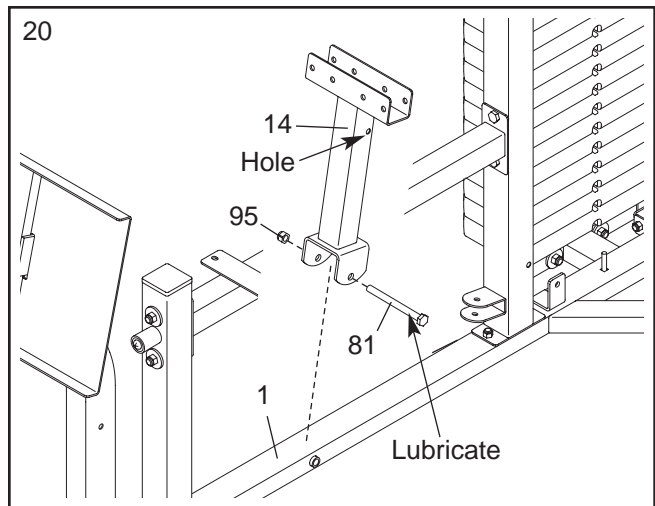

21. Press a 50mm Square Inner Cap (43) into a Press Arm (15). Press two 25mm Round Inner Caps (65) into the Press Arm.

Wet the handles on the Press Arm (15) with soapy water. Slide two Grips (68) onto the handles.

Attach the Press Arm (15) to the Press Frame (14) with two M10 x 70mm Bolts (87) and two M10 Nylon Locknuts (75).

Attach the other Press Arm (15) to the Press Frame (14) in the same manner.

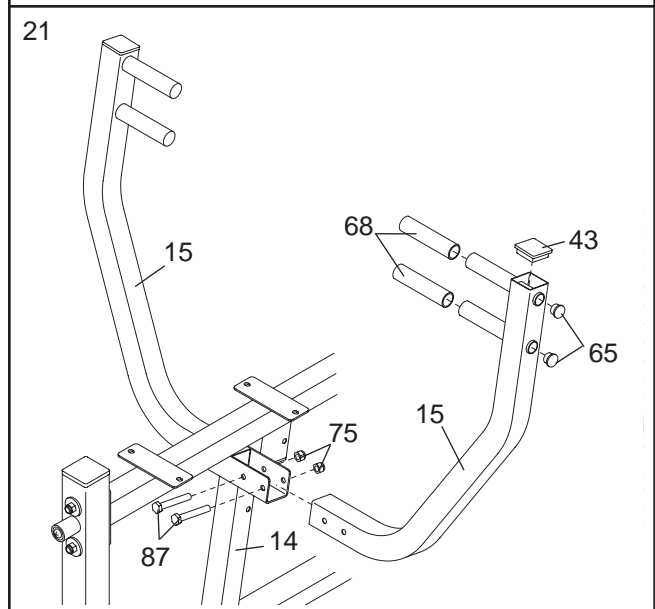

22. Press two 50mm Square Inner Caps (43) into the Leg Lever (18).

Lubricate an M10 x 78mm Bolt (85) with grease. Orient the Leg Lever (18) as shown and attach it to the Left Leg (8) with the Bolt and an M10 Nylon Locknut (75). **Do not overtighten the Locknut; the Leg Lever must be able to pivot easily.**

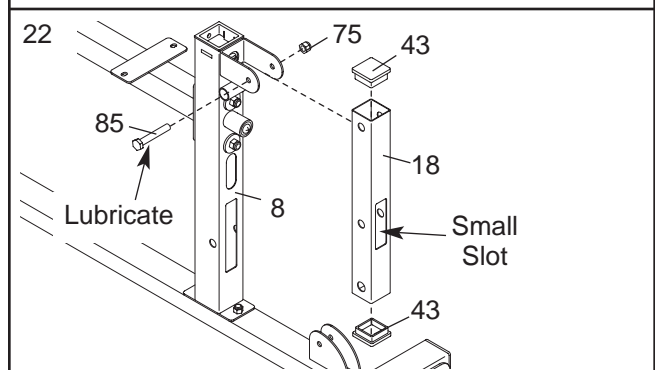

23. Lubricate both axles on the Left Top Frame (11) with grease.

Slide the Left Fly Pivot (21) onto the indicated axle on the Left Top Frame (11). Set two 25mm Retainer Rings (53) on a 25mm Round Outer Cap (47). **Make sure the teeth on the Rings are toward the Cap, as shown in the inset drawing.** Tap the Retainer Rings and Outer Cap onto the axle. **Repeat with the Right Fly Pivot (22).**

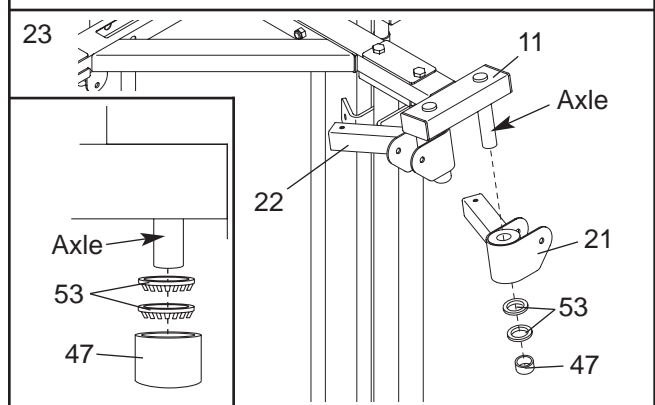

24. Press a 50mm Square Inner Cap (43) into a Butterfly Arm (20).

Wet a Fly Handle (66) and the inside of a Long Foam Pad (97) with soapy water. Slide the Foam Pad onto the Handle.

Attach a Fly Handle (66) to the Butterfly Arm (20) with two M10 x 25mm Button Screws (60) and two M10 Washers (74).

Repeat this step with the other Butterfly Arm (not shown). Make sure that the Fly Handle is oriented as shown in step 25.

25. Lubricate an M10 x 80mm Bolt (86) with grease. Attach the left Butterfly Arm (20) to the Left Fly Pivot (21) with the Bolt and an M10 Nylon Locknut (75).

Attach the right Butterfly Arm (20) to the Right Fly Pivot (22) in the same manner.

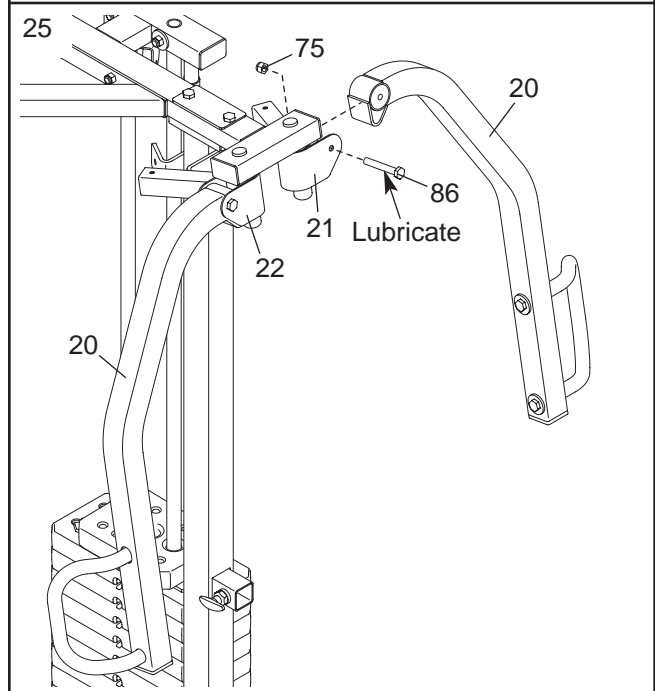
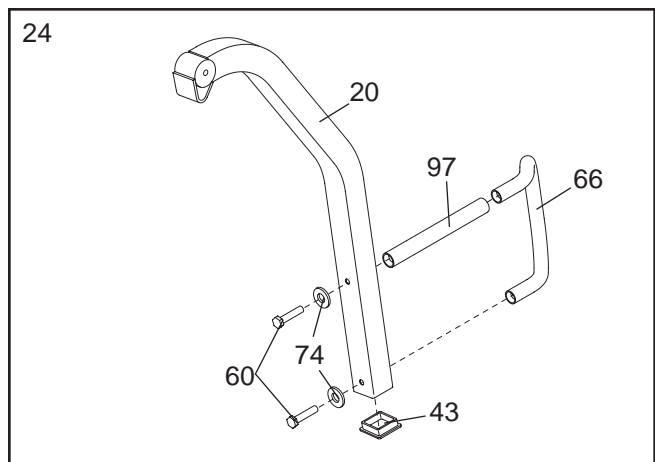

Cable Assembly

26. **IMPORTANT:** Refer to the CABLE DIAGRAMS on pages 27 and 28 for help identifying the cables.

Locate the Butterfly Cable (64). Attach the Cable to the Left Fly Pivot (21) with an M8 x 58mm Shoulder Bolt (89), two M8 Washers (90), and an M8 Nylon Locknut (54).

27. Wrap the Butterfly Cable (64) over a “V”-pulley (40). Attach the “V”-pulley and a Large Cable Trap (39) to the bracket on the Left Upright (6) with an M10 x 60mm Bolt (82) and an M10 Nylon Locknut (75). **Make sure that the Cable Trap is turned to hold the Cable in the groove of the “V”-pulley.**

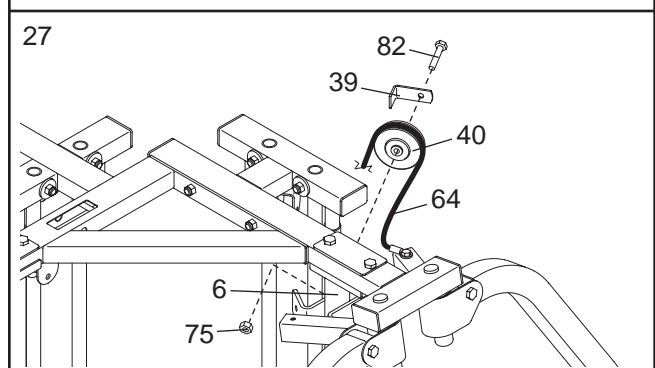
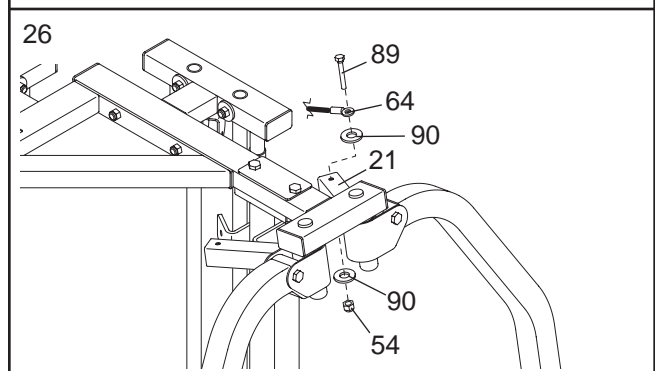

28. Wrap the Butterfly Cable (64) under a 90mm Pulley (38). Attach the Pulley and a Cable Trap (37) between the second set of holes from the top of the two Pulley Plates (36) with an M10 x 48mm Bolt (23) and an M10 Nylon Locknut (75). **Make sure that the Cable Trap is turned to hold the Cable in the groove of the Pulley.**

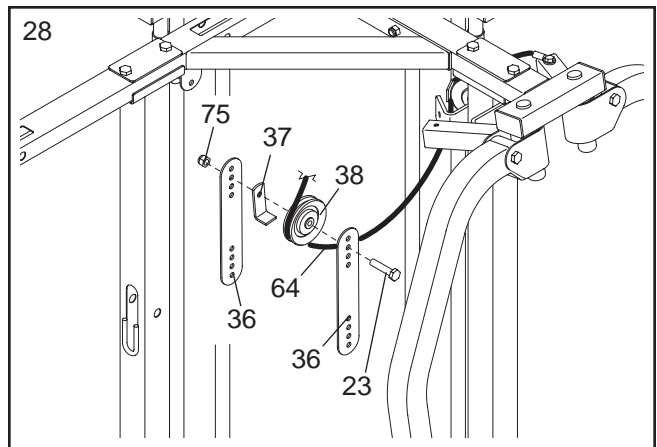

29. Wrap the Butterfly Cable (64) over a "V"-pulley (40). Attach the "V"-pulley and a Large Cable Trap (39) to the bracket on the Left Upright (6) with an M10 x 60mm Bolt (82) and an M10 Nylon Locknut (75). **Make sure that the Cable Trap is turned to hold the Cable in the groove of the "V"-pulley.**

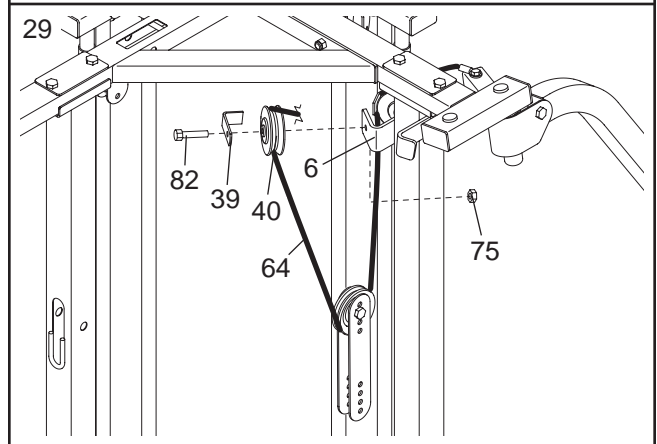

30. Attach the Butterfly Cable (64) to the Right Fly Pivot (22) with an M8 x 58mm Shoulder Bolt (89), two M8 Washers (90), and an M8 Nylon Locknut (54).

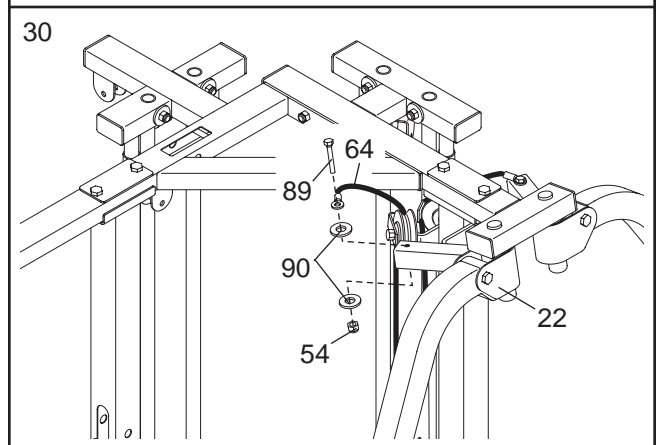

31. **Locate the Low Cable (63).** Route the Cable under a 90mm Pulley (38). Attach the Pulley inside the bracket on the Left Base (2) with an M10 x 45mm Bolt (78) and an M10 Nylon Locknut (75).

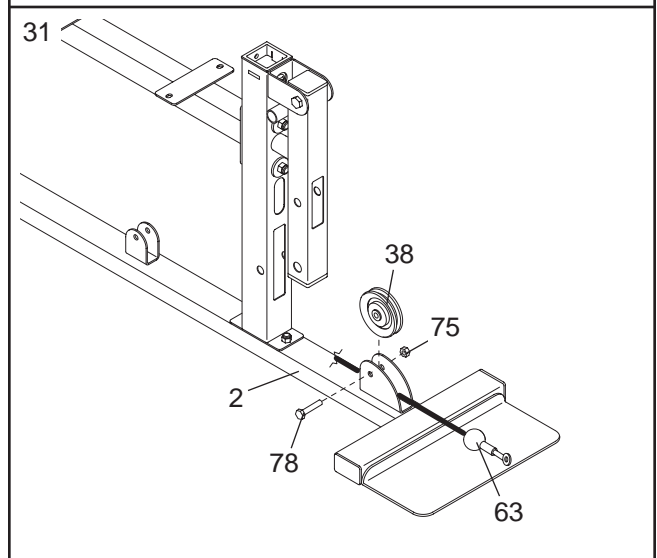

32. Wrap the Low Cable (63) around a 90mm Pulley (38). Attach the Pulley inside the Left Leg (8) with an M10 x 78mm Bolt (85), two M10 Washers (74), two 17mm spacers (58), and an M10 Nylon Locknut (75).

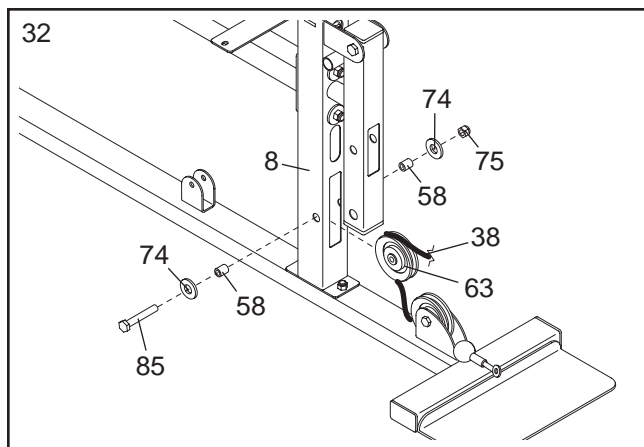

33. Route the Low Cable (63) through the Leg Lever (18), around a 90mm Pulley (38), and back through the Leg Lever and Left Leg (8). Attach the Pulley inside the Leg Lever with an M10 x 67mm Bolt (92), two M10 Washers (74), two 12mm Spacers (57), and an M10 Nylon Locknut (75).

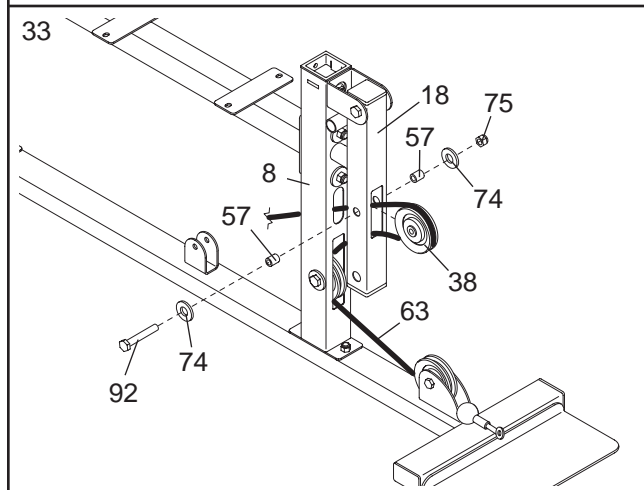

34. Wrap the Low Cable (63) under a 90mm Pulley (38). Attach the Pulley to the Left Base (2) with an M10 x 45mm Bolt (78) and an M10 Nylon Locknut (75).

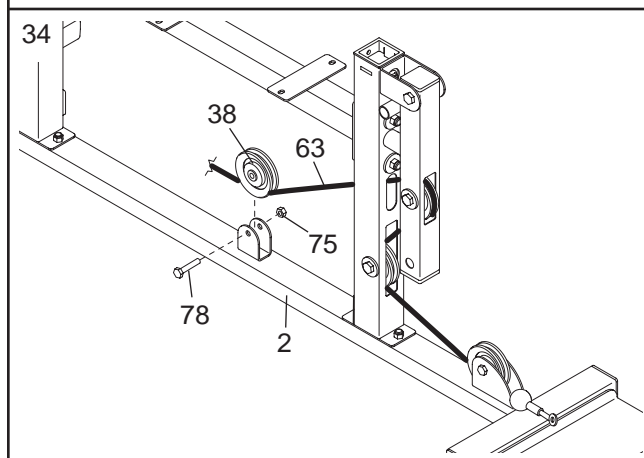

35. Wrap the Low Cable (63) under a 90mm Pulley (38). Attach the Pulley and a Cable Trap (37) to the indicated bracket on the Left Upright (6) with an M10 x 48mm Bolt (23) and an M10 Nylon Locknut (75). **Make sure the Cable Trap is oriented to hold the Cable in the groove of the Pulley.**

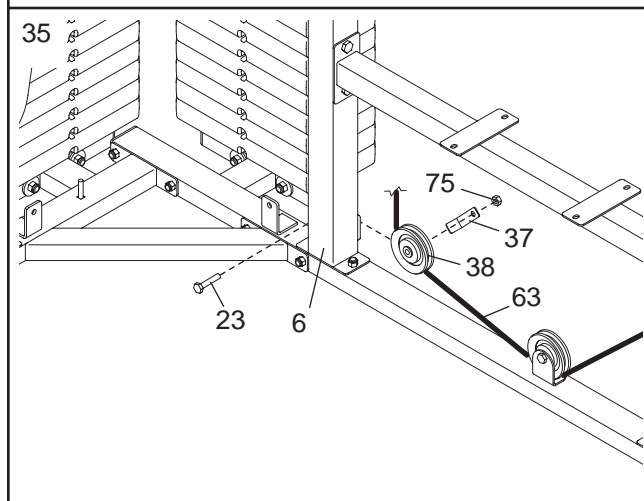

36. Wrap the Low Cable (63) over a 90mm Pulley (38). Attach the Pulley and a Cable Trap (37) between the second set of holes from the bottom of the two Pulley Plates (36) with an M10 x 48mm Bolt (23) and an M10 Nylon Locknut (75). **Make sure that the Cable Trap is turned to hold the Cable in the groove of the Pulley.**

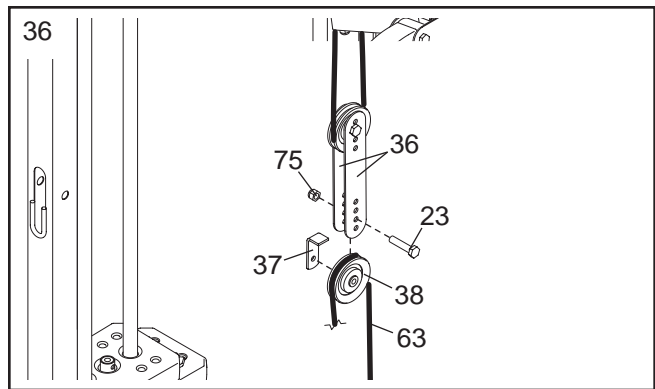

37. Wrap the Low Cable (63) under a 90mm Pulley (78). Attach the Pulley and a Cable Trap (37) to the Left Base (2) with an M10 x 48mm Bolt (23) and an M10 Nylon Locknut (75). **Make sure that the Cable Trap is turned to hold the Cable in place.**

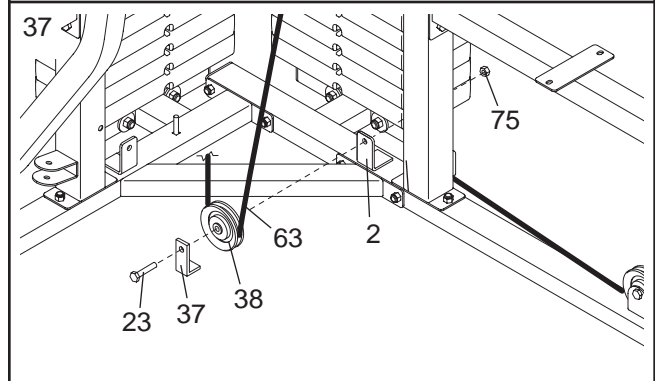

38. Wrap the Low Cable (63) over a 90mm Pulley (38). Attach the Pulley to the bracket (bracket 1) on the Left Top Frame (11) with an M10 x 45mm Bolt (78) and an M10 Nylon Locknut (75).

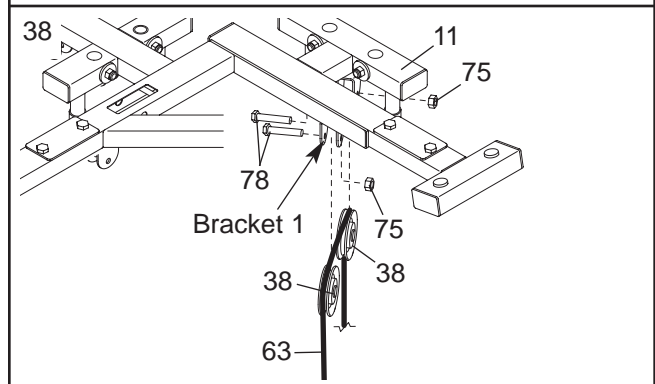

Wrap the Low Cable (63) over another 90mm Pulley (38). Attach the Pulley to the other bracket on the Left Top Frame (11) with an M10 x 45mm Bolt (78) and an M10 Nylon Locknut (75).

39. Thread an M12 Nut (80) onto the Low Cable (63) as far as it will go. Slide a 50mm Washer (59) onto the Cable and thread the Cable into the left Weight Tube (34) until the Cable is tight. Tighten the Nut against the Washer. **Do not overtighten the Cable into the Weight Tube or the Top Weight (31) will be lifted off the weight stack.**

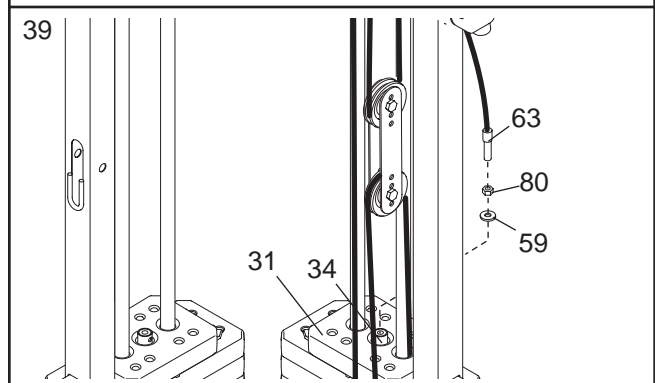

40. **Locate the High Cable (61).** Route the small ball on the Cable (61) through the Right Upright (5) and under a 90mm Pulley (38). **Make sure the Cable is over the welded bar inside the Upright.** Attach the Pulley inside the Upright with an M10 x 78mm Bolt (85), two M10 Washers (74), two 17mm Spacer (58), and an M10 Nylon Locknut (75).

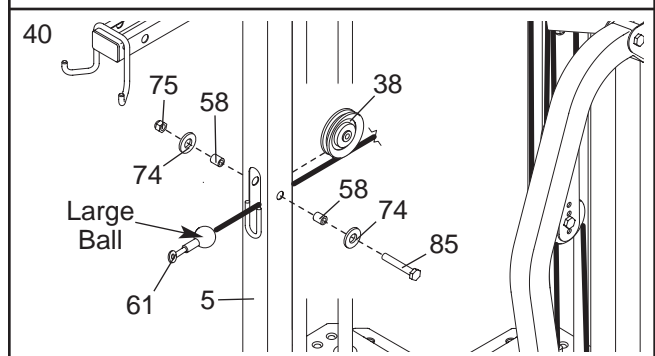

41. Wrap the High Cable (61) over a 90mm Pulley (38). Attach the Pulley to the Right Top Frame (10) with an M10 x 45mm Bolt (78) and an M10 Nylon Locknut (75).

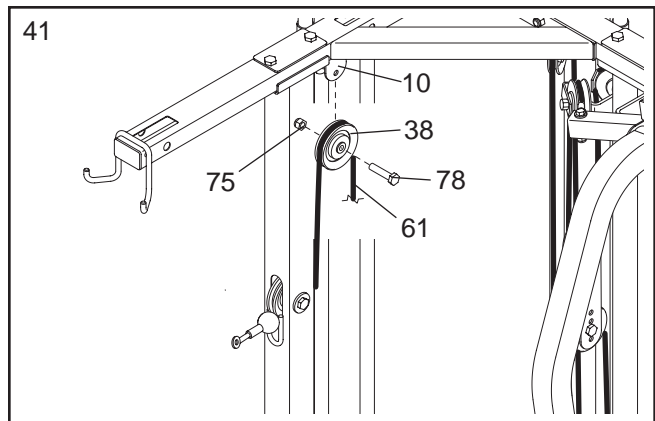

42. Wrap the High Cable (61) under a 90mm Pulley (38). Attach the Pulley and a Cable Trap (37) to the second set of holes from the top of the Double "U"-bracket (41) with an M10 x 48mm Bolt (23) and an M10 Nylon Locknut (75). **Make sure the Cable Trap is turned to hold the Cable in the groove of the Pulley.**

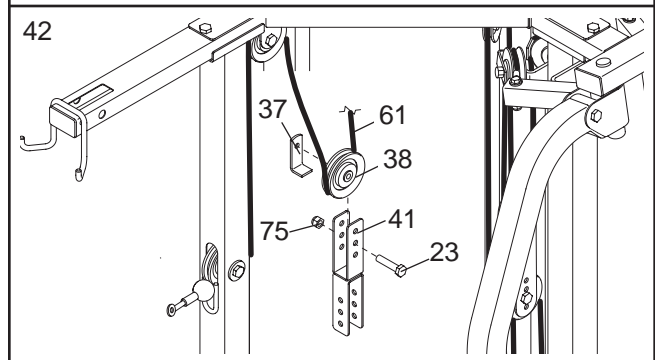

43. Route the High Cable (61) up through the Right Top Frame (10) and over a 90mm Pulley (38). Attach the Pulley inside the Top Frame with an M10 x 78mm Bolt (85), two M10 Washers (74), two 17mm Spacers (58), and an M10 Nylon Locknut (75).

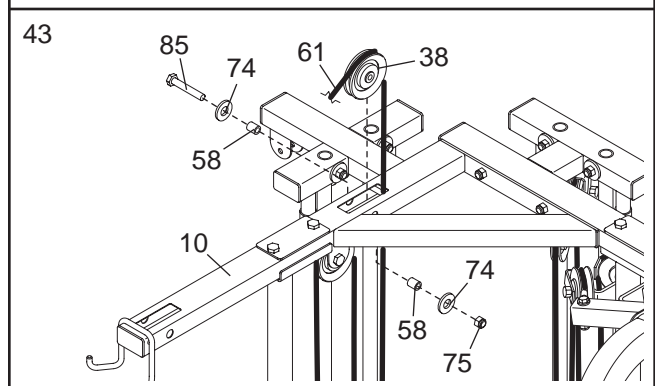

44. Route the High Cable (61) over a 90mm Pulley (38) and down through the Right Top Frame (10). Attach the Pulley inside the Top Frame with an M10 x 78mm Bolt (85), two M10 Washers (74), two 17mm Spacers (58), and an M10 Nylon Locknut (75).

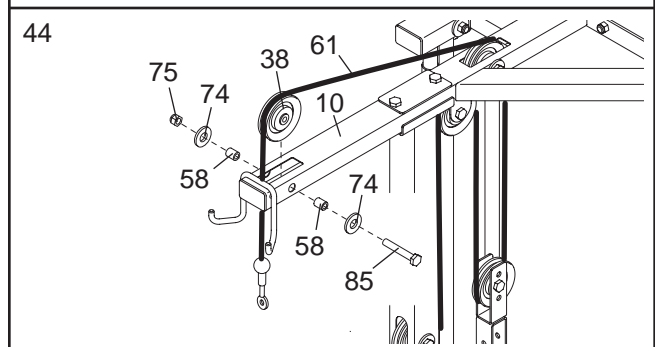

45. **Locate the Long Cable (62).** Attach the eyelet on the Cable to the Right Upright (5) with an M10 x 110mm Bolt (88), an M10 Small Washer (33), and an M10 Nylon Locknut (75). **Do not tighten the Locknut yet.**

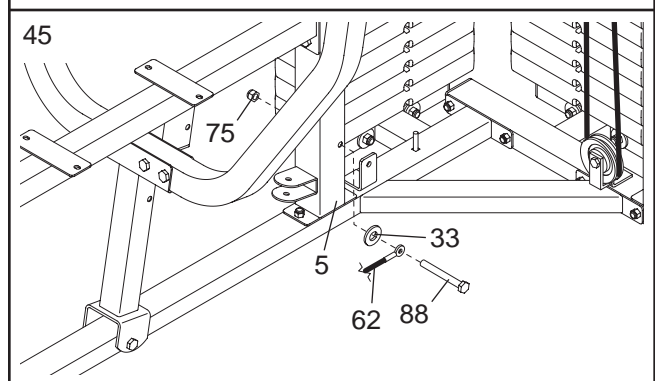

46. Wrap the Long Cable (62) under a 90mm Pulley (38). Attach the Pulley and a Cable Trap (37) to the Press Frame (14) with an M10 x 119mm Bolt (76) and an M10 Nylon Locknut (75). **Make sure that the Cable Trap is turned to hold the Cable in place. Do not tighten the Locknut yet.**

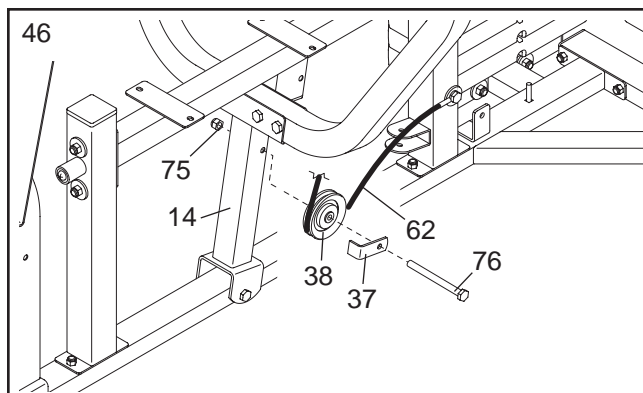

47. Wrap the Long Cable (62) under a 90mm Pulley (38). Attach the Pulley and a Cable Trap (37) to the Right Seat Frame (3) with an M10 x 119mm Bolt (76) and an M10 Nylon Locknut (75). **Make sure that the Cable Trap is turned to hold the Cable in place. Do not tighten the Locknut yet.**

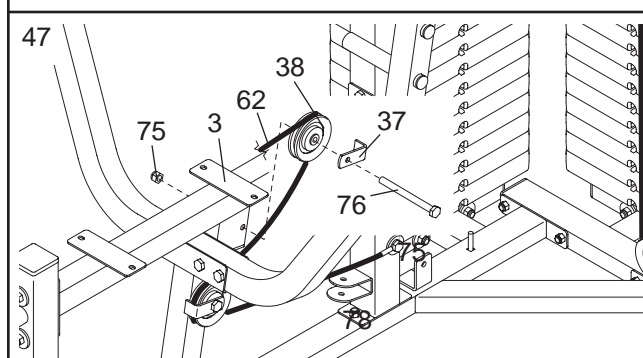

48. Wrap the Long Cable (62) over a 90mm Pulley (38). Attach the Pulley and a Cable Trap (37) to the Leg Press Arm (12) with an M10 x 123mm Bolt (98), an M10 Large Washer (94), and an M10 Nylon Locknut (75). **Make sure that the Cable Trap is turned to hold the Cable in place. Do not tighten the Locknut yet.**

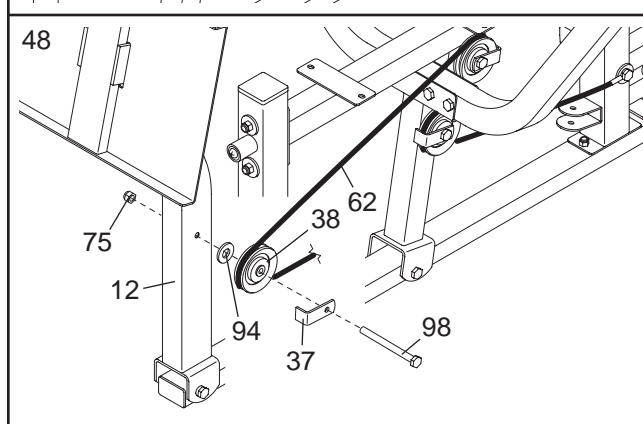

49. Wrap the Long Cable (62) around a 90mm Pulley (38). Attach the Pulley to the Right Upright (5) with an M10 x 45mm Bolt (78) and an M10 Nylon Locknut (75). **Make sure that the Cable Trap is turned to hold the Cable in place.**

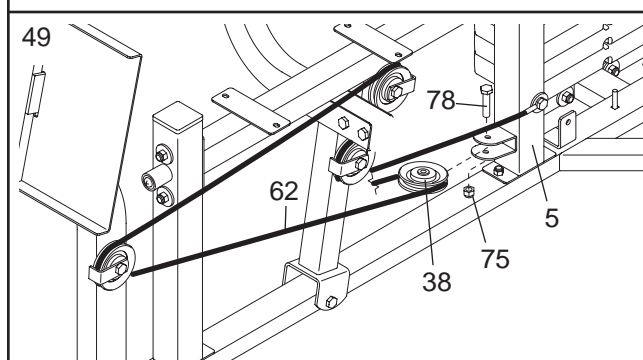

50. Remove the M10 Nylon Locknut (75) used in step 48.

Wrap the Long Cable (62) under a 90mm Pulley (38). Attach the Pulley and a Cable Trap (37) to the Leg Press Arm (12) with the M10 x 123mm Bolt (98) used in step 48, an M10 Large Washer (94), and the M10 Nylon Locknut (75). **Make sure that the Cable Trap is turned to hold the Cable in place.**

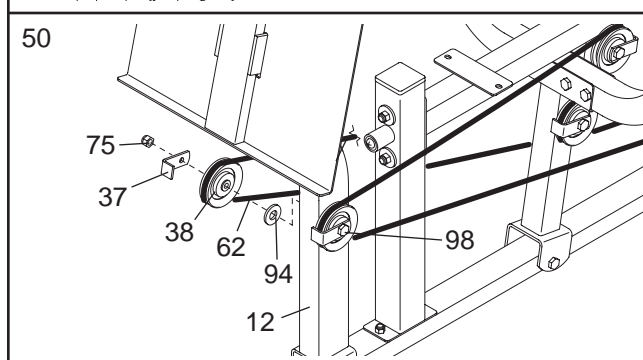

51. Remove the M10 Nylon Locknut (75) used in step 47.

Wrap the Long Cable (62) over a 90mm Pulley (38). Attach the Pulley and a Cable Trap (37) to the Right Seat Frame (3) with the M10 x 119mm Bolt (76) used in step 47 and the M10 Nylon Locknut (75). **Make sure that the Cable Trap is turned to hold the Cable in place.**

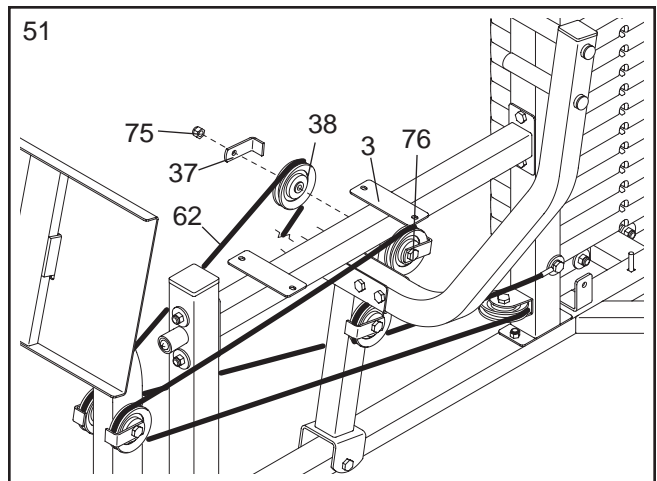

52. Remove the M10 Nylon Locknut (75) used in step 46.

Wrap the Long Cable (62) over a 90mm Pulley (38). Attach the Pulley and a Cable Trap (37) to the Press Frame (14) with the M10 x 119mm Bolt (76) used in step 46, and the M10 Nylon Locknut (75). **Make sure that the Cable Trap is turned to hold the Cable in place.**

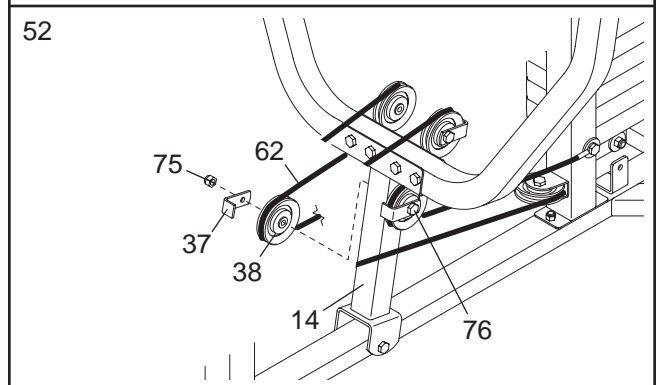

53. Remove the M10 Nylon Locknut (75) used in step 45.

Wrap the Long Cable (62) under a 90mm Pulley (38). Attach the Pulley and a Cable Trap (37) to the Right Upright (5) with the M10 x 110mm Bolt (88) used in step 45, an M10 Washer (74), and the M10 Nylon Locknut (75). **Make sure that the Cable Trap is turned to hold the Cable in place.**

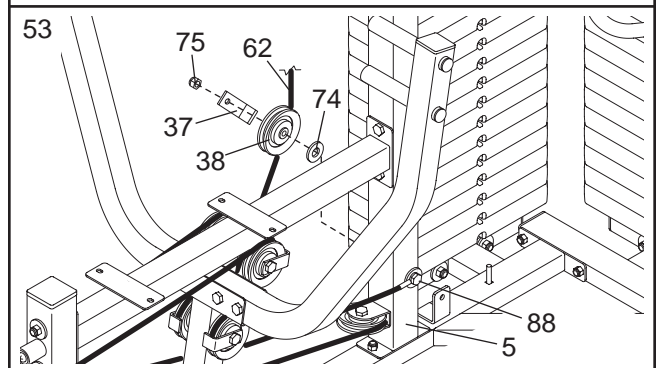

54. Wrap the Long Cable (62) over a 90mm Pulley (38). Attach the Pulley and a Cable Trap (37) to the second set of holes from the bottom of the Double "U"-bracket (41) with an M10 x 48mm Bolt (23) and an M10 Nylon Locknut (75). **Make sure the Cable Trap is turned to hold the Cable in the groove of the Pulley.**

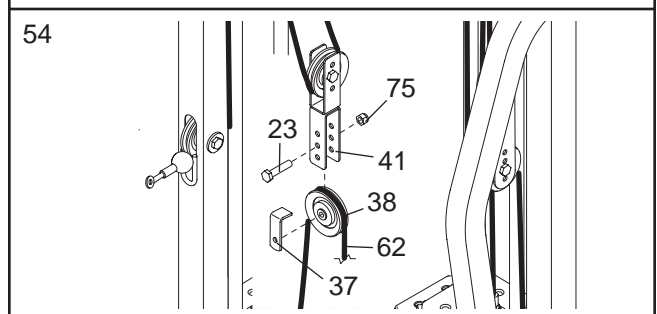

55. Wrap the Long Cable (62) under a 90mm Pulley (78). Attach the Pulley and a Cable Trap (37) to the Right Base (1) with an M10 x 48mm Bolt (23) and an M10 Nylon Locknut (75). **Make sure that the Cable Trap is turned to hold the Cable in place.**

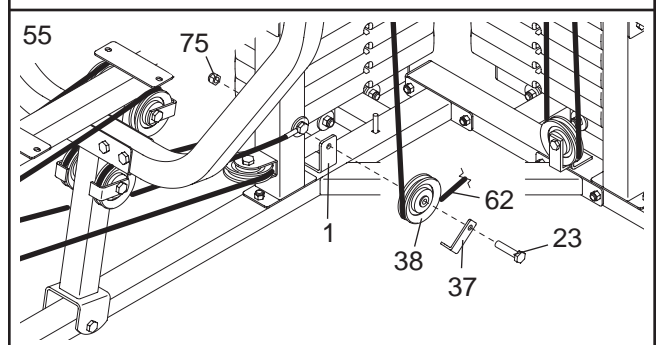

56. Wrap the Long Cable (62) around a 90mm Pulley (38). Attach the Pulley and a Cable Trap (37) to the M10 x 78mm Carriage Bolt (84) in the Right Base (1) with an M10 Nylon Locknut (75). **Make sure the Cable Trap is oriented to hold the Cable in the groove of the Pulley.**

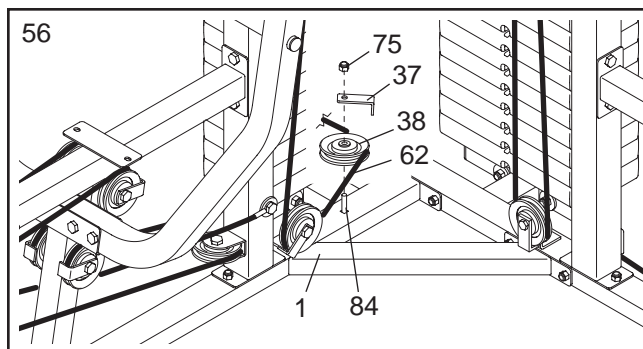

57. **Note: The next three steps are shown from the back of the weight system.**

Route the Long Cable (62) under the right stack of Weights (30) and through the bracket on the Right Base (1). Attach a 90mm Pulley (38) over the Cable with an M10 x 45mm Bolt (78) and an M10 Nylon Locknut (75).

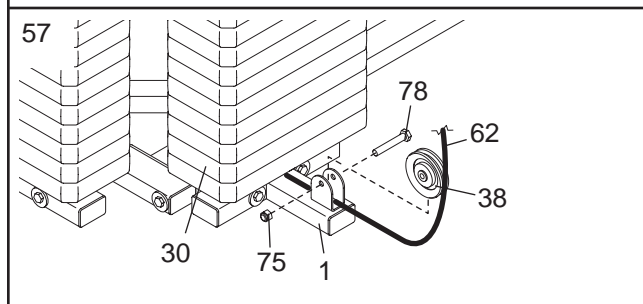

58. Route the Long Cable (62) over a 90mm Pulley (38). Attach the Pulley to the indicated bracket on the Right Top Frame (10) with an M10 x 45mm Bolt (78) and an M10 Nylon Locknut (75).

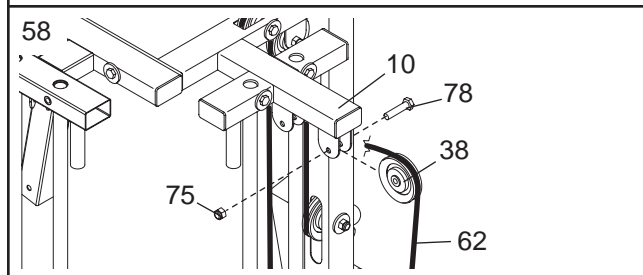

59. Route the Long Cable (62) over a 90mm Pulley (38). Attach the Pulley to the indicated bracket on the Right Top Frame (10) with an M10 x 45mm Bolt (78) and an M10 Nylon Locknut (75).

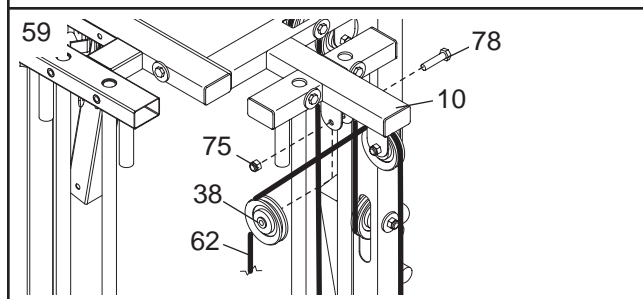

60. Thread an M12 Nut (80) onto the Long Cable (62) as far as it will go. Slide a 50mm Washer (59) onto the Cable and thread the Cable into the right Weight Tube (34) until the Cable is tight. Tighten the Nut against the Washer.

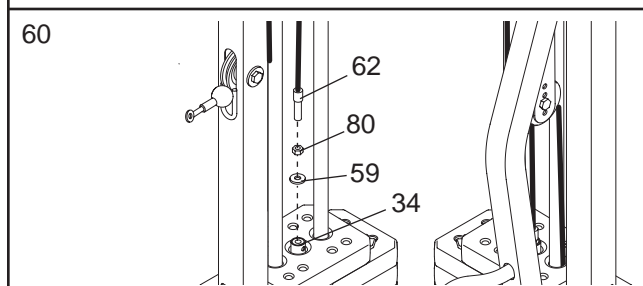

Seat Assembly

61. **Locate and open the parts bag labeled "SEAT ASSEMBLY."**

Attach the Seat (26) with the serial number decal to the Left Seat Frame (4) with four M6 x 16mm Screws (79). **Attach the other Seat to the Right Seat Frame (not shown) in the same manner.**

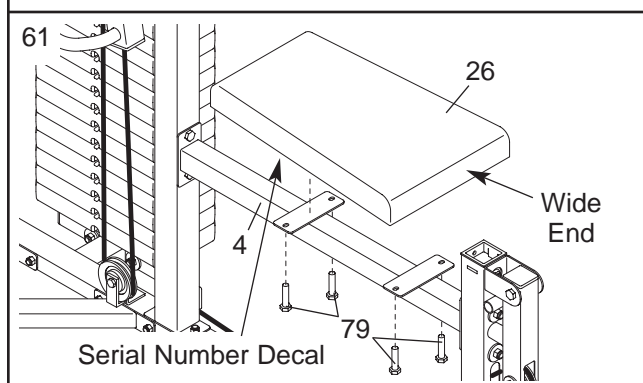

62. Press a 38mm Square Inner Cap (44) into a Backrest Frame (16). Attach a Backrest (27) to the Backrest Frame with four M6 x 20mm Screws (96).

Pull the Backrest Knob (48) on the Left Upright (6) out as far as it will go and insert the Backrest Frame (16) into the Upright. Engage the Knob into one of the holes in the Backrest Frame, and turn the Knob clockwise until it is tight.

Attach the other Backrest to the Right Upright (not shown) in the same manner. Note: The tops of the Backrests should be closer to the Uprights than the bottoms.

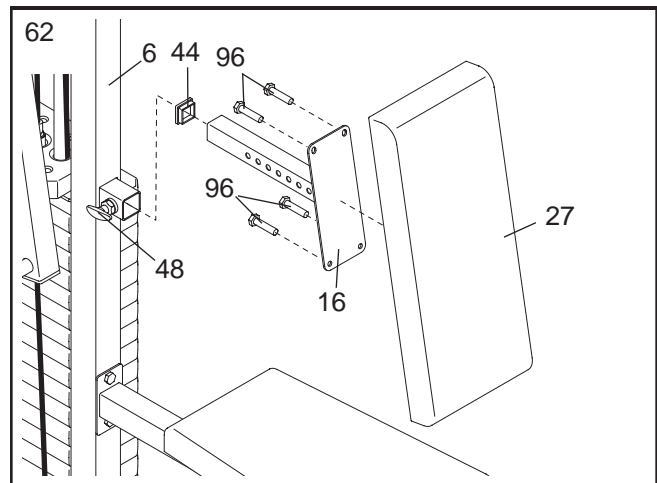

63. Press the two 19mm Round Inner Caps (24) into the ends of a Pad Tube (17). Insert the Pad Tube into the tube on the Left Leg (8). Slide the two Foam Pads (25) onto the Pad Tube as shown.

Assemble the other Pad Tube (17) to the Leg Lever (18) in the same manner.

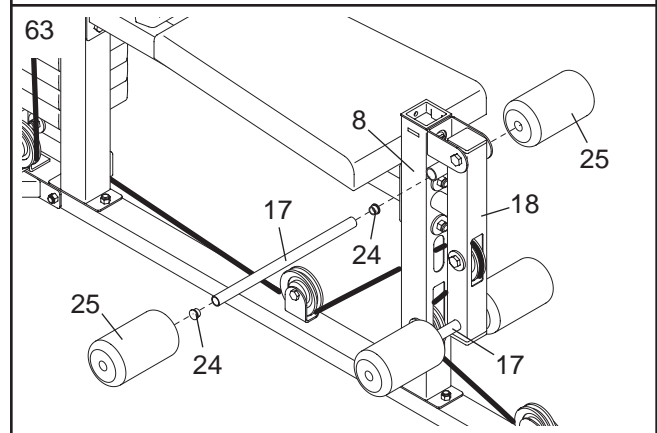

64. Attach the Curl Pad (28) to the Curl Post (19) with four M6 x 16mm Screws (79).

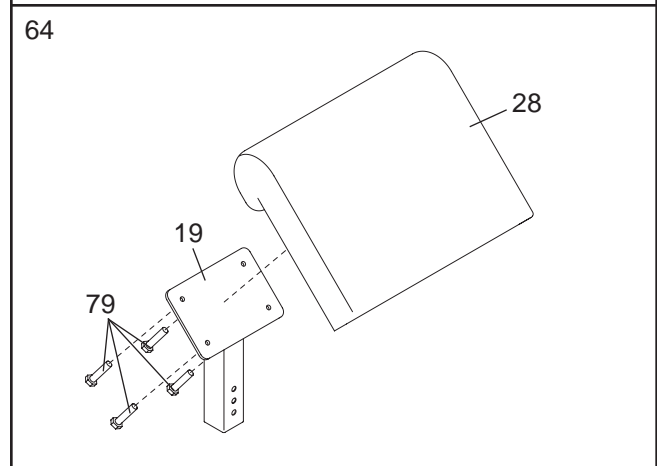

65. Make sure that all parts have been properly tightened. The use of the remaining parts will be explained in ADJUSTMENTS, beginning on the following page.

Before using the weight system, pull each cable a few times to make sure that the cables move smoothly over the pulleys. If one of the cables does not move smoothly, find and correct the problem. **IMPORTANT: If the cables are not properly installed, they may be damaged when heavy weight is used. See the CABLE DIAGRAMS on pages 27 and 28 of this manual for proper cable routing. If there is any slack in the cables, you will need to remove the slack by tightening the cables. See TROUBLESHOOTING on page 26.**

ADJUSTMENTS

This section explains how to adjust the weight system. See the EXERCISE GUIDELINES on page 29 for important information about how to get the most benefit from your exercise program. Also, refer to the accompanying exercise guide to see the correct form for each exercise. **IMPORTANT: When attaching the accessories, make sure that they are in the correct starting position for the exercise to be performed. If there is any slack in the cables or chain as an exercise is performed, the effectiveness of the exercise will be reduced.**

Make sure all parts are properly tightened each time the weight system is used. Replace any worn parts immediately. The weight system can be cleaned with a damp cloth and a mild, non-abrasive detergent. Do not use solvents.

ADJUSTING THE BACKRESTS

To adjust the position of a Backrest (27), first turn the Backrest Knob (48) counterclockwise several turns to loosen it. Next, pull the Knob and slide the Backrest Frame (16) to the desired position. Engage the Knob into one of the holes in the Backrest Frame, and turn the Knob clockwise until it is tight.

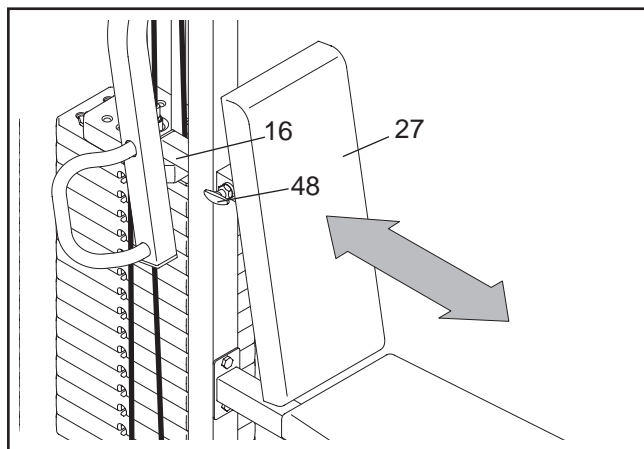

ADJUSTING THE CURL PAD

To use the Curl Pad (28), insert the Curl Post (19) into the Left Leg (8). Tighten the Curl Knob (56) into the Left Leg and the Curl Post.

When the Curl Pad (28) is not in use, remove the Curl Knob (56) and the Curl Post (19) from the Left Leg (8). **Store the Curl Pad out of the way of the weight system.**

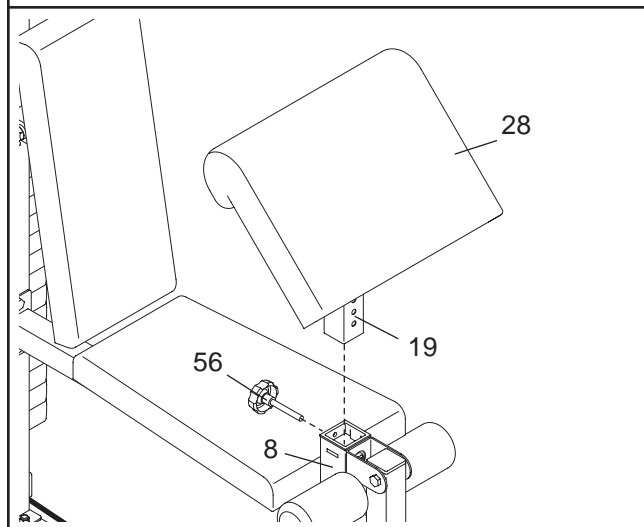

ATTACHING THE ACCESSORIES

Attach the Lat Bar (69) to the High Cable (61) at the high pulley station with a Cable Clip (71). For some exercises, the Chain (70) should be attached between the Lat Bar and the Cable with two Cable Clips.

Adjust the length of the Chain between the Lat Bar and the Cable so the Lat Bar is in the correct starting position for the exercise to be performed.

The Ankle Strap (not shown) or the Ab Strap (not shown) can be attached to a cable at any of the pulley stations in the same manner.

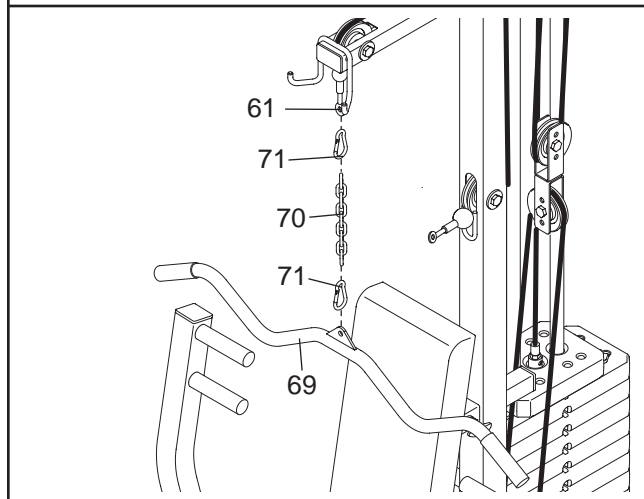

CHANGING THE WEIGHT SETTING

To change the setting of a weight stack, insert a Weight Pin (32) under the desired Weight (30). Insert the Weight Pin so that the bent end touches the weight stack. Turn the bent end down.

Note: Due to the cables and pulleys, the amount of resistance at each exercise station may vary from the weight setting. Use the WEIGHT RESISTANCE CHART on page 25 to find the approximate amount of resistance at each weight station.

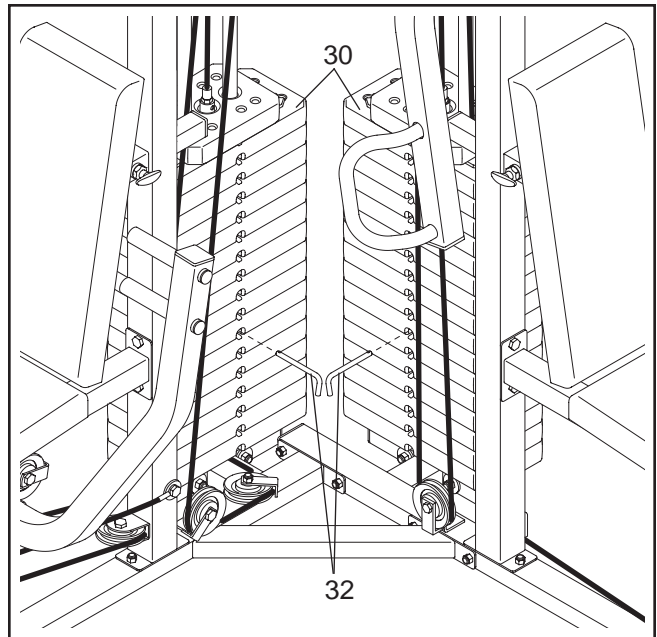

WEIGHT RESISTANCE CHART

The chart below shows the approximate weight resistance at each exercise station. "Top" refers to the 6 lb. top weight. The other numbers refer to the 12.5 lb. weight plates. Weight resistance shown for the butterfly arm station is for each butterfly arm. **Note: The actual resistance at each station may vary due to differences in individual weight plates as well as friction between the cables, pulleys, and weight guides.**

WEIGHT	HIGH PULLEY (lbs.)	AB PULLEY (lbs.)	PRESS ARM (lbs.)	LEG PRESS (lbs.)	BUTTER-FLY ARM (lbs.)	LEG LEVER (lbs.)	LOW PULLEY (lbs.)
Top	20	21	32	47	9	25	22
1	35	35	50	70	14	39	36
2	51	51	71	101	20	54	51
3	68	66	90	128	25	70	67
4	84	81	110	157	31	86	82
5	100	96	130	186	38	102	97
6	116	111	150	215	45	118	112
7	132	126	170	244	52	134	127
8	148	141	190	273	59	150	142
9	164	156	210	302	66	166	157
10	180	171	230	331	73	182	172
11	196	186	250	360	80	198	187
12	212	201	270	387	87	214	202
13	228	216	290	415	94	230	217
14	244	231	310	445	101	246	232
15	260	246	330	475	106	262	247
16	273	265	348	501	110	274	260

TROUBLESHOOTING

Make sure all parts are properly tightened each time the weight system is used. Replace any worn parts immediately. The weight system can be cleaned using a damp cloth and mild non-abrasive detergent. Do not use solvents.

TIGHTENING THE CABLES

Woven cable, the type of cable used on the weight system, can stretch slightly when it is first used. If there is slack in the cables before resistance is felt, the cables should be tightened. To tighten the cables, first insert the weight pins into the centers of the weight stacks. Slack can be removed from the cables in several ways:

See drawing 1. Remove an M10 Nylon Locknut (75), M10 x 48mm Bolt (23), 90mm Pulley (38), and Cable Trap (37) from the Double "U"-bracket (41). Reattach the Pulley and the Cable Trap between a set of holes closer to the center of the "U"-bracket with the Bolt and Locknut. **Make sure the Cable Trap is turned to hold the Cable in the groove of the Pulley.**

Adjust the 90mm Pulleys (38) attached to the two Pulley Plates (36 [not shown]) in the same manner.

See drawing 2. To tighten the Long Cable (62) or the Low Cable (63), loosen the M12 Nut (80) away from the 50mm Washer (59). Screw the Cable into the Weight Tube (34) and retighten the Nut against the Washer.

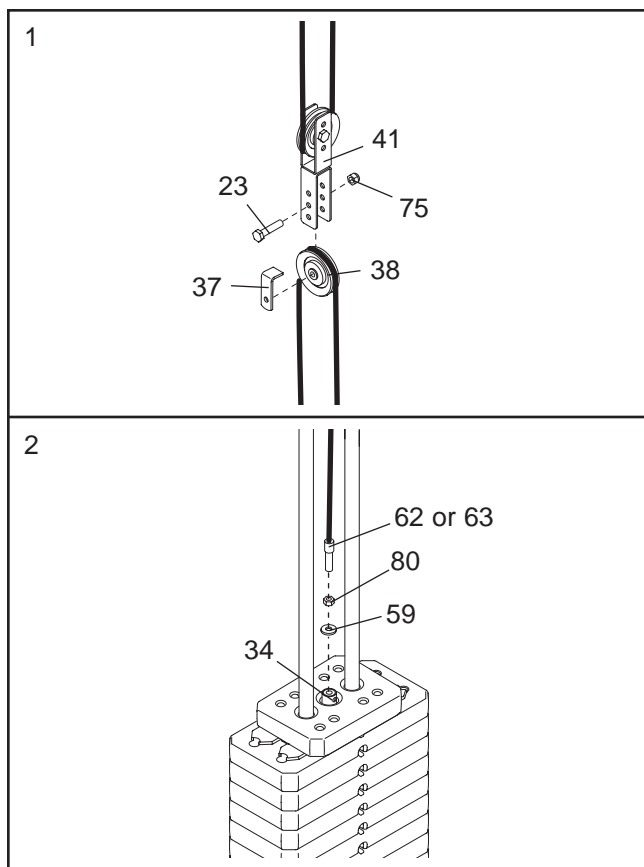

Do not overtighten the cables. If the cables are overtightened, the top weights will be lifted off the weight stacks.

If a cable slips off the pulleys repeatedly, it may have become twisted. Remove the cable and re-install it. If the cables need to be replaced, see ORDERING REPLACEMENT PARTS on the back cover of this manual.

CABLE DIAGRAMS

The cable diagrams show the proper routing of the High Cable (61), the Long Cable (62), the Low Cable (63), and the Butterfly Cable (64). Use the diagrams to make sure that the cables and the cable traps have been assembled correctly. If the cables have not been correctly routed, the weight system will not function properly and damage may occur. The numbers show the correct route for each cable. **Make sure that the cable traps do not touch or bind the cables.**

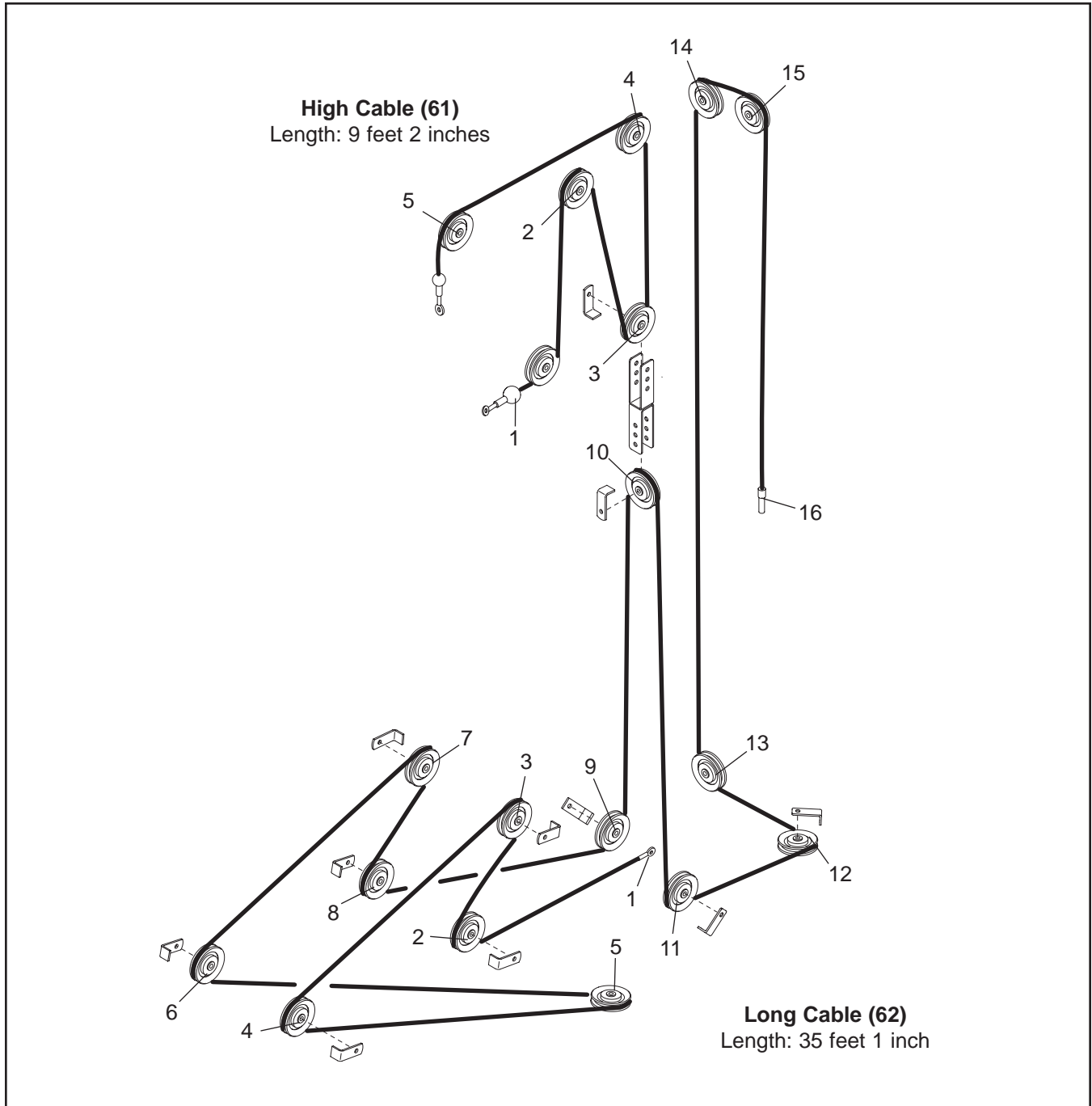

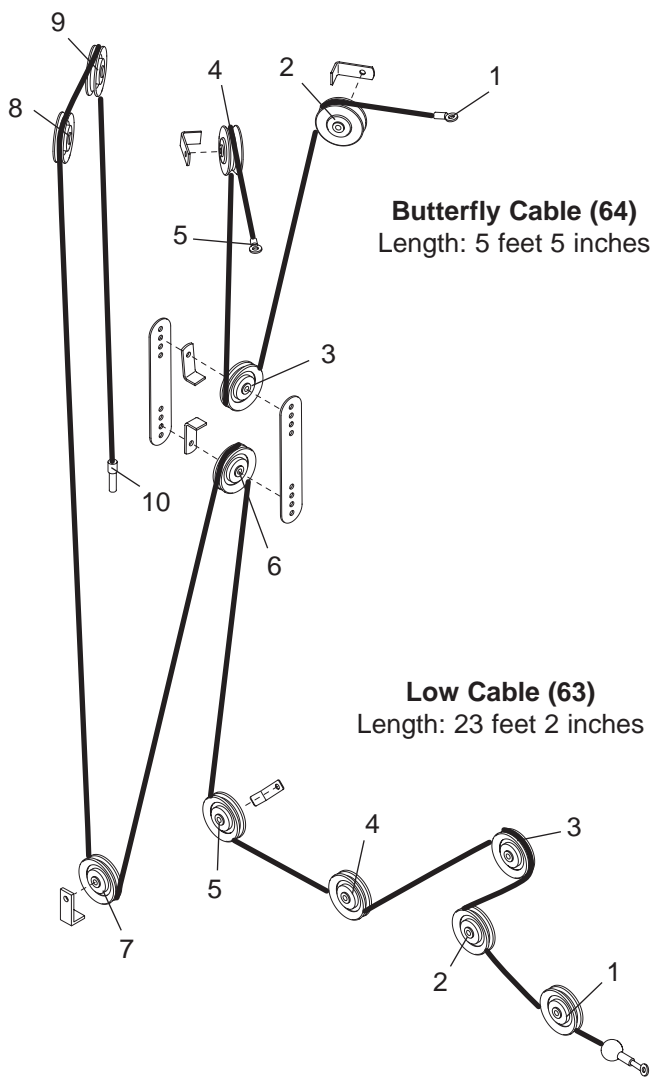

EXERCISE GUIDELINES

THE FOUR BASIC TYPES OF WORKOUTS

MUSCLE BUILDING

To increase the size and strength of your muscles, push them close to their maximum capacity. Your muscles will continually adapt and grow as you progressively increase the intensity of your exercise. You can adjust the intensity level of an individual exercise in two ways:

- by changing the amount of resistance used
- by changing the number of repetitions or sets performed. (A “repetition” is one complete cycle of an exercise, such as one sit-up. A “set” is a series of repetitions.)

The proper amount of resistance for each exercise depends upon the individual user. You must gauge your limits and select the amount of resistance that is right for you. Begin with 3 sets of 8 repetitions for each exercise you perform. Rest for 3 minutes after each set. When you can complete 3 sets of 12 repetitions without difficulty, increase the amount of resistance.

TONING

You can tone your muscles by pushing them to a moderate percentage of their capacity. Select a moderate amount of resistance and increase the number of repetitions in each set. Complete as many sets of 15 to 20 repetitions as possible without discomfort. Rest for 1 minute after each set. Work your muscles by completing more sets rather than by using high amounts of resistance.

WEIGHT LOSS

To lose weight, use a low amount of resistance and increase the number of repetitions in each set. Exercise for 20 to 30 minutes, resting for a maximum of 30 seconds between sets.

CROSS TRAINING

Cross training is an efficient way to get a complete and well-balanced fitness program. An example of a balanced program is:

- Plan strength training workouts on Monday, Wednesday, and Friday.
- Plan 20 to 30 minutes of aerobic exercise, such as running on a treadmill or riding on an elliptical or exercise bike, on Tuesday and Thursday.
- Rest from both strength training and aerobic exercise for at least one full day each week to give your body time to regenerate.

The combination of strength training and aerobic exercise will reshape and strengthen your body, plus develop your heart and lungs.

PERSONALIZING YOUR EXERCISE PROGRAM

Determining the exact length of time for each workout, as well as the number of repetitions or sets completed, is an individual matter. It is important to avoid overdoing it during the first few months of your exercise program. You should progress at your own pace and be sensitive to your body’s signals. If you experience pain or dizziness at any time while exercising, stop immediately and begin cooling down. Find out what is wrong before continuing. Remember that adequate rest and a proper diet are important factors in any exercise program.

WARMING UP

Begin each workout with 5 to 10 minutes of stretching and light exercise to warm up. Warming up prepares your body for more strenuous exercise by increasing circulation, raising your body temperature and delivering more oxygen to your muscles.

WORKING OUT

Each workout should include 6 to 10 different exercises. Select exercises for every major muscle group, emphasizing areas that you want to develop most. To give balance and variety to your workouts, vary the exercises from session to session.

Schedule your workouts for the time of day when your energy level is the highest. Each workout should be followed by at least one day of rest. Once you find the schedule that is right for you, stick with it.

EXERCISE FORM

Maintaining proper form is an essential part of an effective exercise program. This requires moving through the full range of motion for each exercise, and moving only the appropriate parts of the body. Exercising in an uncontrolled manner will leave you feeling exhausted. On the exercise guide accompanying this manual you will find photographs showing the correct form for several exercises, and a list of the muscles affected. Refer to the muscle chart on the next page to find the names of the muscles.

The repetitions in each set should be performed smoothly and without pausing. The exertion stage of each repetition should last about half as long as the return stage. Proper breathing is important. Exhale during the exertion stage of each repetition and inhale during the return stroke. Never hold your breath.

Rest for a short period of time after each set. The ideal resting periods are:

- Rest for three minutes after each set for a muscle building workout.
- Rest for one minute after each set for a toning workout.
- Rest for 30 seconds after each set for a weight loss workout.

Plan to spend the first couple of weeks familiarizing yourself with the equipment and learning the proper form for each exercise.

COOLING DOWN

End each workout with 5 to 10 minutes of stretching. Include stretches for both your arms and legs. Move

slowly as you stretch and do not bounce. Ease into each stretch gradually and go only as far as you can without strain. Stretching at the end of each workout is an effective way to increase flexibility.

STAYING MOTIVATED

For motivation, keep a record of each workout. The chart on page 31 of this manual can be photocopied and used to schedule and record your workouts. List the date, the exercises performed, the resistance used, and the numbers of sets and repetitions completed. Record your weight and key body measurements at the end of every month. Remember, the key to achieving the greatest results is to make exercise a regular and enjoyable part of your everyday life.

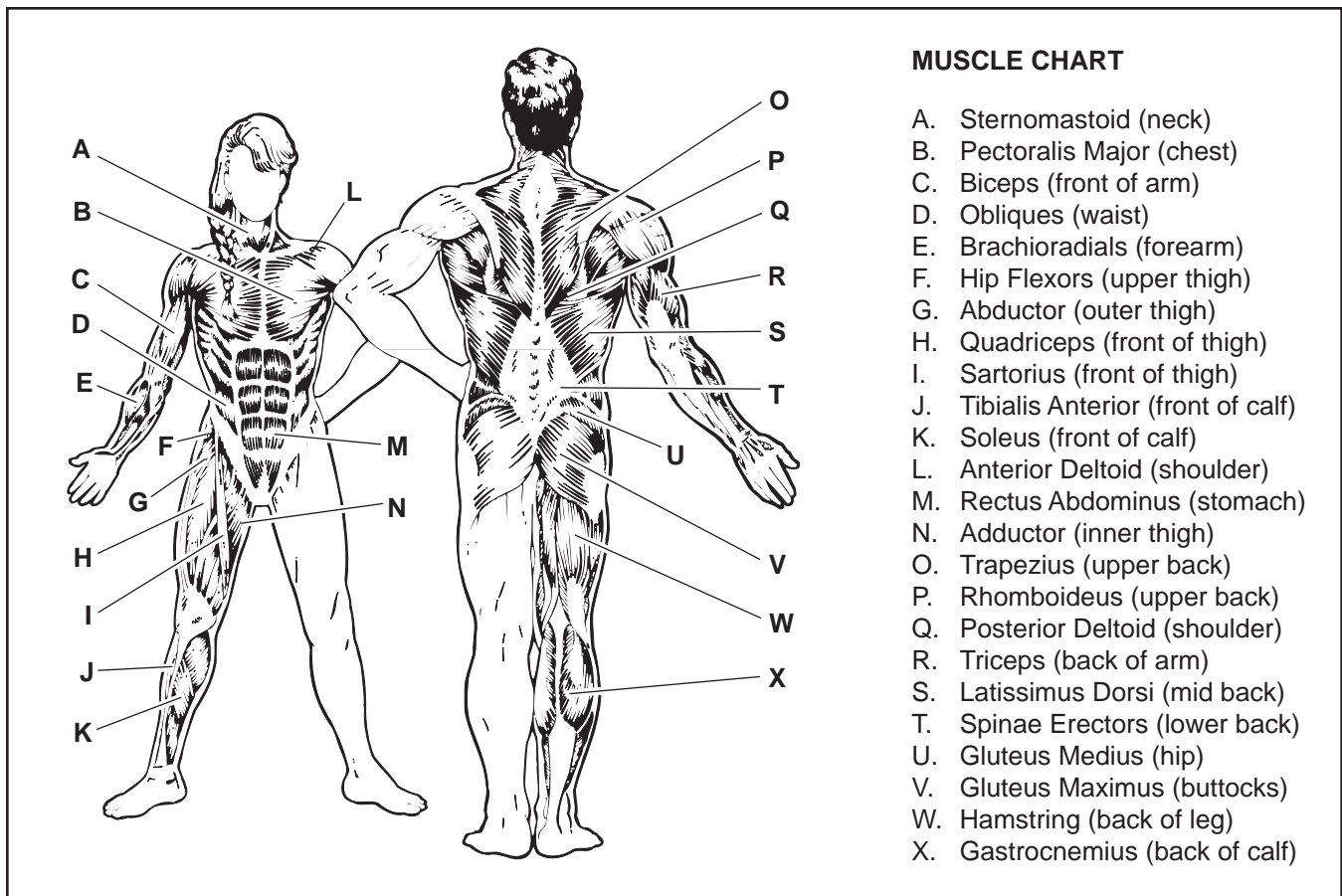

MONDAY	EXERCISE	WEIGHT	SETS	REPS
Date: _____ / _____ / _____				

TUESDAY AEROBIC EXERCISE

Date: _____ / _____ / _____

WEDNESDAY	EXERCISE	WEIGHT	SETS	REPS
Date: _____ / _____ / _____				

THURSDAY AEROBIC EXERCISE

Date: _____ / _____ / _____

FRIDAY	EXERCISE	WEIGHT	SETS	REPS
Date: _____ / _____ / _____				

Make photocopies of this page for scheduling and recording your workouts.

PART IDENTIFICATION CHART—Model No. GGSY69530

R0903A

Refer to the drawings below to identify small parts used in assembly. The number in parentheses by each drawing is the key number of the part, from the PART LIST in the center of this manual. **Note: Some small parts may have been pre-attached. If a part is not in the parts bag, check to see if it has been pre-attached.**

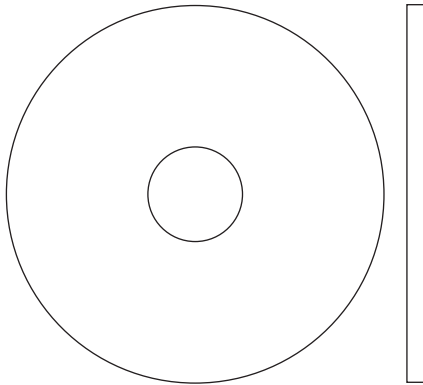

50mm Washer (59)

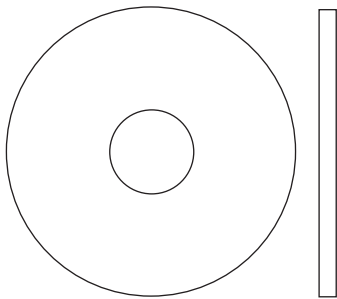

M10 Large Washer (94)

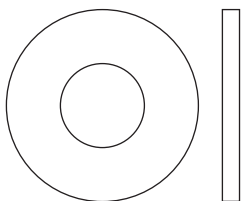

M10 Washer (74)

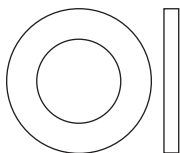

M10 Small Washer (33)

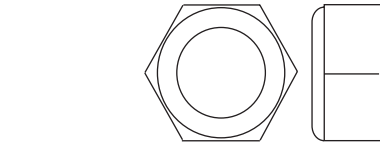

M12 Nut (95)

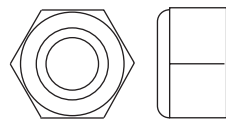

M10 Nylon Locknut (75)

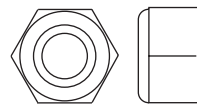

M8 Nylon Locknut (54)



M4 Washer (93)

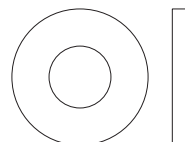

M8 Washer (90)

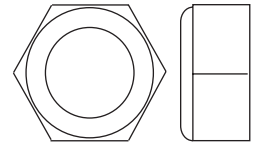

M12 Locknut (95)



M6 x 16mm Screw (79)

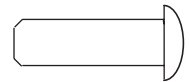

M6 x 20mm Screw (96)

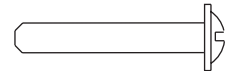

M4 x 25mm Self-tapping Screw (77)

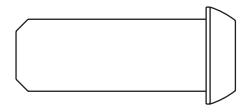

M10 x 25mm Button Screw (60)

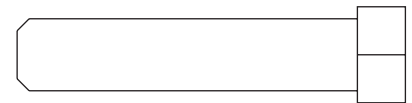

M10 x 45mm Bolt (78)

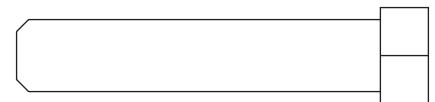

M10 x 48mm Bolt (23)

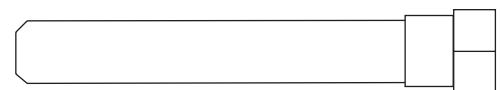

M8 x 58mm Shoulder Bolt (89)

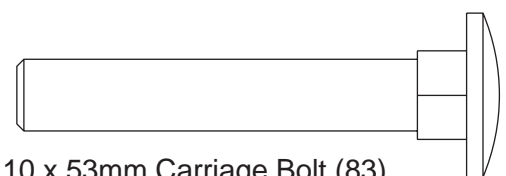

M10 x 53mm Carriage Bolt (83)

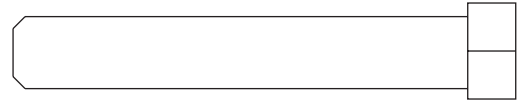

M10 x 60mm Bolt (82)

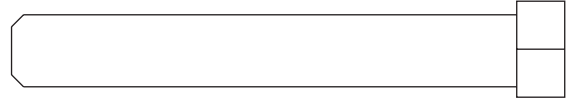

M10 x 67mm Bolt (92)



M10 x 70mm Bolt (87)



M10 x 78mm Bolt (85)

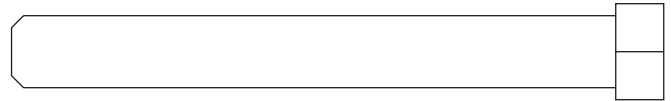

M10 x 80mm Bolt (86)

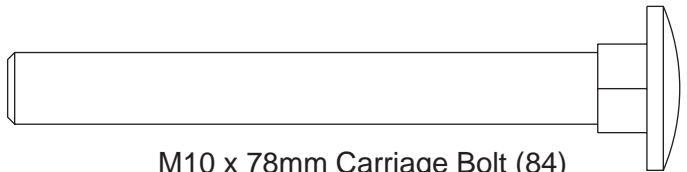

M10 x 78mm Carriage Bolt (84)

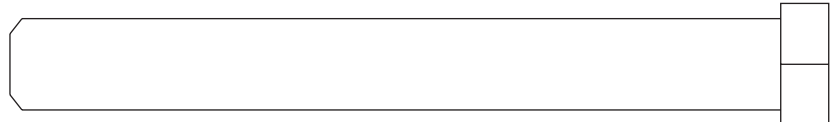

M12 x 102mm Bolt (81)

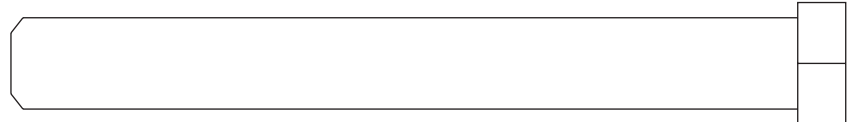

M12 x 104mm Bolt (67)



M10 x 110mm Bolt (88)

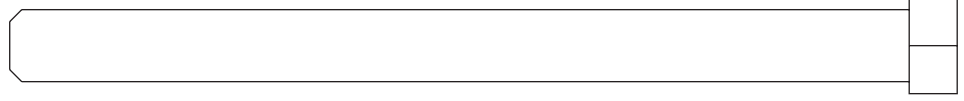

M10 x 119mm Bolt (76)

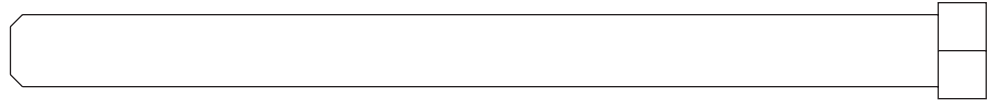

M10 x 123mm Bolt (98)

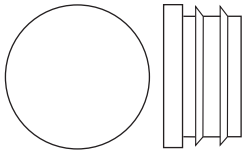

19mm Round Inner Cap (24)

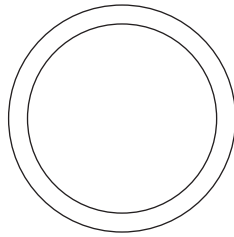

25mm Round Outer Cap (47)

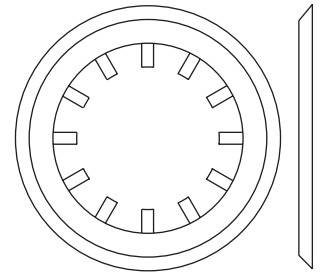

25mm Retainer Ring (53)

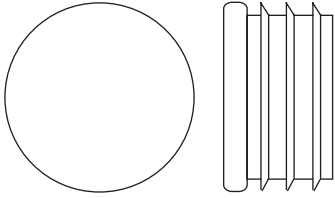

25mm Round Inner Cap (65)

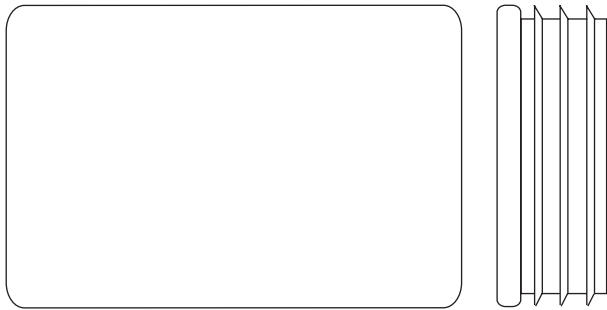

40mm x 60mm Inner Cap (42)

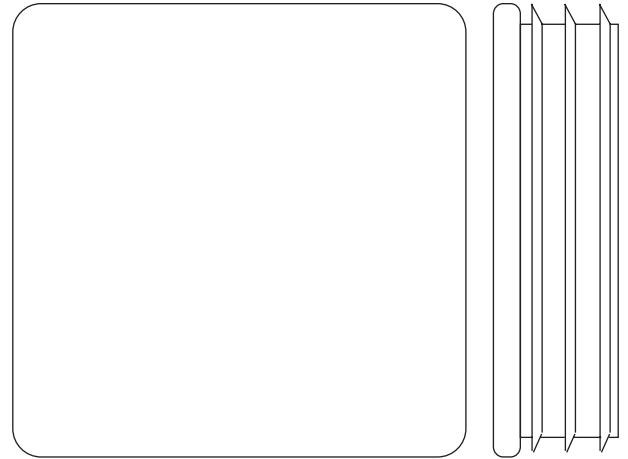

60mm Square Inner Cap (46)



40mm x 60mm Thick Inner Cap (91)

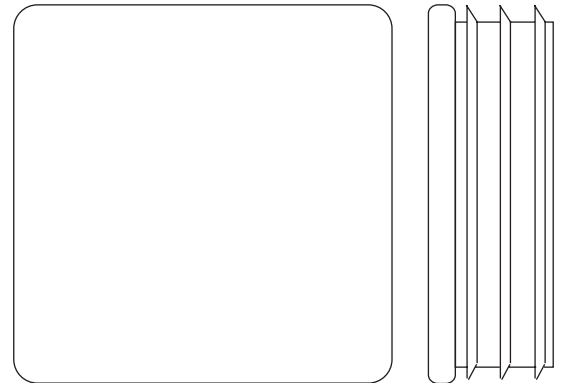

50mm Square Inner Cap (43)

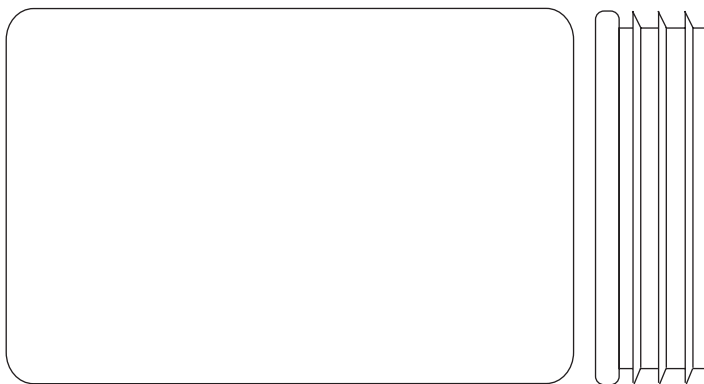

50mm x 75mm Inner Cap (45)

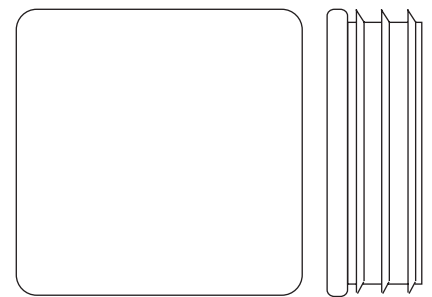

38mm Square Inner Cap (44)

PART LIST—Model No. GGSY69530

R0903A

Key No.	Qty.	Description	Key No.	Qty.	Description
1	1	Right Base	52	4	Pivot Bushing
2	1	Left Base	53	4	25mm Retainer Ring
3	1	Right Seat Frame	54	2	M8 Nylon Locknut
4	1	Left Seat Frame	55	1	Square Bushing
5	1	Right Upright	56	1	Curl Knob
6	1	Left Upright	57	2	12mm Spacer
7	1	Right Leg	58	24	17mm Spacer
8	1	Left Leg	59	2	50mm Washer
9	4	Weight Guide	60	4	M10 x 25mm Button Screw
10	1	Right Top Frame	61	1	High Cable
11	1	Left Top Frame	62	1	Long Cable
12	1	Leg Press Arm	63	1	Low Cable
13	1	Leg Press Plate	64	1	Butterfly Cable
14	1	Press Frame	65	4	25mm Round Inner Cap
15	2	Press Arm	66	2	Fly Handle
16	2	Backrest Frame	67	1	M12 x 104mm Bolt
17	2	Pad Tube	68	6	Grip
18	1	Leg Lever	69	1	Lat Bar
19	1	Curl Post	70	1	Chain
20	2	Butterfly Arm	71	3	Cable Clip
21	1	Left Fly Pivot	72	1	Ab Strap
22	1	Right Fly Pivot	73	1	Ankle Strap
23	7	M10 x 48mm Bolt	74	37	M10 Washer
24	4	19mm Round Inner Cap	75	69	M10 Nylon Locknut
25	4	Foam Pad	76	2	M10 x 119mm Bolt
26	2	Seat	77	2	M4 x 25mm Self-taping Screw
27	2	Backrest	78	9	M10 x 45mm Bolt
28	1	Curl Pad	79	12	M6 x 16mm Screw
29	2	Support Plate	80	2	M12 Nut
30	32	Weight	81	2	M12 x 102mm Bolt
31	2	Top Weight	82	6	M10 x 60mm Bolt
32	2	Weight Pin	83	8	M10 x 53mm Carriage Bolt
33	1	M10 Small Washer	84	1	M10 x 78mm Carriage Bolt
34	2	Weight Tube	85	17	M10 x 78mm Bolt
35	2	Weight Tube Bumper	86	12	M10 x 80mm Bolt
36	2	Pulley Plate	87	4	M10 x 70mm Bolt
37	15	Cable Trap	88	1	M10 x 110mm Bolt
38	29	90mm Pulley	89	2	M8 x 58mm Shoulder Bolt
39	2	Large Cable Trap	90	4	M8 Washer
40	2	"V"-pulley	91	2	40mm x 60mm Thick Inner Cap
41	1	Double "U"-bracket	92	1	M10 x 67mm Bolt
42	16	40mm x 60mm Inner Cap	93	2	M4 Washer
43	6	50mm Square Inner Cap	94	10	M10 Large Washer
44	4	38mm Square Inner Cap	95	3	M12 Locknut
45	2	50mm x 75mm Inner Cap	96	8	M6 x 20mm Screw
46	1	60mm Square Inner Cap	97	2	Long Foam Pad
47	6	25mm Round Outer Cap	98	1	M10 x 123mm Bolt
48	2	Backrest Knob	#	1	User's Manual
49	2	Leg Bumper	#	1	Exercise Guide
50	4	Weight Bumper	#	1	"L"-wrench
51	4	Round Arm Bushing	#	2	Grease Pack

Note: "#" indicates a non-illustrated part. Specifications are subject to change without notice.

EXPLODED DRAWING—Model No. GGSY69530

R0903A

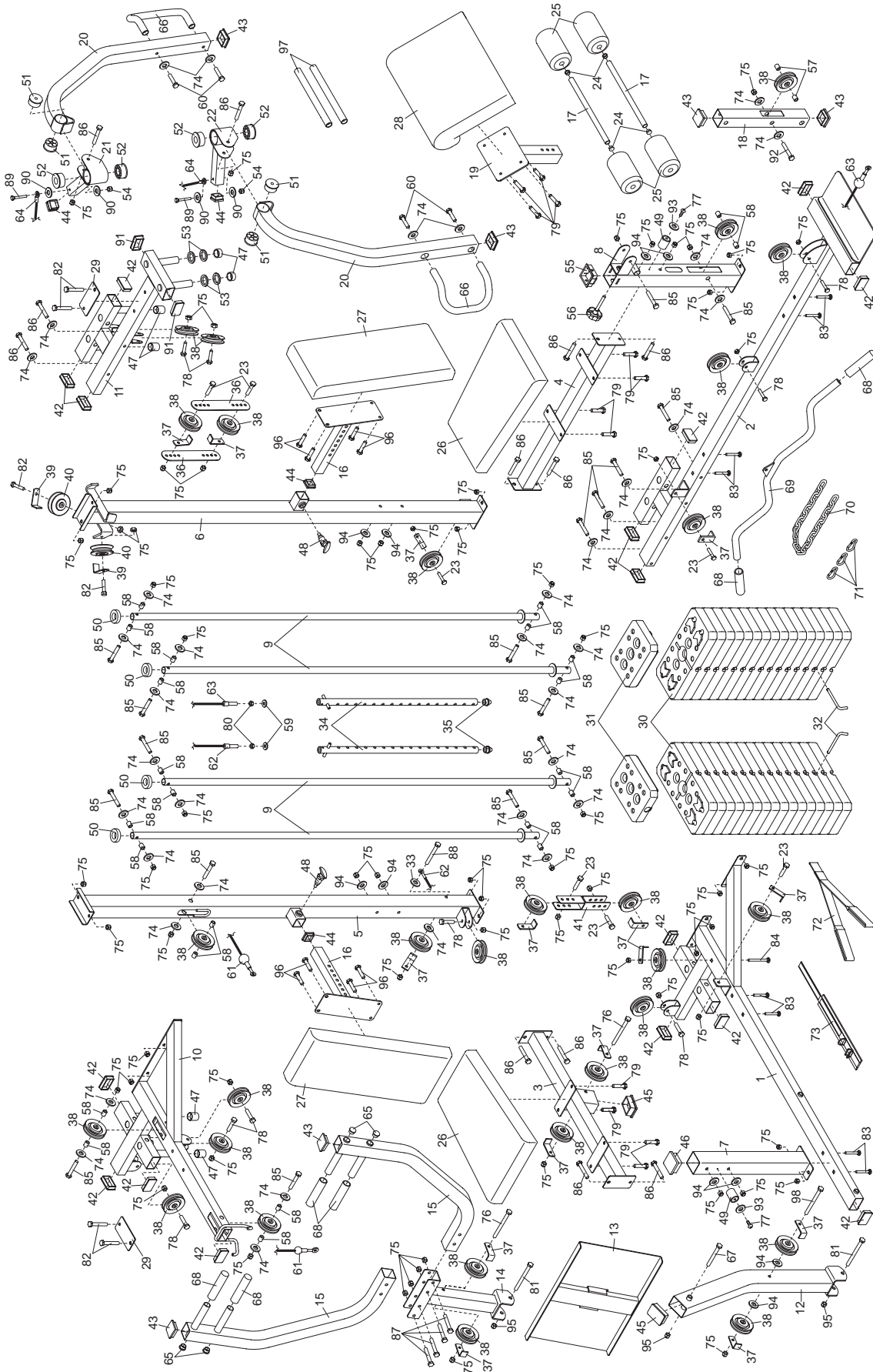

ORDERING REPLACEMENT PARTS

To order replacement parts, simply call our Customer Service Department toll-free at 1-800-999-3756, Monday through Friday, 6 a.m. until 6 p.m. Mountain Time (excluding holidays). To help us assist you, please be prepared to give the following information:

1. The MODEL NUMBER of the product (GGSY69530)
2. The NAME of the product (GOLD'S GYM® XR66 weight system)
3. The SERIAL NUMBER of the product (see the front cover of this manual)
4. The KEY NUMBER and DESCRIPTION of the part(s) (see the PART LIST and EXPLODED DRAWING in the center of this manual)

LIMITED WARRANTY

ICON Health & Fitness, Inc. (ICON), warrants this product to be free from defects in workmanship and material, under normal use and service conditions, for a period of ninety (90) days from the date of purchase. This warranty extends only to the original purchaser. ICON's obligation under this warranty is limited to replacing or repairing, at ICON's option, the product through one of its authorized service centers. All repairs for which warranty claims are made must be pre-authorized by ICON. This warranty does not extend to any product or damage to a product caused by or attributable to freight damage, abuse, misuse, improper or abnormal usage or repairs not provided by an ICON authorized service center; products used for commercial or rental purposes; or products used as store display models. No other warranty beyond that specifically set forth above is authorized by ICON.

ICON is not responsible or liable for indirect, special or consequential damages arising out of or in connection with the use or performance of the product or damages with respect to any economic loss, loss of property, loss of revenues or profits, loss of enjoyment or use, costs of removal or installation or other consequential damages of whatsoever nature. Some states do not allow the exclusion or limitation of incidental or consequential damages. Accordingly, the above limitation may not apply to you.

The warranty extended hereunder is in lieu of any and all other warranties and any implied warranties of merchantability or fitness for a particular purpose is limited in its scope and duration to the terms set forth herein. Some states do not allow limitations on how long an implied warranty lasts. Accordingly, the above limitation may not apply to you.

This warranty gives you specific legal rights. You may also have other rights which vary from state to state.

ICON HEALTH & FITNESS, INC., 1500 S. 1000 W., LOGAN, UT 84321-9813