

3:1 Mini Fire-Ball[®] 225 Oil Pump

309868D

ENG

For non-corrosive and non-abrasive oils and lubricants only. For professional use only.
Not for use in explosive atmospheres.



Important Safety Instructions

Read all warnings and instructions in this manual. Save these instructions.

Model No. 246775, Series B, Universal
Model No. 248097, Series B, Variable Length

540 psi (3.7 MPa, 37 bar) Maximum Working Pressure

180 psi (1.24 MPa, 12.4 bar) Maximum Air Input Pressure

Contents



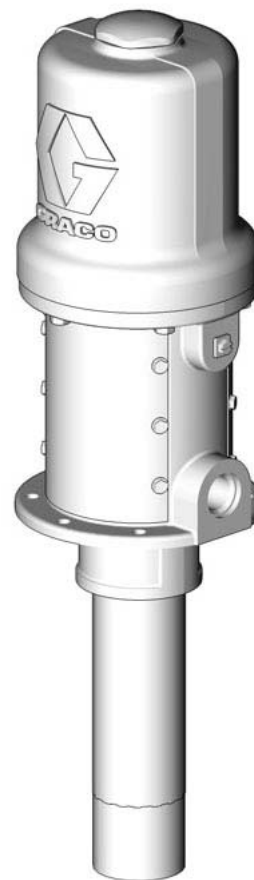

Warnings	2
Installation	4
Operation	6
Troubleshooting	7
Air Motor and Throat Service	8
Displacement Pump Service	12
Parts	14
Technical Data	16
Performance Chart	16
Dimensional Drawings	17
Mounting Hole Layout	17
Graco Standard Warranty	18
Graco Information	18







ti4062b

Warnings

The following warnings are for the setup, use, grounding, maintenance, and repair of this equipment. The exclamation point symbol alerts you to a general warning and the hazard symbol refers to procedure-specific risk. Refer back to these warnings. Additional, product-specific warnings may be found throughout the body of this manual where applicable.

 WARNING	
	<p>Equipment Misuse Hazard Misuse can cause death or serious injury.</p> <ul style="list-style-type: none"> Do not exceed the maximum working pressure or temperature rating of the lowest rated system component. See Technical Data in all equipment manuals. Use fluids and solvents that are compatible with equipment wetted parts. See Technical Data in all equipment manuals. Read fluid and solvent manufacturer's warnings. Check equipment daily. Repair or replace worn or damaged parts immediately. Do not alter or modify equipment. Use equipment only for its intended purpose. Call your Graco distributor for information. For professional use only. Route hoses and cables away from traffic areas, sharp edges, moving parts, and hot surfaces. Do not use hoses to pull equipment. Comply with all applicable safety regulations.
	<p>PRESSURIZED EQUIPMENT HAZARD Fluid from the gun/dispense valve, leaks, or ruptured components can splash in the eyes or on skin and cause serious injury.</p> <ul style="list-style-type: none"> Follow Pressure Relief Procedure in this manual, when you stop spraying and before cleaning, checking, or servicing equipment. Tighten all fluid connections before operating the equipment. Check hoses, tubes, and couplings daily. Replace worn or damaged parts immediately.
 	<p>SKIN INJECTION HAZARD High-pressure fluid from gun, hose leaks, or ruptured components will pierce skin. This may look like just a cut, but it is a serious injury that can result in amputation. Get immediate surgical treatment.</p> <ul style="list-style-type: none"> Do not point gun at anyone or at any part of the body. Do not put your hand over the spray tip. Do not stop or deflect leaks with your hand, body, glove, or rag. Do not spray without tip guard and trigger guard installed. Engage trigger lock when not spraying. Follow Pressure Relief Procedure in this manual, when you stop spraying and before cleaning, checking, or servicing equipment.

 WARNING	
	<p>MOVING PARTS HAZARD Moving parts can pinch or amputate fingers and other body parts.</p> <ul style="list-style-type: none"> • Keep clear of moving parts. • Do not operate equipment with protective guards or covers removed. • Pressurized equipment can start without warning. Before checking, moving, or servicing equipment, follow the Pressure Relief Procedure in this manual. Disconnect power or air supply.
	<p>TOXIC FLUID OR FUMES HAZARD Toxic fluids or fumes can cause serious injury or death if splashed in the eyes or on skin, inhaled, or swallowed.</p> <ul style="list-style-type: none"> • Read MSDS's to know the specific hazards of the fluids you are using. • Store hazardous fluid in approved containers, and dispose of it according to applicable guidelines.
	<p>FIRE AND EXPLOSION HAZARD Flammable fumes, such as solvent and paint fumes, in work area can ignite or explode. To help prevent fire and explosion:</p> <ul style="list-style-type: none"> • Use equipment only in well ventilated area. • Eliminate all ignition sources; such as pilot lights, cigarettes, portable electric lamps, and plastic drop cloths (potential static arc). • Keep work area free of debris, including solvent, rags and gasoline. • Do not plug or unplug power cords or turn lights on or off when flammable fumes are present. • Ground equipment and conductive objects. See Grounding instructions. • Use only grounded hoses. • Hold gun firmly to side of grounded pail when triggering into pail. • If there is static sparking or you feel a shock, stop operation immediately. Do not use equipment until you identify and correct the problem.

Installation

The typical stationary installation shown in FIG. 1 is only a guide for selecting and installing a pump. It is not an

actual system design. Contact your Graco distributor for assistance in designing a system to meet your needs.

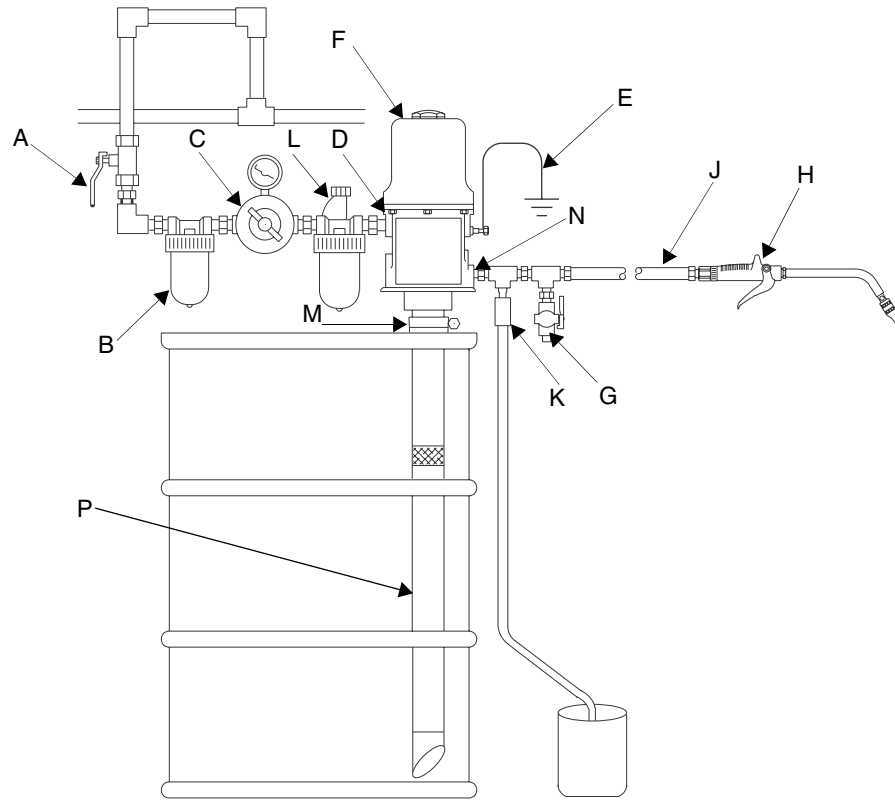

Key

- A** Bleed-type master air valve
- B** Air line filter
- C** Air regulator and gauge
- D** Air inlet
- E** Ground wire
- F** Pump
- G** Drain valve

- H** Dispensing valve
- J** Fluid hose
- K** Thermal relief kit (235998)
- L** Air line lubricator
- M** Bung adapter
- N** Fluid outlet
- P** Extension tube

FIG. 1

Mounting the Pump

					
<p>Mount the pump securely so that it cannot move during operation. Failure to do so could result in personal injury or equipment damage.</p>					

- Select a location that allows the operator easy access to the pump and air controls, sufficient room to change supply containers, and a secure mounting platform.
- If you are mounting the pump directly on the supply container, be sure it is positioned so the pump's intake tube is no more than **1 in. (25 mm)** from the bottom of the container. Mount the pump to the cover or other suitable mounting device.

 To prevent damage to the pump, remove sediment from the bottom of the container before installing a pump in an existing container.

Grounding

Proper grounding is essential to maintaining a safe system.

To reduce the risk of static sparking, ground the pump. Check local electrical codes for detailed grounding instructions for your area and equipment type. Be sure the following equipment is properly grounded:

- *Pump:* See FIG. 2.
- *Air and fluid hoses:* Use only electrically conductive hoses.
- *Air compressor:* Follow manufacturer's recommendations.
- *Dispensing valve:* Obtain grounding through connection to a properly grounded fluid hose and pump.
- *Fluid supply container:* Follow your local code.
- *Object being lubricated:* Follow your local code.

- *Any pails used when flushing:* Use only metal, grounded pails when flushing. Make firm metal-to-metal contact between a metal part of the dispensing valve and the pail. Use the lowest possible pressure.

To maintain grounding continuity when flushing or relieving pressure, always hold a metal part of the valve firmly to the side of a grounded metal pail, then trigger the valve.

To ground the pump, remove the ground screw (Z) and insert through the eye of the ring terminal at end of ground wire, (Y). Fasten the ground screw back onto the pump and tighten securely. Connect the other end of the ground wire to a true earth ground. See FIG. 2. To order a ground wire and clamp order Part No. 222011.

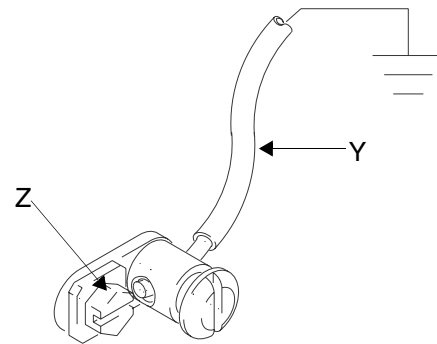



T11052

FIG. 2

Operation

See FIG. 1 to identify references shown in parentheses, i.e., (A).

						
---	---	---	--	--	--	--

This equipment stays pressurized until pressure is manually relieved. Read PRESSURIZED EQUIPMENT HAZARD warnings on page 2.

Maximum working pressure of all components in the system may not be the same. To reduce risk of overpressurizing any component, be sure you know the maximum working pressure of each component. Never exceed the maximum working pressure of the lowest rated component in the system. Overpressurizing any component can result in rupture, fire, explosion, property damage, and serious injury.

To determine the fluid output pressure using the air regulator reading, multiply the ratio of the pump by the air pressure shown on the regulator gauge. For example:

3:1 ratio x 100 psi air = 300 psi fluid output

Limit the air pressure to the pump so that no air line or fluid line component is overpressurized.

3. Open the pump air regulator (C) slowly, just until the pump is running. When the pump is primed and all air has been pushed out of the lines, close the dispensing valve (H).

NOTE: When the pump is primed, and with sufficient air supplied, the pump starts when the dispensing valve (H) is opened, and shuts off when it is closed.

4. Adjust the air regulator (C) until you get sufficient flow from dispensing valve (H). Always run the pump at the lowest pressure necessary to get the desired results. Do not exceed the maximum working pressure of any component in the system.

CAUTION

Never allow the pump to run dry of the fluid being pumped. A dry pump will quickly accelerate to a high speed, possibly causing pump damage. It may also get very hot.

5. If your pump accelerates quickly or is running too fast, stop it immediately and check the fluid supply. If the supply container is empty and air has been pumped into the lines, prime the pump and lines with fluid, or flush it and leave it filled with a compatible solvent. Be sure to eliminate all air from the fluid lines.
6. Read and follow the instructions supplied with each component in your system.
7. If the pump will be unattended for any period of time, if there is an air supply interruption, or at the end of the work shift, shut off the system and always **relieve the pressure.**

Pressure Relief Procedure

1. Close the pump air regulator (C) and the bleed-type master air valve (A), required in your system.
2. Hold a metal part of the dispensing valve (H) firmly to a grounded metal waste container, and trigger the valve to relieve fluid pressure.

Starting and Adjusting the Pump

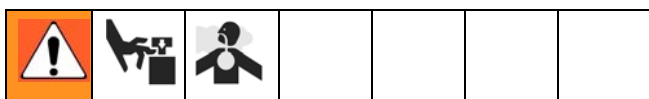

1. With the air regulator (C) closed, open the bleed-type master air valve (A).
2. Open the dispensing valve (H) into a grounded metal waste container, making firm metal-to-metal contact between the container and valve.

Troubleshooting

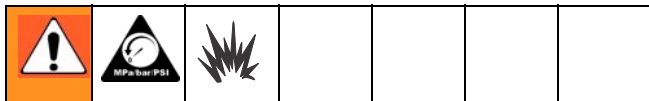

 Check all other possible problems and solutions before disassembling the pump. Before you troubleshoot problems using the table below, relieve the pressure and disconnect the pump fluid line. If the pump starts when the air is turned on again, the fluid line, dispensing valve, etc., is clogged.

Problem	Cause	Solution
Pump fails to operate	Inadequate air supply pressure or restricted air lines	Increase air supply; clear
	Closed or clogged dispensing valve	Open; clear
	Clogged fluid lines, hoses, valve, etc.	Clear
	Damaged air motor	Service air motor
	Exhausted fluid supply	Refill and reprime or flush
Continuous air exhaust	Worn or damaged air motor gasket, packing, seal, etc.	Service air motor
Erratic pump operation	Exhausted fluid supply	Refill and reprime or flush
Pump operates, but output low on down stroke	Held open or worn intake valve or piston packings	Clear; service
Pump operates, but output low on up stroke	Held open or worn piston ball or piston packings	Clear; service
Pump operates, but output low on both strokes	Inadequate air supply pressure or restricted air lines	Increase air supply; clear
	Closed or clogged valves	Open; clean
	Exhausted fluid supply	Refill and reprime or flush
	Clogged fluid lines, hoses, valves, etc.	Clear



Air Motor and Throat Service

Before You Start

- Be sure you have all necessary parts on hand. Pump Repair Kit 246918 includes repair parts for the pump and air motor. Use all the parts in the kit for the best results. Parts included in the kit are marked with one asterisk, for example (17*), in the text and drawings. See **Parts**, page 14.
- Two accessory tools should be used: **Padded Pliers, 248198**, are used to grip the trip rod without damaging its surface. **Gauge, 15E796**, is used to ensure the proper clearance between the poppets and seat of the transfer valve.

Disassembly

1. Flush the pump, and relieve the pressure.

						
To reduce the risk of serious injury whenever you are instructed to relieve pressure, always follow the Pressure Relief Procedure on page 6.						

2. Disconnect the ground wire from the grounding screw (28a), disconnect the hoses, remove the pump from its mounting, and clamp the air motor base in a vise horizontally by closing the vice jaws on the flange.
3. Use a strap wrench on the fluid cylinder (105) to screw it out of the air motor base (28). See **Parts**, page 14.
4. Pull the displacement rod (29) down as far as it will go. See FIG. 3.
5. Using wrenches on the flats of the displacement rod (29) and on the flats of the fluid piston (107), unscrew the fluid piston from the displacement rod. Remove the ball (100) from the end of the displacement rod, and remove the packing o-ring (102*) from the fluid piston. See **Parts**, page 14.
6. Clamp the air motor upright in the vise by closing the vice jaws below the flange.
7. Unscrew the cylinder cap nut (39) from the top of the air motor cylinder (35).

8. Pull up on the cylinder cap nut (39) to expose the trip rod, grasp the trip rod with padded pliers (*Part No. 248198*), and unscrew the cylinder cap nut from the trip rod.

CAUTION
Do not damage the plated surface of the trip rod (40). Damaging the surface of the trip rod can result in erratic air motor operation. Use the special padded pliers to grasp the rod.

9. Remove the six screws (9) holding the air motor cylinder (35) to the air motor base (28), and carefully pull the cylinder straight up off of the piston (34).

CAUTION
To avoid damaging the cylinder wall, lift the cylinder straight up off of the piston. Never tilt the cylinder while you are removing it.

10. Pull the air motor piston/displacement rod assembly (29, 34) clear of the air motor base (28) by pulling up on the air motor piston.
11. Remove the o-rings (13*, 103*) and u-cup packing (16*) from the air motor base (28). Use needle-nose pliers to remove the u-cup packing from the bottom of the air motor base.

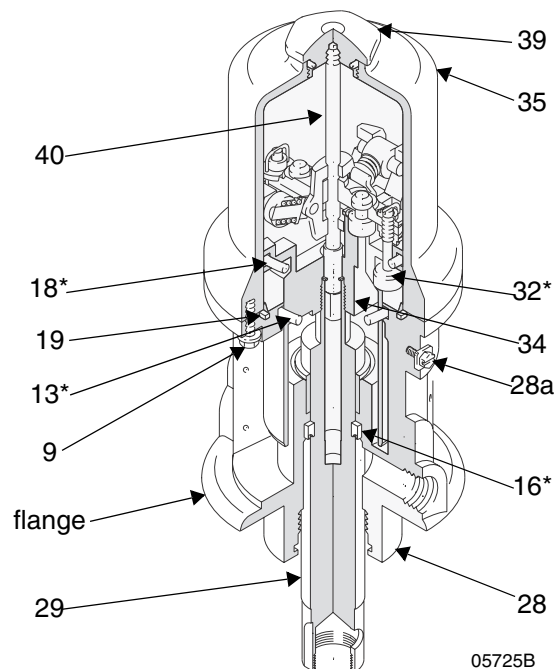
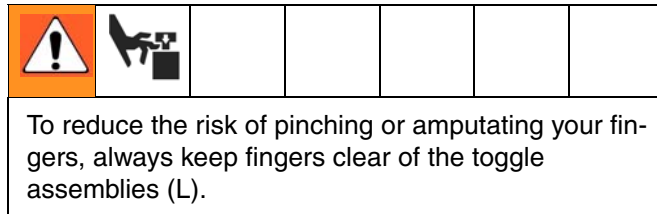



FIG. 3

12. Remove the o-ring (18*) from the air motor piston (34).
13. Clamp the displacement rod upright in the vice by closing the vice jaws on the flats of the displacement rod.
14. Use a screwdriver to push down on the trip rod yoke (23) to snap the toggle assemblies (L) down. See FIG. 4.
15. Remove the lockwires (25*) from the adjusting nuts (24*) of the transfer valves. Screw the top nuts off. Screw the valve poppet (32*) stems out of the grommets (17*) and bottom nuts (24*). Take the valve poppets off of the stems, and squeeze them firmly to check for cracks.
16. Grip the toggle arms (38) with pliers. Compress the springs (20) and swing the toggle assembly (L) up and away from the piston lugs (M), and remove the assembly. Check that the valve actuator (27) is supported by the spring clips (26), but slides easily into them. See Fig. 4.



17. Remove the trip rod yoke (23), actuator (27), and trip rod (40). Check the exhaust valve poppets (31*) for cracks.

 To remove the exhaust valve poppets (31*), stretch them out and cut the end off with a sharp knife.

Clean and Service

1. Clean all the parts carefully in a compatible solvent and inspect for wear or damage. Use all the repair kit parts during reassembly, and replace other parts as necessary.
2. Check the polished surfaces of the air motor piston (34), displacement rod (29), and cylinder wall (35) for scratches or wear. A scored rod will cause premature packing wear and leaking.
3. Lubricate all parts with a light weight, water-resistant grease.

Reassembly

1. Clamp the displacement rod (29) upright in the vice by closing the vice jaws on the flats of the displacement rod.
2. Pull the new exhaust valve poppets (31*) into the valve actuator (27), and clip off the top parts of the poppets (shown with dotted lines in the **Cutaway View** in Fig. 4).
3. Install the new grommets (17*) in the actuator (27), place the inlet valve poppets (32*) in the piston, and thread the bottom valve nuts (24*) onto the stems of the inlet valve poppets until there are a few threads left before the threads run out.

 If you thread the valve nuts too far down onto the poppets, they will run off the threaded part of the poppets.

4. Grease heavily and place the trip rod (40) in the air motor piston (34), place the actuator (27) in the yoke (23), and place the well-greased actuator/yoke assembly in the piston, with the trip rod going through the center holes of the actuator and yoke and the stems of the inlet valve poppets (32*) going through the grommets (17*).
5. Thread the top valve nuts (24*) onto the stems of the inlet valve poppets (32*) until one thread of the inlet valve poppets is exposed above the valve nuts.
6. Install the toggle pins (36) in the yoke (23), place the toggle arm (38) ends of the toggle assembly (L) onto the toggle pins, and snap the pivot pin (37) ends of the toggle assembly into the piston lugs (M).
7. Measuring with the gauge (*Part No. 15E796*), create 0.105 in. (2.7 mm) of clearance between the inlet valve poppets (32*) and the piston seat when the inlet valve is open. See the **Cutaway View** in Fig. 4.

 Adjust the distance between the inlet valve poppets and the piston seat by turning the top valve nuts (24*).

8. Tighten the bottom valve nuts (24*) by hand. The grommets (17*) should be slightly compressed.

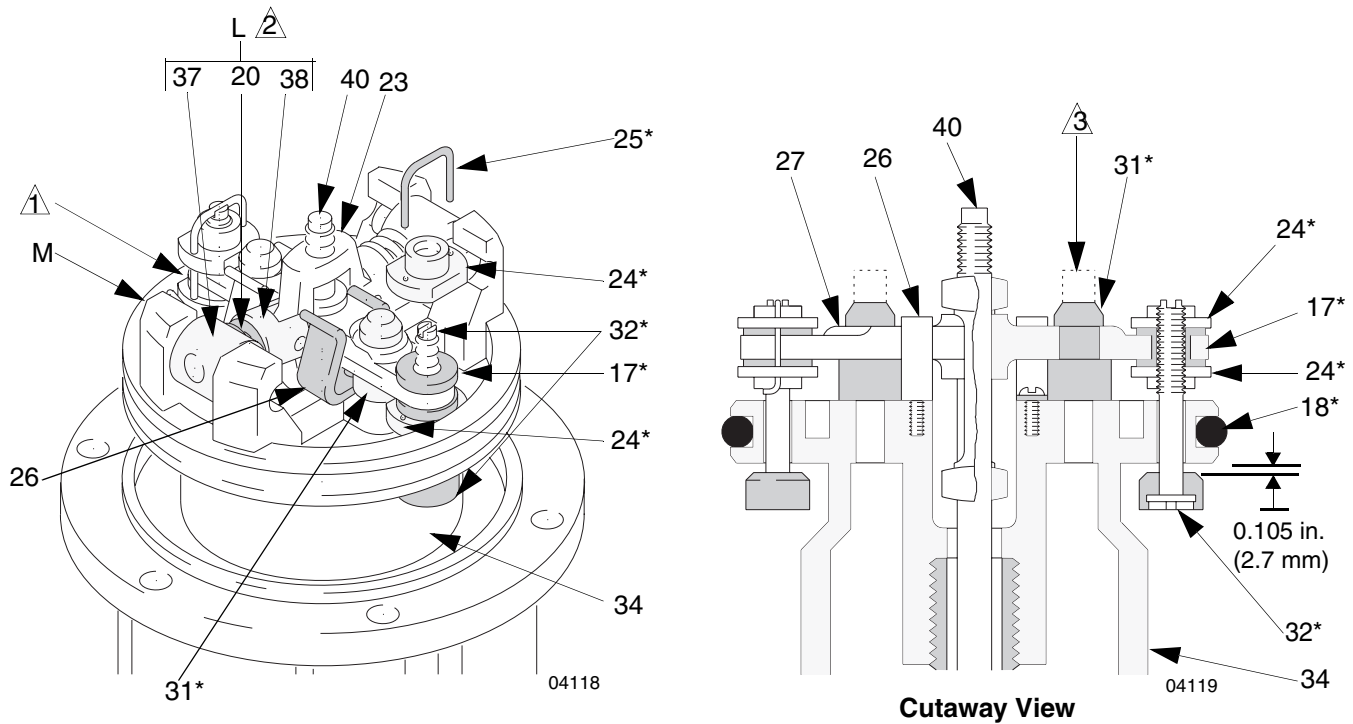

- 1 Turn wires up.
- 2 Push toggles (L) in and then up.
- 3 Cut off tops of poppets as indicated by dotted lines.

FIG. 4

CAUTION

Never re-use the old lock wires. They will get brittle and break easily from too much bending.

9. Align the holes in the valve nuts (24*) and the slots on the stems of the inlet valve poppets (32*). Drop the lock wires (25*) through the holes in the valve nuts and into the slots in the stems of the inlet valve poppets. Pull the lock wires down tightly, and bend the ends with pliers so that they cannot be pulled back out of the holes.
10. Take the assembly out of the vice so that you can move it around for steps 11 and 12.
11. Grease and install the new o-rings (13*, 18*, 103*).
12. Install the new u-cup packing (16*) through the bottom of the air motor base, with the lips facing toward the bottom of the pump.

13. Slide the displacement rod (29) down through the packings, and lower the air motor piston (34) into the air motor base (28).
14. Clamp the air motor upright in the vice by closing the vice jaws below the flange.
15. Carefully lower the air motor cylinder (35) straight down onto the piston assembly (34). Tighten the six screws (9) holding the air motor cylinder to the air motor base (28).

CAUTION

To avoid damaging the cylinder wall, lower the cylinder straight down onto the piston. Never tilt the cylinder as it is being lowered.

- Pull the trip rod (40) so it is sticking up out of the air motor cylinder (35).



 You may have to hold the unit upside down to shake the trip rod loose.

- Grip the trip rod (40) with padded pliers, screw the cylinder cap nut (39) onto the trip rod, push the cylinder cap nut down, and screw it into the top of the cylinder.

CAUTION
Do not damage the plated surface of the trip rod (40). Damaging the surface of the trip rod can result in erratic air motor operation. Use the special padded pliers to grasp the rod.

- Place the piston ball (100) in the displacement rod (29).
- Clean the threads of the fluid piston (107), apply Loctite[®] to the threads, install the new packing o-ring (102*) on the fluid piston, and thread the fluid piston onto the displacement rod (29).

- Clamp the flats of the fluid piston (107) in a vice, and torque the displacement rod (29) to the piston to 40 to 60 ft-lb (54 to 81 N•m).
- Clamp the air motor base (28) in a vise horizontally by closing the vice jaws on the flange.
- Use a strap wrench to screw the displacement pump cylinder (105) to the air motor base (28), and torque to 40 to 60 ft-lb (54 to 81 N•m).
- Before remounting the pump, connect an air hose and run the air motor slowly, starting with just enough air pressure to make the air motor run, and make sure that it operates smoothly.



						
Never operate the pump with the warning plate (47) or the identification plate (46) removed. These plates protect your fingers from getting pinched or amputated by moving parts in the air motor.						

- Reconnect the ground wire before you resume regular pump operation.

Displacement Pump Service

Be sure you have all necessary parts on hand. **Pump Repair Kit 246918** includes repair parts for the pump and air motor. Use all of the parts in the kit for the best results. Parts included in the kit are marked with one asterisk, for example (13*), in the text and drawings. See **Parts**, page 14.

1. Flush the pump and **relieve the pressure**.

						
To reduce the risk of serious injury whenever you are instructed to relieve pressure, always follow the Pressure Relief Procedure on page 6.						

2. Disconnect the hoses, remove the pump from its mounting, and clamp the air motor base in a vise horizontally by closing the vice jaws on the flange.
3. Unscrew the intake valve housing (106) from the fluid cylinder (105). Disassemble the intake valve (see **Parts**, page 14). Clean and inspect the parts for wear or damage, and replace parts as needed. Be sure to check the o-ring (104*). Unless further intake valve service is needed, reassemble and reinstall, using liquid sealant on the male threads.
4. Use a strap wrench on the fluid cylinder (105) to screw it out of the air motor base (28). Carefully inspect the smooth inner surface of the cylinder for scoring or irregular surfaces. Such damage causes premature packing wear and leaking, so replace the part if it is damaged.

5. Using wrenches on the flats of the displacement rod (29) and on the flats of the fluid piston (107), unscrew the fluid piston from the displacement rod.
6. Take the piston ball (100) out of the displacement rod (29), and take the packing o-ring (102*) off of the fluid piston (107).
7. Clean and inspect the parts. Use all the repair kit parts during reassembly, and replace other parts as necessary.
8. Place the piston ball (100) in the displacement rod (29).
9. Install the new packing o-ring (102*) on the fluid piston (107).
10. Clamp the flats of the fluid piston (107) in a vise and torque the displacement rod (29) to the piston to 40 to 60 ft-lb (54 to 81 N•m).
11. Clamp the air motor base (28) in a vise horizontally by closing the vice jaws on the flange.
12. Use a strap wrench to screw the fluid cylinder (105) to the air motor base (28), and torque to 40 to 60 ft-lb (54 to 81 N•m).
13. If you disconnected the ground wire, reconnect it before you resume regular pump operation.

Parts

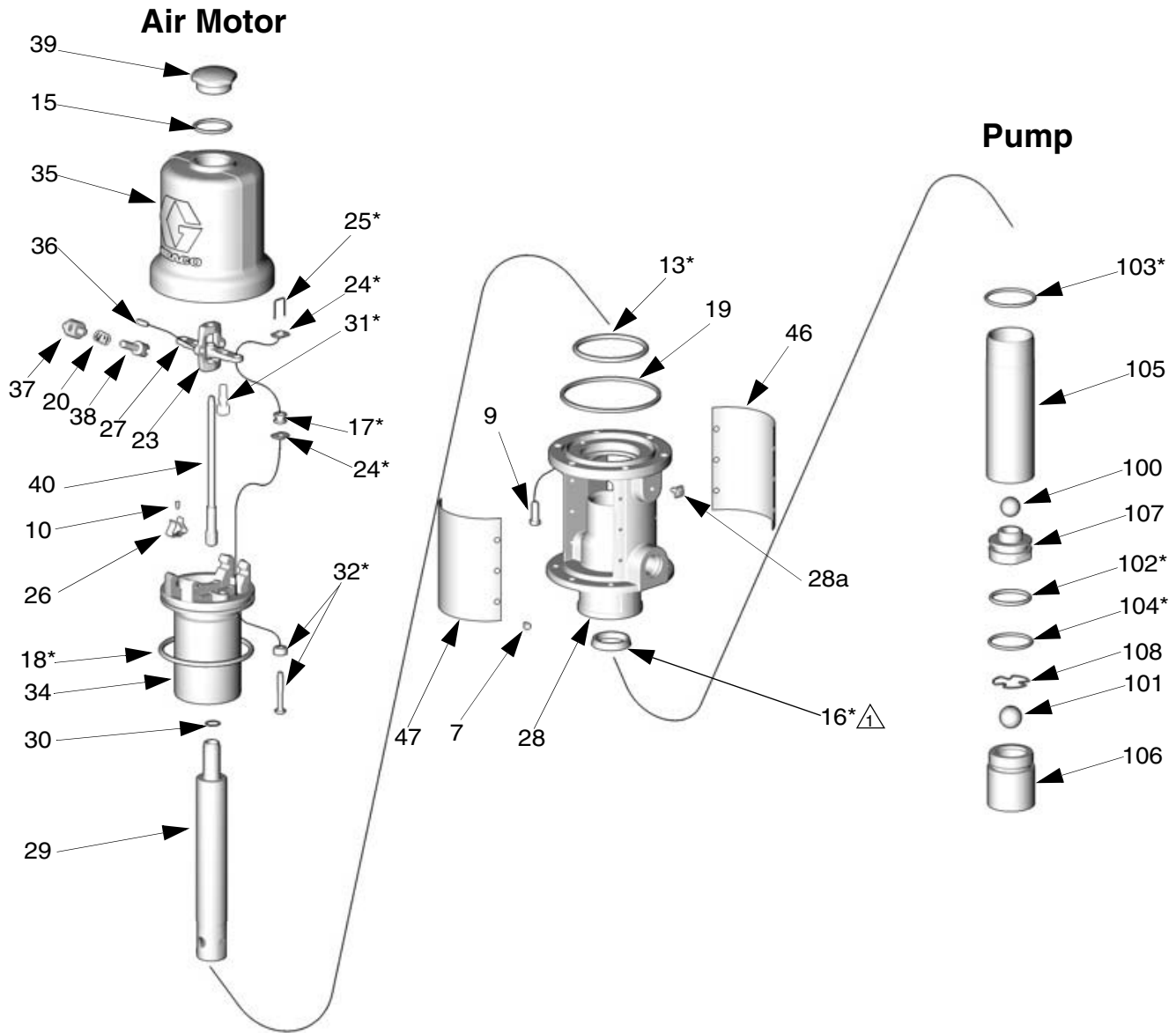

⚠ Lips face down.

T14016b

Model No. 246775, Series B, Universal Model No. 248097, Series B, Variable Length

Air Motor

Ref. No.	Part No.	Description	Qty.
7	100078	SCREW, thread forming, hex head 8-32 x 3/8 in.	12
9	101578	CAPSCREW, hex head, 8-32 x 3/8 in.	6
10	118718	SCREW, machine	2
13*	113347	O-RING, buna-N	1
15	156698	O-RING, buna-N	1
16*	118106	PACKING, u-cup	1
17*	118107	GROMMET, lower valve	2
18*	118108	PACKING, o-ring	1
19	118109	PACKING, square	1
20	118111	SPRING, compression, helical	1
23	15C245	YOKE, rod, trip	1
24*	15C246	NUT, valve	4
25*	15C247	WIRE, lock	2
26	15C248	CLIP, spring	2
27	15C249	ACTUATOR, valve	1
28	253580	BASE, motor, air (includes 28a)	1
28a	116343	SCREW, grounding	1
29	15C252	ROD, displacement, mp	1
30	15C266	GASKET, copper	1
31*	15C267	POPPET, valve, exhaust	2
32*	248211	POPPET, valve, inlet**	2
34	15W205	PISTON, motor, air 2-1/4"	1
35	15C274	CYLINDER, motor, air	1
36	15C275	PIN, toggle	2
37	15C276	PIN, pivot	2
38	15C277	ARM, toggle	2
39	15C278	NUT, cap, cylinder	1
40	15C279	ROD, trip	1
46	246782	PLATE, muffler, serial number	1
47	246783	PLATE, muffler, warning	1

Pump

Ref. No.	Part No.	Description	Qty.
100	100400	BALL, piston, metallic, 3/4 in.	1
101	100279	BALL, metallic, 7/8 in.	1
102*	107227	O-RING, buna-N	1
103*	107306	O-RING, fluoroelastomer	1
104*	157195	O-RING, buna-N	1
105	15C499	CYLINDER, fluid	1
106	15C500	HOUSING, valve, intake	1
107	15C501	PISTON, fluid	1
108	15C533	RETAINER, ball	1
109	15C502	TUBE, extension, variable length, Model 248097 only, (not shown)	1
110	222308	ADAPTER, bung, Model 248097 only, (not shown)	1

*Included in Pump Repair Kit 246918.

** Use gap adjustment tool 15E796 (also included in Repair Kit 246918) to ensure correct gap setting for poppets.

Technical Data

(Data measured with 10 weight oil at 70°F (21°C))

Fluid to air ratio.....	3:1
Cycles/gallon (cycles/liter).....	43.5 (11.4)
Fluid flow @80 cpm (gpm/lpm).....	1.84 (7.0)
Pumping distance guideline.....	up to 250 ft. (76.2 m)
Maximum fluid pressure	540 psi (3.7 MPa, 37 bar)
Air motor effective diameter.....	2.25 in. (57.2 mm)
Air operating range	40-180 psi (0.28-1.2 MPa, 2.8-12 bar)

Approx. air consumption and fluid flow @ 100 psi air and 80 cpm	8.5 scfm @2.1 gpm (.241 m ³ /min @7.9 lpm)
Dry suction lift (feet of water)	23
Wetted materials	steel, polyurethane, aluminum, buna-N, Rulon®
Air inlet port size	3/8 in. npt(f)
Fluid inlet port size	1.5 in. npt(f)
Fluid outlet port size.....	1/2 in. npt(f)
Sound pressure (measured 1 meter from unit) ..	77.8 dB
Sound pressure (ISO 9614-2).....	85.6 dB

Performance Chart

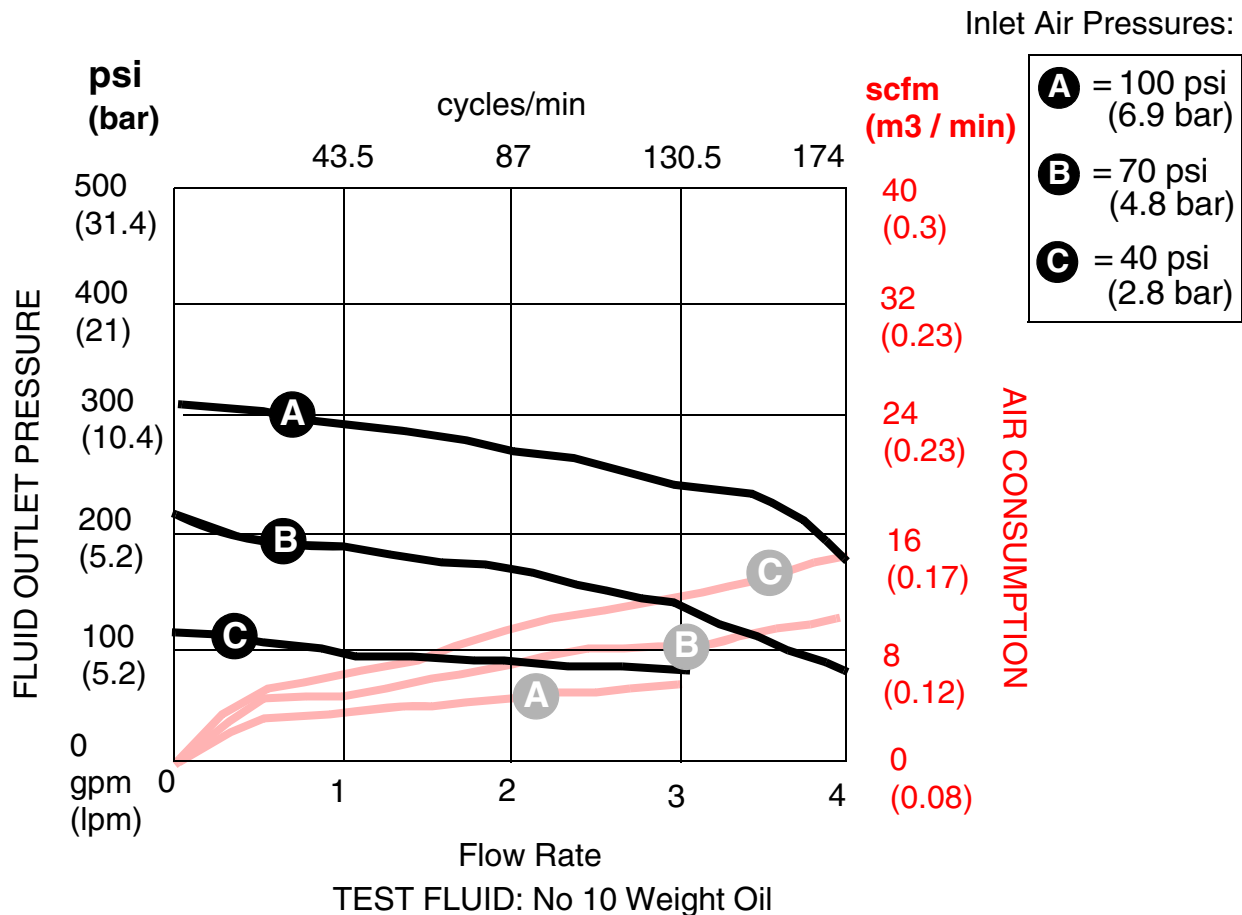

Dimensional Drawings

Model 246775

Universal

Overall Length: 18.9 in. (48 cm)

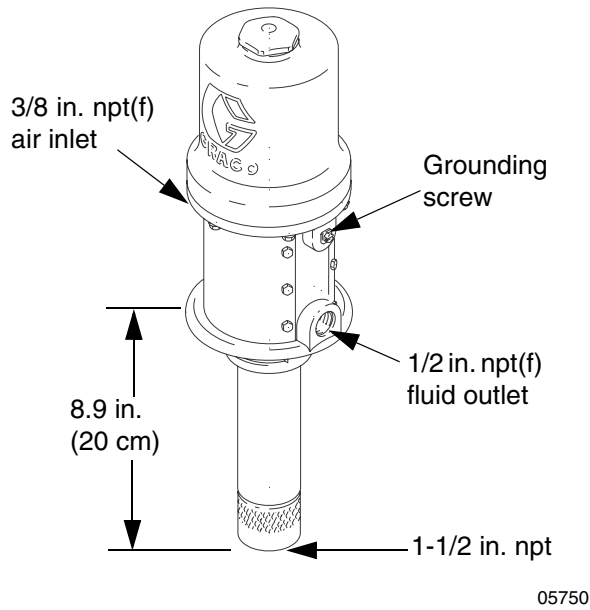

Model 248097

Variable length

Overall Length: 59.2 in. (150.4 cm)

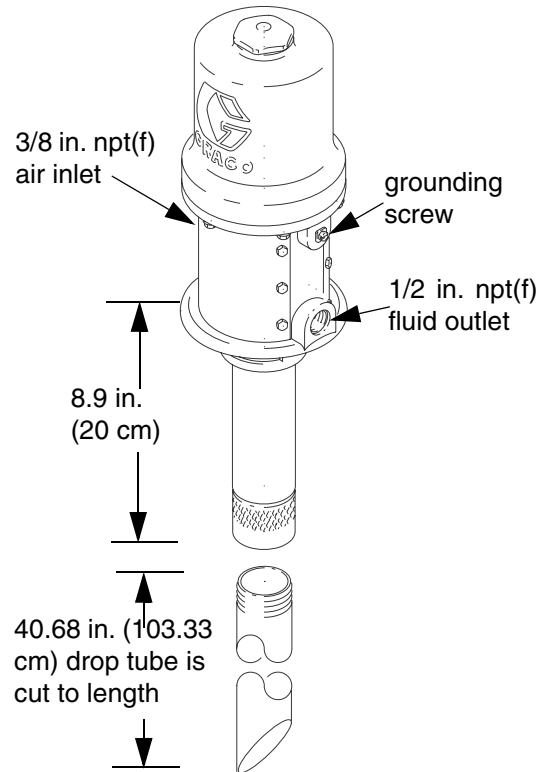

Mounting Hole Layout

Pump Base

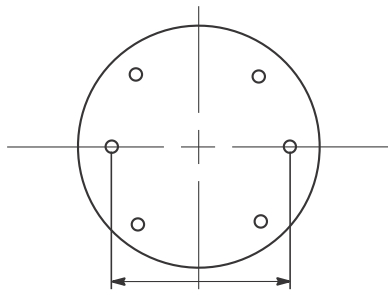

4.250 in. (10.8 cm) bolt circle
0.281 in. (7.1 mm) diameter clearance holes

Order gasket 15R881 for sealed tank/drum mounting.

2.518 in. (6.4 cm) dia.

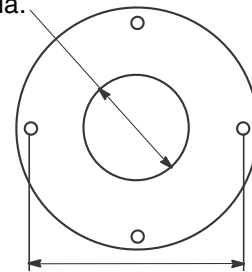

4.250 in. (10.8 cm) bolt circle
0.266 in. (6.7 mm) diameter clearance holes

Graco Standard Warranty

Graco warrants all equipment referenced in this document which is manufactured by Graco and bearing its name to be free from defects in material and workmanship on the date of sale to the original purchaser. With the exception of any special, extended, or limited warranty published by Graco, Graco will, for a period of twelve months from the date of sale, repair or replace any part of the equipment determined by Graco to be defective. This warranty applies only when the equipment is installed, operated and maintained in accordance with Graco's written recommendations.

This warranty does not cover, and Graco shall not be liable for general wear and tear, or any malfunction, damage or wear caused by faulty installation, misapplication, abrasion, corrosion, inadequate or improper maintenance, negligence, accident, tampering, or substitution of non-Graco component parts. Nor shall Graco be liable for malfunction, damage or wear caused by the incompatibility of Graco equipment with structures, accessories, equipment or materials not supplied by Graco, or the improper design, manufacture, installation, operation or maintenance of structures, accessories, equipment or materials not supplied by Graco.

This warranty is conditioned upon the prepaid return of the equipment claimed to be defective to an authorized Graco distributor for verification of the claimed defect. If the claimed defect is verified, Graco will repair or replace free of charge any defective parts. The equipment will be returned to the original purchaser transportation prepaid. If inspection of the equipment does not disclose any defect in material or workmanship, repairs will be made at a reasonable charge, which charges may include the costs of parts, labor, and transportation.

THIS WARRANTY IS EXCLUSIVE, AND IS IN LIEU OF ANY OTHER WARRANTIES, EXPRESS OR IMPLIED, INCLUDING BUT NOT LIMITED TO WARRANTY OF MERCHANTABILITY OR WARRANTY OF FITNESS FOR A PARTICULAR PURPOSE.

Graco's sole obligation and buyer's sole remedy for any breach of warranty shall be as set forth above. The buyer agrees that no other remedy (including, but not limited to, incidental or consequential damages for lost profits, lost sales, injury to person or property, or any other incidental or consequential loss) shall be available. Any action for breach of warranty must be brought within two (2) years of the date of sale.

GRACO MAKES NO WARRANTY, AND DISCLAIMS ALL IMPLIED WARRANTIES OF MERCHANTABILITY AND FITNESS FOR A PARTICULAR PURPOSE, IN CONNECTION WITH ACCESSORIES, EQUIPMENT, MATERIALS OR COMPONENTS SOLD BUT NOT MANUFACTURED BY GRACO. These items sold, but not manufactured by Graco (such as electric motors, switches, hose, etc.), are subject to the warranty, if any, of their manufacturer. Graco will provide purchaser with reasonable assistance in making any claim for breach of these warranties.

In no event will Graco be liable for indirect, incidental, special or consequential damages resulting from Graco supplying equipment hereunder, or the furnishing, performance, or use of any products or other goods sold hereto, whether due to a breach of contract, breach of warranty, the negligence of Graco, or otherwise.

FOR GRACO CANADA CUSTOMERS

The Parties acknowledge that they have required that the present document, as well as all documents, notices and legal proceedings entered into, given or instituted pursuant hereto or relating directly or indirectly hereto, be drawn up in English. Les parties reconnaissent avoir convenu que la rédaction du présente document sera en Anglais, ainsi que tous documents, avis et procédures judiciaires exécutés, donnés ou intentés, à la suite de ou en rapport, directement ou indirectement, avec les procédures concernées.

Graco Information

For the latest information about Graco products, visit www.graco.com.

TO PLACE AN ORDER, contact your Graco distributor or call to identify the nearest distributor.

Phone: 612-623-6928 or **Toll Free:** 1-800-533-9655, **Fax:** 612-378-3590

*All written and visual data contained in this document reflects the latest product information available at the time of publication.
Graco reserves the right to make changes at any time without notice.*

Original instructions. This manual contains English. MM 309868

Graco Headquarters: Minneapolis

International Offices: Belgium, China, Japan, Korea

GRACO INC. P.O. BOX 1441 MINNEAPOLIS, MN 55440-1441

Copyright 2004, Graco Inc. is registered to ISO 9001

www.graco.com

Revised 03/2010