



Dyna-Star[®] HP and HF Pump Auto-Fill[®] Shut Off Kit

332518C
EN

Used with Dyna-Star HP or HF Pump to fill Graco Tank/Reservoir. For automatic grease lubrication systems only. Cannot be used with pumps equipped with a dip stick, low level indicator or follower plate. For professional use only.



Important Safety Instructions







Read all warnings and instructions in this manual and the Dyna-Star HP and HF Pump instruction manual. Save all instructions.

*5000 psi (34.47 MPa, 344 bar) Maximum Lubricant Inlet Pressure
3/8 inch npt inlet and outlet
Maximum Flow: 2 gpm (7.57 lpm)*

Model: 77X521

Warnings

The following warnings are for the setup, use, grounding, maintenance, and repair of this equipment. The exclamation point symbol alerts you to a general warning and the hazard symbols refer to procedure-specific risks. When these symbols appear in the body of this manual or on warning labels, refer back to these Warnings. Product-specific hazard symbols and warnings not covered in this section may appear throughout the body of this manual where applicable.

 WARNING	
  	<p>SKIN INJECTION HAZARD</p> <p>High-pressure fluid from dispensing device, hose leaks, or ruptured components will pierce skin. This may look like just a cut, but it is a serious injury that can result in amputation. Get immediate surgical treatment.</p> <ul style="list-style-type: none"> • Do not point dispensing device at anyone or at any part of the body. • Do not put your hand over the fluid outlet. • Do not stop or deflect leaks with your hand, body, glove, or rag. • Follow the Pressure Relief Procedure when you stop dispensing and before cleaning, checking, or servicing equipment. • Tighten all fluid connections before operating the equipment. • Check hoses and couplings daily. Replace worn or damaged parts immediately.
 	<p>EQUIPMENT MISUSE HAZARD</p> <p>Misuse can cause death or serious injury.</p> <ul style="list-style-type: none"> • Do not operate the unit when fatigued or under the influence of drugs or alcohol. • Do not exceed the maximum working pressure or temperature rating of the lowest rated system component. See Technical Data in all equipment manuals. • Use fluids and solvents that are compatible with equipment wetted parts. See Technical Data in all equipment manuals. Read fluid and solvent manufacturer's warnings. For complete information about your material, request MSDS from distributor or retailer. • Turn off all equipment and follow the Pressure Relief Procedure when equipment is not in use. • Check equipment daily. Repair or replace worn or damaged parts immediately with genuine manufacturer's replacement parts only. • Do not alter or modify equipment. Alterations or modifications may void agency approvals and create safety hazards. • Make sure all equipment is rated and approved for the environment in which you are using it. • Use equipment only for its intended purpose. Call your distributor for information. • Route hoses and cables away from traffic areas, sharp edges, moving parts, and hot surfaces. • Do not kink or over bend hoses or use hoses to pull equipment. • Keep children and animals away from work area. • Comply with all applicable safety regulations.
	<p>PERSONAL PROTECTIVE EQUIPMENT</p> <p>Wear appropriate protective equipment when in the work area to help prevent serious injury, including eye injury, hearing loss, inhalation of toxic fumes, and burns. This protective equipment includes but is not limited to:</p> <ul style="list-style-type: none"> • Protective eyewear, and hearing protection. • Respirators, protective clothing, and gloves as recommended by the fluid and solvent manufacturers.

Auto-Fill Shut Off Overview

Reference letters used in the following instructions refer to Parts Table and Drawing shown on the cover of this manual.

The Auto-Fill Shut Off is used for refilling the grease tank/reservoir in an automatic lubrication system. As grease is added to the reservoir, it pushes the diaphragm up to the top of the reservoir. The diaphragm then pushes the valve pin and closes the inlet fluid path.

Pressure Relief



Follow the Pressure Relief Procedure whenever you see this symbol.



This equipment stays pressurized until pressure is manually relieved. To help prevent serious injury from pressurized fluid, such as skin injection, splashing fluid and moving parts, follow the Pressure Relief Procedure when you stop dispensing and before cleaning, checking, or servicing the equipment.

To relieve pressure in the system, use two wrenches working in opposite directions on pump outlet fitting to **slowly loosen fitting only** until fitting is loose and no more lubricant or air is leaking from fitting. See FIG. 1.

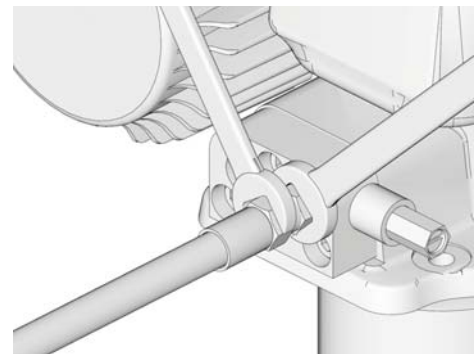

FIG. 1

Installation

Typical Installation

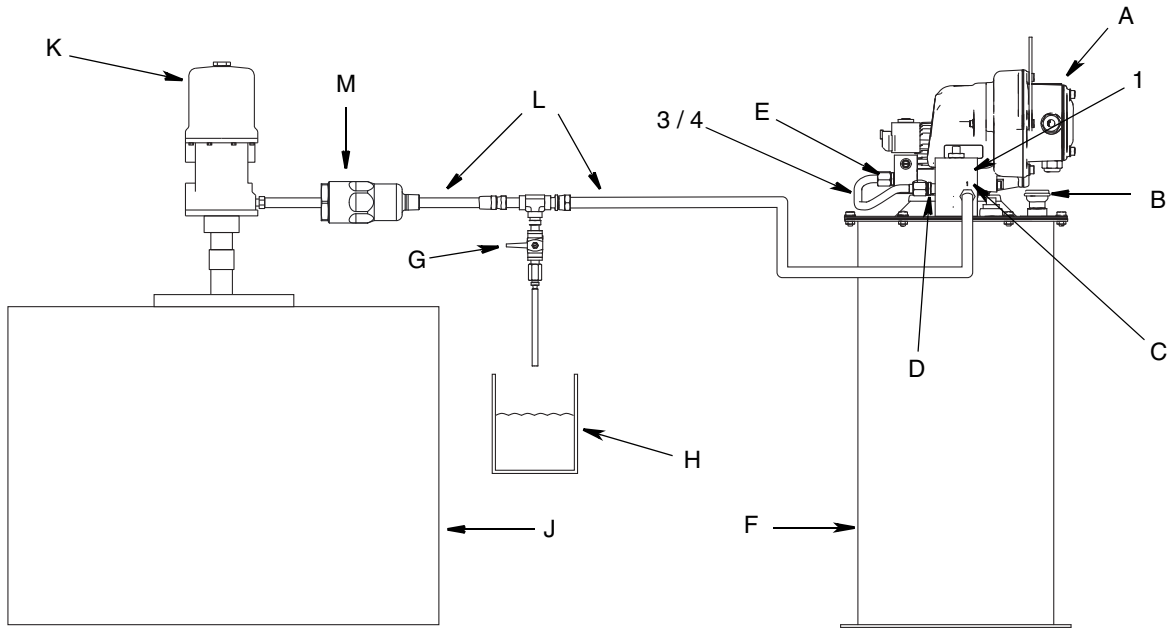

FIG. 2

- A Dyna-Star Pump
 - B Breather
 - C Auto-Fill Inlet
 - D Auto-Fill Outlet
 - E Pump Manifold / Vent Valve Inlet
 - F Reservoir
 - G Pressure Relief Valve (Required, user supplied)
 - H Fluid Overflow Container
 - J Remote Filling Station Reservoir
 - K Remote Filling Station Pump (pneumatic)
 - L Lubricant Supply Hose (Required, user supplied)
 - M Filter (recommended if grease/environment is contaminated)
-
- 1 Auto-Fill Shut Off
 - 3 Tube (vent valve)
 - 4 Tube (manifold)

Disassembly

NOTE:

- Reference numbers used in the following instructions refer to Kit Parts provided on the cover of this manual.
 - Upper case letters used in the following instructions refer to Typical Installation provided on page 4.
 - Lower case letters used in the following instructions refer to component parts or user provided parts not included in the Kit.
 - Steps 1 - 2 only apply to pumps that have already been in service and are adding an Auto-Fill Shut Off Valve. For new installations, begin instructions with Step 3.
1. Disconnect Dyna-Star pump (A) from main power source.
 2. **Relieve pressure** (see Pressure Relief procedure, page 3).
 3. Loosen bolts (a) and remove cover (b) from Dyna-Star pump (A) (FIG. 3). Save these parts to use for installation.

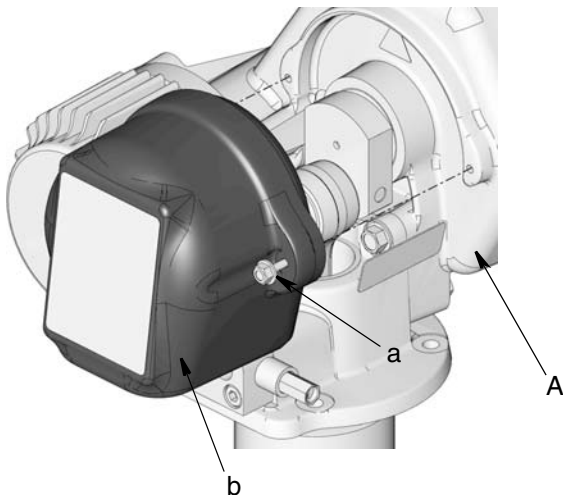

FIG. 3

4. Remove screws (c) and washers (d) holding Dyna-Star Pump (A) to cover (e) and remove pump from cover (FIG. 4). Save these parts to use for installation.

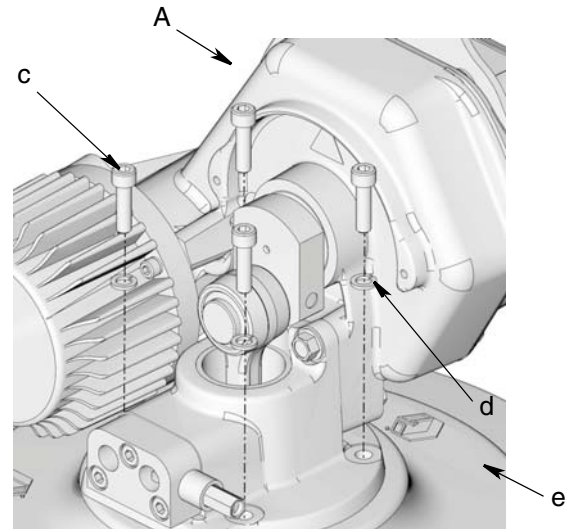

FIG. 4

5. Remove the bolts (g) and nuts (gg) (holding the cover (e) to the reservoir (F)) (FIG. 5). Save these parts to use for installation.

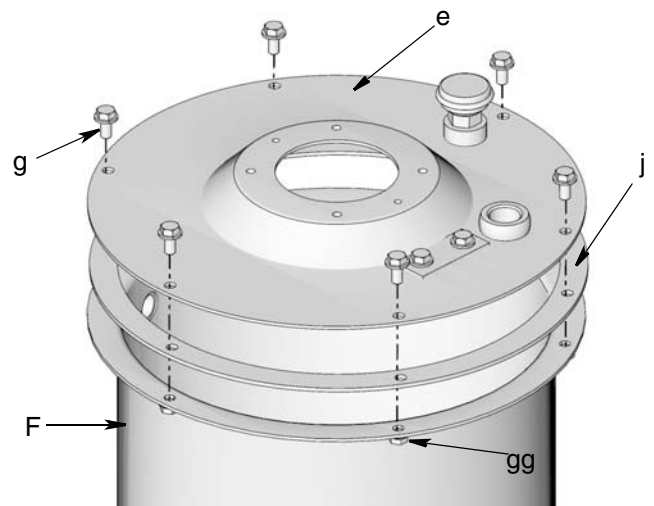

FIG. 5

6. Remove cover (e) and gasket (j) (FIG. 5). Save these parts to use for installation.
7. (If previously installed) remove follower plate and / or low level indicator or dipstick. Discard these parts according to applicable guidelines.

Reassembly

NOTE:

- Reference numbers used in the following instructions refer to Kit Parts provided on the cover of this manual.
 - Upper case letters used in the following instructions refer to Typical Installation provided on page 4.
 - Lower case letters used in the following instructions refer to component parts or user provided parts not included in the Kit.
1. Align diaphragm (2) on reservoir (F) (FIG. 6), matching holes around the rim of diaphragm with the holes in the top of the reservoir. Refer to FIG. 6 to determine the correct orientation of the diaphragm.

NOTE: The diaphragm (2) has six valves (not pictured). When the diaphragm is correctly installed, valves will face downward.

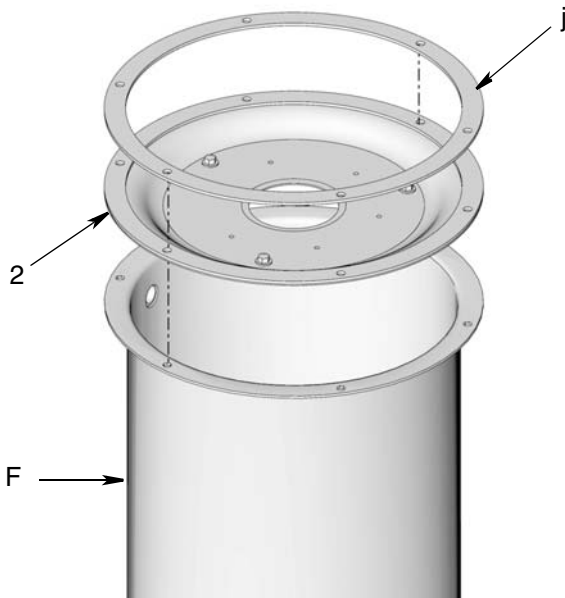

FIG. 6

2. Install gasket (j) removed in step 6, page 5 over the diaphragm (2) (FIG. 6), matching holes in gasket with the holes in rim of diaphragm.

3. Remove screws (k) and nuts (kk) from accessory cover plate (l) [installed on the pump reservoir cover (e)] (FIG. 7). Remove plate and gasket (m). Discard screws, nuts, plate and gasket, you will not use them again.

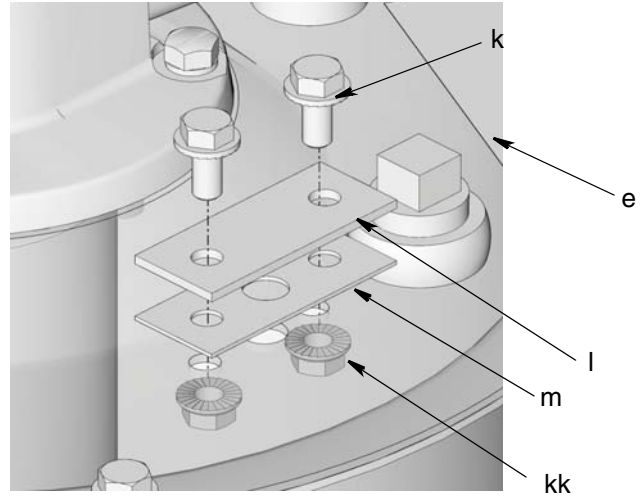

FIG. 7

4. Align gasket (7) with holes (n) in cover (e) (FIG. 8).
5. Install Auto-Fill Shut Off Valve (1) over gasket (7). Install bolts (6) through holes (n). Tighten bolts securely. See FIG. 8.

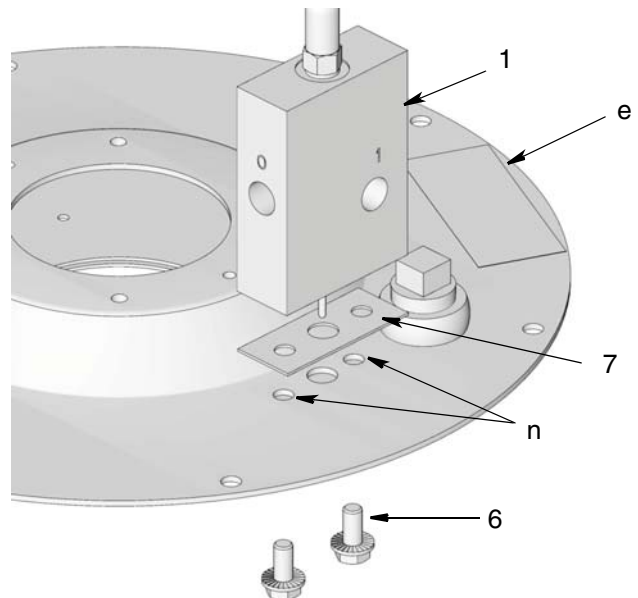

FIG. 8

6. Install cover (e) over gasket (j) on reservoir (F) (FIG. 9).

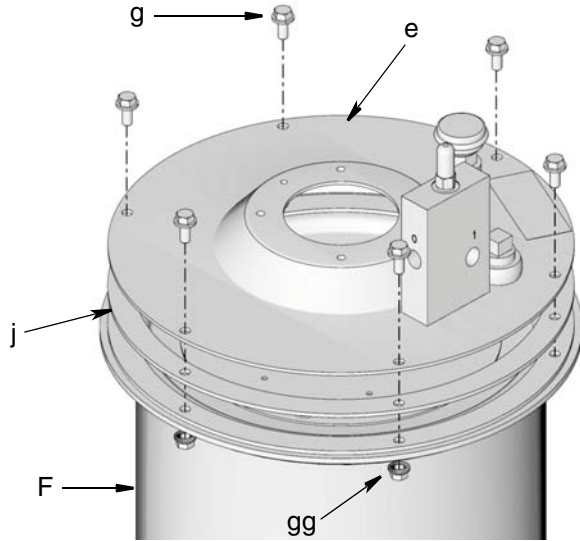

FIG. 9

7. Securely fasten cover (e) in place on top of reservoir (F) using bolts (g) and nuts (gg) removed in Step 5, page 5.

HINT: To ensure the cover is tightened correctly, turn nuts (gg) until it is snug to reservoir. Then turn it one more half turn.

NOTE: Do not over tighten cover (e) to reservoir (F). Over tightening could crush the gasket (j) between the cover and reservoir; pushing the gasket out of place and breaking the seal.

8. Install pump down-tube (p) through opening in the center of the cover (e) and hole in the center of the diaphragm (2) as shown in FIG. 10.

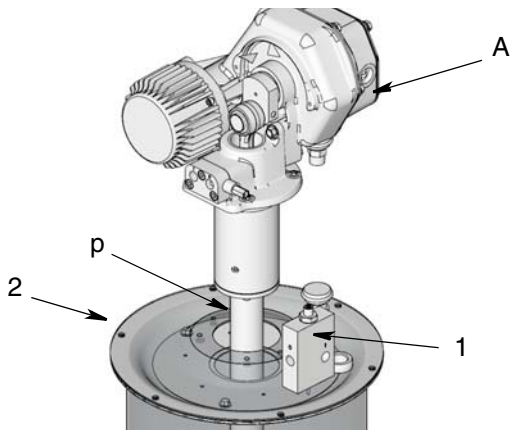

FIG. 10

NOTE: The pump down tube has two parts (FIG. 11):

- Fill tube (outer): directs grease to the bottom of the pump during the fill operation. As grease is filled into the reservoir, the diaphragm moves up. When the grease level in the reservoir has reached full, the diaphragm pushes the valve pin up, closing off fluid path, ending the fill operation.
- Pump tube (inside): when pump is operating, grease is drawn out of the bottom of the pump reservoir, through the pump tube and dispensed to the lubrication points.

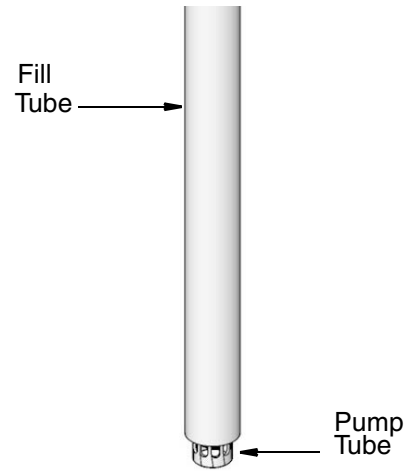

FIG. 11

NOTE: When the pump (A) is correctly installed, the breather (B) will be below the control box (r) as shown in FIG. 12.

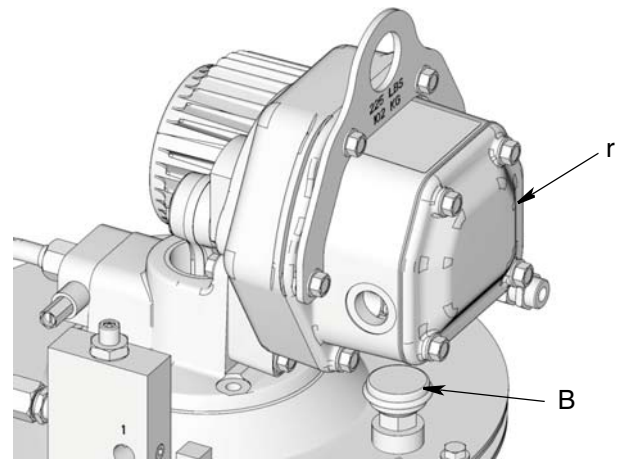

FIG. 12

9. Securely fasten pump (A) to cover (e) using screws (c) and washers (d). Use a wrench to tightened securely.

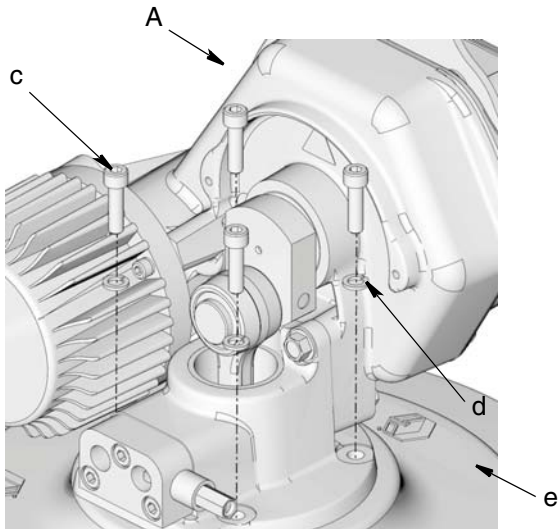

FIG. 13

10. Reinstall cover (b) using bolts (a). Use a wrench to tighten bolts securely.

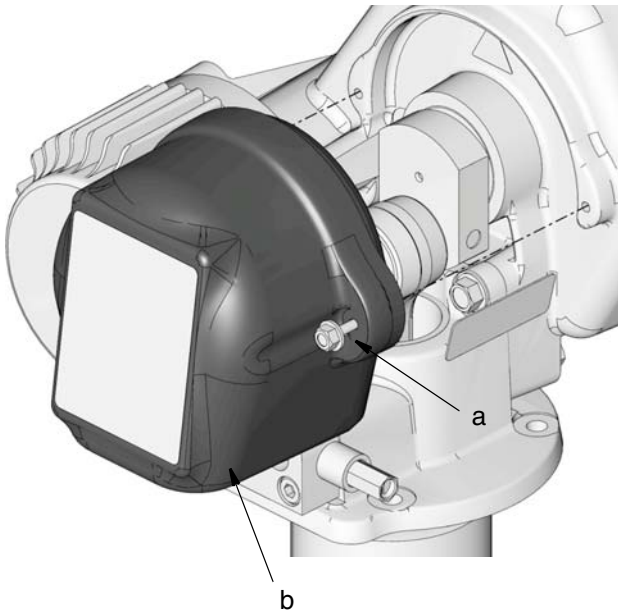

FIG. 14

11. The Auto-Fill Shutoff Kit includes two supply hoses/tubes (3 or 4 as shown on the cover.) Only one hose/tube is used. Discard the hose/tube you do not use.

- Supply tube (4) (marked with the 16V750 aluminum tag) and two connector fittings (5) are used for manifold assemblies. Supply tube (3) can be discarded. It is not used for a manifold installation.

a. Install connector fittings (5) to manifold inlet (E) and Auto-Fill Shut Off outlet (D). Wrench tighten each fitting (5) securely.

b. Install end of supply tube (4) to manifold inlet (E) first and then install the other end of the supply tube to the Auto-Fill Shut Off outlet (D) and as shown in FIG. 15.

HINT: For easier installation, loosen (but do not entirely remove) screws (G) securing manifold (F) to pump. This will allow the manifold to remain in a loosely mounted state while installing the supply tube (4). After tube has been installed securely, re-tighten manifold screws (G) to secure manifold (F) to pump.

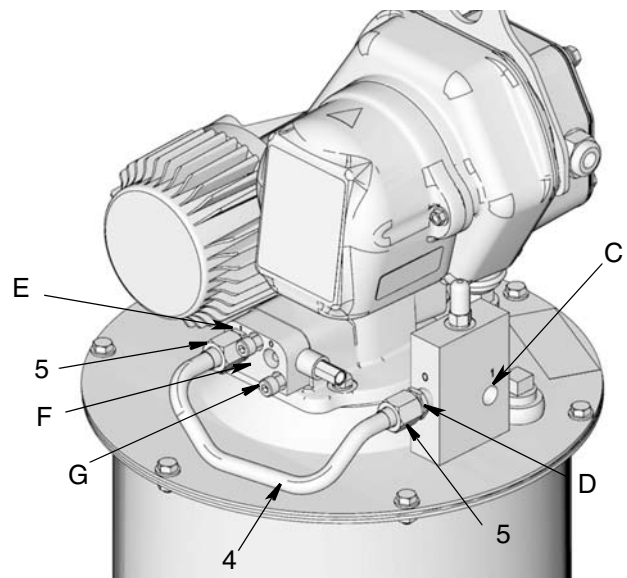

FIG. 15

- Supply tube (3) (marked with the 16X381 aluminum tag) and two connector fittings (5), are used for vent valve assemblies. Supply tube (4) can be discarded. It is not used for a vent valve installation.
- Install connector fitting (5) to Auto-Fill Shut Off outlet (D) and Vent Valve inlet (E).
 - Install end of supply tube (3) to Vent Valve inlet (E) first. Then install the other end of the supply tube to the Auto-Fill Shut Off outlet (D) as shown in FIG. 16.

HINT: For easier installation, loosen (but do not entirely remove) screws (G) securing vent valve (F) to pump. This will allow the vent valve to remain in a loosely mounted state while installing the supply tube (3). After tube has been installed securely, re-tighten vent valve screws (G) to secure vent valve (F) to pump.

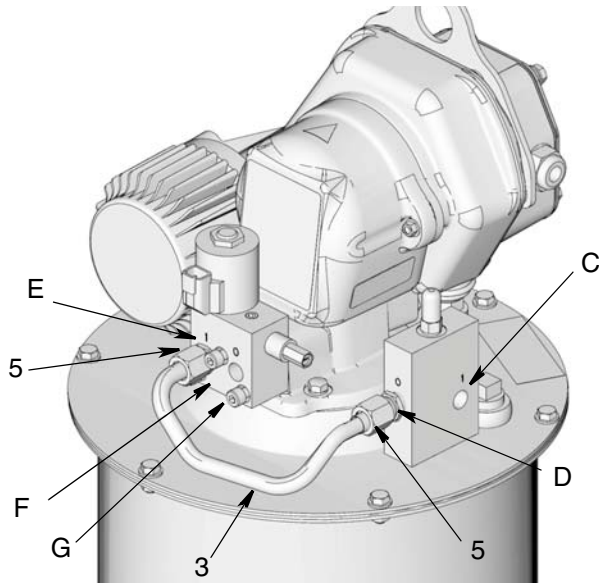

FIG. 16

- Install a (user supplied) lubricant supply hose (L) between Auto-Fill Shut Off inlet (C) (FIG. 15 or FIG. 16) and the remote filling station pump (K).



- A pressure relief valve (G) and overflow container (H) (for collecting excess fluid that drains during pressure relief) **must** be installed in an easily acces-

sible location between the remote filling station pump (K) and the Auto-Fill Shut Off (1). This pressure relief valve is used to relieve pressure in the refill line and to reset the Auto-Fill Shut Off. See Typical Installation, page 4.

NOTE:

- Operator must monitor system while filling tank to prevent accidental fluid overflow.
- A Pressure Relief Kit: 247902 is available from Graco. Contact your distributor or Graco Customer Service for additional information about this kit.
- In some setups the pressure relief valve (G) can be installed directly to the Auto-Fill Shut Off (1) as shown in FIG. 17.

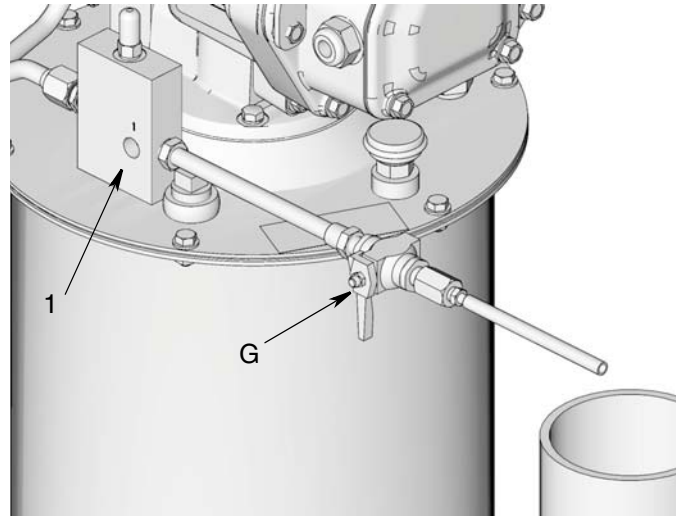
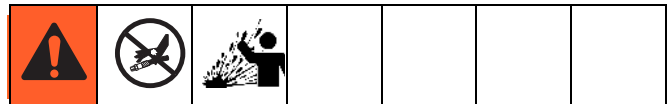

FIG. 17



COMPONENT RUPTURE HAZARD

The maximum working pressure of each component in the system may not be the same. To reduce the risk of overpressurizing any component in the system, be sure you know the maximum working pressure of each component. **Never** exceed the maximum working pressure of the lowest rated component in the system. Overpressurizing any component can result in rupture and/or property damage and serious injury.

Regulate pressure to the pump so that no fluid line, component or accessory is over pressurized.

- Turn on remote filling station pump (K) and fill reservoir (F) until the indicator pin on the Auto-Fill Valve (1) pushes up as shown in FIG. 18; pressure in the refill pump (K) builds and the pump stalls.

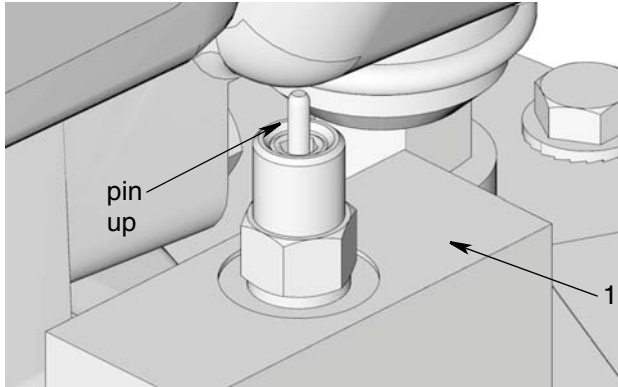







FIG. 18

- Turn off air supply to refill pump (K).
- Relieve remote filling station pump pressure using the following Remote Filling Station Pressure Relief procedure:

Remote Filling Station Pressure Relief

 The following Pressure Relief Procedure is only used with the Auto-Fill Shut Off Valve to relieve remote filling station and lubricant supply line pressure.

						
<p>This equipment stays pressurized until pressure is manually relieved. To help prevent serious injury from pressurized fluid, such as skin injection, splashing fluid and moving parts, follow the Pressure Relief Procedure when you stop dispensing and before cleaning, checking, or servicing the equipment.</p>						

- To relieve pressure between the refill pump and Auto-Fill Shut Off, open ball valve (bv) (FIG. 19). Pressure will be released and excess fluid will drain out of the drain tube (dt) and into the lubrication collection container (H).

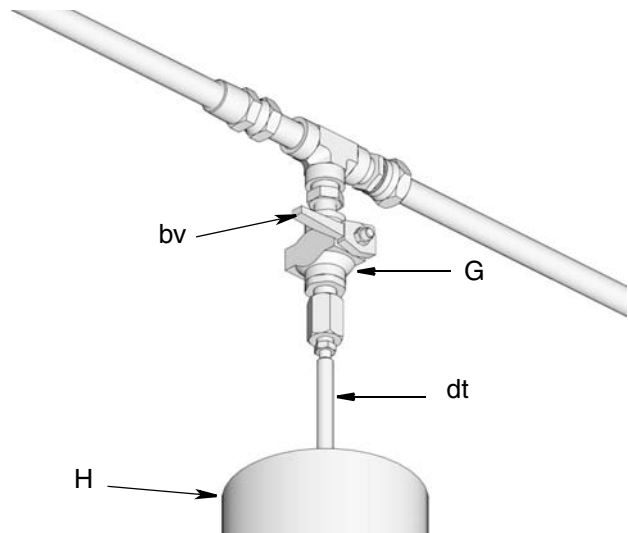

FIG. 19: In line installation shown

- Close ball valve (bv) when all pressure has been relieved.

NOTE: The pin may not drop and the Auto-Fill may not reset because the tank is full. However, when the pump begins using the grease, the pin resets. The pin must reset before the next cycle of refilling.

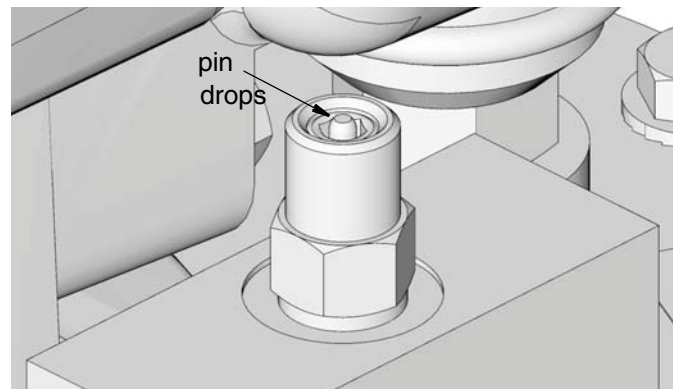

FIG. 20

- Disconnect lubrication supply hose (L) from Auto-Fill (1).
- Install plug in Auto-Fill inlet or supply hose (L) inlet to prevent contaminants from entering the pump.

Troubleshooting



Problem	Cause	Solution
Refilling pump, stalls. Pressurized tank is not refilling.	Auto-Fill Shut Off Valve is in closed condition and has not reset	1. Disconnect refilling line. 2. Relieve all line pressure using the Remote Filling Station Pressure Relief procedure provided on page 10.
		Make sure valve pin is down. See Remote Filling Station Pressure Relief procedure, Step b, page 10.

Parts

Model 77X521 (FIG. 21)

Ref	Part No.	Description	Qty
1	16V582	VALVE, auto shut off	1
2	16V748	DIAPHRAGM, assembly	1
3	16X381	TUBE, vent valve	1
4	16V750	TUBE, manifold	1
5	121311	FITTING, connector, 3/8 in. npt* x JIC	2
6	16X389	BOLT, M8 x 1.25 x 2 mm (not shown)	2
7	16V396	SEAL, auto shutoff valve	1
8	404157	CAP	1

*Prior to installation, apply thread sealant or PTFE Tape to all npt tapered pipe threads.

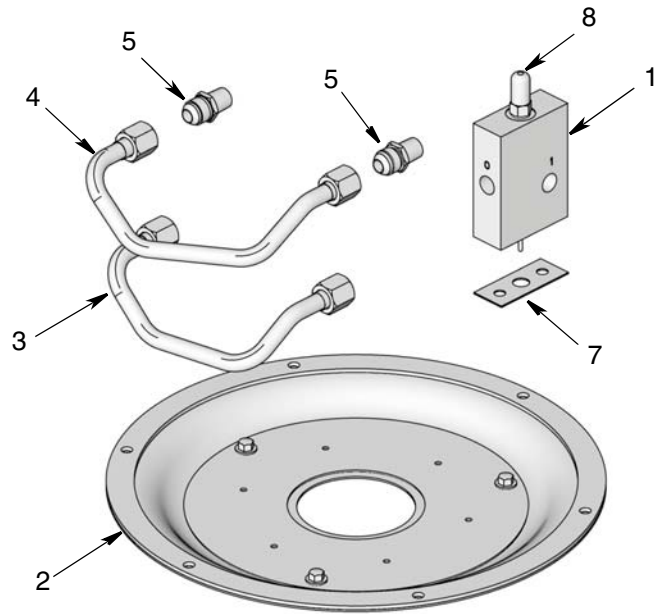

FIG. 21

Accessories

Remote Electric Signaling (FIG. 22)

Remote electric signaling can be added to the Auto-Fill Shut Off. Contact your Graco distributor or Graco Customer service for assistance when ordering these parts.

Ref	Part No.	Description
9	563272	SWITCH, cycle
	563273	SWITCH, submersible

Filter Assembly (see M, page 4)

Part No. Description
77X523 FILTER

Pressure Relief Assembly (see G, page 4)

Part No. Description
247902 PRESSURE RELIEF

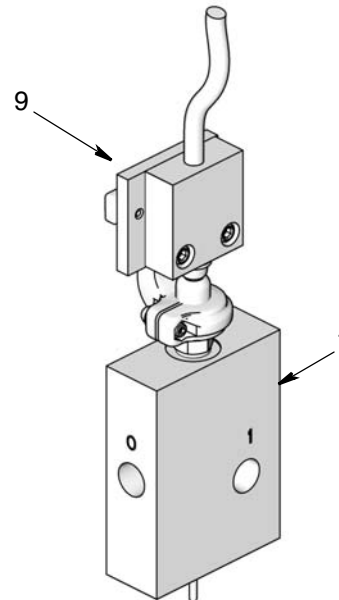
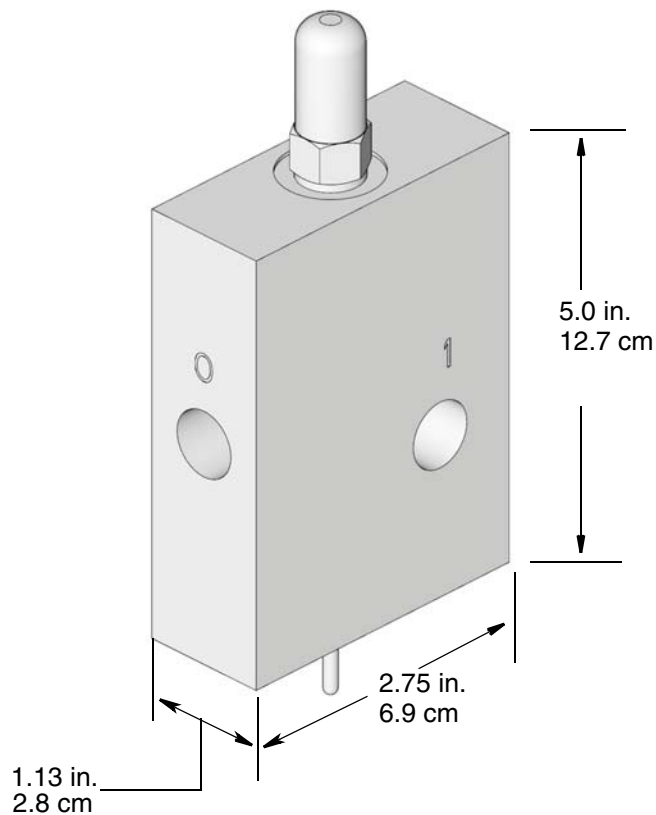

FIG. 22

Technical Data

Auto-Fill Shutoff Valve for Dyna-Star HP or HF Pump		
	US	Metric
Maximum working pressure	5000 psi	34.4 MPa, 344 bar
Inlet/Outlet Sizes		
Outlet (marked "0")	3/8 in. npt(f)	
Inlet (refill - marked "1")	3/8 in. npt(f)	
Maximum flow	2 gpm	7.6 lpm
Wetted Parts		
Valve	neoprene rubber, zinc plated parts, stainless steel, chrome plated parts, plastic acetal	
Seal	fluorocarbon	
Temperature		
Working temperature	-13° F to +122°F	-25°C to +50°C

Dimensions



Graco Information

To place an order, contact your Graco distributor or to identify the nearest distributor call,
Toll Free: 1-800-533-9655, Fax: 612-378-3590

*All written and visual data contained in this document reflects the latest product information available at the time of publication.
Graco reserves the right to make changes at any time without notice.*

For patent information, see www.graco.com/patents.

Original instructions. This manual contains English. MM 332518

Graco Headquarters: Minneapolis
International Offices: Belgium, China, Japan, Korea

GRACO INC. AND SUBSIDIARIES • P.O. BOX 1441 • MINNEAPOLIS MN 55440-1441 • USA

Copyright 2013, Graco Inc. All Graco manufacturing locations are registered to ISO 9001.

www.graco.com
February 2014