

**695 / 795 / 1095 / 1595 / Mark IV / Mark V / Mark X
Electric Airless Sprayers**

332918D

EN

For Portable Airless Spraying of Architectural Coatings and Paints.

For professional use only. Not approved for use in European explosive atmosphere locations.

3300 psi (227 bar, 22.7 MPa) Maximum Working Pressure



Important Safety Instructions

Read all warnings and instructions in this manual. Save these instructions.

Related Manuals:



332916



**309495
308491
311861
311254**



**333028
332922**

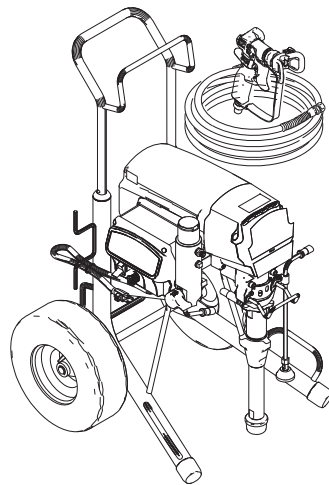

Standard Hi-Boy Series

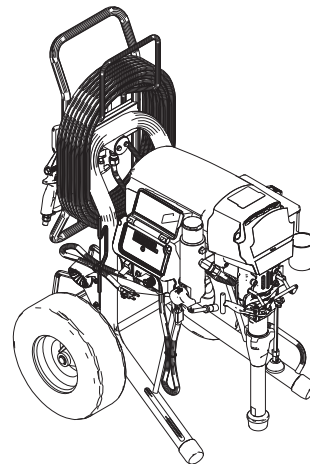

ProContractor Series

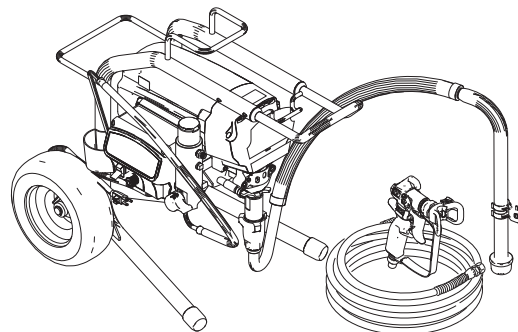

Standard Lo-Boy Series

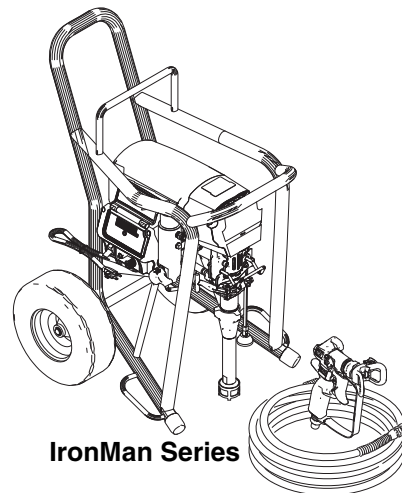

IronMan Series

ti22882a



Models

695/795/1095/1595 UltraMax II, Standard, ProContractor, IronMan Models						
Model Number	Model	Voltage	Standard Hi-Boy	Standard Lo-Boy	ProContractor	IronMan
16W892	695	120	✓			
16W893	695	120		✓		
16W894	695	120			✓	
826177	695	120	✓			
826178	695	120		✓		
826179	695	120			✓	
16W895	795	120	✓			
16W896	795	120			✓	
826180	795	120	✓			
826181	795	120			✓	
16W899	1095	120	✓			
16W900	1095	120			✓	
16W901	1095	120				✓
826182	1095	120	✓			
826183	1095	120			✓	
826184	1095	120				✓
16W902	1595	120	✓			
16W903	1595	120			✓	
16W907	1595	120				✓
16W936	1595	120	✓			
16W937	1595	120			✓	
16W938	1595	120				✓
826185	1595	120	✓			
826186	1595	120			✓	
826187	1595	120				✓
826188	1595	120	✓			
826189	1595	120			✓	
826190	1595	120				✓

Mark IV / Mark V / Mark X Standard, ProContractor, IronMan Models												
Model Number	Model	Voltage	Standard Series	Pro Contractor Series	IronMan Series	Flex Plus Gun	Blue Texture Gun	HD Inline Texture Gun	3/8 in. x 50ft + 1/4 in. x 3 ft whip (9.5mm x 15m + 6.4mm x 0.9m whip)	3/8 in. x 100 ft + 1/4 in. x 3 ft whip (9.5mm x 30m + 6.4mm x 0.9m whip)	1/2 in. x 50 ft + 3/8 in. x 12 ft whip (12.7mm x 15m + 9.5mm x 3.7m whip)	1/2 in. x 100 ft + 3/8 in. x 12 ft whip (12.7mm x 30m + 9.5mm x 3.7m whip)
16W897	Mark IV	120	✓			✓			✓			
16W898	Mark IV	120		✓		✓				✓		
16W905	Mark V	120	✓				✓		✓			
16W906	Mark V	120		✓			✓			✓		
16W939	Mark V	120	✓				✓		✓			
16W940	Mark V	120		✓			✓			✓		
16X947	Mark V	120			✓		✓			✓		
16W908	Mark X	230	✓					✓			✓	
16X099	Mark X	230		✓				✓				✓

Table of Contents

Models	2	Mark X ProContractor	16
695 Lo-Boy Standard	4	Mark X ProContractor	17
695 Lo-Boy Standard Parts List	5	1095/1595/Mark V IronMan	18
695/795/Mark IV Hi-Boy Standard	6	1095/1595/Mark V IronMan	19
695/795/Mark IV Hi-Boy Standard Parts List	7	Hose Reel and Gun	20
1095/1595/Mark V Hi-Boy Standard	8	Parts List	20
1095/1595/Mark V Hi-Boy Standard	9	Control Box	21
Mark X Standard	10	Parts List	21
Mark X Standard Parts List	11	Filter	22
695/795/MARK IV ProContractor	12	Parts List	22
695/795/MARK IV ProContractor Parts List	13	Notes	23
1095/1595/MARK V ProContractor	14	Graco Standard Warranty	24
1095/1595/MARK V ProContractor Parts List	15		

695 Lo-Boy Standard

Ref.	Torque
1	40-45 in-lb (4.5 - 5.0 N•m)
2	9-11 in-lb (1.0 - 1.2 N•m)
3	200-230 in-lb (22.6 - 25.9 N•m)
4	190-210 in-lb (21.4 - 23.7 N•m)
5	22-28 in-lb (2.4 - 3.1 N•m)
6	25-30 ft-lb (33.8 - 40.6 N•m)
7	70-80 ft-lb (94.9 - 108.4 N•m)
8	130-150 in-lb (14.6 - 16.9 N•m)

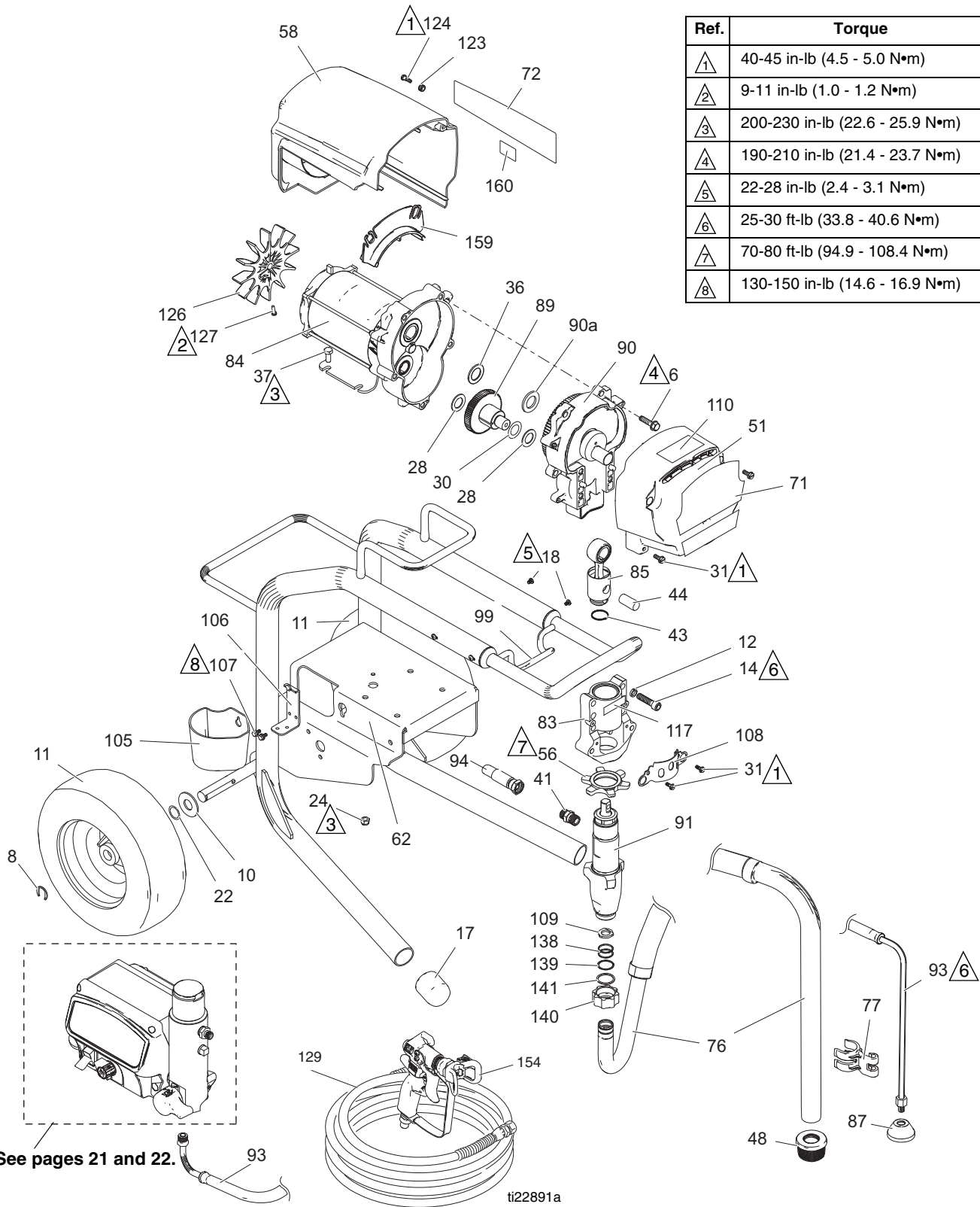

695 Lo-Boy Standard Parts List

Ref.	Part	Description	Qty.	Ref.	Part	Description	Qty.
6	15C753	SCREW, mach, torx, hex	5	85	241008	ROD, connecting; <i>includes 43</i>	1
8	15E891	CLIP, retaining	2	87	241920	DEFLECTOR, threaded	1
10	156306	WASHER, flat	2	89	287289	GEAR, combination; <i>includes 28, 30</i>	1
11*	119420	WHEEL, pneumatic	2	90	287283	HOUSING, drive, M1; <i>includes 6, 36, 90a</i>	1
12	106115	WASH, lock, spring	4	90a	107089	WASHER, race, thrust	1
14	110141	SCREW, cap, socket hd	4	91	16Y598	PUMP, displacement 695/795	1
17	15C871	CAP, leg	2	93	248217	HOSE, drain; <i>includes 87</i>	1
18	109032	SCREW, mach, pnh	4	94	16X904	HOSE, coupled, 1/4 x 15.75	1
22	116038	WASHER, wave spring	2	99	24A249	HANDLE, cart	1
24	111040	NUT, hex, flanged	4	105	276975	CUP, drain	1
28	114672	WASHER, thrust	2	106	15F952	BRACKET, drain cup	1
30	114699	WASHER, thrust	1	107	114423	SCREW, mach, hex hd	2
31	118444	SCREW, machine, hex washer hd	6	108	16X770	SHIELD, pump rod	1
36	116191	WASHER, thrust	1	109	115099	WASHER, garden hose	1
37	100057	SCREW, cap, hex hd	4	110	16X983	LABEL, Standard Series	1
41	196178	FITTING	1	117	187437	LABEL, torque	1
43	176817	SPRING, retaining	1	123	276980	GROMMET, cover	2
44	176818	PIN, str, hdls	1	124	119250	SCREW, shoulder, hex washer	2
48	189920	STRAINER, (1-11 1/2 NPSM)	1	126	15D088	FAN, motor	1
51	24V023	COVER, drive, plastic, painted; <i>includes 31</i>	1	127	115477	SCREW, mach, torx, pan hd	1
56	192723	NUT, retaining	1	128▲	222385	TAG, WARNING (not shown)	1
58	287281	695 SHIELD, motor, painted; <i>includes 123, 124</i>	1	129	240794	HOSE, cpld, 1/4 in. x 50 ft	1
62	24P665	FRAME, cart	1		826079	Ultra	
71		LABEL	1		117559	Ultimate	
	16X364	Ultra 695		138	118505	O-RING	2
	16X786	Ultimate 695		139	118505	RING, retaining, external	1
72		LABEL	1	140	15C980	NUT, jam	1
	16X365	Ultra 695		141	15C981	WASHER, suction swivel	1
	16X787	Ultimate 695		154	288420	GUN, contractor	1
76	248216	HOSE, suction; <i>includes 109, 138, 139, 140, 141</i>	1			Manual 311861	
77	15D000	CLIP, drain line	1	159	278075	BAFFLE	1
83	24V026	HOUSING, bearing; <i>includes 12, 14, 31, 108, 117</i>	1	160	15Y118	LABEL, Made in USA	1
84	257185	MOTOR, electric; <i>includes 126, 127</i>	1				

* 253132 KIT, repair, tube, 11 in.

▲Extra Danger & Warning tags & labels available free.

695/795/Mark IV Hi-Boy Standard

Ref.	Torque
△1	40-45 in-lb (4.5 - 5.0 N•m)
△2	9-11 in-lb (1.0 - 1.2 N•m)
△3	200-230 in-lb (22.6 - 25.9 N•m)
△4	190-210 in-lb (21.4 - 23.7 N•m)
△5	22-28 in-lb (2.4 - 3.1 N•m)
△6	25-30 ft-lb (33.8 - 40.6 N•m)
△7	70-80 ft-lb (94.9 - 108.4 N•m)
△8	130-150 in-lb (14.6 - 16.9 N•m)

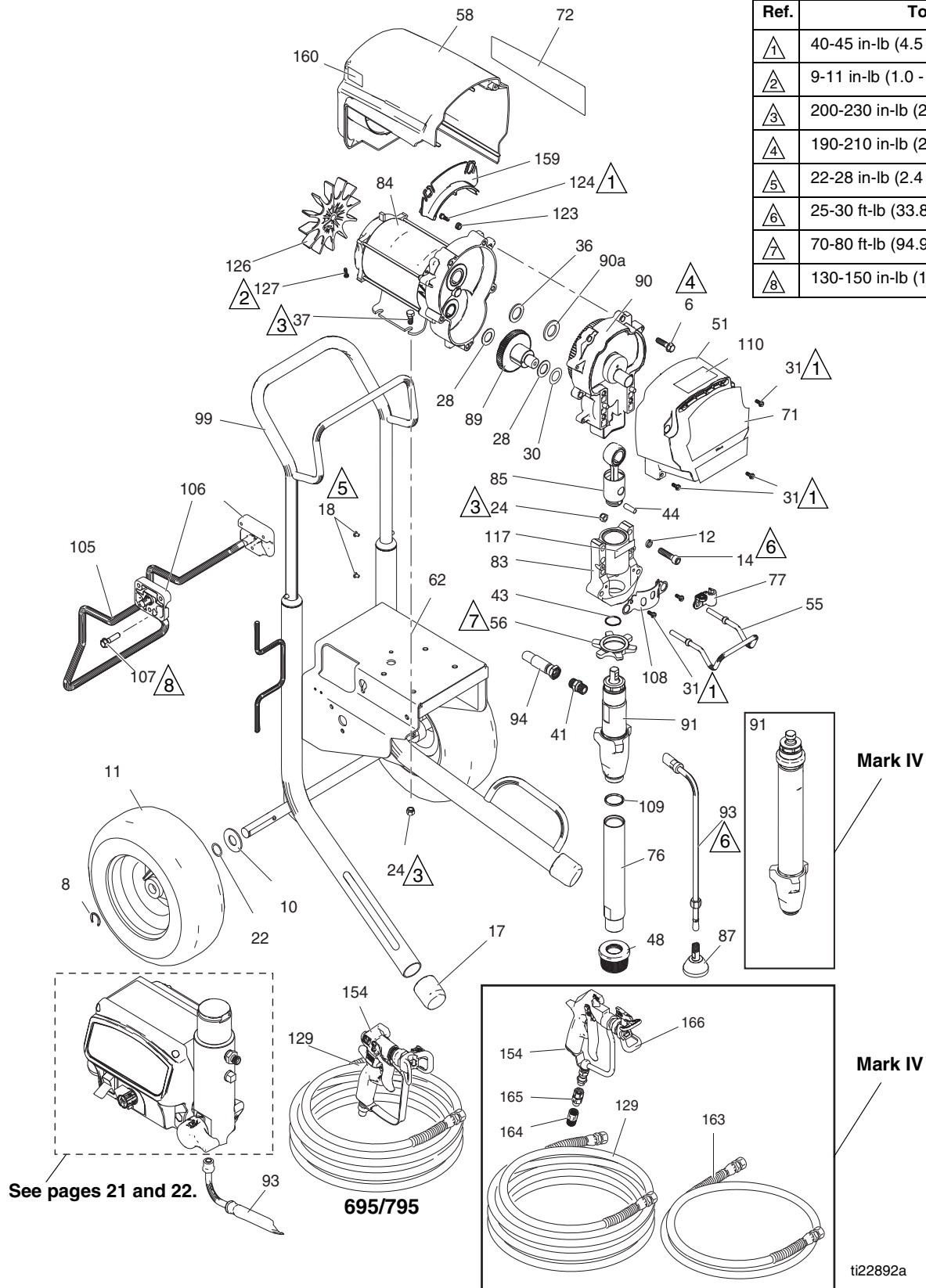

695/795/Mark IV Hi-Boy Standard Parts List

Ref.	Part	Description	Qty.	Ref.	Part	Description	Qty.
6	15C753	SCREW, mach, torx, hex	5	89	287289	GEAR, combination; <i>includes 28, 30</i>	1
8	15E891	CLIP, retaining	2				
10	156306	WASHER, flat	2	90		HOUSING, drive, M1; <i>includes 6, 36, 90a</i>	1
11*	119420	WHEEL, pneumatic	2				
12	106115	WASH, lock, spring	4		287283	695	
14	110141	SCREW, cap, socket hd	4		287284	795/Mark IV	
17	15C871	CAP, leg	2	90a	107089	WASHER, race, thrust	1
18	109032	SCREW, mach, prh	4	91		PUMP, displacement; <i>includes 41, 109</i>	1
22	116038	WASHER, wave spring	2				
24	111040	NUT, hex, flanged	6		16Y598	695/795	
28	114672	WASHER, thrust	2		16X428	Mark IV	
30	114699	WASHER, thrust	1	93	244240	HOSE, coupled; <i>includes 87</i>	1
31	118444	SCREW, machine, hex washer hd	6	94	16X904	HOSE, coupled, 1/4 x 15.75	1
36	116191	WASHER, thrust	1	99	287489	HANDLE, cart	1
37	100057	SCREW, cap, hex hd	4	105	16X695	HANGER, stand, cart	1
41	196178	FITTING	1	106	15C982	CAM, cart	2
43	176817	SPRING, retaining	1	107	114531	SCREW, mach, hex washer	4
44	176818	PIN, str, hdls	1	108	16X770	SHIELD, pump rod	1
48	189920	STRAINER, (1-11 1/2 NPSM)	1	109	118494	PACKING, o-ring	1
51	24V023	COVER, drive, plastic, painted; <i>includes 31</i>	1	110	16X983	LABEL, Standard Series	1
				117	187437	LABEL, torque	1
55	16C457	HANGER, pail	1	123	276980	GROMMET, cover	2
56	192723	NUT, retaining	1	124	119250	SCREW, shoulder, hex, washer	2
58		SHIELD, motor, painted; <i>includes 123, 124</i>	1	126	15D088	FAN, motor	1
				127	115477	SCREW, mach, torx, pan, hd	1
	287281	695		128▲	222385	TAG, WARNING (not shown)	1
	287282	795/Mark IV		129		HOSE, cpld	1
62	24P666	FRAME, cart	1		240794	695/795 Ultra	
71		LABEL	1		826079	695/795 Ultimate	
	16X364	Ultra 695			240797	Mark IV	
	16X367	Ultra 795		154		GUN, contractor	1
	16X786	Ultimate 695			288420	695/795	
	16X788	Ultimate 795			246468	Mark IV	
	16X357	TexSpray Mark IV		159	278075	BAFFLE	1
72		LABEL	1	160	15Y118	LABEL, Made in USA	1
	16X365	Ultra 695		163	241735	HOSE, coupled, 1/4 in. x 3 ft	1
	16X366	Ultra 795		164	159841	BUSHING, 3/8 in. x 1/4 in.	1
	16X787	Ultimate 695		165	189018	SWIVEL, assembly	1
	16X789	Ultimate 795		166	246215	GUARD, RAC X	1
	17A135	TexSpray Mark IV					
76	248214	TUBE, intake; <i>includes 109</i>	1				
77	278204	CLIP, spring	1				
83	24V026	HOUSING, bearing; <i>includes 12, 14, 24, 31, 55, 77, 108, 117</i>	1				
84		MOTOR, electric; <i>includes 106, 127</i>	1				
	257185	695					
	257186	795/Mark IV					
85	241008	ROD, connecting; <i>includes 43</i>	1				
87	241920	DEFLECTOR, threaded	1				

▲ Extra Danger and Warning tags and labels available free.

* 253132 KIT, repair, tube

1095/1595/Mark V Hi-Boy Standard

Ref.	Torque
①	40-45 in-lb (4.5 - 5.0 N•m)
②	9-11 in-lb (1.0 - 1.2 N•m)
③	200-230 in-lb (22.6 - 25.9 N•m)
④	190-210 in-lb (21.4 - 23.7 N•m)
⑤	22-28 in-lb (2.4 - 3.1 N•m)
⑥	25-30 ft-lb (33.8 - 40.6 N•m)
⑦	70-80 ft-lb (94.9 - 108.4 N•m)
⑧	130-150 in-lb (14.6 - 16.9 N•m)

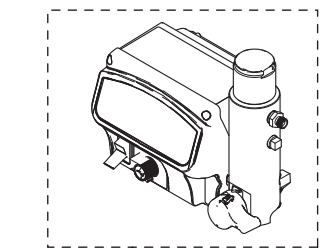
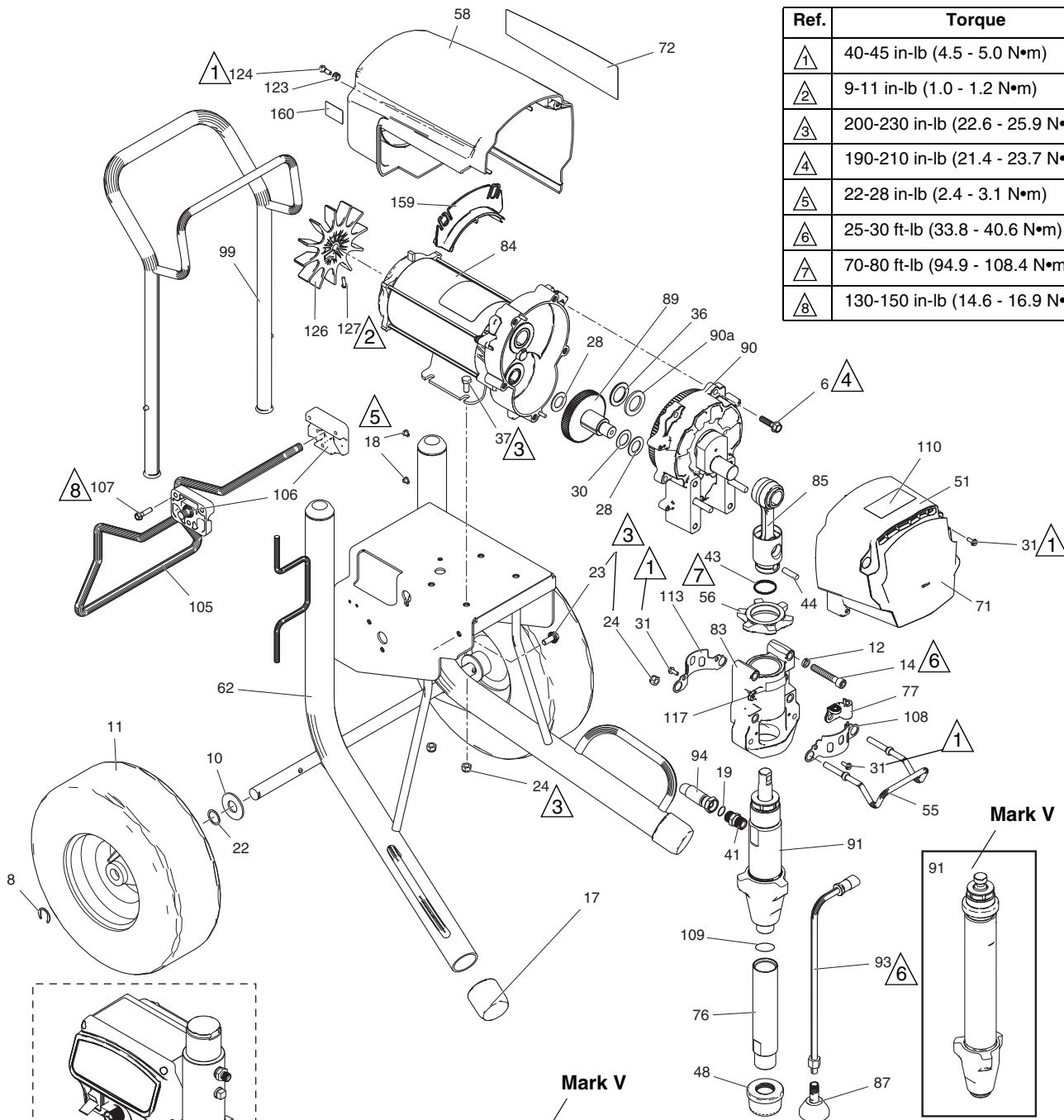

See pages 21 and 22.

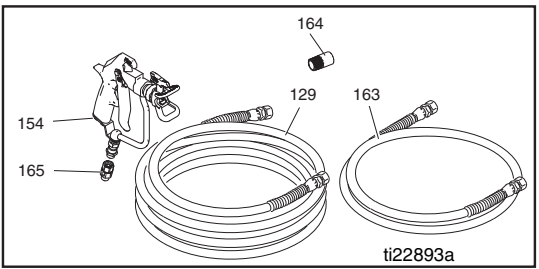
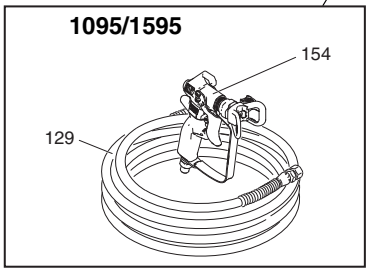

1095/1595/Mark V Hi-Boy Standard

Ref.	Part	Description	Qty.	Ref.	Part	Description	Qty.
6	15C753	SCREW, mach, torx, hex	5	85	24V021	ROD, connecting; <i>includes 43, 44</i>	1
8	15E891	CLIP, retaining	2	87	241920	DEFLECTOR, threaded	1
10	156306	WASHER, flat	2	89	287290	GEAR, combination;	1
11*	119509	WHEEL, pneumatic	2			<i>includes 28, 30</i>	
12	106115	WASH, lock, spring	4	90		HOUSING, drive, M1;	1
14	114666	SCREW, cap, socket hd	4			<i>includes 6, 36, 90a</i>	
17	276974	CAP, leg	2		287294	1095	
18	108795	SCREW, mach, pnh	4		287295	1595/Mark V	
19	102982	PACKING, o-ring (Mark V)	1	90a	194173	WASHER, race, thrust	1
22	116038	WASHER, wave spring	2	91		PUMP, displacement;	1
23	117791	SCREW, cap, flng hd	2			<i>includes 41, 76, 109</i>	
24	111040	NUT, hex, flanged	6		16Y706	1095/1595	
28	114672	WASHER, thrust	2		16X429	Mark V	
30	114699	WASHER, thrust	1	93	244240	HOSE, drain; <i>includes 87</i>	1
31	118444	SCREW, machine, hex washer hd	8	94		HOSE, coupled	1
36	116192	WASHER, thrust	1		16X904	1095/1595	
37	100057	SCREW, cap, hex hd	4		24V029	Mark V; <i>includes 19</i>	
41		FITTING, pump, quick disc	1	99	24A250	HANDLE, cart	1
	196178	1095/1595		105	16X696	HANGER, stand, cart	1
	16X834	Mark V		106	15C982	CAM, cart	2
43	119778	SPRING, retaining	1	107	114531	SCREW, mach, hex washer	4
44	183210	PIN, pump	1	108	16X770	PUMP, shield rod	1
48	189920	STRAINER, (1-11 1/2 NPSM)	1	109	118494	PACKING, o-ring	1
51	24V024	COVER, drive, plastic, painted;	1	110	16X983	LABEL, Standard Series	1
		<i>includes 31</i>		113	15C762	SHIELD, pump rod	1
55	16C457	HANGER, pail	1	117	187437	LABEL, torque	1
56	193031	NUT, retaining	1	123	276980	GROMMET, cover	2
58	287282	SHIELD, motor, painted;	1	124	119250	SCREW, shoulder, hex, washer	3
		<i>includes 123, 124</i>		126	15D088	FAN, motor	1
62	24P667	FRAME, cart 1095/1595	1	127	115477	SCREW, mach, torx, pan, hd	1
71		LABEL, UltraMax	1	128▲	222385	TAG, WARNING (not shown)	1
	16X368	Ultra 1095		129		HOSE, cpld	1
	16X371	Ultra 1595			240794	Ultra 1095/1595	
	16X790	Ultimate 1095			826079	Ultimate 1095/1595	
	16X792	Ultimate 1595			240797	Mark V	
	16X360	TexSpray Mark V		154		GUN, contractor 1095/1595	1
72		LABEL, UltraMax II 1095/1595	1		288420	1095/1595	
	16X369	Ultra 1095			241705	Mark V	
	16X370	Ultra 1595		159	278075	BAFFLE	1
	16X791	Ultimate 1095		160	15Y118	LABEL, Made in USA	1
	16X793	Ultimate 1595		163	241735	HOSE, cpld, 1/4 in. x 3 ft	1
	16X361	TexSpray Mark V		164	159841	BUSHING, 3/8 in. x 1/4 in.	1
76	248215	TUBE, intake; <i>includes 109</i>	1	165	189018	SWIVEL, assembly	1
77	278204	CLIP, drain line	1				
83	24V027	HOUSING, bearing; <i>includes 12,</i>	1				
		<i>14, 24, 31, 55, 77, 108, 113, 117</i>					
84		MOTOR, electric;	1				
		<i>includes 126, 127</i>					
	257187	1095					
	257188	1595					

▲ *Extra Danger and Warning tags and labels available free.*
 * *253131 KIT, repair, tube*

Mark X Standard

Ref.	Torque
▲1	40-45 in-lb (4.5 - 5.0 N•m)
▲2	55-60 in-lb (6.2 - 6.7 N•m)
▲3	200-230 in-lb (22.6 - 25.9 N•m)
▲4	190-210 in-lb (21.4 - 23.7 N•m)
▲5	22-28 in-lb (2.4 - 3.1 N•m)
▲6	25-30 ft-lb (33.8 - 40.6 N•m)
▲7	70-80 ft-lb (94.9 - 108.4 N•m)
▲8	130-150 in-lb (14.6 - 16.9 N•m)

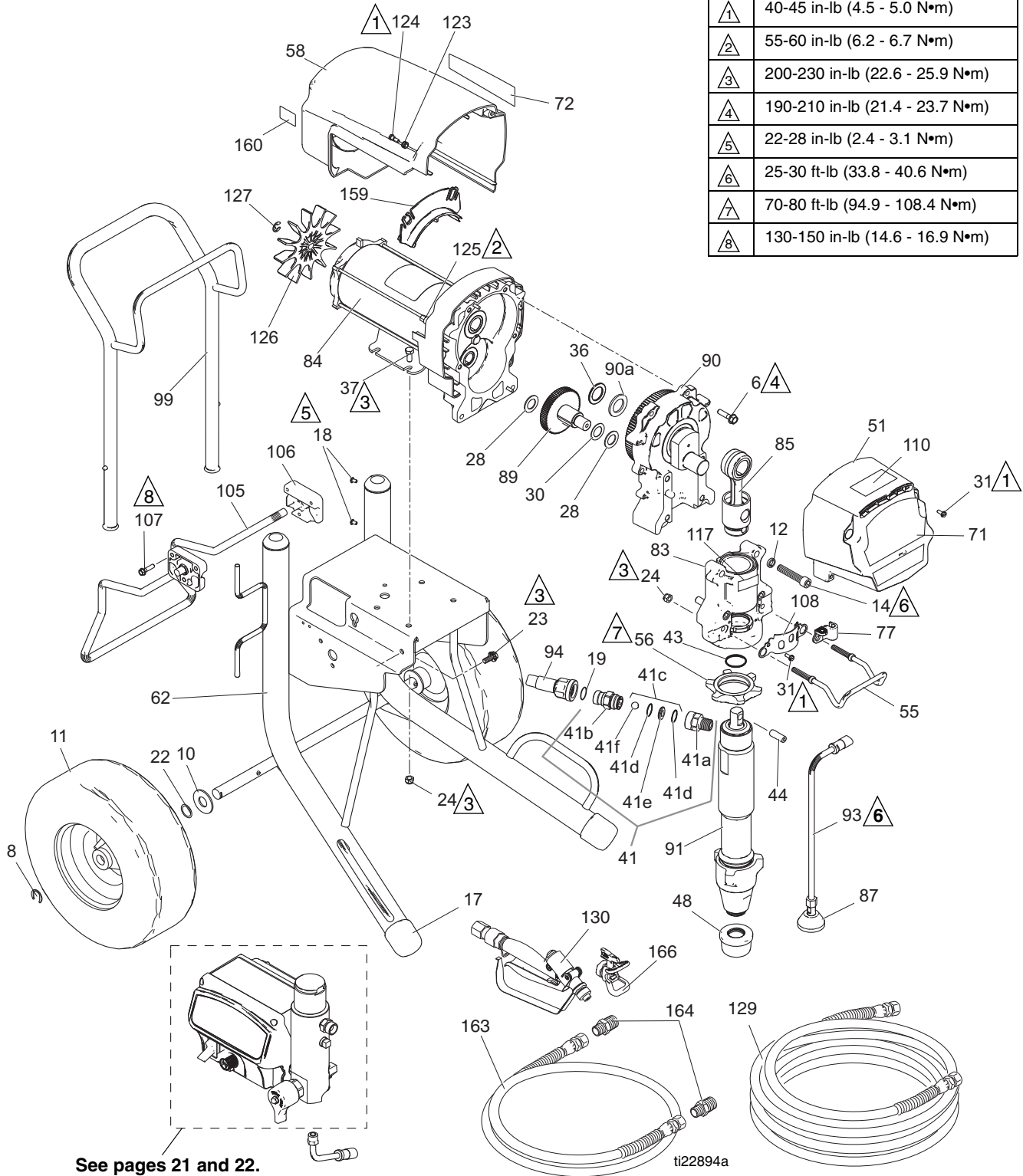

Mark X Standard Parts List

Ref.	Part	Description	Qty.	Ref.	Part	Description	Qty.
6	15C753	SCREW, mach, torx, hex	6	83	24V028	HOUSING, bearing; <i>includes 12, 14, 24, 31, 55, 77, 108, 117</i>	1
8	15E891	CLIP, retaining	2	84	258909	MOTOR, electric; <i>includes 125, 126, 127</i>	1
10	156306	WASHER, flat	2	85	24V022	ROD, connecting; <i>includes 43, 44</i>	1
11*	119509	WHEEL, pneumatic	2	87	241920	DEFLECTOR, threaded	1
12	112600	WASH, lock, spring	4	89	288035	GEAR, combination; <i>includes 28, 30</i>	1
14	112599	SCREW, cap, socket hd	4	90	287990	HOUSING, drive; <i>includes 6, 36, 90a</i>	1
17	276974	CAP, leg	2	90a	194173	WASHER, race, thrust	1
18	108795	SCREW, mach, pnh	4	91	16X425	PUMP, displacement	1
19	102982	O-RING	1	93	244240	HOSE, drain; <i>includes 87</i>	1
22	116038	WASHER, wave spring	2	94	24V029	HOSE, coupled; <i>includes 19</i>	1
23	117791	SCREW, cap, flng hd	2	99	24A250	HANDLE, cart	1
24	111040	NUT, lock	6	105	16X696	HANGER, stand, cart	1
28	114672	WASHER, thrust	2	106	15C982	CAM, cart	2
30	114699	WASHER, thrust	1	107	114531	SCREW, mach, hex washer	4
31	118444	SCREW, machine, hex washer hd	6	108	16X770	SHIELD, pump rod	1
36	116192	WASHER, thrust	1	110	16X983	LABEL, Standard series	1
37	100057	SCREW, cap, hex hd	4	117	187437	LABEL, torque	1
41	24U755	VALVE, check, quick disc	1	123	276980	GROMMET, cover	2
41a	16N461	HOUSING, seat, check valve	1	124	119250	SCREW, shoulder, hex, washer	3
41b	16X837	HOUSING, ball, check valve	1	125	15G845	SPACER, standoff	2
41c	24M725	KIT, repair, check valve; <i>includes 41d, 41e, 41f</i>	1	126	15V577	FAN, motor	1
41d		O-RING	2	127	122347	SCREW, mach, torx, pan, hd	1
41e		SEAT	1	128▲	222385	TAG, WARNING (not shown)	1
41f		BALL	1	129	278499	HOSE, cpld, 1/2 in. x 50 ft	1
43	119677	SPRING, retaining	1	130	245820	GUN, spray, texture	1
44	197443	PIN, pump	1	159	278075	BAFFLE	1
48	189920	STRAINER, (1-11 1/2 NPSM)	1	160	15Y118	LABEL, Made in USA	1
51	24V025	COVER, drive, plastic, painted; <i>includes 31</i>	1	163	191239	HOSE, cpld, 3/8 in. x 3 ft	1
55	16C457	HANGER, pail	1	164	159239	ADAPTER	2
56	193394	NUT, retaining	1	166	246215	GUARD, RAC X	1
58	287282	SHIELD, motor, painted; <i>includes 123, 124</i>	1				
62	24P667	FRAME, cart	1				
71	16X362	LABEL, Mark X	1				
72	16X363	LABEL, Mark X	1				
77	278204	CLIP, drain line	1				

▲ Extra Danger and Warning tags and labels available free.

* 253131 KIT, repair, tube

695/795/MARK IV ProContractor Parts List

Ref.	Part	Description	Qty.	Ref.	Part	Description	Qty.
5	16C975	PLATE, pivot	1	76	248214	TUBE, intake; <i>includes 109</i>	1
6	15C753	SCREW, mach, hex wash hd	5	77	16X203	CLIP, drain line	1
7	105510	WASHER, lock, spring	2	83	24V087	HOUSING, bearing; <i>includes 7, 12, 14, 15, 24, 31, 55, 56, 77, 108, 117</i>	1
8	15E891	CLIP, retaining	2				
10	156306	WASHER, flat	2	84		MOTOR, electric	1
11	119420	WHEEL, pneumatic	2		257185	695 Models	
12	106115	WASHER, lock (hi-collar)	4		257186	795 Models	
14	110141	SCREW, cap, sch	4	85	24V084	ROD, connecting	1
15	101550	SCREW, cap, sch	2	87	241920	DEFLECTOR, threaded	1
16	121311	FITTING, connector	1	89	287289	GEAR, combination;	1
17	276974	CAP, leg	2			<i>includes 28, 30</i>	
18	260212	SCREW, hex washer hd	2	90		HOUSING, drive, M1;	1
19		PACKING, o-ring	1			<i>includes 6, 36, 90a</i>	
	107505	695/795			24V032	695 Models	
	102982	Mark IV			24V033	795/Mark IV	
22	116038	WASHER, wave spring	2	90a	107089	WASHER, race, thrust	1
23	117791	SCREW, cap tri lobe	2	91	16X414	PUMP, displacement, 695/795;	1
24	111040	NUT, lock, nylon, thin pattern	6			<i>includes 41, 109</i>	
25	16X833	FITTING, QD, 695/795	1		16X418	PUMP, displacement, Mark IV	
27	120583	NUT, hand, 695/795	1	93	244240	HOSE, drain, ultra hi-boy;	1
28	114672	WASHER, thrust	2			<i>includes 87</i>	
29	278083	GUIDE, hose, platinum	1	94		HOSE, coupled	1
30	114699	WASHER, thrust	1		16X904	695/795	
31	118444	SCREW, mach, slot hex wash hd	5		24V029	Mark IV; <i>includes 19</i>	
35	117633	SCREW, slot hex wash hd	2	103	287253	TOOL BOX; <i>includes 104</i>	1
36	116191	WASHER, thrust, 1095/795	1	104	118852	SCREW, thd forming, hex	3
37	100057	SCREW, cap, hex hd	4			washer hd	
39	24V095	TUBE, formed, ultra, platinum	1	105	16X697	HANGER, stand	1
41		FITTING	1	106	15C982	CAM, cart	2
	16Y579	695/795		107	114531	SCREW, mach, hex washer hd	4
	16X834	Mark IV		108	16X228	PLATE, front, 3900 PC11	1
48	189920	STRAINER, (1-11 1/2 npsm)	1	109	118494	PACKING, o-ring	1
51	24V023	COVER, drive, plastic, painted;	1	110	16X981	LABEL, ProContractor Series	1
		<i>includes 31</i>		111	187437	LABEL, torque	1
55	16C457	HANGER, pail	1	123	276980	GROMMET, cover	2
56	16X322	CLAMP, pump	1	124	119250	SCREW, shoulder	2
58		SHIELD, motor, painted;	1	126	15D088	FAN, motor	1
		<i>includes 123, 124</i>		127	115477	SCREW, mach, torx pan hd	1
	287281	695 Models		128▲	222385	TAG, warning (not shown)	1
	287282	795/Mark IV Models		159	278075	BRACKET, wire	1
62	24P668	FRAME, platinum, 695/795	1	160	15Y118	LABEL, Made in the USA	1
71		LABEL, brand, front	1				
	16X364	695 Ultra					
	16X367	795 Ultra					
	16X786	695 Ultimate					
	16X788	795 Ultimate					
	16X357	Mark IV TexSpray					
72		LABEL, brand, side	1				
	16X365	695 Ultra					
	16X366	795 Ultra					
	17A135	Mark IV TexSpray					
	16X787	695 Ultimate					
	16X789	795 Ultimate					

▲ Extra Danger and Warning tags and labels available free.

1095/1595/MARK V ProContractor

Ref.	Torque
1	40-45 in-lb (4.5 - 5.0 N•m)
2	9-11 in-lb (1.0 - 1.2 N•m)
3	200-230 in-lb (22.6 - 25.9 N•m)
4	190-210 in-lb (21.4 - 23.7 N•m)
5	120-130 in-lb (13.5 - 14.6 N•m)
6	25-30 ft-lb (33.8 - 40.6 N•m)
7	38-42 ft-lb (51.5 - 56.9 N•m)
8	130-150 in-lb (14.6 - 16.9 N•m)
9	30-35 in-lb (3.4 - 4.0 N•m)
10	90-110 in-lb (10.1 - 12.4 N•m)

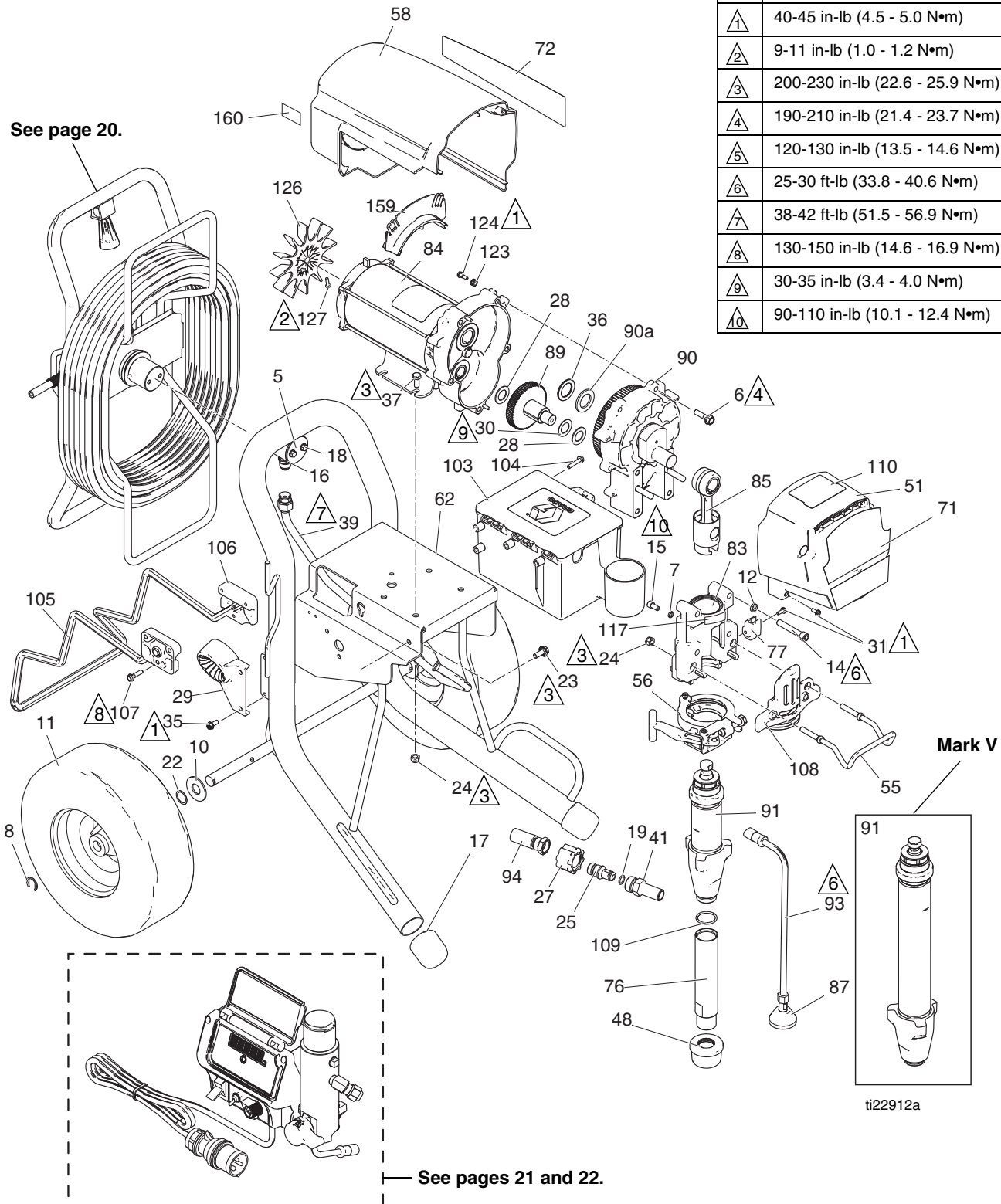

1095/1595/MARK V ProContractor Parts List

Ref.	Part	Description	Qty.	Ref.	Part	Description	Qty.
5	16C975	PLATE, pivot	1		16X793	1595 Ultimate	
6	15C753	SCREW, mach, hex wash hd	5	76	248215	TUBE, intake; <i>includes 109</i>	1
7	105510	WASHER, lock	2	77	16X203	CLIP, drain line	1
8	15E891	CLIP, retaining	2	83	24V088	HOUSING, bearing; <i>includes 7, 12, 14, 15, 24, 31, 55, 56, 77, 108, 117</i>	1
10	156306	WASHER, flat	2				
11	119509	WHEEL, pneumatic	2	84		MOTOR, electric; <i>includes 126, 127</i>	1
12	106115	WASHER, lock (hi-collar)	4		257187	1095 Models	
14	114666	SCREW, cap, socket head	4		257188	1595/Mark V Models	
15	101550	SCREW, cap, sch	2	85	24V085	ROD, connecting	1
16	121311	FITTING, connector	1	87	241920	DEFLECTOR, threaded	1
17	276974	CAP, leg	2	89	287290	GEAR, combination;	1
18	260212	SCREW, hex washer hd	2			<i>includes 28, 30</i>	
19		PACKING, o-ring	1	90		HOUSING, drive, M1;	1
	107505	1095/1595				<i>includes 6, 36, 90a</i>	
	102982	Mark V			287294	1095 Models	
22	116038	WASHER, wave spring	2		287295	1595/Mark V Models	
23	117791	SCREW, cap tri lobe	2	90a	194173	WASHER, race, thrust	1
24	111040	NUT, lock, insert	6	91		PUMP, displacement;	1
25	16X833	FITTING, quick disconnect, (1095/1595 only)	1		16X419	1095/1595 Models	
27	120583	NUT, hand (1095/1595 only)	1		16X421	Mark V Models	
28	114672	WASHER, thrust	2	93	244240	HOSE, drain; <i>includes 87</i>	1
29	278083	GUIDE, hose, ultra platinum	1	94		HOSE, coupled	1
30	114699	WASHER, thrust	1		16X904	1095/1595	
31	118444	SCREW, mach, slot hex wash hd	5		24V029	Mark V; <i>includes 19</i>	
35	117633	SCREW, slot hex wash hd	2	103	287253	TOOL BOX; <i>includes 104</i>	1
36	116192	WASHER, thrust, 1595	1	104	118852	SCREW, thd forming, hex washer hd	3
37	100057	SCREW, cap, hex hd	4	105	16X698	HANGER, stand, cart	1
39	24J081	TUBE, formed, ultra, platinum	1	106	15C982	CAM, cart	2
41		FITTING, pump, QD	1	107	114531	SCREW, mach, hex washer hd	4
	16Y579	1095/1595		108	16X385	PLATE, front, 5900 PCII	
	16X834	Mark V		109	118494	PACKING, o-ring	1
48	189920	STRAINER, (1-11 1/2 npsm)	1	110	16X981	LABEL, ProContractor Series	1
51	24V024	COVER, drive, plastic, painted; <i>includes 31</i>	1	117	187437	LABEL, torque	1
55	16C457	HANGER, pail	1	123	276980	GROMMET, cover	2
56	16X324	CLAMP, pump, large	1	124	119250	SCREW, shoulder	3
58	287282	SHIELD, motor, painted; <i>includes 123, 124</i>	1	126	15D088	FAN, motor	1
62	24P669	FRAME, platinum, 1095/MARK V	1	127	115477	SCREW, mach, torx pan hd	1
71		LABEL, brand, front	1	128▲	222385	TAG, warning (not shown)	
	16X368	1095 Ultra		159	278075	BRACKET, wire	1
	16X371	1595 Ultra		160	15Y118	LABEL, Made in the USA	1
	16X360	Mark V TexSpray					
	16X790	1095 Ultimate					
	16X792	1595 Ultimate					
72		LABEL, brand, side	1				
	16X369	1095 Ultra					
	16X370	1595 Ultra					
	16X361	Mark V TexSpray					
	16X791	1095 Ultimate					

▲ Extra Danger and Warning tags and labels available free.

Mark X ProContractor

Ref.	Torque
①	40-45 in-lb (4.5 - 5.0 N•m)
②	55-60 in-lb (6.2 - 6.7 N•m)
③	200-230 in-lb (22.6 - 25.9 N•m)
④	190-210 in-lb (21.4 - 23.7 N•m)
⑤	120-130 in-lb (13.5 - 14.6 N•m)
⑥	25-30 ft-lb (33.8 - 40.6 N•m)
⑦	38-42 ft-lb (51.5 - 56.9 N•m)
⑧	130-150 in-lb (14.6 - 16.9 N•m)
⑨	30-35 in-lb (3.4 - 4.0 N•m)
⑩	90-110 in-lb (10.1 - 12.4 N•m)

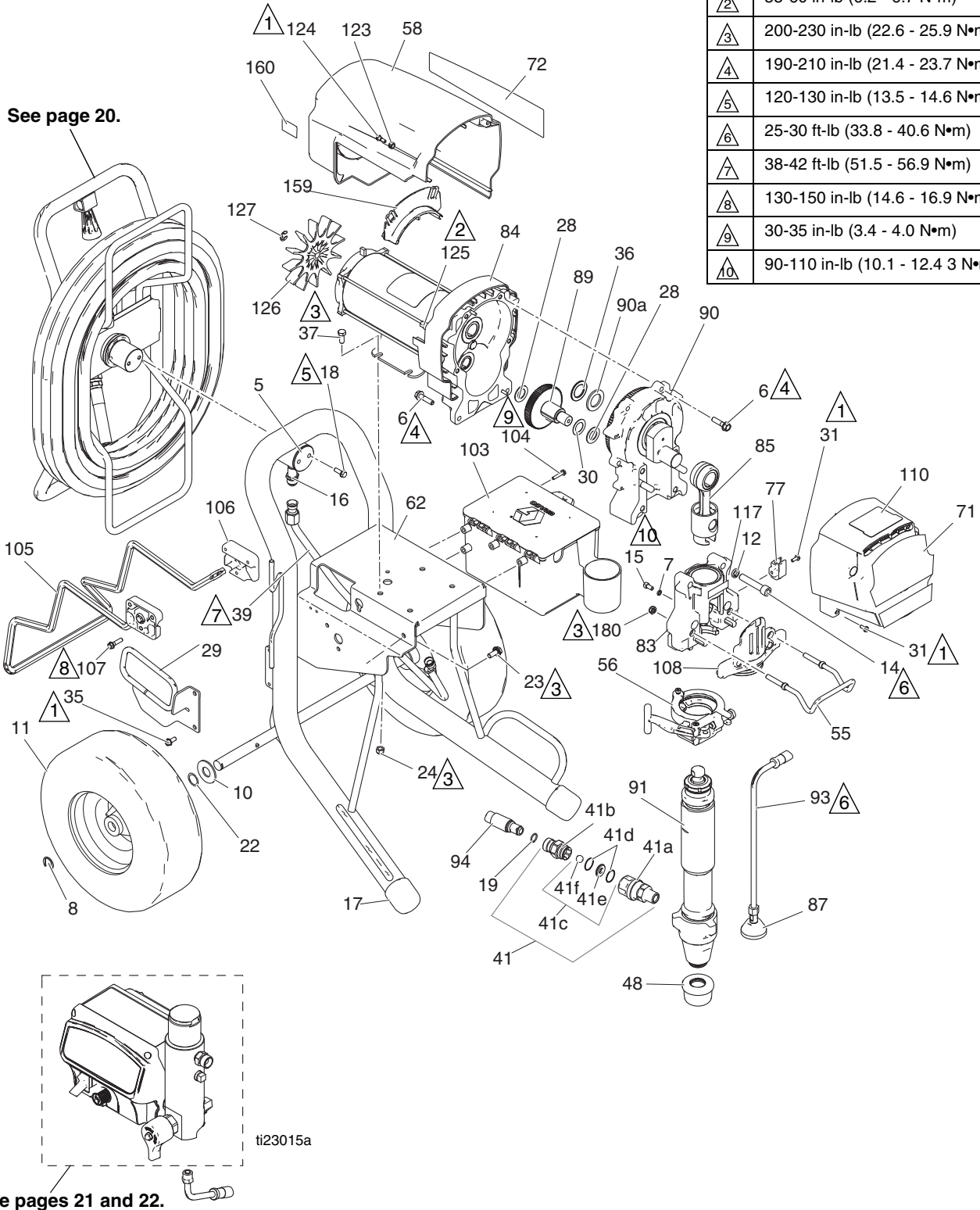

Mark X ProContractor

Ref.	Part	Description	Qty.	Ref.	Part	Description	Qty.
5	16C975	PLATE, pivot	1	71	16X362	LABEL, front	1
6	15C753	SCREW, mach, hex wash hd	6	72	16X363	LABEL, right side	1
7	105510	WASHER, lock, spring	2	77	16X203	CLIP, drain line	1
8	15E891	CLIP, retaining	2	83	24V089	HOUSING, bearing; <i>includes 7, 12, 14, 15, 31, 55, 56, 77, 108, 117, 180</i>	1
10	156306	WASHER, flat	2				
11	119509	WHEEL, pneumatic	2				
12	112600	WASHER, lock (hi-collar)	4	84	258909	MOTOR, electric; <i>includes 125, 126, 127</i>	1
14	112599	SCREW, cap, socket head	4				
15	101550	SCREW, cap, sch	2	85	24V086	ROD, connecting	1
16	121311	FITTING, connector	1	87	241920	DEFLECTOR, threaded	1
17	276974	CAP, leg	2	89	288035	GEAR, combination; <i>includes 28, 30</i>	1
18	260212	SCREW, hex washer, hd	2				
19	102982	O-RING	1	90	287990	HOUSING, drive; <i>includes 6, 36, 90a</i>	1
22	116038	WASHER, wave spring	2				
23	117791	SCREW, cap, tri lobe	2	90a	194173	WASHER, race, thrust	1
24	111040	NUT, lock, insert	4	91	16X427	PUMP, displacement	1
28	114672	WASHER, thrust	2	93	244240	HOSE, drain; <i>includes 87</i>	1
29	24M197	GUIDE, hose, ultra platinum	1	94	24V029	KIT, hose, cpld, 1/2 in.; <i>includes 19</i>	1
30	114699	WASHER, thrust	1	103	287253	TOOL BOX; <i>includes 104</i>	1
31	118444	SCREW, mach, slot hex wash hd	5	104	118852	SCREW, thd forming, hex washer hd	3
35	117633	SCREW, slot hex wash hd	2	105	16X698	HANGER, stand, cart	1
36	116192	WASHER, thrust, 1595	1	106	15C982	CAM, cart	2
37	100057	SCREW, cap, hex hd	4	107	114531	SCREW, mach, hex washer hd	4
39	16M441	TUBE, formed, ultra, platinum	1	108	16X209	PLATE, front, PCII, 7900	1
41	24U755	FITTING	1	110	16X981	LABEL, ProContractor Series	1
41a	16N461	HOUSING, seat, check valve	1	117	187437	LABEL, torque	1
41b	16X837	HOUSING, ball, check valve	1	123	276980	GROMMET, cover	2
41c	24M725	KIT, repair, check valve; <i>includes 41d, 41e, 41f</i>	1	124	119250	SCREW, shoulder	3
41d		O-RING	1	125	15G845	SPACER, standoff	2
41e		SEAT	1	126	15V577	FAN, motor	1
41f		BALL	1	127	122347	RING, retaining	1
48	189920	STRAINER, (1-11 1/2 npsm)	1	128▲	222385	TAG, warning (not shown)	
51	24V025	COVER, drive, plastic, painted; <i>includes 31</i>	1	159	278075	BRACKET, wire	1
55	16C457	PACKING, o-ring	1	160	15Y118	LABEL, Made in the USA	1
56	16X324	CLAMP, pump, large	1	180	112746	NUT, lock, thin pattern	2
58	287282	SHIELD, motor, painted; <i>includes 123, 124</i>	1				
62	24P669	FRAME, platinum, 1095/MARK V	1				

▲ Extra Danger and Warning tags and labels available free.

1095/1595/Mark V IronMan

Ref.	Torque
	40-45 in-lb (4.5 - 5.0 N•m)
	9-11 in-lb (1.0 - 1.2 N•m)
	200-230 in-lb (22.6 - 25.9 N•m)
	190-210 in-lb (21.4 - 23.7 N•m)
	90-110 in-lb (10.1 - 12.4 N•m)
	25-30 ft-lb (33.8 - 40.6 N•m)

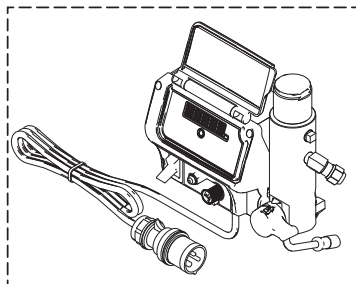
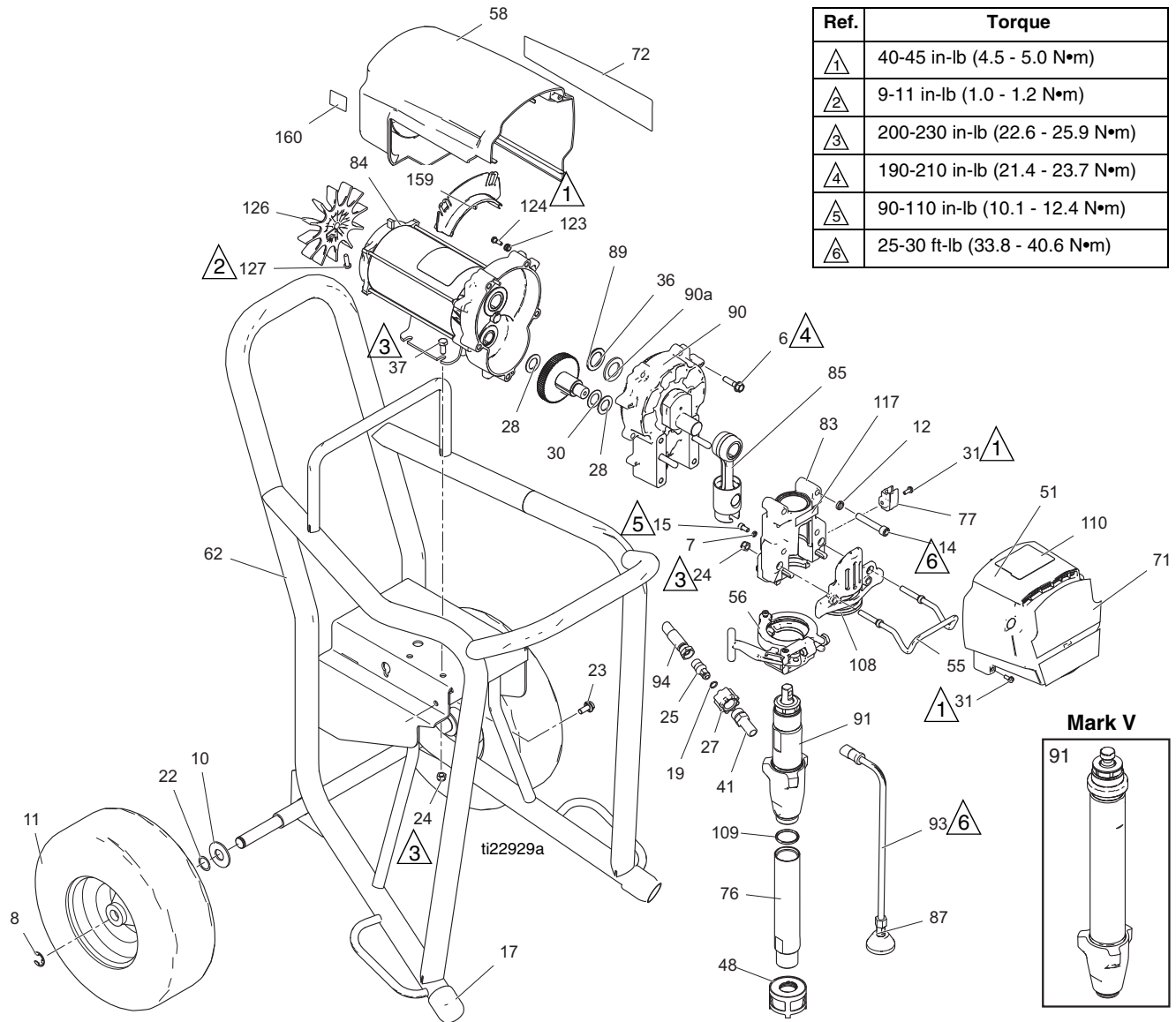

See pages 21 and 22.

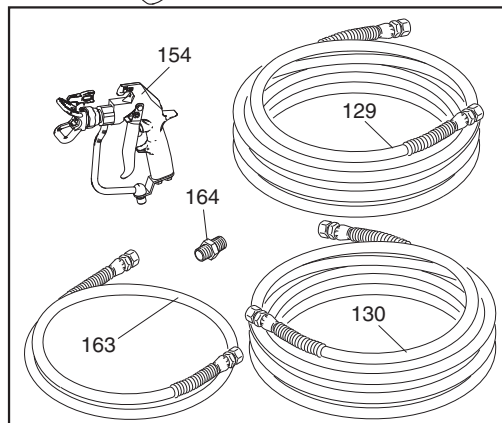

1095/1595

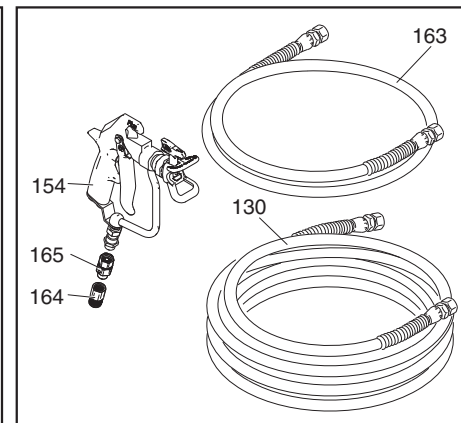

Mark V

1095/1595/Mark V IronMan

Ref.	Part	Description	Qty.	Ref.	Part	Description	Qty.
6	15C753	SCREW, mach, torx, hex	5	85	24V085	ROD, connecting	1
7	105510	WASHER, lock, spring	2	87	241920	DEFLECTOR, threaded	1
8	120211	CLIP, retaining	2	89	287290	GEAR, combination; <i>includes 28, 30</i>	1
10	156306	WASHER, flat	2	90		HOUSING, drive, M1; <i>includes 6, 36, 90a</i>	1
11	122267	WHEEL, foam	2		287294	1095	
12	106115	WASH, lock, spring	4		287295	1595/Mark V	
14	114666	SCREW, cap, socket hd	4	90a	194173	WASHER, race, thrust	1
15	101550	SCREW, cap, sch	2	91		PUMP, displacement	1
17	15C871	CAP, leg	2		16X420	1095/1595; <i>includes 41, 109</i>	
19		PACKING, o-ring	1		16Y599	Mark V	
	107505	1095/1595		93	244240	HOSE, drain; <i>includes 87</i>	1
	102982	Mark V		94		HOSE, coupled	1
22	116038	WASHER, wave spring	2		16X904	1595/1595	
23	117791	SCREW, cap, flng hd	2		24V029	Mark V; <i>includes 19</i>	
24	111040	NUT, lock, insert	6	108	16X385	PLATE, front, 5900, PCII	
25	16X833	FITTING, QD, 3/8 npsm, 1095/1595	1	109	118494	PACKING, o-ring	1
27	120583	NUT, hand, 1095/1595	6	110	16X982	LABEL, IronMan series	1
28	114672	WASHER, thrust	2	117	187437	LABEL, torque	1
30	114699	WASHER, thrust	1	123	276980	GROMMET, cover	2
31	118444	SCREW, machine, hex washer hd	5	124	119250	SCREW, shoulder, hex, washer	3
36	116192	WASHER, thrust	1	126	15D088	FAN, motor	1
37	100057	SCREW, cap, hex hd	4	127	115477	SCREW, mach, torx, pan, hd	1
41		FITTING, pump, QD	1	128▲	222385	TAG, WARNING (not shown)	1
	16Y579	1095/1595		129		HOSE, cpld, 1/4 in. x 50 ft	1
	16X834	Mark V			240794	1095/1595 Ultra	
48	15V573	STRAINER, (1-11 1/2 NPSM)	1		826079	1095/1595 Ultimate	
51	24V024	COVER, drive, plastic, painted; <i>includes 31</i>	1	130		HOSE, cpld, 3/8 in. x 50 ft	
55	16C457	HANGER, pail	1		240797	1095/1595/Ultimate	1
56	16X324	CLAMP, pump, large	1		240797	Mark V	2
58	287282	SHIELD, motor, painted; <i>includes 123, 124</i>	1		826080	1095/1595 Ultimate	1
62	16X711	FRAME, cart, 1095/1595	1	154		GUN	1
71		LABEL, UltraMax	1		246240	1095/1595	
	16X368	Ultra 1095			241705	Mark V	
	16X371	Ultra 1595		159	278075	BRACKET, wire	
	16X790	Ultimate 1095		160	15Y118	LABEL, Made in USA	1
	16X792	Ultimate 1595		163		HOSE, coupled	1
	16X360	TexSpray/Mark V			277322	1095/1595	
72		LABEL, UltraMax II, 1095/1595	1		241735	Mark V	
	16X369	Ultra 1095		164		FITTING	1
	16X370	Ultra 1595			164672	1095/1595	
	16X791	Ultimate 1095			159841	Mark V	
	16X793	Ultimate 1595		165	189018	SWIVEL, assembly	1
	16X361	TexSpray Mark V					
76	248215	TUBE, intake; <i>includes 109</i>	1				
77	16X203	CLIP, drain line	1				
83	24V088	HOUSING, bearing; <i>includes 7, 12, 14, 15, 24, 31, 55, 56, 77, 108, 117</i>	1				
84		MOTOR, electric; <i>includes 126, 127</i>	1				
	257187	1095					
	257188	1595/Mark V					

▲ Extra Danger and Warning tags and labels available free.

Hose Reel and Gun

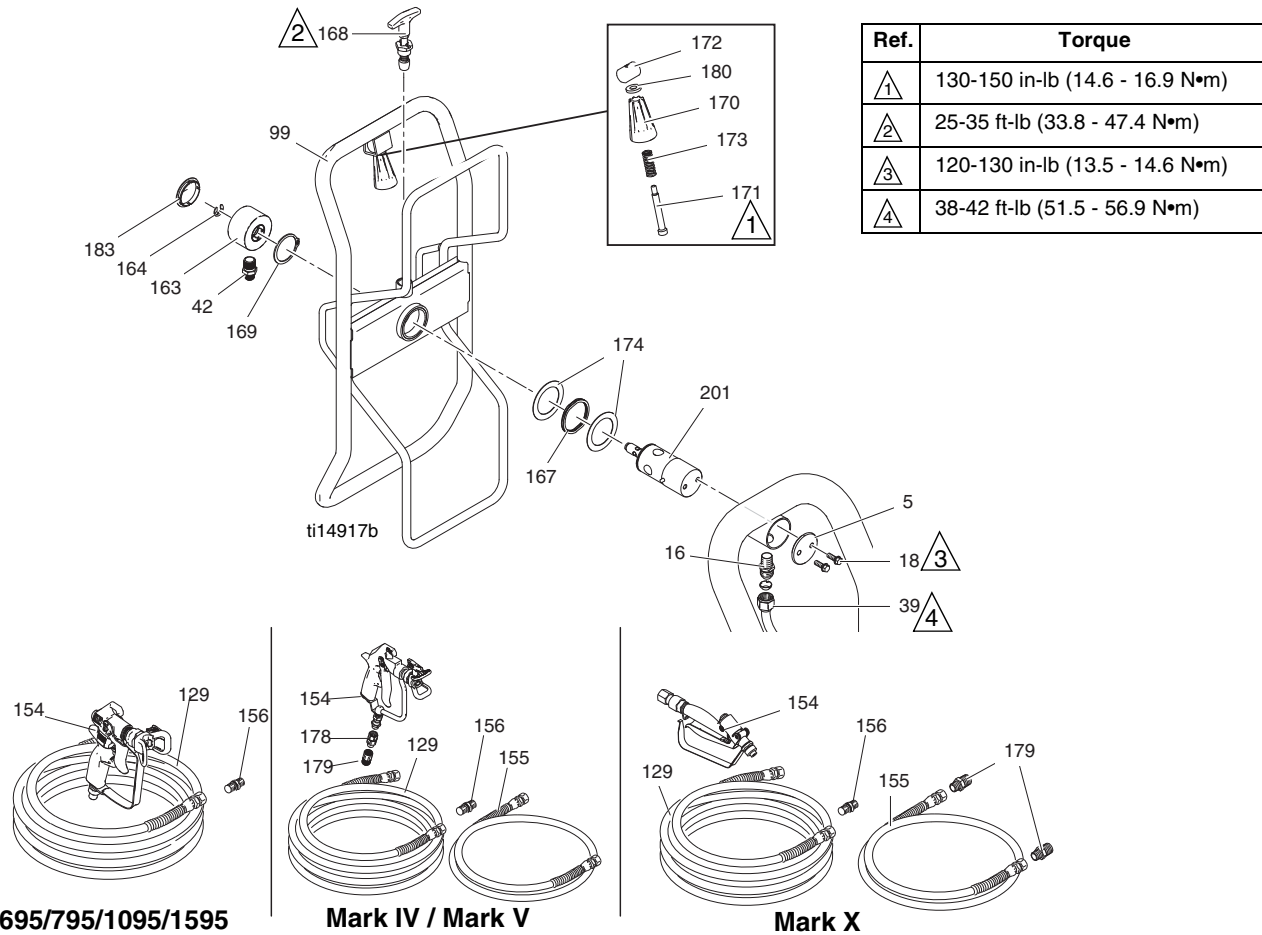

Parts List

Ref.	Part	Description	Qty.	Ref.	Part	Description	Qty.
5	16C975	PLATE, Pivot Mount	1	155		HOSE, whip	1
16	121311	FITTING, Connector, NPT x JIC	1	241735		Mark IV, Mark V	
18	260212	SCREW, Hex Washer HD	2	191239		Mark X	
39		TUBE, Formed, Ultra, Platinum	1	156		ADAPTER	1
	24V095	695/795 Models		162453		695/795/1095/1595	
	24J081	1095/Mark V Models		196178		Mark IV/Mark V	
	16M441	Mark X		158491		Mark X	
42		ADAPTER	1	163	24B248	CAP, swivel, complete	1
	164672	695/795/1095/1595		164	122347	RING, retaining, external	1
	196178	Mark IV/Mark V		167	122534	SPRING, wave	1
	159239	Mark X		168	24E400	PIN, pop, lock out	1
99	24B691	REEL, hose, ultra	1	169	122524	RING, retaining, external	1
129		HOSE, coupled		170	278085	HANDLE, swivel	1
	240794	695/795/1095/1595 Ultra	2	171	122518	PIN	1
	826079	695/795/1095/1595 Ultimate	2	172	15X618	NUT, pin	1
	245225	Mark IV/Mark V	2	173	122542	SPRING	1
	278499	Mark X	2	174	122607	WASHER, flat	2
154		GUN, spray		178	189018	SWIVEL	1
	288420	695/795/1095/1595 Ultra	1	179		BUSHING	
	826085	695/795/1095/1595 Ultimate	1	159841		Mark IV/Mark V	1
	241705	Mark V Models	1	159239		Mark X	2
	246468	Mark IV Models	1	180	122669	WASHER	1
	245820	Mark X	1	183	122787	CAP	1
				201	24E016	TUBE, Hose Reel, Pivot	1

Control Box

Ref.	Torque
1	10-15 in-lb (1.1 - 1.7 N•m)
2	40-45 in-lb (4.5 - 5.0 N•m)
3	22-28 in-lb (2.4 - 3.1 N•m)
4	200-230 in-lb (22.6 - 25.9 N•m)
5	30-35 in-lb (3.3 - 3.9 N•m)
6	15-20 in-lb (1.7 - 2.2 N•m)
7	2-3 in-lb (0.2 - 0.4 N•m)

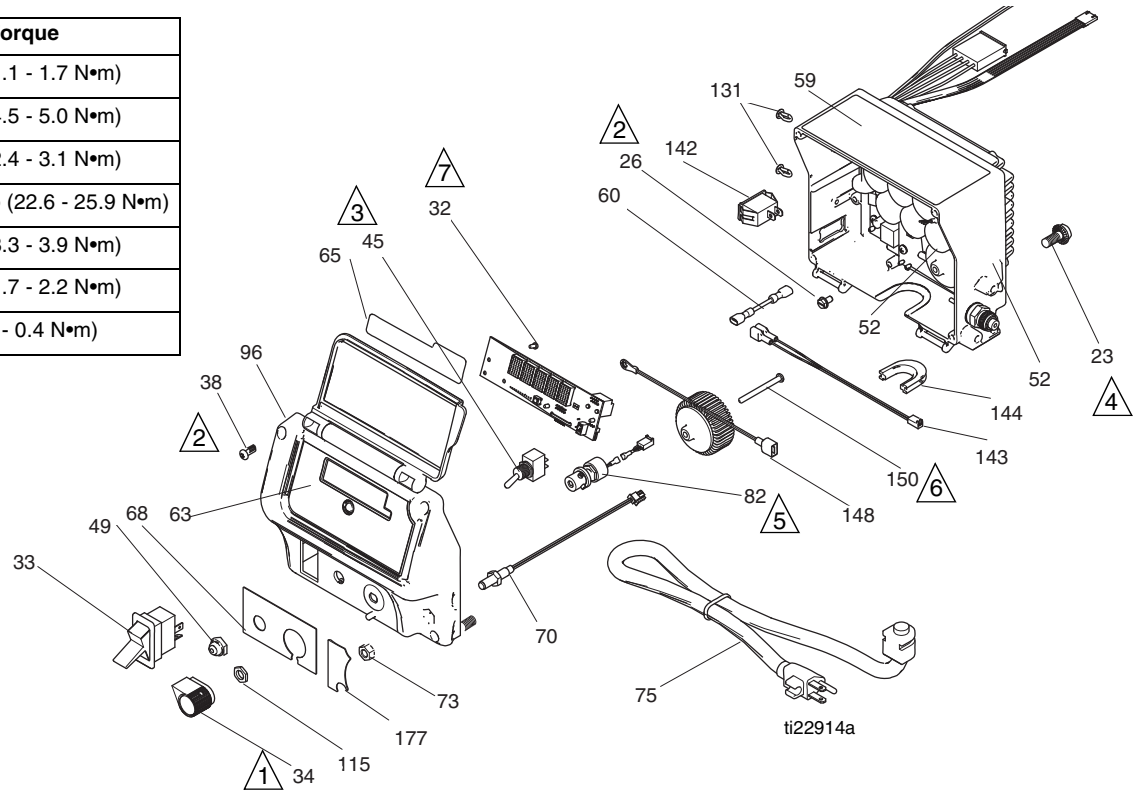

Parts List

Ref.	Part	Description	Qty.	Ref.	Part	Description	Qty.	
23	117791	SCREW, cap, flange head	2	16Z019	LIGHT, ProGuard (Standard series)	1		
26	114391	SCREW, grounding	1	73	100187	NUT	1	
32	115522	SCREW, mach, pnh (ProContractor/IronMan series)	3	75		CORD, power	1	
33	15C979	SWITCH, rocker	1	15H064	120V Models 695, 795, 1095, Mark IV			
	15D527	SWITCH, rocker, Mark X	1	15H065	120V Models 1595, Mark V			
34	116167	KNOB, potentiometer	1	15R876	Mark X			
38	16V095	SCREW, #10, taptite phil	4	15H066	120V CSA Models 1595, Mark V			
45	119541	SWITCH, toggle, (ProContractor/IronMan series)	1	82	256219	POTENTIOMETR, assembly	1	
49	195428	BOOT, toggle (ProContractor/IronMan series)	1	96		COVER, control	1	
52		CONTROL, board; <i>includes 23, 26, 60, 131, 142, 144</i>	1	24V061	ProContractor/IronMan series; <i>includes 32, 38, 63, 65, 68</i>			
	24P847	120V Models		24V062	Standard series; <i>includes 38, 63, 68</i>			
59▲	16T784	LABEL, warning, domestic	1	115	15C973	GASKET	1	
60	16T541	JUMPER WIRE	1	131	16T482	RIVET, snap	2	
63	16X796	LABEL, LCD, GMAX (ProContractor/IronMan series)	1	142		SWITCH/PLUG	1	
	16Y785	LABEL, control box cover, ultra (Standard series)	1	16T483	695/795/1095/Mark IV/Mark X			
65	16X797	LABEL, control box cover, ultra (ProContractor/IronMan series)	1	120059	1595/Mark V			
	68	16Y789	LABEL, control (ProContractor/IronMan series)	1	143	15G935	CONNECTOR, electrical (1595/Mark V)	1
		16Y786	LABEL, control (Standard series)	1	144		STRAIN RELIEF	1
		16Y786	LABEL, control (Standard series)	1	16T547	695/795/1095/Mark IV		
70	122507	SWITCH, reed (ProContractor/IronMan series)	1	116171	1595/Mark V/Mark X			
				148	24V030	KIT, repair, coil; <i>includes 150</i>	1	
				150	16U215	SCREW, machine, flat head	1	
				177	16Y791	LABEL, blank, elec, std (Standard)	1	
					16Y790	ProContractor/IronMan	1	
					16Y788	Mark X ProContractor	1	

▲ Extra Danger and Warning tags and labels available free.

Filter

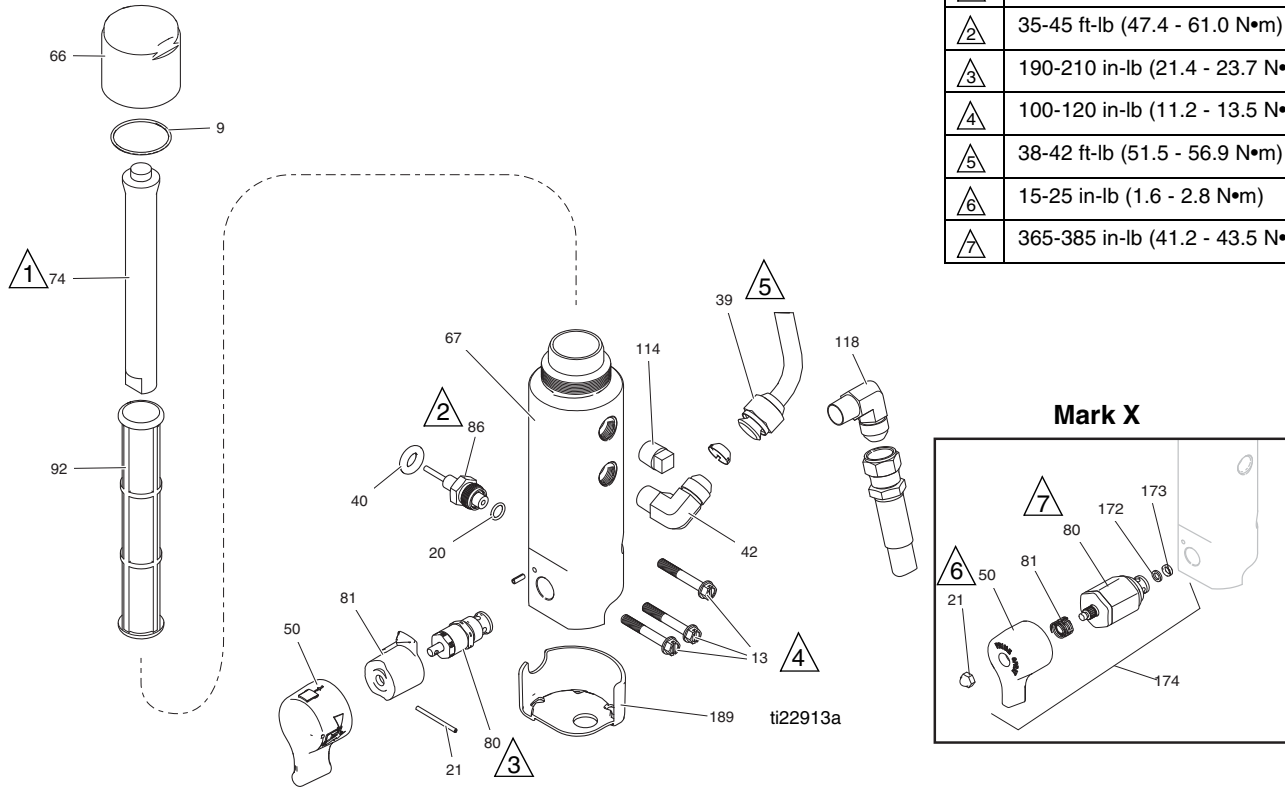

Ref.	Torque
1	90-110 in-lb (10.1 - 12.4 N•m)
2	35-45 ft-lb (47.4 - 61.0 N•m)
3	190-210 in-lb (21.4 - 23.7 N•m)
4	100-120 in-lb (11.2 - 13.5 N•m)
5	38-42 ft-lb (51.5 - 56.9 N•m)
6	15-25 in-lb (1.6 - 2.8 N•m)
7	365-385 in-lb (41.2 - 43.5 N•m)

Parts List

Ref.	Part	Description	Qty.	Ref.	Part	Description	Qty.
9	117285	PACKING, o-ring	1	67	16T543	BASE, filter	1
13	16U013	SCREW, cap, socket head	3	74	15C766	TUBE, diffusion	1
20	111457	PACKING, o-ring	1	80	24B156	VALVE, prime, HD	1
21	15C972	PIN, grooved	1	287879	VALVE, prime, Mark X	1	
	116424	NUT, Mark X	1	81	BASE, valve	1	
39		TUBE, formed	1	24A382	Standard series		
	24V095	695/795 Models		24D286	ProContractor/IronMan		
	24J081	1095/Mark V Models		114708	Mark X		
	16M441	Mark X		86	243222	TRANSDUCER, pressure control;	
40	121889	GROMMET, transducer	1		<i>includes 20</i>	1	
42		FITTING	1	92		FILTER, fluid	1
	122533	1095/1595/Mark V		244071	30 mesh		
		(ProContractor series)		244067	60 mesh, original equipment		
	125926	695/795/Mark IV/Mark X		244068	100 mesh		
		(ProContractor series)		244069	200 mesh		
	164672	695/795/1095/1595 (Standard series)		114	104813	PLUG, pipe	1
	196178	Mark IV/Mark V (Standard series)		118	125926	FITTING, elbow	1
		1095/1595/Mark V (IronMan series)		172	193709	SEAT, valve	1
	183285	Mark X (Standard series)		173	193710	SEAL, seat, valve	1
50		KIT, handle; <i>includes 21, 81</i>	1	174	245103	KIT, repair, valve, Mark X;	1
	24E233	ProContractor/IronMan Series			<i>includes 21, 50, 80, 81, 172, 173</i>		
	24E234	Standard Series		189	17A197	GUARD, base, filter (ProContractor/IronMan Series)	
	15G563	Mark X					
66	15C765	CAP, filter	1				

Graco Standard Warranty

Graco warrants all equipment referenced in this document which is manufactured by Graco and bearing its name to be free from defects in material and workmanship on the date of sale to the original purchaser for use. With the exception of any special, extended, or limited warranty published by Graco, Graco will, for a period of twelve months from the date of sale, repair or replace any part of the equipment determined by Graco to be defective. This warranty applies only when the equipment is installed, operated and maintained in accordance with Graco's written recommendations.

This warranty does not cover, and Graco shall not be liable for general wear and tear, or any malfunction, damage or wear caused by faulty installation, misapplication, abrasion, corrosion, inadequate or improper maintenance, negligence, accident, tampering, or substitution of non-Graco component parts. Nor shall Graco be liable for malfunction, damage or wear caused by the incompatibility of Graco equipment with structures, accessories, equipment or materials not supplied by Graco, or the improper design, manufacture, installation, operation or maintenance of structures, accessories, equipment or materials not supplied by Graco.

This warranty is conditioned upon the prepaid return of the equipment claimed to be defective to an authorized Graco distributor for verification of the claimed defect. If the claimed defect is verified, Graco will repair or replace free of charge any defective parts. The equipment will be returned to the original purchaser transportation prepaid. If inspection of the equipment does not disclose any defect in material or workmanship, repairs will be made at a reasonable charge, which charges may include the costs of parts, labor, and transportation.

THIS WARRANTY IS EXCLUSIVE, AND IS IN LIEU OF ANY OTHER WARRANTIES, EXPRESS OR IMPLIED, INCLUDING BUT NOT LIMITED TO WARRANTY OF MERCHANTABILITY OR WARRANTY OF FITNESS FOR A PARTICULAR PURPOSE.

Graco's sole obligation and buyer's sole remedy for any breach of warranty shall be as set forth above. The buyer agrees that no other remedy (including, but not limited to, incidental or consequential damages for lost profits, lost sales, injury to person or property, or any other incidental or consequential loss) shall be available. Any action for breach of warranty must be brought within two (2) years of the date of sale.

GRACO MAKES NO WARRANTY, AND DISCLAIMS ALL IMPLIED WARRANTIES OF MERCHANTABILITY AND FITNESS FOR A PARTICULAR PURPOSE, IN CONNECTION WITH ACCESSORIES, EQUIPMENT, MATERIALS OR COMPONENTS SOLD BUT NOT MANUFACTURED BY GRACO. These items sold, but not manufactured by Graco (such as electric motors, switches, hose, etc.), are subject to the warranty, if any, of their manufacturer. Graco will provide purchaser with reasonable assistance in making any claim for breach of these warranties.

In no event will Graco be liable for indirect, incidental, special or consequential damages resulting from Graco supplying equipment hereunder, or the furnishing, performance, or use of any products or other goods sold hereto, whether due to a breach of contract, breach of warranty, the negligence of Graco, or otherwise.

FOR GRACO CANADA CUSTOMERS

The Parties acknowledge that they have required that the present document, as well as all documents, notices and legal proceedings entered into, given or instituted pursuant hereto or relating directly or indirectly hereto, be drawn up in English. Les parties reconnaissent avoir convenu que la rédaction du présente document sera en Anglais, ainsi que tous documents, avis et procédures judiciaires exécutés, donnés ou intentés, à la suite de ou en rapport, directement ou indirectement, avec les procédures concernées.

Graco Information

For the latest information about Graco products, visit www.graco.com.

For patent information, see www.graco.com/patents.

TO PLACE AN ORDER, contact your Graco distributor or call 1-800-690-2894 to identify the nearest distributor.

All written and visual data contained in this document reflects the latest product information available at the time of publication. Graco reserves the right to make changes at any time without notice.

Original instructions. This manual contains English. MM 332918

Graco Headquarters: Minneapolis

International Offices: Belgium, China, Japan, Korea

GRACO INC. AND SUBSIDIARIES • P.O. BOX 1441 • MINNEAPOLIS MN 55440-1441 • USA

Copyright 2014, Graco Inc. All Graco manufacturing locations are registered to ISO 9001.

www.graco.com

Revision D - April, 2014