

G3 Reservoir and O-Ring Replacement Kit

3A0534F

EN

Instructions for replacing G3 reservoir and o-rings. For professional use only.

Part No.:

571042, 571069, 571179 - 2 Liter models

571182, 571183 - 4 Liter models



Important Safety Instructions

Read all warnings and instructions in this manual and the G3 Pump Instruction manual included with your unit. Save these instructions.

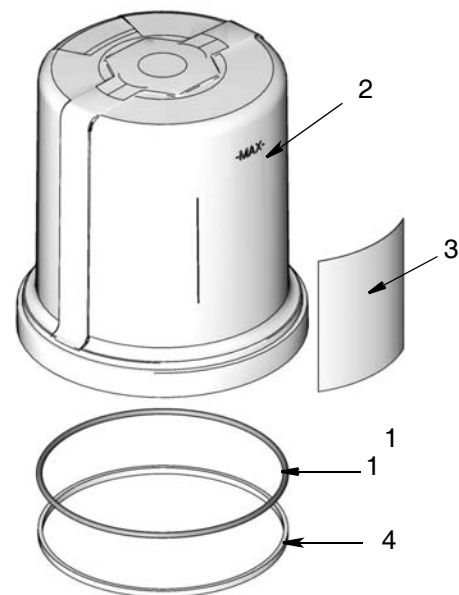
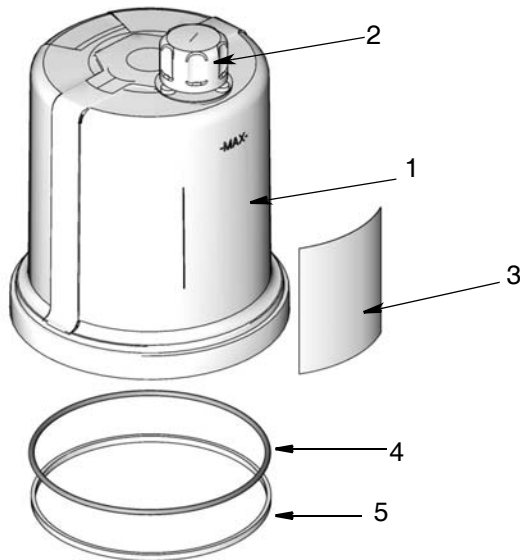

Kit Parts 571179, 571182



Ref.	Description	Qty
1	RESERVOIR	1
2	CAP, oil, fill	1
3	LABEL	1
4	O-RING	1
5	O-RING, square	1

Kit Parts 571042, 571069, 571183

Ref.	Description	Qty
1	O-RING	1
2	RESERVOIR	1
3	LABEL	1
4	O-RING, square	1

Instructions

Pressure Relief

					
SKIN INJECTION HAZARD					
High-pressure fluid from dispense device, hose leaks, or ruptured components will pierce skin. This may look like just a cut, but it is a serious injury that can result in amputation. Get immediate surgical treatment.					
Follow Pressure Relief Procedure in this manual, when you stop dispensing and before cleaning, checking, or servicing equipment.					

Relieve pressure in system by using two wrenches working in opposite directions on pump element and pump element fitting to **only** loosen fitting.

NOTE: When loosening pump element fitting, do NOT loosen **pump element**. Loosening pump element will change the output volume.

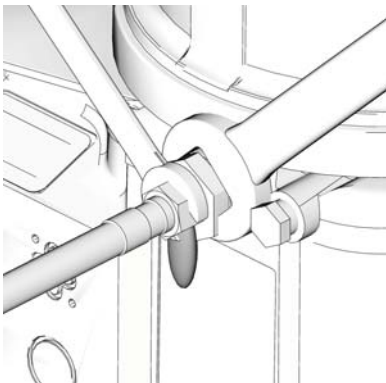

FIG. 1

Disassembly

Reference numbers used in these instructions correspond to parts included in Kit and are provided on page 1. Parts identified with an alpha character are user provided or already installed components.

Reservoir Disassembly

1. Disconnect power source.
2. Relieve pressure using Pressure Relief Procedure provided.

3. Use a strap wrench around reservoir to turn reservoir 1/4 turn counter-clockwise (FIG. 2).

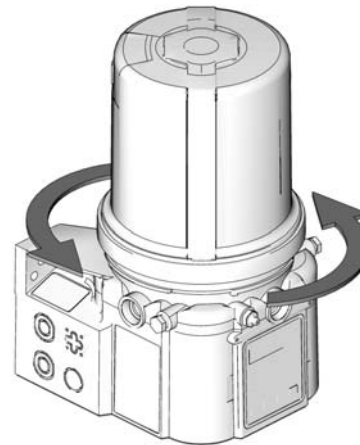

FIG. 2

4. Remove reservoir from G3 base and discard reservoir according to local codes for proper disposal.

NOTE: If your unit includes a follower plate, remove any parts noted in Step 1 of the Follower Plate Disassembly section and keep those parts for reassembly.

Follower Plate Disassembly

If your unit does not have a follower plate, continue disassembly with O-Ring Disassembly instructions, page 3.

1. Verify the following parts were removed with reservoir (FIG. 3):
 - Spring (S)
 - Follower Plate (FP)
 - Follower Plate Seal (FPS)
 - Rod (R)

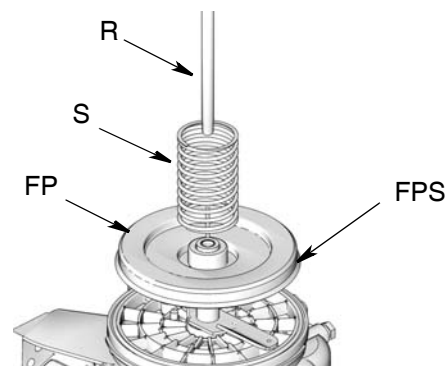

FIG. 3

2. Remove any parts still installed in the G3 base.

3. Be sure parts remaining in reservoir were removed to reuse them for reassembly.
4. Examine follower plate seal referenced in Step 1 for wear or damage. If it is damaged, it must be replaced. Part No. 278139 is available from Graco. Contact customer service to order this part or your local Graco distributor.

Upper O-Ring Disassembly

If o-ring (a) did not come out of the groove in ricer plate (b) when reservoir was removed, remove and discard o-ring according to local codes for proper disposal (FIG. 4).

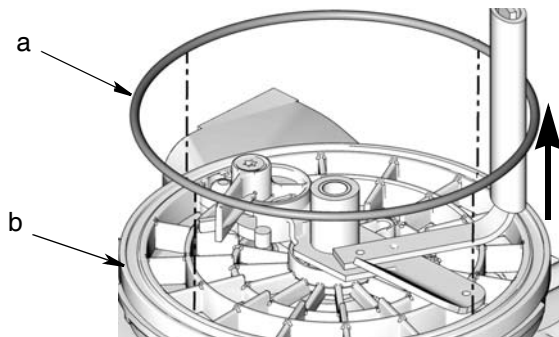

FIG. 4

The lower o-ring is located beneath the ricer plate (b). If replacing this o-ring, continue with Lower O-Ring Disassembly instructions.

If lower o-ring is not replaced, begin Reassembly instructions starting on page 4.

Lower O-Ring Disassembly Instructions

1. Perform all applicable previous disassembly instructions for reservoir, follower plate (if applicable) and upper o-ring.
2. Turn paddle (c) **clockwise** to loosen and remove it from G3 base (FIG. 5).

NOTE: For models that include a Low Level paddle and/or follower plate only, be careful when removing stirring paddle from G3 that bearing (f) does not fall into the unit.

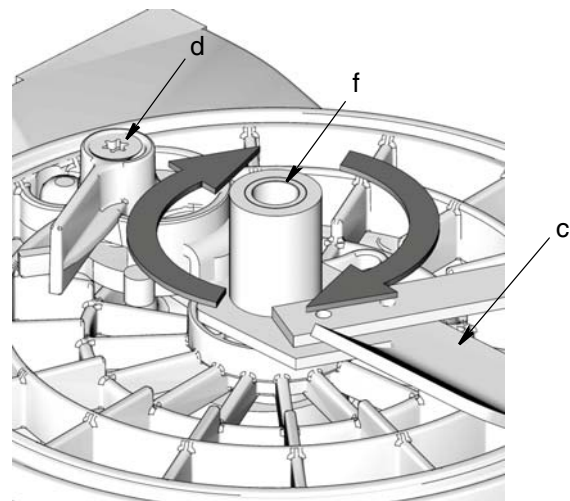

FIG. 5

3. Remove ricer plate (b) from G3 base.

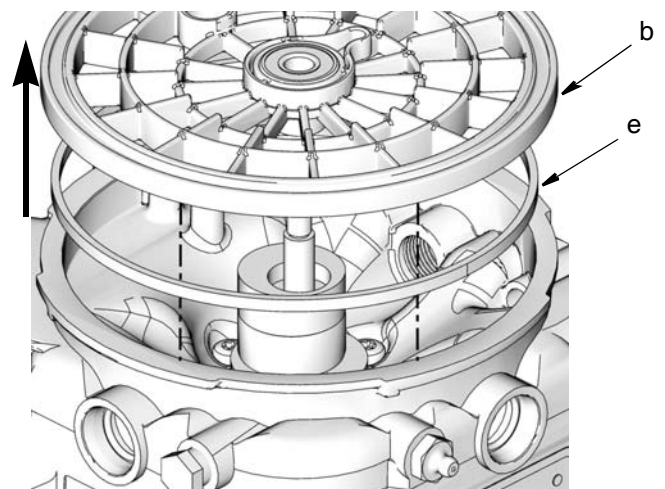

FIG. 6

4. Remove o-ring (e) located under ricer plate (FIG. 6).

Reassembly

Lower O-Ring Installation

1. Coat new o-ring (1) with grease (user supplied) and install o-ring in bottom groove of ricer plate (b).

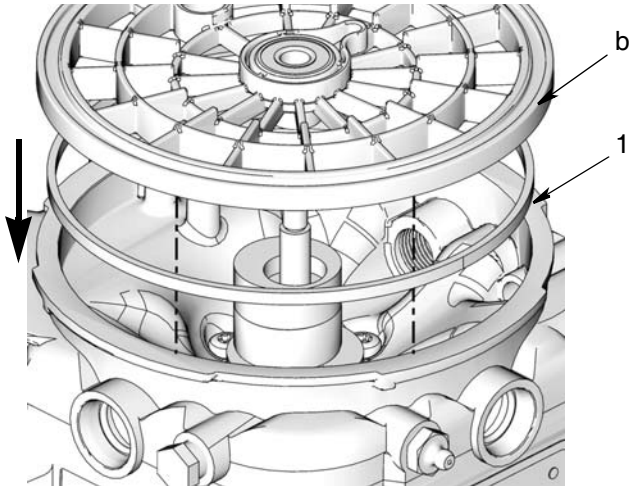

FIG. 7

2. Replace ricer plate (b), aligning circular sections with the round bosses in the base.

NOTE: It may be necessary to use a press to seat the plate properly in the G3 base.

3. Reinstall paddle (c) by turning it **counter-clockwise** till tight - hand tighten only (FIG. 8).

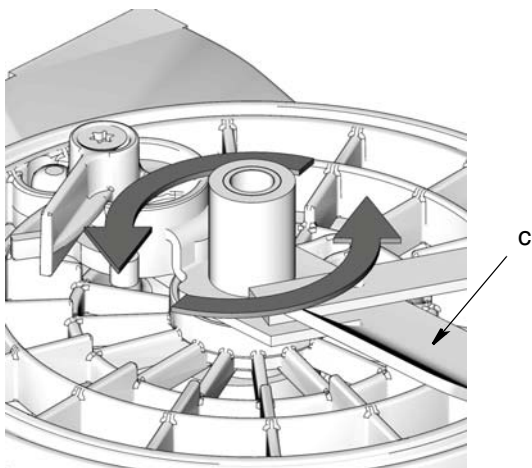

FIG. 8

NOTE: If a low level paddle (d) is installed, to prevent damage, hold low level paddle in its full out position while installing stirring paddle (FIG. 9).

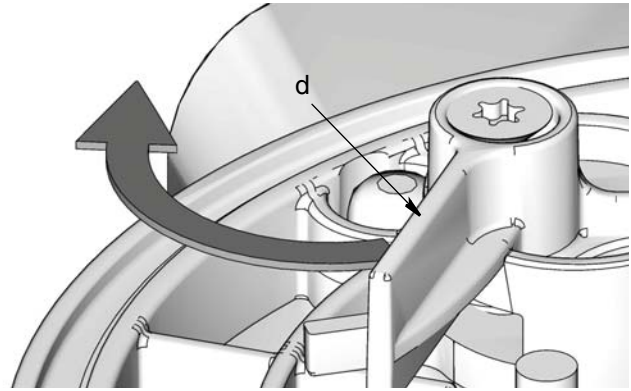

FIG. 9

4. Complete installation following instructions for Top O-Ring and Reservoir installation, page 4.

Top O-ring Installation

1. Coat new o-ring (1) with grease (user supplied).
2. Install o-ring in groove of ricer plate (b) (FIG. 10).

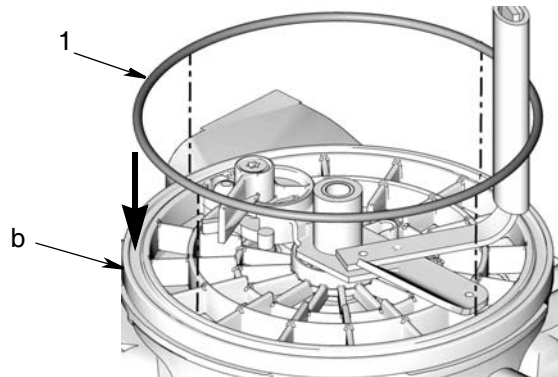

FIG. 10

Follower Plate Installation

If your unit does not have a follower plate, continue installation instructions with Top O-Ring Installation, page 5.

1. Verify low level paddle (d) is in full out position as shown in FIG. 9.
2. Install follower plate (FP) on stirring paddle (c). Be sure the seal (FPS) is facing down (toward ricer

plate) as shown in FIG. 11.

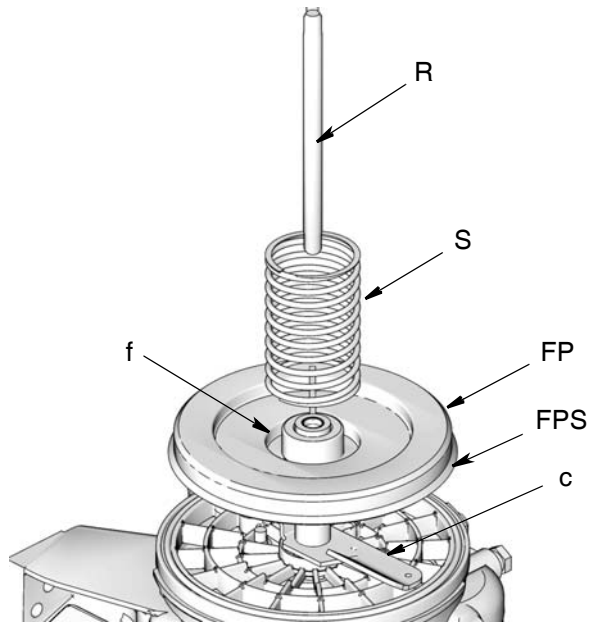

FIG. 11

3. Install spring (S) into spring pocket (f).
4. Install Rod (R) into reservoir (2).
5. Slide rod (R) through center of spring (S) and follower plate (FP).
6. Seat spring in spring pocket in top of reservoir.
7. Compress spring to install reservoir. See Reservoir Installation instructions.

Reservoir Installation

1. Install new reservoir (2) with vent (g) facing toward the rear left (h) of the G3 base. See FIG. 12 for correct orientation of these parts to ensure proper installation.

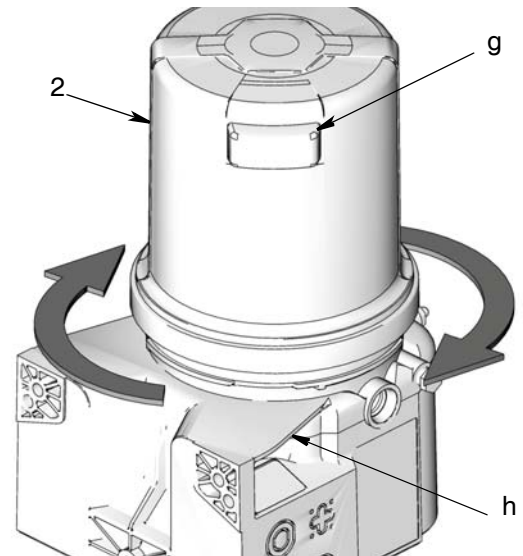

FIG. 12

2. Position strap wrench over reservoir and use it to turn reservoir 1/4 turn clockwise till reservoir will not turn any farther (FIG. 12).

NOTICE

Be careful when installing reservoir that o-ring is not pinched. If the o-ring is not correctly installed, grease could leak out of the bottom of the G3 reservoir.

*All written and visual data contained in this document reflects the latest product information available at the time of publication.
Graco reserves the right to make changes at any time without notice.*

For patent information, see www.graco.com/patents

Original instructions. This manual contains English. MM 3A0534

Graco Headquarters: Minneapolis

International Offices: Belgium, China, Japan, Korea

GRACO INC. P.O. BOX 1441 MINNEAPOLIS, MN 55440-1441

Copyright 2010, Graco Inc. is registered to ISO 9001

www.graco.com

Revised April 2014