

XM PFP Mix Manifold

3A2988B

EN

Dual flush, center inject manifold with heated water circulating base for mixing intumescent epoxies with the XM PFP system. For professional use only.

Part No. 262893

6000 psi (41 MPa, 414 bar) Maximum Working Pressure for A and B materials

4500 psi (31 MPa, 310 bar) Maximum Working Pressure for flushing fluid

100 psi (0.7 MPa, 7 bar) Maximum Working Pressure for heating fluid

180°F (82°C) Maximum Fluid Temperature



Important Safety Instructions

Read all warnings and instructions in this manual and XM PFP Operation manual. Save all instructions.

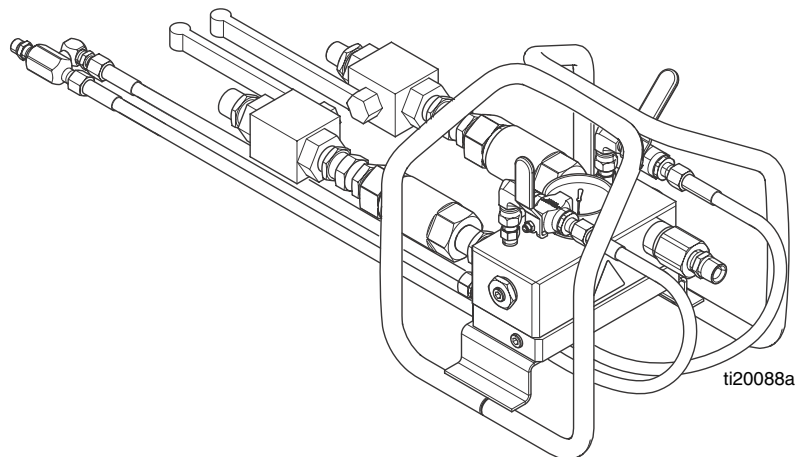

II 2 G c T5



Contents

Related Manuals 2

Warnings 3

 Keep Components A and B Separate 5

 Changing Materials 5

Component Identification 6

Overview 7

Installation 8

 Fluid Inlets 8

 Solvent Inlet 8

 Fluid Outlet 8

 Heated Manifold 8

 Mounting 8

Grounding 9

Flush Before Using Equipment 9

Operation 10

 Pressure Relief Procedure 10

 Flush 11

 Dispensing and Spraying 12

 Volume Balancing the Mix Manifold 13

Maintenance 15

 Clean Static Mixers 15

 Clean Mix Manifold Outlet 15

Troubleshooting 16

Repair 17

 Check Valves 17

Parts 18

 262890 Mix Manifold 18

Technical Data 21

Graco Standard Warranty 22

Graco Information 22



Related Manuals

Manuals are available at www.graco.com. Component Manuals in English:



Manual	Description
3A2776	XM PFP Operation
3A2989	XM PFP Repair - Parts
3A2799	XHF Spray Gun

Warnings



The following warnings are for the setup, use, grounding, maintenance, and repair of this equipment. The exclamation point symbol alerts you to a general warning and the hazard symbols refer to procedure-specific risks. When these symbols appear in the body of this manual or on warning labels, refer back to these Warnings. Product-specific hazard symbols and warnings not covered in this section may appear throughout the body of this manual where applicable.

 WARNING	
	<p>SKIN INJECTION HAZARD</p> <p>High-pressure fluid from gun, hose leaks, or ruptured components will pierce skin. This may look like just a cut, but it is a serious injury that can result in amputation. Get immediate surgical treatment.</p> <ul style="list-style-type: none"> • Do not spray without tip guard and trigger guard installed. • Engage trigger lock when not spraying. • Do not point gun at anyone or at any part of the body. • Do not put your hand over the spray tip. • Do not stop or deflect leaks with your hand, body, glove, or rag. • Follow the Pressure Relief Procedure when you stop spraying and before cleaning, checking, or servicing equipment. • Tighten all fluid connections before operating the equipment. • Check hoses and couplings daily. Replace worn or damaged parts immediately.
	<p>FIRE AND EXPLOSION HAZARD</p> <p>Flammable fumes, such as solvent and paint fumes, in work area can ignite or explode. To help prevent fire and explosion:</p> <ul style="list-style-type: none"> • Use equipment only in well ventilated area. • Eliminate all ignition sources; such as pilot lights, cigarettes, portable electric lamps, and plastic drop cloths (potential static arc). • Keep work area free of debris, including solvent, rags and gasoline. • Do not plug or unplug power cords, or turn power or light switches on or off when flammable fumes are present. • Ground all equipment in the work area. See Grounding instructions. • Use only grounded hoses. • Hold gun firmly to side of grounded pail when triggering into pail. Do not use pail liners unless they are antistatic or conductive. • Stop operation immediately if static sparking occurs or you feel a shock. Do not use equipment until you identify and correct the problem. • Keep a working fire extinguisher in the work area.

! WARNING

	<p>EQUIPMENT MISUSE HAZARD</p> <p>Misuse can cause death or serious injury.</p> <ul style="list-style-type: none"> • Do not operate the unit when fatigued or under the influence of drugs or alcohol. • Do not exceed the maximum working pressure or temperature rating of the lowest rated system component. See Technical Data in all equipment manuals. • Use fluids and solvents that are compatible with equipment wetted parts. See Technical Data in all equipment manuals. Read fluid and solvent manufacturer's warnings. For complete information about your material, request MSDS from distributor or retailer. • Do not leave the work area while equipment is energized or under pressure. • Turn off all equipment and follow the Pressure Relief Procedure when equipment is not in use. • Check equipment daily. Repair or replace worn or damaged parts immediately with genuine manufacturer's replacement parts only. • Do not alter or modify equipment. Alterations or modifications may void agency approvals and create safety hazards. • Make sure all equipment is rated and approved for the environment in which you are using it. • Use equipment only for its intended purpose. Call your distributor for information. • Route hoses and cables away from traffic areas, sharp edges, moving parts, and hot surfaces. • Do not kink or over bend hoses or use hoses to pull equipment. • Keep children and animals away from work area. • Comply with all applicable safety regulations.
	<p>TOXIC FLUID OR FUMES HAZARD</p> <p>Toxic fluids or fumes can cause serious injury or death if splashed in the eyes or on skin, inhaled, or swallowed.</p> <ul style="list-style-type: none"> • Read MSDSs to know the specific hazards of the fluids you are using. • Store hazardous fluid in approved containers, and dispose of it according to applicable guidelines.
	<p>PERSONAL PROTECTIVE EQUIPMENT</p> <p>Wear appropriate protective equipment when in the work area to help prevent serious injury, including eye injury, hearing loss, inhalation of toxic fumes, and burns. This protective equipment includes but is not limited to:</p> <ul style="list-style-type: none"> • Protective eyewear, and hearing protection. • Respirators, protective clothing, and gloves as recommended by the fluid and solvent manufacturer

Keep Components A and B Separate

						
<p>Cross-contamination can result in cured material in fluid lines which could cause serious injury or damage equipment. To prevent cross-contamination:</p> <ul style="list-style-type: none">• Never interchange component A and component B wetted parts.• Never use solvent on one side if it has been contaminated from the other side.						

Changing Materials

NOTICE

Changing the material types used in your equipment requires special attention to avoid equipment damage and downtime.

- When changing materials, flush the equipment multiple times to ensure it is thoroughly clean.
- Always clean any fluid inlet strainers after flushing.
- Check with your material manufacturer for chemical compatibility.
- When changing between epoxies and urethanes or polyureas, disassemble and clean all fluid components and change hoses. Epoxies often have amines on the B (hardener) side. Polyureas often have amines on the B (resin) side.

Component Identification

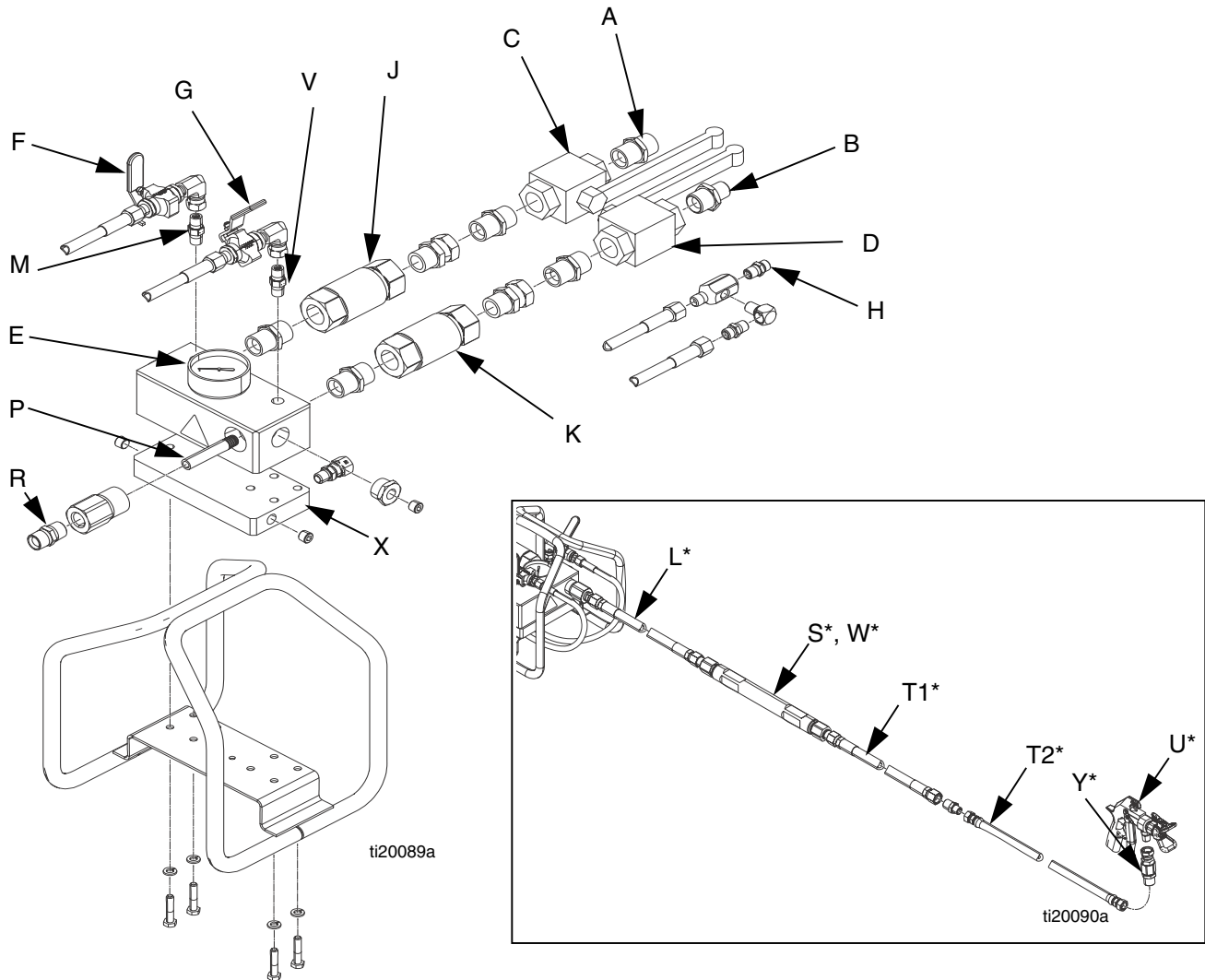

FIG. 1: Typical Installation

Key:

- | | | | |
|---|--|----|--|
| A | A (Resin) Supply Inlet, 3/4 npt(m) | M | A (Resin) Solvent Check |
| B | B (Hardener) Supply Inlet, 1/2 npt (m) | P | B (Hardener) Injector (not visible; inside outlet R) |
| C | A (Resin) Ball Valve and Shutoff Handle | R | Mix Manifold Outlet, 1/2 x 1/2 male |
| D | B (Hardener) Ball Valve and Shutoff Handle | S | *Static Mixer Housing |
| E | Fluid Pressure Gauge | T1 | *Mix Hose |
| F | A (Resin) Solvent Inlet Valve, 1/4 npt(m) | T2 | *Fluid Whip Hose |
| G | B (Hardener) Solvent Inlet Valve | U | *Airless Spray Gun |
| H | Main Solvent Inlet | V | B (Hardener) Solvent Check |
| J | A (Resin) Check Valve | W | *Static Mixing Element (not visible; inside tube S) |
| K | B (Hardener) Check Valve | X | Heated Water Circulation Plate |
| L | *Integrator Hose | Y | *Swivel Accessory 207946 |

* Not included in mix manifold kit.

Overview

The left side of the mix manifold is intended for the major volume material, or the higher viscosity material if using a 1:1 volume mix. This side is referred to throughout the manual as the resin side or “A” side. The right side is referred to as the hardener side or “B” side.

See FIG. 2 to view flow of A and B material inside the XM PFP Mix Manifold.

The resin and hardener enter the manifold through the manifold inlet ports. The A material flows through the manifold to the material outlet port. The injector tube creates a hollow stream of A material for the B material to combine with once the hardener exits the injector (P). The resin and hardener materials enter the mix manifold outlet (R) before the materials enter the first length of integrator fluid hose (L). The materials then pass through the mixer assembly (S) where they are thoroughly mixed. Then they pass through a length of mix hose (T1) where they continue to be lightly mixed before entering the fluid whip hose (T2) then the gun (U).

Follow these recommendations for setup (see FIG. 1 on page 6):

- Use at least a 1/2 in. (12 mm) x 2 ft (0.6 m) integrator hose (L) connected to the mix manifold outlet
- Use at least 12 elements in the static mixer after the integration hose and before the mix hose (T1).
- Use at least a 1/2 in. (12 mm) x 10 ft (3.0 m) mix hose (T1) after the static mixer and before the spray gun.

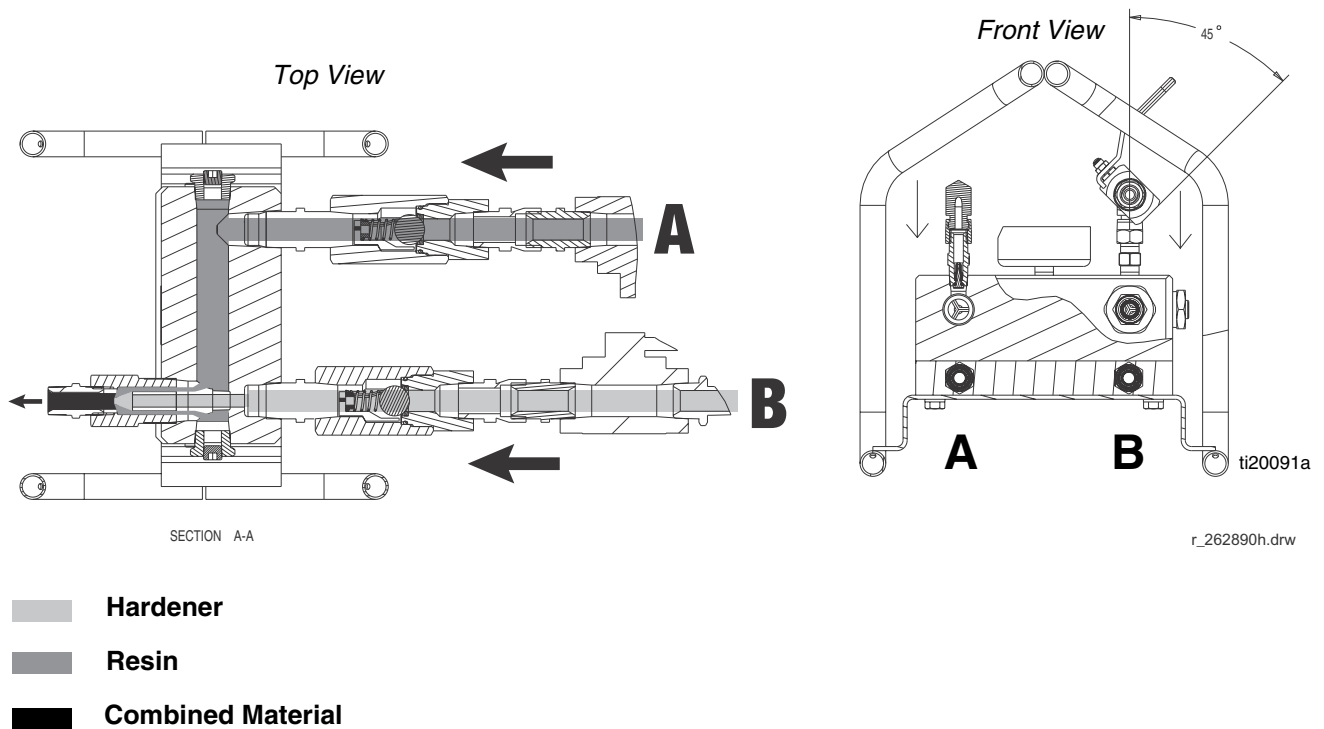

FIG. 2: Cutaway View

Installation



The mix manifold is designed for use on proportioning pumps with independent drive motors. Do not use this manifold on a mechanically linked sprayer without using mechanically linked on/off A and B valves as this will result in fluid pressures that can rupture equipment and cause skin injection.

For assistance in setting up a plural component sprayer, contact your Graco distributor, to ensure that you select the proper type and size equipment for your system.

Fluid Inlets

See FIG. 1 on page 6. The A and B fluid inlets are equipped with 3/4 in. check valves, ball valves, and 3/4 in. x 3/4 in. npt fittings and 3/4 in. x 1/2 in. fitting. Connect 3/4 in. and 1/2 in. npsm(f) fluid hoses using the two adapter nipples.

Solvent Inlet

See FIG. 1 on page 6. Connect the solvent supply line from the solvent pump to the 1/4 npt(m) solvent inlet valve (H). Use a grounded, Graco-approved hose rated to withstand the maximum fluid working pressure of the solvent pump. The solvent chosen must be chemically compatible with the hose core material.

Fluid Outlet

See FIG. 1 on page 6. Connect the 1/2 in. ID x 2 ft. (minimum) integrator hose (L) to the mix manifold fluid outlet (R). Then connect the static mixer (S) and mix hose (T1) to the 1/2 npt(f) integrator hose (L). Then connect the fluid whip hose (T2) to the mix hose and the gun to the whip hose.



Heated Manifold

See FIG. 1 on page 6. The XM PFP manifold has a 1 in. thick aluminum plate with brass compression fittings for 1/2 in. OD x 3/8 in. ID nylon hose used to circulate heated water/glycol and heat the mix manifold.

Mounting

To mount the bare manifold, drill four holes in the mounting surface, and secure with four 5/16-18 x 1/2 in. (50 mm long) screws. Use the manifold as a template when drilling the holes.

Grounding

						
<p>The equipment must be grounded to reduce the risk of static sparking. Static sparking can cause fumes to ignite or explode. Grounding provides an escape wire for the electric current.</p>						

- **Pump:** use a ground wire and clamp as instructed in your XM PFP sprayer operation manual.
- **Air and fluid hoses:** use only electrically conductive hoses with a maximum of 500 ft (150 m) combined hose length to ensure grounding continuity. Check electrical resistance of hoses. If total resistance to ground exceeds 29 megohms, replace hose immediately.
- **Mix manifold and solvent flush system:** use only a Graco approved grounded solvent hose. Not all heated hoses are grounded, and the mix manifold primary ground is through the solvent hose. Ensure that the solvent pump is properly grounded, as instructed in your solvent pump manual. Ensure there is electrical continuity from the spray tip to the grounded solvent hose.
- **Air compressor:** Follow manufacturer's recommendations.
- **Spray gun:** ground through connection to a properly grounded fluid hose and pump.
- **Fluid supply container:** follow local code.
- **Object being sprayed:** follow local code.
- **Solvent pails used when flushing:** follow local code. Use only conductive metal pails, placed on a grounded surface. Do not place the pail on a non-conductive surface, such as paper or cardboard, which interrupts grounding continuity.
- **To maintain grounding continuity when flushing or relieving pressure:** hold metal part of the spray gun firmly to the side of a grounded metal pail, then trigger the gun.

Flush Before Using Equipment

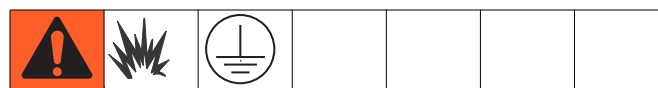

The equipment was tested with lightweight oil, which is left in the fluid passages to protect parts. To avoid contaminating your fluid with oil, flush the equipment with a compatible solvent before using the equipment. See **Flush**, page 11.

Operation

Pressure Relief Procedure



Follow the Pressure Relief Procedure whenever you see this symbol.



This equipment stays pressurized until pressure is manually relieved. To help prevent serious injury from pressurized fluid, such as skin injection, splashing fluid and moving parts, follow the Pressure Relief Procedure when you stop spraying and before cleaning, checking, or servicing the equipment.

Relieve A and B Fluid Pressure

1. Engage trigger lock.

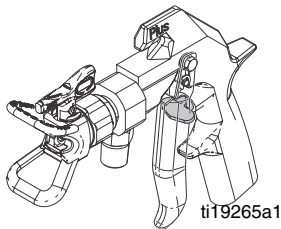

2. Press Stop  to turn sprayer OFF.
3. Close all air motor supply valves or any source of fluid pressure.
4. If fluid heaters are used, shut them off using the controls on the display module.
5. Shut off RAM air supply.

6. Disengage trigger lock.

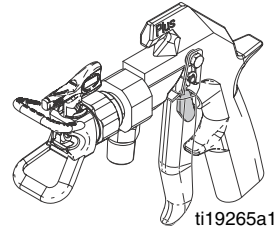

7. Hold a metal part of the gun firmly to a grounded metal pail with a splash guard in place. Trigger gun to relieve pressure in material hoses.

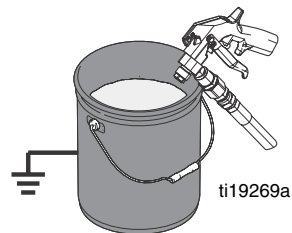

8. Engage trigger lock.
9. Close the mix manifold inlet ball valves (C, D).
10. Flush mixed material hoses, mixer, and gun. See **Flush** on page 11.

Flush



The equipment must be grounded to reduce the risk of static sparking. Static sparking can cause fumes to ignite or explode. Grounding provides an escape wire for the electric current.

If your system uses heaters, shut off the main power to the heaters and heated hose control and allow to cool before flushing.

NOTICE
To prevent fluid from curing in the equipment, flush the system frequently. Be sure there is an adequate supply of flushing fluid before spraying.

NOTE:

- Ensure the chosen flushing fluid is compatible with dispense fluid and the equipment wetted parts.
- Solvent may channel through viscous fluids and leave a coating of mixed fluid on the inner tube of your hose. Be sure all fluid is thoroughly flushed from the hose after each use.
- Remove spray tip for more thorough cleaning of the whip hose and static mixers.
- Use heated water or choose a solvent that dissolves the material you are mixing.
- Always leave equipment filled with fluid to avoid drying and scaling.

1. Relieve pressure; see page 10.
2. Engage trigger lock. Remove spray tip and trigger guard assembly.

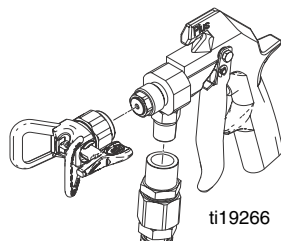
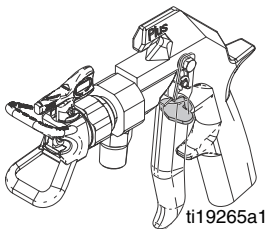

3. Close mix manifold inlet ball valves.

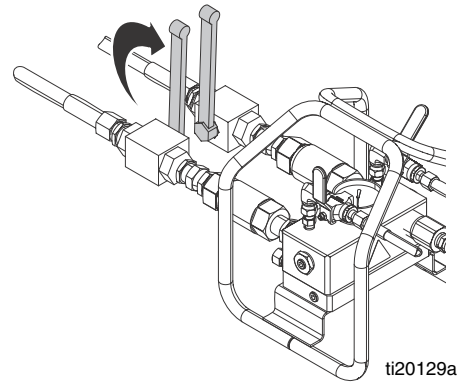

4. Open solvent inlet valves.

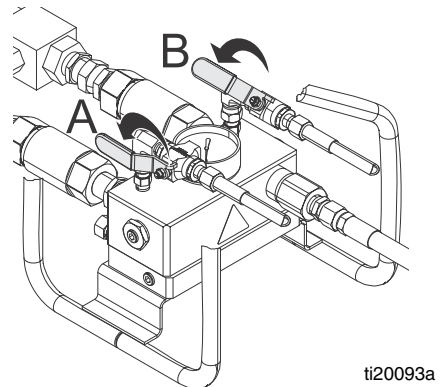

5. Turn on solvent flush pump.
6. Disengage spray gun trigger lock.

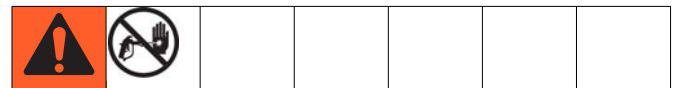
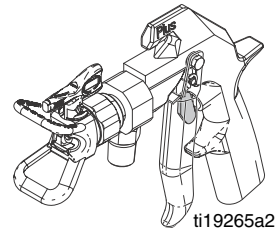

7. Trigger gun into a grounded metal pail with lid. Use a lid with a hole to dispense through to avoid splashing.

Operation

8. Cycle the solvent flush ball valves on and off independently several times to be sure both sides are thoroughly flushed. Continue flushing until clean solvent dispenses.

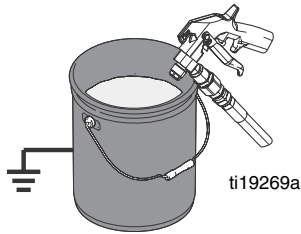

9. Turn off solvent pump air supply.
10. Hold the metal part of the gun firmly to a grounded metal pail with lid in place. Trigger gun until all fluid pressure is relieved.
11. Engage trigger lock.
12. Close solvent inlet valves.

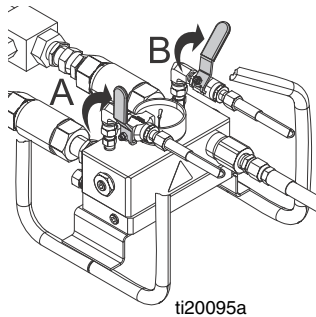

Dispensing and Spraying

1. Close solvent inlet valves.

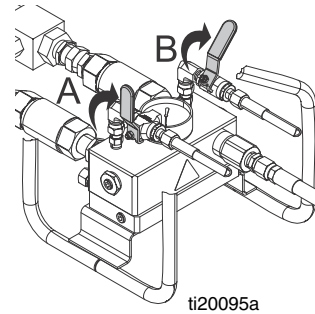

2. Open mix manifold inlet ball valves.

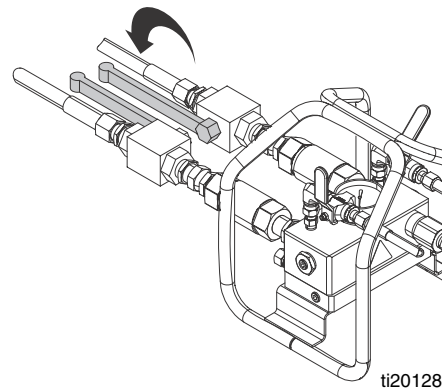

3. Ensure sprayer is in "spray" mode and push the green START button.
4. Disengage spray gun trigger lock.

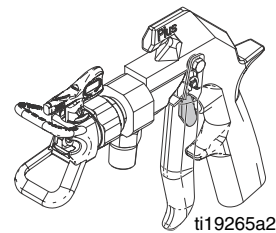

5. Hold the metal part of the gun firmly to a grounded metal pail with a lid to avoid splashing. Trigger the gun until mixed coating material is evident and flushing fluid is gone.
6. Proceed to spraying.

Volume Balancing the Mix Manifold

Ratio errors can occur between the sprayer and the mix manifold even when the sprayer output ratio is accurate.

The following can occur when the hoses are not volume balanced to the mix ratio:

- Hoses fill to high pressure while metering on-ratio.
- Only the A material hose rises to spray pressure.
- Off-ratio at the mix point until hose pressures equalize.

Lead/Lag Imbalance

When resin and hardener volume requirements (ratio) and/or viscosities are different an imbalance can occur each time the gun is triggered. This occurs because the fluids can rush out of the manifold near a 1:1 ratio before the sprayer starts.

To avoid this imbalance:

- Pressurize hoses to spray pressure before starting spray mode.
- Size the fluid delivery hose volume to nearly match the mix ratio. See Table 1.

Hose Selection

Hoses should be sized to match the hose volume ratio to the mix ratio. The hose size should also allow for minimum pressure drop on the major volume side to meet your flow requirements.

Use Table 1 to match mix ratio, hose selection, and volume ratio. Use Table 2 on page 14 to reference amount of pressure drop for 50 ft lengths of different hose sizes.

Size hoses to:

- Minimize pressure drop on the high volume and often higher viscosity resin side to achieve higher flow and pressure at the gun while spraying.
- Allow both A and B material hoses to come up to spray pressure together when A and B fluids are metered into the hoses on ratio.
- Balance the inherent stall pressure between the resin A and hardener B sides when the gun closes and also when triggered. This reduces the lead/lag error at the mix point when the spray gun is triggered.

Table 1: Volume Ratio of A to B Hose

Mix Ratio	Hose Selection A x B	Hose Volume Ratio
1:1	3/4 x 3/4	1.00:1
	1/2 x 1/2	
	3/8 x 3/8	
2:1	3/4 x 1/2	2.25:1
	1/2 x 3/8	1.78:1
	3/8 x 1/4	2.25:1
3:1	3/4 x 1/2	2.25:1
	3/8 x 1/4	2.25:1
4:1 to 6:1	1/2 x 1/4	4.00:1
4:1 to 8:1	3/4 x 3/8	4.00:1
6:1 to 10:1	1/2 x 3/16	7.00:1
8:1 to 10:1	3/4 x 1/4	8.80:1

Example: At a 4:1 mix ratio, a 1/2 in. ID resin hose and a 1/4 in. ID hardener hose matches the 4:1 volume ratio.

Table 2: Hose Selection by Pressure Drop

Hose ID (in.)	Pressure drop in psi (per 50 ft section per 1,000 cps at 1 gal/min.)	Pressure Drop in bar (per 15.24 meter section per 1,000 cps at 1 liter/min.)
1/8	55,910	1,018
3/16	11,044	201
1/4	3,494	64
3/8	690	13
1/2	218	4
5/8	89	1.62
3/4	43	0.78

Reference Formula

Total Pressure Drop = P x V x L x F

Key:

P= Pressure drop from chart

V = Viscosity in centipoise /1000

L= Length of hose in feet / 50

F= Flow rate in gallons per minute

Example #1: What is the pressure loss of a 2,000 cps material through 150 ft of 3/8 in. ID hose at 0.75 gpm?

690 psi (from chart) x 2 (2,000 cps /1,000) x 3 (150 ft / 50) x 0.75 (gpm) = 3105 psi loss

Example #2: What is the pressure loss of a 2,000 cps material through 150 ft of 1/2 in. ID hose at 0.75 gpm?

218 psi (from chart) x 2 (2,000 cps /1,000) x 3 (150 ft / 50) x 0.75 (gpm) = 981 psi loss

This is a lot of pressure loss before reaching the spray gun. Continue to **Example #2** which examines the same situation but with a 1/2 in. ID hose.

Maintenance

Clean Static Mixers

See FIG. 1, page 6. One 12 element mixer is attached (S, Part No. 262478) to the integrator hose (L). This housing uses mix elements, available in a package of 25 (W, Part No. 248927).

NOTICE

Never use a swivel union on the mixer inlets. The union will compress the tube and make it impossible to remove the mix element.

Clean Mix Manifold Outlet

1. Remove outlet fitting (33) to expose B center injection tube (9).

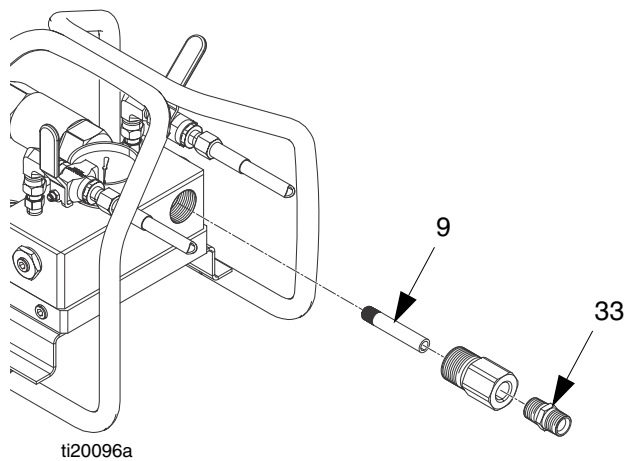

2. Clean any build-up on, around, or inside the tube (9).
3. Reinstall outlet fitting (33).

Troubleshooting



1. Relieve the pressure before you check or service any system equipment.
2. Check all possible causes and solutions in the troubleshooting chart before disassembling the manifold.

Problem	Cause	Solution
Little or no resin output.	Fluid inlet is plugged.	Clean inlet; remove obstruction. See Clean Mix Manifold Outlet , page 15.
	Fluid container is empty.	Refill.
Little or no hardener output.	Fluid inlet is plugged.	Clean inlet; remove obstruction. See Clean Mix Manifold Outlet , page 15.
	Fluid container is empty.	Refill.
Mixed fluid will not flush out.	Fluid is hardened in static mixers or whip hose.	Clean with compatible solvent. See Maintenance , page 15. Replace as necessary.
	Solvent supply container is empty.	Refill.
	Solvent is not compatible with fluid.	Change to compatible solvent.
Hardener pressure higher than normal.	Hardener is cold.	Correct heat problem. See fluid heater section of XM PFP Plural-Component Sprayer Repair manual 3A2989.
Hardener pressure lower than normal.	Resin is cold. Flow rate is low.	Correct heat problem. See fluid heater section of XM PFP Plural-Component Sprayer Repair manual 3A2989.
Spray pattern developing tails.	Static mixer and/or whip hose plugging up.	Replace restrictor.
		Clean Static Mixers , page 15.
		Clean spray gun and tip. See gun manual.
	Low pressure from sprayer.	Check air supply pressure. Check inlet air gauges while spraying.
	Cold material.	Increase heat. See XM PFP Plural-Component Sprayer Operation manual 3A2776.
Too much pressure drop.	Use larger hoses or more heat.	
Resin or hardener does not shut off.	Damaged ball or seat or seal in valve (52).	Replace or rebuild valve.
Off ratio condition after increasing spray pressure in spray mode with a remote mix manifold.	Hoses not volume balanced.	Volume balance A and B closer to volume mix ratio. See Volume Balancing the Mix Manifold , page 13.

Repair



Follow **Pressure Relief Procedure**, page 10, when you stop spraying and before cleaning, checking, servicing, or transporting equipment. Read warnings in your sprayer manual.

NOTICE

- Be sure to label all fluid parts A or B when disassembling them. Doing so prevents interchanging resin and hardener parts during reassembly, which will contaminate the materials and the fluid path through the equipment.
- Color-coded chemically resistant tape may be used to label the parts. Use blue for resin and green for hardener.

Check Valves

When replacing material check valves or solvent check valves, reinstall with proper flow direction.

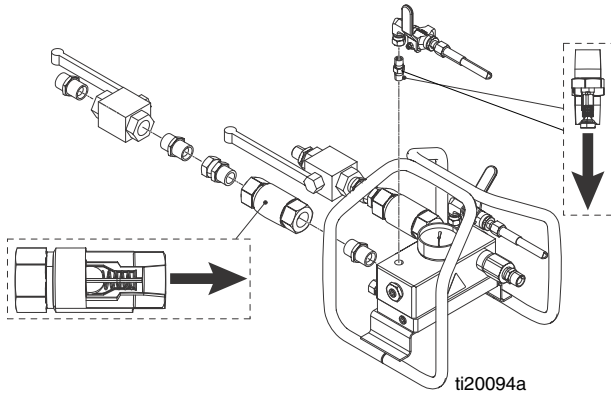

Parts

262890 Mix Manifold

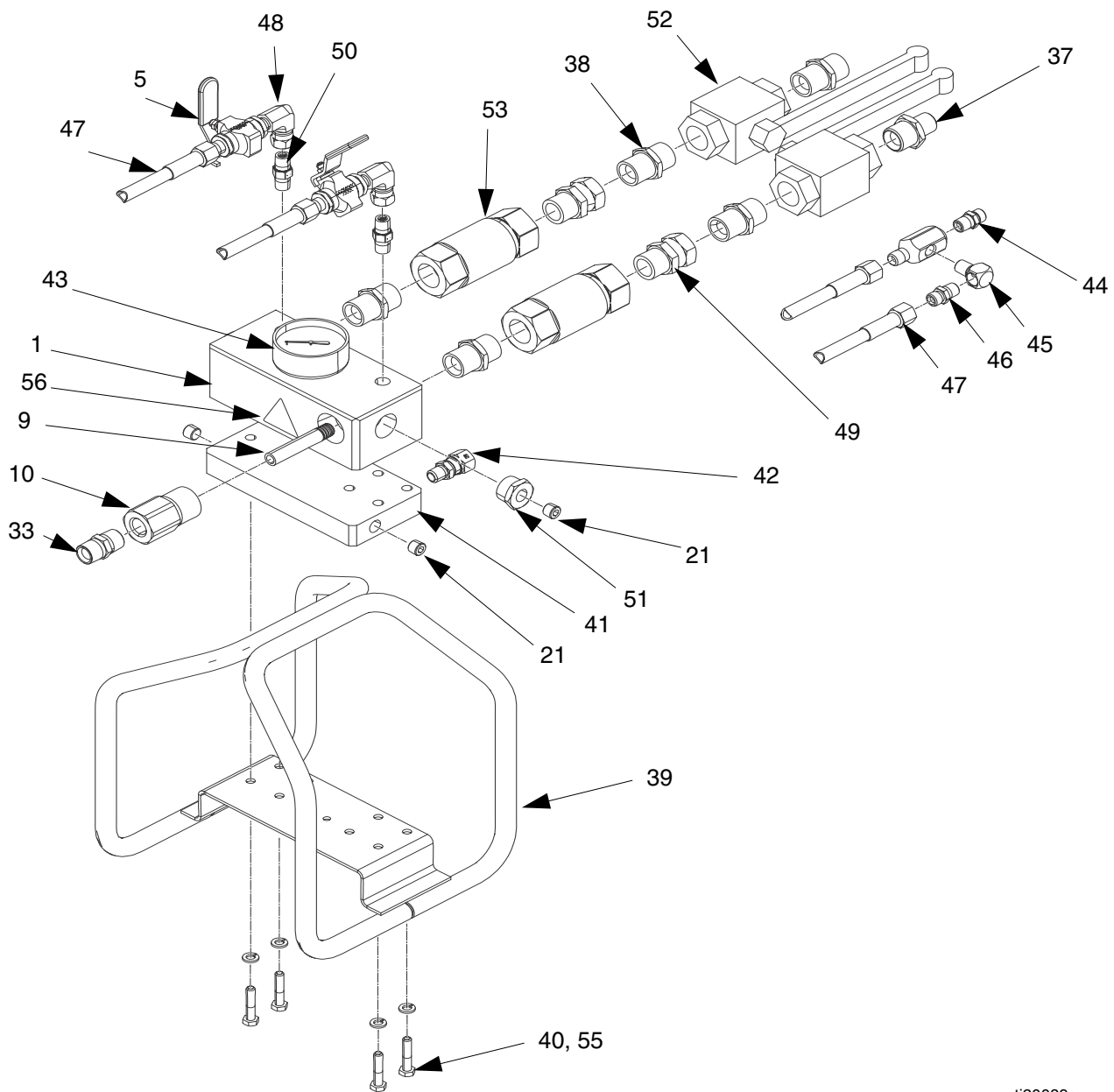

ti20089a

NOTE: Apply pipe sealant to all non-swiveling threads.

262890 Mix Manifold

Ref	Part	Description	Qty
1	16T870	BLOCK, manifold	1
5	239018	VALVE, ball, stainless steel	2
9	126790	TUBE, injector, 1/4 npt	1
10	15R067	PIPE, outlet, mixer manifold	1
21	100721	PLUG, pipe	4
25	---	LUBRICANT, thread	1
26	---	SEALANT, pipe, stainless steel	1
33	158491	FITTING, nipple	1
37	157191	FITTING, adapter (1/2 npt x 3/4 npt)	1
38	160032	FITTING, nipple	5
39	262522	CARRIAGE, remote manifold	1
40	102547	SCREW, cap, hex head	4
41	16T294	PLATE, heater transfer	1
42	126692	FITTING, tube, npt x tube	2
43	114434	GAUGE, pressure, fluid, stainless steel	1
44	15R875	FITTING, tee, 1/4 male x female x female	1
45	100840	FITTING, elbow, street	1
46	162453	FITTING, (1/4 npsm x 1/4 npt)	2
47	H42503	HOSE, coupled, 4500 psi, 0.25 ID, 3 ft	2
48	157676	FITTING, union swivel, 90 degree	2
49	157785	FITTING, swivel	2
50	501867	VALVE, check	2
51	C19681	BUSHING, pipe	2
52	126725	VALVE, ball, 3/4, 6000 psi	2
53	16T481	VALVE, check	2
53a	102595	O-RING	1
55	189285	WASHER, lock, spring	1
56▲	189285	LABEL, hot surface	1

--- Not for sale.

▲ Replacement Danger and Warning labels, tags and cards are available at no cost.

Technical Data

Maximum working pressure . . .	6000 psi (41 MPa, 414 bar) for A and B materials 4500 psi (31 MPa, 310 bar) for flushing fluid 100 psi (0.7 MPa, 7 bar) for heating fluid
Maximum fluid temperature . . .	180°F (82°C)
Fluid inlet	3/4 in. npt and 3/4 in. x 1/2 in. nipple fittings for 3/4 in. x 1/2 in. hoses
Fluid outlet size	1/2 in. npt(m) nipple
Solvent inlet valves	1/4 in. npt(m)
Heated fluid ports	1/4 in. npt(f)
Wetted parts	<i>Manifold block and internal parts:</i> PTFE, electroless nickel plated steel, zinc plated steel <i>Flush valves and fittings:</i> stainless steel, plated carbon steel, hardened alloy steel, acetal, PTFE <i>Fluid ball valves:</i> plated carbon steel, acetal, PTFE, FKM <i>Fluid check valves:</i> plated carbon steel, carbide seat, PTFE, alloy steel ball

Graco Standard Warranty

Graco warrants all equipment referenced in this document which is manufactured by Graco and bearing its name to be free from defects in material and workmanship on the date of sale to the original purchaser for use. With the exception of any special, extended, or limited warranty published by Graco, Graco will, for a period of twelve months from the date of sale, repair or replace any part of the equipment determined by Graco to be defective. This warranty applies only when the equipment is installed, operated and maintained in accordance with Graco's written recommendations.

This warranty does not cover, and Graco shall not be liable for general wear and tear, or any malfunction, damage or wear caused by faulty installation, misapplication, abrasion, corrosion, inadequate or improper maintenance, negligence, accident, tampering, or substitution of non-Graco component parts. Nor shall Graco be liable for malfunction, damage or wear caused by the incompatibility of Graco equipment with structures, accessories, equipment or materials not supplied by Graco, or the improper design, manufacture, installation, operation or maintenance of structures, accessories, equipment or materials not supplied by Graco.

This warranty is conditioned upon the prepaid return of the equipment claimed to be defective to an authorized Graco distributor for verification of the claimed defect. If the claimed defect is verified, Graco will repair or replace free of charge any defective parts. The equipment will be returned to the original purchaser transportation prepaid. If inspection of the equipment does not disclose any defect in material or workmanship, repairs will be made at a reasonable charge, which charges may include the costs of parts, labor, and transportation.

THIS WARRANTY IS EXCLUSIVE, AND IS IN LIEU OF ANY OTHER WARRANTIES, EXPRESS OR IMPLIED, INCLUDING BUT NOT LIMITED TO WARRANTY OF MERCHANTABILITY OR WARRANTY OF FITNESS FOR A PARTICULAR PURPOSE.

Graco's sole obligation and buyer's sole remedy for any breach of warranty shall be as set forth above. The buyer agrees that no other remedy (including, but not limited to, incidental or consequential damages for lost profits, lost sales, injury to person or property, or any other incidental or consequential loss) shall be available. Any action for breach of warranty must be brought within two (2) years of the date of sale.

GRACO MAKES NO WARRANTY, AND DISCLAIMS ALL IMPLIED WARRANTIES OF MERCHANTABILITY AND FITNESS FOR A PARTICULAR PURPOSE, IN CONNECTION WITH ACCESSORIES, EQUIPMENT, MATERIALS OR COMPONENTS SOLD BUT NOT MANUFACTURED BY GRACO. These items sold, but not manufactured by Graco (such as electric motors, switches, hose, etc.), are subject to the warranty, if any, of their manufacturer. Graco will provide purchaser with reasonable assistance in making any claim for breach of these warranties.

In no event will Graco be liable for indirect, incidental, special or consequential damages resulting from Graco supplying equipment hereunder, or the furnishing, performance, or use of any products or other goods sold hereto, whether due to a breach of contract, breach of warranty, the negligence of Graco, or otherwise.

FOR GRACO CANADA CUSTOMERS

The Parties acknowledge that they have required that the present document, as well as all documents, notices and legal proceedings entered into, given or instituted pursuant hereto or relating directly or indirectly hereto, be drawn up in English. Les parties reconnaissent avoir convenu que la rédaction du présente document sera en Anglais, ainsi que tous documents, avis et procédures judiciaires exécutés, donnés ou intentés, à la suite de ou en rapport, directement ou indirectement, avec les procédures concernées.

Graco Information

For the latest information about Graco products, visit www.graco.com.

TO PLACE AN ORDER, contact your Graco distributor or call to identify the nearest distributor.

Phone: 612-623-6921 **or Toll Free:** 1-800-328-0211 **Fax:** 612-378-3505

*All written and visual data contained in this document reflects the latest product information available at the time of publication.
Graco reserves the right to make changes at any time without notice.*

For patent information, see www.graco.com/patents.

Original instructions. This manual contains English. MM 3A2988

Graco Headquarters: Minneapolis

International Offices: Belgium, China, Japan, Korea

GRACO INC. AND SUBSIDIARIES • P.O. BOX 1441 • MINNEAPOLIS MN 55440-1441 • USA
Copyright 2012, Graco Inc. All Graco manufacturing locations are registered to ISO 9001.

www.graco.com
Revised February 2013