

K-20

Aircraft Camera

18-C-174

Instructions for

Operation *and* Overhaul

*

The Folmer Graflex Corporation
Rochester, New York, U. S. A.

TABLE OF CONTENTS

Section	Page	Section	Page
I Introduction	5	VI Inspection, Maintenance and Lubrication	17
II General Description	5	1. Inspection and Maintenance	17
III Detailed Description	5	<i>a.</i> General	17
1. General	5	<i>b.</i> Cleaning	17
2. Camera Body	7	<i>d.</i> Removing the Shutter	17
3. Lens and Shutter	7	<i>e.</i> Replacing the Shutter	19
4. Film-Transport Mechanism	7	<i>f.</i> Timing the Shutter	19
5. Vacuum Back	8	2. Lubrication	20
6. Operating Handle	9	<i>a.</i> General	20
7. Exposure Counter	10	<i>b.</i> Shutter	20
8. Recorder	10	<i>c.</i> Camera Body	21
9. Viewfinder	10	VII Disassembly, Inspection, Repair, Reassembly and Final Test	22
10. Accessories	10	1. Disassembly	22
<i>a.</i> Film-Loading Guide	10	2. Inspection	22
<i>b.</i> K-20 Film Spools	10	3. Repair	22
<i>c.</i> Lens Cap	10	4. Reassembly	22
<i>d.</i> Filters	10	<i>a.</i> General	22
<i>e.</i> Wall Bracket	11	<i>b.</i> Mechanism Assembly (K20D-H2)	25
<i>f.</i> Carrying Case	11	(1) Side Plate Assembly (K20D-H3)	25
11. Exposure Counter	12	(2) Operating Handle Assembly (K20C-H10)	26
IV Preparation for Use	13	(3) Take-Up Spool Ratchet Assembly (K20B-H6)	27
1. General	13	(4) Mechanism Rear Plate Assembly (K20C-H16)	27
2. Opening and Closing the Camera	13	(5) Vacuum Back Assembly (K20C-H22)	28
3. Loading the Camera	13	(6) Cone Assembly (K20D-H25)	30
4. Inserting the Recorder	14	<i>c.</i> Shutter Assembly (K20E-F1)	30
5. Opening and Closing the Viewfinder	14	5. Final Test	33
V Operation	15	VIII Replacement Parts List	34
1. General	15		
2. Setting Lens and Shutter	15		
3. Checking the Exposure Counter	15		
4. Holding the Camera	15		
5. Making Pictures	15		
6. Unloading	16		
7. Storage	16		

ILLUSTRATIONS

Figure	Page
1 Complete K-20 Outfit	4
2 Camera with Cover and Recorder Removed	6
3 Interior Mechanism	8
4 Shutter, Lens, Lens Cap, Recorder, Filters and Wall Bracket	9
5 Complete Outfit in Case	11
6 Method of Loading Film	12
7 Holding the K-20 Camera	16
8 Shutter—Rear View	18
9 Camera Body—Interior View	18
10 Lubrication—Interior of Shutter	20
11 Lubrication—Leaf Center	21
12 Setting the Angle of the Pin	23
13 Mechanism Assembly	26
14 Vacuum Back Assembly	29
15 Shutter Case—Interior View	31
Table of Index Numbers	36



Figure 1—Complete K-20 Outfit

SECTION I

INTRODUCTION

1. The K-20 Aircraft Camera is identified by the Navy Stock Number 18-C-174.
2. The K-20 Aircraft Camera accepts aerial film identified by the following Navy Stock Numbers:
 - 9-foot lengths: 18-F-31500 (Special Reconnaissance Type)
 - 18½-foot lengths: 18-F-31502 (Special Reconnaissance Type)
 - 9-foot lengths: 18-F-31543 (Tri-X Pan)
 - 18½-foot lengths: 18-F-31546 (Tri-X Pan)
 - 18½-foot lengths: 18-F-31525 (Super-XX Pan)

SECTION II

GENERAL DESCRIPTION

1. The Type K-20 Aircraft Camera (*figure 1*) is a hand-held, manually-operated camera designed for making oblique spotting photographs from standard military aircraft.
2. The K-20 camera makes 50 negatives (4 x 5 inches) on a roll of special K-20 film. The shutter-release and film-transport mechanisms are interlocked to prevent double exposures and skipped frames, and have their controls located in the right (operating) handle of the camera. A vacuum back and pressure plate keep the film flat during exposure.
3. The lens of the K-20 camera is a prefocused 161 mm (6⅞ inches) f/4.5, set in a removable intra-lens shutter mounted in the metal cone that forms the front of the camera.
4. An oblique viewfinder, an exposure counter, a data-recording device, a film-loading guide, and a wall bracket for securing the camera to the fuselage of the plane when it is not in use, are provided. Two bayonet-mount filters (red and minus-blue), a lens cap, a film spool, and a fibre carrying case, are also provided.
5. The K-20 camera is made of metal (largely aluminum alloys). It weighs 11¾ pounds loaded, and its maximum overall outside dimensions are 9½ inches x 7½ inches x 11 inches.

SECTION III

DETAILED DESCRIPTION

1. General.

a. The Type K-20 Aircraft Camera combines, in one unit, all of the major components of an aerial camera: body, lens, shutter, magazine, film-transport mechanism, vacuum back, operating controls, exposure counter, recording device, viewfinder, and means for attachment to the fuselage when not in use.

b. The references "right," "left," "top," "bottom" etc., in this Handbook are based on the camera being held in operating position (*figure 7*).

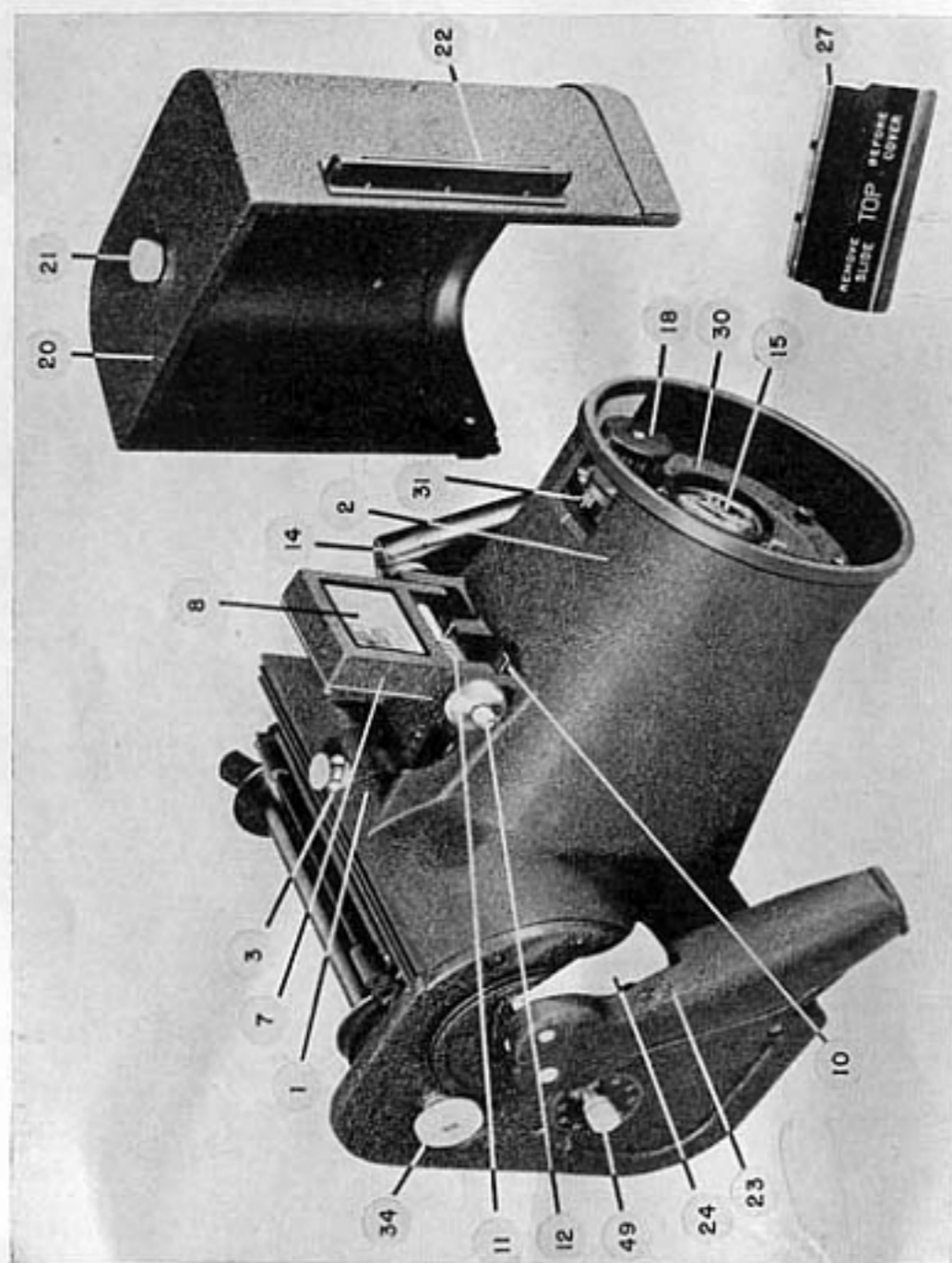

Figure 2—Camera With Cover and Recorder Removed

2. Camera Body.

The camera body is of cast aluminum alloy. The forepart, containing the lens and shutter, is the cone (2) to which are attached the (left) fixed handle (14), the wind- and trip-coupling shafts, and the viewfinder. The afterpart of the body (1) contains the film-transport, vacuum system, shutter-setting, and other mechanisms; the operating handle (23) and trigger (24) are attached to its right side. This afterpart of the body is inclosed in the removable magazine cover (20) (figure 2.)

3. Lens and Shutter.

a. The lens (15) and shutter (30) are mounted in the cone (2), and the dials (18) and (31) with which they are set are accessible through ports near the nose of the cone. The lens is a 161 mm ($6\frac{3}{8}$ inches) $f/4.5$, (Kodak Anastigmat or Ilex Paragon) focused for objects at infinity, with a diaphragm scaled in the standard system of relative apertures from $f/4.5$ to $f/22$. The front cell of the lens has a diameter of 44.5 mm ($1\frac{3}{4}$ inches) and will accept filters in special bayonet mounts. When the camera is not in use, the lens is protected by the lens cap (19). The cone extends sufficiently beyond the lens to protect the shutter, lens, and an attached filter from damage when the camera is placed nose down on a flat surface. (See figures 2 and 4.)

b. The special shutter (30) (figure 4) in which the lens is mounted, operates at speeds of 1/500, 1/250, and 1/125 second. The movements for cocking and releasing it are transmitted from the operating handle (23) (figure 2) by coupling shafts, inside the cone, that connect with the shutter from the rear.

c. The diaphragm and shutter-speed controls are accessible through ports in the upper forward section of the cone.

d. The scale of the diaphragm-control knob carries white numbers as follows: $f/4.5$ - 5.6 - 8 - 11 - 16 - 22 to indicate the relative apertures. This knob may be rotated in either direction over the range of the markings. Bring the desired $f/$ number under the reference line scribed in the cone at the edge of the opening through which the scale is visible. Do not try to force this knob beyond the stops at the end of its rotation.

e. The scale of the retard knob (shutter-speed control) is marked 125-250-500 to indicate exposure times of 1/125, 1/250, and 1/500 second respectively. Intermediate settings will not give intermediate speeds. The knob may be rotated freely in either direction over the entire scale, but no attempt should be made to force it past the stop between 125 and 500.

4. Film Transport Mechanism.

The film transport mechanism (figure 3) is a system of cams, gears, and levers housed in the afterpart of the body. Film $5\frac{1}{4}$ inches wide (in rolls approximately 20 feet long, with 4-foot leader of opaque film and 4-foot paper trailer), feeds from a supply spool across the picture aperture and is wound up on the take-up spool. Each cycle of the operating handle (23) (figure 2) advances the film about $4\frac{1}{2}$ inches, making 50 negatives (4×5 inches) per roll with a nominal interval of $\frac{1}{2}$ inch between negatives. A special device disengages the film transport when each $4\frac{1}{2}$ inches of film have passed through the metering mechanism.

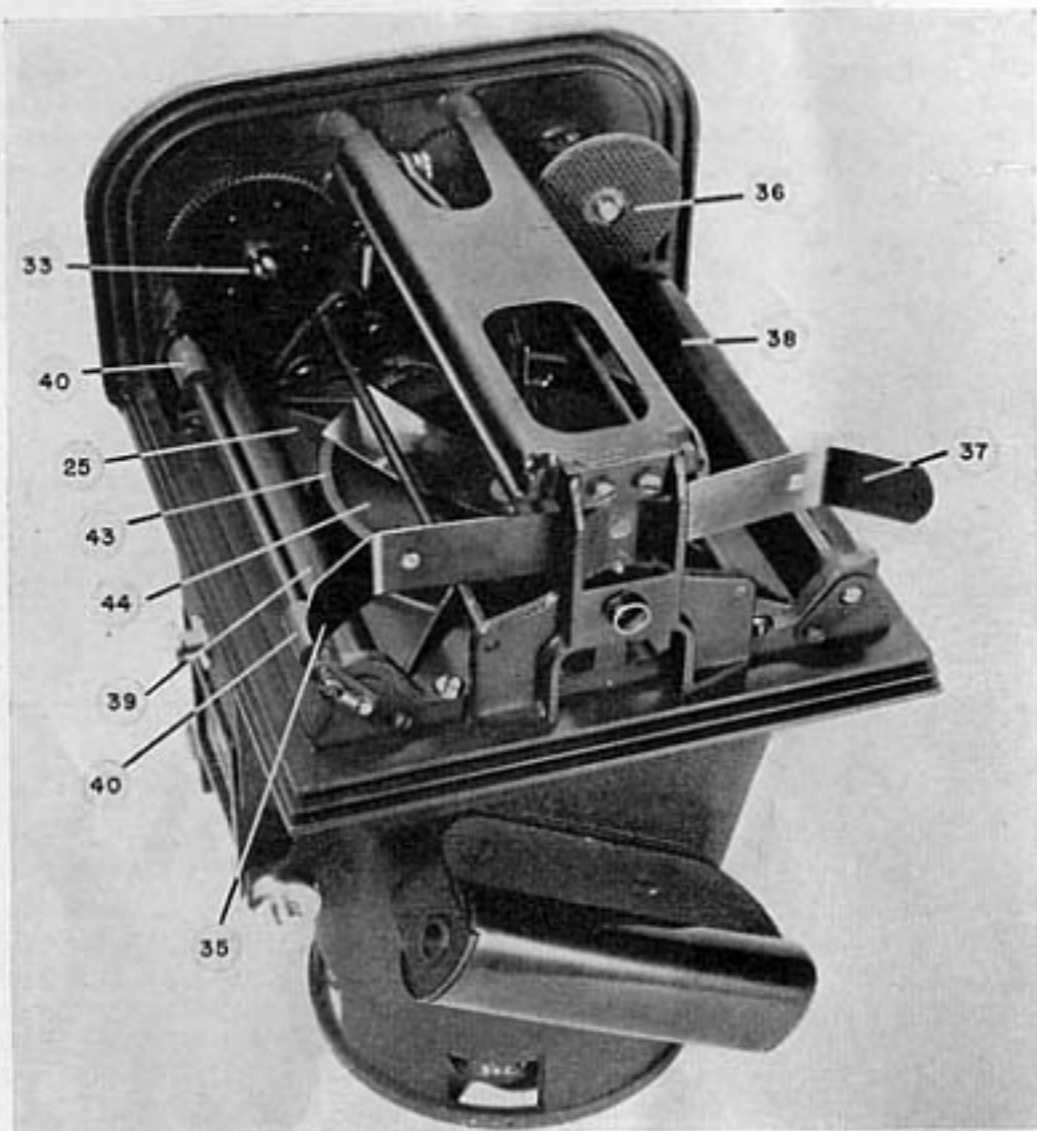

Figure 3—Interior Mechanism

5. Vacuum Back.

The vacuum back (43) (figure 3) consists of a retractable pressure plate (25) and a vacuum piston (44), whose movements are synchronized with the film transport and shutter release. Its function is to keep the film flat and in the focal plane during the exposure.

6. Operating Handle.

a. The operating handle (23) (figure 2) on the right side of the camera is pivoted near its upper end, and one cycle of rotating it forward and back performs all the operations necessary to prepare the loaded camera for an exposure. Pressure on the trigger (24), located under the index finger in the upper forward side of the operating handle, makes the exposure.

b. When the operating handle is rotated fully forward, the film is advanced $4\frac{1}{2}$ inches and the exposure counter (49) advances by one number. Rotating the handle back to its original position lowers the pressure plate (25) against the film, sets the vacuum piston (44), cocks the shutter (30), and locks the film transport mechanism. (See figures 2 and 3.)

c. Pressure on the trigger (24) releases the vacuum piston (44) so that the film is drawn back flat against the pressure plate; starts the mechanism which trips the shutter to make the exposure; and lastly releases the pressure plate so that it withdraws from the film and leaves it free to advance during the next cycle.

d. The shutter cannot be tripped until the film is advanced, and the film cannot be advanced until the shutter has been tripped.

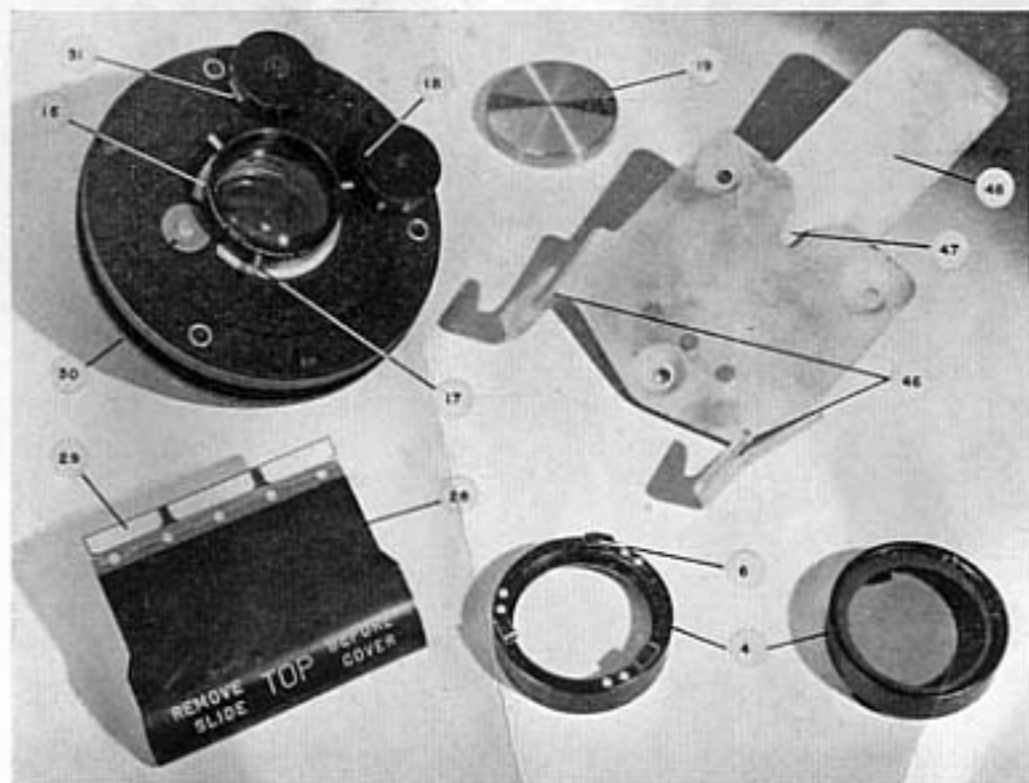

Figure 4—Shutter, Lens, Lens Cap, Recorder, Filters and Wall Bracket

7. Exposure Counter.

The exposure counter (49) (figure 2) is a dial, on the right side of the body, carrying a scale divided into 50 graduations. The return movement of the operating handle (23) is transmitted by gears to the dial (49), so that it advances one graduation before each exposure to indicate how many pictures have been made on each roll. The exposure counter is set to zero (50) at the beginning of each roll by turning it clockwise.

8. Recorder.

The recorder (27) (figures 2 and 4) provides a means for photographing data in an area of approximately $\frac{1}{4} \times 3$ inches on the long side of the negative, the data being written by the photographer on a transparent card (29) attached to the metal recorder handle (28). A slot (22) to receive the recording device is provided in the back of the magazine cover (20). This cover cannot be attached or removed with the recorder inserted. (Refer to section IV.) The camera mechanism must be wound when the recorder (27) is inserted or removed.

9. Viewfinder.

The optical (Newtonian) oblique viewfinder (7) (figure 2) is located on the upper rear section of the cone. Depressing the small black leaf spring (10) protruding from the right front of its base, permits its lens (8) to be raised or lowered. The rear sight (9) (figure 7) positions itself automatically. When the photographer sights through the viewfinder, with the ball of the rear sight in line with the intersection of the red lines scribed in the finder lens, the area visible through the finder corresponds to the area covered by the negative.

10. Accessories.

a. Film Loading Guide—The film loading guide (13) (figure 5) is a sheet of hard rubber with a metal handle, that is inserted in the focal-plane slot (26) (figure 6) during the threading of the film to prevent the tongue of the leader from curling down into the body and preventing passage of the film.

b. K-20 Film Spools—The K-20 film spools are all-metal and will accommodate about 19 feet 6 inches of film $5\frac{1}{4}$ inches wide, in addition to 4 feet each of leader and trailer.

c. Lens Cap—The lens cap (19) (figure 4) is a felt-lined metal cap that is kept on the lens at all times, except when the camera is in use, to protect it against dirt and damage.

d. Filters.

(1) The filters (4) (figure 4) for the K-20 camera are in bayonet mounts, with three spring clips (6) engaging studs (17) on the lens mount to prevent their falling off in use. The filters are Wratten No. 25 (A, red) and No. 12 (minus-blue).

(2) To attach a filter, place it on the lens mount so that the pins on the lens mount engage the spring clips, and turn it clockwise until the projections on the springs pass over the pins and snap to secure the filter.

(3) To remove a filter, reverse the above procedure.

CAUTION: When handling filters, touch only the mount so that the glass will not be smudged or scratched.

e. Wall Bracket.

(1) The wall bracket (45) (figure 4) is attached to the fuselage of the plane with three No. 10-32 round-head screws. The camera should be attached to it when in the plane and not in use, as it cannot be dislodged accidentally.

(2) To attach the camera to the wall bracket: close the viewfinder, hold the camera by both handles with the lens down and the viewfinder toward the bracket, slip the pins that form the end of the viewfinder shaft into the two hooks (46) of the bracket, press the stud (3) (camera-support hook) against the bracket-spring (48), and lower the camera until the stud (3) is home in its slot (47) and the spring has forced the stud into the countersunk receptacles in the bracket. (See figures 2 and 4.)

(3) To remove the camera from the bracket, press the camera back against the spring, lifting it up and then away from the wall.

f. Carrying Case.

(1) The carrying case is made of fiber and accommodates one K-20 camera and all its accessories, plus two spare rolls of film.

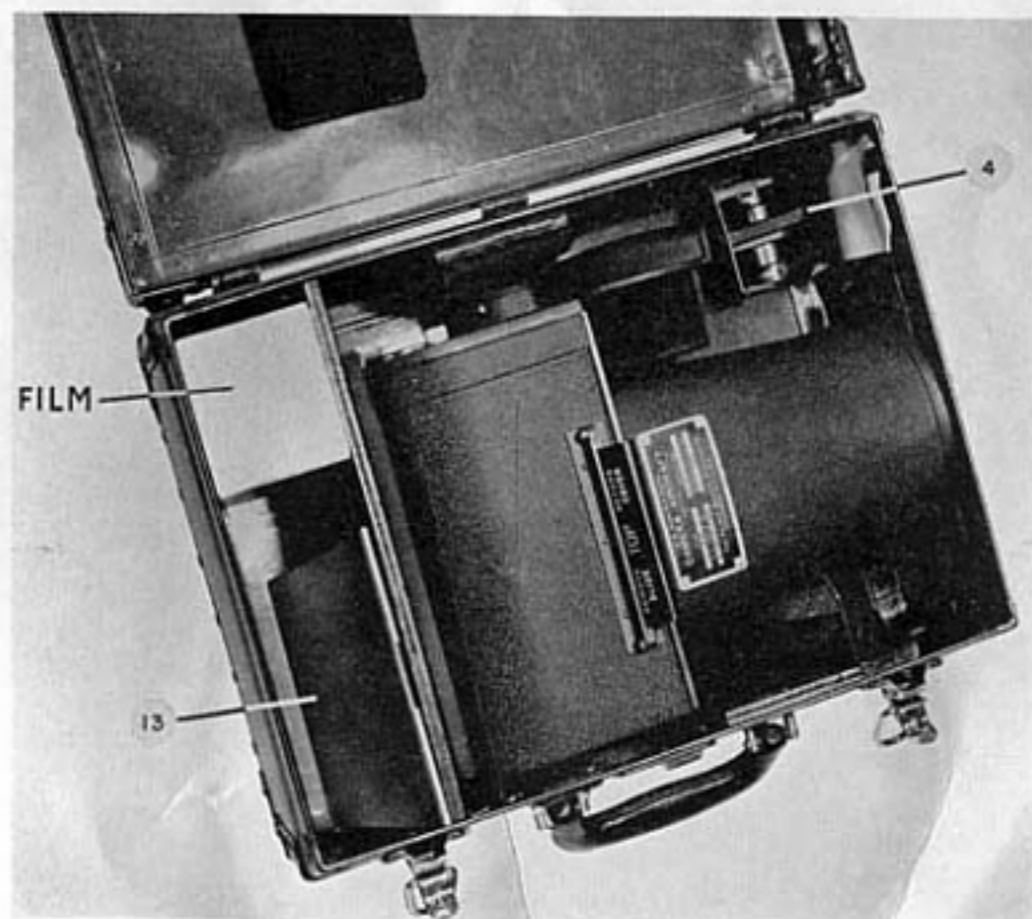

Figure 5—Complete Outfit in Case

(2) The disposition of equipment in the carrying case is shown in *figure 5*. The camera should be placed in the case with the recorder inserted, the name plate up, and its back toward the partition (i. e., with the operating handle next to the hinge). The filters (4) are placed in their special compartment at the right-rear corner (be sure to snap the cover). The block inside the lid will exert a slight pressure on the magazine cover to hold the camera tight when the lid is closed. The compartment at the left end of the case is for film (50), and the film-loading guide (13) may also be kept in this compartment.

(3) To remove the camera from the case (*figure 5*), grasp it by both handles and lift it *straight up*. When removing filters from their compartment, handle them by the edge of the mount only, to avoid smudging the glass.

11. Exposure Counter.

a. A Veeder-Root exposure counter, visible when the magazine cover is removed, is provided to indicate the number of cycles through which the camera has operated. After each 10,000 cycles the entire mechanism—especially the shutter—should be thoroughly overhauled.

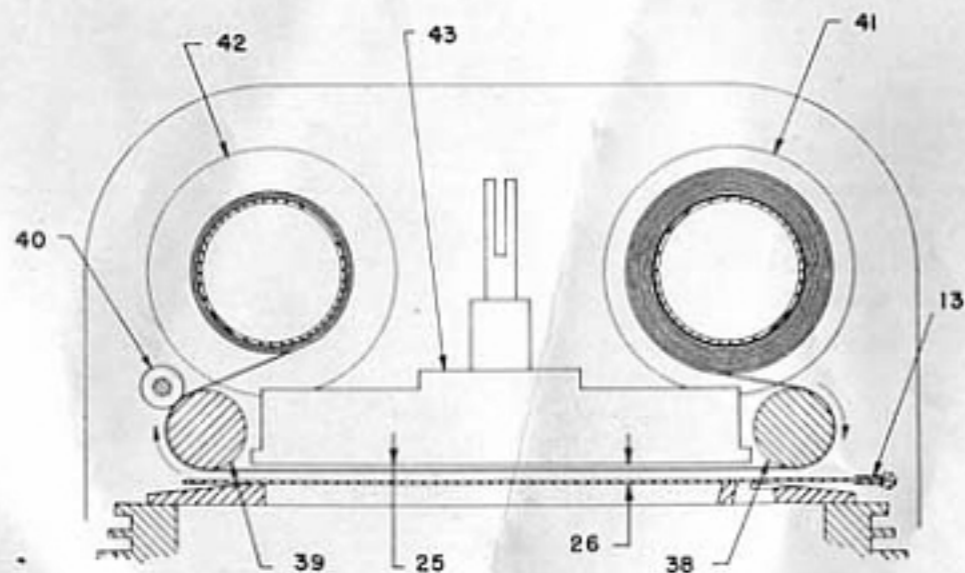

Figure 6—Method of Loading Film

SECTION IV PREPARATION FOR USE

1. General

CAUTION: Do not operate the camera with nothing in the focal plane slot, because the vacuum back is not designed for operation undamped. If it should be necessary to operate unloaded, insert the film-loading guide (13), or a piece of paper or old film, under the pressure plate (25) to check the free movement of the vacuum piston. (See *figures 3 and 6*.) Do not force any part or movement. Difficulty indicates that something is wrong, so check back on your previous adjustments before proceeding. Always release the shutter before putting the camera aside. When the mechanism and shutter are tripped and the cover removed, do not press down on the vacuum piston. This will upset the operating cycle and require disassembly of both the camera and shutter mechanism for repairs to restore correct operation.

2. Opening and Closing the Camera.

a. To open the camera: stand the camera on its nose with the top (viewfinder) away from you, remove the recorder (27), unscrew the knurled cover-screw knob (21) on the left side of the magazine cover (20), and slide the cover to the left and off the camera. The cover screw is prevented from falling out of the cover by a retaining clip. (See *figure 2*.)

b. To close the camera: slide the magazine cover (20) onto the back of the camera, making sure that the ridges and grooves of the light-trap are properly engaged, and that the recorder (27) is not inserted. Do not force a fit. Difficulty indicates that the cover is not properly placed on the body. Secure the cover by inserting the cover-screw (21) in its socket and setting it up handtight. Insert the recorder as instructed below.

3. Loading the Camera.

a. First stand the camera on its nose with the operating handle (23) to your right; then remove the magazine cover (20) as directed above. See that the mechanism is tripped, so that the pressure plate (25) (*figures 3 and 6*) is raised to permit introduction of the film under it. If it is necessary to trip the camera, check the motion of the vacuum piston (44) with a finger to prevent its hammering, making sure the finger is not caught under the crosspiece as the piston rises.

CAUTION: Do not turn the take-up knob (34) (*figure 2*) unless the mechanism is tripped.

b. As the film is somewhat protected by its leader, it may be loaded into the camera in a very subdued light. Place an empty K-20 spool in the take-up end (the side away from you, toward the viewfinder), making sure that the small crosspiece on the end of the drive shaft (33) engages the slot in the center of the spool flange, and that the pin in the far lefthand spring (35) is in the hole in the other flange. (See *figure 3*.)

c. Place a full K-20 film spool in the supply end in such a way that the tongue of the leader points up when it is toward you, which will cause the film to unwind from the bottom of the roll. Break the seal and draw out about 10 inches of the leader.

d. Insert the film-loading guide (13) in the focal-plane slot (26) (*figure 6*), making sure the pressure plate is raised.

e. Pass the tongue down, around, and forward under the black guide roller (38) and through the focal-plane slot (26) above the loading guide, as shown in *figure 6*. Turn the camera around so the take-up spool faces you. Bring the leader up and back between the bright metering roller (39) and the two rubber pressure rollers (40), lifting the pressure rollers to facilitate passage.

f. Remove the film-loading guide (13).

g. Insert the tongue in the lateral slot in the empty take-up spool (42) (*figure 6*), and make sure the leader is centered between the flanges and feeds straight. Then wind two complete turns of film on the spool with the take-up knob (34) (*figure 2*). If this knob will not turn, wind and trip the mechanism with the operating handle.

b. Replace the magazine cover and recorder.

i. Wind and trip the mechanism eight times to bring the sensitized film into position in the focal plane. Be sure the mechanism is tripped after the last preliminary winding.

j. Set the exposure-counter (49) at 50 (zero), and the camera is ready for operation.

4. Inserting the Recorder.

a. The recorder (*figures 2 and 4*) consists of a sheet of matte-surface cellulose-acetate film (29) secured to the recorder handle (28), and is carried in the camera in the recording-plate holder (22) (*figure 2*). Wind the mechanism and insert the recorder in the slot of the recording-plate holder on the bottom of the magazine cover, in such a way that the matte-surface is toward the film. (The words "Top—remove slide before cover" should face the operator when the camera is in operating position.)

b. Information can be written in the three rectangular clear areas on the matte-surface of the acetate sheet (*figure 4*) with a lead pencil of grade HP softer.³ To facilitate writing, place the recorder on a flat surface, so the curves down over the edge.

CAUTION: When inserting and removing the recorder, or pull it straight in or out. Twisting it from side to side is liable to tear the acetate sheet loose.

5. Opening and Closing the Viewfinder.

a. To open the viewfinder (*figure 2*), depress the black leaf spring (10) under the right front of the finder, and raise the finder frame to the vertical. The rear sight (9) (*figure 7*) is automatically brought into position by a torsion spring (11) on its shaft (12), and the whole finder is maintained in operating position by the leaf and torsion springs.

b. To close the viewfinder, again depress the leaf spring 10 and push back on the top of the finder frame until it snaps into the folded position.

SECTION V

OPERATION

1. General.

- Remove camera from carrying case or wall bracket.
- Load the camera.
- Remove the lens cap.
- Examine the lens and, if necessary, clean it as directed in *section VI*.
- Attach a filter, if it is to be used.
- Write desired information on the recorder.
- Raise the viewfinder.

2. Setting Lens and Shutter.

Determine the diaphragm opening and shutter speed required by the prevailing conditions for the film and filter in use, and set the diaphragm knob and retard knob accordingly.

3. Checking the Exposure Counter.

To keep track of the amount of film remaining in the camera, check the exposure counter.

4. Holding the Camera.

The camera is held as shown in *figure 7*, with the fixed handle in the left hand and the operating handle in the right hand. The right index finger lies on the trigger, the back of the magazine is pressed against the chin, and the lower rear edge of the magazine rests on the chest. Keep the elbows close to the chest and do not bring any part of the camera in contact with any portion of the plane, lest the image be blurred by vibration.

Camera in operating position (*figure 7*) as directed in the preceding section. The rear sight through the viewfinder at the area to be photographed is in line with the intersection of the finder lens, the area visible in the finder corresponds to the area to be photographed.

b. Before an exposure is to be made, rotate the operating handle fully forward and return it. This advances the film, cocks the shutter, sets the vacuum mechanism, and advances the exposure counter.

c. To make the exposure, squeeze the trigger gently and steadily to avoid jarring the camera.

d. Turn the operating handle forward and fully back to prepare the camera for the next exposure.

e. Refer to the exposure counter from time to time, as a check on the amount of film being used.

f. When 50 exposures have been made, unload as follows:

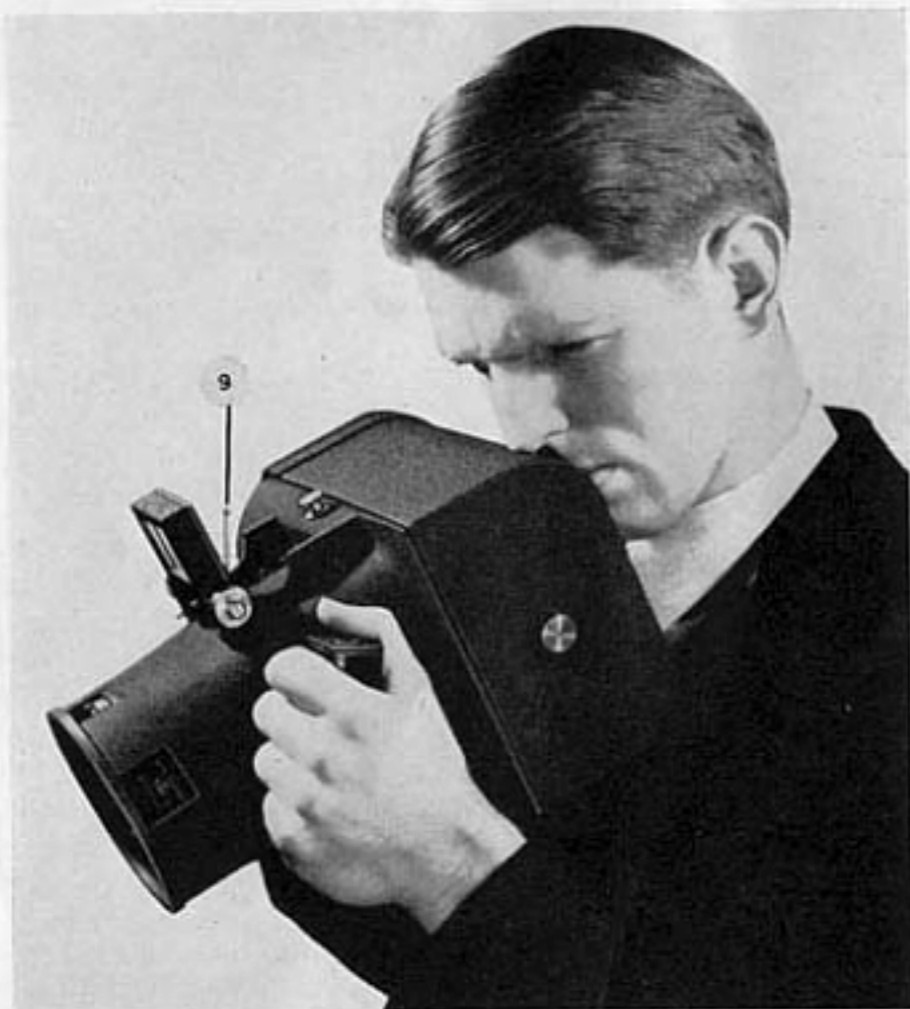

Figure 7—Holding the K-20 Camera

6. Unloading.

- a. When all film is exposed, it is necessary to unload and reload the camera.
- b. Operate the camera about 10 or 12 times, until its freer movement indicates that all the trailer has passed through the focal-plane slot and is on the take-up spool.
- c. Open the back, as directed in *section IV paragraph 2*, remove the full spool, and seal it. This operation should be carried on in a subdued light.
- d. Replace the magazine cover or reload, as directed above.

7. Storage.

When the camera is not in use, keep it on the wall bracket or in its case. Instructions for placing it in the case are given in *section III, paragraph 10*.

SECTION VI

INSPECTION, MAINTENANCE AND LUBRICATION

1. Inspection and Maintenance.

a. General.

- (1) Aircraft cameras and their accessories are precision instruments and are to be handled and stored as such.
- (2) The shutter of each camera is a standard unit and can be interchanged with other shutters.
- (3) The focusing posts are adjusted to their particular lens and should not be interchanged. If a lens is changed to another shutter, the focusing posts must also be transferred.
- (4) The lens-mounting surfaces on the shutter case and on the shutter cover are machined at the same time for each shutter assembly, and are marked with duplicate numbers for identification to preserve the exact centering of the lenses. These two parts should not be interchanged with a cover or case from another unit.
- (5) The front and rear elements of a lens are matched, and are not interchangeable with an element of another lens unit.

b. Cleaning.

- (1) The proper method of cleaning lenses, etc, is to first brush off dust or grit with a dry, clean, camel's hair brush. Then using lens tissue or a soft, clean, dry, lintless cotton or linen cloth, polish them gently and thoroughly. If it is necessary to moisten the lenses while cleaning, do so by breathing upon them. Never use water, alcohol, cleaning fluid, or any other kind of liquid.
- (2) To clean the rear lens element of the camera, it is necessary to remove the shutter. Refer to *paragraph 1-d.*, this section.

c. Removing the Lens.

- (1) If it should be necessary to remove the rear lens element from the shutter, it is first necessary to soften the shellac with which it is sealed.
- (2) Place one drop of alcohol at any point on the joint between the lens and the shutter; it will spread all the way around. Allow it to stand for three minutes, and the rear element may then be unscrewed with the fingers.
- (3) After replacing the rear element, seal it again by placing at any point on the joint one drop of mixture made up of 7 parts of grain alcohol and 1 part of any good shellac.

d. Removing the Shutter. (See figure 8.)

- (1) Wind and trip the camera.
- (2) To remove the shutter, take out the three large fillister-head screws, and lift it out carefully.
- (3) After this has been done, extreme care should be exercised not to disturb the trip-coupling and upper spring-cup on the shutter (*figure 8*), or the operating handle on the camera, in order to reassemble the shutter to the camera body correctly. If they are disturbed, it will be necessary to retime the shutter. Refer to *paragraph 1-f.*, this section.



Figure 8—Shutter—Rear View

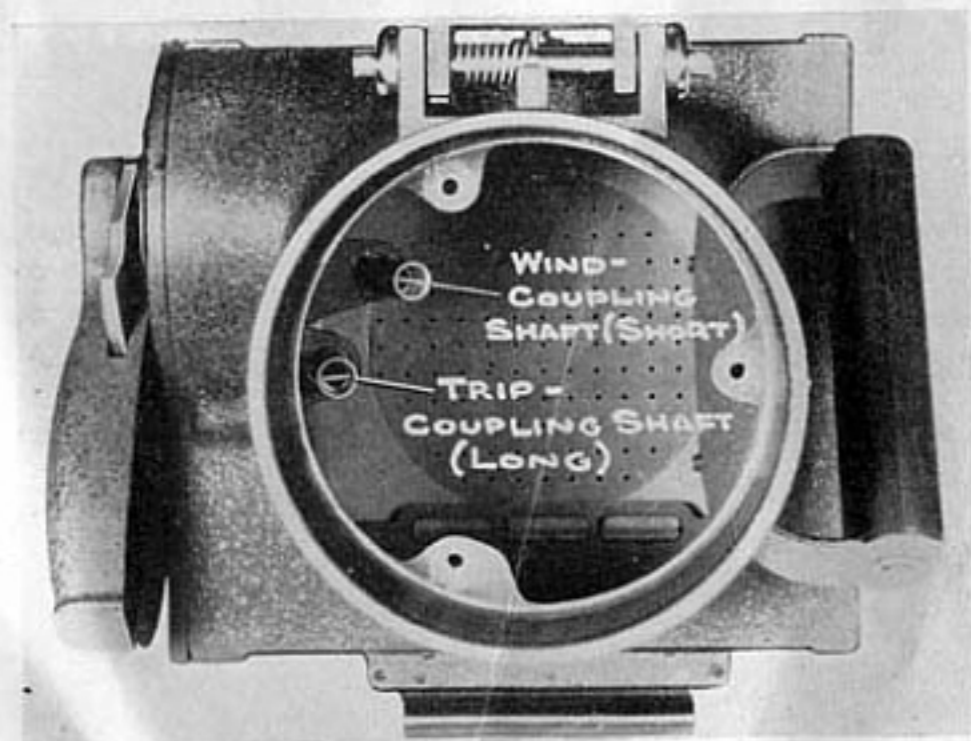

Figure 9—Camera Body—Interior View

e. Replacing the Shutter. (See figure 9.)

(1) Before replacing the shutter, make certain that the positions of the wind- and trip-couplings and the wind- and trip-coupling shafts have not been disturbed. If they have it is necessary to retune the shutter. (Refer to the following paragraph 1-f.)

(2) Insert a long pin into one of the tapped holes in the bosses inside of the cone. Insert the other end of this long pin into the corresponding mounting hole on the shutter, taking care that the wind- and trip-coupling on the shutter line up with the coupling rods in the camera. Slide the shutter into place, guiding it by means of the long pin so that the screw holes in the shutter line up with the tapped holes on the mounting bosses after the shutter is completely down in the cone.

f. Timing the Shutter.

The shutter of the K-20 camera has an initial tension of one-eighth turn. When it is removed from the camera it must be retimed before replacement. Likewise, when it is tripped twice in succession without being recocked between trippings, as occurs when the vacuum piston is pushed down by hand after the shutter is tripped, it will remain open after the second tripping. Before pictures can be taken with the camera, after this has happened, the shutter must be removed from the camera, reset, and reinstalled. The following instructions cover this servicing:

(1) Remove the shutter from the camera.

(2) Wind the camera and pull the trigger. Looking into the cone, both the coupling-rod pins should be radial if the camera is in proper adjustment; i. e., both pins in the coupling tubes point approximately at the center of the cone. If the shorter coupling-rod pin does not point toward the center of the camera, it can be twisted counterclockwise with the fingers until it clicks into place pointing in the proper direction.

(3) Time the shutter as follows:

(a) Set the retard knob at 1/500 second.

(b) With the aid of a screw driver rotate the trip coupling on the shutter (the shorter of the two slotted balls) clockwise and counter-clockwise until no further clicks are heard, and then turn counter-clockwise as far as possible.

(c) Now with the fingers turn the wind coupling (the longer of the two slotted balls) counter-clockwise until a click is heard after the force of the spring has been felt. Release the coupling and, if the winding has been done properly, a rod placed in the slot of the ball would point along one edge of the lens.

(4) Replace the shutter as instructed in the preceding paragraph 1-e.

(5) Wind and trip the camera, watching the shutter to make sure that it is operating properly.

(6) Reinsert and tighten the three large fillister-head screws which were removed.

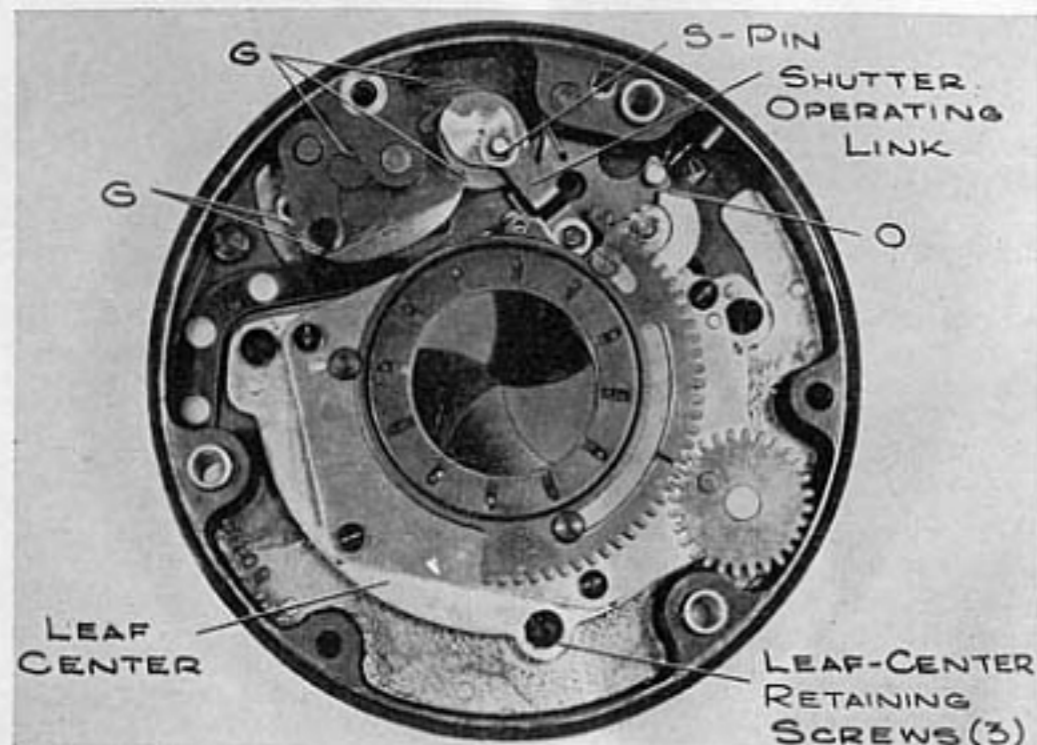

Figure 10—Lubrication—Interior of Shutter

2. Lubrication.

a. General.

(1) Oil and grease should be placed at the points indicated by "O" or "G" in figures 10 and 11, or where otherwise stipulated. Use only the oil and grease specified, as variation from specifications will cause trouble at low temperatures.

(2) The oil specified is Oil, Lubricating, for Aircraft Instruments and Machine Guns, U. S. Army Specification No. 2-27.

(3) The grease specified is Grease, High Melting Point, AAF Specification No. 3560, soft grade.

(4) When applying lubricants use them very sparingly and take extreme care to remove all excess.

b. Shutter. (See figures 10 and 11.)

(1) The shutter should be lubricated every 6 months, or after approximately every 5000 operations.

(2) A thin film of grease, AAF Specification No. 3560, should be applied only at the points indicated, and a fraction of a drop of oil, U. S. Army Specification No. 2-27, should be carefully applied to the teeth of the retard segment. (See figure 15.)

(3) To lubricate the leaf center, remove the S-pin and the three leaf-center retaining screws. Lift out leaf center and put a fraction of a drop of oil, U. S. Army Specification 2-27, on each of the five shutter-leaf pivots, wiping off all superfluous oil immediately. The leaf center must not be disassembled.

c. Camera Body.

(1) The lubrication given the camera body mechanism at the time of manufacture should be sufficient to last indefinitely.

(2) Should unusual conditions require the mechanism to be relubricated, the teeth of gears and cams should receive an exceedingly sparing film of grease, AAF Specification No. 3560. Where they are carried in the casting, a fraction of a drop of oil, U. S. Army Specification No. 2-27, should be applied to the two film-roller bearing pins, the film-metering roller bearing, the bearing surfaces of the film-metering pinion, and the two ends of the pressure-roller shaft. The vacuum-piston rod should receive one small drop of oil, U. S. Army Specification 2-27.

(3) No lubrication should be applied to the vacuum-piston edge or vacuum-cylinder wall.

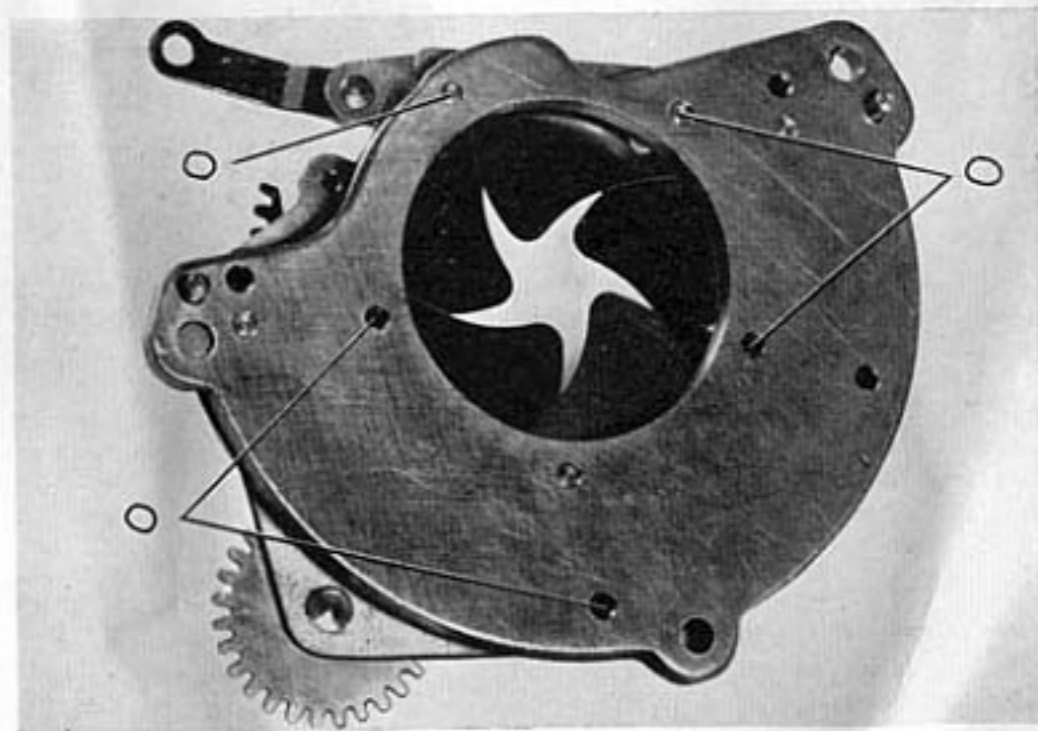

Figure 11—Lubrication—Leaf Center

SECTION VII

DISASSEMBLY, INSPECTION, REPAIR, REASSEMBLY AND FINAL TEST

1. Disassembly.

a. When disassembling various units for inspection and repair, care should be taken to note the specific order in which the various assemblies and sub-assemblies are taken apart in respect to their details.

b. For the proper order of disassembly of any particular unit, the reverse order of reassembly should be followed. (See paragraph 4, this section.) The re-assembly instructions are detailed enough to require no particular disassembly instructions.

c. During disassembly of any or all parts of the camera, a careful inspection of each part should be made and any replacement or repair that is necessary must be noted and recorded.

2. Inspection.

If, upon disassembly, inspection reveals that a part is in need of replacement which is a piece of an assembly or subassembly that is held together by a taper pin, the whole assembly should be replaced, even though only a single detail part of same may be in need of replacement. This procedure is necessary due to the fact that, in taper-pinned assemblies, only the dimensional relationships of individual parts are held on shafts, etc., in exact correlation, and only complete assemblies are interchangeable. Individual detail parts are not interchangeable from one assembly or subassembly to the other if they are a definite part of a taper-pinned assembly or subassembly, because of the fact that, in regulation manufacturing practice, fixtures and jigs control only the exact dimensional positions of parts of assemblies for taper pinning. The location of the taper pins themselves are not held in close enough control to allow their being interchangeable on two assemblies or subassemblies of the same kind.

3. Repair.

All screw threads and taps should be rethreaded where necessary, and screws, bolts, nuts and washers replaced if burred or worn, with like parts in kind and size. Loose rivets should be replaced. All moving parts, gears, cams, shafts, bearings, etc., showing excessive wear should be replaced and properly fitted. All parts should be inspected and tested for their assigned tolerances and, if found to exceed the allowable figures, these parts must be discarded and new parts installed. The replacements of all screws which originally had shellac applied to them, should be dipped in shellac, Federal Specification No. TT-S-271.

4. Reassembly.

a. General. (See figures 12 and 13.)

(1) In reassembly, the sequence of assembly of details, subassemblies and assemblies is indicated by the order of their appearance in the text.

(2) In many instances, the drawing numbers given refer to simple sub-assemblies, which require no individual treatment as to their respective details.

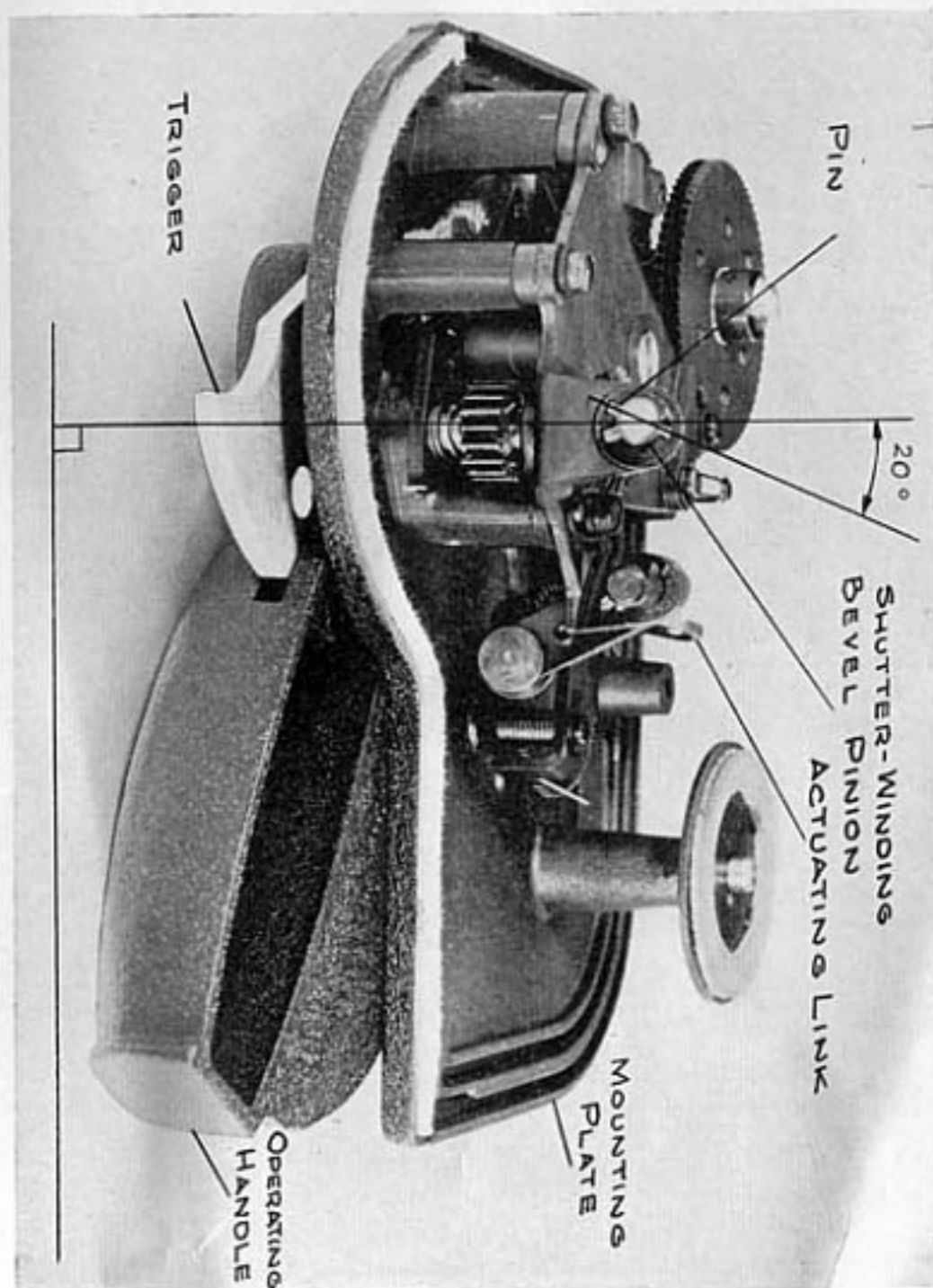

Figure 12—Setting the Angle of the Pin

Restricted

(3) In the system from the operating handle to the shutter-winding bevel pinion, a difference in accumulated tolerances may occur should it be necessary to make any repairs to the mechanism assembly which would require the replacement of worn or broken parts with new ones.

(4) This may necessitate replacing the shutter-winding bevel pinion with a new one in which the angle of the location of the lower pin must be determined, the hole drilled, and the pin inserted.

(5) To determine whether or not to replace the shutter-winding bevel pinion it is necessary to determine whether or not the angle at which the lower pin positions itself conforms to a setting of exactly 20 degrees clockwise from the vertical with all backlash removed, when the operating handle is at its stop at the completion of a winding cycle.

(6) This can be checked in the following manner:

(a) Trip the mechanism assembly by pressing the trigger and pushing the actuating link down, and then moving the operating handle forward and backward through a complete winding cycle.

(b) Hold the operating handle firmly against its stop in the wound position.

(c) To set the shutter-winding bevel pinion, in order to determine whether the angle of the location of the lower pin is correct: first ratchet the shutter-winding bevel pinion in a clockwise direction until it assumes a position approximately 20 degrees clockwise from the vertical; then turn it counter-clockwise as far as possible. This will take up all backlash in the entire system, while still holding the operating handle firmly against its stop in the wound position.

(d) At this point the position of the lower pin should be 20 degrees clockwise from a vertical line intersecting the center of the winding-bevel pinion, which constitutes the proper setting.

(e) The vertical line intersecting the center of the winding-bevel pinion should be at a right-angle to a line parallel to the straight edge of the mounting plate.

(7) Should the angle as determined be within plus-or-minus 1 degree of the proper setting, the shutter-winding bevel pinion can be re-used after repairs have been made.

(8) Should the angle as determined be in excess of plus-or-minus 1 degree of the proper setting, a new undrilled shutter-winding bevel pinion must be assembled into the mechanism assembly, the backlash removed, the correct angle determined, the lower pin-hole properly located and drilled, and the pin inserted.

(9) Means have been provided for making an adjustment on the trip-link shaft which resets the shutter on the return stroke of the operating handle. An adjustment of 5 degrees is possible by turning the trip-link adjusting stud. The resetting of the shutter must be adjusted so that, when the piston is released slowly with the fingers (after having been wound by means of the handle in the first place), the shutter shall operate when the piston is plus $\frac{1}{8}$ inch or minus $\frac{1}{4}$ inch from the top of the cylinder.

Restricted

(10) To determine whether the reset adjustment of the trip-link shaft is correct, it is necessary to check in the following manner:

(a) Time the shutter, and assemble it to the camera body.

(b) Wind the camera, and hold the piston down with the fingers of left hand while pulling the trigger with right hand. Let the piston up very slowly. If the shutter operates when the piston is $\frac{3}{8}$ inch from its stop at the top of the cylinder, the shutter is properly adjusted.

(c) If, when the operating handle is pulled backward to the fully wound position, a click is not heard at approximately the same time when the edge of the handle is crossing the boss on the side of the camera (approximately 15 degrees before the end of the handle travel), do not wind the camera again as the absence of this click means that the shutter has not been cocked and will not be released when the piston comes up. In this case, loosen the washer-head screw and turn the trip link adjusting stud until the click is heard.

(d) If, however, no click is heard (*do not wind camera again as this would cause serious damage*), loosen the washer-head screw and turn the trip-link adjusting stud until the click is heard.

(11) Should it be impossible to make the shutter reset by turning the trip-link adjusting stud, the shutter should be removed from the camera body and examined for a reason for the failure to reset.

b. Mechanism Assembly (K20D-H2). (See figure 13.)

(1) Side Plate Assembly (K20D-H3).

(a) To the side-plate casting assembly (K20C-H4) secure the following: Safety-latch return spring (K20B-443) with screw (500-2-4) and lock washer (936-A2), two full-stroke ratchets (K20B-30) with four screws (AN505-6-4), guard rail (K20B-32) with two screws (AN505-4-4), counter-arm stop (K20B-172) with two screws (500-4-4), two lock washers (AN935-4), and two drill-rod pins (F79-2-6), and the counter-stop spring (K20B-144) with screw (500-4-4) and lock washer (AN935-4).

(b) To the counter shaft assembly (K20B-A17) add the counter-spring washer (K20B-21). Apply a thin film of grease, AAF Specification No. 3560, soft grade, to the film exposure-counter shaft (K20B-20) and insert it through the side-plate casting assembly (K20C-H4). To the other end add the exposure-counter dial assembly (K20B-A16) and secure with taper pin (385-60-3).

(c) Place the counter-actuating arm assembly (K20B-H5) on the counter-actuating arm pivot (K20B-498); secure with a retaining clip (F78-3), and add the counter-arm return spring (K20B-531).

(d) Fasten the film-spool friction plate assembly (K20B-A19) to the side-plate casting assembly (K20C-H4) with the film-spool casting assembly (K20C-H4) with the film-spool pivot (K20B-38) and drill-rod pin (F79-2-8).

(2) *Operating Handle Assembly (K20C-H10).*

(a) Secure the operating-handle trigger (K20B-84) of the trigger assembly (K20B-H11) in operating handle (K20D-541) with a trigger-screw roller (K20B-80) and a trigger-handle screw (K20B-77). Fasten the operating handle (K20D-541) to the winding-handle shaft (K20B-544), the bearing surfaces of which have received a film of grease, AAF Specification No. 3560, soft grade, with a taper pin (385-20-10); and then add the operating-handle spacer (K20B-154) before inserting into the side plate assembly (K20D-H3).

(b) Insert the trip shaft (K20B-545), of the remainder of the trigger assembly (K20B-H11), after applying a thin film of grease, AAF Specification No. 3560, soft grade, to the surfaces of the slot in it, and adding the four trip-shaft shims (K20B-609), through the side plate assembly (K20D-H3) and the operating-handle trigger (K20B-84), to which it is secured with a trigger-locking screw (K20B-33).

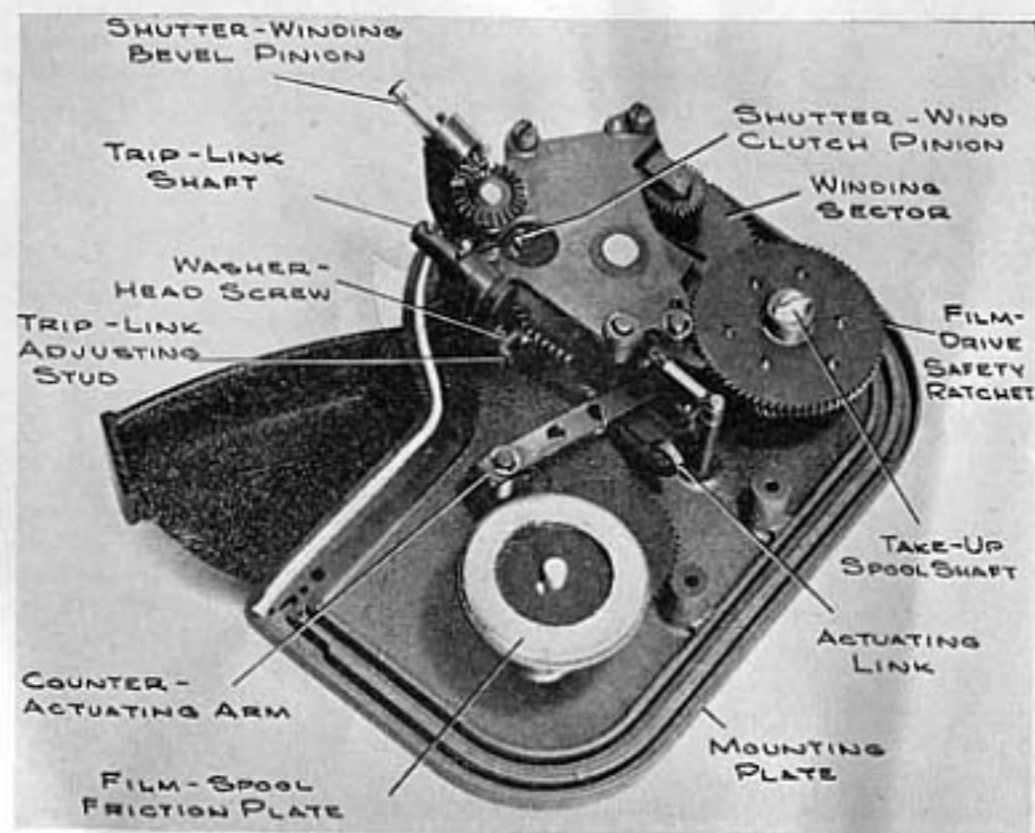

Figure 13—Mechanism Assembly

(c) Place the following on the winding-handle shaft (K20B-544): Actuating link assembly (K20B-H13), after applying a thin film of grease, AAF Specification No. 3560, soft grade, to the wearing surfaces of the actuating disc (K20B-538); actuating-disc spacing collar (K20B-483); and the winding-sector assembly (K20C-H15), which is secured with taper pin (385-50-5). A thin film of grease, AAF Specification No. 3560, soft grade, is to be applied to the teeth of the winding sector (K20C-438). The trigger spring (K20B-553) is attached

to trip-lever return-spring pin (K20B-448) and to the trigger-spring anchor stud (K20B-155). The counter-actuating arm (K20B-496) should be checked to see that it is riding on the trip-lever return-spring pin (K20B-448) of the winding sector (K20C-438).

(3) *Take-Up Spool Ratchet Assembly (K20B-H6).*

(a) To the take-up spool shaft assembly (K20B-H7) add the film-winding washer (K20B-457), and then add the film-stop ratchet (K20D-403) in such a manner that it is held in position by the three film-stop ratchet guides (K20B-529). Position the three film-winding pawls (K20B-450) on the three pawl shafts (K20B-456), making certain that the end of each pawl fits into its slot in the film stop ratchet (K20D-403).

(b) Place the film-drive ratchet assembly (K20B-H9) on the take-up spool shaft assembly (K20B-H7), so that the film-winding pawls (K20B-450) can mesh with the teeth of the film-drive ratchet (K20B-453). Position the three film-winding pawl return-springs (K20B-481) in the three large slots in the film-stop ratchet (K20D-403), making certain that they bear against the pawls. Add the film-winding washer (K20B-457) and secure by placing the three clips (F78-1) over the three pawl shafts (K20B-456). Then add the washer (K20B-462).

(c) Insert the shaft of the assembly through the hole in the side plate assembly (K20D-H3). Secure the take-up spool shaft knob (K20B-8) to the take-up spool shaft (K20B-432) with a taper pin (385-60-3).

(4) *Mechanism Rear Plate Assembly (K20C-H16).*

(a) Before assembling the mechanism rear plate assembly (K20C-H16), apply a very thin film of grease, AAF Specification No. 3560, soft grade, to the shafts that run in aluminum bearings, and to the bevel-gear teeth. Add the following to the mechanism rear plate (K20D-451): washer (K20B-462), film-metering cam assembly (K20B-H17) and the film-metering cam pivot (K20B-463). The metering-cam follower-arm assembly (K20B-H18) is secured to the magazine rear plate (K20D-451) with a retaining clip (F78-3). The ratchet-pawl shaft (K20B-445), of the ratchet pawl assembly (K20B-H29), has added to it washer (K20B-489) and is inserted into the magazine rear plate (K20B-451) and held with a retaining clip (F78-3).

(b) Pass the shaft of the shutter-winding bevel pinion (K20C-401) through washer (K20B-462), mechanism rear plate (K20D-451), washer (K20B-462) and then add the two drill-rod pins (K20B-523). Position the washer (K20B-462) and the shutter-winding bevel gear (K20C-402) so that it will mesh with the shutter-winding bevel pinion (K20C-401). The shutter-winding gear shaft (K20B-431) is inserted through the mechanism rear plate (K20B-451) and the shutter-winding bevel gear (K20C-402), which is secured to it with taper pin (385-60-4). Add the washer (K20B-462) and drill-rod pin (K20B-585). Then add the shutter-wind clutch pinion (K20B-493), washer (K20B-462), shutter-wind clutch spring (K20B-458) and the safety latch (K20B-449). Add the washer (K20B-462) to the trip-link shaft (K20B-502) of the shutter-trip shaft assembly (K20B-H20), and insert it into the mechanism rear plate (K20B-451). Then add the washer (K20B-462) and the two drill-rod pins (K20B-523).

(c) Position the mechanism rear plate (K20B-451) to the side plate assembly (K20D-H3) in such a manner that, when the operating handle (K20D-541) is in the extreme rear position and the teeth on the winding sector (K20C-438) and those on the wind-clutch pinion (K20B-493) are engaged, the lower pin in the shutter-winding bevel pinion (K20C-401) will form an angle of 20 degrees measured clockwise from the vertical center line of the base of the shaft of the shutter-winding bevel pinion (K20C-401). (See figure 12.)

(d) Secure the mechanism rear plate assembly (K20C-H16) to the side plate assembly (K20D-H3) with two pins (F79-4-12), three screws (500-8-8) and three lock washers (AN935-8). Slip the trip-actuating link (K20B-430) on the trip-link securing wire (K20B-501). Secure the cam-follower arm return-spring (K20B-447) to the cam-follower arm return-spring pin (K20B-446) and to the spring pin (K20B-490). The film-spool holding-pawl spring (K20B-492) is secured in the pin on the clutch pawl, and to the spring pin (K20B-490).

(5) *Vacuum Back Assembly (K20C-H22).* (See figure 14.)

(a) Assemble the vacuum-piston leaf spring (K20B-110) and the vacuum-piston rod (K20B-142) to the vacuum-piston assembly (K20B-A39). Insert the two latch-pin springs (K20B-226), one into each side of the vacuum-cylinder (K20B-157). Apply a small drop of oil, U. S. Army Specification No. 2-27, to each of the latch-pin assemblies (K20B-A40) and insert them over the latch-pin springs (K20B-226). Apply a small drop of oil, U. S. Army Specification No. 2-27, to the vacuum-piston rod (K20B-142) and insert the vacuum-piston assembly (K20B-A39) through the base of the vacuum-cylinder (K20B-157). Then stake the vacuum-disc (K20B-207) to the base of the vacuum-cylinder (K20B-157). The piston-and-cylinder vacuum-back assembly (K20C-A7) is positioned on the film-guide vacuum-back assembly (K20C-H21). Position the two latch-pin stops (K20B-23) on the two vacuum-back guide pins (K20B-183), and if necessary add the latch-pin shims (K20B-329) and (K20B-587). Secure the two screws (AN515-2-3) and two lock washers (936A2).

(b) The film-roller assembly (K20B-A9) is added to the film-guide vacuum-back assembly (K20C-H21) and held with two film-spool retaining-links (K20B-581), two screws (F6-44RP) and two lock washers (AN935-4). The film-metering roller assembly K20B-H23, after a thin film of grease, AAF Specification No. 3560, has been applied to the film-metering pinion (K20B-460), is secured to the film-guide vacuum-back assembly (K20C-H21) with a film-spool retaining link (K20B-581), screw (F6-44RP), lock washer (AN935-4) and a roller-retaining pin that is held in place with shellac, Federal Specification No. TT-S-271. Apply a small drop of oil, U. S. Army Specification No. 2-27, to bearings of the film-rollers. The pressure-roller assembly (K20B-H24) is secured in position with two retainer links (K20B-197) and two pressure-roller springs (K20B-143). Secure the take-up spool guide-rod (K20B-540) and the film-feed spool guide-rod (K20B-537) to the vacuum-back assembly (K20C-H22) with two retaining clips (F78-5).

(c) Secure the vacuum-back assembly (K20C-H22) to the camera cone (K20F-567) with two vacuum-back plate-locating screws (K20B-182), a vacuum-back plate screw (K20B-337) and a screw (AN505-4-7). Secure the mechanism assembly (K20D-H2) to the camera cone (K20F-567) with four screws (500-6-5) and four lock washers (936A6).

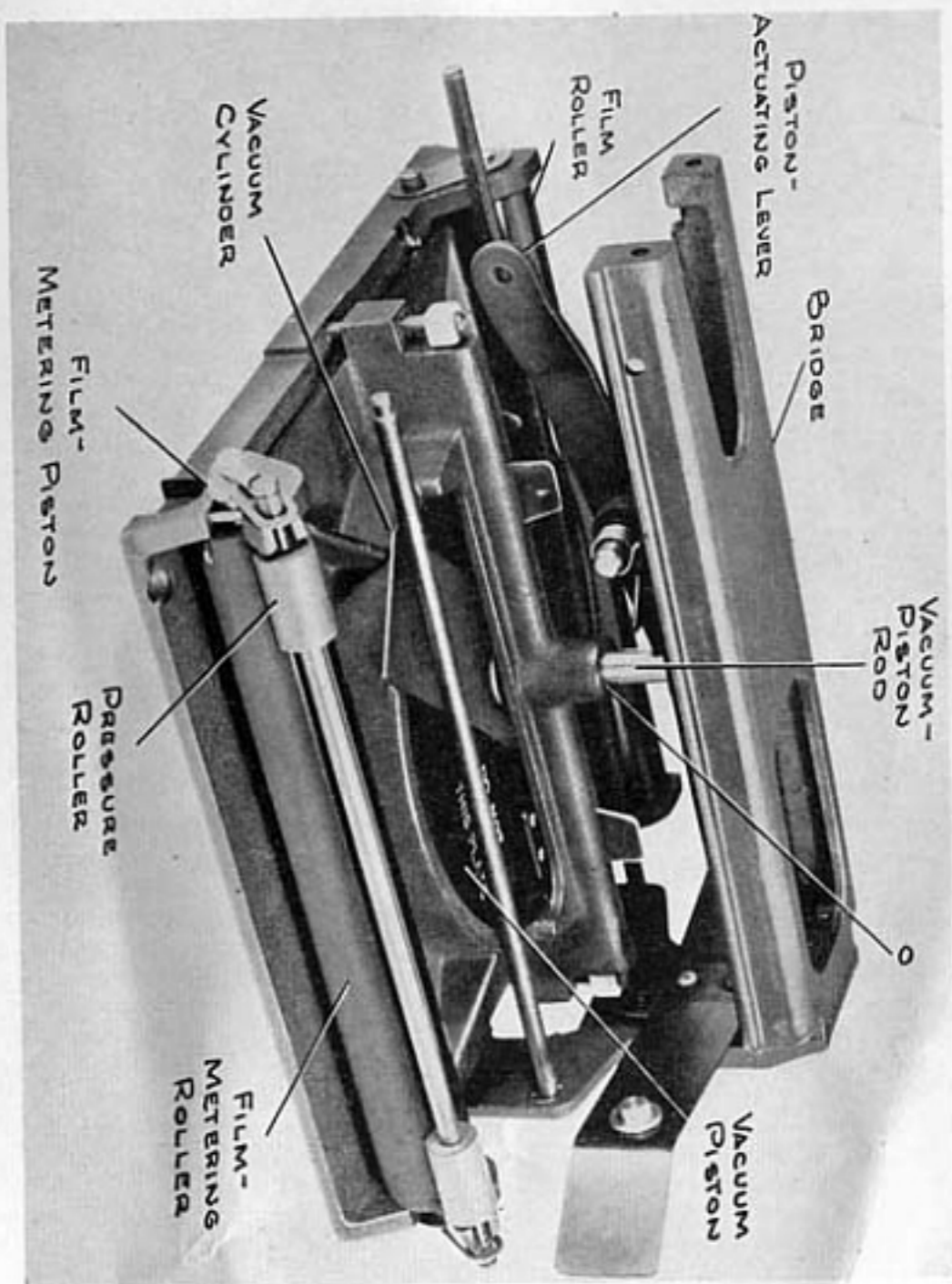

Figure 14—Vacuum Back Assembly

CAUTION: The end of the counter-arm return-spring (K20B-531) must rest on the film-feed spool guide-rod (K20B-537). Fasten the bridge assembly (K20B-H30) to the side plate assembly (K20D-H3) and to the vacuum-back assembly (K20C-H22) with two screws (500-6-7), two lock washers (936-A6), and two screws (AN505-6-16). Secure the actuating link (K20B-482) to the piston-actuating lever (K20B-98) with the actuating-link stud (K20B-56) and nut (AN-340-8). The vacuum-piston rod (K20B-142) is attached to the piston-actuating lever (K20B-98) by means of a cotter pin (AN380-3-2).

(6) *Cone Assembly (K20D-H25).*

(a) Position the viewfinder spring (K20B-209) and secure to the camera cone (K20F-567) with two screws (AN515-4-3) and two lock washers (AN935-4). The left-hand handle mount (K20B-578) is fastened to the camera cone (K20F-567) with two screws (AN510-10-6). Then assemble the left-hand handle (K20B-576) and the handle-retaining tube (K20B-577) to the left-hand handle mount (K20B-578). The camera-support hook (K20B-213) is secured to the camera cone (K20F-567) with a lock washer (AN935-416) and a nut (AN340-416).

(b) Secure the viewfinder collar (K20B-220) to the viewfinder shaft (K20B-106) with taper pin (F76-50-14). Secure one end of the viewfinder spring (K20B-41) to the viewfinder assembly (K20B-A31), and position the assembly on the camera cone (K20F-567). Pass the viewfinder shaft (K20B-106) through the shaft housing on the camera cone (K20F-567) and the viewfinder assembly (K20B-A31). Add and secure the viewfinder sight (K20B-107) with a screw (F22-D42), and bend the free end of the viewfinder spring (K20B-41) around it.

(c) The shutter assembly (K20E-F1) is timed according to the instructions given in *section VI, paragraph 1-f*, and secured to the camera cone (K20F-567) with three screws (501-10-20) and three lock washers (AN935-10).

c. Shutter Assembly (K20E-F1).

(1) Remove the spring housing (K20B-376) from the shutter case-and-cover assembly (K20D-F2). Add the spacer (K20B-608) to the shutter-trip cam assembly (K20C-F39), and apply a thin film of grease, AAF Specification No. 3560, soft grade, to the shaft of the assembly. Insert the shaft of the shutter-trip cam assembly (K20C-F39) through the cam-shaft bushing (K20B-373) which has received a thin film of grease, AAF Specification No. 3560, soft grade. Coat the base of the lower spring cup (K20B-374) with a thin film of grease, AAF Specification No. 3560, soft grade, and secure to the cam-shaft (K20B-372) with taper pin (F76-60-5). Add the cam-shaft collar (K20B-475), shutter spring (K20B-530) and the upper spring cup (K20B-370). Apply a thin film of grease, AAF Specification No. 3560, soft grade, to the face of the upper spring cup (K20B-370). Place the spring housing (K20B-376) over the shutter-cam shaft assembly (K20B-317), and secure with four screws (F6-63RP) and four lock washers (AN935-6). Add the wind-coupling spacer (K20B-473) and the spring clip (F78-4). To the side of the spring housing (K20B-376) add the following: the wind-stop pin (K20B-375) which has received a thin film of grease, AAF Specification No. 3560, soft grade, wind-stop pin spring (K20B-471) and screw (F11-E82).

(2) In the shutter case (K20D-366) (*figure 15*), position the following in order: spacer (K20B-414), snubber assembly (K20B-F16), shim (K20B-415), shutter-cam stop pawl (K20C-416), two shims (K20B-415), trip lever (K20B-740) and the shims (K20B-415) (1, 2, or 3 as required). Then add the snubber-cam stop retard-segment shaft (K20B-410) to which a small drop of oil, U. S. Army Specification No. 2-27, has been added. Add a thin film of grease, AAF Specification No. 3560, soft grade, to the working surfaces of the trip lever (K20B-423), trip cam (20B-419), and to the stopping surfaces of the shutter-cam (K20B-420).

(3) Position the following in the shutter case (K20D-366): retard-segment spacer (K20B-469), retard-segment assembly (K20B-F41), retard-segment spacer (K20B-628) and retard-segment spring (20B-465). Then add the snubber-cam stop retard-segment shaft (K20B-410), which has received a small drop of oil, U. S. Army Specification No. 2-27. Position the retard pallet (K20B-470) on the retard-pallet stud (K20B-367) to which a small drop of oil, U. S. Army Specification No. 2-27, has been added; and secure with washer (K20B-534) and S-pin (K20B-629).

(4) Remove the trip coupling (K20B-409) from the trip shaft assembly (K20C-F14), and insert the trip shaft (K20B-408) of the remaining assembly into the bearing of the shutter case (K20D-366) which has received a film of grease, AAF Specification No. 3560, soft grade. Then secure the trip coupling (K20B-409) to the trip shaft (K20B-408) with taper pin (F76-60-7). Add the shutter-cam stop pin (K20B-424) to the trip-actuating lever (K20B-406).

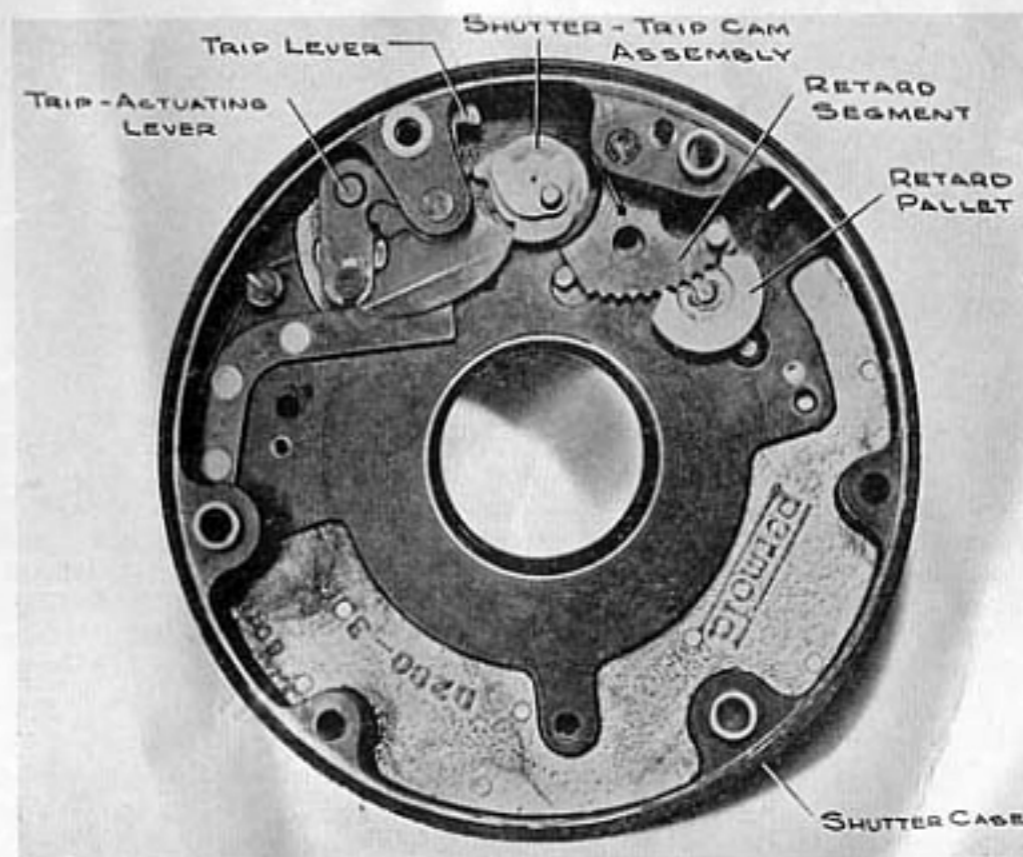

Figure 15—Shutter Case—Interior View

(5) To the upper plate (K20D-361) add the following: No. 1 leaf assembly (K20B-F26-1) and No. 1 pivot-shaft spacer (K20B-591), No. 2 leaf assembly (K20B-F26-2) and No. 2 pivot-shaft spacer (K20B-365), No. 3 leaf assembly (K20B-F26-3) and No. 3 pivot-shaft spacer (K20B-592), No. 4 leaf assembly (K20B-F26-4) and No. 4 pivot-shaft spacer (K20B-593), and finally the No. 5 link-drive leaf assembly (K20B-F25) and spacer (K20B-594). Before assembly, apply a small drop of oil, U. S. Army Specification No. 2-27 to the shutter-leaf pivots. Apply a small drop of oil, U. S. Army Specification No. 2-27, to the holes in the five connecting links (K20B-348), and position them on their proper connecting-link pins (K20B-354) to link the five shutter leaves (K20B-347) together. Secure the shutter-operating link (K20B-425) to the No. 5 link-drive leaf assembly (K20B-F25) with a washer (K20B-426) and an S-pin (K20B-524).

(6) Assemble the lower plate assembly (K20C-F37) and the four between-plates spacers (K20B-363) securing with two dowel pins (F79-3-10), four screws (AN500-4-5) and four lock washers (AN935-4). Before assembling the 12 diaphragm leaves (K20B-355), they are to be coated with oil, U. S. Army Specification No. 2-27. Care must be taken to remove as much of the oil as possible since non-removal will tend to buckle the leaves. Set the studs of the 12 diaphragm leaves (K20B-355) into the 12 equally-spaced holes in the lower plate assembly (K20C-F37). Position the diaphragm sector (K20C-356) on the lower plate assembly (K20C-F37), so that the 12 slots in it will fit over the studs of the 12 diaphragm leaves (K20B-355).

NOTE: When the index mark on the diaphragm sector (K20C-356) lines up with the index mark on the diaphragm-idler gear (K20B-357), the diaphragm must be at its full opening. The diaphragm sector (K20C-356) is positioned with three diaphragm-sector screws (K20B-364), which are held in place with shellac, Federal Specification No. TT-S-271.

(7) Position the leaf center assembly (K20D-F29) in the shutter case (K20D-366) and secure with two dowel pins (F79-3-10), three screws (500-6-5) and three lock washers (AN935-6). Secure the free end of the shutter-operating link (K20B-425) to the shutter-operating link pin (K20B-418) of the trip cam (K20B-419) with a washer (K20B-426) and an S-pin (K20B-524), keeping the bends in the same place (parallel to the top of the shutter case (K20D-366)). *Always use a new S-pin.*

(8) Turn the upper spring cup (K20B-370) in a counter-clockwise direction so that the shutter spring (K20B-530) will slip into the slot in the upper spring cup (K20B-370). Continue turning until another distinct click is heard and the upper spring cup (K20B-370) becomes latched. The initial tension of 45 degrees has now been put into the shutter spring (K20B-530). The full tension is 45 degrees plus one full turn, or 405 degrees.

(9) Insert the diaphragm-knob shaft assembly (K20B-F40) to which has been added a thin film of grease, AAF Specification No. 3560, soft grade, through the hole in the shutter-case cover (K20C-509). To the diaphragm-knob shaft assembly (K20B-F40) add the diaphragm-knob washer (K20B-527) and the diaphragm knob (K20B-582), which is secured with taper pin (F76-50-16). To the retard-cam assembly (K20B-F33) add the retard-disc assembly (K20B-F38), after depositing a small amount of grease, AAF Specification No. 3560,

soft grade, in the holes of the retard-cam stop disc (K20B-580). Then add the detent spacer (K20B-603). The retard-cam shaft (K20B-514) of the assembly is inserted through the shutter-case cover (K20C-509), and to the end of it the retard knob (K20B-515) is secured with a retaining clip (F78-3) and a taper pin (F76-50-16). The retard-cam stop spring (K20B-604) is secured to the shutter case cover (K20C-509) with two rivets (F67R-33). Add and secure the lens-locking eccentric (K20B-517) with lock washer (AN935-1L) and screw AN520C1-2).

(10) The shutter-case cover assembly (K20C-F36) is positioned on the shutter case (K20D-366) by means of a dowel pin (F79-4-10) and secured with three screws 500-8-6 and three lock washers (AN935-8). The two parts of the lens (K20C-344) are added and the lower half locked in position by means of the lens-locking eccentric (K20B-517). The three focusing posts (K20B-739) are then screwed into their proper places in the shutter assembly (K20E-F1).

5. Final Test.

The shutter speeds may be calibrated by use of a Type F-82 Shutter-Speed Testing Machine, as prescribed in T.O. No. 10-1-46.

The Folmer Graflex Corporation
Rochester, New York, U. S. A.

SECTION VIII
REPLACEMENT PARTS LIST

Part Number	Part Name
K20C-A7	Vacuum Back Assembly—Piston and Cylinder
K20B-A9	Roller Assembly—Film
K20B-A30	Pinning Assembly—Exposure-Counter Dial
K20B-A31	Viewfinder Assembly
K20B-A37	Shaft Assembly—Viewfinder
K20B-A40	Pin Assembly—Latch
K20D-H3	Plate Assembly—Side
K20B-H5	Arm Assembly—Counter-Actuating
K20B-H44	Ratchet Assembly—Take-Up Spool
K20C-H10	Handle Assembly—Operating
K20B-H11	Trigger Assembly
K20C-H16	Plate Assembly—Mechanism Rear
K20B-H18	Arm Assembly—Metering-Cam Follower
K20C-H21	Vacuum Back Assembly—Film Guide
K20B-H23	Roller Assembly—Film Metering
K20B-H24	Roller Assembly—Pressure
K20D-H25	Cone Assembly
K20D-H26	Cover Assembly—Camera
K20B-H27	Shaft Assembly—Wind-Coupling
K20B-H31	Plate Assembly—Recording
K20B-H34	Trap Assembly—Recording-Plate Light
K20B-23	Stop—Latch Pin
K20B-33	Screw—Trigger-Locking
K20B-41	Spring—Viewfinder
K20B-56	Stud—Actuating Link
K20C-H37	Bushing and Guide Assembly
K20B-76	Pivot—Piston-Actuating Lever
K20B-83	Pin—Retaining Roller
K20B-98	Lever—Piston-Actuating
K20B-A92	Sight—Viewfinder
K20B-143	Spring—Pressure Roller
K20B-154	Spacer—Operating Handle
K20B-182	Screw—Vacuum-Back Plate Locating
K20B-197	Link—Retainer
K20B-329	Shim—Latch Pin
K20B-337	Screw—Vacuum-Back Plate
K20B-447	Spring—Cam-Follower Arm Return

Part Number	Part Name
K20B-H28	Shaft Assembly—Trip-Coupling
K20B-449	Latch—Safety
K20B-458	Spring—Shutter-Wind Clutch
K20B-462	Washer
K20B-492	Spring—Film-Spool Holding Pawl
K20B-493	Pinion—Shutter-Wind Clutch
K20B-501	Wire—Trip-Link Securing
K20B-523	Pin
K20B-537	Rod—Supply-Spool Guide
K20B-540	Rod—Film Take-Up Spool Guide
K20B-550	Handle—Recording Plate
K20B-551	Plate—Recording
K20B-564	Spring—Piston-Actuating Lever
K20B-581	Retaining Link—Film Roll
K20B-587	Shim—Latch Pin
K20B-602	Rivet—Recording Plate
F6-44Rp	Screw
F22-D42	Screw—Set
F67R-2-4	Rivet
F78-3	Clip—Retaining
F78-5	Clip—Retaining
F79-4-12	Dowel Pin

TABLE OF INDEX NUMBERS

Index Number	Name	Part Number
1	Body
2	Cone	K20F-567
3	Hook—Camera-Support	K20B-213
4	Mount—Filter	K20B-G2
6	Clip—Spring
7	Viewfinder	K20B-A31
8	Frame—Viewfinder	K20B-105
9	Sight—Viewfinder	K20B-107
10	Spring—Leaf	K20B-209
11	Spring—Torsion	K20B-41
12	Shaft—Viewfinder	K20B-106
13	Guide—Film Loading	K20B-707
14	Handle—Rigid	K20B-567
15	Lens	K20D-344
16	Mount—Lens
17	Studs—Lens-Mount
18	Control—Diaphragm	K20B-F35
19	Cap—Lens
20	Cover—Magazine	K20E-570
21	Screw—Magazine Cover	K20B-39
22	Holder—Recording Plate	K20B-H34
23	Handle—Operating	K20D-541
24	Trigger	K20B-84
25	Plate—Pressure	K20D-543
26	Slot—Focal-Plane
27	Recorder	K20B-H31
28	Handle—Recorder	K20B-550
29	Plate—Recording	K20B-551
30	Shutter Assembly	K20E-F1
31	Knob—Retard (Speed Control)	K20B-515
33	Shaft—Take-Up Drive	K20B-H7
34	Knob—Take-Up	K20B-8
35	Spring—Take-Up Leaf	K20C-151
36	Plate—Supply-Spool Friction	K20B-A19
37	Spring—Supply Leaf	K20C-151
38	Roller—Guide	K20-A9
39	Roller—Film-Metering	K20B-H23
40	Roller—Pressure	K20B-55
41	Spool—Supply	K20B-B1
42	Spool—Take-Up	K20B-B1
43	Vacuum Back	K20C-A7
44	Piston—Vacuum	K20B-A39
45	Bracket—Wall	K20B-E187
46	Hooks—Wall Bracket
47	Slot—Wall Bracket
48	Spring—Wall Bracket	K20B-87
49	Counter—Exposure	K20B-A16