



Grandstream Networks, Inc.

DP715_US/DP710_US
IP DECT Phone



TABLE OF CONTENTS

DP715_US, DP710_US USER MANUAL

WELCOME	4
SAFETY COMPLIANCES	4
WARRANTY	4
INSTALLATION	5
EQUIPMENT PACKAGING	5
SETTING UP THE BASE STATION	5
SETTING UP THE CHARGING STATION	6
INSERTING THE BATTERIES IN A HANDSET	6
PRODUCT OVERVIEW	8
CONTROLS AND MENU STRUCTURE	10
KEYS/DISPLAYS/LEDS.....	10
DISPLAY (LCD).....	10
SYMBOLS	11
DISPLAY KEYS	11
MENU STRUCTURE	12
MENU OVERVIEW	12
HANDSET - SETTINGS AND OPERATION	13
TURNING THE HANDSET ON/OFF	13
REGISTERING A HANDSET TO THE DECT BASE STATION	13
“OUT OF RANGE” WARNING	13
COMPLETING CALLS	14
ANSWERING CALLS.....	15
CALL HISTORY:.....	15
THE PHONEBOOK.....	17
HANDSET FUNCTIONALITY	18
UNDERSTANDING DP715 VOICE PROMPT	22
DIRECT IP CALLS	23
CALL HOLD	24
CALL WAITING	24
CALL TRANSFER	24
3-WAY CONFERENCING	25
CALL FEATURES	25
BASE STATION - CONFIGURATION GUIDE	26
CONFIGURING THE DP715 BASE STATION THROUGH VOICE PROMPTS.....	26
CONFIGURING THE DP715 BASE STATION VIA WEB BROWSER.....	27
IMPORTANT SETTINGS	27
ADVANCED USER CONFIGURATION	30
SAVING THE CONFIGURATION CHANGES	39
REBOOTING THE DP715 BASE STATION FROM REMOTE	39
CONFIGURATION THROUGH A CENTRAL SERVER	39
SOFTWARE UPGRADE	40
FIRMWARE UPGRADE THROUGH TFTP/HTTP/HTTPS	40
INSTRUCTIONS FOR UPLOAD FROM LOCAL DIRECTORY:	41
INSTRUCTIONS FOR LOCAL FIRMWARE UPGRADE USING TFTP SERVER:	41
CONFIGURATION FILE DOWNLOAD	41

MANAGING FIRMWARE AND CONFIGURATION FILE DOWNLOAD.....	42
RESTORE FACTORY DEFAULT SETTING.....	42
BASE STATION	42
HANDSET	43

TABLE OF TABLES
DP715_US, DP710_US USER MANUAL

Table 1: Equipment Packaging.....	5
Table 2: Definitions of the DP71X Connectors	7
Table 3: Basic Definitions of the DP715 LEDs Pattern.....	7
Table 4: Advanced Definitions of the DP715 LEDs Pattern.....	7
Table 5: DP715 Feature Guide	8
Table 6: DP715 IVR Menu Definitions	22
Table 7: Basic Settings	28
Table 8: Status Page.....	30
Table 9: Advanced Settings	31
Table 10: Profile Settings	34
Table 11: DP715 Handsets Settings.....	38

CONFIGURATION GUI INTERFACE EXAMPLES

DP715_US, DP710_US USER MANUAL

http://www.grandstream.com/products/dp_series/dp71x/documents/dp715_gui.zip

1. SCREENSHOT OF ADVANCED USER CONFIGURATION PAGE
2. SCREENSHOT OF BASIC SETTINGS CONFIGURATION PAGE
3. SCREENSHOT OF HANDSET CONFIGURATION
4. SCREENSHOT OF PROFILE CONFIGURATION
5. SCREENSHOT OF STATUS PAGE
6. SCREENSHOT OF LOGIN PAGE
7. SCREENSHOT OF REBOOT PAGE
8. SCREENSHOT OF REBOOTING PAGE

WELCOME

Grandstream DP715_US, DP710_US is the next generation of powerful, affordable, high quality and simple to configure IP DECT Phone for small business, residential users and road warriors. Their compact size, superb voice quality, rich feature set, market leading price-performance and wide range radio coverage enable consumers to maximize the power of IP voice application and mobility for a minimum investment. The DP715_US, DP710_US is SIP and DECT compliant and field proven for flexible deployment.

This manual will help you learn how to operate and manage your IP DECT Phone DP715/710 and make the best use of its many upgraded features including simple and quick installation, 3-way conferencing, direct IP Calling, and new provisioning support among other features. The DP715/710 is very easy to manage and configure, and is specifically designed to be an easy to use and affordable VoIP solution for both the residential user and the teleworker.

SAFETY COMPLIANCES

The DP715_US, DP710_US phone complies with FCC/CE and various safety standards. The DP71X power adaptor is compliant with UL standard. Only use the universal power adapter provided with the DP71X package. The manufacturer's warranty does not cover damages to the phone caused by unsupported power adaptors.

WARRANTY

If you purchased your DP71X from a reseller, please contact the company where you purchased your device for replacement, repair or refund. If you purchased the product directly from Grandstream, contact your Grandstream Sales and Service Representative for a RMA (Return Materials Authorization) number before you return the product. Grandstream reserves the right to remedy warranty policy without prior notification.

Caution: *Changes or modifications to this product not expressly approved by Grandstream, or operation of this product in any way other than as detailed by this User Manual, could void your manufacturer warranty. Please do not use a different power adaptor with the DP71X as it may cause damage to the products and void the manufacturer warranty.*

- This document contains links to DP715_US GUI Interfaces. Please download these examples for your reference here:
http://www.grandstream.com/products/ht_series/ht70x/documents/dp71x_gui.zip
- This document is subject to change without notice. The latest electronic version of this user manual is available for download at:
http://www.grandstream.com/products/ht_series/ht70x/documents/dp71x_usermanual_english.pdf

Reproduction or transmittal of the entire or any part, in any form or by any means, electronic or print, for any purpose is not permitted without the express written permission of Grandstream Networks, Inc.

INSTALLATION

EQUIPMENT PACKAGING

Table 1: Equipment Packaging

	DP715_US	DP710_US
Base Station	Yes	No
Handset	Yes	Yes
Rechargeable batteries	2	2
Power Adaptor	Yes	Charger unit
Ethernet Cable	Yes	NO
Service Card	Yes	Yes
Quick Start Guide	Yes	Yes

SETTING UP THE BASE STATION

Carry out the following steps:

1. Plug the power supply plug into a 230V socket. Plug the connector into the connector socket on the underside of the base unit.
2. Connect the network socket on the underside of the base unit to the network connection socket using the Ethernet cable provided.

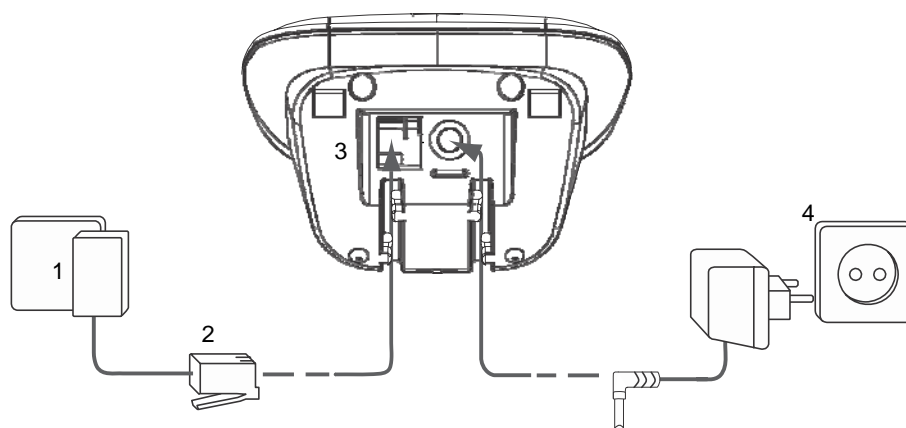

1. Network socket
2. Network cable
3. Underside of the base unit
4. Cable from the power supply plug

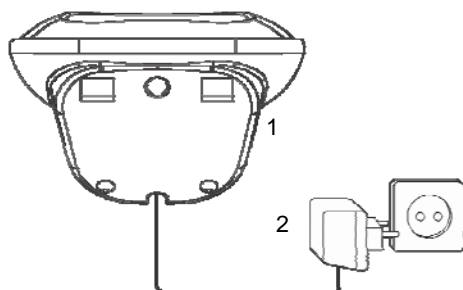

SETTING UP THE CHARGING STATION

Plug the power supply plug into a 230V socket to start using the charging unit.



1 Underside of the charging unit
2 Power supply plug

INSERTING THE BATTERIES IN A HANDSET

1. Open the battery compartment (see below).
2. Insert the batteries **in the correct polarity (+ and -)**.
3. Close the battery compartment.
4. To charge the rechargeable batteries for the first time, place the handset in the base unit or charging unit for 16 hours. The Charge/In use indicator (LED)   (15) on the base unit lights up.

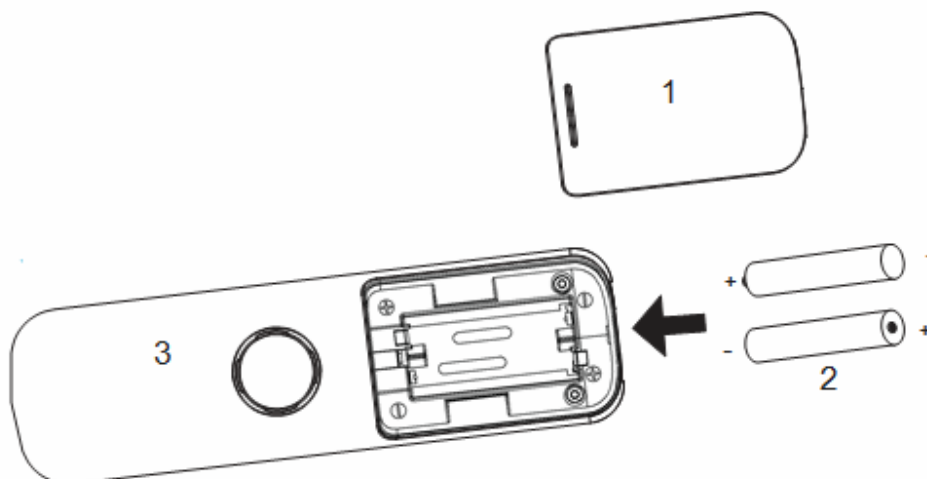

1. Battery compartment cover
2. Batteries
3. Rear of handset

Table 2: Definitions of the DP71X Connectors

DC 6V	Power adapter connection
LAN Port (RJ-45)	Connect to the internal LAN network. (DP715_US Only)
RESET	Factory Reset button: Press for 7 seconds to reset factory default settings. DP715_US Only)

There are four (4) LED buttons that help you manage the status of your DECT Base DP715.

Table 3: Basic Definitions of the DP715 LEDs Pattern

LEDs	
POWER LED	Indicates Power. Remains ON when power is connected
Network	Indicates Access to the Network. Remains ON while there is Access to the Network
Registered	Indicates if the accounts are registered
Call	Indicate status of active calls.

Table 4: Advanced Definitions of the DP715_US LEDs Pattern

Patten Number	Condition	LED	LED Behavior
LED-01	Device has normal power	Power	ON
LED-02	Power Error: Power is removed from the device or power supply with improper voltage is plugged in	Power	OFF
LED-03	Device has normal LAN connection and has obtained an IP address	Network	ON
LED-04	Link Down Note : This is the default state while the device is booting.	Network	Blink (1s on/ 1s off).
LED-05	Link Up but no IP Address	Network	Blink (.25s on/ .25s off)
LED-06	All configured SIP accounts are registered	Registered	ON
LED-07	SIP accounts are in the process of registering	Registered	Blink (1s on/ 1s off)
LED-08	Device is booting, application has not started.	Registered	Blink (.25s on/ .25s off)
LED-09	Registration Error - ANY SIP account experiences registration failure.	Registered	0.25sec ON/ 0.25sec OFF
LED-10	Call is active. Any DECT handset is in an active call with an external line.	Call	ON
LED-11	No active call.	Call	OFF

PRODUCT OVERVIEW

The DP715_US, DP710_US is the next generation of powerful, affordable, high quality and simple to configure IP DECT Phone for small business, residential users and road warriors. Their compact size, superb voice quality, rich feature set, market leading price-performance and wide range radio coverage enable consumers to maximize the power of IP voice application and mobility for a minimum investment. The VoIP network signaling protocol supported is SIP. The DP715/710 is fully compatible with SIP industry standard and can interoperate with many other SIP compliant devices and software on the market. Moreover, it supports comprehensive voice codecs including G.711, G.723.1, G.729A/B, G.726 and iLBC.

Table 5: DP715 Feature Guide

	DP715_US	DP710_US
Interfaces		
Air Interface	Telephony standards: DECT / GAP Frequency range: 1880 MHz to 1900 MHz Number of channels: 120 duplex channels Modulation: GFSK Speech coding: 32 kbit/s Emission power: 10 mW (average power per channel) Range: up to 300 m outdoors, maximum of 50 m in buildings	
Network Interface	One 10/100Mbps auto-sensing Ethernet port (RJ45)	
LED Indicators	POWER NETWORK REGISTERED CALL	128*128 LCD with blue color backlight
Factory Reset Button	Yes	
Audio Interface		2.5mm headset
Voice		
Voice over Packet Capabilities	Dynamic Jitter Buffer	Speakerphone with Acoustic Echo Cancellation,
Voice Compression	G.711 with Annex I (PLC) and Annex II (VAD/CNG), G.723.1, G.726-32 AAL2, G.729A/B, iLBC	
Telephony Features	Caller ID display or block, call waiting, Flash, blind or attended transfer, forward, hold, do not disturb, 3-way conference	
QoS	Layer 2 (802.1Q VLAN/802.1p), Layer 3 (ToS, DiffServ, MPLS)	
IP Transport	RTP/RTCP	
Signaling		
DTMF Method	In-audio, RFC2833 and/or SIP Info	
IP Signaling	SIP (RFC 3261)	
Multiple SIP accounts per base station	Up to five (5) distinct SIP accounts per system Independent SIP account per handset Multiple handsets per SIP account	
Provisioning	HTTP, HTTPS, TELNET, TFTP, TR-069 (pending), secure and automated provisioning, syslog	
Security		

Media	SRTP	
Control	TLS/SIPS	
Management	Syslog support, telnet, remote management using Web browser	
Physical		
Universal Power Supply	Input: 100-240VAC 50-60Hz 0.15A Output: 6VDC/500mA	Input: 100-240VAC 50-60Hz 0.15A Output: 7VDC/420mA
Power Consumption & Battery Life	Base unit with handset: approximately 1.4 W	10 hours talk time 100 hours standby time 16 hours charging time
Dimensions (H x W x D)	Base Unit: 75 x 105 x 85 mm	Handset: 161 x 46 x 22 mm Charging station: 53 x 75 x 60 mm
Weight	Base unit including power supply plug: 173 g	Handset including 2 batteries: 107 g Charging station including power supply plug: 101 g
Environmental	Operational: 5° – 45°C Storage: 0° – 60°C Humidity: Maximum 70% Non-condensing	
Additional Features		
Phonebook		200 numbers (up to 24 digits long) with an associated name (up to 16 characters long) 10 outgoing call entries 30 incoming call entries
Homologation		
Safety	CENELEC EN 60950-1:2006 / All:2009	
EMC	ETSI EN 301 489-1 V1.8.1 ETSI EN 301 489-6 V1.3.1	
Efficient use of Frequency Spectrum	ETSI EN 301 406 V1.5.1	
Health	CENELEC EN 50360:2001-07 CENELEC EN 50385:2002-08 Directive 2009/125/EC (EuP) Regulation 278/2009	

CONTROLS AND MENU STRUCTURE

KEYS/DISPLAYS/LEDS

Handset

1. Display
2. Right display button (display functions)
3. Up/Redial key
4. Right/Recall key
5. On-hook/On-off-key
6. Alphanumeric keypad
7. Keypad lock key
8. Dial pause key
9. Microphone
10. Ringer off-key
11. Down/Calls list key
12. Off-hook key/Handsfree key
13. Left/Internal call key
14. Left display button (display functions)

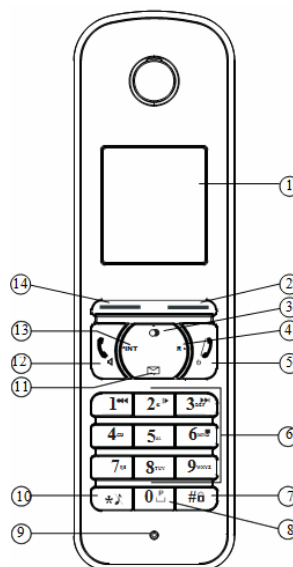

Base station

15. Charge/In use indicator (LED)

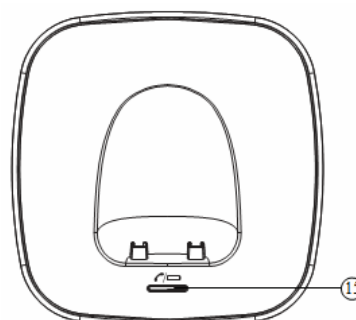

DISPLAY (LCD)



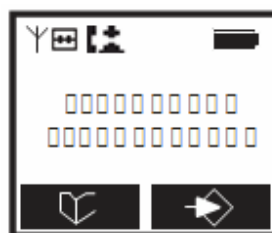





- Icon line →
- Text line →
- Display menu/options menu →



Battery display:

- The batteries are fully charged.
- The batteries are 75% charged.
- The batteries are half charged (50%).
- The batteries are only 25% charged.
- The batteries are almost flat. The battery icon in the display flashes and the "Battery Low!" message appears.

SYMBOLS

Icon	LCD Icon Definitions
	On Hook.
	Off Hook.
	Ringing.
	Internal Call.
	Handsfree Speaker ON.
	Keypad Locked.
ABC	Upper Case.
Abc	Lower Case.
	Direction to further menu items.
	Call list entries.
	New voicemail message.
	Handset ringer off.
	Alarm set.
	Aerial icon: in range (steady) - out of range (flashing)

DISPLAY KEYS

The display keys are the keys immediately below the display: ② and ⑭. Their function changes depending on the current context. Their current function is shown directly above in the display. The most important display key functions are:

	Phone book		Mute function
	OK/Confirm		Previous
	Menu		Cancel
	Delete		

MENU STRUCTURE

The handset has an easy-to-use menu structure. Every menu opens a list of options.

To open the main menu, press the right display key when the handset is on and in standby mode. ➔ ②

Press the ▲ ③ key or ▼ ⑪ key to scroll to the menu option you require. The instructions in this user guide show the key symbols and the item number on the device overview. Then press  ⑫ to select further options or confirm the setting displayed.



Exit menu or go up a menu level

To go to the previous menu item, press  ⑭.



You can press the  ⑮ key at any time to cancel and return to standby mode. If you do not press any key, the handset automatically reverts to standby mode after 20 seconds.

MENU OVERVIEW

Menu	Submenu items
Phonebook	
Handset	Ring Tone Ringer Volume Handset Name Keypad Beep Contrast Auto Talk Select Base Language Registration
Time	Set Alarm Set Time Format
Tools	Appointment Stop Watch

HANDSET - SETTINGS AND OPERATION

TURNING THE HANDSET ON/OFF













1. Press the off-button  ⑤ to turn the handset on.
2. To switch the handset off, press and hold the off-key  ⑤ until the handset switches off.

REGISTERING A HANDSET TO THE DECT BASE STATION

Up to 5 handsets can be registered to one base station. Each handset can, for its part, be registered to up to four base units and the user can choose which base unit he wishes to use. In the default setting as supplied, each handset is registered as Handset 1 to Base unit 1.

1. The base station has to be restarted or you must enable the Subscription mode on it. Unplug the base station power supply and plug it back in again or enable the Subscription mode.



Registration mode on the base unit is now activated for approximately 2 minutes. You must work through the following steps to register a handset:

2. Press  ② .
3. Press  ③ or  ⑪ repeatedly, select **Handset**
4. Press  ② to confirm.
5. Press  ③ or  ⑪ repeatedly, select **Registration**.
6. Press  ② to confirm.
7. Select '**Register**' and press  ② .
8. Select the base unit (1-4) desired using  ③ or  ⑪ and press  ② .
9. Enter the base unit PIN (System PIN; default: 0000) and press  ② .
10. Restart base appears in the display.
11. The handset will now search for the base unit and register when it has found it. The display shows standby mode after a successful registration and the handset name and handset number appear.

Note: It is not possible to make or receive calls while the base unit is in registration mode.

“OUT OF RANGE” WARNING





When the handset is out of range of the base unit during communication:

- Searching appears in the display and the  icon flashes in the display.
- Move closer to the base unit.
- The  no longer flashes and is shown steadily.
- You are back within the base unit's range.

COMPLETING CALLS

There are five ways to complete a call:

A. Make an External call



1. Press   **12**
2. The Charge/In use indicator (LED)  **15** on the base unit flashes and the call icon  appears in the display.
3. Dial the number you want once you hear the dialing tone.
4. The number appears on the display and is dialed.
5. To finish the call, press  **5** or replace the handset in the base unit or the handset charging unit.

B. Making an internal call





1. Press INT.
2. Internal appears in the display.
3. Select the number of the handset (keys 1-5) you wish to call.
4. When you have completed your call, press  **5** to hang up.

Note : Both DP710 should be registered to the same DP715 Base station.

C. Redialing the last number dialed

1. Press  **3**
2. Press   **12**
- The number you last called will be dialed automatically.





D. Redialing one of the last 10 numbers called



1. Press  **3**
2. The number you have most recently called appears in first place in the display.
3. Use  **3** or  **11** to search for the number you need.
4. Press   **12**

5. The number shown in the display is dialed automatically.
6. To finish the call, press  **5** or replace the handset in the base unit or the handset charging unit.

E. Calling a number from the phonebook

The phone has a phonebook in which you can save numbers and names
To call a number from the phonebook:

1. Press  **14**
2. The first number in the phonebook appears on the display.
3. Press  **3** or  **11** to browse the phonebook.
4. Press   **12** .







5. The number shown in the display is dialed automatically.
6. To finish the call, press   or replace the handset in the base unit or the handset charging unit.

ANSWERING CALLS

There are 2 ways to answer calls:

















A. Answer a call from the handset manually

The handset starts to ring during an incoming external or internal call. You can switch off the ringer temporarily by pressing Silent.

1. The call symbol  appears in the display.
2. The caller's number appears in the display. The name of the caller also appears on the display if:
 - a. The number is programmed into the phonebook with name.
 - b. The network transmits the name along with the phone number.
3. You have the following options for answering a call:
 - a. Press   to pick up the call.
 - b. Pick up the handset from the base unit or from the handset charging unit (function only possible if Auto Talk has been activated).
4. During the call, the  icon, the caller's number or the name and call duration are shown on the display as well.
5. To finish the call, press   or replace the handset in the base unit or the handset charging unit.





B. Auto Talk Mode

If the handset is in the base unit and an incoming call is received, the call will be picked up automatically by picking the handset up from the base unit. You can choose whether this function should be enabled or not.





1. Press  .
2. Press   or   repeatedly, select **Handset**.
3. Press   to confirm.
4. Press   or   repeatedly, select **Auto Talk**.
5. Press   to confirm.
6. Select **On** or **Off** and press   to confirm.

CALL HISTORY:

When you receive a call, the phone number of the caller, the date and time appear in the handset display. The name will also be shown if it is in the phonebook or present in the SIP Invite.

The calls received are stored in a calls list (maximum of 30 call entries are saved). When the memory is full, the new calls automatically replace the oldest ones in the log. The upper icon in the display  flashes if there are new missed calls in the calls list, and the number of new calls is shown in the middle of the display next to the  icon. If the calls list is empty and you press  , Calls List Empty appears.









Consult the call history

1. Press   to retrieve the most recent entry.
2. The phone number of the most recent caller appears. If the caller's name is entered in the phonebook, the name will be shown in the first line. If there is no entry and the calling number is not transmitted Withheld is shown.
The date and time for each call show when the call was received in the second and third line.
The following information is also displayed in the third or fourth line:
 - **New:** Unread or unanswered call.
 - **Old:** Read or answered call.
 - **Repeat:** Multiple calls of the same number. Only the last call is shown.
3. Press   to display further entries in the list.













NOTE: If you do not press either of the   or   keys for 20 seconds the telephone will revert back to standby mode.

After a call, the number of the caller remains on the display for about 4 seconds after the last ring.









Calling a number from the Call HISTORY

1. Press   to access the calls history.
2. Use   or   to search for the number you need.
3. When the number is shown in the display, press   .
4. The number will be dialed automatically.

Deleting a call

1. Press   to access the calls list.
2. Use   or   to search for the number you need.
3. Press Option .
4. Press   or   repeatedly, select **Delete**.
5. Press   to confirm.
6. The call is deleted and the next call appears on the display.

Delete all calls







1. Press   to access the calls list.
2. Press Option .
3. Press   or   repeatedly, select **Delete ALL**.
4. Press   to confirm.
5. All calls are deleted.

Note: Only the old calls are deleted. New calls, i.e. calls that have not been read or answered, are retained.









THE PHONEBOOK

You can store 200 numbers (up to 24 digits long) with an associated name (up to 16 characters long) in the phonebook.

















Saving a new entry in the phonebook

1. Press  .
2. Press **Option** and confirm the New Entry with   to add a new entry.
 - **Name:** appears in the display.
3. Enter the name using the alphanumeric keys.
4. Press **Save** and enter the phone number.
5. Press **Save** and select the ringer melody required.
6. Press **Save**, to save the entry to the phonebook or press   to cancel without saving the entry.







Finding and calling a number from the phonebook



1. Press  .
2. Enter the initial letter of the name using the alphanumeric keys.
3. The first name in the list with this letter appears in the display.
4. Press   or   repeatedly to scroll through the other numbers in the phonebook.
5. Calling a listed person: the phone number required is highlighted. Press  .

Edit a phonebook entry





1. Press  .
2. Enter the initial letter of the name using the alphanumeric keys.
3. The first name in the list with this letter appears in the display.
4. Press   or   repeatedly to scroll through the other numbers in the phonebook.
5. Once the number you require appears in the display and is highlighted, press **Option**.
6. Press   or   repeatedly and select **Edit Entry**.
7. Press   to confirm.
8. Press   to delete each letter individually and use the alphanumeric keys to enter the correct name.
9. Press **Save**.
10. Press   to delete each individual digit and use the alphanumeric keys to enter the correct phone number.
11. Press **Save** and select the ringer melody you require.
12. Press **Save** to save the changes entered.

Delete an entry or all entries

1. Press  .
2. Enter the initial letter of the name required using the alphanumeric keys and/or scroll to the entry required.
3. Press **Option**.
4. Scroll with   or   to **Delete Entry?** to delete the current entry only.
5. Or **Delete All** to delete all entries.

6. Press  2.
7. Press  2 again to confirm or  14 to cancel without deleting.











Display the details of phonebook entries

1. Press  14.
2. Enter the initial letter of the name required using the alphanumeric keys and/or scroll to the entry required.
3. Press **Option**.
4. Scroll with  3 or  11 to Show Details and press  2.
5. The name, phone number and ringer melody you have assigned to the entry appear in the display.
6. Press  14 to return to the list of entries.

HANDSET FUNCTIONALITY





Selecting the menu language



The telephone has a number of menu languages, see the packaging. Proceed as follows to set the language:

1. Press  2.
2. Scroll with  3 and  11 to handset and press  2 to confirm.
3. Scroll with  3 and  11 to Language and press  2 to confirm. The language settings will appear on the display.
4. Scroll with  3 and  11 to the required language and press  2 to confirm.
5. You will hear a beep to confirm and the display will show: **Saved**.
6. Or press  14 to quit the menu without saving the setting.

Activate/deactivate handsfree mode



This function allows you to make a call without having to hold the handset in your hand.

1. Press   12 while you are making a call to activate handsfree mode.
2. Press   12 again to deactivate the handsfree function.

Note: If you are calling in handsfree mode and wish to change the volume press  3 or  11 several times.

Important: The batteries will be drained more quickly if you use the handsfree function for some time.

Setting the loudspeaker volume

Press  3 or  11 while you are making a call to set the volume of the loudspeaker. You can choose between 5 different settings. The default setting is level 3:

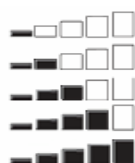

- Volume 1
- Volume 2
- Volume 3
- Volume 4
- Volume 5

Note: The volume is adjusted in the same way in handsfree mode.

Muting the microphone











Press the  (2) display key to switch off the microphone during a call. You can now talk freely without the caller on the telephone hearing you. Press Off (2) again to switch the microphone back on.

Setting the ringer volume on the handset

You can adjust the ringer volume for an incoming call (internal or external) to one of 6 levels (level 1 to 5 and off).

If you select **Off**, the  icon appears in the display. The handset will not ring for an incoming call. Level 5 is the highest level. (The telephone is set to level 3 by default).

In order to configure the desired ringer volume, proceed as follows:

1. Press  (2).
2. Press  (3) or  (11) repeatedly, select Handset.
3. Press  (2) to confirm.
4. Press  (3) or  (11) repeatedly, select Ringer Volume.
5. Press  (2) to confirm.
6. The current volume is displayed and can be heard.
7. Press  (3) or  (11) repeatedly to set the desired volume.
8. Press Save (2) to confirm your selection or press  (14) to quit the menu without saving the setting.











Setting the ringer melody on the handset

You can change the ringer melody for an incoming call (internal or external). The device has 18 different ringer melodies for you to choose from (1-18).

The default setting for the ring tone for an external call is melody 10.

The default setting for the ring tone for an internal call is melody 1.







In order to configure the desired melody for either an internal/external call, proceed as follows:

1. Press  (2).
2. Press  (3) or  (11) repeatedly, select Handset.
3. Press  (2) to confirm.
4. Press  (3) or  (11) repeatedly, select Ring Tone.
5. Press  (2) to confirm.
6. Select External or Internal and press  (2).
7. The current melody is displayed and can be heard.
8. Press  (3) or  (11) repeatedly, to select the desired melody.
7. Press Save (2) to confirm your selection, or press  (14) to quit the menu without saving the setting.

Setting the key lock



















You can lock the keypad against unintentional entries. It is, however, still possible to pick up incoming calls even with the keypad locked.

Enabling or disabling the keypad lock:























1. Enable: press #   and hold for approximately 2 seconds.
2. The display shows Keypad Locked briefly and the key lock icon  appears in the display.
3. Disable: press Unlock, , then #   to unlock the keys again.
4. Keypad Unlocked appears briefly in the display.

Keypad beep on/off

You can set the handset so that a beep is heard every time a key is pressed.

















1. Press  .
2. Press   or   repeatedly, select Handset.
3. Press   to confirm.
4. Press   or   repeatedly, select Keypad Beep.
5. Press   to confirm.
6. Select
 - **On:** switches keypad beep on.
 - **Off:** switches keypad beep off.
7. Press   to confirm your selection or press   to quit the menu without saving the setting.

Adjust the display contrast









1. Press  .
2. Press   or   repeatedly, select Handset.
3. Press   to confirm.
4. Press   or   repeatedly, select Contrast.
5. Press   to confirm.
6. Select the contrast (8 contrast levels) using   or  .
7. Press   to confirm your selection or press   to quit the menu.

Edit handset name

The procedure for changing the name of your handset shown in the display in standby mode is as follows:



1. Press  .
2. Press   or   repeatedly, select Handset.
3. Press   to confirm.
4. Press   or   repeatedly, select Handset Name.
5. Press   to confirm.
6. Press   repeatedly to delete the letters one after the other and use the alphanumeric keys to enter a new name.
7. Press Save  to set the new handset name.

Setting an alarm

1. Press  ②.
2. Press  ③ or  ⑪ repeatedly, select **Time**.
3. Press  ② to confirm.
4. Press  ③ or  ⑪ repeatedly, select **Set Alarm**.
5. Press  ② to confirm.
6. Press  ③ or  ⑪ repeatedly and select one of the four possible settings:
 - ✓ Once,
 - ✓ Every Day,
 - ✓ Mon to Fri
 - ✓ Off.

Confirm with  ② . When you select Once, Every Day or Mon to Fri, the display shows:

Time (24hr):
07:00















7. Enter the alarm time required using four digits and press Save.
8. Press  ③ or  ⑪ repeatedly and select one of the 18 possible alarm melodies and press Save .
9. Select Off to turn off the alarm function. Confirm with  ②.

Switching the alarm off



1. Switch the alarm off when it sounds by pressing **Stop** .
2. Press **Snooze** to repeat the alarm function 5 minutes later.

Appointments

You can set five appointments or reminders to which you can assign a name and an alarm by date and time.

1. Press  ②.
2. Press  ③ or  ⑪ repeatedly, select **Tools**.
3. The Appointment menu item is already highlighted. Press  ②.
4. Scroll with  ③ or  ⑪ to one of the five appointments and press  ②.
5. Using  ③ or  ⑪ and then  ② select from the following options:
 - a. Edit to edit the settings for the appointment. Edit the name of the appointment and press Save. Enter the date for the appointment and press Save. Enter the time and press Save. Using  ③ or  ⑪ select the alarm melody required (18 melodies) and press Save.
 - b. Delete to delete the selected appointment. Press  ② to confirm or  ⑭ to cancel.
6. Switch the appointment reminder off when it sounds by pressing  ⑭.

Stop watch

1. Press  ②.
2. Scroll with ▲ ③ to Tools and press  ②.
3. Scroll with ▲ ③ or ▼ ① to Stop Watch and press  ②.
4. Press **Start**, to start the watch.
5. Press **Stop**, to stop the watch.
6. Press **Start** again to allow the stop watch to continue to run.
7. Press **Reset** to reset the stop watch to **00:00**.

UNDERSTANDING DP715 VOICE PROMPT

DP715 has a built-in voice prompt menu for simple device configuration. The IVR menu and the LED button work with any of the Handset. Pick up the handset and dial “***” to use the IVR menu.

Table 6: DP715_US IVR Menu Definitions

Menu	Voice Prompt	Options
Main Menu	“Enter a Menu Option”	Press “*” for the next menu option Press “#” to return to the main menu Enter 01-05, 07,10, 13-17,47 or 99 menu options
01	“DHCP Mode”, “Static IP Mode”	Press “9” to toggle the selection If using “ <i>Static IP Mode</i> ”, configure the IP address information using menus 02 to 05. If using “ <i>Dynamic IP Mode</i> ”, all IP address information comes from the DHCP server automatically after reboot.
02	“IP Address “ + IP address	The current WAN IP address is announced If using “ <i>Static IP Mode</i> ”, enter 12 digit new IP address. You need to reset the DP715 for the new IP address to take Effect.
03	“Subnet “ + IP address	Same as menu 02
04	“Gateway “ + IP address	Same as menu 02
05	“DNS Server “ + IP address	Same as menu 02
07	Preferred Vocoder	Press “9” to move to the next selection in the list: <ul style="list-style-type: none"> • PCM U / PCM A • iLBC • G-726 • G-723 • G-729
10	“MAC Address”	Announces the Mac address of the unit.
13	Firmware Server IP Address	Announces current Firmware Server IP address. Enter 12 digit new IP address.
14	Configuration Server IP Address	Announces current Config Server Path IP address. Enter 12 digit new IP address.
15	Upgrade Protocol	Upgrade protocol for firmware and configuration update. Press “9” to toggle between TFTP / HTTP / HTTPS
16	Firmware Version	Firmware version information.
17	Firmware Upgrade	Firmware upgrade mode. Press “9” to toggle among the following three options:

		- always check - check when pre/suffix changes - never upgrade
18	Subscription Mode	Press "9" to toggle subscription mode on the base. Subscription mode is automatically exited after 120 seconds.
47	"Direct IP Calling"	Enter the target IP address to make a direct IP call, after dial tone. (See "Make a Direct IP Call".)
86	Voice Mail	Number of Voice Mails
99	"RESET"	Press "9" to reboot the device Enter MAC address to restore factory default setting (See Restore Factory Default Setting section)
	"Invalid Entry"	Automatically returns to main menu
	"Device not registered"	This prompt will be played immediately after off hook If the device is not register and the option "Outgoing Call without Registration" is in NO

Five Success Tips when using the Voice Prompt

1. "*" shifts down to the next menu option
2. "#" returns to the main menu
3. "9" functions as the ENTER key in many cases to confirm or toggle an option
4. All entered digit sequences have known lengths - 2 digits for menu option and 12 digits for IP address. For IP address, add **0** before the digits if the digits are less than 3 (i.e. - 192.168.0.26 should be key in like 192168**0000**26. No decimal is needed).
5. Key entry cannot be deleted but the phone may prompt error once it is detected

Call Features

DIRECT IP CALLS



Direct IP calling allows two parties, that is, a Handset and another VoIP Device, to talk to each other in an ad hoc fashion without a SIP proxy.

Elements necessary to complete a Direct IP Call:



1. Both DP715_US, and other VoIP Device, have public IP addresses, or
2. Both DP715_US and other VoIP Device are on the same LAN using private IP addresses, or
3. Both DP715_US and other VoIP Device can be connected through a router using public or private IP addresses (with necessary port forwarding or DMZ).

DP715 supports two ways to make Direct IP Calling:

Using IVR

1. Pick up the Handset and press    then access the voice menu prompt by dial "****"
2. Dial "47" to access the direct IP call menu
3. Enter the IP address after the dial tone and voice prompt "Direct IP Calling"

Using Star Code

1. Pick up the Handset and press    then dial “*47”
2. Enter the target IP address.

Note: NO dial tone will be played between step 1 and 2.

Examples of Direct IP Calls:

- a) If the target IP address is 192.168.0.160, the dialing convention is ***47 or Voice Prompt with option 47, then 192*168*0*160.** followed by pressing the “#” key if it is configured as a send key or wait 4 seconds. In this case, the default destination port 5060 is used if no port is specified.
- b) If the target IP address/port is 192.168.1.20:5062, then the dialing convention would be: ***47 or Voice Prompt with option 47, then 192*168*0*160*5062** followed by pressing the “#” key if it is configured as a send key or wait for 4 seconds.

NOTE: When completing direct IP call, the “Use Random Port” should set to “NO”. You cannot make direct IP calls between Handsets since they are using same IP.

CALL HOLD

Place a call on hold by pressing the “Recall” button on the Handset. Press the “Recall” button again to release the previously held Caller and resume conversation.

CALL WAITING

Call waiting tone (3 short beeps) indicates an incoming call, if the call waiting feature is enabled. Toggle between incoming call and current call by pressing the “Recall” button. First call is placed on hold. Press the “Recall” button to toggle between two active calls.

CALL TRANSFER

Blind Transfer

Assume that call Caller A and B are in conversation. A wants to *Blind Transfer* B to C:

1. Caller A presses **RECALL** on the Handset to hear the dial tone.
2. Caller A dials ***87** then dials caller C’s number, and then # (or wait for 4 seconds)
3. Caller A will hear the confirm tone. Then, A can hang up.

NOTE: “Enable Call Feature” must be set to “Yes” in web configuration page.

Caller A can place a call on hold and wait for one of three situations:

- a. A quick confirmation tone (similar to call waiting tone) followed by a dial-tone: This indicates the transfer is successful (transferee has received a 200 OK from transfer target). At this point, Caller A can either hang up or make another call.
- b. A quick busy tone followed by a restored call (on supported platforms only): This means the transferee has received a 4xx response for the INVITE and we will try to recover the call. The busy tone is just to indicate to the transferor that the transfer has failed.
- c. Continuous busy tone: The phone has timed out.

Note: continuous busy tone does not indicate the transfer has been successful, nor does it indicate the transfer has failed. It often means there was a failure to receive second NOTIFY – check firmware for most recent release.

Attended Transfer

Assume that Caller A and B are in conversation. Caller A wants to *Attend Transfer* B to C:

1. Caller A presses **RECALL** on the Handset for dial tone.
2. Caller A then dials Caller C's number followed by # (or wait for 4 seconds).
3. If Caller C answers the call, Caller A and Caller C are in conversation. Then A can hang up to complete transfer.
4. If Caller C does not answer the call, Caller A can press "flash" to resume call with Caller B.

NOTE: When Attended Transfer fails and A hangs up, the DP715 will ring back user A to remind A that B is still on the call. A can pick up the phone to resume conversation with B.

3-WAY CONFERENCING

The DP715 supports Bellcore style 3-way Conference.

Instructions for 3-way conference:

Assume that call party A and B are in conversation. Caller A (DP71X) wants to bring third Caller C into conference:

1. A presses RECALL (on the Handset) to get a dial tone.
2. A dials C's number then # (or wait for 4 seconds).
3. If C answers the call, then A presses RECALL to bring B, C in the conference.
4. If C does not answer the call, A can press RECALL back to talk to B.
5. If A presses RECALL during conference, C will be dropped out.
6. If A hangs up, the conference will be terminated for all three parties when configuration "Transfer on Conference Hang up" is set to "No". If the configuration is set to "Yes", A will transfer B to C so that B and C can continue the conversation.

CALL FEATURES

The DP715 supports all the traditional and advanced telephony features.

Key	Call Features
*02	Forcing a Codec (per call) *027110 (PCMU), *027111 (PCMA), *02723 (G723), *02729 (G729), *0272616 (G726-r16), *0272624 (G724-r24), *0272632 (G726-r32), *0272640 (G726-r40), *027201 (iLBC)
*16	Enable SRTP
*17	Disable SRTP
*30	Block Caller ID (for all subsequent calls)
*31	Send Caller ID (for all subsequent calls)
*47	Direct IP Calling. Dial "**47" + "IP address". No dial tone is played in the middle. Detail see Direct IP Calling section on page 12.

*50	Disable Call Waiting (for all subsequent calls)
*51	Enable Call Waiting (for all subsequent calls)
*67	Block Caller ID (per call). Dial “*67” + ” number “. No dial tone is played in the middle.
*82	Send Caller ID (per call). Dial “*82” + ” number “. No dial tone is played in the middle.
*69	Call Return Service: Dial *69 and the phone will dial the last incoming phone number received.
*70	Disable Call Waiting (per call). Dial “*70” + ” number “. No dial tone is played in the middle.
*71	Enable Call Waiting (per call). Dial “*71” + ” number “. No dial tone is played in the middle.
*72	Unconditional Call Forward: Dial “*72” and then the forwarding number followed by “#”. Wait for dial tone and hang up. (dial tone indicates successful forward)
*73	Cancel Unconditional Call Forward. To cancel “Unconditional Call Forward”, dial “*73”, wait for dial tone, then hang up.
*74	Enable Paging Call: Dial “*74” and then the destination phone number you want to page.
*78	Enable Do Not Disturb (DND): When enabled all incoming calls are rejected.
*79	Disable Do Not Disturb (DND): When disabled, incoming calls are accepted.
*87	Blind Transfer
*90	Busy Call Forward: Dial “*90” and then the forwarding number followed by “#”. Wait for dial tone then hang up.
*91	Cancel Busy Call Forward. To cancel “Busy Call Forward”, dial “*91”, wait for dial tone, then hang up.
*92	Delayed Call Forward. Dial “*92” and then the forwarding number followed by “#”. Wait for dial tone then hang up.
*93	Cancel Delayed Call Forward. To cancel Delayed Call Forward, dial “*93”, wait for dial tone, then hang up.
Flash/Hook (Recall)	Toggles between active call and incoming call (call waiting tone). If not in conversation, flash/hook will switch to a new channel for a new call.
#	Pressing pound sign will serve as Re-Dial key.

BASE STATION - CONFIGURATION GUIDE

CONFIGURING THE BASE STATION THROUGH VOICE PROMPTS

DHCP MODE

Select voice menu option 01 to enable DP715 to use DHCP.

STATIC IP MODE

Select voice menu option 01 to enable DP715 to use STATIC IP mode, then use option 02, 03, 04, 05 to set up IP address, Subnet Mask, Gateway and DNS server respectively.

FIRMWARE SERVER IP ADDRESS

Select voice menu option 13 to configure the IP address of the firmware server.

CONFIGURATION SERVER IP ADDRESS

Select voice menu option 14 to configure the IP address of the configuration server.

UPGRADE PROTOCOL

Select voice menu option 15 to choose firmware and configuration upgrade protocol. User can choose between TFTP and HTTP.

FIRMWARE UPGRADE MODE

Select voice menu option 17 to choose firmware upgrade mode among the following three options:

1) Always check, 2) check when pre/suffix changes, and 3) never upgrade.

CONFIGURING THE BASE STATION VIA WEB BROWSER

DP715 Base Station has an embedded Web server that will respond to HTTP GET/POST requests. It also has embedded HTML pages that allow users to configure the DP715 through a web browser such as Microsoft's IE, AOL's Netscape or Mozilla Firefox installed on Windows or Unix OS. (Macintosh OS is not included).

Access the Web Configuration Menu

1. Find the IP address of the Base Station using voice prompt menu option 02.
2. Open a web browser, type in the IP address. You will see the login page of the device.

Note: The IVR announces 12 digits IP address, you need to strip out the leading "0" in the IP address. For ex. IP address: 192.168.001.014, you need to type in <http://192.168.1.14> in the web browser.

Once the HTTP request is entered and sent from a web browser, the user will see a login screen. There are two default passwords for the login page:

User Level:	Password:	Web pages allowed:
End User Level	123	Only Status and Basic Settings
Administrator Level	admin	Browse all pages

The password is case sensitive with maximum length of 25 characters. The factory default password for End User and administrator is "123" and "admin" respectively. Only an administrator can access the "ADVANCED SETTING", "Handset Settings" configuration pages. Please reference the GUI pages using the following link: http://www.grandstream.com/products/dp_series/DP71x/documents/DP71x_gui.zip.

NOTE: If you **cannot** log into the configuration page by using the default password, please check with the VoIP service provider. It is most likely the VoIP service provider has provisioned the device and configured for you therefore the password has already been changed.

IMPORTANT SETTINGS

The end-user must configure the following settings according to the local environment.

NOTE: Most settings on the web configuration pages are set to the default values.

NAT Settings

If you plan to keep the DECT phone within a *private network* behind a firewall, we recommend using STUN Server. The following three (3) settings are useful in the STUN Server scenario:

1. **STUN Server** (under Advanced Settings webpage)
Enter a STUN Server IP (or FQDN) that you may have, or look up a free public STUN Server on the internet and enter it on this field. If using Public IP, keep this field blank.
2. **Use Random Ports** (under Advanced Settings webpage)
This setting depends on your network settings. Generally if you have multiple IP devices under the same network, it should be set to Yes. If using a Public IP address, set this parameter to No.
3. **NAT Traversal** (under the Profile web page)
Set this to Yes when gateway is behind firewall on a private network.

DTMF Methods

DTMF Settings are in [ProfileX page](#).

- DTMF in-audio
- DTMF via RTP (RFC2833)
- DTMF via SIP INFO

Set priority of DTMF methods according to your preference. This setting should be based on your server DTMF setting.

Preferred VOCODER (Codec)

The DP715 supports a broad range of voice codecs. Under Profile web pages, choose your preferred order of different codecs:

- G711a/u
- G729AB
- G723.1
- iLBC
- G726-32 AAL2
- G722

Table 7: Basic Settings

End User Password	Password to access the Web Configuration Menu. This field is case sensitive with a maximum length of 25 characters.
Web Port	By default, HTTP uses port 80. This field is for customizable web port.
Telnet Server	Default is set to YES.
IP Address	There are two modes to operate the DP715: DHCP mode: all the field values for the Static IP mode are not used (even though they are still saved in the Flash memory.) The DP715 acquires its IP address from the first DHCP server it discovers from the LAN it is connected. <i>Using the PPPoE feature:</i> set the PPPoE account settings. The DP715 will establish a PPPoE session if any of the PPPoE fields is set. Static IP mode: configure the IP address, Subnet Mask, Default Router IP address, DNS Server 1 (primary), DNS Server 2 (secondary) fields. These fields are set to zero by default.
DHCP hostname	Default is blank . This option specifies the name of the client. This field is optional but may be required by some Internet Service Providers.

DHCP domain	Default is blank . This option specifies the domain name that client should use when resolving hostnames via the Domain Name System.
DHCP vendor class ID	Default is HT7XX . Used by clients and servers to exchange vendor-specific information..
PPPoE account ID	PPPoE username. Necessary if ISP requires you to use a PPPoE (Point to Point Protocol over Ethernet) connection.
PPPoE password	PPPoE account password.
PPPoE Service Name	Default is blank . This field is optional. If your ISP uses a service name for the PPPoE connection, enter the service name here.
Preferred DNS server	The preferred DNS Server to be used
Time Zone	Controls how the date/time is displayed according to the specified time zone.
Self-Defined Time Zone	<p>The syntax is std offset dst [offset],start[/time],end[/time] Default is set to : MTZ+6MDT+5,M3.2.0,M11.1.0</p> <p>MTZ+6MDT+5, Time zone with 6 hours offset with 1 hour ahead which is the US central time. It is positive (+) if the local time zone is west of the Prime Meridian and negative (-) if it is east. Prime Meridian (a.k.a: International or Greenwich Meridian)</p> <p>M3.2.0,M11.1.0 The 1st number indicates Month: 1,2,3,..,12 (for Jan, Feb, .., Dec) The 2nd number indicates the nth iteration of the weekday: (1st Sunday, 3rd Tuesday etc) The 3rd number indicates Weekday: 0,1, 2, ..,6(for Sun, Mon, Tue, .., Sat) Therefore, this example is the DST which starts from the second Sunday of March to the 1st Sunday of November.</p>
Allow DHCP server to set Time Zone	Default No. Let the DHCP server handle the Time Zone
Language	Languages supported with voice prompt and web interface, except Spanish that it is only in IVR.
Reset Type	<p>Gives the user the option to set to default all VoIP related configuration (mainly everything located on Profile page), all ISP (Internet Service Provider) configuration which may affect the IP address, or both at the same time.</p> <p>Note: After you choose the reset type, you will have to click the reset button for it to take effect.</p>

In addition to the Basic Settings configuration page, end users also have access to the Device Status page.

Table 8: Status Page

MAC Address	The device ID, in HEX format. This is very important ID for ISP troubleshooting. The Mac address will appear in this place. The MAC address will be used for provisioning and can be found on the label coming with original box and on the label located on the bottom panel of the device.
RFPI Address	
IP Address	This field shows the IP address of the DP715.
Product Model	This field contains the product model info.
Hardware Version	This field shows the hardware revision of the unit and the part number.
Software Version	Program: This is the main software release. <i>This number is always used for firmware upgrade.</i> Current release is 1.0.0.18 Boot and Loader are seldom changed. Bootloader: current version is 1.0.0.6. Core: current version 1.0.0.18 Base: current version is 1.0.0.18
System Up Time	Shows system up time since the last reboot.
PPPoE Link Up	Indicates whether the PPPoE connection is up if the DP715 is connected to DSL modem.
NAT	This field indicates the type of NAT connection used by the DP715.
SIP Account Registration Status:	
Handset Status	

ADVANCED USER CONFIGURATION

Log in to the advanced user configuration page the same way as for the basic configuration page. The password is case sensitive and the factory default password for Advanced User is “*admin*”.

Advanced User configuration includes the end user configuration and the advanced configurations including: a) SIP configuration, b) Codec selection, c) NAT Traversal Setting and d) other miscellaneous configuration. DP715 has two (2) profiles for the four (5) Handset DP710.

Table 9: Advanced Settings

Admin Password	This contains the password to access the Advanced Web Configuration page. This field is case sensitive. Only the administrator can configure the “Advanced Settings” page. Password field is purposely left blank for security reasons after clicking update and saved. The maximum password length is 25 characters.
Layer 3 QoS	This field defines the layer 3 QoS parameter which can be the value used for IP Precedence or Diff-Serv or MPLS. Default value is 48 .
Layer 2 QoS	Value used for layer 2 VLAN tag. Default setting is blank .
STUN Server	IP address or Domain name of the STUN server.
Keep-alive interval	This parameter specifies how often the DP715 sends a blank UDP packet to the SIP server in order to keep the “hole” on the NAT open. Default is 20 seconds. Minimum value is 20 seconds.
Use STUN to detect network connectivity	Use STUN keep-alive to detect WAN side network problems. If keep-alive request does not yield any response for configured number of times, the device will restart the TCP/IP stack. If the STUN server does not respond when the device boots up, the feature is disabled. Default setting is No .
Firmware Upgrade and Provisioning	Enables DP715 to download firmware or configuration file through either the TFTP, HTTP or HTTPS server.
Via TFTP Server	This is the IP address of the configured TFTP server. If selected and it is non-zero or not blank, the DP715 retrieves the new configuration file or new code image from the specified TFTP server at boot time. After 5 attempts, the system will timeout and will start the boot process using the existing code image in the Flash memory. If a TFTP server is configured and a new code image is retrieved, the new downloaded image is saved into the Flash memory. <u>Note:</u> Please do NOT interrupt the TFTP upgrade process (especially the power supply) as this will damage the device. Depending on the local network, this process can take up to 15 or 20 minutes.
Via HTTP / HTTPS Server	The URL for the HTTP/HTTPS server used for firmware upgrade and configuration via HTTP. <i>For example, http://provisioning.mycompany.com:6688/Grandstream/1.0.0.67:6688</i> is the specific TCP port where the HTTP or HTTPS server is listening; it can be omitted if using default port 80. <u>Note:</u> If Auto Upgrade is set to No, DP715 will only do HTTP/HTTPS download once at boot up.
Firmware Server Path	IP address or domain name of firmware server.
Config Server Path	IP address or domain name of configuration server.
XML Config File Password	The password used for encrypting the XML configuration file using OpenSSL. This is required for the phone to decrypt the encrypted XML configuration file.
HTTP/HTTPS User Name	The user name needed to authenticate with the HTTP/HTTPS server.
HTTP/HTTPS Password	The password needed to authenticate with the HTTP/HTTPS server.
Firmware File Prefix	Default is blank . If configured, DP715 will request firmware file with the prefix. This setting is useful for ITSPs. End user should keep it blank.

Firmware File Postfix	Default is blank . End user should keep it blank.
Config File Prefix	Default is blank . End user should keep it blank.
Config File Postfix	Default is blank . End user should keep it blank.
Allow DHCP Option 66 to override server	If set to "Yes", configuration and upgrade server information can be obtained using DHCP option 66 from DHCP server located in customer's environment. Default setting is Yes .
Automatic Upgrade	Choose "Yes" to enable automatic upgrade and provisioning. If select "Check every minutes" input the amount of minutes you want it to check for update. If select "Yes, daily at hour" make sure to input the hour of the day you want it to check for update, e.g. for 11 pm type 23. If select "Yes, weekly on day" make sure you input the day of the week (in format 0-6, 0 is Sunday) you want it to check for update. When set to No, DP715 will only do the following option you select; "Always check for New Firmware at Boot up" will check for new firmware every time the device reboots. "Check New Firmware only when F/W pre/suffix changes" will check for updates only when the pre/suffix has been changed.
Authenticate Conf File	If set to Yes, config file is authenticated before acceptance. This protects the configuration from an unauthorized change.
Firmware Key	Used for firmware encryption. Should be 32 digit in hexadecimal representation. End user should keep it blank.
SSL Certificate	The user specify SSL certificate used for SIP over TLS in X.509 format.
SSL Private Key	The user specify SSL private key used for SIP over TLS in X.509 format.
SSL Private Key Password	User specify password to protect the private key above.
ACS URL	User specify the Auto Configuration Server's URL (TR-069 protocol)
ACS Username	User specify the ACS Username
ACS Password	User specify the ACS password
Periodic Inform Enable	Default is No . If set to YES, device will send inform packets to the ACS
Periodic Inform Interval	Frequency that the inform packets will be sent out to the ACS
Connection Request Username	Set a user name for the ACS to connect to this device
Connection Request Password	Set a password for the ACS to connect to this device
Call Progress Tones	Using these settings, users can configure tone frequencies and cadence according to their preference. By default they are set to North American frequencies. Configure these settings with known values to avoid uncomfortable high pitch sounds. ON is the period of ringing ("On time" in 'ms') while OFF is the period of silence. In order to set a continuous tone, OFF should be zero. Otherwise it will ring ON ms and a pause of OFF ms and then repeat the pattern. <u>Example configuration for N.A. Dialtone:</u> f1=350@-13,f2=440@-13,c=0/0; Syntax: f1=freq@vol, f2=freq@vol, c=on1/off1-on2/off2-on3/off3; [...] (Note: freq: 0 - 4000Hz; vol: -30 - 0dBm)

Lock Keypad Update	Default is No . If set to "Yes", the configuration update via keypad is disabled.
Disable Voice Prompt	Default is No . Disables the voice prompt configuration.
Disable Direct IP Call	Default is No . Disables the Direct IP Call function.
Failover to FXO Gateway	Default is Disable . If Enabled, the unit will start routing the calls to the FXO Gateway configured via Direct IP Call When it loses registration from your SIP Server. The use of this option presumes a configured GXW410x or another FXO gateway with an active PSTN line connection.
FXO Gateway	IP or Domain Name of the FXO Gateway that will be used as Failover.
NTP server	URI or IP address of the NTP (Network Time Protocol) server. This parameter synchronizes the date and time.
Allow DHCP option 42 to override NTP serve	Default NO . Enables the DHCP server to handle the NTP Server via Option 42
Syslog Server	The IP address or URL of System log server. This feature is especially useful for the ITSP (Internet Telephone Service Provider)
Syslog Level	<p>Select the DP715 to report the log level. Default is NONE. The level is one of DEBUG, INFO, WARNING or ERROR. Syslog messages are sent based on the following events:</p> <ol style="list-style-type: none"> 1. product model/version on boot up (INFO level) 2. NAT related info (INFO level) 3. sent or received SIP message (DEBUG level) 4. SIP message summary (INFO level) 5. inbound and outbound calls (INFO level) 6. registration status change (INFO level) 7. negotiated codec (INFO level) 8. Ethernet link up (INFO level) 9. SLIC chip exception (WARNING and ERROR levels) 10. memory exception (ERROR level) <p>The Syslog uses USER facility. In addition to standard Syslog payload, it contains the following components:</p> <p>GS_LOG: [device MAC address][error code] error message</p> <p><u>Example</u>: May 19 02:40:38 192.168.1.14 GS_LOG: [00:0b:82:00:a1:be][000] Ethernet link is up</p>
Send SIP Log	Default is No . If Enabled, the DP715 will send a replicate of the SIP packets on the syslog.
Primary RADIUS Server	<p>Set the IP or FQDN of the Primary RADIUS Server.</p> <p>Remote Authentication Dial In User Service (RADIUS). DP715 supports RADIUS for authentication, authorization and billing purposes. Primary and secondary RADIUS server configurations are available to provide redundancy to this feature. In case Primary Radius server becomes unusable, RADIUS requests will be automatically sent to the secondary server. When at least one RADIUS server was configured, the device will allow users to make phone calls only after authorization from RADIUS server has been received. CDR (Call Detail Record) is also sent to the RADIUS server for billing purposes. RADIUS server can send requests to terminate calls when run out of pre-paid credit.</p>
Primary RADIUS Auth Port	Default is 1812 . Specifies the port to be used for the Primary RADIUS Authentication.

Primary RADIUS Acct Port	Default is 1813 . Specifies the port to be used for the Primary RADIUS Account.
Primary RADIUS Server Secret	Specifies the secret string to be used to authenticate the RADIUS connection to the Primary Server. It should match RADIUS configuration.
RADIUS Timeout	Default is 2 .
RADIUS Retry	Default is 3 .
Download Device Configuration	Allows user to download and save a text file containing all the P values of each setting as configured at that point on the unit. (Note: For Security Reasons, all Passwords won't be Downloaded)
Upload Firmware	Allows the user to upgrade the firmware with a single firmware file by browsing and loading the file from your computer (local directory).

Table 10: Profile Settings

Profile Active	When set to Yes the Profile is activated.
Primary SIP Server	SIP Server's IP address or Domain name provided by VoIP service provider.
Failover SIP Server	Failover SIP Server's IP address or Domain name in case primary server does not respond.
Prefer Primary SIP Server	Default is No . If set to yes, it will register to Primary Server if registration with Failover server expires
Outbound Proxy	IP address or Domain name of Outbound Proxy, or Media Gateway, or Session Border Controller. Used by DP715 for firewall or NAT penetration in different network environments. If symmetric NAT is detected, STUN will not work and ONLY outbound proxy can correct the problem.
SIP transport	User can select UDP or TCP or TLS. Default is UDP .
NAT Traversal (STUN)	This parameter defines whether or not the DP715 NAT traversal mechanism is activated. If activated (by choosing "Yes") and a STUN server is also specified, then the DP715 performs according to the STUN client specification. Using this mode, the embedded STUN client will detect if and what type of firewall/NAT. If the detected NAT is a Full Cone, Restricted Cone, or a Port-Restricted Cone, the DP715 will use its mapped public IP address and port in all of its SIP and SDP messages. If the NAT Traversal field is set to "Yes" <i>with no specified STUN server</i> , the DP715 will periodically (every 20 seconds or so) send a blank UDP packet (with no payload data) to the SIP server to keep the "hole" on the NAT open.
DNS Mode	One from the 3 modes are available for "DNS Mode" configuration: -A Record (for resolving IP Address of target according to domain name) -SRV (DNS SRV resource records indicates how to find services for various protocols) -NAPTR/SRV (Naming Authority Pointer according to RFC 2915) One mode can be chosen for the client to look up server. The default value is "A Record"
Tel URI	The default setting is " Disabled ". If the phone has an assigned PSTN Number, this field should be set to "User=Phone" then a "User=Phone" parameter will be attached to the "From header" in the SIP request to indicate the E.164 number. If server supports TEL URI format, then this option needs to be selected.

SIP Registration	Controls whether the DP715 needs to send REGISTER messages to the proxy server. The default setting is Yes .
Unregister on Reboot	Default is No . If set to Yes, the SIP user's registration information will be cleared on reboot.
Outgoing Call without Registration	Default is No . If set to "Yes," user can place outgoing calls even when not registered (if allowed by Internet Telephone Service Provider) but is unable to receive incoming calls.
Register Expiration	This parameter allows the user to specify the time frequency (in minutes) the DP715 refreshes its registration with the specified registrar. The default interval is 60 minutes (or 1 hour). The maximum interval is 65535 minutes (about 45 days).
Registration Retry Wait Time	Retry registration if the process failed. Default is 20 seconds.
Local SIP port	Defines the local SIP port the DP715 will listen and transmit.
Local RTP port	Defines the local RTP-RTCP port pair the DP715 will listen and transmit. It is the base RTP port for channel 0. When configured, channel 0 uses this port _value for RTP and the port_value+1 for its RTCP
Use Random Port	Default is No . This parameter forces the random generation of both the local SIP and RTP ports when set to Yes. This is usually necessary when multiple DP715 are behind the same NAT.
Refer to Use Target Contact	Default is No . If set to YES, then for Attended Transfer, the "Refer-To" header uses the transferred target's Contact header information.
Transfer on Conference Hang up	Default is No . In which case if the conference originator hangs up the conference will be terminated. When option YES is chosen, originator will transfer other parties to each other so that B and C can choose to either continue the conversation or hang up.
Enable Ring-Transfer	Default is No , this will create a Semi-Attendant Transfer. When set to Yes, device can transfer the call upon receiving ring back tone or SIP message 180.
Disable Bellcore Style 3-Way Conference	Default is No . you can make a Conference by pressing 'Flash' key. If set to Yes , you need to dial *23 + second callee number.
Remove OBP from Route Header	Default is No . When option YES is chosen, the Out Bound Proxy will be removed from Route header.
Support SIP Instance ID	Default is Yes . If set to Yes, the contact header in REGISTER request will contain SIP Instance ID as defined in IETF SIP Outbound draft.
Validate incoming SIP message	Default is No . If set to yes all incoming SIP messages will be strictly validated according to RFC rules. If message will not pass validation process, call will be rejected.
Check SIP User ID for incoming INVITE	Default is No . Check the incoming SIP User ID in Request URI. If they don't match, the call will be rejected. If this option is enabled, the device will not be able to make direct IP calls.
Allow Incoming SIP Messages from SIP Proxy Only	Default is No . Check the incoming SIP messages. If they don't come from the SIP proxy, they will be rejected. If this option is enabled, the device will not be able to make direct IP calls.
SIP T1 Timeout	T1 is an estimate of the round-trip time between the client and server transactions. If the network latency is high, select larger value for more reliable usage. Default is 0.5 Sec .
SIP T2 Interval	Maximum retransmission interval for non-INVITE requests and INVITE responses. Default is 4 Sec .
DTMF Payload Type	Sets the payload type for DTMF using RFC2833. Default is 101 .
Preferred DTMF method	The DP715 supports up to 3 different DTMF methods including in-audio, via RTP (RFC2833) and via Sip Info using SIP INFO messages. The user can configure DTMF method in a priority list.
Disable DTMF Negotiation	Default is No . If set to yes, use above DTMF order without negotiation
Send Flash Event	Default is No . If set to yes, flash will be sent as DTMF event.
Enable Call Features	Default is Yes . (If Yes, call features using star codes will be supported locally)

Proxy-Require	SIP Extension to notify SIP server that the unit is behind the NAT/Firewall.
Use NAT IP	NAT IP address used in SIP/SDP message. Default is blank.
Ring Timeout	Default value is 60 Sec . Incoming call will stop ringing when not picked up given a specific period of time.
Hunting Group Ring Timeout	Default value is 20 Sec . If call is not answered within this designated time period, the call will be forwarded to the next member of a Hunt Group.
Hunting Group Type	Linear, Circular, parallel and Shared line. Default is Circular . Linear style will sort the call to the lowest-numbered available line; this is also called "serial hunting". Circular style will distribute the calls "round-robin". If a call is assigned to line 1, the next call goes to 2 and the next to 3. The succession throughout each of the lines continues even if one of the previous lines becomes available. When the end of the hunt group is reached, the hunting starts over at the first line. Lines are skipped if they are still busy on a previous call.
Delayed Call Forward Wait Time	Default value is 20 seconds . In case this feature activated using * codes (*92 code), the call will be forwarded after this preconfigured amount of time.
No Key Entry Timeout	Default is 4 seconds . Dialing process is completed and outgoing call is initiated if no key entry occurs during this preconfigured interval.
Early Dial	<p>Default is No. Use only if proxy supports 484 response. This parameter controls whether the phone will send an early INVITE each time a key is pressed when a user dials a number. If set to "Yes", an INVITE is sent using the dial-number collected thus far; Otherwise, no INVITE is sent until the "(Re-)Dial" button is pressed or after about 5 seconds have elapsed if the user forgets to press the "Re-Dial" button.</p> <p>The "Yes" option should be used ONLY if there is a SIP proxy configured and the proxy server supports 484 Incomplete Address response. Otherwise, the call will likely be rejected by the proxy (with a 404 Not Found error).</p> <p><i>This feature does NOT work with and should NOT be enabled for direct IP-to-IP calling.</i></p>
Dial Plan Prefix	Sets the prefix added to each dialed number.
Use # as Dial Key	Default is Yes . It allows users to configure the "#" key as the "Send" (or "Dial") key. If set to "Yes", "#" will send the number. In this case, this key is essentially equivalent to the "Dial" key. If set to "No", this "#" key can be included as part of number.
Dial Plan	<p>Dial Plan Rules:</p> <ol style="list-style-type: none"> Accepted Digits: 1,2,3,4,5,6,7,8,9,0 , * , #, A,a,B,b,C,c,D,d Grammar: x - any digit from 0-9; <ol style="list-style-type: none"> xx+ - at least 2 digit numbers xx. - only 2 digit numbers ^ - exclude [3-5] - any digit of 3, 4, or 5 [147] - any digit of 1, 4, or 7 <2=011> - replace digit 2 with 011 when dialing - the OR operand <ul style="list-style-type: none"> Example 1: {[369]11 1617xxxxxx} <p>Allow 311, 611, and 911 or any 10 digit numbers with leading digits 1617</p> <ul style="list-style-type: none"> Example 2: {^1900x+ <=1617>xxxxxx} <p>Block any number of leading digits 1900 or add prefix 1617 for any dialed 7 digit numbers</p> <ul style="list-style-type: none"> Example 3: {1xxx[2-9]xxxxxx <2=011>x+} <p>Allows any number with leading digit 1 followed by a 3 digit number, followed by any number between 2 and 9, followed by any 7 digit number OR Allows any length of numbers with leading digit 2, replacing the 2 with 011 when dialed.</p> <ol style="list-style-type: none"> Default: Outgoing – {x+} <p>Allow any length of numbers.</p>

	<p>Example of a simple dial plan used in a Home/Office in the US: <code>{ ^1900x. <=1617>[2-9]xxxxxx 1[2-9]xx[2-9]xxxxxx 011[2-9]x. [3469]11 }</code> Explanation of example rule (reading from left to right):</p> <ul style="list-style-type: none"> • ^1900x. - prevents dialing any number started with 1900 • <=1617>[2-9]xxxxxx - allows dialing to local area code (617) numbers by dialing 7 numbers and 1617 area code will be added automatically • 1[2-9]xx[2-9]xxxxxx - allows dialing to any US/Canada Number with 11 digits length • 011[2-9]x. - allows international calls starting with 011 • [3469]11 - allow dialing special and emergency numbers 311, 411, 611 and 911 <p>Note: In some cases where the user wishes to dial strings such as *123 to activate voice mail or other applications provided by their service provider, the * should be predefined inside the dial plan feature. An example dial plan will be: { *x+ } which allows the user to dial * followed by any length of numbers.</p>
SUBSCRIBE for MWI	Default is “No”. When set to “Yes” a SUBSCRIBE for Message Waiting Indication will be sent periodically.
Send Anonymous:	If this parameter is set to “Yes”, the “From” header in outgoing INVITE message will be set to anonymous, essentially blocking the Caller ID from displaying.
Disable Call Waiting	Default is No . If set to YES Call Waiting indication information will not be provided to Handset.
Disable Call-Waiting Caller ID	Default is No . If set to YES Call Waiting caller ID will not be provided to the handset.
Reminder Ring for On-Hold Call	Default is Disable . Play the reminder ring when this is set to Enable.
Anonymous Call Rejection	Default is “No”. If set to “Yes”, anonymous call will be rejected.
Session Expiration	<p>The SIP Session Timer extension enables SIP sessions to be periodically “refreshed” via a SIP request (UPDATE, or re-INVITE. Once the session interval expires, if there is no refresh via a UPDATE or re-INVITE message, the session is terminated.</p> <p>Session Expiration is the time (in seconds) at which the session is considered timed out, provided no successful session refresh transaction occurs beforehand. The default value is 180 seconds.</p>
Min-SE	Defines the minimum session expiration (in seconds). Default is 90 seconds.
Caller Request Timer	If set to “Yes”, the phone will use session timer when it makes outbound calls if remote party supports session timer.
Callee Request Timer	If selecting “Yes”, the phone will use session timer when it receives inbound calls with session timer request.
Force Timer	If set to “Yes”, the phone will use session timer even if the remote party does not support this feature. If set to “No”, the session timer is enabled only when the remote party supports this feature. To turn off Session Timer, select “No” for Caller Request Timer, Callee Request Timer, and Force Timer.
UAC Specify Refresher	As a Caller, select UAC to use the phone as the refresher, or UAS to use the Callee or proxy server as the refresher.
UAS Specify Refresher	As a Callee, select UAC to use caller or proxy server as the refresher, or UAS to use the phone as the refresher.

Force INVITE	Session Timer can be refreshed using INVITE method or UPDATE method. Select "Yes" to use INVITE method to refresh the session timer.
Enable 100rel	PRACK (Provisional Acknowledgment) method enables reliability to SIP provisional responses (1xx series).
Preferred Vocoder	The DP715 supports up to 6 different Vocoder types including G.711 A-/U-law, G.726-32 , G.723, G.729A/B and iLBC. The user can configure Vocoders in a preference list that will be included with the same preference order in SDP message. The first Vocoder is entered by choosing the appropriate option in "Choice 1". The last Vocoder is entered by choosing the appropriate option in "Choice 6".
VAD	Default is No . VAD allows detecting the absence of audio and conserves bandwidth by preventing the transmission of "silent packets" over the network.
Jitter Buffer Type	Select either Fixed or Adaptive based on network conditions.
Jitter Buffer Length	Select Low, Medium, or High based on network conditions.
SRTP Mode	Secure RTP protocol used for media transmission over VoIP. Disabled by default. Other modes are: enabled but not forced & enabled and forced.
G723 Rate	This defines the encoding rate for G723 vocoder. Default setting is 6.3kbps.
Use First Matching Vocoder in 200OK SDP	Default is No . If set to "Yes", device will include only the first match vocoder in its 200OK response, otherwise it will include all match vocoders in same order received in INVITE.
iLBC Frame Size	This sets the iLBC size in 20ms or 30ms
Voice Frames per Packet	This field contains the number of voice frames to be transmitted in a single packet. When setting this value, the user should be aware of the requested packet time (used in SDP message) as a result of configuring this parameter. This parameter is associated with the first vocoder in the above vocoder Preference List or the actual used payload type negotiated between the 2 conversation parties at run time. Default is 2, up to 10/20/32/64 for G711/G726/G723/other codecs respectively)
Symmetric RTP	Default is No . When set to "Yes" the device will change the destination to send RTP packets to the source IP address and port of the inbound RTP packet last received by the device.

Table 11: DP715 Handsets Settings

Ring All Handsets Button	This button will allow you to ring all the handset registered with the base station
Clear all handset registrations Button	This button is used to de-register all the handset previously registered with the base station
Enable Subscription Mode Button	This button will allow you to set the DP715 under subscription mode in order to register a new handset. Note: Subscription mode is automatically exited after 120 seconds.
Ring Handset	Allow you to locate the handset corresponding to the specific account.
Profile ID	Select the corresponding Profile ID between Profile 1 and Profile 2.
Hunting Group	This feature enables the DP715 to register all existing Handsets with the same phone number. Each incoming call will be routed to first available port in Linear or Circular mode. User may configure all ports as members of the same Hunting Group or it may configure different port combinations for more than one Hunting Group. For example: Handset 1, 3 and 5 are members of the same Hunting Group, the rest of the Handsets may have separate numbers and may be reached independently. Any Handset, member of a Hunting Group that is not registered with a SIP account, will be able to place outbound calls using the SIP credentials of the primary Hunting Group Handset.

	<p>For example: Port 1, 2, and 3 are members of the same Hunting Group. Handset 1 is registered with a SIP account. Handset 2, and 3 are not registered. Handset 2 and 3 will be able to place outbound calls using the SIP account of Handset 1. Select appropriate value for Hunting Group feature. The original SIP account should be set to Active while the group members should be set to the port number of the Active Handset.</p> <p>Example configuration of a Hunting group: Handset #1: SIP UserID and Authenticate ID entered, Hunting group set to "Active" Handset #2: SIP UserID and Authenticate ID left blank, Hunting Group set to "1" Handset #3: SIP UserID and Authenticate ID left blank, Hunting Group set to "1" Handset #4: SIP UserID and Authenticate ID entered, Hunting group set to "None" Hunting Group 1 contains Handset 1, 2, 3. Handset 4 is registered but it is not added to the Hunting Group 1.</p>
SIP User ID	User account information, provided by VoIP service provider (ITSP). Usually in the form of digit similar to phone number or actually a phone number.
Authenticate ID	SIP service subscriber's Authenticate ID used for authentication. Can be identical to or different from SIP User ID.
Authenticate Password	SIP service subscriber's account password.
Name	SIP service subscriber's name for Caller ID display.

SAVING THE CONFIGURATION CHANGES

Click the "Update" button in the Configuration page to save the changes to the DP715 configuration. The following screen confirms that the changes are saved. Reboot or power cycle the DP715 to make the changes take effect.

REBOOTING THE DP715 BASE STATION FROM REMOTE

Press the "Reboot" button at the bottom of the configuration menu to reboot the DP715 Base Station remotely. The web browser will then display a message window to confirm that reboot is underway. Wait 30 seconds to log in again.

CONFIGURATION THROUGH A CENTRAL SERVER

Grandstream DP715 Base Station can be automatically configured from a central provisioning system.

When the base station boots up, it will send TFTP or HTTP/HTTPS request to download configuration file, "cfg000b82xxxxxx" or "cfg00082xxxxxx.xml", where "000b82xxxxxx" is the MAC address of the DP715. It will first request "cfg000b82xxxxxx" then "cfg000b82xxxxxx.xml"

The configuration file can be downloaded via TFTP or HTTP/HTTPS from the central server. A service provider or an enterprise with large deployment of DP715 can easily manage the configuration and service provisioning of individual devices remotely from a central server.

Grandstream has a provisioning system called GAPS (Grandstream Automated Provisioning System) that is used to support automated configuration of Grandstream devices. GAPS uses enhanced (NAT friendly) TFTP or HTTP (thus no NAT issues) and other communication protocols to communicate with each individual Grandstream device for firmware upgrade, remote reboot, etc.

Grandstream provides GAPS service to VoIP service providers. Use GAPS for either simple redirection or with certain special provisioning settings. At boot-up, Grandstream devices by default point to Grandstream provisioning server GAPS, based on the unique MAC address of each device, GAPS provision the devices

with redirection settings so that they will be redirected to customer's TFTP or HTTP/HTTPS server for further provisioning. Grandstream also provide GAPSLITE software package which contains our NAT friendly TFTP server and a configuration tool to facilitate the task of generating device configuration files.

The GAPSLITE configuration tool is now free to end users. The tool and configuration template are available for download from <http://www.grandstream.com/support/tools> .

SOFTWARE UPGRADE

Software upgrade can be done via either TFTP or HTTP or HTTPS. The corresponding configuration settings are in the ADVANCED SETTINGS configuration page.

FIRMWARE UPGRADE THROUGH TFTP/HTTP/HTTPS

To upgrade via TFTP or HTTP/HTTPS, the "Firmware Upgrade and Provisioning upgrade via" field needs to be set to TFTP HTTP or HTTPS, respectively. "Firmware Server Path" needs to be set to a valid URL of a TFTP or HTTP server, server name can be in either FQDN or IP address format. Here are examples of some valid URL.

e.g. `firmware.mycompany.com:6688/Grandstream/1.0.0.18`

e.g. `72.172.83.110`

NOTES:

- Firmware upgrade server in IP address format can be configured via IVR. Please refer to the CONFIGURATION GUIDE section for instructions. If the server is in FQDN format, it must be set via the web configuration interface.
- Grandstream recommends end-user use the Grandstream HTTP server. Its address can be found at <http://www.grandstream.com/support/firmware> . Currently the HTTP firmware server IP address is 72.172.83.110. For large companies, we recommend to maintain their own TFTP/ HTTP/HTTPS server for upgrade and provisioning procedures.
- Once a "Firmware Server Path" is set, user needs to update the settings and reboot the device. If the configured firmware server is found and a new code image is available, the DP715 will attempt to retrieve the new image files by downloading them into the DP715's SRAM. During this stage, the DP715's LEDs will blink until the checking/downloading process is completed. Upon verification of checksum, the new code image will then be saved into the Flash. If TFTP/HTTP/HTTPS fails for any reason (e.g. TFTP/HTTP/HTTPS server is not responding, there are no code image files available for upgrade, or checksum test fails, etc), the DP715 will stop the TFTP/HTTP/HTTPS process and simply boot using the existing code image in the flash.
- Firmware upgrade may take as long as 15 to 30 minutes over Internet, or just 5 minutes if it is performed on a LAN. It is recommended to conduct firmware upgrade in a controlled LAN environment if possible. For users who do not have a local firmware upgrade server, Grandstream provides a NAT-friendly TFTP server on the public Internet for firmware upgrade.
- Grandstream's latest firmware is available at <http://www.grandstream.com/support/firmware> .
Oversea users are strongly recommended to download the binary files and upgrade firmware locally in a controlled LAN environment.

Note: Alternatively, the user can upload the firmware single file from his/her computer using a local directory. For more instructions see below. Also the user can download a free TFTP or HTTP server and conduct local firmware upgrade. A free windows version TFTP server is available for download from <http://support.solarwinds.net/updates/New-customerFree.cfm>. Our latest official release can be downloaded from <http://www.grandstream.com/support/firmware>.

INSTRUCTIONS FOR UPLOAD FROM LOCAL DIRECTORY:

- 1- Download the firmware file from Grandstream web site
- 2- Unzip it and copy the file in to a folder in your PC
- 3- From the DP715 web interface (Advanced Settings page) you can browse your hard drive and select the folder where you previously saved the file.
- 4- Click "Upload Firmware" and wait few minutes until the new program is loaded.

Note: Always check the status page to see that the program version has changed.

INSTRUCTIONS FOR LOCAL FIRMWARE UPGRADE USING TFTP SERVER:

1. Unzip the file and put all of them under the root directory of the TFTP server.
2. Put the PC running the TFTP server and the DP715 device in the same LAN segment.
3. Please go to File -> Configure -> Security to change the TFTP server's default setting from "Receive Only" to "Transmit Only" for the firmware upgrade.
4. Start the TFTP server, in the phone's web configuration page
5. Configure the Firmware Server Path with the IP address of the PC
6. Update the change and reboot the unit

End users can also choose to download the free HTTP server from <http://httpd.apache.org/> or use Microsoft IIS web server.

CONFIGURATION FILE DOWNLOAD

Grandstream SIP Device can be configured via Web Interface as well as via Configuration File through TFTP or HTTP/HTTPS. "Config Server Path" is the TFTP or HTTP/HTTPS server path for configuration file. It needs to be set to a valid URL, either in FQDN or IP address format. The "Config Server Path" can be same or different from the "Firmware Server Path".

A configuration parameter is associated with each particular field in the web configuration page. A parameter consists of a Capital letter P and 1 to 3 (Could be extended to 4 in the future) digit numeric numbers. i.e., P2 is associated with "Admin Password" in the ADVANCED SETTINGS page. For a detailed parameter list, please refer to the corresponding firmware release configuration template.

When Grandstream Device boots up or reboots, it will issue request for configuration file named "cfgxxxxxxxxxx", where "xxxxxxxxxx" is the MAC address of the device, i.e., "cfg000b820102ab". The configuration file name should be in lower cases.

Firmware and Configuration File Prefix and Postfix

Firmware Prefix and Postfix allows device to download the firmware name with the matching Prefix and Postfix. This makes it the possible to store ALL of the firmware with different version in one single directory. Similarly, Config File Prefix and Postfix allows device to download the configuration file with the matching Prefix and Postfix. Thus multiple configuration files for the same device can be stored in one directory.

In addition, when the field “Check New Firmware only when F/W pre/suffix changes” is set to “Yes”, the device will only issue firmware upgrade request if there are changes in the firmware Prefix or Postfix.

MANAGING FIRMWARE AND CONFIGURATION FILE DOWNLOAD

When “Automatic Upgrade” is set “**Yes, every**” the auto check will be done in the minute specified in this field. If set to “**daily at hour (0-23)**”, Service Provider can use P193 (Auto Check Interval) to have the devices do a daily check at the hour set in this field with either Firmware Server or Config Server. If set to “**weekly on day (0-6)**” the auto check will be done in the day specified in this field. This allows the device periodically check if there are any new changes need to be taken on a scheduled time. By defining different intervals in P193 for different devices, Server Provider can spread the Firmware or Configuration File download in minutes to reduce the Firmware or Provisioning Server load at any given time.

Automatic Upgrade:

- No Yes, every minutes(60-5256000).
- Yes, daily at hour (0-23). Yes, weekly on day (0-6).

RESTORE FACTORY DEFAULT SETTING

WARNING! Restoring the Factory Default Setting will DELETE all configuration information of the phone. Please BACKUP or PRINT out all the settings before you approach to following steps. Grandstream will not take any responsibility if you lose all the parameters of setting and cannot connect to your VoIP service provider.

BASE STATION

There are Three (3) methods for resetting the DECT base station:

1. Reset Button

Reset default factory settings following these four (4) steps:

1. Unplug the Ethernet cable.
2. Locate a needle-sized hole on the back panel of the gateway unit next to the power connection.
3. Insert a pin in this hole, and press for about 7 seconds.
4. Take out the pin. All unit settings are restored to factory settings.

2. IVR Command

Reset default factory settings using the IVR Prompt (Table 5):

1. Dial “****” for voice prompt.
2. Enter “99” and wait for “reset” voice prompt.
3. Enter the encoded MAC address (Look below on how to encode MAC address).
4. Wait 15 seconds and device will automatically reboot and restore factory settings.

Encode the MAC Address

1. Locate the MAC address of the device. It is the 12 digit HEX number on the bottom of the unit.
2. Key in the MAC address. Use the following mapping:
 - 0-9: 0-9
 - A: 22 (press the “2” key twice, “A” will show on the LCD)
 - B: 222
 - C: 2222
 - D: 33 (press the “3” key twice, “D” will show on the LCD)
 - E: 333
 - F: 3333

For example: if the MAC address is 000**b**8200**e**395, it should be keyed in as “000**222**8200**333**395”.

3. Reset from web interface (Reset Type)

1. From the Advanced Settings Page user can select three types:
 - **Full Reset:** This will make a full reset
 - **ISP Data:** This will reset only the basic settings, like IP mode, PPPoE and Web port
 - **VOIP Data:** This will reset only the data related with a service provider like SIP server, sip user ID, provisioning and others.

NOTE:

1. **Factory Reset will be disabled if the “Lock keypad update” is set to “Yes”.**
2. **If the DP715 was previously locked by your local service provider, pressing the RESET button will only restart the unit. The device will not return to factory default settings.**

HANDSET

Press and hold the 'R' key until "Handset Reset?" appears. Select the check mark option with the soft key to reset the handset.

FCC Caution:

Any Changes or modifications not expressly approved by the party responsible for compliance could void the user's authority to operate the equipment.

This device complies with part 15 of the FCC Rules. Operation is subject to the following two conditions:

(1) This device may not cause harmful interference, and (2) this device must accept any interference received, including interference that may cause undesired operation.

Note: This equipment has been tested and found to comply with the limits for a Class B digital device, pursuant to part 15 of the FCC Rules. These limits are designed to provide reasonable protection against harmful interference in a residential installation. This equipment generates uses and can radiate radio frequency energy and, if not installed and used in accordance with the instructions, may cause harmful interference to radio communications. However, there is no guarantee that interference will not occur in a particular installation. If this equipment does cause harmful interference to radio or television reception, which can be determined by turning the equipment off and on, the user is encouraged to try to correct the interference by one or more of the following measures:

—Reorient or relocate the receiving antenna.

—Increase the separation between the equipment and receiver.

—Connect the equipment into an outlet on a circuit different from that to which the receiver is connected.

—Consult the dealer or an experienced radio/TV technician for help.

Privacy of communications may not be ensured when using this telephone!