



GWN7600

Wireless Access Point

To ensure easy installation and management, the GWN7600 uses a controller-less distributed network management design in which the controller is embedded within the product's web user interface. This allows each access point to manage a network of up to 30 GWN76xx series APs independently without needing separate controller hardware/software and without a single point-of-failure. This wireless access point can be paired with any third party routers as well as Grandstream GWN series routers. With support for advanced QoS, low-latency real-time applications, 450+ concurrent client devices per AP and dual Gigabit network ports with PoE, the GWN7600 is an ideal WiFi access point for medium wireless network deployments with medium-to-high user density.



Gigabit

1.17Gbps wireless throughput and 2x Gigabit wireline ports



PoE

Support 802.3af Power-over-Ethernet (PoE)



Support 450+ concurrent WiFi client devices



Advanced QoS to ensure real-time performance of low-latency applications



165 meters

Up to 165-meter coverage range



Anti-hacking secure boot and critical data/control lockdown via digital signatures, unique security certificate/random default password per device



Embedded controller allows GWN7600 to auto-discover, auto-provision and manage up to 30 GWN7600s in a network

Specifications

WiFi Standards	IEEE 802.11 a/b/g/n/ac (Wave-2)
Antennas	2x 2.4 GHz, gain 3 dBi, internal antenna 2x 5 GHz, gain 3 dBi, internal antenna
WiFi Data Rates	IEEE 802.11ac: 6.5 Mbps to 877 Mbps IEEE 802.11a: 6, 9, 12, 18, 24, 36, 48, 54 Mbps IEEE 802.11n: 6.5 Mbps to 300 Mbps IEEE 802.11b: 1, 2, 5.5, 11 Mbps IEEE 802.11g: 6, 9, 12, 18, 24, 36, 48, 54 Mbps <i>*Actual throughput may vary depending on many factors including environmental conditions, distance between devices, radio interference in the operating environment and mix of devices in the network</i>
Frequency Bands	2.4GHz radio : 2.412 - 2.462 GHz 5GHz radfio: 5.150 - 5.250 GHz, 5.725-5.850 GHz
Channel Bandwidth	2.4G: 20 and 40 MHz 5G: 20,40 and 80 MHz
WiFi and System Security	WEP, WPA/WPA2-PSK, WPA/WPA2 Enterprise (TKIP/AES), anti-hacking secure boot and critical data/control lockdown via digital signatures, unique security certificate and random default password per device
MIMO	2x2:2 2.4GHz (MIMO), 2x2:2 5GHz (MU-MIMO)
Coverage Range	Up to 541 ft. (165 meters)
Maximum TX Power	5G: 802.11a:22.53dBm,802.11n-HT20:22.36dBm;802.11n-HT40:22.38dBm;802.11ac20:22.34dBm 802.11ac40:22.30dBm;802.11ac80:22.15dBm; 2.4G: 802.11b:20.14dBm;802.11g:22.40dBm,802.11n-HT20:22.14dBm;802.11n-HT40:22.0dBm;
Receiver Sensitivity	2.4G 802.11b:-99dBm @1Mbps,-91dBm @11Mbps;802.11g:-93dBm @6Mbps,-75dBm @54Mbps; 80.11n 20MHz:-72dBm @MCS7;802.11n 40MHz:-69dBm @MCS7 5G 802.11a:-91dBm @6Mbps,-74dBm @54Mbps;802.11ac 20MHz:-67dBm @MCS8;802.11ac HT40:-63dBm @MCS9;802.11ac 80MHz:-60dBm @MCS92
SSIDs	16 SSIDs per radio
Concurrent Clients	450+
Network Interfaces	2x autosensing 10/100/1000 Base-T Ethernet Ports
Auxiliary Ports	1x USB 2.0 port, 1x Reset Pinhole, 1x Kensington lock
Mounting	Indoor wall mount or ceiling mount, kits included
LEDs	3 tri-color LEDs for device tracking and status indication
Network Protocols	IPv4, 802.1Q, 802.1p, 802.1x, 802.11e/WMM
QoS	802.11e/WMM, VLAN, TOS
Network Management	Embedded controller in GWN7600 allows it to auto-discover, auto-provision and manage up to 30 GWN7600s in a network
Power and Green Energy Efficiency	DC Input: 24VDC/1A Power over Ethernet (802.3af) compliant Maximum Power Consumption:13.8W
Environmental	Operation:-20°C to 40°C Storage: -10°C to 60°C Humidity: 10% to 90% Non-condensing
Physical	Unit Dimension: 205.3 x 205.3 x 45.9mm; Unit Weight: 526g Unit + Mounting Kits Dimension : 205.3 x 205.3 x 53.9mm; Unit + Mounting Kits Weight : 610g Entire Package Dimension: 228.5 x 220 x 79mm; Entire Package Weight: 854g
Package Content	GWN7600 Wave-2 802.11ac Wireless AP, Mounting Kits, Quick Start Guide
Compliance	FCC, CE, RCM, ISEDC

OVERVIEW

To ensure easy installation and management, the GWN7600 uses a controller-less distributed network management design in which the controller is embedded within the product's web user interface. This allows each access point to manage a network of up to 30 GWN7600 series APs independently without needing separate controller hardware/software and without a single point-of-failure. This wireless access point can be paired with any third party routers as well as Grandstream GWN series routers. With support for advanced QoS, low-latency real-time applications, 450+ concurrent client devices per AP and dual Gigabit network ports with PoE, the GWN7600 is an ideal WiFi access point for medium wireless network deployments with medium-to-high user density.

PRECAUTIONS

- Do not attempt to open, disassemble, or modify the device.
- Do not expose this device to temperatures outside range of -20°C to 40 °C.
- Do not expose the GWN7600 to environments outside of the following humidity range: 10-90% RH (non-condensing).
- Do not power cycle your GWN7600 during system boot up or firmware upgrade. You may corrupt firmware images and cause the unit to malfunction.

PACKAGE CONTENTS

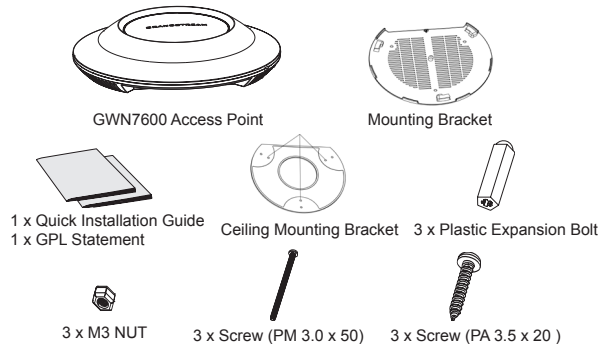

GWN7600 PORTS

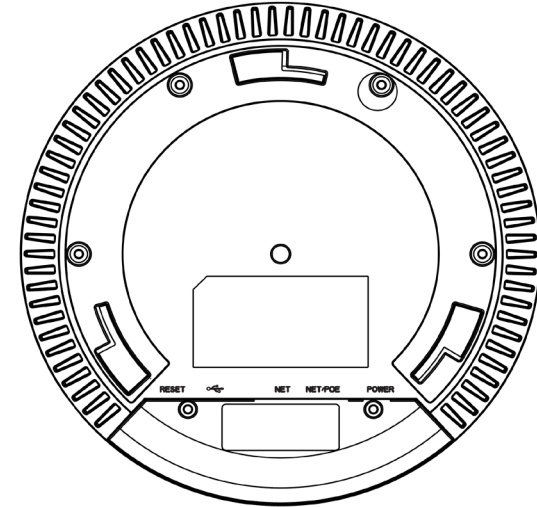

Port	Description
POWER	Power adapter connector (DC24V, 1A) Note: Power adapter is not provided.
NET/POE	Ethernet RJ45 port (10/100/1000Mbps) supporting PoE.
NET	Ethernet RJ45 port (10/100/1000Mbps) to your router or another GWN76xx.
	USB 2.0 port (for future IOT & location based applications)
RESET	Factory reset button. Press for 7 seconds to reset factory default settings.

HARDWARE INSTALLATION

GWN7600 can be mounted on the wall or ceiling, Please refer to the following steps for the appropriate installation.

Wall Mount

1. Position the mounting bracket at the desired location on the wall with the arrow pointing up.
2. Use a pencil to mark the four mounting holes (screw holes DIA 5.5mm, reticle hole DIA 25mm).

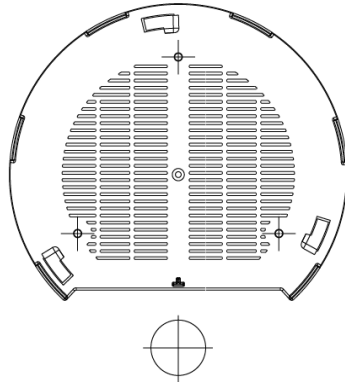

3. Insert screw anchors into the 5.5 mm holes. Attach the mounting bracket to the wall by inserting the screws into the anchors.

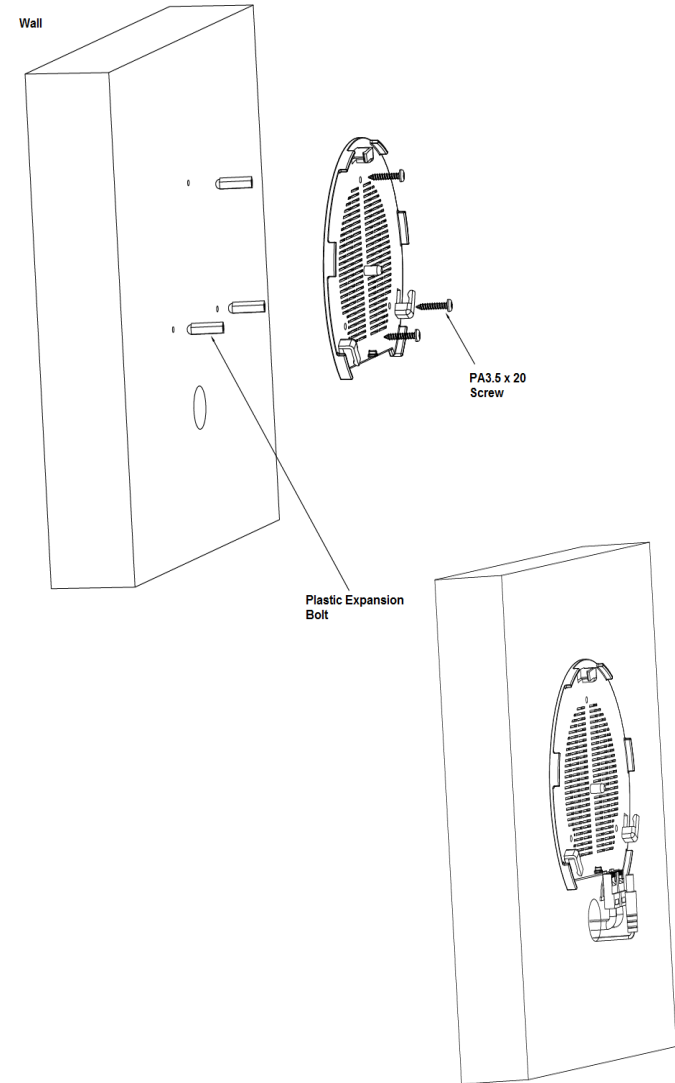

4. Connect the power cable and the ethernet cable (RJ45) to the correct ports of your GWN7600.

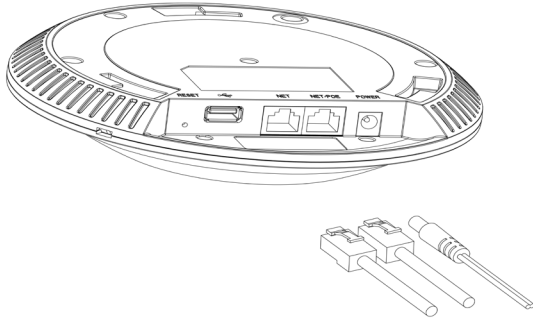

5. Align the arrow on the GWN7600 with the arrow on the locking tab of the mounting bracket and ensure that your GWN7600 is firmly seated on the mounting bracket.

6. Turn the GWN clockwise until it locks into place and fits the locking tab.

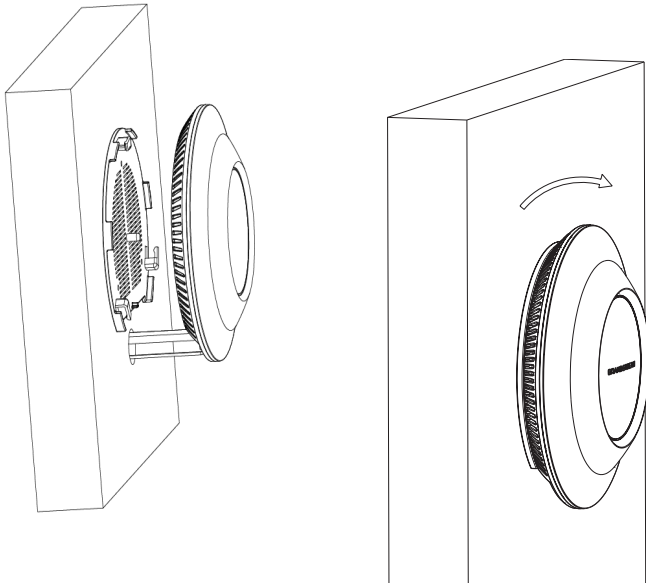

Ceiling Mount

1. Remove the ceiling tile.
2. Place the ceiling backing plate in the center of the ceiling tile and mark the mounting screw holes (screw holes DIA 5.5mm, reticle hole DIA 25mm).

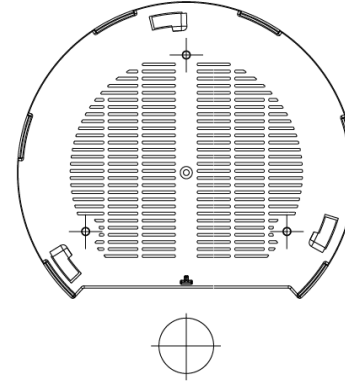

3. Insert the screws through the mounting bracket.

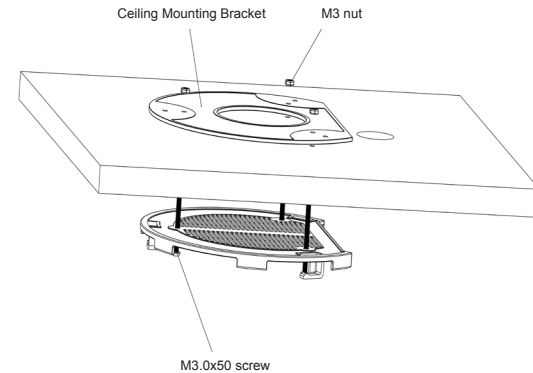

4. Connect the power cable and the Ethernet cable (RJ45) to the correct ports of your GWN7600.

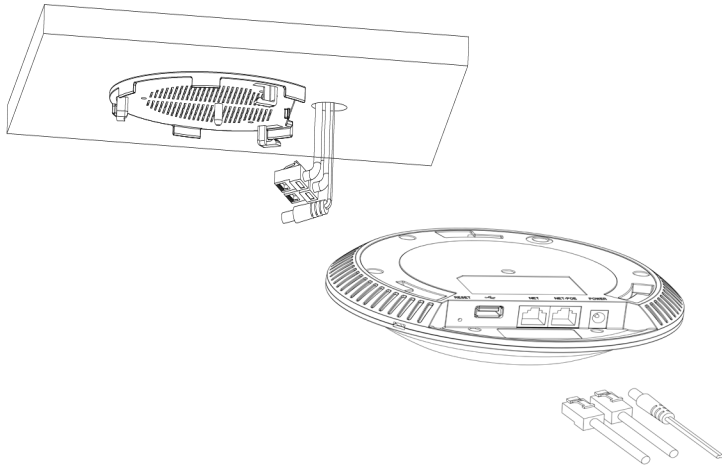

5. Align the arrow on the GWN7600 with the arrow on the locking tab of the mounting bracket and ensure that your GWN7600 is firmly seated on the mounting bracket and connect the network and power cables.

6. Turn the GWN clockwise until it locks into place and fits the locking tab.

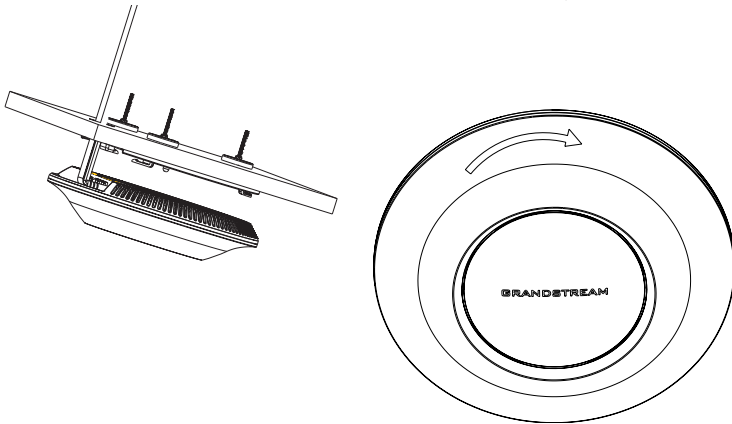

Note: Ceiling mounting is recommended for optimal coverage performance.

POWERING AND CONNECTING THE GWN7600

GWN7600 can be powered on using PoE switch using following steps:

Step 1: Plug a RJ45 Ethernet cable into the network port of the GWN7600

Step 2: Plug the other end into the uplink port of the power over Ethernet (PoE) switch.



Network
Port

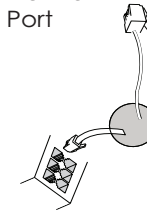

RJ45 Ethernet Cable
to Power over Ethernet
(PoE) Switch

CONNECT TO GWN7600 DEFAULT WIFI NETWORK

GWN7600 can be used as standalone access point out of box, or after factory reset with Wi-Fi enabled by default.

After powering the GWN7600 and connecting it to the network, GWN7600 will broadcast a default SSID based on its MAC address **GWN[MAC's last 6 digits]** and a random password.

Note: GWN7600's default SSID and password information are printed on the MAC tag of the unit.

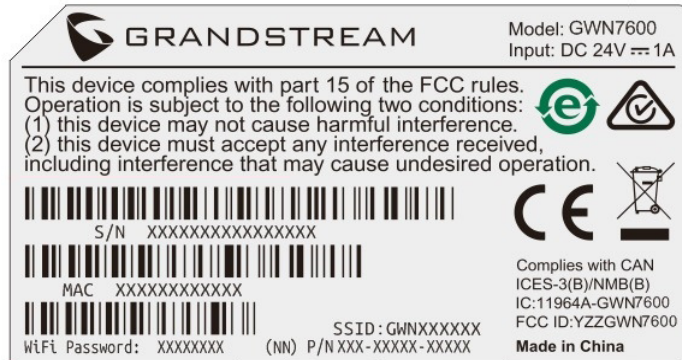

ACCESSING THE CONFIGURATION INTERFACE

A computer connected to the GWN7600's SSID, or to the same network as the GWN7600 can discover and access its configuration interface using one of the below methods:

Method 1: Discover GWN7600 using its MAC Address.

1. Locate the MAC address on the MAC tag of the unit, which is on the underside of the device, or on the package.
2. From a computer connected to same network as the GWN7600, type in the following address using the GWN7600's MAC address on your browser **https://gwn_<mac>.local**
Example: if a GWN7600 has the MAC address 00:0B:82:8B:4E:28, this unit can be accessed by typing **https://gwn_000b828b4e28.local** on the browser.

Method 2: Discover GWN7600 using GWN DiscoveryTool.

1. Download and install **GWN DiscoveryTool** from the following link:

http://www.grandstream.com/support/tools

2. Open the GWN DiscoveryTool, and click on **Scan**.
3. The tool will discover all GWN7600 Access Points connected on the network showing their MAC and IP addresses.
4. Click on **Manage Device** to be redirected directly to the GWN7600's configuration interface, or type in manually the displayed IP address on your browser.

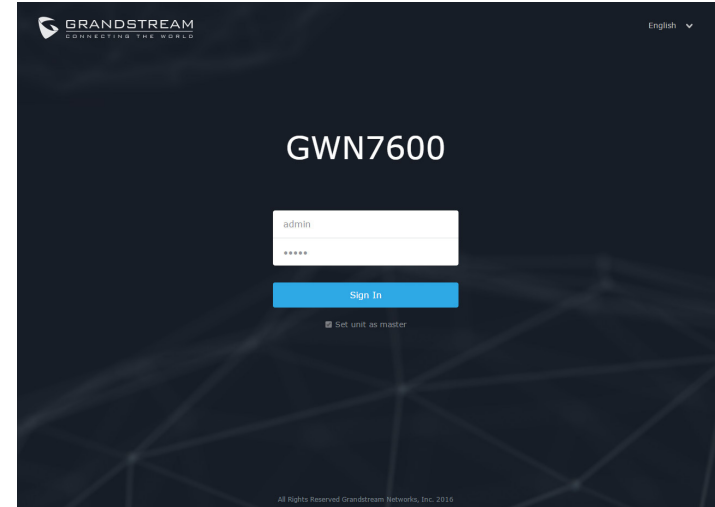

Using one of the above methods, the login screen will appear. Type in "admin" in both Username and Password fields and click on **Sign In**.

Notes :

- Make sure that the GWN7600 is not already paired with another GWN7600/GWN7610 Access Point as slave, otherwise the configuration interface cannot be accessed.
- If the GWN7600 is already paired, make sure to unpair it first, or do a factory reset.
- For more information, please download the GWN7600 User Manual from: **http://www.grandstream.com/support**

FCC Caution:

Any Changes or modifications not expressly approved by the party responsible for compliance could void the user's authority to operate the equipment.

This device complies with part 15 of the FCC Rules. Operation is subject to the following two conditions: (1) This device may not cause harmful interference, and (2) this device must accept any interference received, including interference that may cause undesired operation.

Note: This equipment has been tested and found to comply with the limits for a Class B digital device, pursuant to part 15 of the FCC Rules. These limits are designed to provide reasonable protection against harmful interference in a residential installation. This equipment generates, uses and can radiate radio frequency energy and, if not installed and used in accordance with the instructions, may cause harmful interference to radio communications. However, there is no guarantee that interference will not occur in a particular installation. If this equipment does cause harmful interference to radio or television reception, which can be determined by turning the equipment off and on, the user is encouraged to try to correct the interference by one or more of the following measures:

- Reorient or relocate the receiving antenna.
- Increase the separation between the equipment and receiver.
- Connect the equipment into an outlet on a circuit different from that to which the receiver is connected.
- Consult the dealer or an experienced radio/TV technician for help.

FCC Radiation Exposure Statement:

This equipment complies with FCC radiation exposure limits set forth for an uncontrolled environment. This equipment should be installed and operated with minimum distance 20cm between the radiator & your body.

This transmitter must not be co-located or operating in conjunction with any other antenna or transmitter.