



Grandstream Networks, Inc.

GXV3651 Series User Manual

Safety Instructions

These instructions are intended to assist users with the operation of the GXV3651 and also to instruct on how to avoid dangerous situations or damage to the device.

Warnings: Serious injury or death may be caused if any of the warnings below are neglected.

Cautions: Injury or damage to the equipment may occur if any of the following caution messages are neglected.



Warnings Follow these safeguards to prevent serious injury or death.



Cautions Follow these precautions to prevent potential injury or material damage.



Warnings:

Input voltage should meet both the SELV (Safety Extra Low Voltage) and the Limited Power Source with DC 12V according to the IEC60950-1 standard. Please refer to the technical specifications for more details.

Do not use a third-party power adapter or power cord

When the device is installed on the wall or ceiling, make sure that it is firmly attached.



Notice:

Make sure that the power supply voltage is correct before using the camera.

Do not drop the device or expose it to physical shock.

Do not expose the device to temperatures outside the range of -10 °C to +60°C when the device is in operation.

Do not expose the device to damp/wet conditions or high electromagnetism radiation.

To avoid heat accumulation, make sure that your operating environment has proper ventilation.

Do not attempt to open, disassemble, or modify the device

A few parts (e.g. electrolytic capacitor) of the equipment shall be replaced regularly according to their average life time. The average life time varies from the differences between operating environments and usage history. Regular maintenance checks are recommended for all users. Please contact your dealer for more details.

Contents

Welcome	4
Package Contents	5
Product Overview	6
GXV3651 Overview	6
GXV3651 Back Panel.....	6
GXV3651 Sample Connection Diagram.....	7
GXV3651 Key Features.....	7
GXV3651 Lens Specification	8
Minimum Recommended System Requirement	10
Connect your GXV3651	10
Configuring the GXV3651 via Web Browser	11
Access GXV3651 Web Configuration Menu.....	11
Connect the Camera to DHCP server.....	11
Connect to the Camera using Static IP.....	12
GXV3651 Home Web Page	13
GXV3651 System Page	14
GXV3651 Video & Audio Page.....	15
GXV3651 Networking Page – Assign an IP to GXV3651	17
GXV3651 DDNS Page	18
GXV3651 SIP Page	18
GXV3651 Status Page	20
GXV3651 User Management Page.....	21
GXV3651 Maintenance Page	22
GXV3651 SMTP Page.....	23
GXV3651 FTP Page	23
GXV3651 PTZ Page.....	24
GXV3651 Alarm Event.....	25
GXV3651 Motion Detection Page.....	28
Configure Motion Detection & Alarm Actions.....	29
GXV3651 System Log.....	29
FAQ.....	30

Welcome

The GXV3651 series is a next generation High Definition IP camera of power and innovation. It's for remote monitoring and surveillance over your LAN or internet.

The innovative AE (Auto Exposure) & AWB (Auto White Balance) algorithms power the advanced ISP (Image Sensor Processor), ensure high-fidelity video qualities and match Digital Still Camera color grade in wide range of light environments.

It features cutting edge H.264 real-time video compression (1080p resolution) with excellent image clarity at low-to-modest bandwidth, industry leading SIP/VoIP for full duplex 2-way audio and video streaming to mobile phones and video phones, integrated PoE, embedded analytics, large pre-/post-event recording buffer, and advanced security protection. Its unique incorporation of the most comprehensive peripheral support for alarm control, local storage expansion, and wireless network connection, creates sophisticated and best-in-class control flexibility and scalability.

The GXV3651 can be managed with GSurf, Grandstream's advanced and intuitive video management software that controls up to 36 cameras simultaneously. It offers an HTTP API and has open-standard Onvif conformance for easier operation and higher levels of integration.

The GXV3651 is a powerful network camera for professional surveillance environments.

Package Contents

Items in the package:

- GXV3651 IP Camera
- 12V DC power Adapter
- 6-pin terminal block connector – 6-pin connector block for connecting external devices, such as infrared detector, smoke detector and etc., to Alarm IN, Alarm OUT and RS485 pins.
- Quick installation guide

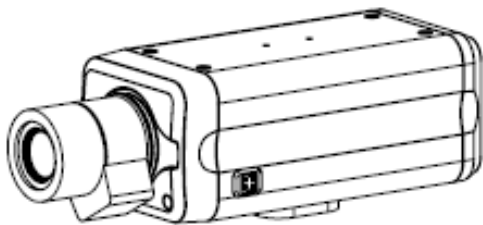

GXV3651



POWER ADAPTER



GREEN WIRE CRAMPER

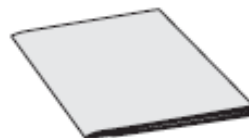

QUICKSTART GUIDE

Product Overview

GXV3651 Overview



TABLE 1: GXV3651 PRODUCT MODELS

Model	P/N
GXV3651_HD	xxx-xx009-xxx
GXV3651_FHD	xxx-xx0011-xxx

Note: The main difference between GXV3651_HD and GXV3651_FHD is the Max frame rate and the Max resolution.

GXV3651 Back Panel

Indicators and Connectors on Back Panel

NETWORK – 10/100 Switch LAN port for connecting to Ethernet. The indicator will be steady for connection and flashing for network activity.

AUDIO IN – 3.5mm port for audio input devices (microphone, pickup and etc.).

AUDIO OUT – 3.5mm port for audio output devices (speakers, and etc.).

VOUT – 1 BNC (Voltage: 1.0V p-p, Resistance 75Ω) port for video output. This is only applicable on GXV3651-N/GXV3651-LL.

DC 12V – 12V DC power jack; UL Certified.

SD/MMC – SD card slot.



RESET – Press the Reset button for 6 seconds to perform a factory reset.

PINS – 1 PTZ connector, Alarm In connector, and Alarm out connector.

USB – USB connector for USB flash/hard drives.

POWER – The indicator will be **solid green** if the power is on.

GXV3651 Sample Connection Diagram

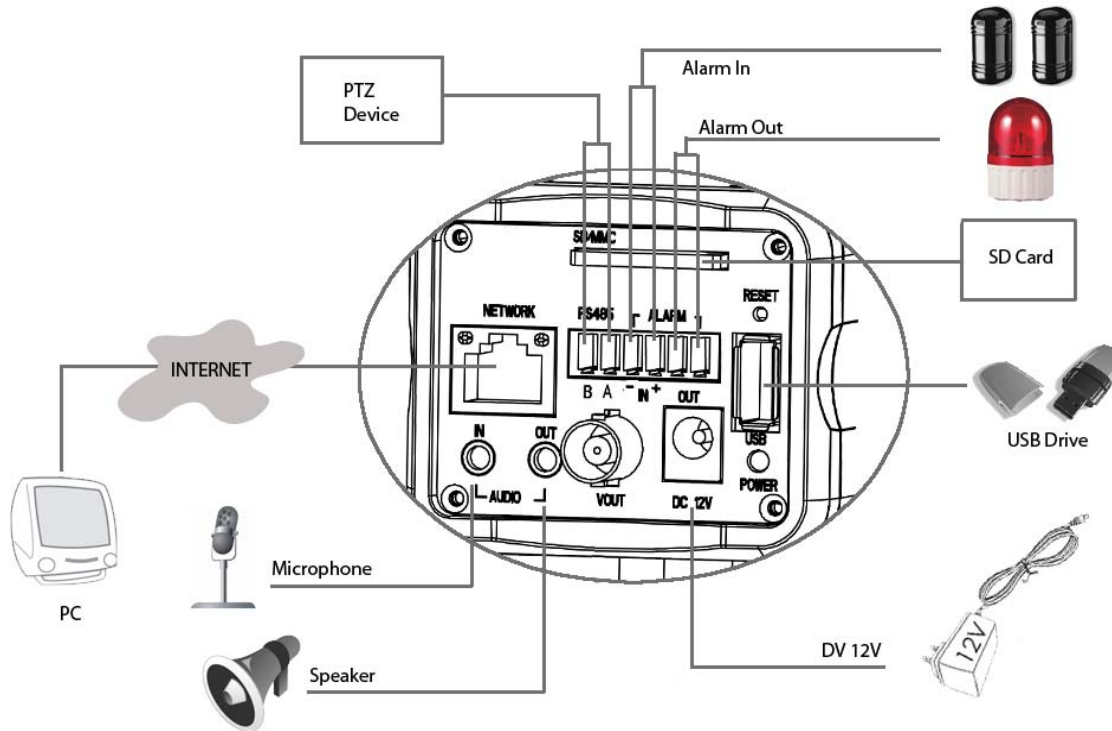

GXV3651 Key Features

The table below lists the key features the GXV3651 Supports.

Model	GXV3651_HD	GXV3651_FHD
Video Compression	H.264, Motion JPEG	
Image Sensor	1/2.5", 5-Megapixel CMOS, 2592H x 1944V	
Lens Type	1/2", Mega, DC-Iris (Optional)	
Day & Night	yes, Light sensor, Mechanical IR-Cut	
Responsivity	1.4V/lux-sec (550nm)	
Max Resolution	1920x1080;1600x1200;1280x960;1280x720;1024x768;800x592;800x480;640x480;640x368;480x368;480x272;320x240;320x176;256x192;256x144	2560x1920;2048x1536;1920x1080;1600x1200;1280x960;1280x720;1024x768;800x592;800x480;640x480;640x368;480x368;480x272;320x240;320x176;256x192;256x144

		30fps @ 1920x1080;1600x1200; 60fps @1280x960;1280x720;
Bit rate	32 Kbps – 10 Mbps	
Video output	BNC, Voltage 1.0Vp _p , Resistance 75Ω	
Audio input	3.5mm LINE-IN, built-in Microphone	
Audio output	3.5mm LINE-OUT	
Audio Input	3.5mm LINE-IN, built-in Microphone	
Audio Output	3.5mm LINE-OUT	
Alarm Input	$V_{IN} \leq 45V$, $I_{IN} \leq 25mA$	
Alarm Output	125VAC/0.5A, 30VDC/2A, Normal Open	
IRIS Control	Selectable Auto-IRIS or Manual-IRIS	
Embedded Analytics	Motion detection (up to 16 target areas), video loss (pending)	
Pre-/post-alarm Buffer	24MB	
Snapshots	Trigger upon events, send via email/FTP	
Multi-streaming-rate for Preview & Recording	Yes	
Security	Video watermark (pending), HTTPS, admin/anonymous	
Network Protocol	TCP, UDP, IP, HTTP, DHCP, RTP, RTSP, FTP, SMTP, DNS, DDNS, NTP, ICMP, IGMP, ARP, SIP	
Power over Ethernet (PoE)	IEEE 802.3af default class	
Peripheral Ports	SD 2.0, USB 2.0	
SIP/VoIP Support	Yes	
Dimensions (L x W x H)	164mm x 68mm x 64mm	
Weight	0.6kg	
Temperature / Humidity	0°C – 45°C (32°F–133°F) Humidity 10–90% RH (non-condensing)	
Power Adapter	Output: 12VDC/1A; Input: 100–240VAC, 50–60Hz	
Compliance	FCC ; CE ; C-tick	

GXV3651 Lens Specification

G XV3651 LENS SPECIFICATIONS

Lens Mount	CS
Resolution	3 Megapixel
Image Format	1/2"
Image Sensor	CCD/CMOS
Focal Length	4.5~10 mm
Back Focal Length	6.79~11.8 mm
View Angles (F.O.V)(W~T)(D/H/V)	102° ~ 46.5°/80.5°~37° /60°~28°
Aperture	1.6
Effective Aperture	Front: 19.8 mm Rear: 9.3 mm
M.O.D	0.10m
Iris	Manual

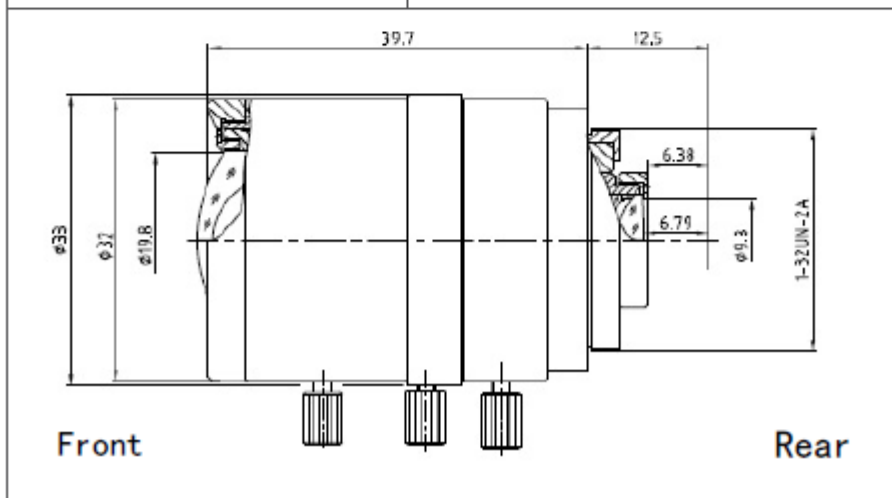

Installation Guide

Minimum Recommended System Requirement

- Windows 2000 Server Professional, Windows XP, Windows Vista.
- CPU: Intel Pentium 4 or higher, 2 GHz.
- RAM: 1 GB (4 GB recommended for larger systems).
- Support for DirectX 8.0 and above.

Connect your GXV3651

Using the Power adapter as power supply

- Connect an RJ-45 cable to the NETWORK port of the GXV3651.
- Connect the other end of the RJ-45 cable to your network or PC.
- Connect the power supply to the DC 12V power jack on the back of the GXV3651.
- Connect the other end of the power supply to a wall outlet. The POWER LED will turn solid green.

Using PoE as power supply:

- Connect an RJ-45 to the NETWORK port of GXV3651.
- Connect the other end of the RJ-45 cable to a PoE switch. The POWER indicator will turn solid green.

NOTE: If you are going to connect the device to a hub/switch/router, please use a straight-through cable. A cross over cable should be used if you are going to connect the device directly to a PC.

Configuring the GXV3651 via Web Browser

The GXV3651's embedded Web server responds to HTTP/HTTPS GET/POST requests. Embedded HTML pages allow you to configure your IP camera through Microsoft Internet Explorer.

Access GXV3651 Web Configuration Menu

Connect the Camera to DHCP server.

1. Navigate your browser to:
http://www.grandstream.com/support/gxv_series_surveillance/general/resources/gsearch.zip
2. Run the Grandstream GS_Search tool, that you just downloaded.
3. Click on button in order to begin device detection
4. The detected devices will appear in the Output field

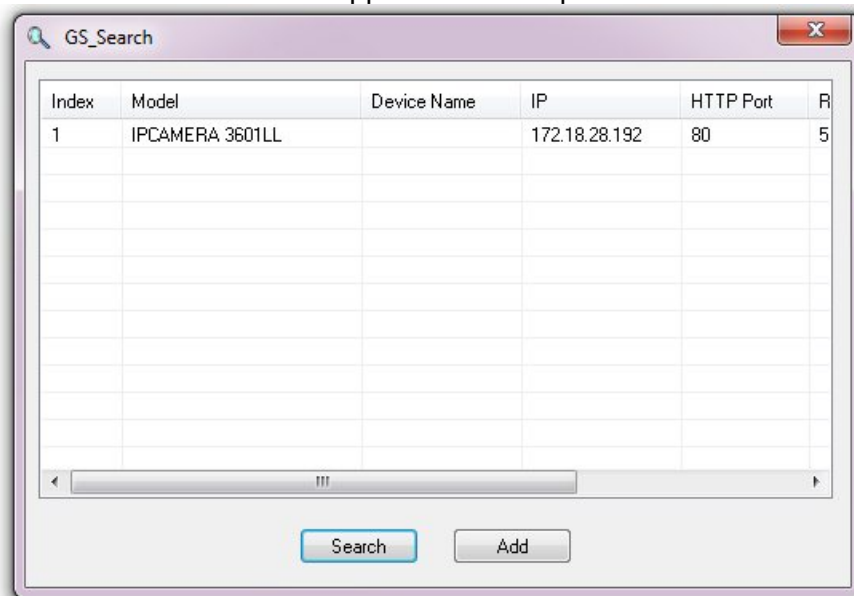

5. Start Internet Explorer on your computer.
6. Enter device IP in the address bar of the browser.
7. Enter the administrator user name and password to access the Web Configuration Interface
8. The default user name and password are both set to **admin**.
9. IE will indicate that "This website wants to install the following add-on: 'GSViewerX.cab' from 'Grandstream Networks Inc'." Install this add-on by following the instructions in IE.
10. You will see the home page.

Connect to the Camera using Static IP.

If the camera does not get response from DHCP server after 3 minutes, it can be accessed by the default IP 192.168.1.168.

1. Connect your PC to the same network as the GXV3651.
2. Configure the IP address of your PC to: 192.168.1.XXX (1<XXX<255) and configure the subnet mask to 255.255.255.0.
3. Make sure that the device is turned on and connected to the network.
4. Start Internet Explorer on your computer.
5. Enter 192.168.1.168 in the address bar of the browser.
6. Enter the administrator user name and password to access the Web Configuration Interface
7. The default user name and password are both set to admin.
8. IE will indicate that "This website wants to install the following add-on: 'GSViewerX.cab' from 'Grandstream Networks Inc'." Install this add-on by following the instructions in IE.
9. You will see the home page.

GXV3651 Home Web Page

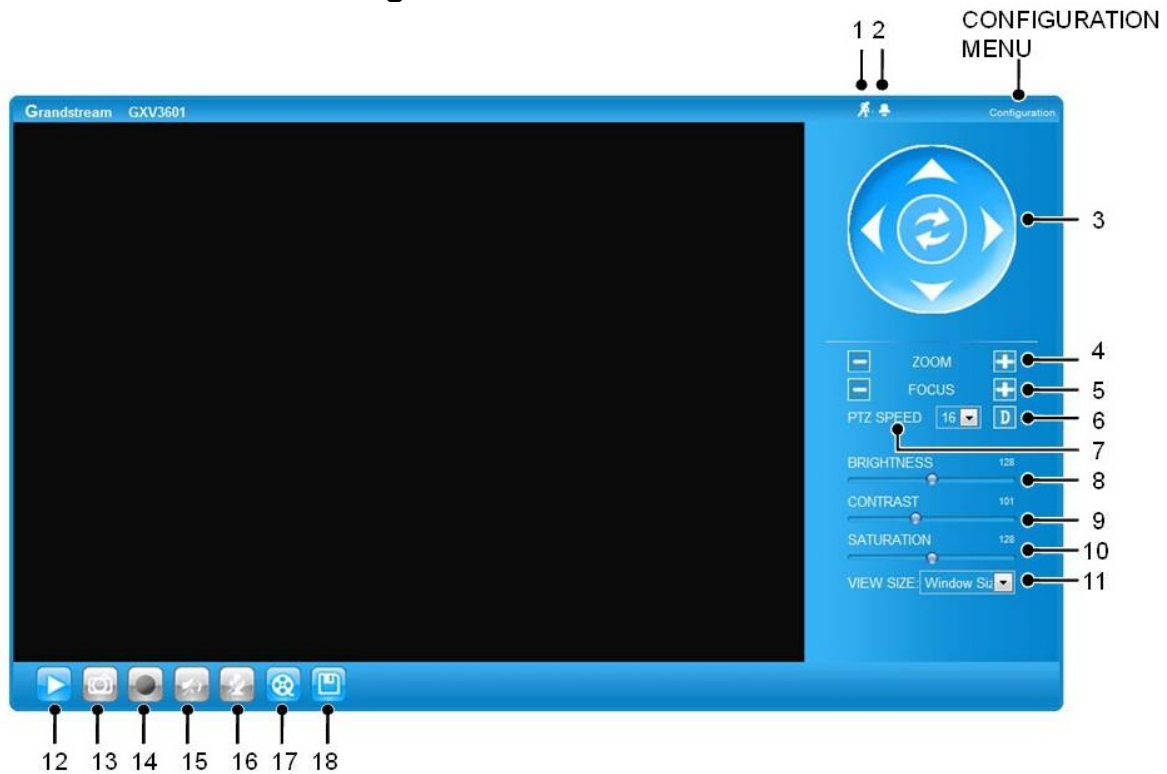

Figure2: Home web page of GXV3651-N and GXV3651-LL

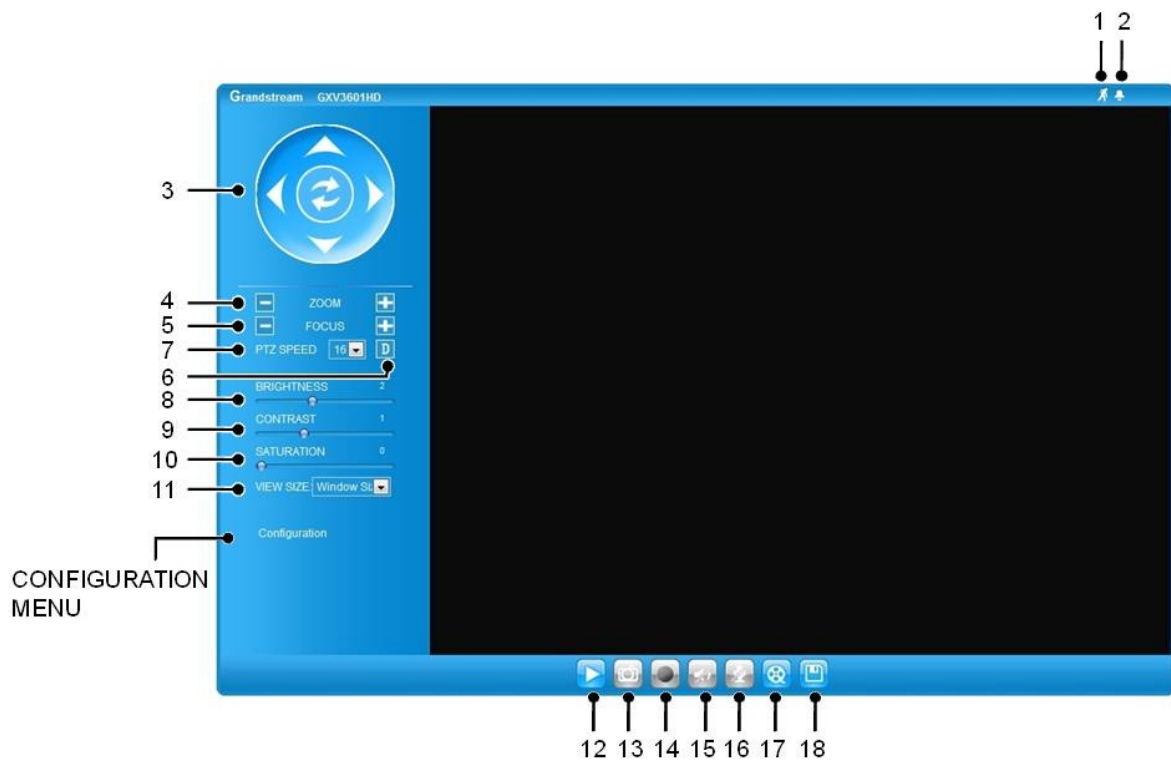

Figure3: Home web page of GXV3651

Items on GXV3651 Home Page

- | | | |
|-----------|-------------------------|---|
| 1 | Motion Detection | If the motion detection alarm is triggered, the indicator will flash red . Click on the indicator to turn off the alarm. |
| 2 | Alarm Event | If an alarm event is triggered, the indicator will flash red . Click on the indicator to turn off the alarm. |
| 3 | Control Console | PTZ Console controller. PTZ device needs to be connected. |
| 4 | ZOOM | NOTE: GXV3651 does not support zoom |
| 5 | FOCUS | Adjusts the focus of images. |
| 6 | Default | Click this option to reset the video brightness, contrast, and saturation to their factory default configuration. |
| 7 | SPEED | Adjusts the rotation speed of the console. |
| 8 | BRIGHTNESS | Adjusts the image brightness. |
| 9 | CONTRAST | Adjusts the image contrast. |
| 10 | SATURATION | Adjusts the image saturation. |
| 11 | View Size | Resize the image to fit into the window panel in the home screen. |
| 12 | Play | Plays/Stops the video. |
| 13 | Capture | Captures the image displayed and saves it to C:\GS_Capture (default directory). |
| 14 | Record | Records the video and saves it to C:\GS_Record (default directory). |
| 15 | Sound Off/On | Toggles the sound On or Off. |
| 16 | Talk | Establishes two-way audio. |
| 17 | Playback | Replays the saved video. |
| 18 | Config | Configures the Save Location for captured images and recorded videos. |

GXV3651 System Page

This page allows you to configure the system settings on GXV3651.

Current System Time - displays the current date and time (24h clock).

Current System Time

Date:

Time:

Set the System Time

Update via NTP Server

- the camera will obtain the time from an NTP server Specify the NTP server's IP address or

Set the System Time

Time Zone:

Update via NTP Server

Synchronize with Local Computer

Set the Time Manually

Keep Current Date and Time

Firmware 1.0.4.6

Grandstream Networks, Inc. 09/2010

host name. And you can select your time zone from the drop-down list or define your own time zone setting.

NOTE: If using a host name for the NTP server, a DNS server must be configured under **Basic Settings -> Networking**.

Synchronize with Local Computer - sets the time from the clock on your computer.

Set the Time Manually - this option allows you to manually set the time and date.

OSD Date Format - set the format of date on OSD

OSD Date Format

OSD Date Format:

Device Name Setting -This field lets you configure the name of the GXV3651, which helps

Device Name Setting

Device Name:

GSurf and GS_NVR to identify the device when using **GS_Search** to search all the Grandstream network cameras or digit video cameras in the same subnet.

DI and DO - Digital input and digital output

Normal open: the circuit is by default open unless an event triggers the device to close the circuit.

Normal close: the circuit is by default closed unless and event triggers the device to open the circuit

DI and DO

Digital input: ; the current state detected is **Open**

Digital output: ; the current state detected is **Open**

GXV3651 Video & Audio Page

On Screen Display (OSD) Settings

OSD Time/ Text – The time stamp and channel name displayed on the screen.

On Screen Display(OSD)

OSD Text:

OSD Position:

OSD Transparency:

OSD Color:

Display Time:

Display Text:

Video Settings

Preferred Video Codec – The GXV3651 supports the H.264 video codec.

Resolution – The higher the resolution is, the better the video quality is, and higher bandwidth is required.

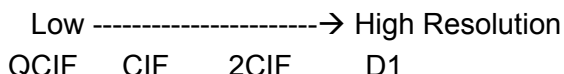

Bit Rate – The number of bits that are conveyed or processed per unit of time.

Maximum Frame Rate – The video frame rate is adjustable based on network conditions. *Increasing the frame rate will increase the amount of data significantly therefore consuming more bandwidth.* Video will be impaired due to packet loss when there is insufficient bandwidth.

Video Settings

Preferred Video Codec: H264

Resolution: D1 704*480

Bit Rate: 1024 kbps

Maximum Frame Rate: 30 fps

Bit Rate Control: CBR VBR

I-frame Interval: 30 Frame(1-100)

Bit Rate Control – Variable Bit rate (VBR) and Constant Bit Rate (CBR).

Variable Bit Rate - If VBR is selected, the codec varies the amount of output data per time segment. VBR produces a better quality-to-space ratio. The bits available are used to enable more flexibly and encode sound or video data more accurately, with fewer bits used in less demanding passages and more bits used in difficult-to-encode passages.

Constant Bit Rate - If CBR is selected, the codec’s output data is constant regardless of the input data. The output bit rate is defined in “Bit rate”. CBR is useful for streaming multimedia content on limited capacity channels. It is easier to calculate required bandwidth as well as the required storage space using CBR.

Image Quality – If ‘Bit Rate Control’ is set to “VBR”, “Image quality” needs to be configured. The better the video quality is, the higher the bit rate will be.

I-frame Interval – While streaming video over a network, compression technologies are used to show the incremental difference between each frame. I-frames are used to help keep the video looking normal. When intervals are shorter, the video quality is higher but uses more bandwidth.

NOTE: The users might need to configure the **Primary Stream** and **Secondary Stream** properly. Sometimes, the user might like to watch the live video stream from the web GUI in low resolution mode while recording a copy via GSurf/GS_NVR in high resolution due to the limitation of internet bandwidth. In this case, for example, primary stream can be configured to have better resolution, and then the users can use primary stream to record while watching secondary video streams.

Audio Settings

Preferred Audio Codec – The GXV3651 supports up to 3 different Vocoder types, a-law (PCMA), u-law (PCMU) and G.726. The audio can also be turned off by switching the setting to “Disabled”

Audio Compression – Audio

Audio Settings

Preferred Audio Codec: PCMA

Audio Compression: 32 kbps

compression is a form of data compression designed to reduce the size of audio files. Usually, the higher the audio compression is, the better the audio quality is.

Power Frequency - this setting should match the power frequency used in the country to avoid flickering in the image. And it is only available for GXV3651HD

Power Frequency

Power Frequency: Hz

GXV3651 Networking Page – Assign an IP to GXV3651

GXV3651 supports IP version 4. The IP address can set automatically via DHCP, or a static IP address can be set manually. To make GXV3651 work properly, the user needs to set the DNS configuration properly. For security purposes, the user can also assign the GXV3651 an HTTP Port other than 80.

IP Address Configuration

The GXV3651 operates in two modes:

Dynamically Assigned via DHCP

– all the field values for the Static IP mode are not used. The GXV3651 acquires its IP address from the first DHCP server it discovers on its LAN.

Statically Configured as –

configures all of the following fields: IP address, Subnet Mask, Default Gateway IP address, DNS Server 1

(primary), DNS Server 2 (secondary). These fields are set to zero by default. *Static IP addresses are recommended for the GXV3651*

IP Address Configuration

Dynamically Assigned via DHCP

Statically Configured as:

IP Address:

Subnet Mask:

Default Gateway:

DNS Configuration

There are two methods of DNS configuration on the GXV3651:

1. The GXV3651 can obtain the DNS server automatically
2. Users can configure their own preferred DNS server

DNS Configuration

Obtain DNS Server Address Automatically

Use the Following DNS Server Address:

Primary DNS Server:

Secondary DNS Server:

HTTP Port

The GXV3651 supports user configured http ports. If the HTTP port is changed, the

HTTP

HTTP Port:

port number is needed to access the web GUI, for instance: <http://192.168.1.168:8080>.

NOTE: If the HTTP Port is 80, when you add this device to GSurf or GS_NVR, the RTSP port is 554. If the HTTP Port is changed, when you add this device to GSurf or GS_NVR, please make sure the RTSP port number equals HTTP Port plus 2000.

GXV3651 DDNS Page

Dynamic DNS provides devices that have a variable, often changing IP address with a well known hostname resolvable by network applications through standard DNS queries.

Set up DDNS

1. Apply for a domain name from your service provider.
2. Login to the web configuration page, click **Basic Settings > DDNS**.
3. Enter the required information

DDNS Active – If you want to use DDNS, please set this field to “Enabled” .
DDNS ISP Type – Select your DDNS ISP Type.

Self-Define DDNS Address – Self-define the DDNS server instead of using DDNS ISP Type.

Site Name – The DDNS name for your device.

DDNS Account/ DDNS Password – The account and password from the DDNS Provider.

STUN Server – If the device is behind a router, a STUN server is needed to help penetrate the NAT.

4. Click **Save** to save the changes. You might need to reboot the device to apply all the changes.

GXV3651 SIP Page

The GXV3651 has the ability to receive phone calls and make phone calls when an alarm event is triggered through motion detection or alarm input. Register the GXV3651 to a SIP server to enable the product to make and receive phone calls. To make outgoing phone calls out, the user needs to configure the **Phone List** properly.

Register GXV3651 to a SIP Server

1. From the GXV3651 home page, click **Basic Settings > SIP**.
2. Go to **SIP Settings** Tab.
3. General Phone Settings.

General Phone Settings

Registered: Offline

Unregister On Reboot:

Registered – The field shows the registration status of the account with the SIP server.

Unregister On Reboot – If it's checked, the SIP user's registration information will be cleared from the server when the phone reboots.

4. Enter the required information.

Account Name – The field configures the SIP account name.

SIP Server – The SIP Server's IP address or Domain name provided by your service provider.

Outbound Proxy – The IP address or Domain name of the Outbound Proxy, Media Gateway, or Session Border Controller.

Used for firewall or NAT penetration in different network

environments. If the system detects a symmetric NAT, STUN will not work. ONLY outbound proxies can provide a solution for a symmetric NAT.

SIP User ID – User account information provided by your service provider (ITSP); this is either an actual phone number or is formatted like one.

Authenticate ID – The SIP service subscriber's Authenticate ID used for authentication. It can be identical to or different from the SIP User ID.

Authenticate Password – The SIP service subscriber's account password for the GXV to register to the SIP server of the ITSP.

STUN Server – If the device is behind a router, a STUN server is needed to help penetrate the NAT.

Stream – To choose between Primary and Secondary stream.

Preferred Vocoder – To choose different Vocoder type.

Registration Expiration – This parameter allows users to specify the time frequency (in minutes) in which the GXV refreshes its registration with the specified registrar. The default interval is 60 minutes.

Local SIP Port – This parameter defines the local SIP port used to listen and transmit. The default value is 5060.

Local RTP Port – This parameter defines the local RTP-RTCP port pair that is used to listen and transmit. The default value is 5004.

SIP Settings

Account Name:

SIP Server:

Outbound Proxy:

SIP User ID:

Authenticate ID:

Authenticate Password:

STUN Server:

Stream:

Preferred Vocoder:

Register Expiration(Second):

local SIP Port:

local RTP Port:

Note: You must restart the device to apply the changes.

5. Click **Save** to save all the changes. You need to restart the device to apply all changes.

SIP Open Door Settings

Enable SIP open door – This will close the DO connections in the back to close the circuit connected to it.

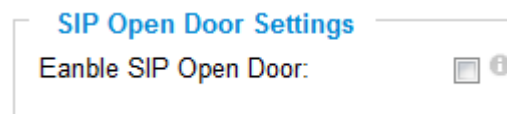

Key to open the door – DTMF key to close the circuit. Digits 0-9 only.

Delay lock time (seconds) – This is the time in seconds that the circuit will remain closed when this function is triggered

Configure *Phone List* Page

To make sure the GXV3651 can make phone calls to the number you preferred when alarm is triggered. You need to add number to the phone list.

Steps to add phone number:

1. From the GXV3651 home page, click **Basic Settings > SIP**.
2. Go to **Phone List** Tab.
3. Enter the **Phone number** and **name**, click **Add a Number** to save all the changes.
4. Numbers added to the system will be listed in this page.

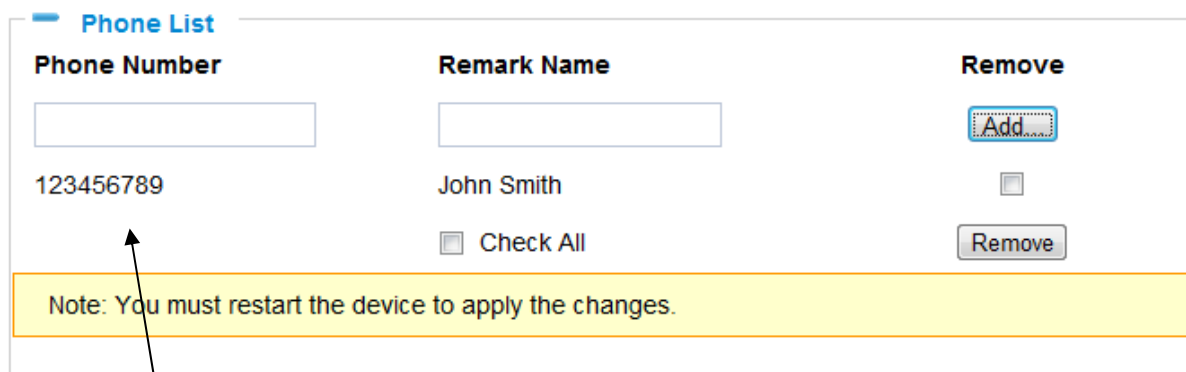

Available phone numbers

NOTE: With current firmware, only the first phone number in the list will be called when an alarm is triggered.

GXV3651 Status Page

System Statistics

System Statistics lists hardware and software information, for example, the part number, the software version, about the GXV3651.

Hardware Version – This field contains the product’s hardware information.

Part Number – This field contains the product part

Firmware 1.0.4.6

Grandstream Networks, Inc. 09/2010

System Statistics	
Product Model:	GXV3601
Hardware Version:	V0.2C
Part Number:	9670000402C
Bootloader Version:	1.0.2.0
Core Version:	1.0.3.2
Base Version:	1.0.4.6
Firmware Version:	1.0.4.6
System Up Time Since:	1 hour 13 minutes

number information.

Bootloader Version – Bootloader code version number.

Core Version – Core code version number.

Base Version – Base code version number.

Firmware Version – Firmware code version number.

System Up Time Since – This field shows the system up time since the last reboot.

Network Status

MAC Address – The device ID, in HEXADECIMAL format.

LAN IP Address – This field shows the LAN IP address of the GXV3651.

LAN Subnet Mask – This field shows the LAN subnet mask of the GXV3651.

LAN Default Gateway – This field shows the LAN default gateway of the GXV3651.

DDNS Status – This field shows the status of DDNS.

Network Status	
MAC Address:	00:0B:82:1F:96:E9
LAN IP Address:	192.168.40.191
LAN Subnet Mask:	255.255.255.0
LAN Default Gateway:	192.168.40.1
DDNS Status:	Disabled
Wifi Status:	Disconnected

Camera Type

This section shows the Lens information of GXV3651. The Lens type information contains the brand name, the size of image sensor, the resolution and so on.

Camera Type	
Camera Type:	Sony 1/3" Super_HAD/NTSC Pixels 510*492

GXV3651 User Management Page

All current users will be list in the User List section of this page. You can also add and remove users here.

Existing User Name –The field lists all of the current users. You can insert or remove users from the list by click on the **Add** or **Update** or **Delete** button.

User Name / Password – The user name and password required to login.

Manage User	
Existing User Name:	--Add New User-- <input type="button" value="v"/>
User Name:	<input type="text"/>
User Password:	<input type="password"/> ⓘ
Confirm User Password:	<input type="password"/>
Privilege:	Administrator <input type="button" value="v"/>
Allow Anonymous Viewing:	<input checked="" type="checkbox"/>
	<input type="button" value="Add"/> <input type="button" value="Update"/> <input type="button" value="Delete"/> <input type="button" value="Save"/>

Privilege – The privilege for the user to access to configuration page.

Allow Anonymous Login – If ‘Allow Anonymous Login’ is set to Yes, no user name and password are required to login to the GXV3651 web configuration pages.

If you login anonymously, you will not be able to change any settings.

GXV3651 Maintenance Page

Server Maintenance

Restart – Click this button to restart the GXV3651.

Restart the device
Restart the device.

Restore – Click this button to perform a partial factory reset (The IP address will not be cleared) .

Restore the device
Reset settings, except IP address, to factory default.

Firmware Upgrade and Provisioning Items

Upgrade via – This field lets you choose the firmware upgrade method. The GXV3651 supports HTTP, HTTPS and TFTP.

Firmware Server Path – The IP address or domain name of the firmware server (the location of the firmware files) .

Automatic Upgrade Interval – Enter the frequency (in minutes) in which the HTTP/HTTPS/TFTP server will be checked for new firmware upgrades or configuration changes.

Automatic Upgrade – The default setting is “No.” Choose “Yes” to enable automatic. HTTP/HTTPS/TFTP upgrade and provisioning. When set to “No”, the IP Camera will only perform a HTTP/HTTPS/TFTP upgrade and perform a configuration check once during the boot process.

Firmware Upgrade and Provisioning	
Upgrade via:	HTTP ▾
Firmware Server Path:	192.168.1.254
Automatic Upgrade Interval(Minutes):	10080
Automatic Upgrade:	<input checked="" type="checkbox"/>

Performing a firmware upgrade:

1. Download the firmware package from <http://www.grandstream.com/firmware.html>.
2. Unzip the firmware package and copy the files to the firmware upgrade server directory.
Upgrades are supported via TFTP, HTTP and HTTPS.
3. Log in to the **Maintenance page** of the GXV3651. Select the server type from the dropdown list under the “Upgrade Via” field. Enter your server’s root directory in the “Firmware Server Path” field.
4. Reboot the GXV3651 to begin the firmware upgrade process.



GXV3651 SMTP Page

The SMTP server is used to send out emails when an alarm event or motion detection is triggered. The SMTP settings must be configured to make sure the alarm email is sent out properly.

SMTP Server Settings

Enable SMTP – Checked to enable SMTP

SMTP Server – The IP or hostname of the SMTP server, for example, smtp.gmail.com.

SMTP Server Port – The port of the SMTP server. The GXV3651 supports port 25 and SSL port 465, which is for SMTP with an encrypted connection.

From E-Mail Address – The email address that sends out the alarm email(s).

To E-Mail Address – The email addresses that the alarm email(s) will be sent to. You can have up to 3 emails configured.

User Name/ Password – The user name and password required to log in to your SMTP server, for example, 123@gmail.com/123.

SSL – Checked if the SMTP server requires a secure connection.

Test Email Account Settings – Click the Test button to send a test email from the *From E-Mail* to the *To E-Mail* to make sure that SMTP is configured properly. If the receiver can get the test email, then the SMTP settings are ready to go.

User List

- admin
- anonymous

SMTP Server Settings

Enable SMTP:

SMTP Server:

SMTP Server Port:

From E-Mail address:

To E-Mail address 1:

To E-Mail address 2:

To E-Mail address 3:

User Name:

Password:

SSL: ⓘ

¹ Required Fields.
² Valid DNS server is required for hostname.

GXV3651 FTP Page

The FTP server is used to store video files if you configure the GXV3651 to record video and upload it to the FTP server when an alarm event or motion detection is triggered.

FTP Settings

Enable FTP – The default setting is “No,” if you want the GXV3651 to upload the recorded video to the FTP server when an alarm is triggered, set this field to “Yes.”

FTP Server – The IP address or hostname of the SMTP server, ie. ftp.myserver.com.

FTP Server Port – The port that your FTP server is using.

User Name / Password – The user name and password required to log into your FTP server

Path – The directory in the FTP server where recorded video will be uploaded.

Test FTP Account Settings – Click the Test button to upload a sample file to make sure that FTP is properly configured.

FTP Settings

Enable FTP:

FTP Server:

FTP Server Port:

User Name:

Password:

Path:

Valid DNS server is required for hostname.

GXV3651 PTZ Page

This page configures the PTZ settings. Select the **PTZ protocol** that your connected equipment supports by clicking on the radio in front of the protocol. Next, select the **Baudrate** from the drop down menu.

PTZ Configuration Items

PTZ Protocol – The GXV3651 supports both Pelco-D and Pelco-P. Select the protocol your PTZ equipment supports.

PTZ Baudrate – The Baud rate is the number of distinct symbol changes (signaling events) made to the transmission medium per second in a digitally modulated signal or a line code.

PTZ Settings

Protocol: Pelco-P Pelco-D

Baudrate: ▼

Connect a PTZ device to the GXV3651

1. Connect the PTZ device to GXV3651 by following the connection diagram shown below

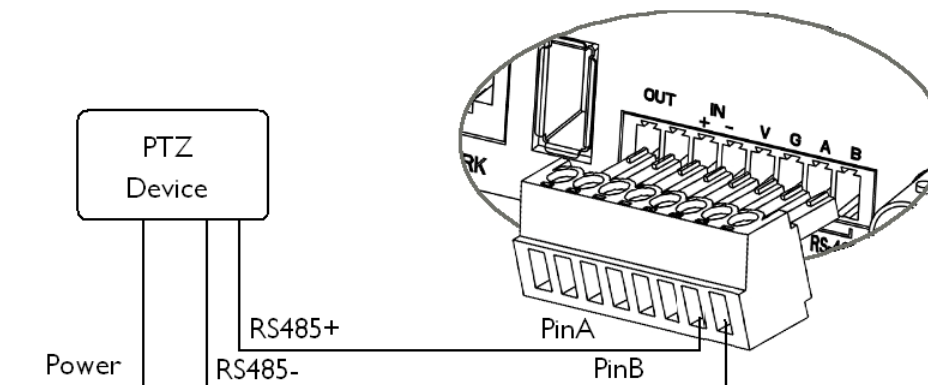

2. Click **Advanced Settings > PTZ**; in **PTZ** page, configure the **PTZ Protocol** and **Baudrate** according to your connected PTZ device.
3. Click **Save** and reboot the device to apply all changes.
4. Use those PTZ buttons on the homepage to tilt, pan the GXV3651 and also adjust the speed.

NOTE: GXV3651 itself does not support PTZ. The users can connect a PTZ device to the GXV3651 via RS485 pins to pan, tilt and speed.

The FOCUS function may not work as many dome cameras support auto focus.

Press and hold the corresponding control button to adjust the pan, tilt, and speed.

GXV3651 Alarm Event

The GXV3651 supports alarm inputs, for example, infrared detector, smoke detector and so on.

Follow the steps to make Alarm Input work:

1. Connect alarm input equipment to the GXV3651.
2. Set up the alarm event time schedule.
3. Configure the alarm actions which you would like the GXV3651 to take when alarm is triggered.

How Alarm Input and Alarm Output Work

Alarm-in is the alarm input port; users are able to connect sensors such as infrared sensor, smoke sensor or light sensor to it. The detectable signal voltage range for alarm-in is from 1.8V to 15 V **NOTE:** Please do not connect a device that has a signal voltage that is higher than 15V, this will damage the IP camera.

Internally, the Alarm-out uses relays as a switch (30VAC/2A); users can connect devices such as alarm siren or alert light to this port. Under normal circumstances, the circuit is open. When there is an alarm event, the GXV3651 will close the circuit to trigger the alarm.

Connect Alarm Input Equipment to the GXV3651

Here are two sample connection diagrams. Connect the alarm equipment to the GXV3651 by following the diagram below.

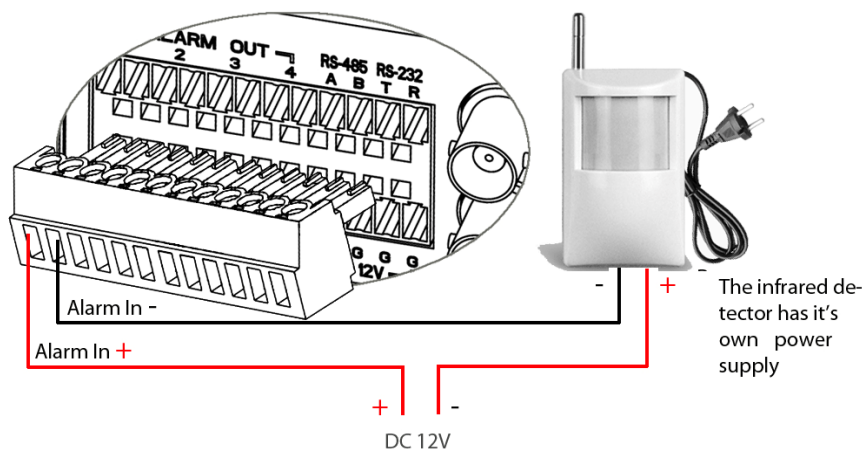
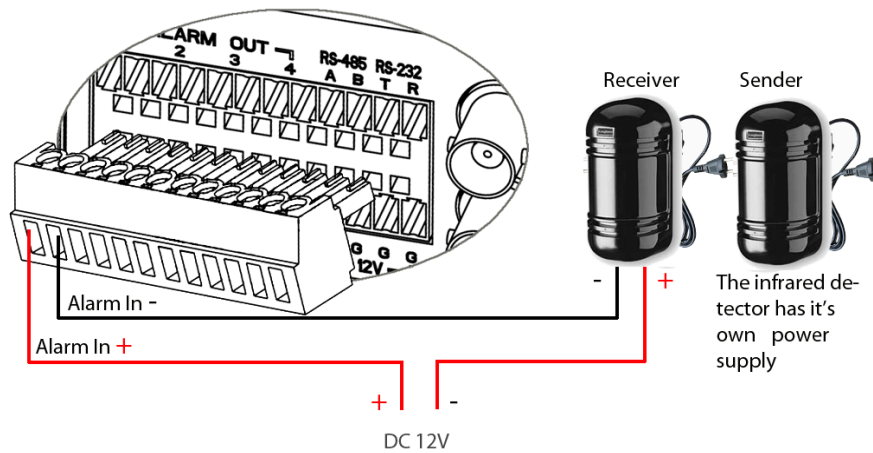

Set up Alarm Actions

An alarm action is what the GXV3651 is going to do when an alarm is triggered during the defined time period – the time schedule. The GXV3651 allows multiple alarm actions.

Record Video – If this option is selected, the GXV3651 will record the video when an alarm is triggered. You can enter the length of the video recording (in seconds). You can also choose the storage method for video files: SD card, USB Flash drive, or USB hard drive.

Alarm Action	
<input type="checkbox"/>	Record Video From Pre Alarm <input type="text" value="0"/> seconds to After Alarm <input type="text" value="10"/> seconds
<input type="checkbox"/>	Voice Alarm to SIP Phone
<input type="checkbox"/>	Alarm Output
<input checked="" type="checkbox"/>	Upload to Alarm Center
<input type="checkbox"/>	Email JPEG and Store it to USB card or SD drive

Voice Alarm to SIP Phone – If this option is selected, the GXV3651 will make calls to the number listed in the **Phone List** page using the configured SIP account when an alarm is triggered. To use this function, the settings in **SIP** page must be configured properly.

Alarm Output – If this option is selected, the alarm will output via the configured method/equipment when it is triggered.

Upload to Alarm Center – This option is an integrated feature with GSurf. If this option is checked, the GXV3651 will report the alarm event to GSurf.

Record Video and Upload to FTP server – If this option is selected, the GXV3651 will record the video and upload it to the FTP server when an alarm is triggered. You must check Record Video and configure the FTP page properly to use this feature.

Email JPEG and Store it to USB drive or SD card – If this option is selected, the GXV3651 will capture the image and store it to connected live storage device when an alarm is triggered.

Set up Alarm Event Time Schedule

This section allows you to configure the time during which the GXV3651 will monitor the Alarm Input. The GXV3651 not only can monitor your settings but also can take actions when the alarm is triggered.

Dropdown list for Available time

Alarm Event Time Schedule

Date	Start Time	End Time	
Tuesday <input type="button" value="v"/>	00:00	23:59	<input type="button" value="Add"/>
Monday	00:00	23:59	<input type="checkbox"/>
Tuesday	00:00	23:59	<input type="checkbox"/>

Check All

To add a schedule, select the **date** from the dropdown list, **Start Time** and **End time** and Click **Add** to add a new time schedule.

To delete a schedule, check the schedule you would like to remove and click **Delete**.

How to connect an Alarm Output Equipment to GXV3651

Here is a sample connection diagram. Connect the alarm output equipment to the GXV3651 by following the diagram below.

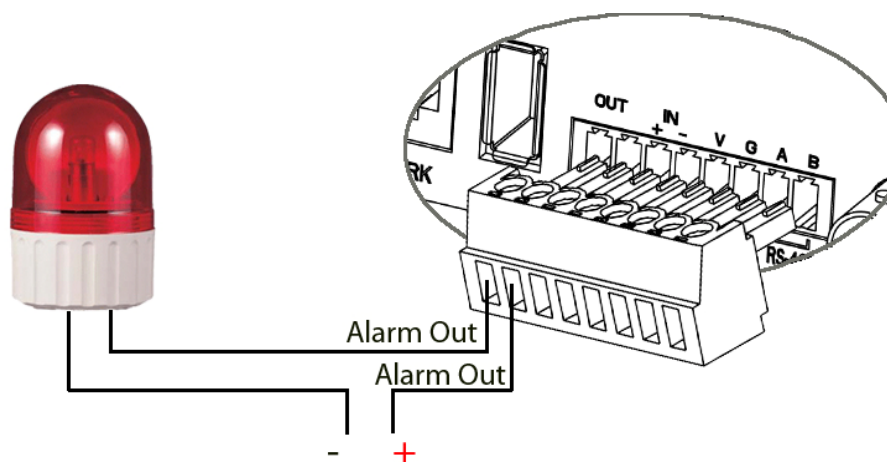

GXV3651 Motion Detection Page

The GXV3651 supports Motion Detection. To utilize this feature, please follow the below steps:

1. Setup the motion detection monitored area.
2. Configure the motion detection time schedule.
3. Configure alarm action properly.

Setup Motion Detection Monitored Area

Enable Motion Detection – If this option is selected, motion detection will be enabled. If something/somebody moves in the motion detection region, an alarm will be triggered.

Show Motion Detection Regions – If this option is selected, the motion detection regions will be displayed on the screen with a white border.



The white border for Motion Detection Regions

NOTE: If *Upload to Alarm center* is checked for *Alarm Actions*, the white border will *flash red* when a motion detection alarm is triggered.

To Edit a Monitored Area

1. In the **Select a Region** dropdown list, select the region ID.
2. Click **Edit**.
3. Click on the video, drag and draw your preferred area.
4. Set the Sensitivity. Click the **Save** button to save the sensitivity.

NOTE: The Sensitivity value varies from 0 to 100. The larger the value is, the higher the sensitivity.

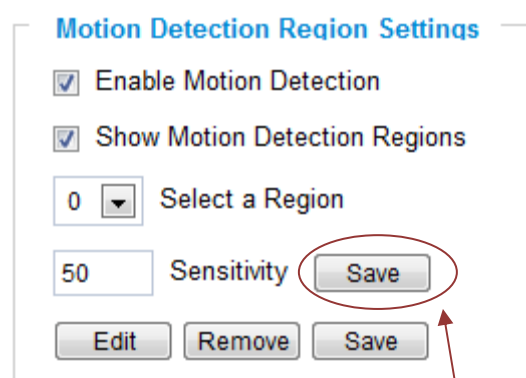

Button to save sensitivity only

5. Click **Save** to save the settings.

To Remove a Monitored Area

1. In the **Select a Region** dropdown list, select the region you would like to remove.
2. Click **Remove**.
3. Click **Save** to save the changes.

Configure Motion Detection & Alarm Actions

An alarm action is what the GXV3651 is going to do when an alarm is triggered during the defined time period – the time schedule. The GXV3651 allows multiple alarm actions.

Alarm Action

Record Video From Pre Alarm seconds to After Alarm seconds

Voice Alarm to SIP Phone

Alarm Output

Upload to Alarm Center

Email JPEG and Store it to USB card or SD drive

Configure Motion Detection Time Schedule

This section allows you to configure the time during which the GXV3651 will monitor the motion detection. The GXV3651 not only can monitor your settings but also can take actions when the alarm is triggered.

Motion Detection Time Schedule

Region ID	Date	Start Time	End Time	
3	Thursday	00:00	23:59	<input type="button" value="Add"/>
0	Monday	00:00	23:59	<input type="checkbox"/>
1	Tuesday	00:00	23:59	<input type="checkbox"/>
3	Thursday	00:00	23:59	<input type="checkbox"/>

Check All

GXV

3651 System Log

This page is used to set up the system log server path and system log level. Once they are correctly configured, the device will send out system log messages to the system log server, which will help perform troubleshooting.

Syslog Server – The IP address or URL of System log server.

Syslog Level – Select the device to report the log level. Default is None. The

SystemLog Settings

Syslog Server:

Syslog Level:

None

None

Debug

Info

Warning

Error

level is one of Debug, Info, Warning or Error.

GXV3651 Live Storage

This page displays detailed information of the live storage devices connected to the GXV3651 such as video and image files. You can view, download or delete the stored files.

Storage Information – This section displays the type, capacity, used space, free space and usage percentage of the connected USB drive or SD card.

Storage Information					
Type	Capacity	Used Space	Free Space	Use(%)	Umount
USB	7.5G	2.3M	7.5G	0.03%	<input type="button" value="Umount"/>

JPEG List – This section displays the name, source storage and size of the image files on the connected storage devices. You can view, download or delete the stored files.

JPEG List			
File Name	Size	View	Check
192.168.40.191_chn1_2010_09_16_07_32_16.jpg	87.1k		<input type="checkbox"/>
Pages:1 Total:1 Index:1-1 Goto: <input type="text" value="1"/> Page		<input type="checkbox"/> Check All	<input type="button" value="Delete"/>

Video List – This section displays the name, source storage and size of the video files on the connected storage devices. You can view, download or delete the stored files.

Video List			
File Name	Size	Download	Check
192.168.40.191_chn1_2010_09_16_07_31_38_1_15.avi	2.1M		<input type="checkbox"/>
Pages:1 Total:1 Index:1-1 Goto: <input type="text" value="1"/> Page		<input type="checkbox"/> Check All	<input type="button" value="Delete"/>

IP VIDEO SURVEILLANCE FAQ

1. What is the default IP address of GXV3651/3501/3504?

Prior to firmware version 1.0.3.9, the IP address of GXV3501/ 3504/ 3601/ 3611 is 192.168.1.168 at the factory default settings. You can perform a factory reset by pressing the RESET button on the device for 7 seconds. Starting from firmware version 1.0.3.9, the default IP configuration is DHCP.

2. Why can I not view the live video stream in Microsoft Internet Explorer?

Please check whether the IE add-on is installed correctly.

Once you log into the GXV3501/ 3504 / 3601's web interface Internet Explorer will indicate that "This website wants to install to following add-on: 'GSViewer. cab' from Grandstream Networks, Inc.". Please install this add-on when prompted by IE.

3. How do you manually uninstall the Grandstream video viewer add-on for IE?

Please follow these steps to uninstall the add-on:

1. Delete the *GSViewerX Control* from *C:\WINDOWS\Downloaded Program Files* directory
2. Delete *GSNetClient.dll*, *GS_Replay.exe*, *GSViewerX.ocx*, *hi_h264dec_w.dll*, *lik_VoiceEngine_dll.dll* and *GSViewerX.inf* from *C:\WINDOWS\system32*

4. Why can't I access the GXV3501/ 3504/ 3601 web configuration interface?

Q 1: Is your internet service down?

A 1: Connect a PC to the internet to test the connection.

Q 2: Are the PC and the device in different subnets?

A 2: Check the subnet mask and default gateway of the device and PC.

Q 3: Is there a conflict with another IP address?

A 3: Try to change the IP address of the device.

Q 4: Has the HTTP port been changed?

A 4: Contact the administrator of the device for more information.

5. The GXV3501/ 3504/ 3601 web configuration page is not displayed correctly in Internet Explorer 8?

In IE8, Compatibility View might need to be enabled for the GXV3501/ 3504/ 3601 web configuration page to load properly. To enable compatibility view, open IE8, click *Tools*, *Compatibility View Setting*, and add the GXV3501/ 3504/ 3601 web configuration pages to the Compatibility View.

6. Why does IE indicate to install Grandstream Video Viewer add-on after a firmware upgrade? The add-on was properly installed before the firmware upgrade process.

New firmware will often upgrade the add-on as well. To watch the live video stream, you must install the newest version of the add-on.

7. How do you watch secondary video stream?

Login to the home page of the GXV3501/ 3504/ 3601 web GUI, click Play to watch the video stream. To watch a secondary video stream, right click on the video, and select *Secondary Stream* on the pop-up menu. Try reinstalling the Grandstream Viewer add-on for IE if you cannot see the video stream.

8. Why is audio missing from the recorded video when an alarm is triggered?

Please double check whether the device has an audio input connected.

The GXV3504 has 4 audio input ports and one MIC IN port. The GXV3501 has a MIC IN port for an audio input. The GXV3651 has a built-in microphone and one MIC IN port for audio inputs.

9. What is DDNS? Is it important for IP surveillance product to have DDNS support?

DDNS is an acronym for Dynamic Domain Name Service. It is important to choose an IP network camera that has DDNS support for dynamic IP addresses.

Chances are that the network has a dynamic IP address (which changes with every log on). A DDNS service makes sure that the camera's IP address always matches up to the current server address. DDNS also allows for a website to be linked to the IP camera that is constantly updated with the correct information and has a reliable feed.

10. Why is Windows Media Player unable to play the recorded videos files?

The GXV3501/3601/3504 all use the H.264 video codec. Windows Media Player may lack the proper H.264 decoder to play the recorded video. Please download the Microsoft FFDSHOW H.264 decoder from <http://sourceforge.net/projects/ffdshow-tryout/> and install it.

11. Alarm Triggered Events do not work in GSurf.

Please double check the Alarm Action on your GXV3501/ 3504/ 3601. Login to the web GUI of the GXV3501/ 3504/ 3601, go to the *Motion Detection* or *Alarm Events* page, and make sure option *Upload to Alarm Center* is checked.

12. It is recommended that you save your video files in different directories when using GSurf and GS_NVR.

GSurf and GS_NVR are different programs that have the ability to delete recorded video files. It is better to save video files in different directories when using GSurf and GS_NVR in the event that they automatically delete files that you might want to keep.

13. How can I use a cell phone to watch the GXV3501/ 3504/ 3601 video stream?

You must set the video resolution to QCIF to watch the GXV3501/3504 /3601 video stream from a cell phone. Make sure to set the bit rate to 64kbps to ensure the best video quality.

14. Why doesn't the IP address of the device reset when I click the "Restore" button on the Maintenance page?

The GXV3501 /3504 /3601 could be installed in areas that are not easy to access. For example, it could be installed on the roof of a building or the ceiling of an office. This makes it difficult to reinstall the device, therefore the "Restore" function will not clear the IP address. Press the RESET button on the device for at least 6 seconds until you hear a beep to perform a factory reset of all parameters (including the IP address).

15. Why can't the live video stream be viewed using a mobile phone or GSurf after

changing the HTTP Port of the device?

Make sure that the RTSP port of the device is set to 2000 plus the HTTP Port number. For example, if the HTTP port is 88, then the RTSP port of the device that you configured on GSurf / mobile phone should be 2088.

16. Some notes on using SD cards / USB drives.

1. The GXV3501/ 3504/ 3601 only supports FAT32 formatted USB drives
2. The GXV3501/ 3504/ 3601 support SD and SDHC
3. It takes 10-15 seconds to read SDHC and USB drives with large memory capacities. Please wait 15 seconds to unplug the SD/USB drive after you plug them into the device.
4. If there are many files (ie. 1800 or more image batch files) on the SD/USB drive, it can take up to 5 minutes to read them. Please do not refresh the web interface at this time as the GXV3501/3504 will restart reading the SD/USB drive. Grandstream is currently working on a fix for this issue.

5. Why is there a black / flashing bar at the bottom of the video feed?

This can occur if the GXV3501 /3504 does not recognize the standard of the connected camera. If you experience this issue, please restart the GXV3501 /3504. The GXV3501 /3504 will detect the standard of the connected camera and use it when the GXV3501 /3504 boots up. To avoid this make sure to connect analog cameras before booting up the GXV3501 /3504.

6. Port forwarding

Two ports must be forwarded on your router to watch video from a GXV3501 /3504 /3601/3611 that is located on a private network from a PC in a public network. The web port (HTTP) and the RTSP port. Please make note that the RTSP port number changes according to the web port. If the web port is 80, then the RTSP port is 554. If the web port is not 80, then the RTSP port equals the web port +2000. For example, if the web port is 88, then the RTSP port will be 2088.

7. Tested PC display adapters.

Display Adapter	Test Result
SiS 650/651/740/661 FX/741/760 Series	Works normally
Intel(R) 82945R Express Chipset Family	Works normally
VIA/S3G UniChrome Pro IGP	Works normally
NVIDIA Geforce 7300GS	Works normally
SiS 661FX	Works normally
SiS Mirage Graphics	Works normally

SiS 661 Series	Works normally
Intel(R) G33/G31 Express	Works normally
SiS Mirage3 Graphics	Works normally
SiS 661FX/GX Mirage Graphics	Works normally
S3 Graphics ProSavageDDR(Microsoft Corporation)	Works normally
XGI Velari Z7/Z9/Z9S V1.08.12	There is some delay when playing videos.
Intel 965 Express Chipset Family	Works normally
ATI Mobility Radeon X1300	Works normally
Intel(R) G45/G43 Express Chipset	Works normally
Mobile Intel 965 Express Chipset Family	Works normally
Mobile Intel(R) 4 Series Express Chipset Family	Works normally
Mobile Intel® 945GM Express Chipset Family	Works normally
Mobile intel® 915GM/GMS, 910GML Express Chipset Family	Works normally
Intel® G45/G43 Express Chipset	Works normally
ATI Technologies, RAGE XL PCI	This display adapter cannot display videos.

FCC Caution

Any Changes or modifications not expressly approved by the party responsible for compliance could void the user's authority to operate the equipment.

This device complies with part 15 of the FCC Rules. Operation is subject to the following two conditions: (1) This device may not cause harmful interference, and (2) this device must accept any interference received, including interference that may cause undesired operation.

This equipment has been tested and found to comply with the limits for a Class B digital device, pursuant to part 15 of the FCC Rules. These limits are designed to provide reasonable protection against harmful interference in a residential installation. This equipment generates uses and can radiate radio frequency energy and, if not installed and used in accordance with the instructions, may cause harmful interference to radio communications. However, there is no guarantee that interference will not occur in a particular installation. If this equipment does cause harmful interference to radio or television reception, which can be determined by turning the equipment off and on, the user is encouraged to try to correct the interference by one or more of the following measures:

- Reorient or relocate the receiving antenna.**
- Increase the separation between the equipment and receiver.**
- Connect the equipment into an outlet on a circuit different from that to which the receiver is connected.**