



Grandstream Networks, Inc.
1297 Beacon Street, 2nd Floor
Brookline, MA 02446. USA
Tel : +1 (617) 566 – 9300
Fax: +1 (617) 249 – 1987

www.grandstream.com

GXP2100 4-Line IP Phone Quick Start Guide

For Warranty and RMA information, please visit www.grandstream.com

The GXP2100 is not pre-configured to support or carry emergency calls to any type of hospital, law enforcement agency, medical care unit (“Emergency Service(s)”) or any other kind of Emergency Service. You must make additional arrangements to access Emergency Services. It is Your responsibility to purchase SIP-compliant Internet telephone service, properly configure the GXP2100 to use that service, and periodically test your configuration to confirm that it works as You expect. If You do not do so, it is Your responsibility to purchase traditional wireless or landline telephone services to access Emergency Services.

GRANDSTREAM DOES NOT PROVIDE CONNECTIONS TO EMERGENCY SERVICES VIA THE GXP2100. NEITHER GRANDSTREAM NOR ITS OFFICERS, EMPLOYEES OR AFFILIATES MAY BE HELD LIABLE FOR ANY CLAIM, DAMAGE, OR LOSS, AND YOU HEREBY WAIVE ANY AND ALL SUCH CLAIMS OR CAUSES OF ACTION ARISING FROM OR RELATING TO YOUR INABILITY TO USE THE GXP2100 TO CONTACT EMERGENCY SERVICES, AND YOUR FAILURE TO MAKE ADDITIONAL ARRANGEMENTS TO ACCESS EMERGENCY SERVICES IN ACCORDANCE WITH THE IMMEDIATELY PRECEDING PARAGRAPH.

PRECAUTIONS:

WARNING: Please DO NOT power cycle the GXP2100 when the LED lights are flashing during system boot up or firmware upgrade. You may corrupt firmware images and cause the unit to malfunction.

WARNING: Use only the power adapter included in the GXP2100 package. Using an alternative non-qualified power adapter may possibly damage the unit.

OVERVIEW

Grandstream GXP2100 is a next-generation enterprise SIP telephone that is feature rich, easy to use, supports Power-over-Ethernet. The GXP2100 features intuitive user interfaces, four (4) individual lines, dual 10/100Mbps Ethernet ports, graphical LCD display and a secure central configuration. This SIP phone combines feature functionality with the latest technology to offer excellent audio quality, ease of use, expandability, and broad interoperability with 3rd party SIP platforms. It is ideal for any business communication environment.

PACKAGE CONTENTS:

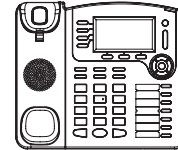

1 X GXP2100 Main Case



1 X Handset

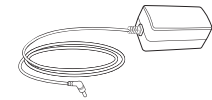

1 X 5V Power adapter

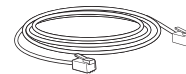

1x Ethernet Cable

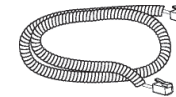

1 X Phone Cord



1 X Quick Install Guide

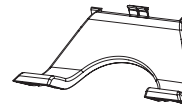

1x Phone Stand

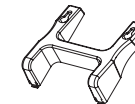

1 X Wall Mount

PHONE SETUP:

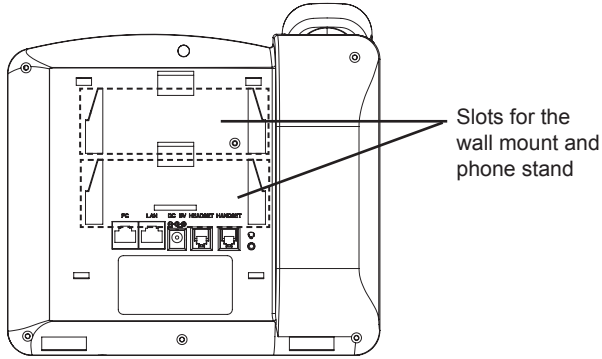

Installing the phone (Wall Mount):

1. Attach the wall mount to the slot on the back of the phone.
2. Attach the phone to the wall via the wall mount hole
3. Pull out the tab on from the handset cradle. (See figure below)
4. Rotate the tab and plug it back into the slot with the extension up to hold the handset while the phone is mounted on the wall. (See figure below)

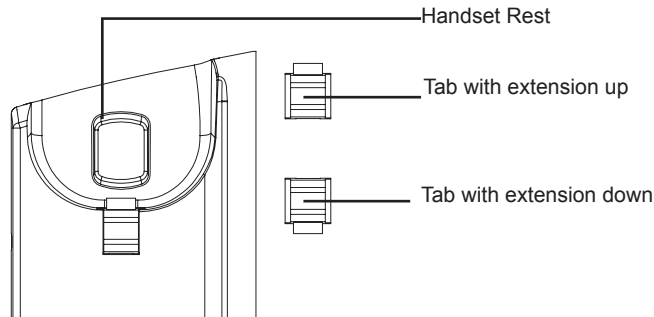

Installing the phone (Phone Stand) :

For installing the phone on the table with the phone stand, attach the phone stand to the bottom of the phone where there is a slot for the phone stand.

CONNECTING THE PHONE:

Refer to the illustration below when following the setup instructions .

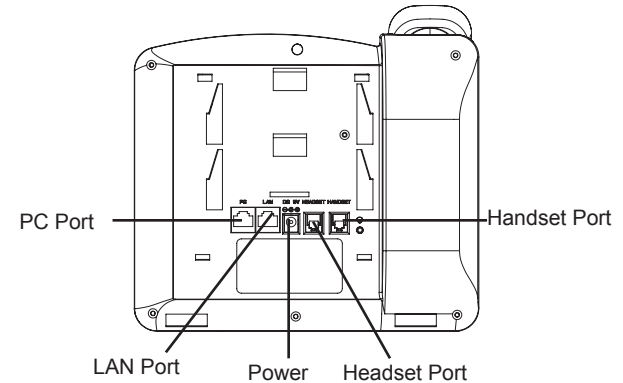

To setup the GXP2100, follow the steps below:

1. Connect the handset and main phone case with the phone cord.
2. Connect the LAN port of the phone to the RJ-45 socket of a hub/switch or a router (LAN side of the router) using the Ethernet cable.
3. Connect the 5V DC output plug to the power jack on the phone; plug the power adapter into an electrical outlet.
4. The LCD will display provisioning or firmware upgrade information. Before continuing, please wait for the date/time display to show up.
5. Using the phone embedded web server or keypad configuration menu, you can further configure the phone using either a static IP or DHCP.

Tips For Using the Keypad:

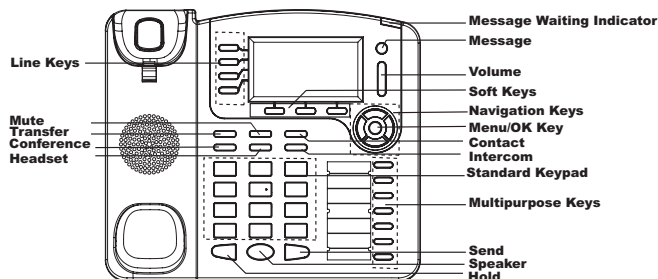

1. To access the MENU, press the round MENU button.
2. Navigate the menu by using the UP/DOWN and LEFT/RIGHT buttons.
3. Press the round MENU button to confirm a menu selection.
4. Delete an entry by pressing the MUTE button.
5. The phone automatically exits MENU mode with an incoming call, the phone goes off-hook or the MENU mode is left idle for 20 seconds.

PHONE CONFIGURATION:

Configure the GXP2100 using a Web Browser:

1. Ensure your phone is powered up and connected to the Internet.
2. Press MENU button to go into menu of the phone.
3. Press the “down” arrow button to “Status” and press MENU button to see the IP address.
4. Type the phone’s IP address in your PC browser. (See figure on right)
5. The default administrator password is “admin”; the default end-user password is “123”.

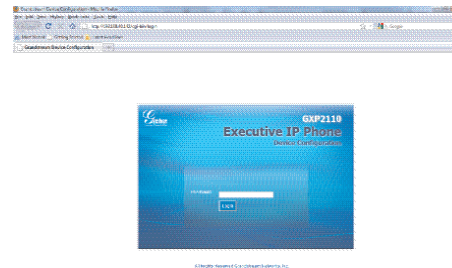

Configure the GXP2100 using the Keypad:

1. Make sure the phone is idle
2. Press the “MENU” button to access the keypad MENU to configure the phone.
3. Select MENU-> Config, to configure settings for SIP Proxy, Outbound Proxy, SIP User ID, SIP Auth ID, SIP Password
4. Follow MENU options to configure the basic features of the phone. For example: the IP address if using a static IP. For details, please check GXP Series User Manual.
5. Please contact your ITSP (Internet Telephony Service Provider) for additional settings that may be necessary to configure the phone.

Note: For the detailed user manual, please download from:
http://www.grandstream.com/support/gxp_series/general/gxp_support.html