



# Grandstream Networks, Inc.

---

HT701

Analog Telephone Adaptor



**TABLE OF CONTENTS**  
HT701 User Manual

<b>WELCOME.....</b>	<b>4</b>
SAFETY COMPLIANCES.....	4
WARRANTY.....	4
<b>CONNECT YOUR HT701 .....</b>	<b>5</b>
EQUIPMENT PACKAGING.....	5
CONNECTING THE HT701.....	5
<b>PRODUCT OVERVIEW .....</b>	<b>8</b>
SOFTWARE FEATURES OVERVIEW .....	8
HARDWARE SPECIFICATION.....	9
<b>BASIC OPERATIONS .....</b>	<b>10</b>
UNDERSTANDING HT701 VOICE PROMPT .....	10
PLACING A PHONE CALL.....	11
CALL HOLD.....	12
CALL WAITING .....	12
CALL TRANSFER .....	12
3-WAY CONFERENCING .....	13
FAX SUPPORT .....	13
<b>CALL FEATURES .....</b>	<b>14</b>
<b>CONFIGURATION GUIDE .....</b>	<b>15</b>
CONFIGURING THE HT701 THROUGH VOICE PROMPTS .....	15
CONFIGURING THE HT701 VIA WEB BROWSER .....	15
IMPORTANT SETTINGS.....	16
Preferred VOCODER (Codec) .....	16
ADVANCED USER CONFIGURATION .....	19
SAVING THE CONFIGURATION CHANGES .....	28
REBOOTING THE HT701 FROM REMOTE.....	28
CONFIGURATION THROUGH A CENTRAL SERVER.....	28
<b>SOFTWARE UPGRADE.....</b>	<b>29</b>
FIRMWARE UPGRADE THROUGH TFTP/HTTP/HTTPS .....	29
CONFIGURATION FILE DOWNLOAD .....	30
FIRMWARE AND CONFIGURATION FILE PREFIX AND POSTFIX .....	30
MANAGING FIRMWARE AND CONFIGURATION FILE DOWNLOAD .....	30
<b>RESTORE FACTORY DEFAULT SETTING.....</b>	<b>31</b>

## TABLE OF FIGURES HT701 USER MANUAL

FIGURE 1: CONNECTING THE HT701 .....	5
FIGURE 2: HT701 CONNECTION DIAGRAM .....	7

## TABLE OF TABLES HT701 USER MANUAL

TABLE 1: DEFINITIONS OF THE HT701 CONNECTORS .....	5
TABLE 2: DEFINITIONS OF THE HT701 LEDs .....	6
TABLE 3: HT701 TECHNICAL SPECIFICATIONS .....	8
TABLE 5: HT701 IVR MENU DEFINITIONS .....	10
TABLE 6: HT701 CALL FEATURES .....	14
TABLE 7: BASIC SETTINGS .....	17
TABLE 8: STATUS PAGE .....	18
TABLE 9: ADVANCED SETTINGS .....	19
TABLE 10: ACCOUNT SETTINGS .....	22

## CONFIGURATION GUI INTERFACE EXAMPLES

### HT701 USER MANUAL

[http://www.grandstream.com/products/ht\\_series/ht701/documents/ht701\\_gui.zip](http://www.grandstream.com/products/ht_series/ht701/documents/ht701_gui.zip)

1. SCREENSHOT OF ADVANCED USER CONFIGURATION PAGE
2. SCREENSHOT OF BASIC SETTINGS CONFIGURATION PAGE
3. SCREENSHOT OF FXS PORT CONFIGURATION
4. SCREENSHOT OF STATUS PAGE
5. SCREENSHOT OF LOGIN PAGE
6. SCREENSHOT OF REBOOT PAGE
7. SCREENSHOT OF REBOOTING PAGE

## WELCOME

Thank you for purchasing Grandstream's HT701, the affordable, feature rich Analog Telephone Adaptor. Grandstream HandyTone 701 is a new addition to the popular HandyTone ATA product family. It features the rich audio quality, a broad range of voice codecs, and functionality of the HT701, including one FXS port with an independent SIP account.

This manual will help you learn how to operate and manage your HandyTone701 Analog Telephone Adaptor and make the best use of its many upgraded features including simple and quick installation, 3-way conferencing, direct IP-IP Calling new provisioning support among other features. This HT701 is very easy to manage and configure, and is specifically designed to be an easy to use and affordable VoIP solution for both the residential user and the teleworker.

## Safety Compliances

The HT701 phone complies with FCC/CE and various safety standards. The HT701 power adaptor is compliant with UL standard. Only use the universal power adapter provided with the HT701 package. The manufacturer's warranty does not cover damages to the phone caused by unsupported power adaptors.

## Warranty

If you purchased your HT701 from a reseller, please contact the company where you purchased your device for replacement, repair or refund. If you purchased the product directly from Grandstream, contact your Grandstream Sales and Service Representative for a RMA (Return Materials Authorization) number before you return the product. Grandstream reserves the right to remedy warranty policy without prior notification.

**Caution:** *Changes or modifications to this product not expressly approved by Grandstream, or operation of this product in any way other than as detailed by this User Manual, could void your manufacturer warranty. Please do not use a different power adaptor with the HT701 as it may cause damage to the products and void the manufacturer warranty.*

- This document contains links to HT701 GUI Interfaces. Please download these examples from [http://www.grandstream.com/products/ht\\_series/ht701/documents/ht701\\_gui.zip](http://www.grandstream.com/products/ht_series/ht701/documents/ht701_gui.zip) for your reference.
- This document is subject to change without notice. The latest electronic version of this user manual is available for download at: [http://www.grandstream.com/products/ht\\_series/ht701/documents/ht701\\_usermanual\\_english.pdf](http://www.grandstream.com/products/ht_series/ht701/documents/ht701_usermanual_english.pdf)

*Reproduction or transmittal of the entire or any part, in any form or by any means, electronic or print, for any purpose is not permitted without the express written permission of Grandstream Networks, Inc.*

## CONNECT YOUR HT701

### Equipment Packaging

The HT701 ATA package contains:

- One HT701 Main Case
- One Universal Power Adaptor
- One Ethernet Cable

### Connecting the HT701

The HT701 is designed for easy configuration and easy installation. Configure the HT701 following the directions in the Configuration section of this manual.

1. Connect a standard touch-tone analog telephone to the PHONE port.
2. Insert a standard RJ11 telephone cable into the Phone1 port and connect the other end of the telephone cable to the analog telephone.
3. Insert the Ethernet cable into the WAN port of HT701 and connect the other end of the Ethernet cable to an uplink port (a router or a modem, etc.)
4. Insert the power adapter into the HT701 and connect it to a wall outlet.

The HT701 Analog Telephone Adaptor is an all-in-one VoIP integrated device designed to be a total solution for networks providing VoIP services. The HT701 VoIP features and functions are available using a regular analog telephone.

**Figure 1: Connecting the HT701**

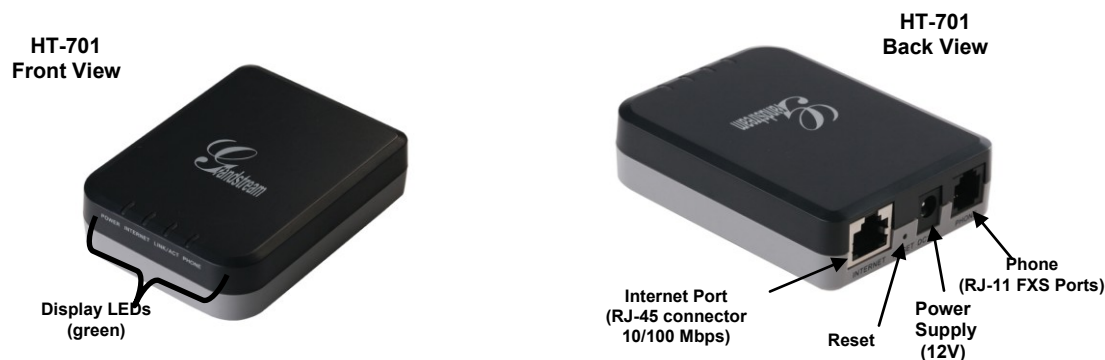

*Table 1: Definitions of the HT701 Connectors*

<b>Power Cable</b>	Power adapter connection
<b>Internet Port (RJ-45)</b>	Connect to the internal LAN network or router.
<b>RESET</b>	Factory Reset button: Press for 7 seconds to reset factory default settings.
<b>FXS Port (RJ-11)</b>	FXS port: to be connected to analog phones / fax machines.

There are four (4) LED buttons that help you manage the status of your HandyTone.

*Table 2: Basic Definitions of the HT701 LEDs Pattern*

LEDs	
<b>POWER LED</b>	Indicates Power. Remains ON when power is connected
<b>Internet LED</b>	Indicates Access to Internet. Remains ON while there is Access
<b>Link/Activity LED</b>	Indicates if There is Activity on the Internet Port
<b>PHONE LED</b>	Indicate status of the respective FXS Ports-PHONE on the back panel Unregistered – OFF Registered and Available – ON (Solid Green) Off-Hook / Busy – Blinking every second Slow blinking FXS LEDs indicates voicemail

**NOTE:** All LEDs display green when ON

*Table 3: Advanced Definitions of the HT701 LEDs Pattern*

Patten Number	Condition	LED	LED Behavior
<b>LED-01</b>	Device has normal power	Power	ON
<b>LED-02</b>	Power Error: Power is removed from the device or power supply with improper voltage is plugged in	Power	OFF
<b>LED-03</b>	Line X is registered normally to the sip providers network and is ready to make a call	Phone	ON
<b>LED-04</b>	Voice mail waiting for Line X	Phone	1sec ON / 3sec OFF
<b>LED-05</b>	Device has normal WAN connection and has obtained IP address	Internet	ON
<b>LED-06</b>	Internet link error: Device is powered up and ready to connect to the Internet but the WAN/INTERNET port is down	Internet	OFF
<b>LED-07</b>	Internet DHCP Error: Device is properly connected but it is unable to retrieve an IP address from the device it is connected to	Internet	0.25sec ON/ 0.25sec OFF
<b>LED-08</b>	Line Registration failed: Device is properly setup, can connect to provider's network, but cannot register to provider's SIP proxy (no 200 OK)	Phone	OFF
<b>LED-09</b>	Device is connected (has physical data link) but there are incorrect network settings typically associated with PPPoE connection failure	Internet	0.25sec ON/ 0.25sec OFF
<b>LED-10</b>	Hazardous potential test failed: Hazardous AC or DC voltage is present on the tip and ring or both signals of phone line X	Phone	0.25sec ON/ 0.25sec OFF
<b>LED-11</b>	Foreign electro Motive Force (EMF) Test fail. Foreign voltage is present on the tip, ring or both signals of phone line. Device has detected additional external Phone voltage on the FXS phone line.	Phone	0.25sec ON/ 0.25sec OFF
<b>LED-12</b>	Resistive fault test failed. Either tip or ring is shorted to ground or they are shorted to each other.	Phone	0.25sec ON/ 0.25sec OFF
<b>LED-13</b>	Receiver off hook test fail. One or more phones are off hook on phone line during test.	Phone	0.25sec ON/ 0.25sec OFF
<b>LED-14</b>	REN test failed – high REN detected. Too many parallel phones connected to phone line X	Phone	0.25sec ON/ 0.25sec OFF
<b>LED-15</b>	Line is active	Phone	1 sec ON/ 1 sec OFF

<b>LED-16</b>	Line inactive	Phone	ON
<b>LED-17</b>	During Provisioning Stage*	Internet / Phone	0.2sec ON/ 0.2sec OFF
<b>LED-18</b>	During Firmware Recovery Stage*	Internet / Phone	0.4sec ON/ 0.4sec OFF

**\*Note:** In Provisioning and Firmware Recovery Stage, the power LED is Steady ON.

**Figure 2: HT701 Connection Diagram**

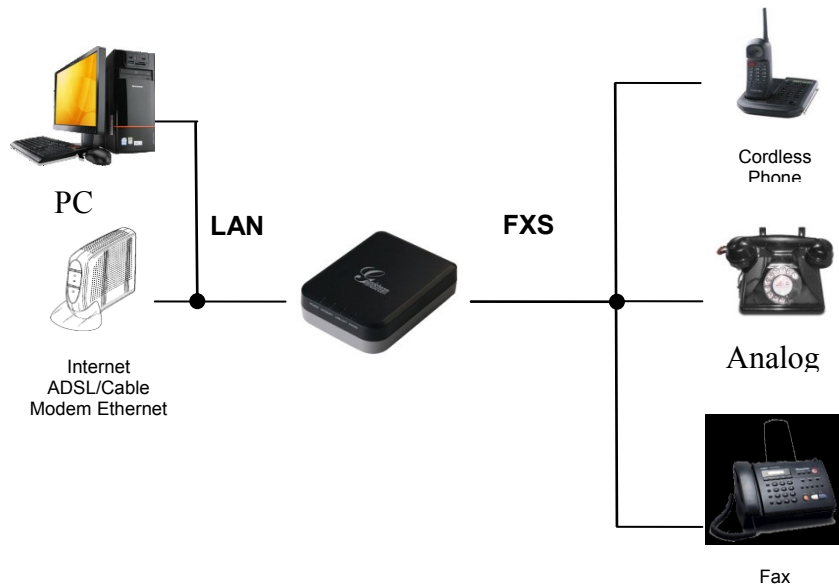

## PRODUCT OVERVIEW

The HT701 is a full feature voice and fax-over IP device that offers a high-level of integration including a 10M/100Mbps network port and one FXS telephone port, market-leading sound quality, rich functionalities, and a compact and lightweight design. The VoIP network signaling protocol supported is SIP. The HT701 fully compatible with SIP industry standard and can interoperate with many other SIP compliant devices and software on the market. Moreover, it supports comprehensive voice codecs including G.711 (a/μ-law), G.723, G.726-32, G.729 and iLBC.

### Software Features Overview

- 1 SIP account & profile
- Supports Voice Codecs:
  - G.711 (a/μ-law), G.723, G.726-32, G.729 and iLBC.
  - T.38 Fax
- Comprehensive Dial Plan support for Outgoing calls.
- G.168 Echo Cancellation
- Voice Activation Detection (VAD), Comfort Noise Generation (CNG), and Packet Loss Concealment (PLC)
- Supports PSTN/PBX analog telephone sets or analog trunks

Table 4: HT701 Technical Specifications

<b>Telephone Interfaces</b>	1 FXS port, 1 SIP account
<b>Network Interface</b>	1 RJ45 for LAN, 10/100 Base-TX, Full Duplex
<b>LED Indicators</b>	Power, INTERNET, LINK/ACTIVITY, PHONE
<b>Reset Button</b>	Factory Reset button
<b>Voice over Packet Capabilities</b>	Voice Activity Detection (VAD) with CNG (comfort noise generation) and PLC (packet loss concealment), Dynamic Jitter Buffer, Modem detection & auto-switch to G.711, Packetized Voice Protocol Unit (supports RTP/RTCP protocol), G.168 compliant Echo Cancellation, LEC (line echo cancellation) with NLP, Asymmetric RTP stream
<b>Voice Compression</b>	G.711 + Annex I (PLC), Annex II (VAD/CNG format) encoder and decoder, G.723, G.726(ADPCM), G.729, iLBC, G.726 provides proprietary VAD, CNG, and signal power estimation, Voice Play Out unit (reordering, fixed and adaptive jitter buffer, clock synchronization), AGC (automatic gain control), Status output, Decoder controlling via voice packet header
<b>Telnet Server</b>	Yes
<b>Fax over IP</b>	T.38 compliant Group 3 Fax Relay up to 14.4kpbs and auto-switch to G.711 for Fax Pass-through, Fax Datapump V.17, V.19, V.27ter, V.29 for T.38 fax relay
<b>QoS</b>	Diffserve, TOS, 802.1 P/Q VLAN tagging
<b>IP Transport</b>	RTP/RTCP
<b>DTMF Method</b>	Flexible DTMF transmission method, user interface of In-audio, RFC2833, and/or SIP Info
<b>IP Signaling</b>	SIP (RFC 3261)
<b>Provisioning</b>	TFTP, HTTP, HTTPS
<b>Control</b>	TLS/SIPS, SIP over TCP/TLS
<b>Device Management</b>	Web interface or via secure encrypted AES or non-encrypted central configuration file for mass deployment using Grandstream binary file or xml format. Auto/manual





	provisioning system or via built-in IVR. NAT-friendly remote software upgrade (via TFTP/HTTP/HTTPS) for deployed devices including behind firewall/NAT. Syslog support. Full support of TR-069 management protocol.
<b>Dial Plan</b>	Yes
<b>Universal Switching Power Adaptor</b>	<i>Input:</i> 100–240 VAC/50-60 Hz 0.18A Max <i>Output:</i> 12VDC, 0.5A, <b>UL</b> certified
<b>Environmental</b>	Operational: 32°–104°F or 0°–40°C Storage: 10°–130° F / Humidity: 10–90% Non-condensing
<b>Dimensions (H x W x D)</b>	86mm (L) x 65mm (W) x 26mm (H)
<b>Short Haul Loop</b>	5REN, Up to 1Km on 24 AWG wire
<b>Call Handling Features</b>	Caller ID display or block, Call waiting caller ID, Call waiting/flash, Call transfer, hold, forward, 3-way conferencing, message waiting, Do-Not-Disturb (DND), call-return service
<b>Caller ID</b>	Bellcore Type 1 & 2, ETSI, BT, NTT, and DTMF-based CID
<b>Polarity Reversal / Wink</b>	Yes
<b>EMC</b>	EN55022/EN55024 and FCC part15 Class B
<b>Safety</b>	UL

## Hardware Specification

The table below lists the hardware specification of HT701.

**TABLE 5: HT701 HARDWARE SPECIFICATION**

<b>LAN Interface</b>	1 RJ45 10/100Mbps
<b>LED</b>	4 LEDs (GREEN)
<b>Universal Switching Power Adaptor</b>	<b>Input:</b> 100-240V AC, 50/60Hz, 0.18A Max <b>Output:</b> 12V DC, 0.5A <b>UL</b> certified
<b>Dimension</b>	86mm (L) x 65mm (W) x 25mm (H)
<b>Weight</b>	31 g (0.07lbs)
<b>Temperature</b>	32~104°F / 0~40°C
<b>Humidity</b>	10% - 90% (non-condensing)
<b>Compliance</b>	  

## BASIC OPERATIONS

### Understanding HT701 Voice Prompt

HT701 has a built-in voice prompt menu for simple device configuration. The IVR menu and the LED button work with any of the FXS port. Pick up the handset and dial “\*\*\*\*” to use the IVR menu.

Table 6: HT701 IVR Menu Definitions

Menu	Voice Prompt	Options
<b>Main Menu</b>	“Enter a Menu Option”	Press “*” for the next menu option Press “#” to return to the main menu Enter 01-05, 07,10, 13-17,47 or 99 menu options
<b>01</b>	“DHCP Mode”, “Static IP Mode”	Press “9” to toggle the selection If using “ <i>Static IP Mode</i> ”, configure the IP address information using menus 02 to 05. If using “ <i>Dynamic IP Mode</i> ”, all IP address information comes from the DHCP server automatically after reboot.
<b>02</b>	“IP Address “ + IP address	The current WAN IP address is announced If using “ <i>Static IP Mode</i> ”, enter 12 digit new IP address. <b>You need to reset the HT to take affect the new IP address.</b>
<b>03</b>	“Subnet “ + IP address	Same as menu 02
<b>04</b>	“Gateway “ + IP address	Same as menu 02
<b>05</b>	“DNS Server “ + IP address	Same as menu 02
<b>07</b>	Preferred Vocoder	Press “9” to move to the next selection in the list: <ul style="list-style-type: none"> <li>• PCM U / PCM A</li> <li>• iLBC</li> <li>• G-726</li> <li>• G-723</li> <li>• G-729</li> </ul>
<b>10</b>	“MAC Address”	Announces the Mac address of the unit.
<b>13</b>	Firmware Server IP Address	Announces current Firmware Server IP address. Enter 12 digit new IP address.
<b>14</b>	Configuration Server IP Address	Announces current Config Server Path IP address. Enter 12 digit new IP address.
<b>15</b>	Upgrade Protocol	Upgrade protocol for firmware and configuration update. Press “9” to toggle between <b>TFTP / HTTP / HTTPS</b>
<b>16</b>	Firmware Version	Firmware version information.
<b>17</b>	Firmware Upgrade	Firmware upgrade mode. Press “9” to toggle among the following three options: <ul style="list-style-type: none"> <li>- always check</li> <li>- check when pre/suffix changes</li> <li>- never upgrade</li> </ul>
<b>47</b>	“Direct IP Calling”	Enter the target IP address to make a direct IP call, after dial tone. (See “ <i>Make a Direct IP Call</i> ”.)
<b>86</b>	Voice Mail	Number of Voice Mails
<b>99</b>	“RESET”	Press “9” to reboot the device Enter MAC address to restore factory default setting (See <b>Restore Factory Default Setting</b> section)
	“Invalid Entry”	Automatically returns to main menu

“Device not registered”

This prompt will be played immediately after off hook If the device is not register and the option “Outgoing Call without Registration” is in NO

### Five Success Tips when using the Voice Prompt

1. “\*” shifts down to the next menu option
2. “#” returns to the main menu
3. “9” functions as the ENTER key in many cases to confirm an option
4. All entered digit sequences have known lengths - 2 digits for menu option and 12 digits for IP address. For IP address, add **0** before the digits if the digits are less than 3 (i.e. - 192.168.0.26 should be key in like 192168**0000**26. No decimal is needed).
5. Key entry can not be deleted but the phone may prompt error once it is detected

## Placing a Phone Call

### Phone or Extension Numbers

1. Dial the number directly and wait for 4 seconds (Default “No Key Entry Timeout”); or
2. Dial the number directly and press # (Use # as dial key” must be configured in web configuration).

### Examples:

1. Dial an extension directly on the same proxy, (e.g. 1008), and then press the # or wait for 4 seconds.
2. Dial an outside number (e.g. (626) 666-7890), first enter the prefix number (usually 1+ or international code) followed by the phone number. Press # or wait for 4 seconds. Check with your VoIP service provider for further details on prefix numbers.

### Direct IP Calls

Direct IP calling allows two parties, that is, a FXS Port with an analog phone and another VoIP Device, to talk to each other in an ad hoc fashion without a SIP proxy.

### Elements necessary to completing a Direct IP Call:

1. Both HT701 and other VoIP Device, have public IP addresses, or
2. Both HT701 and other VoIP Device are on the same LAN using private IP addresses, or
3. Both HT701 and other VoIP Device can be connected through a router using public or private IP addresses (with necessary port forwarding or DMZ).

HT701 supports two ways to make Direct IP Calling:

### Using IVR

1. Pick up the analog phone then access the voice menu prompt by dial “\*\*\*”
2. Dial “**47**” to access the direct IP call menu
3. Enter the IP address after the dial tone and voice prompt “Direct IP Calling”

### Using Star Code

1. Pick up the analog phone then dial “\***47**”
2. Enter the target IP address.

Note: **NO** dial tone will be played between step 1 and 2.

Destination ports can be specified using "\*" (encoding for ".") followed by the port number.

### Examples of Direct IP Calls:

- a) If the target IP address is 192.168.0.160, the dialing convention is **\*47 or Voice Prompt with option 47, then 192\*168\*0\*160.** followed by pressing the "#" key if it is configured as a send key or wait 4 seconds. In this case, the default destination port 5060 is used if no port is specified.
- b) If the target IP address/port is 192.168.1.20:5062, then the dialing convention would be: **\*47 or Voice Prompt with option 47, then 192\*168\*0\*160\*5062** followed by pressing the "#" key if it is configured as a send key or wait for 4 seconds.

**NOTE:** When completing direct IP call, the "Use Random Port" should set to "NO". You cannot make direct IP calls between FXS1 to FXS2 since they are using same IP.

### Call Hold

Place a call on hold by pressing the "flash" button on the analog phone (if the phone has that button). Press the "flash" button again to release the previously held Caller and resume conversation. If no "flash" button is available, use "hook flash" (toggle on-off hook quickly). You may drop a call using hook flash.

### Call Waiting

Call waiting tone (3 short beeps) indicates an incoming call, if the call waiting feature is enabled. Toggle between incoming call and current call by pressing the "flash" button. First call is placed on hold. Press the "flash" button to toggle between two active calls.

### Call Transfer

#### Blind Transfer

Assume that call Caller A and B are in conversation. A wants to *Blind Transfer* B to C:

3. Caller A presses **FLASH** on the analog phone to hear the dial tone.
4. Caller A dials **\*87** then dials caller C's number, and then # (or wait for 4 seconds)
5. Caller A will hear the confirm tone. Then, A can hang up.

**NOTE:** "Enable Call Feature" must be set to "Yes" in web configuration page.

Caller A can place a call on hold and wait for one of three situations:

1. A quick confirmation tone (similar to call waiting tone) followed by a dial-tone. This indicates the transfer is successful (transferee has received a 200 OK from transfer target). At this point, Caller A can either hang up or make another call.
2. A quick busy tone followed by a restored call (on supported platforms only). This means the transferee has received a 4xx response for the INVITE and we will try to recover the call. The busy tone is just to indicate to the transferor that the transfer has failed.
3. Continuous busy tone. The phone has timed out.

**Note:** continuous busy tone does not indicate the transfer has been successful, nor does it indicate the transfer has failed. It often means there was a failure to receive second NOTIFY – check firmware for most recent release.

### Attended Transfer

Assume that Caller A and B are in conversation. Caller A wants to *Attend Transfer* B to C:

1. Caller A presses **FLASH** on the analog phone for dial tone.
2. Caller A then dials Caller C's number followed by # (or wait for 4 seconds).
3. If Caller C answers the call, Caller A and Caller C are in conversation. Then A can hang up to complete transfer.
4. If Caller C does not answer the call, Caller A can press "flash" to resume call with Caller B.

**NOTE:** When Attended Transfer fails and A hangs up, the HT701 will ring back user A to remind A that B is still on the call. A can pick up the phone to resume conversation with B.

### 3-Way Conferencing

The HT701 supports Bellcore style 3-way Conference.

#### Instructions for 3-way conference:

Assume that call party A and B are in conversation. Caller A(HT701) wants to bring third Caller C into conference:

1. A presses FLASH (on the analog phone, or Hook Flash for old model phones) to get a dial tone.
2. A dials C's number then # (or wait for 4 seconds).
3. If C answers the call, then A presses FLASH to bring B, C in the conference.
4. If C does not answer the call, A can press FLASH back to talk to B.
5. If A presses FLASH during conference, C will be dropped out.
6. If A hangs up, the conference will be terminated for all three parties when configuration "Transfer on Conference Hangup" is set to "No". If the configuration is set to "Yes", A will transfer B to C so that B and C can continue the conversation.

### Fax Support

HT701 supports FAX in two modes: 1) T.38 (Fax over IP) and 2) fax pass through. T.38 is the preferred method because it is more reliable and works well in most network conditions. If the service provider supports T.38, please use this method by selecting Fax mode to be T.38 (default). If the service provider does not support T.38, pass-through mode can be used.

## CALL FEATURES

The HT701 supports all the traditional and advanced telephony features.

Table 7: HT701 Call Features

Key	Call Features
*02	<b>Forcing a Codec</b> (per call) *027110 (PCMU), *027111 (PCMA), *02723 (G723), *02729 (G729), *0272616 (G726-r16), *0272624 (G724-r24), *0272632 (G726-r32), *0272640 (G726-r40), *027201 (iLBC)
*03	<b>Disable LEC</b> (pe call) Dial “*03” + ” number “. <b>No</b> dial tone is played in the middle.
*16	<b>Enable SRTP</b>
*17	<b>Disable SRTP</b>
*30	<b>Block Caller ID</b> (for all subsequent calls)
*31	<b>Send Caller ID</b> (for all subsequent calls)
*47	<b>Direct IP Calling.</b> Dial “*47” + “IP address”. <b>No</b> dial tone is played in the middle. Detail see Direct IP Calling section on page 12.
*50	<b>Disable Call Waiting</b> (for all subsequent calls)
*51	<b>Enable Call Waiting</b> (for all subsequent calls)
*67	<b>Block Caller ID</b> (per call). Dial “*67” + ” number “. <b>No</b> dial tone is played in the middle.
*82	<b>Send Caller ID</b> (per call). Dial “*82” + ” number “. <b>No</b> dial tone is played in the middle.
*69	<b>Call Return Service:</b> Dial *69 and the phone will dial the last incoming phone number received.
*70	<b>Disable Call Waiting</b> (per call). Dial “*70” + ” number “. <b>No</b> dial tone is played in the middle.
*71	<b>Enable Call Waiting</b> (per call). Dial “*71” + ” number “. <b>No</b> dial tone is played in the middle.
*72	<b>Unconditional Call Forward:</b> Dial “*72” and then the forwarding number followed by “#”. Wait for dial tone and hang up. (dial tone indicates successful forward)
*73	<b>Cancel Unconditional Call Forward.</b> To cancel “Unconditional Call Forward”, dial “*73”, wait for dial tone, then hang up.
*74	<b>Enable Paging Call:</b> Dial “*74” and then the destination phone number you want to page.
*78	<b>Enable Do Not Disturb (DND):</b> When enabled all incoming calls are rejected.
*79	<b>Disable Do Not Disturb (DND):</b> When disabled, incoming calls are accepted.
*87	<b>Blind Transfer</b>
*90	<b>Busy Call Forward:</b> Dial “*90” and then the forwarding number followed by “#”. Wait for dial tone then hang up.
*91	<b>Cancel Busy Call Forward.</b> To cancel “Busy Call Forward”, dial “*91”, wait for dial tone, then hang up.
*92	<b>Delayed Call Forward.</b> Dial “*92” and then the forwarding number followed by “#”. Wait for dial tone then hang up.
*93	<b>Cancel Delayed Call Forward.</b> To cancel Delayed Call Forward, dial “*93”, wait for dial tone, then hang up.
<b>Flash/Hook</b>	Toggles between active call and incoming call (call waiting tone). If not in conversation, flash/hook will switch to a new channel for a new call.
<b>#</b>	Pressing pound sign will serve as <b>Re-Dial</b> key.

## CONFIGURATION GUIDE

### Configuring the HT701 through Voice Prompts

#### DHCP MODE

Select voice menu option 01 to enable HT701 to use DHCP.

#### STATIC IP MODE

Select voice menu option 01 to enable HT701 to use STATIC IP mode, then use option 02, 03, 04, 05 to set up IP address, Subnet Mask, Gateway and DNS server respectively.

#### FIRMWARE SERVER IP ADDRESS

Select voice menu option 13 to configure the IP address of the firmware server.

#### CONFIGURATION SERVER IP ADDRESS

Select voice menu option 14 to configure the IP address of the configuration server.

#### UPGRADE PROTOCOL

Select voice menu option 15 to choose firmware and configuration upgrade protocol. User can choose between TFTP and HTTP.

#### FIRMWARE UPGRADE MODE

Select voice menu option 17 to choose firmware upgrade mode among the following three options:

1) always check, 2) check when pre/suffix changes, and 3) never upgrade

### Configuring the HT701 Via Web Browser

HT701 has an embedded Web server that will respond to HTTP GET/POST requests. It also has embedded HTML pages that allow users to configure the HT701 through a web browser such as Microsoft's IE, AOL's Netscape or Mozilla Firefox installed on Windows or Unix OS. (Macintosh OS is not included).

#### Access the Web Configuration Menu

1. Find the IP address of the HT701 using voice prompt menu option 02.
2. Open a web browser, type the IP address. You will see the log in page of the device.

#### Note:

- The IVR announces 12 digits IP address, you need to strip out the leading "0" in the IP address. For ex. IP address: 192.168.001.014, you need to type in <http://192.168.1.14> in the web browser.

Once the HTTP request is entered and sent from a web browser, the user will see a log-in screen. There are two default passwords for the login page:

User Level:	Password:	Web pages allowed:
End User Level	123	Only Status and Basic Settings
Administrator Level	admin	Browse all pages

The password is case sensitive with maximum length of 25 characters. The factory default password for End User and administrator is “123” and “admin” respectively. Only an administrator can access the “ADVANCED SETTING”, “FXS PORTS” configuration pages. Please reference the GUI pages using the following link: [http://www.grandstream.com/products/ht\\_series/HT701/documents/HT701\\_gui.zip](http://www.grandstream.com/products/ht_series/HT701/documents/HT701_gui.zip) .

**NOTE:** If you **cannot** log into the configuration page by using the default password, please check with the VoIP service provider. It is most likely the VoIP service provider has provisioned the device and configured for you therefore the password has already been changed.

## Important Settings

The end-user must configure the following settings according to the local environment. **NOTE:** Most settings on the web configuration pages are set to the default values.

## NAT Settings

If you plan to keep the gateway within a *private network* behind a firewall, we recommend using STUN Server. The following three (3) settings are useful in the STUN Server scenario:

1. **STUN Server** (under Advanced Settings webpage)  
Enter a STUN Server IP (or FQDN) that you may have, or look up a free public STUN Server on the internet and enter it on this field. If using Public IP, keep this field blank.
2. **Use Random Ports** (under Advanced Settings webpage)  
This setting depends on your network settings. Generally if you have multiple IP devices under the same network, it should be set to Yes. If using a Public IP address, set this parameter to No.
3. **NAT Traversal** (under the Profile web pages)  
Set this to Yes when gateway is behind firewall on a private network.

## DTMF Methods

DTMF Settings are in FXS portX pages.

- DTMF in-audio
- DTMF via RTP (RFC2833)
- DTMF via SIP INFO

Set priority of DTMF methods according to your preference. This setting should be based on your server DTMF setting.

## PREFERRED VOCODER (CODEC)

The HT701 supports a broad range of voice codecs. Under Profile web pages, choose your preferred order of different codecs:

- PCMU/A (or G711 $\mu$ /a)



- G729 A/B/E
- G723
- G726 (16/24/32/40)
- iLBC
- AAL2 (all G.726)

*Table 8: Basic Settings*

<b>End User Password</b>	Password to access the Web Configuration Menu. This field is case sensitive with a maximum length of 25 characters.
<b>Web Port</b>	By default, HTTP uses port 80. This field is for customizable web port.
<b>Telnet Server</b>	Default is set to YES.
<b>IP Address</b>	There are two modes to operate the HT701: <b>DHCP mode:</b> all the field values for the Static IP mode are not used (even though they are still saved in the Flash memory.) The HT701 acquires its IP address from the first DHCP server it discovers from the LAN it is connected. <i>Using the PPPoE feature:</i> set the PPPoE account settings. The HT701 will establish a PPPoE session if any of the PPPoE fields is set. <b>Static IP mode:</b> configure the IP address, Subnet Mask, Default Router IP address, DNS Server 1 (primary), DNS Server 2 (secondary) fields. These fields are set to zero by default.
<b>DHCP hostname</b>	Default is <b>blank</b> . This option specifies the name of the client. This field is optional but may be required by some Internet Service Providers.
<b>DHCP domain</b>	Default is <b>blank</b> . This option specifies the domain name that client should use when resolving hostnames via the Domain Name System.
<b>DHCP vendor class ID</b>	Default is <b>HT7XX</b> . Used by clients and servers to exchange vendor-specific information..
<b>PPPoE account ID</b>	PPPoE username. Necessary if ISP requires you to use a PPPoE (Point to Point Protocol over Ethernet) connection.
<b>PPPoE password</b>	PPPoE account password.
<b>PPPoE Service Name</b>	Default is <b>blank</b> . This field is optional. If your ISP uses a service name for the PPPoE connection, enter the service name here.
<b>Preferred DNS server</b>	The preferred DNS Server to be used
<b>Time Zone</b>	Controls how the date/time is displayed according to the specified time zone.

<b>Self-Defined Time Zone</b>	<p>The syntax is <b>std offset dst [offset],start[/time],end[/time]</b> Default is set to : <b>MTZ+6MDT+5,M3.2.0,M11.1.0</b></p> <p><b>MTZ+6MDT+5,</b> Time zone with 6 hours offset with 1 hour ahead which is the US central time. It is positive (+) if the local time zone is west of the Prime Meridian and negative (-) if it is east. <b>Prime Meridian (a.k.a: International or Greenwich Meridian)</b></p> <p><b>M3.2.0,M11.1.0</b> The 1<sup>st</sup> number indicates Month: 1,2,3,...,12 (for Jan, Feb, ..., Dec) The 2<sup>nd</sup> number indicates the n<sup>th</sup> iteration of the weekday: (1st Sunday, 3rd Tuesday etc) The 3<sup>rd</sup> number indicates Weekday: 0,1, 2, ...,6(for Sun, Mon, Tue, ..., Sat) Therefore, this example is the DST which starts from the second Sunday of March to the 1st Sunday of November.</p>
<b>Allow DHCP server to set Time Zone</b>	Default No. Let the DHCP server handle the Time Zone
<b>Language</b>	Languages supported with voice prompt and web interface, except Spanish that it is only in IVR.
<b>Reset Type</b>	<p>Gives the user the option to set to default all VoIP related configuration (mainly everything that located on FXS port), all ISP (Internet Service Provider) configuration which may affect the IP address, or both at the same time.</p> <p>Note: After you choose the reset type, you will have to push the reset button for it to take effect.</p>

In addition to the Basic Settings configuration page, end users also have access to the Device Status page.

*Table 9: Status Page*

<b>MAC Address</b>	The device ID, in HEX format. This is very important ID for ISP troubleshooting. LAN Mac address will appear in this place. The LAN MAC address will be used for provisioning and can be found on the label coming with original box and on the label located on the bottom panel of the device.
<b>LAN IP Address</b>	This field shows the LAN IP address of the HT701.
<b>Product Model</b>	This field contains the product model info.
<b>Hardware Version</b>	This field shows the hardware revision of the unit and the part number.
<b>Software Version</b>	<p><b>Program:</b> This is the main software release. <i>This number is always used for firmware upgrade.</i> Current release is 1.0.0.17 Boot and Loader are seldom changed.</p> <p><b>Bootloader:</b> current version is 1.0.0.xx.</p> <p><b>Core:</b> current version 1.0.0.xx</p> <p><b>Base:</b> current version is 1.0.0.xx</p>
<b>Software Status</b>	This field shows the status of the unit and its actual memory.
<b>System Up Time</b>	Shows system up time since the last reboot.
<b>PPPoE Link Up</b>	Indicates whether the PPPoE connection is up if the HT701 is connected to DSL modem.

<b>NAT</b>	This field indicates the type of NAT connection used by the HT701.					
<b>Port Status</b>	Displays relevant information regarding the FXS port.					
	<b>Port</b>	<b>Hook</b>	<b>Registration</b>	<b>DND</b>	<b>Forward</b>	<b>Busy Forward</b>
	<b>FXS</b>	<b>On Hook</b>	<b>Registered</b>	Yes	613	
	<ul style="list-style-type: none"> <li>• FXS port is registered with its SIP Server.</li> <li>• FXS Port user has set Do Not Disturb.</li> <li>• FXS Port user has set his calls to be forwarded unconditionally to ext 613.</li> <li>• FXS Port user has not set Busy or Delay call Forward.</li> </ul>					

## Advanced User Configuration

Log in to the advanced user configuration page the same way as for the basic configuration page. The password is case sensitive and the factory default password for Advanced User is “*admin*”.

Advanced User configuration includes the end user configuration and the advanced configurations including: a) SIP configuration, b) Codec selection, c) NAT Traversal Setting and d) other miscellaneous configuration. HT701 FXS SIP account has its own configuration page.

*Table 10: Advanced Settings*

<b>Admin Password</b>	This contains the password to access the Advanced Web Configuration page. This field is case sensitive. Only the administrator can configure the “Advanced Settings” page. Password field is purposely left blank for security reasons after clicking update and saved. The maximum password length is 25 characters.
<b>Layer 3 QoS</b>	This field defines the layer 3 QoS parameter which can be the value used for IP Precedence or Diff-Serv or MPLS. Default value is <b>48</b> .
<b>Layer 2 QoS</b>	Value used for layer 2 VLAN tag. Default setting is <b>blank</b> .
<b>STUN Server</b>	IP address or Domain name of the STUN server.
<b>Keep-alive interval</b>	This parameter specifies how often the HT701 sends a blank UDP packet to the SIP server in order to keep the “hole” on the NAT open. Default is 20 seconds. Minimum value is 20 seconds.
<b>Use STUN to detect network connectivity</b>	Use STUN keep-alive to detect WAN side network problems. If keep-alive request does not yield any response for configured number of times, the device will restart the TCP/IP stack. If the STUN server does not respond when the device boots up, the feature is disabled.
<b>Firmware Upgrade and Provisioning</b>	Enables HT701 to download firmware or configuration file through either the TFTP, HTTP or HTTPS server.

<b>Via TFTP Server</b>	<p>This is the IP address of the configured TFTP server. If selected and it is non-zero or not blank, the HT701 retrieves the new configuration file or new code image from the specified TFTP server at boot time. After 5 attempts, the system will timeout and will start the boot process using the existing code image in the Flash memory. If a TFTP server is configured and a new code image is retrieved, the new downloaded image is saved into the Flash memory.</p> <p><u>Note:</u> Please do NOT interrupt the TFTP upgrade process (especially the power supply) as this will damage the device. Depending on the local network, this process can take up to 15 or 20 minutes.</p>
<b>Via HTTP / HTTPS Server</b>	<p>The URL for the HTTP/HTTPS server used for firmware upgrade and configuration via HTTP.</p> <p><i>For example,</i> http://provisioning.mycompany.com:6688/Grandstream/1.0.0.67":<b>6688</b>" is the specific TCP port where the HTTP or HTTPS server is listening; it can be omitted if using default port 80.</p> <p><u>Note:</u> If Auto Upgrade is set to No, HT701 will only do HTTP/HTTPS download once at boot up.</p>
<b>Firmware Server Path</b>	IP address or domain name of firmware server.
<b>Config Server Path</b>	IP address or domain name of configuration server.
<b>XML Config File Password</b>	The password used for encrypting the XML configuration file using OpenSSL. This is required for the phone to decrypt the encrypted XML configuration file.
<b>HTTP/HTTPS User Name</b>	The user name needed to authenticate with the HTTP/HTTPS server.
<b>HTTP/HTTPS Password</b>	The password needed to authenticate with the HTTP/HTTPS server.
<b>Firmware File Prefix</b>	Default is <b>blank</b> . If configured, HT701 will request firmware file with the prefix. This setting is useful for ITSPs. End user should keep it blank.
<b>Firmware File Postfix</b>	Default is <b>blank</b> . End user should keep it blank.
<b>Config File Prefix</b>	Default is <b>blank</b> . End user should keep it blank.
<b>Config File Postfix</b>	Default is <b>blank</b> . End user should keep it blank.
<b>Allow DHCP Option 66 to override server</b>	If set to "Yes", configuration and upgrade server information can be obtained using DHCP option 66 from DHCP server located in customer's environment.
<b>Automatic Upgrade</b>	Choose "Yes" to enable automatic upgrade and provisioning. If select "Check every minutes" input the amount of minutes you want it to check for update. If select "Yes, daily at hour" make sure to input the hour of the day you want it to check for update, e.g. for 11 pm type 23. If select "Yes, weekly on day" make sure you input the day of the week (in format 0-6, 0 is Sunday) you want it to check for update. When set to No, HT701 will only do the following option you select; "Always check for New Firmware at Boot up" will check for new firmware every time the device reboots. "Check New Firmware only when F/W pre/suffix changes" will check for updates only when the pre/suffix has been changed.
<b>Firmware Key</b>	Used for firmware encryption. Should be 32 digit in hexadecimal representation. End user should keep it blank.
<b>Authenticate Conf File</b>	If set to Yes, config file is authenticated before acceptance. This protects the configuration from an unauthorized change.

<b>Firmware Key</b>	Used for firmware encryption. Should be 32 digit in hexadecimal representation. End user should keep it blank.
<b>SSL Certificate</b>	The user specify SSL certificate used for SIP over TLS in X.509 format.
<b>SSL Private Key</b>	The user specify SSL private key used for SIP over TLS in X.509 format.
<b>SSL Private Key Password</b>	User specify password to protect the private key above.
<b>ACS URL</b>	User specify the Auto Configuration Server's URL (TR-069 protocol)
<b>ACS Username</b>	User specify the ACS Username
<b>ACS Password</b>	User specify the ACS password
<b>Periodic Inform Enable</b>	Default is No. If set to YES, device will send inform packets to the ACS
<b>Periodic Inform Interval</b>	Frequency that the inform packets will be sent out to the ACS
<b>Connection Request Username</b>	Set a user name for the ACS to connect to this device
<b>Connection Request Password</b>	Set a password for the ACS to connect to this device
<b>System Ring Cadence</b>	Configuration option is set ring cadence on all FXS ports for all incoming calls. (Syntax: c=on1/off1-on2/off2-on3/off3(only 3 cadences maximum)) Default is set to c=2000/4000; (US standards)
<b>Call Progress Tones</b>	<p>Using these settings, users can configure tone frequencies and cadence according to their preference. By default they are set to North American frequencies. Configure these settings with known values to avoid uncomfortable high pitch sounds. ON is the period of ringing ("On time" in 'ms') while OFF is the period of silence. In order to set a continuous tone, OFF should be zero. Otherwise it will ring ON ms and a pause of OFF ms and then repeat the pattern.</p> <p><u>Example configuration for N.A. Dialtone:</u></p> <p><b>f1=350@-13,f2=440@-13,c=0/0;</b></p> <p><b>Syntax: f1=freq@vol, f2=freq@vol, c=on1/off1-on2/off2-on3/off3; [...]</b></p> <p><b>(Note: freq: 0 - 4000Hz; vol: -30 - 0dBm)</b></p>
<b>Lock Keypad Update</b>	Default is <b>No</b> . If set to "Yes", the configuration update via keypad is disabled.
<b>Disable Voice Prompt</b>	Default is <b>No</b> . Disables the voice prompt configuration.
<b>Disable Direct IP Call</b>	Default is <b>No</b> . Disables the Direct IP Call function.
<b>NTP server</b>	URI or IP address of the NTP (Network Time Protocol) server. This parameter synchronizes the date and time.
<b>Allow DHCP option 42 to override NTP serve</b>	Default <b>NO</b> . Enables the DHCP server to handle the NTP Server via Option 42
<b>Syslog Server</b>	The IP address or URL of System log server. This feature is especially useful for the ITSP (Internet Telephone Service Provider)

<b>Syslog Level</b>	<p>Select the HT701 to report the log level. Default is NONE. The level is one of DEBUG, INFO, WARNING or ERROR. Syslog messages are sent based on the following events:</p> <ol style="list-style-type: none"> <li>1. product model/version on boot up (INFO level)</li> <li>2. NAT related info (INFO level)</li> <li>3. sent or received SIP message (DEBUG level)</li> <li>4. SIP message summary (INFO level)</li> <li>5. inbound and outbound calls (INFO level)</li> <li>6. registration status change (INFO level)</li> <li>7. negotiated codec (INFO level)</li> <li>8. Ethernet link up (INFO level)</li> <li>9. SLIC chip exception (WARNING and ERROR levels)</li> <li>10. memory exception (ERROR level)</li> </ol> <p>The Syslog uses USER facility. In addition to standard Syslog payload, it contains the following components:</p> <p>GS_LOG: [device MAC address][error code] error message</p> <p><u>Example:</u> May 19 02:40:38 192.168.1.14 GS_LOG: [00:0b:82:00:a1:be][000] Ethernet link is up</p>
<b>Download Device Configuration</b>	Allows user to download and save a text file containing all the P values of each setting as configured at that point on the unit. (Note: For Security Reasons, all Passwords won't be Downloaded)
<b>Upload Firmware</b>	Allows the user to upgrade the firmware with the single firmware file by browsing it and loading it from your computer (local directory).

*Table 11: Account Settings*

<b>Profile Active</b>	When set to Yes the FXS port is activated.
<b>Primary SIP Server</b>	SIP Server's IP address or Domain name provided by VoIP service provider.
<b>Failover SIP Server</b>	Failover SIP Server's IP address or Domain name in case primary server does not respond.
<b>Prefer Primary SIP Server</b>	Default is no. If set to yes it will register to Primary Server if registration with Failover server expires
<b>Outbound Proxy</b>	IP address or Domain name of Outbound Proxy, or Media Gateway, or Session Border Controller. Used by HT701 for firewall or NAT penetration in different network environments. If symmetric NAT is detected, STUN will not work and ONLY outbound proxy can correct the problem.
<b>SIP transport</b>	User can select UDP or TCP or TLS.
<b>NAT Traversal (STUN)</b>	<p>This parameter defines whether or not the HT701 NAT traversal mechanism is activated. If activated (by choosing "Yes") and a STUN server is also specified, then the HT701 performs according to the STUN client specification. Using this mode, the embedded STUN client will detect if and what type of firewall/NAT. If the detected NAT is a Full Cone, Restricted Cone, or a Port-Restricted Cone, the HT701 will use its mapped public IP address and port in all of its SIP and SDP messages.</p> <p>If the NAT Traversal field is set to "Yes" <i>with no specified STUN server</i>, the HT701 will periodically (every 20 seconds or so) send a blank UDP packet (with no payload data) to the SIP server to keep the "hole" on the NAT open.</p>
<b>SIP User ID</b>	User account information, provided by VoIP service provider (ITSP). Usually in the form of digit similar to phone number or actually a phone number.

<b>Authenticate ID</b>	SIP service subscriber's Authenticate ID used for authentication. Can be identical to or different from SIP User ID.
<b>Authenticate Password</b>	SIP service subscriber's account password.
<b>Name</b>	SIP service subscriber's name for Caller ID display.
<b>DNS Mode</b>	One from the 3 modes are available for "DNS Mode" configuration: -A Record (for resolving IP Address of target according to domain name) -SRV (DNS SRV resource records indicates how to find services for various protocols) -NAPTR/SRV (Naming Authority Pointer according to RFC 2915) One mode can be chosen for the client to look up server. The default value is "A Record"
<b>Tel URI</b>	The default setting is "Disabled". If the phone has an assigned PSTN Number, this field should be set to "User=Phone" then a "User=Phone" parameter will be attached to the "From header" in the SIP request to indicate the E.164 number. If server supports TEL URI format, then this option needs to be selected.
<b>SIP Registration</b>	Controls whether the HT701 needs to send REGISTER messages to the proxy server. The default setting is Yes.
<b>Unregister on Reboot</b>	Default is No. If set to Yes, the SIP user's registration information will be cleared on reboot.
<b>Outgoing Call without Registration</b>	Default is <b>No</b> . If set to "Yes," user can place outgoing calls even when not registered (if allowed by Internet Telephone Service Provider) but is unable to receive incoming calls.
<b>Register Expiration</b>	This parameter allows the user to specify the time frequency (in minutes) the HT701 refreshes its registration with the specified registrar. The default interval is 60 minutes (or 1 hour). The maximum interval is 65535 minutes (about 45 days).
<b>Registration Retry Wait Time</b>	Retry registration if the process failed. Default is 20 seconds.
<b>Local SIP port</b>	Defines the local SIP port the HT701 will listen and transmit. The default value for FXS port is 5060..
<b>Local RTP port</b>	Defines the local RTP-RTCP port pair the HT701 will listen and transmit. It is the base RTP port for channel 0. When configured, <b>channel 0</b> uses this port _value for RTP and the port_value+1 for its RTCP The default value for FXS port is 5004.
<b>Use Random Port</b>	Default is <b>No</b> . This parameter forces the random generation of both the local SIP and RTP ports when set to Yes. This is usually necessary when multiple HT701 are behind the same NAT.
<b>Refer to Use Target Contact</b>	Default is <b>No</b> . If set to YES, then for Attended Transfer, the "Refer-To" header uses the transferred target's Contact header information.
<b>Transfer on Conference Hang up</b>	Default is <b>No</b> . In which case if the conference originator hangs up the conference will be terminated. When option YES is chosen, originator will transfer other parties to each other so that B and C can choose either to continue the conversation or hang up.
<b>Enable Ring-Transfer</b>	Default is <b>No</b> , this will create a Semi-Attendant Transfer. When set to Yes, device can transfer the call upon receiving ring back tone or SIP message 180.
<b>Disable Bellcore Style 3-Way Conference</b>	Default is <b>No</b> . you can make a Conference by pressing 'Flash' key. If set to <b>Yes</b> , you need to dial *23 + second callee number.
<b>Remove OBP from Route Header</b>	Default is <b>No</b> . When option YES is chosen, the Out Bound Proxy will be removed from Route header.

<b>Support SIP Instance ID</b>	Default is <b>Yes</b> . If set to Yes, the contact header in REGISTER request will contain SIP Instance ID as defined in IETF SIP Outbound draft.
<b>Validate incoming SIP message</b>	Default is <b>No</b> . If set to yes all incoming SIP messages will be strictly validated according to RFC rules. If message will not pass validation process, call will be rejected.
<b>Check SIP User ID for incoming INVITE</b>	Default is <b>No</b> . Check the incoming SIP User ID in Request URI. If they don't match, the call will be rejected. If this option is enabled, the device will not be able to make direct IP calls.
<b>Allow Incoming SIP Messages from SIP Proxy Only</b>	Default is <b>No</b> . Check the incoming SIP messages. If they don't come from the SIP proxy, they will be rejected. If this option is enabled, the device will not be able to make direct IP calls.
<b>SIP T1 Timeout</b>	T1 is an estimate of the round-trip time between the client and server transactions. If the network latency is high, select larger value for more reliable usage.
<b>SIP T2 Interval</b>	Maximum retransmission interval for non-INVITE requests and INVITE responses.
<b>DTMF Payload Type</b>	Sets the payload type for DTMF using RFC2833.
<b>Preferred DTMF method</b>	The HT701 supports up to 3 different DTMF methods including in-audio, via RTP (RFC2833) and via Sip Info. The user can configure DTMF method in a priority list.
<b>Disable DTMF Negotiation</b>	Default is No. If set to yes, use above DTMF order without negotiation
<b>DTMF via RFC2833</b>	Send DTMF via RTP (According to RFC 2833).
<b>DTMF via SIP INFO</b>	Send DTMF via SIP INFO message.
<b>Send Flash Event</b>	Default is <b>No</b> . If set to yes, flash will be sent as DTMF event.
<b>Enable Call Features</b>	Default is <b>Yes</b> . (If Yes, call features using star codes will be supported locally)
<b>Offhook Auto-Dial</b>	This parameter allows users to configure a User ID or extension number that is automatically dialed when off-hook. <u>Only the user part</u> of a SIP address needs to be entered here. The HT701 will automatically append the "@" and the host portion of the corresponding SIP address.
<b>Proxy-Require</b>	SIP Extension to notify SIP server that the unit is behind the NAT/Firewall.
<b>Use NAT IP</b>	NAT IP address used in SIP/SDP message. Default is blank.
<b>Distinctive Ring Tone</b>	<p>Custom Ring Tone 1 to 3 with associate Caller ID: when selected, if Caller ID is configured, then the device will ONLY uses this ring tone when the incoming call is from the Caller ID. System Ring Tone is used for all other calls. When selected but no Caller ID is configured, the selected ring tone will be used for <b>all</b> incoming calls. Distinctive ring tones can be configured not only for matching a whole number, but also for matching prefixes. In this case symbol * (star) will be used.</p> <p><b>For example:</b> if configured as *617, Ring Tone 1 will be used in case of call arrived from the area code 617. Any other incoming call will ring using cadence defined in parameter System Ring Cadence located under Advanced Settings Configuration page.</p> <p><b>Note:</b> If server supports Alert-Info header and standard ring tone set (Bellcore) or distinctive ring tone 1-10 is specified, then the ring tone in the Alert-Info header from server will be used. Bellcore rings and tones are independent from custom ring tones. The custom ring tones can also be specified by alert-info header, for example</p> <p>Alert-Info: &lt;http://127.0.0.1&gt;;info=ring5</p>
<b>Disable Call Waiting</b>	Default is <b>No</b> . If set to YES Call Waiting indication information will not be provided to analog phone connected to this FXS port.
<b>Disable Call-Waiting Caller ID</b>	Default is <b>No</b> . If set to YES Call Waiting caller ID will not be provided to analog phone connected to this FXS port.
<b>Disable Call Waiting Tone</b>	Default is <b>No</b> . This is to disable the stutter Call Waiting Tone when a Call Waiting information arrives. The CWCID information will still be displayed.
<b>Disable Receiver Offhook Tone</b>	Default is <b>No</b> . If set to yes, it will disable the warning to alert that the phone has been left off-hook for an extended period of time.



<b>Disable Reminder Ring for On-Hold Call</b>	Default is <b>No</b> . Do not play the reminder ring when this is set to Yes.
<b>Disable Visual MWI</b>	If set to “ <b>Yes</b> ”, the MWI information will not be transferred to the analog phone connected to the FXS port.
<b>Ring Timeout</b>	Incoming call will stop ringing when not picked up given a specific period of time.
<b>Delayed Call Forward Wait Time</b>	Default value is <b>20 seconds</b> . In case this feature activated using * codes (*92 code), the call will be forwarded after this preconfigured amount of time.
<b>No Key Entry Timeout</b>	Default is <b>4 seconds</b> . Dialing process is completed and outgoing call is initiated if no key entry occurs during this preconfigured interval.
<b>Early Dial</b>	<p>Default is <b>No</b>. Use only if proxy supports 484 response. This parameter controls whether the phone will send an early INVITE each time a key is pressed when a user dials a number. If set to “Yes”, an INVITE is sent using the dial-number collected thus far; Otherwise, no INVITE is sent until the “(Re-)Dial” button is pressed or after about 5 seconds have elapsed if the user forgets to press the “Re-Dial” button.</p> <p>The “Yes” option should be used ONLY if there is a SIP proxy configured and the proxy server supports 484 Incomplete Address response. Otherwise, the call will likely be rejected by the proxy (with a 404 Not Found error).</p> <p><i><u>This feature does NOT work with and should NOT be enabled for direct IP-to-IP calling.</u></i></p>
<b>Dial Plan Prefix</b>	Sets the prefix added to each dialed number.
<b>Use # as Dial Key</b>	Allows users to configure the “#” key as the “Send” (or “Dial”) key. If set to “Yes”, “#” will send the number. In this case, this key is essentially equivalent to the “Dial” key. If set to “No”, this “#” key can be included as part of number.

<b>Dial Plan</b>	<p><b>Dial Plan Rules:</b></p> <ol style="list-style-type: none"> <li>Accept Digits: 1,2,3,4,5,6,7,8,9,0 , *, #, A,a,B,b,C,c,D,d</li> <li>Grammar: x - any digit from 0-9; <ul style="list-style-type: none"> <li>xx+ - at least 2 digits number;</li> <li>xx. – at least 2 digit number.</li> <li>^ - exclude;</li> <li>[3-5] - any digit of 3, 4, or 5;</li> <li>[147] - any digit 1, 4, or 7;</li> <li>&lt;2=011&gt; - replace digit 2 with 011 when dialing</li> <li>&lt;=1&gt; - add a leading 1 to all numbers dialed, vice versa will remove a 1 from the number dialed</li> <li>  - or</li> </ul> <ul style="list-style-type: none"> <li><b>Example 1:</b> {[369]11   1617xxxxxx} – Allow 311, 611, 911, and any 11 digit numbers with leading digits 1617</li> <li><b>Example 2:</b> {^1900x+   &lt;=1617&gt;xxxxxx} – Block any number of leading digits 1900 and add prefix 1617 for any dialed 7 digit numbers</li> <li><b>Example 3:</b> {1xxx[2-9]xxxxxx   &lt;2=011&gt;x+} –Allow any combinations of numbers with 11 digits which has a leading digit 1, but 5th digit cannot be 0 or 1. Or any length of numbers with a minimum of 2 digits beginning with 2, with the leading digit replaced with 011.</li> </ul> </li> <li>Default: Outgoing - {x+}</li> </ol> <p>Example of a simple dial plan used in a Home/Office in the US:  <b>{ ^1900x.   &lt;=1617&gt;[2-9]xxxxxx   1[2-9]xx[2-9]xxxxxx   011[2-9]x.   [3469]11 }</b>  <b>Explanation</b> of example rule (reading from left to right): <ul style="list-style-type: none"> <li><b>^1900x.</b> - prevents dialing any number started with 1900</li> <li><b>&lt;=1617&gt;[2-9]xxxxxx</b> - allows dialing to local area code (617) numbers by dialing 7 numbers and 1617 area code will be added automatically</li> <li><b>1[2-9]xx[2-9]xxxxxx</b>  - allows dialing to any US/Canada Number with 11 digits length</li> </ul> </p>
------------------	---

	<ul style="list-style-type: none"> <li>• <b>011[2-9]x.</b> - allows international calls starting with 011</li> <li>• <b>[3469]11</b> - allow dialing special and emergency numbers 311, 411, 611 and 911</li> </ul> <p><b>Note:</b> In some cases user wishes to dial strings such as *123 to activate voice mail or other application provided by service provider. In this case * should be predefined inside dial plan feature and the Dial Plan should be: { *x+ }.</p>
<b>Subscribe for MWI</b>	Default is <b>No</b> . When set to “Yes” a SUBSCRIBE for Message Waiting Indication will be sent periodically.
<b>Send Anonymous</b>	If this parameter is set to “Yes”, the “From” header along with Privacy and P_Asserted_Identity headers in outgoing INVITE message will be set to anonymous, blocking Caller ID.
<b>Anonymous Call Rejection</b>	Default is <b>No</b> . If set to Yes, incoming calls with anonymous Caller ID will be rejected with 486 Busy message.
<b>Special Feature</b>	Default is <b>Standard</b> . Choose the selection to meet some special requirements from Softswitch vendors.
<b>Session Expiration</b>	Grandstream implemented SIP Session Timer. The session timer extension enables SIP sessions to be periodically “refreshed” via a SIP request (UPDATE, or re-INVITE. Once the session interval expires, if there is no refresh via a UPDATE or re-INVITE message, the session will be terminated. Session Expiration is the time (in seconds) at which the session is considered timed out, if no successful session refresh transaction occurs beforehand. The default value is <b>180 seconds</b> .
<b>Min-SE</b>	The minimum session expiration (in seconds). The default value is 90 seconds.
<b>Caller Request Timer</b>	If selecting “Yes” the phone will use session timer when it makes outbound calls if remote party supports session timer.
<b>Callee Request Timer</b>	If selecting “Yes” the phone will use session timer when it receives inbound calls with session timer request.
<b>Force Timer</b>	If selecting “Yes” the phone will use session timer even if the remote party does not support this feature. Selecting “No” will allow the phone to enable session timer only when the remote party support this feature. To turn off Session Timer, select “No” for Caller Request Timer, Callee Request Timer, and Force Timer.
<b>UAC Specify Refresher</b>	As a Caller, select UAC to use the phone as the refresher, or UAS to use the Callee or proxy server as the refresher.
<b>UAS Specify Refresher</b>	As a Callee, select UAC to use caller or proxy server as the refresher, or UAS to use the phone as the refresher.
<b>Force INVITE</b>	Session Timer can be refreshed using INVITE method or UPDATE method. Select “Yes” to use INVITE method to refresh the session timer.
<b>Send Re-INVITE After Fax</b>	Default is <b>No</b> , If set to “Yes”, device will send an INVITE with audio vocoders upon completion of Fax to continue session in audio only.
<b>Enable Silence Detection for Fax Disconnect</b>	For fax machines that do not send a Disconnect when fax is done. This option Enables/Disables the detection of silence in order to know the fax has finished. The silence period is non-configurable and fixed to 7 seconds.
<b>Enable 100rel</b>	Default is <b>No</b> , If set to Yes, Enables the use of PRACK (Provisional Acknowledgment) method.
<b>Use First Matching Vocoder in 200OK SDP</b>	Default is <b>No</b> . If set to “Yes”, device will include only the first match vocoder in its 200OK response, otherwise it will include all match vocoders in same order received in INVITE.
<b>Preferred Vocoder</b>	The HT701 supports up to 5 different Vocoder types including G.711 A-/U-law, G.726 (Supports bit rates 16, 24, 32 and 40), G.723.1, G.729A/B/E, iLBC and AAL2. The user can configure Vocoders in a preference list that will be included with the same preference order in SDP message. The first Vocoder is entered by choosing the appropriate option in “Choice 1”. The last Vocoder is entered by choosing the appropriate option in “Choice 8”. Vocoder types can also be changed per call basis by using a star code. Please see the “Call features” section.

<b>G723 Rate</b>	Default is <b>6.3kbps</b> . Defines the encoding rate for G.723 vocoder.
<b>iLBC Frame Size</b>	Sets the iLBC frame size in 20ms or 30ms
<b>iLBC Payload type</b>	Defines payload type for iLBC. Default value is 97. The valid range is between 96 and 127.
<b>VAD</b>	Default is <b>No</b> . VAD allows detecting the absence of audio and conserve bandwidth by preventing the transmission of "silent packets" over the network.
<b>Symmetric RTP</b>	Default is <b>No</b> . When set to Yes the device will change the destination to send RTP packets to the source IP address and port of the inbound RTP packet last received by the device.
<b>Fax Mode</b>	T.38 (Auto Detect) FoIP by default, or Pass-Through (must use codec PCMU/PCMA)
<b>Re-Invite after Fax Tone Detection Mode</b>	Default is <b>Enabled</b> . It makes the unit send out the re-INVITE for T.38 or Fax Pass Through if a fax tone is detected.
<b>Jitter Buffer Type</b>	Select either Fixed or Adaptive based on network conditions.
<b>Jitter Buffer Length</b>	Select Low, Medium or High based on network conditions. <ul style="list-style-type: none"> <li>• High (initial 200ms, min 40ms, max 600ms) Note: not all vocoders can meet the high requirement</li> <li>• Medium (initial 100ms, min 20ms, max 200ms)</li> <li>• Low (initial 50ms, min 10ms, max 100ms)</li> </ul>
<b>SRTP Mode</b>	This option defines different implementation of support SRTP (squared RTP) transmission mode.
<b>SLIC Setting</b>	Dependent on standard phone type (and location)
<b>Caller ID Scheme</b>	Bellcore/Telcordia, ETSI-FSK, ETSI-DTMF, SIN 227 – BT, & NTT Japan
<b>Polarity Reversal</b>	Default is <b>No</b> . If set to "Yes", polarity will be reversed upon call establishment and termination.
<b>Loop Current Disconnect</b>	Default is <b>No</b> . Set it to Yes if the traditional PBX you are using with HT701 uses this method for signaling call termination. Method initiates short voltage drop on the line when remote (VoIP) side disconnects an active call.

<b>Loop Current Disconnect Duration</b>	Here can be configured duration of such voltage drop described in topic above.
<b>Hook Flash Timing</b>	Time period when the cradle is pressed (Hook Flash) to simulate FLASH. To prevent unwanted activation of the Flash/Hold and automatic phone ring-back, adjust this time value.
<b>On Hook Timing</b>	On-hook timing is the minimum time for an on-hook event to be validated.
<b>Gain</b>	Voice path volume adjustment. <ul style="list-style-type: none"> <li>• Rx is a gain level for signals <u>transmitted</u> by FXS</li> <li>• Tx is a gain level for signals <u>received</u> by FXS.</li> </ul> <p>Default = <b>0dB</b> for both parameters. Loudest volume: +6dB Lowest volume: -6dB.</p> <p>User can adjust volume of call on either end using the Rx Gain Level parameter and the Tx Gain Level parameter located on the FXS Port Configuration page.</p> <p>If call volume is too low when using the FXS port (ie. the ATA is at user site), adjust volume using the <u>Rx Gain Level</u> parameter under the FXS Port Configuration page.</p> <p>If voice volume is too low at the other end, user may increase the far end volume using the <u>Tx Gain Level</u> parameter under the FXS Port Configuration page.</p>
<b>Disable Line Echo Canceller (LEC)</b>	Default is <b>No</b> . If set to "Yes" LEC will be disabled per call base. Recommended for FAX/Data calls.
<b>Ring Tones</b>	This function lets you configure ring tone cadence preferences. User has 10 choices.

---

The configuration, completed in Distinctive Ring Tones block in the same page, applies to ring tones cadences configured here.

## Saving the Configuration Changes

Click the “Update” button in the Configuration page to save the changes to the HT701 configuration. The following screen confirms that the changes are saved. Reboot or power cycle the HT701 to make the changes take effect.

## Rebooting the HT701 from Remote

Press the “Reboot” button at the bottom of the configuration menu to reboot the ATA remotely. The web browser will then display a message window to confirm that reboot is underway. Wait 30 seconds to log in again.

## Configuration through a Central Server

Grandstream HT701 can be automatically configured from a central provisioning system.

When HT701 boots up, it will send TFTP or HTTP/HTTPS request to download configuration file, “cfg000b82xxxxx” or “cfg00082xxxxx.xml”, where “000b82xxxxx” is the LAN MAC address of the HT701. It will first request “cfg000b82xxxxx” then “cfg000b82xxxxx.xml”

The configuration file can be downloaded via TFTP or HTTP/HTTPS from the central server. A service provider or an enterprise with large deployment of HT701 can easily manage the configuration and service provisioning of individual devices remotely from a central server.

Grandstream has a provisioning system called GAPS (Grandstream Automated Provisioning System) that is used to support automated configuration of Grandstream devices. GAPS uses enhanced (NAT friendly) TFTP or HTTP (thus no NAT issues) and other communication protocols to communicate with each individual Grandstream device for firmware upgrade, remote reboot, etc.

Grandstream provides GAPS service to VoIP service providers. Use GAPS for either simple redirection or with certain special provisioning settings. At boot-up, Grandstream devices by default point to Grandstream provisioning server GAPS, based on the unique MAC address of each device, GAPS provision the devices with redirection settings so that they will be redirected to customer’s TFTP or HTTP/HTTPS server for further provisioning. Grandstream also provide GAPSLITE software package which contains our NAT friendly TFTP server and a configuration tool to facilitate the task of generating device configuration files.

The GAPSLITE configuration tool is now free to end users. The tool and configuration template are available for download from <http://www.grandstream.com/support/tools> .

## SOFTWARE UPGRADE

Software upgrade can be done via either TFTP or HTTP. The corresponding configuration settings are in the ADVANCED SETTINGS configuration page.

### Firmware Upgrade through TFTP/HTTP/HTTPS

To upgrade via TFTP or HTTP/HTTPS, the “Firmware Upgrade and Provisioning upgrade via” field needs to be set to TFTP HTTP or HTTPS, respectively. “Firmware Server Path” needs to be set to a valid URL of a TFTP or HTTP server, server name can be in either FQDN or IP address format. Here are examples of some valid URL.

e.g. `firmware.mycompany.com:6688/Grandstream/1.0.0.17`

e.g. `72.172.83.110`

#### NOTES:

- Firmware upgrade server in IP address format can be configured via IVR. Please refer to the CONFIGURATION GUIDE section for instructions. If the server is in FQDN format, it must be set via the web configuration interface.
- Grandstream recommends end-user use the Grandstream HTTP server. Its address can be found at <http://www.grandstream.com/support/firmware> . Currently the HTTP firmware server IP address is 72.172.83.110. For large companies, we recommend to maintain their own TFTP/ HTTP/HTTPS server for upgrade and provisioning procedures.
- Once a “Firmware Server Path” is set, user needs to update the settings and reboot the device. If the configured firmware server is found and a new code image is available, the HT701 will attempt to retrieve the new image files by downloading them into the GXW400x 's SRAM. During this stage, the HT701's LEDs will blink until the checking/downloading process is completed. Upon verification of checksum, the new code image will then be saved into the Flash. If TFTP/HTTP/HTTPS fails for any reason (e.g. TFTP/HTTP/HTTPS server is not responding, there are no code image files available for upgrade, or checksum test fails, etc), the HT701 will stop the TFTP/HTTP/HTTPS process and simply boot using the existing code image in the flash.
- Firmware upgrade may take as long as 15 to 30 minutes over Internet, or just 5 minutes if it is performed on a LAN. It is recommended to conduct firmware upgrade in a controlled LAN environment if possible. For users who do not have a local firmware upgrade server, Grandstream provides a NAT-friendly TFTP server on the public Internet for firmware upgrade.
- Grandstream's latest firmware is available at <http://www.grandstream.com/support/firmware> .  
*Oversea users are strongly recommended to download the binary files and upgrade firmware locally in a controlled LAN environment.*
- Alternatively, user can download a free TFTP or HTTP server and conduct local firmware upgrade. A free windows version TFTP server is available for download from <http://support.solarwinds.net/updates/New-customerFree.cfm>. Our latest official release can be downloaded from <http://www.grandstream.com/y-firmware.htm>.

#### Instructions for local firmware upgrade:

1. Unzip the file and put all of them under the root directory of the TFTP server.
2. Put the PC running the TFTP server and the HT701 device in the same LAN segment.

3. Please go to File -> Configure -> Security to change the TFTP server's default setting from "Receive Only" to "Transmit Only" for the firmware upgrade.
4. Start the TFTP server, in the phone's web configuration page
5. Configure the Firmware Server Path with the IP address of the PC
6. Update the change and reboot the unit

End users can also choose to download the free HTTP server from <http://httpd.apache.org/> or use Microsoft IIS web server.

## Configuration File Download

Grandstream SIP Device can be configured via Web Interface as well as via Configuration File through TFTP or HTTP/HTTPS. "Config Server Path" is the TFTP or HTTP/HTTPS server path for configuration file. It needs to be set to a valid URL, either in FQDN or IP address format. The "Config Server Path" can be same or different from the "Firmware Server Path".

A configuration parameter is associated with each particular field in the web configuration page. A parameter consists of a Capital letter P and 1 to 3 (Could be extended to 4 in the future) digit numeric numbers. i.e., P2 is associated with "Admin Password" in the ADVANCED SETTINGS page. For a detailed parameter list, please refer to the corresponding firmware release configuration template.

When Grandstream Device boots up or reboots, it will issue request for configuration file named "cfgxxxxxxxxxxx", where "xxxxxxxxxxx" is the LAN MAC address of the device, i.e., "cfg000b820102ab". The configuration file name should be in lower cases.

## Firmware and Configuration File Prefix and Postfix

Firmware Prefix and Postfix allows device to download the firmware name with the matching Prefix and Postfix. This makes it the possible to store ALL of the firmware with different version in one single directory. Similarly, Config File Prefix and Postfix allows device to download the configuration file with the matching Prefix and Postfix. Thus multiple configuration files for the same device can be stored in one directory.

In addition, when the field "Check New Firmware only when F/W pre/suffix changes" is set to "Yes", the device will only issue firmware upgrade request if there are changes in the firmware Prefix or Postfix.

## Managing Firmware and Configuration File Download

When "Automatic Upgrade" is set "**Yes, every**" the auto check will be done in the minute specified in this field. If set to "**daily at hour (0-23)**", Service Provider can use P193 (Auto Check Interval) to have the devices do a daily check at the hour set in this field with either Firmware Server or Config Server. If set to "**weekly on day (0-6)**" the auto check will be done in the day specified in this field. This allows the device periodically check if there are any new changes need to be taken on a scheduled time. By defining different intervals in P193 for different devices, Server Provider can spread the Firmware or Configuration File download in minutes to reduce the Firmware or Provisioning Server load at any given time.

Automatic Upgrade:

- No  Yes, every  minutes(60-5256000).
- Yes, daily at hour  (0-23).  Yes, weekly on day  (0-6).

## RESTORE FACTORY DEFAULT SETTING

**WARNING!** Restoring the Factory Default Setting will DELETE all configuration information of the phone. Please BACKUP or PRINT out all the settings before you approach to following steps. Grandstream will not take any responsibility if you lose all the parameters of setting and cannot connect to your VoIP service provider.

### FACTORY RESET

There are two (2) methods for resetting your unit:

#### Reset Button

Reset default factory settings following these four (4) steps:

1. Unplug the Ethernet cable.
2. Locate a needle-sized hole on the back panel of the gateway unit next to the power connection.
3. Insert a pin in this hole, and press for about 7 seconds.
4. Take out the pin. All unit settings are restored to factory settings.

#### IVR Command

Reset default factory settings using the IVR Prompt (Table 5):

1. Dial “\*\*\*” for voice prompt.
2. Enter “99” and wait for “reset” voice prompt.
3. Enter the encoded MAC address (Look below on how to encode MAC address).
4. Wait 15 seconds and device will automatically reboot and restore factory settings.

#### Encode the MAC Address

1. Locate the MAC address of the device. It is the 12 digit HEX number on the bottom of the unit.
2. Key in the MAC address. Use the following mapping:
  - 0-9: 0-9
  - A: 22 (press the “2” key twice, “A” will show on the LCD)
  - B: 222
  - C: 2222
  - D: 33 (press the “3” key twice, “D” will show on the LCD)
  - E: 333
  - F: 3333

*For example:* if the MAC address is 000**b**8200**e**395, it should be keyed in as “000**222**8200**333**395”.

#### NOTE:

1. Factory Reset will be disabled if the “**Lock keypad update**” is set to “Yes”.
2. Please be aware by default the HT701 WAN side HTTP access is disabled. After a factory reset, the device’s web configuration page can be accessed only from its LAN port.
3. If the HT701 was previously locked by your local service provider, pressing the RESET button will only restart the unit. The device will not return to factory default settings.

## **FCC Caution:**

Any Changes or modifications not expressly approved by the party responsible for compliance could void the user's authority to operate the equipment.

This device complies with part 15 of the FCC Rules. Operation is subject to the following two conditions: (1) This device may not cause harmful interference, and (2) this device must accept any interference received, including interference that may cause undesired operation.

Note: This equipment has been tested and found to comply with the limits for a Class B digital device, pursuant to part 15 of the FCC Rules. These limits are designed to provide reasonable protection against harmful interference in a residential installation. This equipment generates, uses and can radiate radio frequency energy and, if not installed and used in accordance with the instructions, may cause harmful interference to radio communications. However, there is no guarantee that interference will not occur in a particular installation. If this equipment does cause harmful interference to radio or television reception, which can be determined by turning the equipment off and on, the user is encouraged to try to correct the interference by one or more of the following measures:

- Reorient or relocate the receiving antenna.
- Increase the separation between the equipment and receiver.
- Connect the equipment into an outlet on a circuit different from that to which the receiver is connected.
- Consult the dealer or an experienced radio/TV technician for help.