

Graupner HoTT
HOPPING TELEMETRY TRANSMISSION

COMPUTER-SYSTEM

mx-16 HoTT



Programming Manual

Contents

General Information	
Safety Notes	3
Safety notes and handling instructions relating to Nickel-Metal-Hydride rechargeable batteries	8
Foreword.....	10
Description of radio control set.....	11
Recommended battery chargers	13
Transmitter power supply.....	14
Receiver power supply	16
Environmental protection notes	16
Adjusting the stick length.....	17
Opening the transmitter case	17
Changing the stick mode	18
Description of transmitter.....	20
Transmitter controls	20
Rear of transmitter.....	21
Headphone socket	21
Mini-USB socket.....	21
Data socket	21
DSC (Direct Servo Control).....	22
Data storage / card slot	22
Screen and keypad	24
Operating the “Data Terminal”	25
Short-cuts.....	25
Language selection, screen contrast.....	26
On-screen warnings	28
On-screen function fields.....	28
Position indicator, rotary controls CTRL 7 + 8.....	29
Input lock	29
Using the transmitter for the first time.....	30
Using the receiver for the first time	32
Installation notes.....	34
Receiving system power supply.....	35
Definition of terms	38

Switch and transmitter control assignment.....	39
Digital trims.....	40
Fixed-wing model aircraft.....	42
Receiver socket sequence	43/44
Model helicopters	46
Receiver socket sequence	47
Program descriptions	
Setting up a new model memory.....	48
“Model memories”	52
“Base settings” (model)	
Fixed-wing model aircraft	56
Binding receivers.....	61
Range-checking	62
Model helicopter	64
Binding receivers.....	70
Range-checking	70
“Servo settings”.....	72
“Transmitter control settings”	
Fixed-wing model aircraft	74
Model helicopter	76
Throttle limit function.....	79
Basic idle setting	79
“D/R Expo”	
Fixed-wing model aircraft	82
Model helicopter	84
“Phase trim” (fixed-wing)	86
What is a mixer?	88
“Wing mixer”	88
“Heli mixer”	94
Setting up throttle and collective pitch curves	100
Auto-rotation setting	104
General notes re. freely programmable mixers.....	106

“Free mixers”	107
Examples.....	111
“Swashplate mixers”	112
“Servo display”	113
“Basic settings”	114
“Fail-Safe”	116
“Telemetry”	117
Setting & Data view	118
Satellite operation with two receivers	126
Simple data view	127
RF status view.....	129
Voice trigger	130
“Trainer mode”	132
Wiring diagrams	135
Wireless HoTT system	136
“Info”	140
Programming examples	
Introduction.....	142
Fixed-wing model aircraft	
First steps.....	144
Including an electric power system	148
E-motor and Butterfly (crow) using Ch1 stick	150
Operating timers.....	153
Use of flight phases.....	154
Servos running in parallel.....	155
Deltas and flying wings.....	156
F3A models	160
Model helicopters	164
Appendix	
Appendix.....	170
Conformity declaration.....	174
Guarantee certificate	175

Safety Notes

Please read carefully!

We all want you to have many hours of pleasure in our mutual hobby of modelling, and safety is an important aspect of this. It is absolutely essential that you read right through these instructions and take careful note of all our safety recommendations. We also strongly recommend that you register without delay at http://www.graupner.de/en/service/product_registration, as this ensures that you automatically receive the latest information relating to your product by e-mail.

If you are a beginner to the world of radio-controlled model aircraft, boats and cars, we strongly advise that you seek out an experienced modeller in your field, and ask him or her for help and advice.

If you ever dispose of this transmitter, these instructions must be passed on to the new owner.

Application

This radio control system may only be used for the purpose for which the manufacturer intended it, i.e. for operating radio-controlled models which *do not carry humans*. No other type of use is approved or permissible.

Safety notes

SAFETY IS NO ACCIDENT
and

RADIO-CONTROLLED MODELS
ARE NOT PLAYTHINGS

Even small models can cause serious personal injury and damage to property if they are handled incompetently, or if an accident occurs due to the fault of others.

Technical problems in electrical and mechanical systems can cause motors to rev up or burst into life unexpectedly, with the result that parts may fly off at great speed, causing considerable injury.

Short-circuits of all kinds must be avoided at all times.

Short-circuits can easily destroy parts of the radio control system, but even more dangerous is the acute risk of fire and explosion, depending on the circumstances and the energy content of the batteries.

Aircraft and boat propellers, helicopter rotors, open gearboxes and all other rotating parts which are driven by a motor or engine represent a constant injury hazard. Do not touch these items with any object or part of your body. Remember that a propeller spinning at high speed can easily slice off a finger! Ensure that no other object can make contact with the driven components.

Never stand in the primary danger zone, i.e. in the rotational plane of the propeller or other rotating parts, when the motor is running or the drive battery is connected.

Please note that a glowplug engine or electric motor could burst into life accidentally if the receiving system is switched on when you are transmitting the transmitter. To be on the safe side, disconnect the fueltank or the flight battery.

Protect all electronic equipment from dust, dirt, damp, and foreign bodies. Avoid subjecting the equipment to vibration and excessive heat or cold. Radio control equipment should only be used in "normal" ambient temperatures, i.e. within the range -15°C to $+55^{\circ}\text{C}$.

Avoid subjecting the equipment to shock and pressure. Check the units at regular intervals for damage to cases and leads. Do not re-use any item which is damaged or has become wet, even after you have dried it out thoroughly.

Use only those components and accessories which we expressly recommend. Be sure to use only genuine matching *Graupner* connectors of the same design with contacts of the same material.

When deploying cables ensure that they are not under

strain, are not tightly bent (kinked) or broken. Avoid sharp edges, as they can chafe through insulating materials.

Before you use the system, check that all connectors are pushed home firmly. When disconnecting components, pull on the connectors themselves – not on the wires.

It is not permissible to carry out any modifications to the RC system components, as any such changes invalidate both your operating licence and your insurance cover.

Installing the receiving system

In a model aircraft the receiver must be packed in soft foam and stowed behind a stout bulkhead, and in a model boat or car it should be protected effectively from dust and spray.

The receiver must not make direct contact with the fuselage, hull or chassis at any point, otherwise motor vibration and landing shocks will be transmitted directly to it. When installing the receiving system in a model with a glowplug or petrol engine, be sure to install all the components in well-protected positions, so that no exhaust gas or oil residues can reach the units and get inside them. This applies above all to the ON / OFF switch, which is usually installed in the outer skin of the model.

Secure the receiver in such a way that the aerial, servo leads and switch harness are not under any strain. The receiver aerial should be at least 5 cm away from all large metal parts and any wiring which is not connected directly to the receiver. This includes steel and carbon fibre components, servos, electric motors, fuel pumps, cabling of all kinds, etc..

Ideally the receiver should be installed well away from

Safety Notes

any other installed equipment in the model, but in an easily accessible position. Under no circumstances allow servo leads to run close to the aerial, far less coiled round it!

Ensure that cables are fastened securely, so that they cannot move close to the receiver aerial when the model is flying.

Deploying the receiver aerial(s)

The receiver and its aerials should be installed as far away as possible from all kinds of power system. If your model has a carbon fibre fuselage, the aerial tips must always be deployed outside the fuselage. The orientation of the aerial(s) is not critical, but we recommend installing them vertically (upright) in the model. If the receiver features aerial diversity (two aerials), the second aerial should be arranged at 90° to the first.

Installing the servos

Always install servos using the vibration-damping grommets supplied. The rubber grommets provide some degree of protection from mechanical shock and severe vibration.

Installing control linkages

The basic rule is that all linkages should be installed in such a way that the pushrods move accurately, smoothly and freely. It is particularly important that all servo output arms can move to their full extent without fouling or rubbing on anything, or being obstructed mechanically at any point in their travel.

It is essential that you should be able to stop your motor at any time. With a glow motor this is achieved by adjusting the throttle so that the barrel closes completely when you move the throttle stick and trim to their end-points.

Ensure that no metal parts are able to rub against each other, e. g. when controls are operated, when parts rotate, or when motor vibration affects the model. Metal-to-metal contact causes electrical “noise” which can interfere with the correct working of the receiver.

Directing the transmitter aerial

Transmitter field strength is at a minimum in an imaginary line extending straight out from the transmitter aerial. It is therefore fundamentally misguided to “point” the transmitter aerial at the model with the intention of obtaining good reception.

When several radio control systems are in use on adjacent channels, the pilots should always stand together in a loose group. Pilots who insist on standing away from the group endanger their own models as well as those of the other pilots.

However, if two or more pilots operating 2.4 GHz radio control systems stand closer together than 5 m, the down-link channel may be swamped, triggering a very premature range warning. If this should occur, walk away from the other pilots until the range warning ceases again.

Pre-flight checking

Before you switch on the receiver, ensure that the throttle stick is at the stop / idle end-point.

**Always switch on the transmitter first,
and only then the receiver.**

**Always switch off the receiver first,
and only then the transmitter.**

If you do not keep to this sequence, i. e. if the receiver is at any time switched on when “its” transmitter is switched OFF, then the receiver is wide open to signals

from other transmitters and any interference, and may respond. The model could then carry out uncontrolled movements, which could easily result in personal injury or damage to property.

Please take particular care if your model is fitted with a *mechanical gyro*: before you switch your receiver off, disconnect the power supply to ensure that the motor cannot run up to high speed accidentally.

As it runs down, the gyro can generate such a high voltage that the receiver picks up apparently valid throttle commands, and the motor could respond by unexpectedly bursting into life.

Range checking

Before *every* session check that the system works properly in all respects, and has adequate range. Secure the model adequately, and ensure that no persons are standing in front of the model.

Carry out at least one complete function check on the ground, followed by a complete simulated flight, in order to show up any errors in the system and the model's programming. Be sure to read the notes on pages 62 and 70 in this regard.

When operating a model, i. e. when flying or driving, do not operate the transmitter without the aerial fitted. Check that the transmitter aerial is firmly seated.

Operating your model aircraft, helicopter, boat or car

Never fly directly over spectators or other pilots, and take care at all times not to endanger people or animals. Keep well clear of high-tension overhead cables. Never operate your model boat close to locks and full-size vessels. Model cars should never be run on public streets or motorways, footpaths, public squares etc..

Checking the transmitter and receiver batteries

It is essential to stop using the radio control system and recharge the batteries well before they are completely discharged. In the case of the transmitter this means – at the very latest – when the message “**battery needs charging**” appears on the screen, and you hear an audible warning signal.

It is vital to check the state of the batteries at regular intervals – especially the receiver pack. When the battery is almost flat you may notice the servos running more slowly, but it is by no means safe to keep flying or running your model until this happens. Always replace or recharge the batteries in good time.

Keep to the battery manufacturer’s instructions, and don’t leave the batteries on charge for longer than stated. Do not leave batteries on charge unsupervised. Never attempt to recharge dry cells, as they may explode.

Rechargeable batteries should always be recharged before every session. When charging batteries it is important to avoid short-circuits. Do this by first connecting the banana plugs on the charge lead to the charger, taking care to maintain correct polarity. Only then connect the charge lead to the transmitter or receiver battery.

Disconnect all batteries and remove them from your model if you know you will not be using it in the near future.

Capacity and operating times

This rule applies to all battery types: capacity diminishes with each charge. At low temperatures the battery’s internal resistance rises, and capacity falls. This means that its ability to deliver current and maintain voltage is reduced.

Frequent charging, and / or the use of maintenance programs, tends to cause a gradual reduction in battery capacity. We recommend that you check the capacity of all your rechargeable batteries at least every six months, and replace them if their performance has fallen off significantly.

Use only genuine *Graupner* rechargeable batteries!

Suppressing electric motors

All conventional (brushed) electric motors generate sparks between the commutator and the brushes, which cause more or less serious interference to the radio control system, depending on the type of motor. If an RC system is to work correctly, it is therefore important to suppress the electric motors, and in electric-powered models it is essential that every motor should be effectively suppressed. Suppressor filters reliably eliminate such interference, and should always be fitted where possible.

Please read the notes and recommendations supplied by the motor manufacturer.

Refer to the main *Graupner* FS catalogue or the Internet website at www.graupner.de for more information on suppressor filters.

Servo suppressor filter for extension leads

Order No. 1040

Servo suppressor filters are required if you are obliged to use long servo extension leads, as they eliminate the danger of de-tuning the receiver. The filter is connected directly to the receiver input. In very difficult cases a second filter can be used, positioned close to the servo.

Using electronic speed controllers

The basic rule is that the electronic speed controller

must be chosen to suit the size of the electric motor it is required to control.

There is always a danger of overloading and possibly damaging the speed controller, but you can avoid this by ensuring that the controller’s current-handling capacity is at least half the motor’s maximum stall current.

Particular care is called for if you are using a “hot” (i.e. upgrade) motor, as any low-turn motor (small number of turns on the winding) can draw many times its nominal current when stalled, and the high current will then burn out the speed controller.

Electrical ignition systems

Ignition systems for internal combustion engines can also produce interference, which has an adverse effect on the working of the radio control system.

Electrical ignition systems should always be powered by a separate battery – not the receiver battery.

Be sure to use effectively suppressed spark plugs and plug caps, and shielded ignition leads.

Keep the receiving system an adequate distance away from the ignition system.

Static charges

Lightning causes magnetic shock waves which can interfere with the operation of a radio control transmitter even if the thunderstorm actually occurs several kilometres away. For this reason ...

... cease flying operations immediately if you notice an electrical storm approaching. Static charges through the transmitter aerial can be life-threatening!

Caution

- In order to fulfil the FCC RF radiation regulations

Safety Notes

applicable to mobile transmitting apparatus, the equipment's aerial must be at least 20 cm from any person when the system is in use. We therefore do not recommend using the equipment at a closer range than 20 cm.

- Ensure that no other transmitter is closer than 20 cm from your equipment, in order to avoid adverse effects on the system's electrical characteristics and radiation pattern.
- The radio control system should not be operated until the Country setting has been set correctly at the transmitter. This is essential in order to fulfil the requirements of various directives - FCC, ETSI, CE etc. Please refer to the instructions for your particular transmitter and receiver for details of this procedure.
- Check all working systems and carry out at least one full range check on the ground before every flight, in order to show up any errors in the system and the model's programming.
- Never make any changes to the programming of the transmitter or receiver whilst operating a model.

Care and maintenance

Don't use cleaning agents, petrol, water or other solvents to clean your equipment. If the case, the aerial etc. gets dirty, simply wipe the surfaces clean with a soft dry cloth.

Components and accessories

As manufacturers, the company of *Graupner* GmbH & Co. KG recommends the exclusive use of components and accessories which have been tested by *Graupner* and approved for their capability, function and safety. If you observe this rule, *Graupner* accepts responsibility for the product.

***Graupner* cannot accept liability for non-approved components or accessories made by other manufacturers. It is not possible for *Graupner* to assess every individual item manufactured by other companies, so we are unable to state whether such parts can be used without incurring a safety risk.**

Liability exclusion / Compensation

It is not possible for *Graupner* to ensure that the user observes the installation and operation instructions, and the recommended conditions and methods when installing, operating, using and maintaining the radio control components. For this reason *Graupner* denies all liability for loss, damages or costs which arise through misuse or mishandling of this equipment, or are connected with such use in any way.

Unless obliged by law, *Graupner's* obligation to pay compensation, regardless of the legal argument employed, is limited to the invoice value of that quantity of *Graupner* products which were immediately involved in the event in which the damage occurred, unless the company is deemed to have unlimited liability on account of deliberate or gross negligence.

The sole purpose of this manual is to provide information; it is subject to amendment without prior notification. *Graupner* accepts no responsibility or liability for errors or inaccuracies which may occur in the information section of this manual.

Environmental protection

This symbol on the product, in the operating instructions or the packaging indicates that the product must not be discarded via the normal household refuse at the end of its useful life. Instead it must be taken to a collection point for the recycling of electrical and electronic apparatus.

The materials can be re-used according to their identification code. You can make an important contribution to the protection of our shared environment by recycling old equipment and making use of its basic materials.

Dry and rechargeable batteries must be removed from the device and taken to the appropriate collection point.

Please ask your local authority for the location of your nearest waste disposal site.



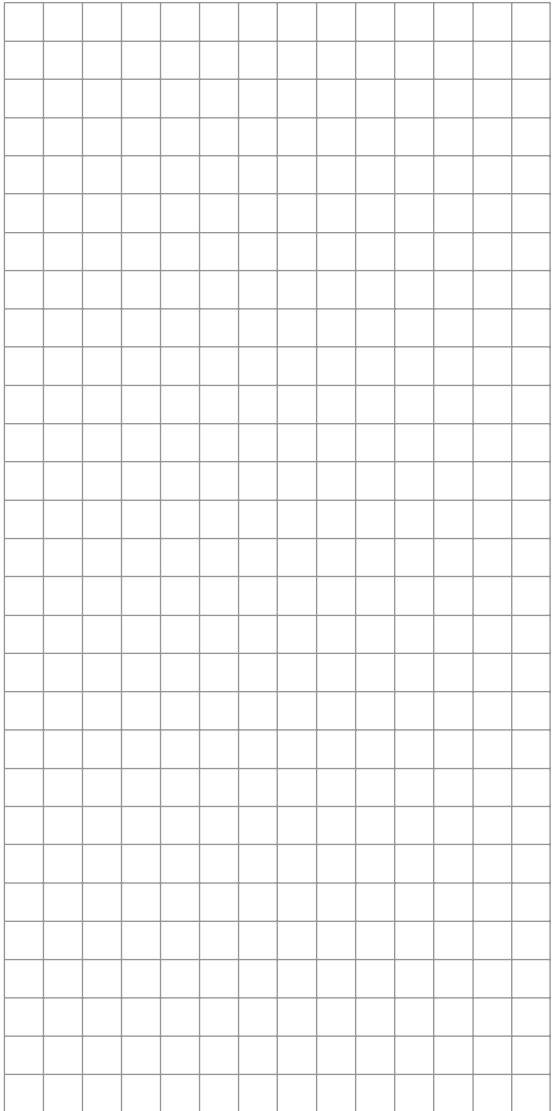
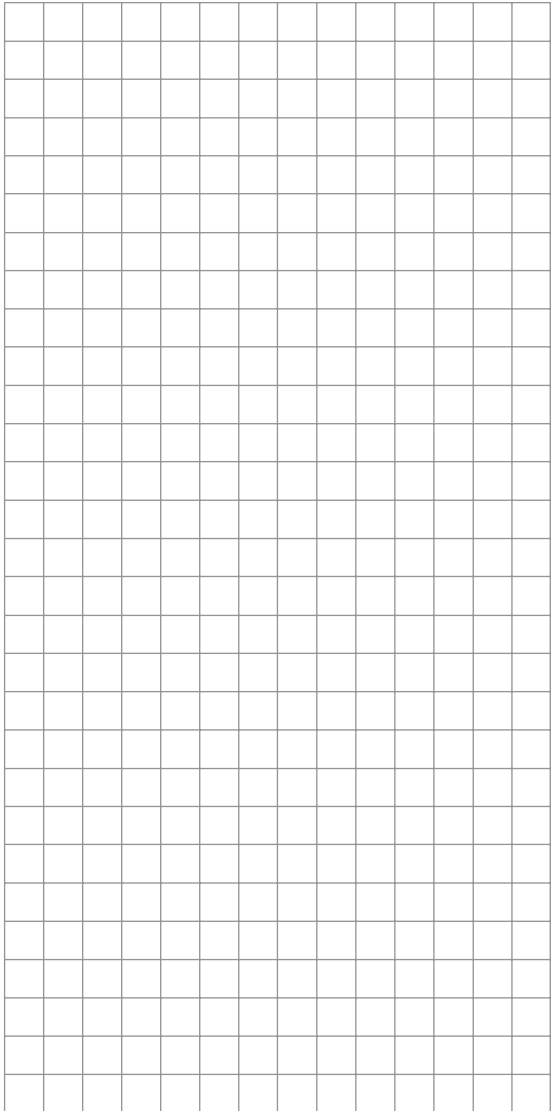
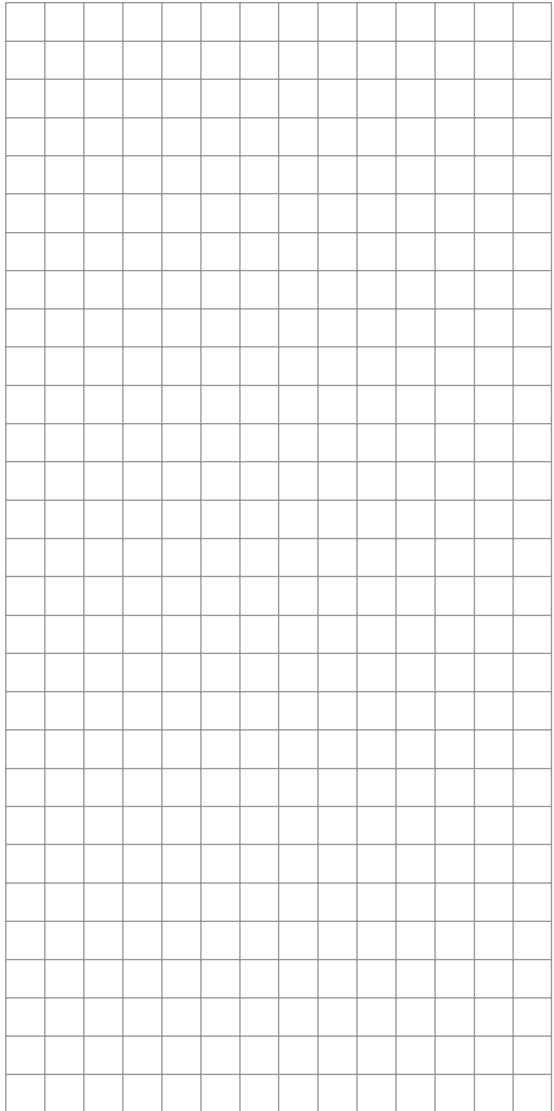

Safety notes and handling instructions relating to Nickel-Metal-Hydride rechargeable batteries

As with all sophisticated technical products, it is vitally important that you observe the following safety notes and handling instructions if you wish the equipment to operate safely and reliably for an extended period.

Safety notes

- Individual cells and rechargeable batteries are not playthings, and must be kept well away from children. Store rechargeable cells and batteries out of the reach of children.
- Check that the batteries are in perfect, serviceable condition before every use. Do not re-use defective or damaged cells or batteries.
- Rechargeable cells and batteries must be used within the specified limits stated for the corresponding cell type.
- **Do not heat, incinerate or short-circuit rechargeable cells or batteries, and never charge them with excessive currents or reversed polarity.**
- **Never use rechargeable batteries consisting of parallel-wired cells, combinations of old and new cells, cells of different construction, size, capacity, make, brand or cell type.**
- Batteries installed inside equipment should always be removed from the device when it is not in use and not about to be used. Always keep equipment switched off in order to avoid deep-discharged cells. Batteries must be recharged in good time.
- The battery to be charged should be placed on a non-inflammable, heat-resistant, non-conductive surface for the whole of the charge period. Keep inflammable and volatile objects and materials well clear of the charging area.
- Batteries must always be supervised when on

charge. Never exceed the maximum fast-charge current specified for the cell type in use.

- If the battery heats up to more than 60°C whilst on charge, halt the charge process immediately and allow the pack to cool down to about 30°C.
- Never recharge a battery which is already charged, hot, or not completely discharged.
- Do not make any modifications to batteries. Never solder or weld directly to cells.
- If incorrectly handled, rechargeable batteries are at risk of combustion, explosion, corrosive action and burns. Suitable extinguishing materials include fire blankets, CO2 fire extinguishers and sand.
- Escaped electrolyte is corrosive - do not allow it to contact skin or eyes. In an emergency rinse the area immediately with plenty of clean water before seeking medical help.
- In hermetically sealed spaces such as airtight boats, Ni-MH batteries are only of limited suitability, as hydrogen can escape from the cells (explosion risk). Good ventilation and cooling are necessary, especially where continuous currents lie above 30 A.
- The cells' air vents must never be blocked or sealed, e.g. by solder. When soldering, the iron temperature should not exceed 220°C, and each joint should be completed in less than twenty seconds.
- To avoid cell deformation, do not exert excessive mechanical pressure on battery cells.
- If a battery should be accidentally overcharged, use the following procedure:
Simply disconnect the battery and leave it on a non-inflammable surface (e.g. stone floor) until it has cooled down. Never hold the battery in your hand, as

there is a risk that cells might explode.

- Always observe the recommended rates for charging and discharging.

General information

The capacity of your rechargeable battery diminishes with every charge / discharge process. Stored batteries may eventually exhibit reduced capacity.

Storage

Batteries should not be stored in a completely discharged state. Store them in a dry enclosed space at an ambient temperature of +5°C to +25°C. If you are storing a battery for a period longer than four weeks, ensure that the cell voltage does **not fall below 1.2 V**

Balancing individual battery cells

- To balance new battery cells, i.e. to bring them all to the same state of charge, charge them at what is known as the 'normal' rate until they are full. As a general guideline a fully discharged battery needs to be charged for a period of twelve hours at a current corresponding to one tenth of the capacity printed on the cell label (the "1/10C" method). After this treatment all the cells will be fully charged, and exhibit the same voltage. This method of balancing battery cells should be repeated after every ten fast-charge processes, so that the cells are repeatedly balanced; this helps to ensure an extended useful life for your batteries.
- If you have the facilities to discharge individual cells, we recommend that you make use of this before every charge process. Otherwise the battery pack should be run down to a discharge voltage of 0.9 V per cell. For example, this equates to a final discharge voltage of 5.4 V for a six-cell pack.

Charging

Ni-MH batteries should only be charged using the specified currents, charge times and temperature range, and should be supervised constantly when on charge. If you do not have access to a suitable fast charger, i.e. one which allows you to set the charge current accurately, then the battery should always be recharged using the "normal" charge rate of 1/10C; see the example stated above.

Wherever possible, transmitter batteries should always be recharged at the 1/10C rate, in order to avoid differences in cell states. The charge current must never exceed the maximum permissible value stated in the transmitter instructions.

Temperature charging

You can use this method if you have access to a suitable battery charger with temperature cut-off system, fitted with a temperature sensor. However, the battery should always be taken out of the device beforehand.

Cut-off temperature when charging at 1C: maximum 40 ... 50°C.

- Never charge to a higher temperature than 60°C, and ensure that the temperature sensor has good, reliable contact with the battery. Check that the correct temperature is displayed, and that the charge process is terminated at the correct point. For this reason the temperature sensor should be as small as possible; if in any doubt, set a cut-off temperature 10 ... 15°C lower than stated above.

Note:

Charging to a temperature higher than 45°C causes a slight reduction in the effective life of the cells.

- **Never start a new charge process if the battery is**

already or still warm.

- **Never leave batteries on charge unsupervised.**

Fast charging

- The delta peak charge cut-off voltage should be set to 10 ... 20 mV per cell. Most battery chargers are set to a fixed cut-off value of 15 ... 20 mV per cell by default, which makes them suitable for use with NiCd and Ni-MH batteries. If you are not sure about this, please refer to the operating instructions supplied with your charger, or ask at your local model shop whether your charger is also suitable for Ni-MH packs. If in any doubt, charge your batteries at half the stated maximum charge current.
- It is always best to charge your batteries immediately before you plan to use them, as Ni-MH packs only deliver their optimum performance directly after charging, i.e. when still warm (40 to 50°C). These batteries exhibit a high rate of self-discharge, and quickly lose 10 ... 30% of their capacity over just a few hours. The internal resistance of Ni-MH cells also rises enormously when they are cold.

Discharging

All rechargeable batteries sold by *Graupner* and *GM-Racing* are suitable for a maximum continuous current load of 6C ... 13C, according to battery type (refer to the manufacturer's specification!). The higher the continuous current load, the shorter the batteries' useful life.

- Use your battery until its performance falls off, or until the low voltage warning is triggered.

Caution:

When stored for a long period, the cell voltage should not be allowed to fall below 1.2 V. This means that you may have to recharge the battery before stor-

ing it.

- Reflex charging and charge / discharge (cycle) programs shorten the effective life of batteries unnecessarily, and are only suitable for checking battery quality or "reviving" relatively old cells. It also makes no sense to charge / discharge a battery before using it - unless you simply wish to check its quality.

Disposal of exhausted dry and rechargeable batteries

The German Battery Order places a legal requirement on every consumer to return all used and exhausted dry cells and rechargeable batteries. It is prohibited to dispose of these items in the ordinary domestic waste. At no charge to the user, old dry and rechargeable batteries can be surrendered at local authority collection points, *Graupner* retail outlets, and any other shop where dry and rechargeable batteries of the same type are sold. You can also send batteries supplied by us to the following address - with adequate pre-paid postage - for disposal:

Graupner GmbH & Co. KG

Service: Gebrauchte Batterien (Used batteries)

Henriettenstr. 94 - 96

D-73230 Kirchheim unter Teck

You can make an important contribution to environmental protection in this way.

Caution:

Damaged batteries may require special packaging before despatch, as some contain highly toxic materials!!!!

mx-16 ~~HoTT~~ the latest generation of radio control technology

HoTT (Hopping Telemetry Transmission) is the synthesis of expertise, engineering and world-wide testing by professional pilots. The equipment operates on the 2.4 GHz band, and offers bi-directional communication between transmitter and receiver via a down-link channel integrated into the receiver.

The **mx-16** HoTT RC system is based on the *Graupner/JR mc-24* computer radio control system which was introduced back in 1997. It has been developed specifically for the beginner, but the **mx-16** HoTT is still capable of controlling all current model types without problem - whether fixed-wing model or helicopter, model boat or car.

In the area of fixed-wing models and helicopters it is often necessary to employ complex mixer functions for the control surfaces or the swashplate actuation system. Computer technology enables you to activate a vast range of functions to cope with special model requirements – just by pressing a button. With the **mx-16** HoTT all you do is select the appropriate model type, and the software then presents you automatically with the appropriate mixer and coupling functions. This means that the transmitter requires no additional modules in order to implement complex coupled functions, and you can forget all about old-fashioned mechanical mixers in the model. The **mx-16** HoTT provides an extremely high level of safety and reliability in use.

The **mx-16** HoTT offers twenty model memories, each of which can store model settings for different flight phases. Individual phases can be called up in flight simply by operating a switch, so that you can try out various settings quickly and without risk. This can be for test purposes or for varying parameters for different phases of flight.

The large graphic screen makes operating the transmitter a simple, intuitive process. Mixers and other functions can be displayed in graphic form, and this is extraordinarily helpful.

The beginner quickly becomes familiar with the different functions thanks to the clear, logically arranged program structure. Four-way touch-sensitive buttons to left and right of the high-contrast screen are used to enter settings, allowing the user to exploit all the options he needs, in accordance with his experience in handling radio-controlled models.

In theory the *Graupner* HoTT process allows more than 200 models to be operated simultaneously. Although in practice the mixed operation of different technical systems in the 2.4 GHz ISM band – as required by the approval regulations – reduces this number considerably. Generally, however, it will always be possible to operate even more models simultaneously on the 2.4 GHz band than on the 35 / 40 MHz frequency bands which we have used to date. However, the actual limiting factor – as it has always been – is likely to remain the size of the (air-) space available. The simple fact that no frequency control procedure is necessary equates to an enormous gain in safety, especially at flying sites such as gliding slopes where groups of pilots may be distributed over a large area, with nobody in overall control.

The integral Telemetry menu provides a simple means of accessing data and programming HoTT receivers. For example, this method can be used to map receiver outputs, distribute control functions to multiple servos, and match servo travels and directions to each other.

This manual describes each menu in detail, and also provides dozens of useful tips, notes and programming examples to complement the basic information. More

general modelling terms, such as Transmitter controls, Dual-Rates, Butterfly (Crow) and many others, are all explained in the manual.

Please refer to the Appendix for additional information on the HoTT system. This manual concludes with the transmitter's conformity declaration and guarantee certificate.

Please read the safety notes and the technical information. We recommend that you read right through the instructions with great care, and check all the functions as described in the text. This can be carried out simply by connecting servos to the supplied receiver, and watching their response as you program the transmitter. However, please read the notes on page 20 in this regard. This is the quickest method of becoming familiar with the essential procedures and functions of the **mx-16** HoTT.

Always handle your radio-controlled model with a responsible attitude to avoid endangering yourself and others.

The *Graupner* team wishes you great pleasure and success with your **mx-16** HoTT - a radio control system of the latest generation.

Kirchheim-Teck, March 2011

mx-16 HoTT Computer System

Eight-channel radio control set with *Graupner* HoTT 2.4 GHz technology (Hopping Telemetry Transmission)



Graupner HoTT technology offers extreme reliability in use, with bi-directional communication between transmitter and receiver, integrated telemetry, speech output via earphone socket and ultra-fast response times.

Simplified programming technology with capacitive programming touch-buttons.

High-contrast, eight-line graphic screen with blue

backlighting for ultra-clear display of all set-up parameters and telemetry data. Telemetry data is stored on a micro-SD memory card.

12-bit / 4096-step channel signal resolution for extremely fine control characteristics.

USB socket for reading out and saving model memory data, and loading firmware updates.

- Micro-computer radio control system exploiting the latest *Graupner* HoTT 2.4 GHz technology
- Bi-directional communication between transmitter and receiver
- Five different languages
German and English; subsequent software updates will offer French, Italian and Spanish.
- Ultra-fast response times through direct, ultra-reliable data transmission from the main processor to the 2.4 GHz RF module. No additional delay caused by detours through a module processor.
- Telemetry menu for displaying telemetry data, and programming receiver outputs and optional sensors.
- Telemetry display shows numerous programming and analysis functions directly on the transmitter screen.
- Speech output can be called up using freely programmable switches
- User-selectable servo cycle times for digital servos, min. 10 ms
- Short, folding aerial
- Methods of operation and programming based on the proven concepts of the **mc-19** to **mc-24**
- High-contrast graphic screen with blue backlighting ensures perfect monitoring of set-up parameters, such as model type, model memory, timers and operating voltage.
- Function encoder with two four-way touch-sensitive buttons for simplified programming and accurate settings
- Key-Lock function to guard against accidental operation.
- Four programmable flight phases
- Twenty model memories, with storage of all model-

mx-16 Computer System

Eight-channel radio control set with *Graupner* HoTT 2.4 GHz technology (**Hopping Telemetry Transmission**)

- specific programming and set-up parameters
- Seven switches (two three-way switches, three two-way switches and two momentary switches), plus three digital controls - already installed and extremely versatile
- Unrestricted assignment of all switches to switched functions simply by operating the appropriate switch
- Internal real-time clock for dating log files
- User-replaceable CR2032 buffer battery for internal real-time clock
- Storage of model memories using the latest battery-free back-up system
- Eight control functions with simplified, very convenient assignment of transmitter controls for auxiliary functions, such as switches and proportional controls
- Convenient mode selector provides simple method of changing the stick mode (modes 1 - 4, e. g. throttle right / throttle left).

When you change modes, all the affected settings are switched at the same time.

- Graphical servo display provides a straightforward overview of the servo set-up, and a swift method of checking servo travels
- Receiver output swap
- Comprehensive programs for fixed-wing model aircraft and helicopters:
Fixed-wing menu for: 1 AIL, 2 AIL, 2 AIL + 2 FLAP, V-tail, delta / flying wing, two elevator servos
Fixed-wing mixer: diff aile, diff.flaps, ail → rudd, ail → flaps, brake → elev, brake → flap, brake → aile, elev → flap, elev → aile, flap → elev, flap → aile and diff. reduction
- Heli menu: 1-point, 2-point, 3-point and 4-point

- linkages (1 servo, 2 servo, 3sv(2roll), 3sv(140°), 3sv(2nick (pitch-axis)), 4 SV (90°))
- Swashplate limiter
- Servo travel adjustment +/- 150% for all servo outputs, variable separately for each side (Single Side Servo Throw)
- Variable sub-trim, range +/- 125%, for adjusting the neutral position of all servos
- Servo reverse, programmable for all servos
- EXPO / DUAL-RATE system, separately variable, can be switched in-flight, flight phase programmable
- Stopwatch / count-down timer with alarm function
- Model memory copy function
- Integral DSC socket for use with flight simulators and Trainer systems

General features of the HoTT system

- Simple, ultra-fast binding of transmitter and receiver
- Multiple receivers can be bound per model for parallel operation
- Extremely fast re-binding, even at maximum range
- Two-receiver satellite operation using special cable connection
- Range-check and warning function
- Receiver low-voltage warning on transmitter screen
- Ultra-wide receiver operating voltage range: 3.6 V to 8.4 V (fully operational down to 2.5 V)
- Fail-Safe
- Unrestricted channel assignment (channel-mapping), mixer functions and all servo settings programmable in the Telemetry menu
- Up to four servos can be actuated simultaneously as a block, with a servo cycle time of 10 ms (digital

servos only)

- Optimised frequency hopping and broad channel spread for maximum interference rejection
- Intelligent data transmission with corrective function
- Real-time telemetry analysis
- More than 200 systems can be operated simultaneously
- Future-proof update capability using USB port

Set contents

Order No. **33116**:

mx-16 HoTT micro-computer transmitter with integral 4NH-2000 RX RTU flat-pack Ni-MH transmitter battery (specification reserved), *Graupner* GR-16 HoTT bi-directional receiver, switch harness and plug-type battery charger

Recommended battery chargers (optional)

Order No.	Description	220 V mains conn.	12 V DC connect.	Suitable for the following battery types				Integral charge. lead
				NiCd	Ni-MH	LiPo	Lead-ac.	
6407	Multilader 3	x		x	x			x
6411	Ultramat 8	x	x	x	x	x		
6425	Twin Charger	x			x			
6427	Multilader 3	x		x	x			x
6455	Multilader 7E	x		x	x		x	
6463	Ultramat 12 plus Pocket		x	x	x	x	x	
6464	Ultramat 14 plus	x	x	x	x	x	x	
6466	Ultra Trio plus 14	x	x	x	x	x	x	
6468	Ultramat 16S	x	x	x	x	x	x	
6470	Ultramat 18	x	x	x	x	x	x	

To recharge the **mx-16iFS** system you will also need the transmitter charge lead, Order No. **3022**, and the receiver battery charge lead, Order No. **3021**, unless stated otherwise in the table.

For details of additional battery chargers, and details of the chargers listed here, please refer to the main *Graupner* FS catalogue, or our Internet site at www.graupner.de.

Specification, mx-16 HoTT transmitter

Frequency band	2,4 ... 2,4835 GHz
Modulation	FHSS
Transmitter power	see Country setting, page 115
Control functions	Eight functions; four with trims
Temperature range	-10 ... +55 °C
Aerial	folding
Operating voltage	3,4 ... 6 V
Current drain	approx. 180 mA
Dimensions	approx. 190 x 195 x 90 mm
Weight	approx. 770 g with transmitter battery

Accessories

Order No.	Description
1121	Neckstrap, 20 mm wide
70	Neckstrap, 30 mm wide
3097	Wind-shield for hand-held transmitter
	Trainer leads for mx-16 HoTT: see page 135

Replacement parts

Order No.	Description
2498.4FBEC	4NH-2000 RX RTU, flat-pack
33800	HoTT transmitter aerial

Specification, GR-16 HoTT receiver

Operating voltage	3,6 ... 8,4 V
Current drain	ca. 70 mA
Frequency band	2,4 ... 2,4835 GHz
Modulation	FHSS
Aerial	Diversity aerials, 2 x approx. 145 mm long, approx. 115 mm encapsu- lated and approx. 30 mm active
Servo sockets	8
Sensor socket	1
Temperature range	approx. -15° ... +70 °C
Dimensions	approx. 46 x 21 x 14 mm
Weight	approx. 12 g

Operating Notes

Transmitter power supply

The **mx-16** HoTT transmitter is fitted as standard with a high-capacity rechargeable 4NH-2000 RX RTU Ni-MH battery (Order No. **2498.4FBEC**) (specification reserved). **When delivered, the standard rechargeable battery is not charged.**

When you are using the transmitter you can monitor the battery voltage on the LCD screen. If the voltage of the transmitter battery falls below a certain point, you will hear an audible warning signal. The screen then displays a message reminding you that the transmitter battery needs to be recharged.

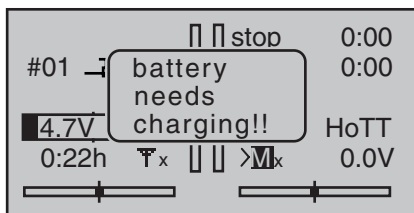

Always recharge the transmitter battery in good time. When you see this message, cease operations immediately and recharge the transmitter battery.

Charging the transmitter battery

The rechargeable Ni-MH transmitter battery can be recharged with the battery charger (Order No. **33116.2**) supplied in the set, using the charge socket located on the right-hand side of the transmitter. Leave the battery inside the transmitter for charging, to avoid premature damage to the internal battery socket.

As an approximate guideline a discharged battery should be charged for twelve hours at a current corresponding to one tenth of the capacity printed on the pack. If you are using the standard transmitter battery and the charger supplied in the set, this current is

200 mA.

The transmitter must be switched “OFF” for the whole period of the charge process. Never switch on the transmitter when it is still connected to the charger; even a very brief interruption in the process can cause the charge voltage to rise to the point where the transmitter is immediately damaged. For this reason check carefully that all connectors are secure, and are making really good contact.

Polarity of the mx-16 HoTT charge socket

Commercially available battery charge leads produced by other manufacturers are often made up with the opposite polarity. For this reason it is essential to use only the genuine *Graupner* charge lead, Order No. **3022**.



Using automatic battery chargers

Although the standard transmitter charge socket is protected against reversed polarity, it is still possible to use suitable chargers to fast-charge the transmitter battery. If possible, set the delta peak voltage difference of your fast charger to a value in the range 10 mV ... 20 mV or equivalent, as described in the charger's instructions; this ensures that it is suitable for fast-charging Ni-MH cells.

First connect the banana plugs on the charge lead to the charger, and only then connect the other end of the charge lead to the charge socket on the transmitter. When the charge lead is connected to the transmitter, never allow the bare ends of the plugs to touch! To avoid damage to the transmitter, the charge current must never exceed 1 A. If necessary, limit the current on the charger itself.

Removing the transmitter battery

To remove the transmitter battery, first disengage the cover over the battery compartment on the back of the transmitter, then lift it off:



Remove the battery, then carefully pull on the power lead to disconnect the transmitter battery connector.

Installing the transmitter battery

Hold the connector attached to the transmitter battery in such a way that the black or brown wire faces the aerial, and the unused socket of the battery connector is on the side facing the bottom, then push the battery connector onto the three pins projecting out of the inside of the transmitter, in the direction of the circuit board. (The battery connector is protected against reversed polarity by two chamfered edges; see illustration).

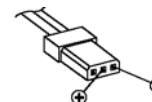

Polarity of transmitter battery connector

Finally place the battery in the compartment, and close the cover.

Battery timer, bottom left corner of the screen

This timer displays the cumulative operating time of the transmitter since the last time the transmitter battery was charged.

This timer is automatically reset to “0:00” when the transmitter detects that the voltage of the transmitter battery is significantly higher than the last time it was switched on, e. g. as a result of a charge process.

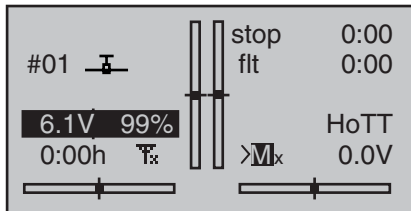

CR 2032 lithium battery

On the left-hand side of the transmitter circuit board you will find a holder fitted with a user-replaceable CR 2032 lithium battery:

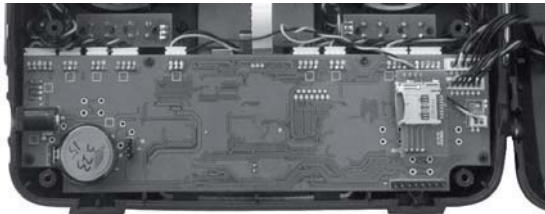

The purpose of this battery is to protect the system from loss of date and time if the transmitter's power supply is disconnected; for example, when the transmitter battery is replaced.

Operating Notes

Receiver power supply

A wide range of rechargeable four-cell and five-cell NiMH batteries varying in capacity is available for use as the receiver power supply. If you are using digital servos we recommend that you use a five-cell (6 V) pack of generous capacity. If your model is fitted with a mixture of digital and analogue servos, it is important to check the maximum permissible operating voltage of all the types. The PRX unit, Order No. **4136**, provides a stabilised receiver power supply with a user-variable voltage from one or two receiver batteries; see Appendix.

For reasons of safety battery boxes or dry cells should never be used.

The voltage of the airborne power supply is displayed on the transmitter screen while the model is flying:

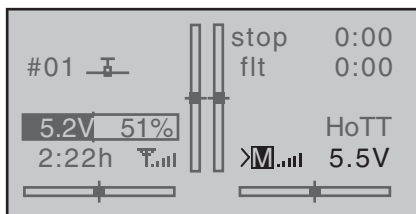

If the voltage falls below the pre-set warning threshold - 3.8 Volt as standard, but variable in the Telemetry menu; see page 126 - a visual and audible low-voltage warning is triggered.

Nevertheless it is important to check the state of the batteries at regular intervals. Don't put off charging the batteries until the warning signal is triggered.

Note:

Please refer to the main Graupner FS catalogue or visit the Internet site at www.graupner.de for full details of batteries, chargers, measuring equipment and battery monitor units.

Charging the receiver battery

The charge lead, Order No. **3021**, can be connected directly to the NC receiver battery for charging. If the battery is installed in a model and you have installed one of the following switch harnesses: Order No. **3046**, **3934** or **3934.1** or **3934.3**, the battery can be charged via the separate charge socket, or the charge socket which is built into the switch. The switch on the switch harness must be left at the "OFF" position for charging.

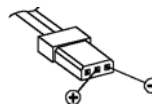

Polarity of the receiver battery connector

General notes on battery charging

- Observe the recommendations provided by the charger manufacturer and the battery manufacturer at all times.
- Keep to the maximum permissible charge current stated by the battery manufacturer.
- The maximum charge current for the transmitter battery is 1.5 A. Limit the charge current to this value on the charger.
- If you wish to charge the transmitter battery at a current higher than 1.5 A, you must first remove the pack from the transmitter, otherwise you risk damaging the circuit board through overloading the conductor tracks, and / or overheating the battery.
- Carry out a series of test charges to ensure that the automatic charge termination circuit works correctly with your battery. This applies in particular if you wish to charge the standard Ni-MH battery using an automatic charger designed for Ni-Cd batteries.
- You may need to adjust the Delta Peak trigger voltage, if your charger provides this option.

- Do not discharge the battery or carry out a battery maintenance program via the integral charge socket. The charge socket is not suitable for this application.
- Always connect the charge lead to the charger first, and only then to the transmitter or receiver battery. Observing this rule eliminates the danger of accidental short-circuits between the bare contacts of the charge lead plugs.
- If the battery becomes hot when on charge, it is time to check the pack's condition. Replace it if necessary, or reduce the charge current.
- **Never leave batteries unsupervised when on charge.**

Environmental protection notes

Important information on the disposal of dry and rechargeable batteries:

The German Battery Order places a legal requirement on every consumer to return all used and exhausted dry cells and rechargeable batteries. It is prohibited to dispose of these items in the ordinary domestic waste. At no charge to the user, old dry and rechargeable batteries can be surrendered at local authority collection points, *Graupner* retail outlets, and any other shop where dry and rechargeable batteries of the same type are sold. You can also send batteries supplied by us to the following address - with adequate pre-paid postage - for disposal:

Graupner GmbH & Co. KG
Service: Gebrauchte Batterien (Used batteries)
Henriettenstr. 94 - 96
D-73230 Kirchheim unter Teck

You can make an important contribution to environmental protection in this way.

Adjusting stick length

Both sticks are infinitely variable in length over a broad range, enabling you to set them to suit your personal preference.

Hold the bottom half of the knurled grip firmly, and unscrew the top section:

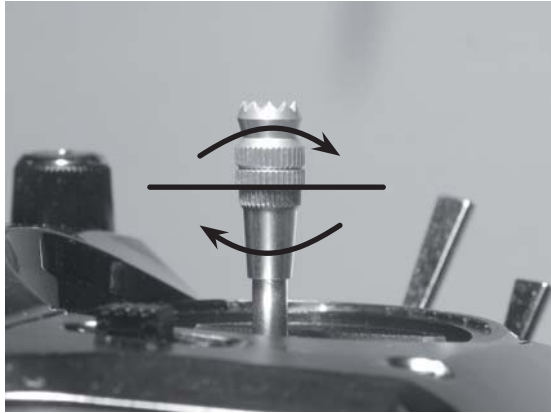

Now screw the stick top in or out (shorter or longer) to the length you prefer before tightening the top and bottom sections against each other to fix the stick top.

Opening the transmitter case

Please read the following notes carefully before you open the transmitter. If you have no experience in such matters, we recommend that you ask your nearest *Graupner* Service Centre to carry out the work for you.

The transmitter should only be opened in the following cases:

- When a self-neutralising stick needs to be converted to non-neutralising action, or a non-neutralising stick to a self-neutralising action.
- If you wish to adjust the stick centring spring tension.

Before opening the transmitter check that it is switched off (move Power switch to "OFF").

Open the battery compartment and remove the transmitter battery as described on the previous double-page. After this, use a PH1-size cross-point screwdriver to undo the six screws recessed into the back panel of the transmitter, as shown in the illustration:

Arrangement of the case back screws



Hold the two case sections together with your hand, and turn the unit over to allow these six screws to fall out onto the table. Now carefully raise the case back and fold it open to the right, as if you were opening a book.

CAUTION

Two multi-core cables connect the lower shell to the transmitter electronics located in the top section. Please take great care not to damage this cable!

Important:

- **Do not modify the transmitter circuit in any way, as this invalidates your guarantee and official approval for the system.**
- **Do not touch any part of the circuit boards with any metal object. Avoid touching the contacts with your fingers.**
- **Never switch the transmitter on while the case is open.**

Please note the following points when closing the transmitter:

- **Make sure that no cables are jammed between the transmitter case sections when you close the back.**
- **Check that the two case sections fit together flush all round before fitting the retaining screws. Never force the two case components together.**
- **Fit the case screws in the existing threads, and tighten them gently. Over-tightening them will strip the threads in the plastic.**

Operating Notes

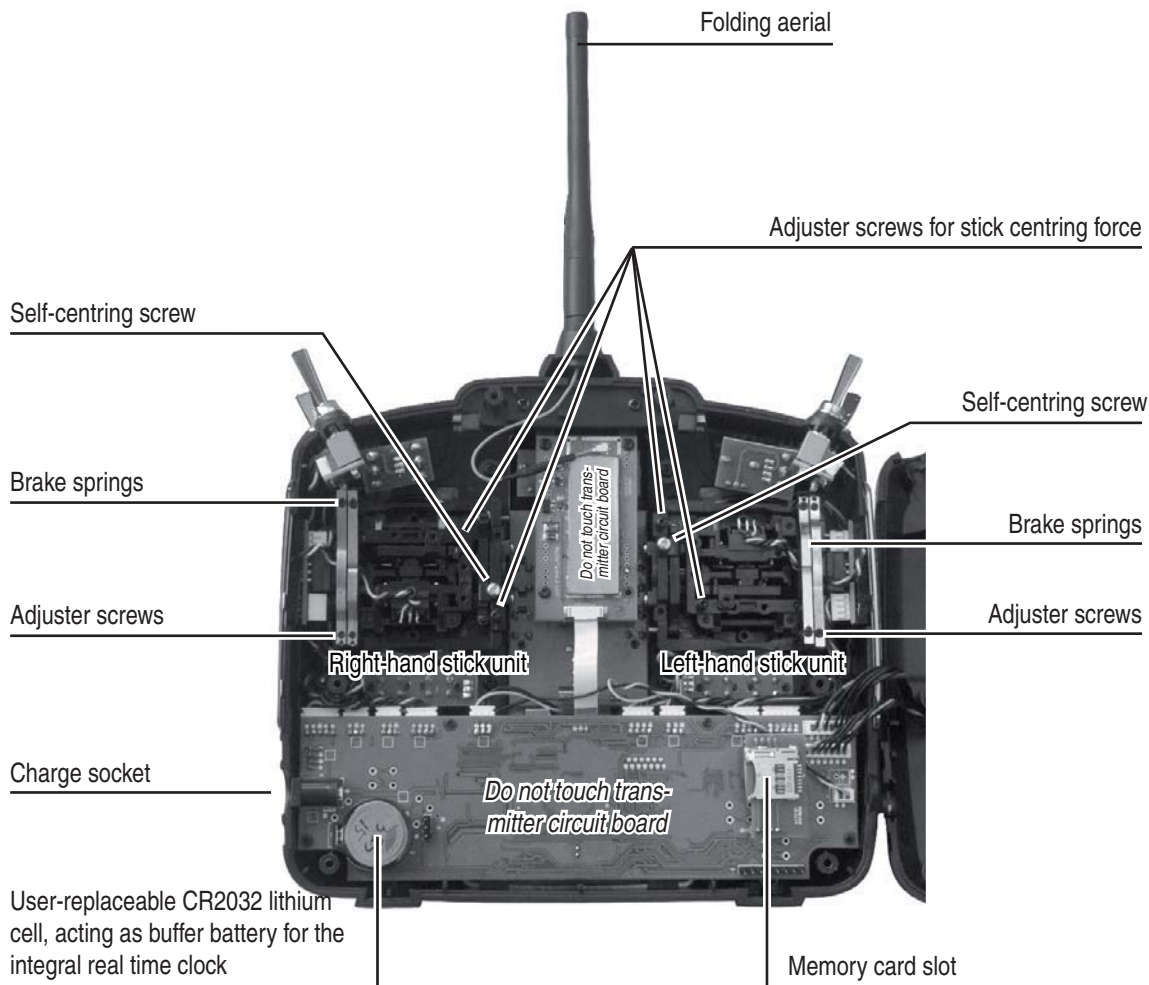

Converting the dual-axis stick units

Self-centring action

Either or both sticks can be converted from self-neutralising to non self-neutralising action: start by opening the transmitter as described on the previous page.

If you wish to change the standard stick unit arrangement, start by locating the screw on the left-hand stick unit shown circled in white in the photo below.

Note:

The right-hand stick unit is of mirror-image construction, i.e. the screw you require is located on the right, below centre.

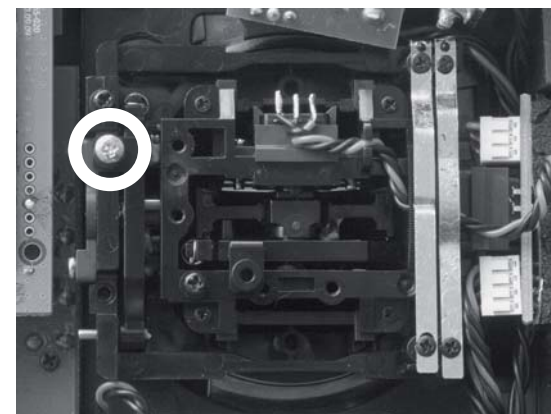

Turn this screw clockwise until the stick on that side moves freely from one end-stop to the other; alternatively unscrew it until the stick is fully self-centring again.

Brake spring and ratchet

You can alter the braking force of the stick by adjusting the outer of the two screws circled in white in the next picture; adjusting the inner screw alters the strength of the ratchet:

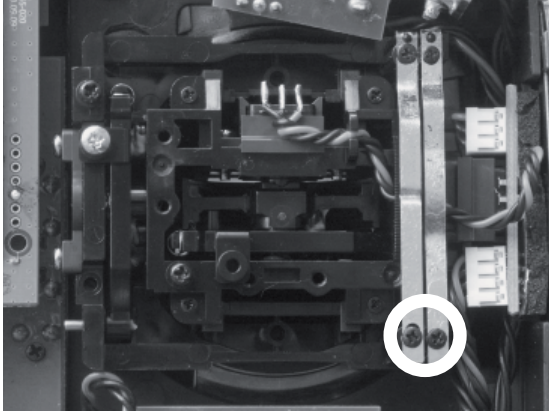

Note:
The right-hand stick unit is of mirror-image construction, i.e. the screw you require is located on the right, below centre.

Stick centring force

The centring force of the sticks is also variable to suit your preference. The adjustment system is located adjacent to the centring springs; see the white circles in the following photo.

You can set the preferred centring spring force by rotating the corresponding adjuster screw using a cross-point screwdriver:

- Turn to the right = harder spring tension;
- Turn to the left = softer spring tension.

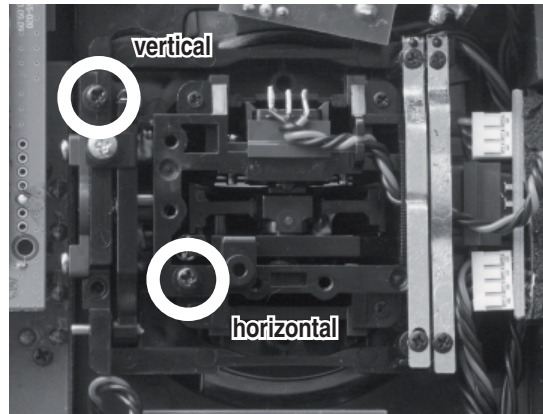

Note:
The right-hand stick unit is of mirror-image construction, i.e. the screw you require is located on the right, below centre.

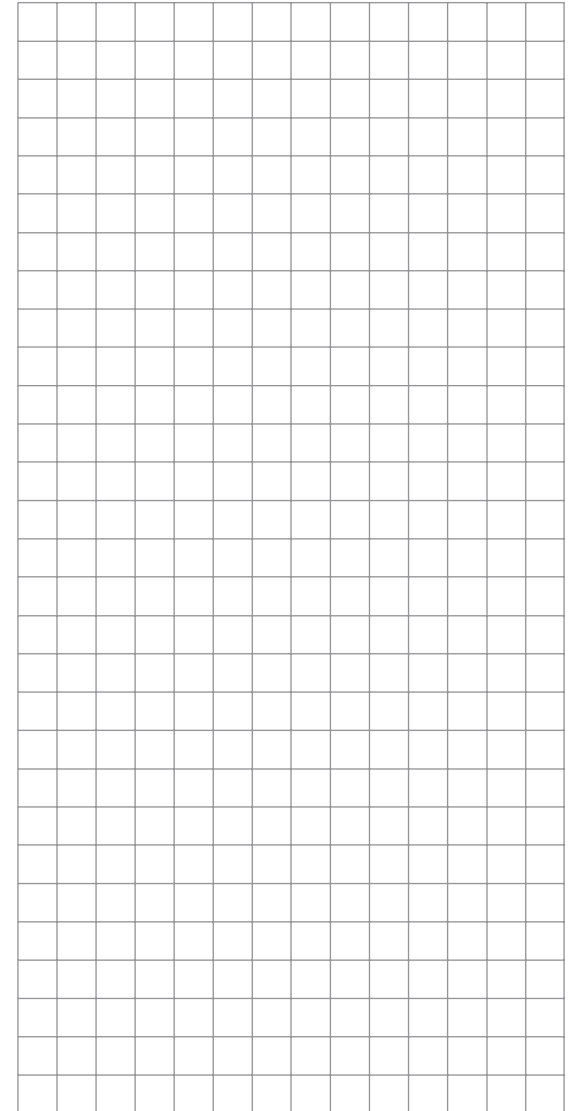

Description of transmitter

Transmitter controls

Attaching the transmitter neckstrap

You will find a strap lug mounted in the centre of the front face of the **mx-16** HoTT transmitter, as shown in the drawing on the right. This lug is positioned in such a way that the transmitter is perfectly balanced even when suspended from a neckstrap.

Order No. **1121** Neckstrap, 20 mm wide

Order No. **70** Neckstrap, 30 mm wide

Important note:

In the transmitter's standard form any servos connected to the receiver can initially only be operated using the dual-axis sticks. For maximum flexibility, all the other transmitter controls (CTRL 6 ... 8, SW 1 ... 9) are "free" in software terms, and can be assigned to any channels you like, enabling you to set up the system to suit your personal preference or the requirements of a particular model. This is carried out in the "**contr set.**" menu, as described on pages 74 (fixed-wing models) and 76 (model helicopters).

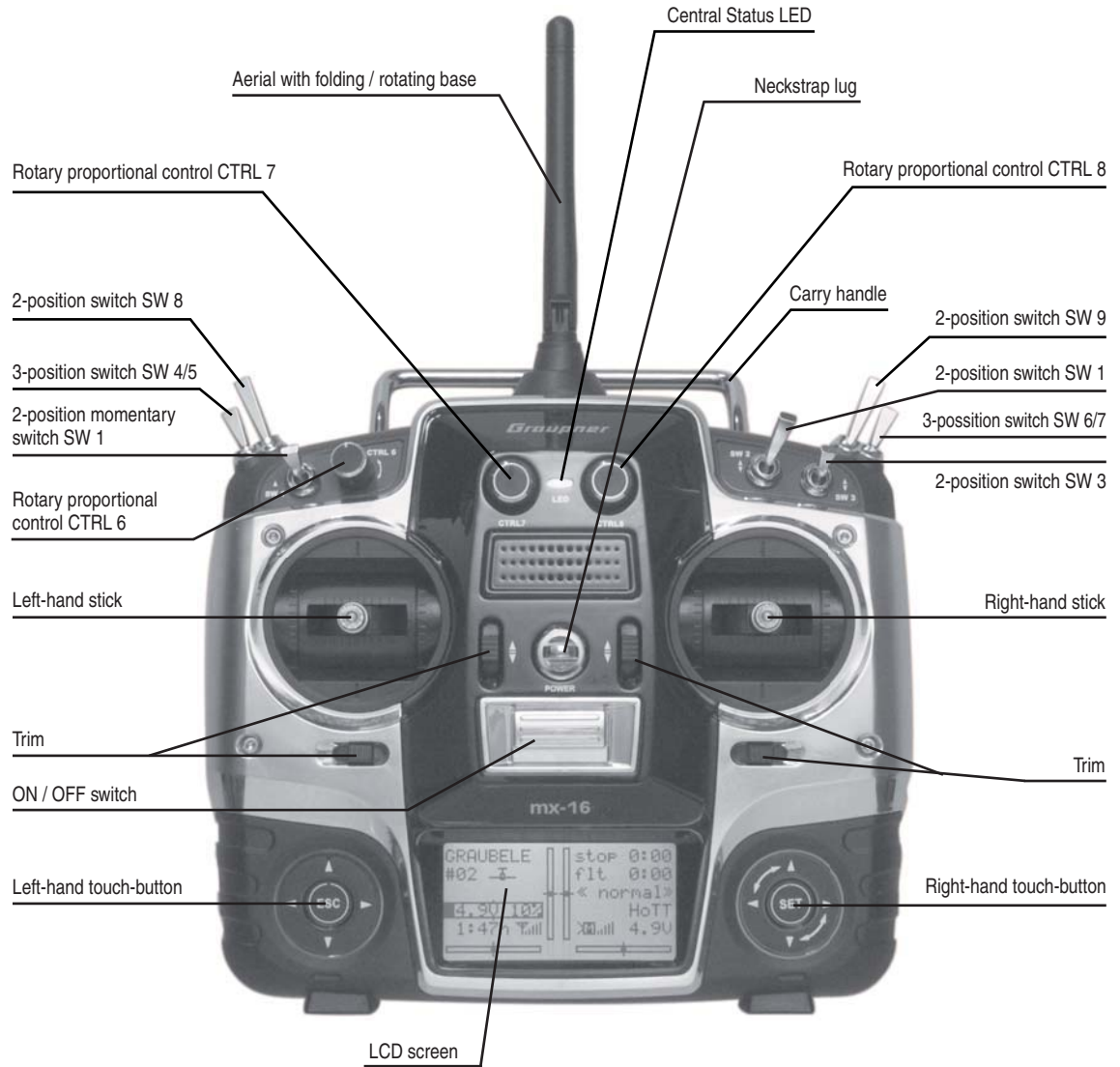



Headphone socket

The central socket at the bottom edge of the back panel name plate is intended for connecting a standard commercial earphone or headphones fitted with a 3.5 mm barrel plug (not included in the set).

Signals and voice messages associated with the Telemetry menu are generated via this socket, as are the transmitter's audible signals. The default language for speech output is German. For more information on this please refer to "Voice messages" in the "**HIDDEN MODE**" section starting on page 26, and the "**Telemetry**" section starting on page 130.

The volume of the headphone output can be adjusted in the "Voice volume" line of the "**General Settings**" menu; see page 115.

mini-USB socket

This socket can be used to connect the transmitter to a PC running Windows XP, Vista or 7. The software required at the PC, including a suitable USB driver, can be found in the Download section for that product at www.graupner.de.

Once you have installed the software required, you can update the transmitter via this connection as and when required, or simply set the correct date and time of day.

Data socket

For connecting the optional Smart-Box, Order No. 33700. For more details about the Smart-Box please refer to the main *Graupner FS* catalogue, or refer to that product on the Internet at www.graupner.de.

DSC

Direct Servo Control

The original function of this socket was for “Direct Servo Control”, and that’s why the abbreviation is still in use. However, for technical reasons “direct servo control” is no longer possible with the HoTT system using a diagnosis lead.

The **mx-16** HoTT transmitter’s standard two-pole DSC socket is now used as a Trainer (buddy box) socket (Teacher or Pupil), and as an interface for flight simulators.

For the DSC connection to work you must check the following:

1. Carry out any adjustments required in the appropriate menus:
See page 132 for information on setting up the **mx-16** HoTT transmitter to work as part of a Trainer system.
2. **ALWAYS** leave the transmitter’s On / Off switch in the “OFF” position when using a flight simulator, and when using the **mx-16** HoTT transmitter as a Pupil unit in a Trainer system, for only in this position is the RF section of the transmitter module switched off (no RF signal) even when the DSC lead is plugged in. At the same time the transmitter’s current drain is reduced slightly.

The central Status LED should now glow a constant red, and the abbreviation “DSC” appears in the transmitter’s base display on the left, below the model number. At the same time the display of telemetry symbols is suppressed:

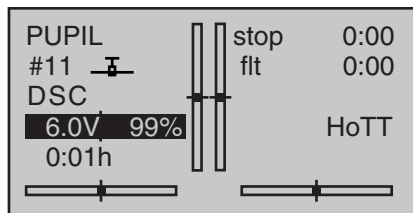

The transmitter is now ready for use.

In contrast, when the **mx-16** HoTT is used in Teacher mode, the transmitter must be switched on *before* the appropriate cable is plugged in.

3. Connect the other end of the connecting lead to the appropriate apparatus, taking into account the operating instructions supplied with that device.

Important:

Ensure that all connectors are firmly seated in their sockets.

Note regarding flight simulators:

The range of flight simulators available commercially is now very wide, and you may find that it is necessary to swap over certain contacts at the barrel connector or the DSC module. This work must be carried out by a Graupner Service Centre.

Data storage

Card slot

micro-SD and micro-SDHC

When you switch off the **mx-16** HoTT transmitter and remove the battery compartment cover, you will see the card slot for memory cards (of the micro-SD and micro-SDHC type) in the right-hand side of the compartment:

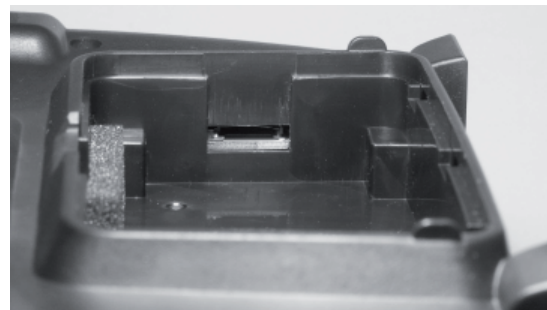

Any standard commercial micro-SD memory card with a capacity of up to 2 GB can be used, and also any micro-SDHC card of up to 32 GB. However, the manufacturer recommends the use of memory cards with capacities up to only 4 GB, as these are completely adequate in all normal circumstances.

The memory cards for which the transmitter is intended are familiar from their use in digital cameras and mobile telephones. Place the card in the slot with the contacts facing up, towards the back panel, and push it in until it locks. Re-install the battery and close the battery compartment; the transmitter can now be switched on again. The base display shows a stylised memory card symbol to indicate that a memory card is present:

Screen and keypad

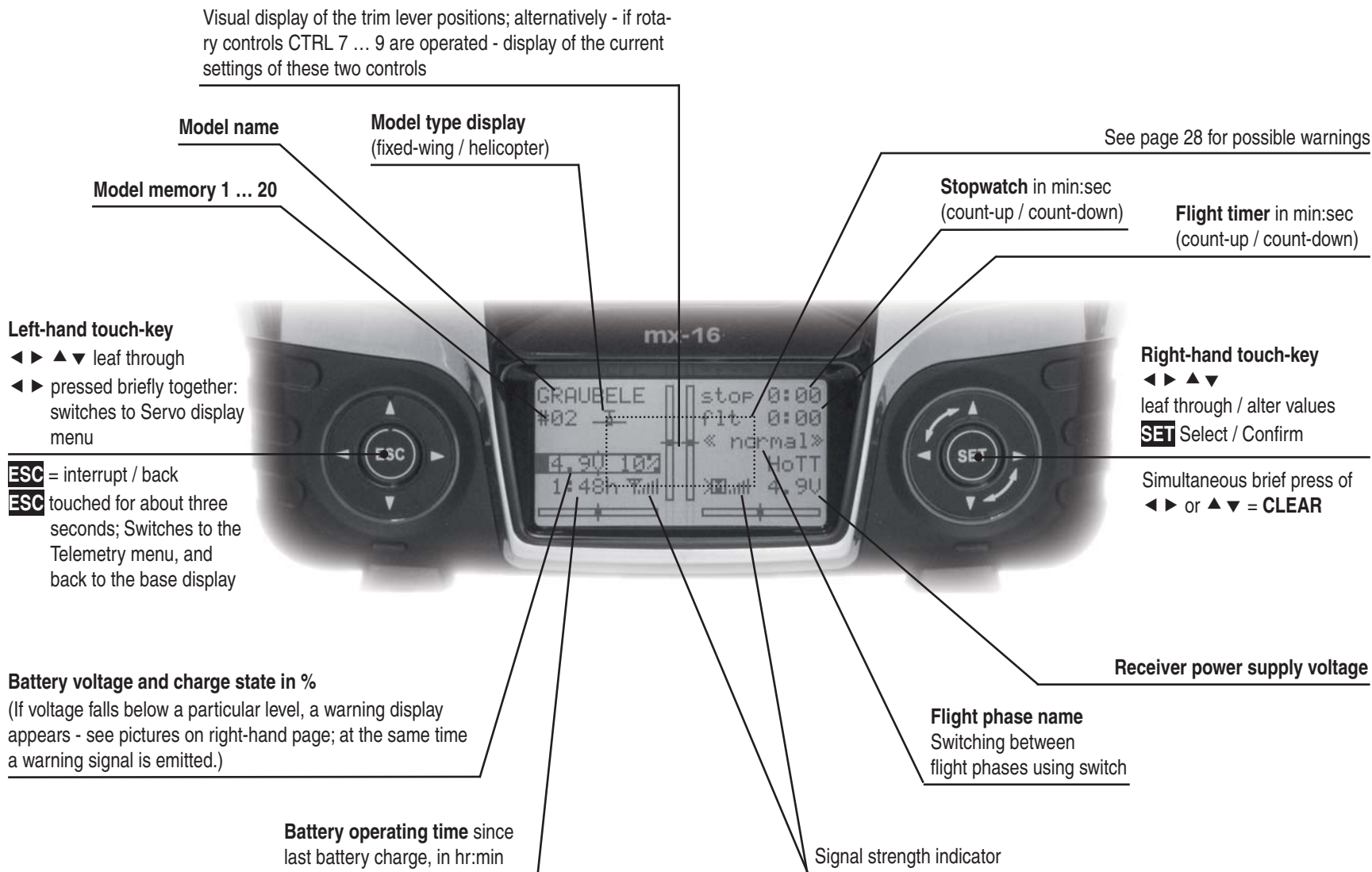

Operating the “Data Terminal”

Input buttons **ESC**, **SET**, **CLEAR**, symbols

On-screen telemetry symbols

- ☐ The active model memory is not yet “bound”
- ☐ Not flashing: RF switched off at transmitter
Flashing aerial symbol:
The last receiver bound to the active model is inactive, or out of range
- >M x No telemetry signal detected
- >M Signal strength display
- >P Display of Pupil signal strength on the Teacher transmitter’s screen.

Buttons to the left of the screen

- **ESC** button
A brief press on the **ESC** button returns you step by step within the function select system, taking you right back to the basic display. If you make a change in the meantime, the change is retained.
If touched for about three seconds in the base display, **ESC** opens and closes the Telemetry menu.
- Arrow buttons ◀ ▶ ▲ ▼
 1. A brief press on one of these buttons allows you to leaf through lists, such as the Model Select or Multi-Function list, always moving in the direction of the arrow; the arrow buttons are also used to move through menu lines within menus.
 2. A brief simultaneous press of the ◀ ▶ buttons switches from the base transmitter display, and from almost any menu position, into the “**Servo display**” menu.

Buttons to the right of the screen

- **SET** button
 1. Starting from the base screen display - as it appears when you switch the transmitter on - a brief press of the **SET** button takes you to the multi-function menus. You can also call up a selected menu using the **SET** button.
 2. Within the set-up menus you can activate (confirm) and disable the corresponding set-up fields with a brief press of the **SET** button.
- Arrow buttons ◀ ▶ ▲ ▼
 1. “Leafs through” the multi-function menu and the menu lines within the set-up menus, in the same manner as the left-hand touch-key’s arrow buttons.
 2. Selects and adjusts parameters in set-up fields after you have activated them by briefly pressing the **SET** button; the buttons ▶ ▲ and ◀ ▼ are assigned the same function in each case, i.e. it makes absolutely no difference which of the two buttons you use.
 3. A brief simultaneous press of the ▲ ▼ or ◀ ▶ buttons resets an altered parameter value in the active input field to the default value (**CLEAR**).

Notes:

- *It is not the contact with the touch-key itself that triggers the corresponding action, but the cessation of the touch.*
- *If you switch the transmitter off and then immediately on again, you may find that the touch-keys have no effect. This is not a fault! Switch the transmitter off again, and wait a few seconds before switching it on once more.*

Short-Cuts

You can call up particular menus or options directly using the following button combinations:

- **CLEAR**
A brief simultaneous press of the ▲ ▼ or ◀ ▶ buttons of the right-hand touch-key resets an altered parameter value in the active input field to the default value.
- “**Servo display**”
A brief simultaneous press of the ◀ ▶ buttons of the left-hand touch-key switches from the transmitter’s base display, and from almost any menu position, to the “**Servo display**”, menu; see page 113.
- “**Telemetry**”
Press the central **ESC** button of the left-hand touch-key for about three seconds at the transmitter’s base display; see section starting on page 117.
- “**HIDDEN MODE**”
(language selection and contrast)
Simultaneously press the arrow buttons ▲ ▼ of the left-hand touch-key AND the central **SET** button of the right-hand touch-key; see next page.
- **Input lock**
Can be activated and disabled at the transmitter’s basic display by simultaneously holding the **ESC** and **SET** buttons pressed in for about two seconds.

HIDDEN MODE

Language selection and screen contrast

The “**HIDDEN MODE**” (VERSTECKTER MODUS) menu of the **mx-16** HoTT transmitter can be accessed from virtually any menu position by holding the arrow buttons ▲ ▼ of the left-hand touch-key and the **SET** button of the right-hand touch-key pressed in; after about three seconds this display appears:

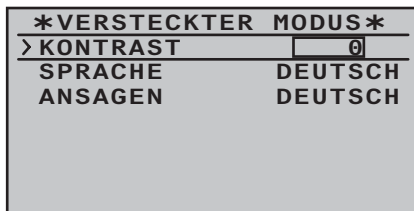

CONTRAST

In the “CONTRAST” (KONTRAST) line you can adjust the screen contrast to suit your preference by briefly pressing the central **SET** button of the right-hand touch-key, as described in full on page 114 / 115. With a second brief press of the **SET** or **ESC** button you return to the line select point.

In the ...

LANGUAGE

... (SPRACHE) line below it, which you can access by briefly pressing the arrow button ▼ of the left-hand or right-hand touch-key, you can select your preferred language.

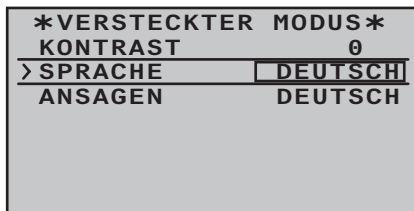

Activate the value field by pressing the central **SET** button of the right-hand touch-key:

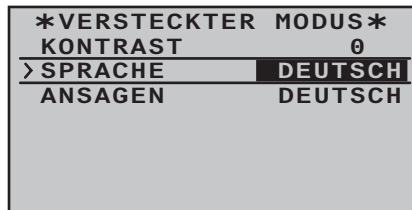

Now replace the default language “DEUTSCH” (German) with your preferred language using the arrow buttons of the right-hand touch-key. For example:

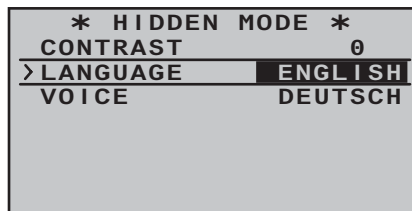

If you change the language, all the settings stored in the transmitter are retained in full. When this manual went to press, the following two languages were available:

- German
- English

The languages French, Italian and Spanish will be made available later on the Download page of the transmitter at www.graupner.de in the form of an update.

VOICE MESSAGES

As mentioned in the “Headphone socket” section on page 21, the signals associated with the Telemetry menu and voice messages can be generated via this socket, in addition to the transmitter’s audible signals. The default language for these messages is German.

These voice messages are collected in a voice package and stored in the transmitter’s internal memory, but they can be replaced by a voice package in another language at any time.

When this manual went to press, the following languages were available:

- German
- English

The languages French, Italian and Spanish will be made available later on the Download page of the transmitter at www.graupner.de in the form of additional voice files. The active voice package can be replaced using either the PC program which can be found on the transmitter’s Download page at www.graupner.de, or using an SD card, as described below.

Preparation

If you have not already done so, insert your SD or SDHC card in the transmitter, as described on page 22. When you switch the transmitter on, it immediately creates a “VoiceFile” folder on the memory card.

Remove the prepared memory card from the transmitter, and insert it in a suitable card reader. Connect this to your PC or laptop, and copy the voice package, typically “voice_gb.vdf”, into this folder; this is the file which you previously downloaded from the transmitter’s Download page. Remove the memory card from the card reader, and insert it in the transmitter once more. Switch the transmitter on with RF switched off:



Changing the language

Use the arrow buttons of the left or right-hand touch-key to move to the "VOICE" line:

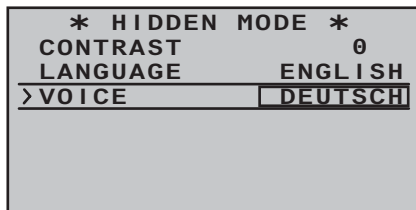

Activate voice output by pressing the central **SET** button of the right-hand touch-key:

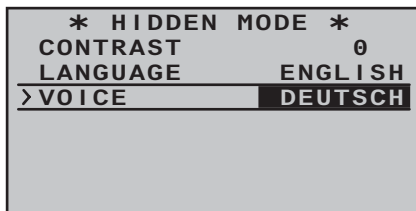

Now use the arrow buttons of the right-hand touch-key to replace the default language "DEUTSCH" (German) with the language of your choice. For example:

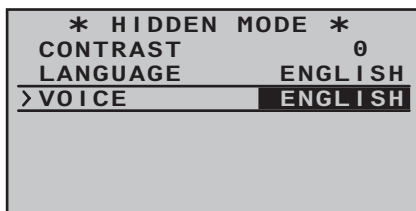

Confirm your selection by briefly pressing the central **SET** button of the right-hand touch-key again: the selected voice package is now loaded into the transmitter's memory:

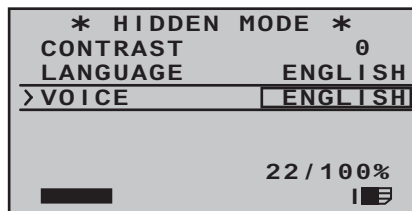

The loading process is finished when the progress bar at the bottom edge of the screen disappears:

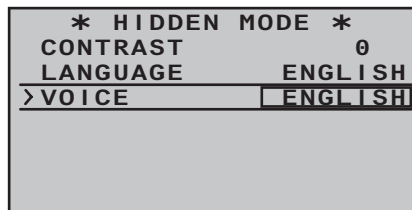

Finally switch the transmitter off to conclude the procedure.

All the settings stored in the transmitter are retained in full even after you have switched languages.

Notes:

- If the warning message ...

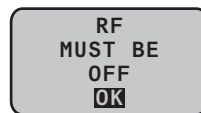

... appears, then the transmitter's RF section is still active. Switch this section off in the "RF module" line of the **"Basic settings"** menu, and repeat the procedure.

- If the warning ...



... appears, then there is no memory card in the card slot, or the card cannot be read.







- If the warning ...



... appears, then there is no suitable voice file on the SD card you have inserted.

Warnings

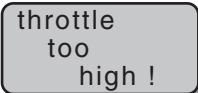
Warnings

	"Binding not present" No receiver is bound to the currently active model memory. A brief touch of the SET button takes you directly to the corresponding option.
	Do you want the RF signal to be "ON" or "OFF"?
	Battery must be charged Operating voltage too low
	Fail-Safe not yet set up
	No suitable voice files found on the memory card
	The throttle stick (or helicopter limiter) is set too far in the direction of full-throttle
	Request to switch off the RF section (voice files can only be loaded with the RF section switched off)



No bound receiver in range.

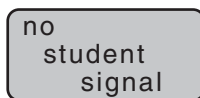

No connection between Teacher and Pupil transmitters



No SD or SDHC memory card in the card slot, or card cannot be read.



A "wireless Trainer connection" was used before the transmitter was last switched off; do you wish that connection to be continued (ACT), or switched OFF (INH)?

On-screen function fields

SEL, STO, SYM, ASY, /-, ⏏

The bottom line of the screen displays function fields which vary according to the menu selected.

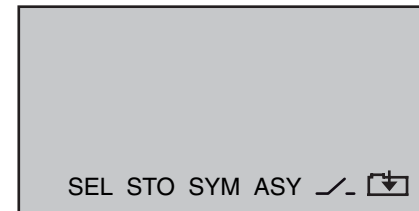

The function fields are activated by touching the **SET** button.

Function fields

- **SEL** select
- **STO** store (e.g. transmitter control position)
- **SYM** adjust values symmetrically
- **ASY** adjust values asymmetrically
- **/-** Switch symbol field (assigning switches of all kinds)
- **⏏** Switch to second page (next menu) within a menu

Position display

Rotary proportional controls CTRL 7 and 8

As soon as you operate one of the two rotary controls CTRL 7 + 8 on the centre console, a small symbol appears to the right of the two vertical position indicators:



At the same time the position display of the two central vertical bars switches for the duration of the actuation from the display of the current trim position to the current position of the rotary controls CTRL 7 + 8.

As you would expect, the left-hand bar represents the position of the left-hand rotary control CTRL 7, and the right-hand bar reflects the position of CTRL 8 (however, both horizontal bars continue to show the current position of the corresponding transmitter stick trim levers):

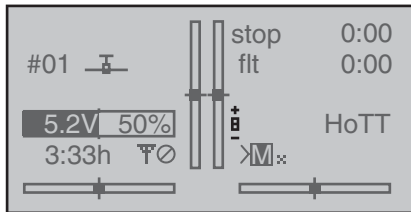

About two seconds after you cease operating one of the two rotary controls, the screen reverts to a display of the current position of the four trim levers for the two dual-axis stick units.

Input lock

To prevent programming errors, it is possible to lock the touch-keys, and with them access to all the set-up options, from the base display of the **mx-16** HoTT transmitter by touching the **ESC** and **SET** buttons for about two seconds. This is indicated by an inverted key symbol at the centre point of the trim bars:

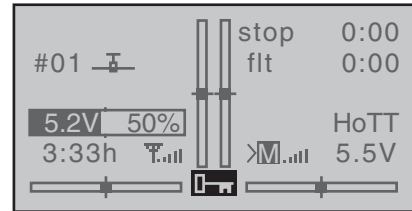

The lock is immediately active, but the control system remains ready for use.

Touching the **ESC** and **SET** buttons again for about two seconds disengages the lock: the next time you switch the transmitter on, the lock is also disengaged.

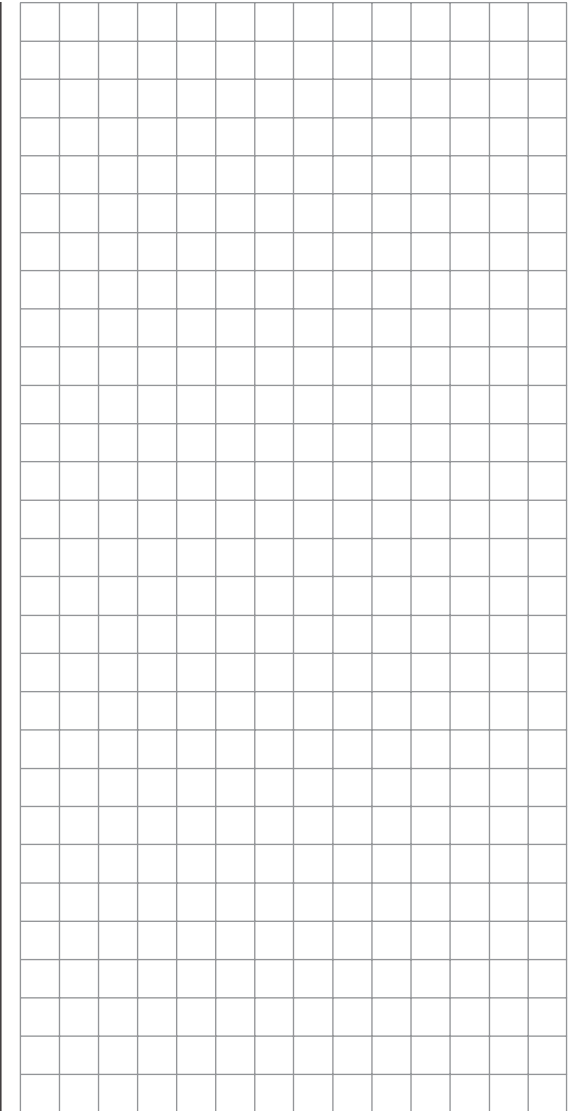

Using the transmitter for the first time

Preliminary notes regarding the mx-16 HoTT transmitter

For more information please visit our Internet site at www.graupner.de

Preliminary notes

In theory the *Graupner* HoTT system permits the simultaneous operation of more than 200 models.

However, in practice the mixed operation of different technical systems in the 2.4 GHz ISM band - as required by the approval regulations - reduces this number considerably. Generally, however, it will always be possible to operate even more models simultaneously on the 2.4 GHz band than on the 35 / 40 MHz frequency bands which we have used to date. However, the actual limiting factor - as it has always been - is likely to remain the size of the (air-) space available. The simple fact that no frequency control procedure is necessary - a great convenience in itself - equates to an enormous gain in safety, especially at flying sites where groups of pilots may be distributed over a large area, with nobody in overall control.

Battery charged?

When you take receipt of your transmitter, the battery will be in the discharged state, so you must first charge it as described on page 14. If you do not do this, the battery will soon fall below the pre-set threshold voltage, and you will see and hear a warning signal to remind you to recharge it.

battery
needs
charging

Switching the transmitter on

When you switch the transmitter on, the following display appears in the centre of the transmitter screen for about two seconds:

RF ON/OFF?
ON OFF

Within this period you can switch off the RF signal if required by moving the black field to the right using the ▲ or ► arrows of the right-hand touch-key; when you do this, ON should appear normal, and OFF in inverse form (black background).

RF ON/OFF?
ON OFF

You can now switch the RF module off by briefly pressing the central SET button of the right-hand touch-key. Until this point the central LED glowed blue, but it now changes to red, and at the same time the screen switches to the transmitter's base display:

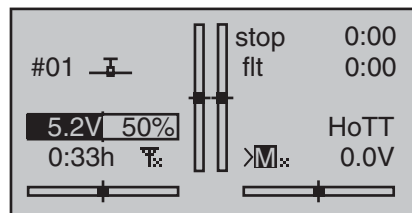

The >Mx symbol combination means that the currently active model memory is already "bound" to a *Graupner* HoTT receiver, but there is currently no connection with this receiver. (In our example we - of course - switched off the RF signal!)

In contrast, if you switch the transmitter on without switching off the RF signal, the central LED glows an intense blue, and the symbolic transmitter mast flashes. At the same time the transmitter emits an audible warning until a connection is made with the corresponding receiver. Once this connection exists, a field strength indicator appears instead of the "x" at the base of the symbolic aerial, for example >M...!!!, and the visual and audible warnings cease.

At the right of the same line a display in the same format appears when a telemetry connection is made, showing the strength of the telemetry signal picked up from the receiver (>M...!!!) together with the actual voltage of the receiver power supply.

However, if the symbol combination >M...!!! appears, and the central LED glows a constant red, the currently active model memory is not "bound" to any receiver.

Low-voltage warning

If the transmitter voltage falls below a particular value, a visual and audible low-voltage warning is generated. The default value is 4.7 V, but this can be varied in the "General Settings" menu (page 114).

Firmware update

Firmware updates for the transmitter are carried out at the owner's discretion using the five-pin mini-USB port on the back of the transmitter, in conjunction with a PC running Windows XP, Vista or 7. **Be sure to back up all stored model memories before carrying out the update, so that you can restore the data if necessary.** The latest software and information can be found in the Download section for the corresponding product at www.graupner.de.

Note:

Once you have registered your transmitter at <http://www.graupner.de/de/service/produktregistrierung> you will automatically be informed of new updates by e-mail as they become available.

Any standard commercial USB lead with a five-pin mini-USB plug at the transmitter end can be used to connect the transmitter to the PC; a typical example is that supplied with the interface, Order No. 7168.6.

Important notes:

- **The transmitter included in the set is prepared at the factory with the correct settings for most European countries (except France).**

If you wish to operate the RC system in France, you MUST first set the Country setting on the transmitter to “FRANCE” mode; see page 115. IT IS PROHIBITED to use the system IN FRANCE using the Universal / EUROPE mode!

- **You can operate up to eight servos using the mx-16 HoTT transmitter and the receiver supplied in the set, which is already bound to the transmitter.**

However, in the interest of maximum possible flexibility, control channels 5 ... 8 are not assigned to transmitter controls by default; this also helps to eliminate the danger of inadvertently using them incorrectly. For the same reason virtually all the mixers are inactive by default. For more details of this please refer to page 74 (fixed-wing model) or 76 (helicopter).

- **The basic procedure for programming a new model memory can be found on page 48, and in the programming examples starting on page 142.**
- **When switching on, binding or setting up the radio control system, please ensure at all times that the transmitter aerial is an adequate distance from the receiver aerials. If the transmitter aerial is too close to the receiver aerials, the receiver will be swamped, and the red LED on the receiver will begin to glow. At the same time the down-link channel will stop working. As a result the field strength bars on the transmitter screen are replaced by “x”, and the receiver battery voltage**

is displayed as 0.0 V. At the same time the radio control system switches to Fail-Safe mode. If this should happen, simply increase the distance between transmitter and receiver until the displays revert to “normal”.

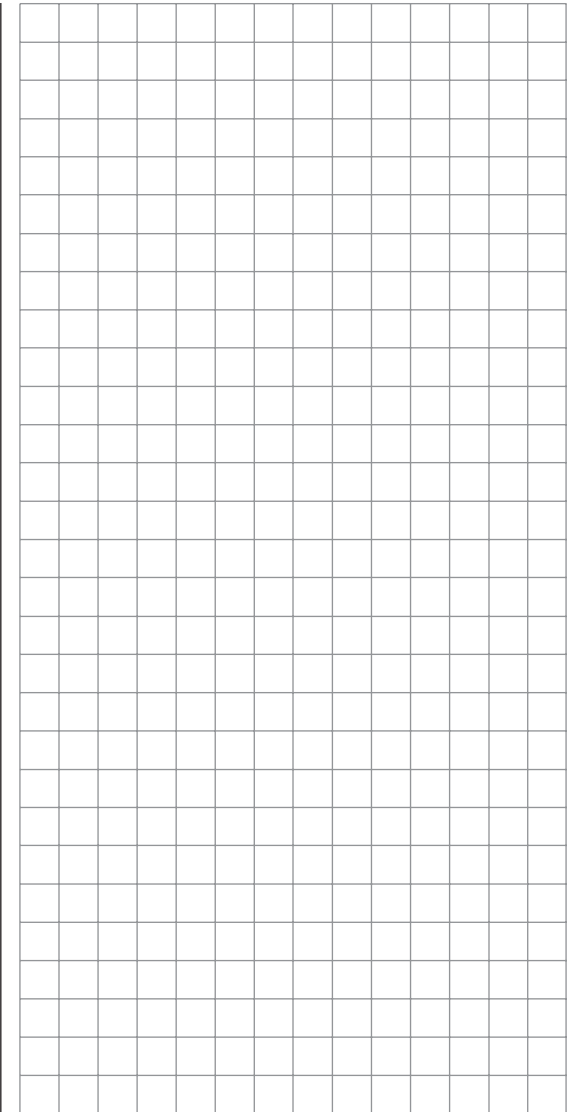

Using the receiver for the first time

Preliminary notes regarding the GR-16 receiver

For more information please visit the Internet at www.graupner.de.

Receiving system

The **mx-16** HoTT radio control set includes a GR-16 2.4 GHz bi-directional receiver which is suitable for connection to a maximum of eight servos.

If you switch a HoTT receiver on, and “its” transmitter is switched off or not within range, the red LED on the receiver lights up steadily for about one second, and then starts to flash slowly. This means that no connection with a *Graupner* HoTT transmitter exists (at this stage). When the connection is made, the green LED glows constantly, and the red LED goes out.

In order to create a connection, the *Graupner* HoTT receiver must first be “bound” to “its” model memory in “its” *Graupner* HoTT transmitter; this procedure is known as “binding”. However, binding is only necessary once for each receiver / model memory combination (see pages 61 or 70), and has been carried out at the factory for model memory 1 using the components supplied in the set. You therefore only need to carry out the “binding” process - as described later - with additional receivers, or if you switch to a different model memory. The procedure can also be repeated whenever you wish - for instance, if you change the transmitter.

Receiver voltage display

Once a telemetry connection exists, the actual voltage of the receiver power supply is displayed on the right-hand side of the transmitter screen.

Temperature warning

If the temperature of the receiver falls below a limit value set on the receiver (the default is -10°C), or exceeds the upper warning threshold, which is also set on the receiver (the default is $+70^{\circ}\text{C}$), the transmitter generates a warning in the form of steady beeps at intervals of

about one second.

Firmware update

Firmware updates for the receiver are carried out using the receiver’s telemetry socket in conjunction with a PC running Windows XP, Vista or 7. For this you require the separately available USB interface, No. **7168.6** and the adapter lead, Order No. **7168.6A**.

The latest software and information can be found in the Download area for the corresponding product at www.graupner.de.

Note:

Once you have registered your transmitter at <http://graupner.de/de/service/produktregistrierung> you will automatically be informed of new updates by e-mail as they become available.

Servo connections and polarity

The servo sockets of *Graupner* HoTT receivers are numbered. The connector system is polarised: look for the small chamfers when inserting the connectors, and on no account force the plugs into the sockets.

The sockets marked “1+B-” and “6+B-” are intended for the connection of the battery. It is also possible to connect the appropriate servos to both these sockets in parallel with the power supply by using a Y-lead, Order No. **3936.11**.

Do not connect the battery to these sockets with reversed polarity, as this is likely to ruin the receiver and any devices connected to it.

The power supply voltage is through-connected via all the numbered sockets. The function of each individual channel is determined by the transmitter you are using, rather than by the receiver. Example: the throttle servo

socket is defined by the radio control system, and may differ according to the make and type.

In the case of *Graupner* radio control systems the throttle function is assigned to channels 1 or 6, whereas it is allocated to channel 3 in the case of Futaba radio control systems, for example.

Concluding notes:

- *The much higher servo resolution of the HoTT system results in a substantially more direct response compared with previous technologies. Please take a little time to become accustomed to the finer control characteristics offered by the system!*
- *If you wish to use a speed controller with integral BEC* system in parallel with a separate receiver battery, in most cases (depending on the speed controller) the positive terminal (red wire) must be removed from the three-pin connector, as shown in the diagram. Be sure to read the appropriate notes in the instructions supplied with your speed controller before doing this.*

Carefully raise the central lug of the connector slightly (1), withdraw the red wire (2) and insulate the bare contact with tape to avoid possible short circuits (3).

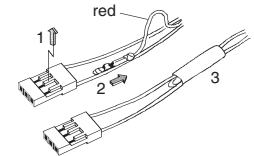

Observe the installation notes regarding the receiver, receiver aerial and servos, which you will find on page 34.

Reset

If you wish to carry out a receiver reset, locate the **SET** button on the top of the receiver and hold it in while you

* Battery Elimination Circuit

connect its power supply; release the button again. If the reset is carried out with the transmitter switched off, or if the receiver is not already bound, the receiver LED flashes red slowly after about two or three seconds; at this stage it is immediately possible to initiate a binding process at the transmitter. If the reset is carried out with an already bound receiver, if the transmitter is switched on, and if the associated model memory is active, then the LED lights up green after a short interval to indicate that your transmitter / receiving system is ready for use once more.

Please note the following:

Resetting the receiver resets ALL the settings stored in the receiver to the default settings, with the exception of the binding information! If you carry out a reset by mistake, this means that you will have to restore all the receiver settings entered using the Telemetry menu.

On the other hand, a deliberate RESET is particularly useful if you wish to “re-house” a receiver in a different model, as it represents an easy method of avoiding the transference of unsuitable settings.

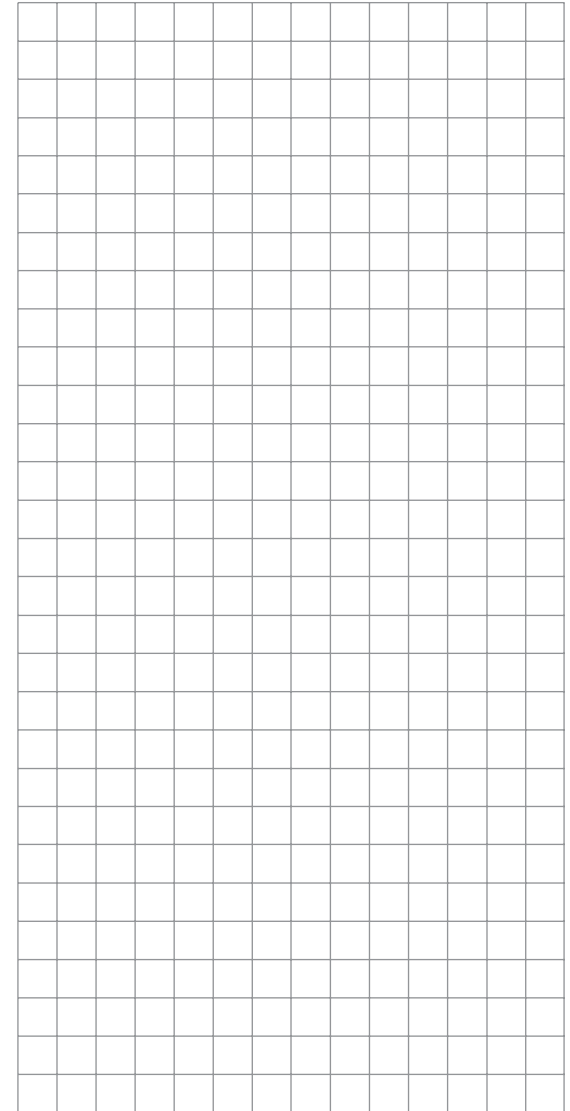

Installation Notes

Installing the receiver

Regardless of which *Graupner* receiving system you are using, the procedure is always the same:

Please note that the receiver aeri­als must be arranged at least 5 cm away from all large metal parts and leads which are not attached or connected directly to the receiver. This includes steel and carbon fibre components, servos, fuel pumps, cables of all sorts, etc. Ideally the receiver should be installed in an easily accessible position in the model, away from all other installed components. Under no circumstances run servo leads immediately adjacent to the receiver aeri­als, far less coil them round it!

Tests have shown that a vertical (upright) position of a single aerial produces the best results when long approaches are flown with a model. If the receiver features a diversity aerial system (two aeri­als), the second aerial should be deployed at an angle of 90° to the first.

The servo sockets of *Graupner* receivers are numbered. The socket marked “6+B” is intended for the battery, but an eighth servo can also be connected to it using a Y-lead, Order No. **3936.11**.

The power supply is through-connected using all the numbered receiver sockets; in principle the battery can be connected to any of the eight sockets.

The function of each individual channel is determined by the transmitter in use, rather than by the receiver. However, it is possible to alter the channel assignment (mapping) by changing the programming in the Telemetry menu. Nevertheless, we recommend that you carry out this process using the “Receiver output” option; see page 60 or 69.

The following section contains notes and helpful ideas on installing radio control components in the model:

1. Wrap the receiver in foam rubber at least 6 mm thick. Fix the foam round the receiver using rubber bands, to protect it from vibration, hard landings and crash damage.
2. All switches must be installed in a position where they will not be affected by exhaust gases or vibration. The switch toggle must be free to move over its full range of travel.
3. Always install servos using the vibration-damping grommets and tubular metal spacers supplied. The rubber grommets provide some degree of protection from mechanical shock and severe vibration. Don't over-tighten the servo retaining screws, as this will compress the grommets and thereby reduce the vibration protection they afford. The system offers good security and vibration protection for your servos, but only if the servo retaining screws are fitted and tightened properly. The drawing below shows how to install a servo correctly. The brass spacers should be pushed into the rubber grommets from the underside.

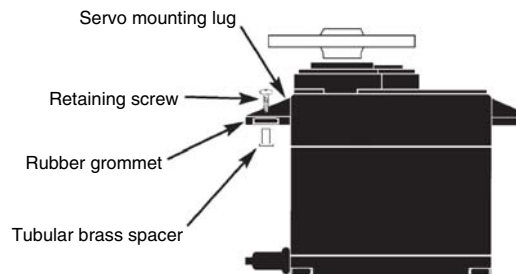

4. The servo output arms must be free to move over their full arc of travel. Ensure that no parts of the me-

chanical linkage can obstruct the servo's movement. The sequence in which the servos are connected to the receiver is dictated by the model type. Please see the socket assignments listed on pages 43 / 44 and 47. Be sure to read the additional safety notes on pages 3 ... 9.

If the receiver is ever switched on when the transmitter is off, the servos may carry out uncontrolled movements. You can avoid this by switching the system on in this order:

Always switch the transmitter on first, then the receiver.

When switching the system off:

Always switch the receiver off first, then the transmitter.

When programming the transmitter you must always ensure that any electric motors in the system cannot possibly burst into life accidentally, and that an I.C. engine fitted with an automatic starter cannot start unintentionally. In the interests of safety it is always best to disconnect the flight battery, or cut off the fuel supply.

Receiving system power supply

A reliable power supply is one of the basic essentials for reliable model control. Free-moving pushrods, a fully-charged battery, battery connecting leads of adequate cross-section, minimal transfer resistance at the connectors etc. all help to minimise energy consumption, but if you have attended to all this, and the receiver voltage displayed on the transmitter screen still collapses repeatedly, or is generally (too) low, then please note the following:

The first point to check is that your batteries are always fully charged at the start of each flying session. Check that contacts and switches are low in resistance. It is a good idea to measure the voltage drop over the installed switch harness under load, as even a new, heavy-duty switch can cause a voltage drop of up to 0.2 Volt. Ageing effects and oxidation of the contacts can increase this several times over. Constant vibration and movement at the contacts also “gnaws away” at the contacts, and tends to produce a creeping increase in transfer resistance.

It is also true that even small servos, such as the *Graupner/JR DS-281*, can draw currents of up to 0.75 Ampere when stalled (mechanically obstructed). Just four servos of this type in a “foamy” can therefore place a load of up to 3 Amps on the airborne power supply ...

For this reason you should always choose a receiver battery which constantly delivers an adequate voltage, i.e. which does not collapse under severe load. To “calculate” the necessary battery capacity we recommend as a starting point that you provide 350 mAh for each analogue servo, and at least 500 mAh for each digital servo.

For example, a 1400 mAh battery would represent an absolute minimum as the power supply for a receiving

system with a total of four analogue servos. When making your calculations, however, please bear the receiver in mind as well, as it draws a current of around 70 mA due to its bi-directional function.

Regardless of these considerations, it is generally advisable to connect the power supply to the receiver using two leads: lead “1” is connected to the 6+B receiver socket in the usual way, and lead “2” to the opposite socket, marked 1+B, at the other end of the receiver socket bank. For example, you could use a switch or voltage regulator with two power supply leads running to the receiver. You might install a Y-lead, Order No. **3936.11**, between lead and receiver, as shown in the diagram below, if you wish to use one or both of the receiver sockets to connect a servo, speed controller, etc. The dual connection at the switch or voltage regulator not only reduces the risk of a cable fracture, but also ensures a more even energy supply to the servos connected to the receiver.

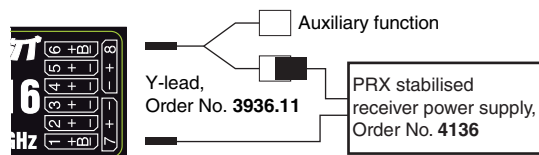

Four-cell Ni-MH battery packs

Traditional four-cell packs are a good choice for powering your *Graupner* HoTT receiving system, provided that you observe the conditions described above, i.e. you must ensure that the packs have adequate capacity and maintain their voltage well.

Five-cell NiMH battery packs

Five-cell batteries offer a wider margin of safety in terms of voltage compared with four-cell packs. However,

please note that not all servos available on the market can tolerate the voltage of a five-cell pack (in the long-term), especially when the battery is freshly charged. For example, many of these servos respond to the high voltage with a clearly audible “rumble”.

It is therefore important to check the specification of the servos you intend to use before you make the decision to use five-cell packs.

Two-cell Nanophosphate® (A123) batteries

Taking into account the current situation, these new cells are now regarded as the optimum choice for receiver packs. A123 cells can be fast-charged in conjunction with a suitable battery charger, and are protected by a metal case and therefore comparatively robust. It is also true that a much higher number of charge / discharge cycles is attributed to this cell type than, for example, to LiPo cells. The nominal voltage of 6.6 Volt of a two-cell Nanophosphate® pack presents no problems to *Graupner* HoTT receivers, nor to those servos, speed controllers, gyros, etc. which are expressly approved for use at these higher voltages. **Please note, however, that virtually all servos, speed controllers, gyros etc. sold in the past, and also most of those currently available, are only approved for use on an operating voltage in the range 4.8 to 6 Volt.** If you wish to connect these devices to the receiver, it is essential to use a stabilised regulated power supply, such as the PRX, Order No. **4136**; see Appendix. If you neglect this, there is a danger that the connected devices will quickly suffer permanent damage

Two-cell LiPo battery packs

For a given capacity LiPo batteries are a great deal lighter than the battery types described above, but they

are more susceptible to mechanical stress and damage due to their lack of a metal case. Moreover LiPo batteries only have a limited ability to be fast-charged, and generally do not survive such a high number of charge / discharge cycles as is claimed for other batteries, such as Nanophosphate® types. The comparatively high nominal voltage of 7.4 Volt of a two-cell LiPo pack presents no problems to *Graupner* HoTT receivers, nor to those servos, speed controllers, gyros, etc. which are expressly approved for use at these higher voltages. **Please note, however, that virtually all servos, speed controllers, gyros etc. sold in the past, and also most of those currently available, are only approved for use on an operating voltage in the range 4.8 to 6 Volt.** If you wish to connect these devices to the receiver, it is essential to use a stabilised regulated power supply, such as the PRX, Order No. **4136**; see Appendix. If you neglect this, there is a danger that the connected devices will quickly suffer permanent damage.

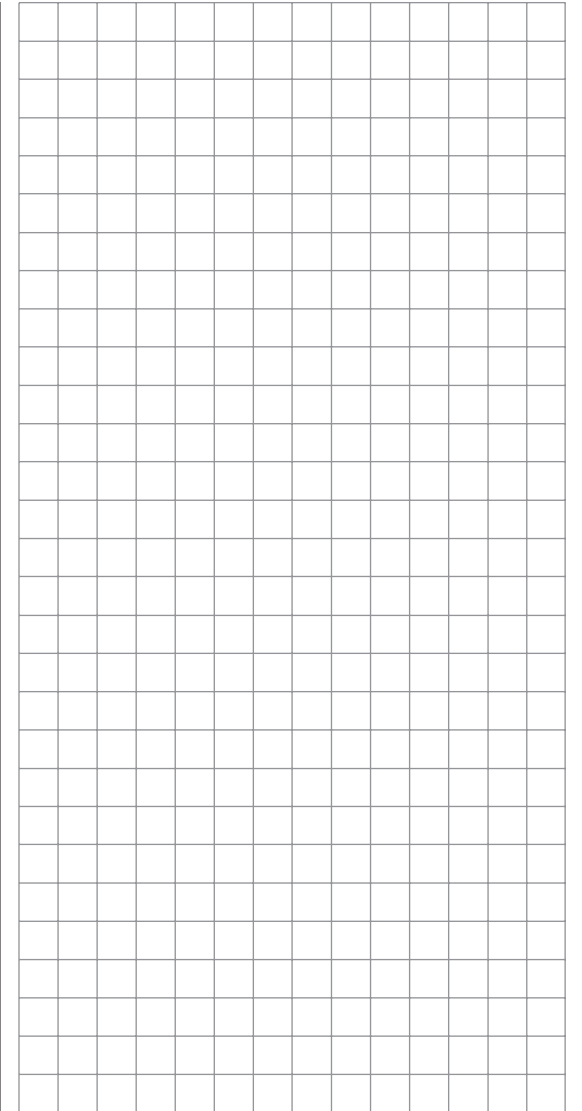

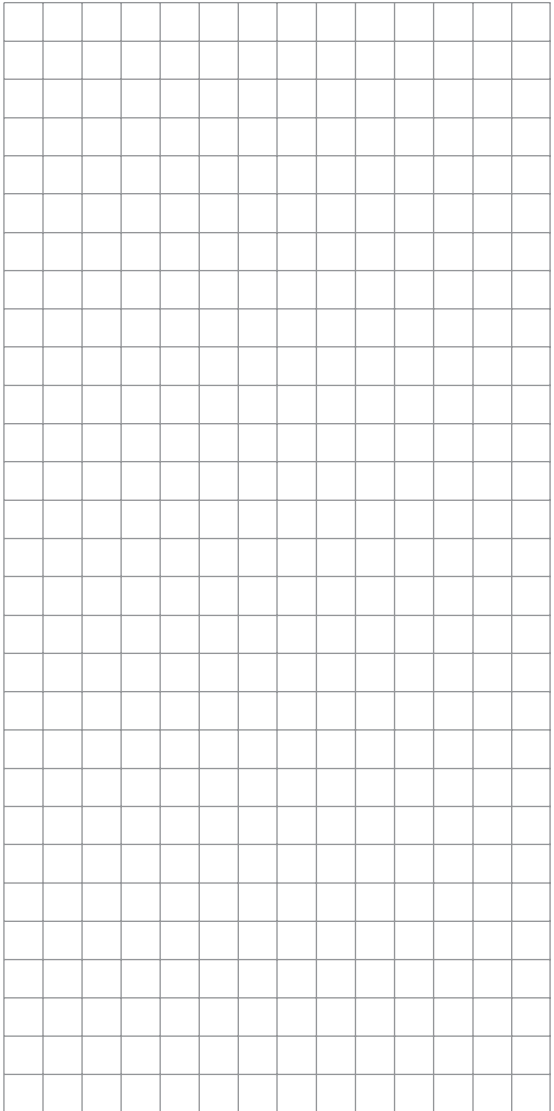
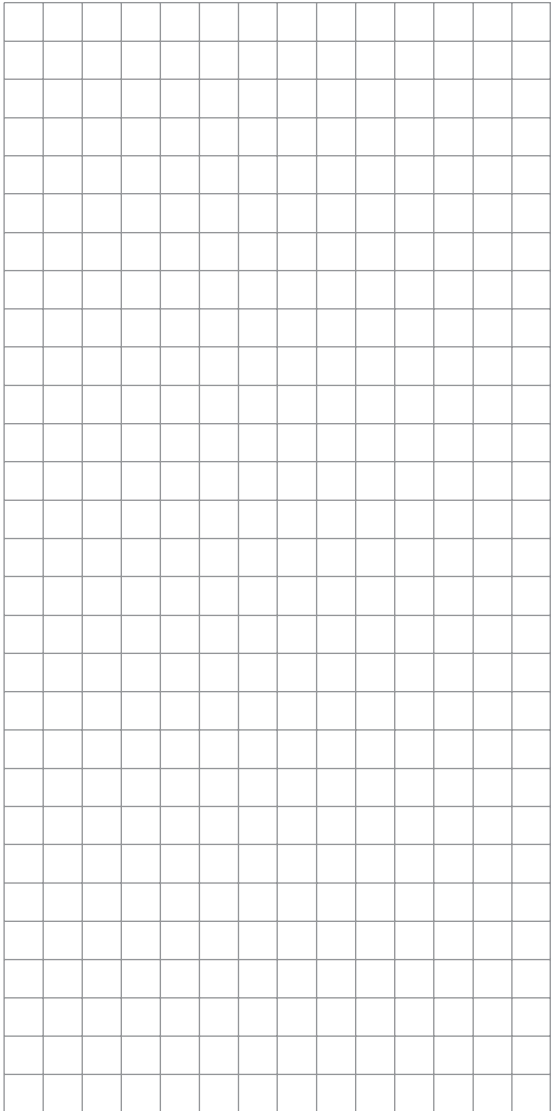
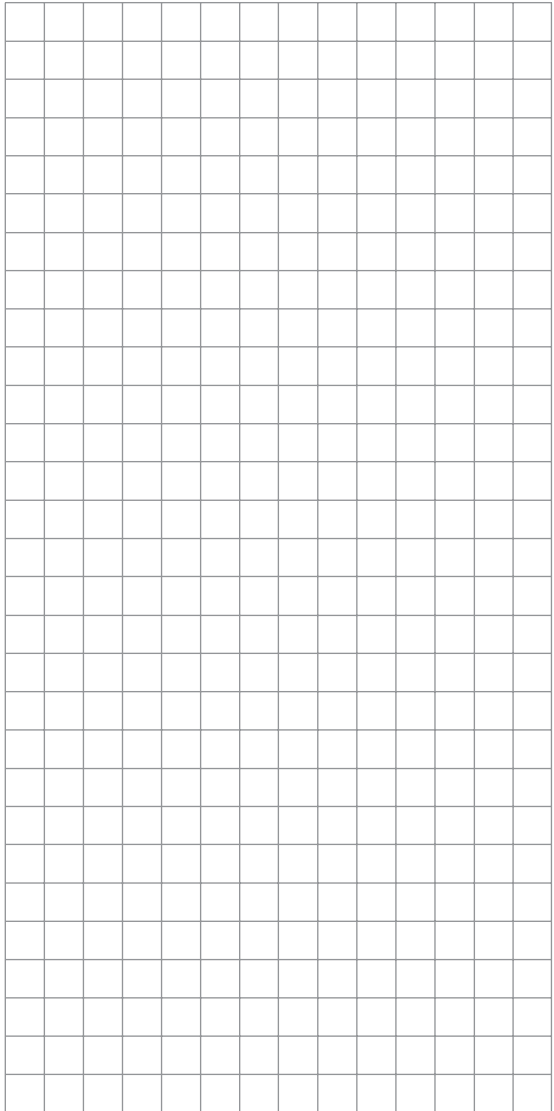

Definition of terms

Control functions, transmitter controls, function inputs, control channels, mixers, switches, control switches

To make it easier for you to understand the **mx-16** HoTT manual, the following section contains definitions of many terms which crop up again and again in the remainder of the text.

Control function

The term “control function” can be thought of as the signal generated for a particular function which needs to be controlled - initially independent of its subsequent progress through the transmitter. In the case of fixed-wing model aircraft the control functions include throttle, rudder and aileron, whereas collective pitch, roll and pitch-axis are typical of those used for helicopters. The signal of a control function may be assigned directly, or to several control channels simultaneously via mixers. A typical example of the latter is separate aileron servos, or pairs of roll-axis or pitch-axis servos in a model helicopter. The essential feature of a control function is its influence on the mechanical travel of the corresponding servo.

Transmitter control

The term “transmitter control” refers to the mechanical elements on the transmitter which are operated directly by the pilot. Their movements in turn generate corresponding movements in the servos, speed controllers etc. at the receiver end. The transmitter controls include the following:

- The two dual-axis stick units for the control functions 1 to 4; for both model types (“fixed-wing” and “helicopter”) these four functions can be interchanged in any way you wish using the “Mode” function, e.g. throttle left or right, without having to re-connect the servos. The dual-axis stick function for throttle (or airbrakes) is often referred to as the Ch 1 (Channel 1) control.
- The three rotary proportional controls CTRL 6, 7 + 8

- The switches SW 4/5 and 6/7, and CTRL 9 and 10
- The switches SW 1 ... 3, plus 8 and 9, if they have been assigned to a control channel in the “**Transmitter control settings**” menu.

When a proportional transmitter control is operated, the servo or servos follow the position of the control directly, whereas a switched channel provides just the two or three set servo positions.

Function input

This is an imaginary point on the signal path, and must not be considered the same as the point on the circuit board where the transmitter control is connected! The two menus “**Stick mode**” and “**Transmitter control settings**” affect the course of the signal “after” this point, and it is possible (and likely) that there will be differences between the number of the transmitter control (as stated above) and the number of the subsequent control channel.

Control channel

There is a point on the signal path where the signal contains all the control information required for a particular servo – this may be directly generated by a transmitter control or indirectly via a mixer – and from this point on we call the signal a “control channel”. This signal is only affected by any adjustments carried out in the “**Servo settings**” menu before leaving the transmitter via the RF module. Once picked up at the receiver, this signal may be modified by any settings made in the Telemetry menu before finally passing to the corresponding servo in the model.

Mixer

The transmitter’s software includes a wide range of mixer functions. Their purpose is to enable a control function to

affect multiple servos at the branching point of the mixer input, or alternatively to allow several control functions to affect one servo. For more information please refer to the numerous mixer functions as described in the section starting on page 88 of the manual.

Switch

The three standard switches SW 2, 3 and 8, the two three-position switches SW 4/5 and 6/7 and the two momentary buttons SW 1 and 9 can also be incorporated into the programming of the transmitter controls. However, all these switches are also generally intended for switching program options, e.g. starting and stopping timers, switching mixers on and off, transferring control in Trainer mode etc. Each physical switch function can be assigned to as many functions as you wish. Numerous examples are described in the manual.

Transmitter control switch

It is often desirable to switch a function on or off automatically at a particular position of another transmitter control, e.g. at a defined position of one of the dual-axis sticks. Typical examples are switching a stopwatch on and off to allow you to record the motor run time, extending spoilers automatically (and many others). The **mx-16** HoTT software includes a total of two (three - for helicopters) “control switches” of this type.

Two transmitter control switches are available for the Ch 1 stick in each model memory, both for fixed-wing model aircraft and helicopters. For helicopters a third is present in the form of the throttle limiter; see the right-hand side and page 67.

This manual includes a range of instructive examples which make programming as simple as child’s play. Please refer to the programming examples in the section starting on page 142.

Assigning switches and control switches

The basic procedure

At many points in the program there is the option of using a switch (SW 1 ... 9) or a control switch (G1 ... 3; see below) to operate a function, or to switch between settings, such as the DUAL RATE / EXPO function, flight phase programming, mixers and more. The **mx-16** HoTT allows you to assign several functions to a single switch.

The process of assigning switches is exactly the same in all the relevant menus, and we will explain the basic programming procedure at this point so that you can concentrate on the special features when reading the detailed menu descriptions.

A switch symbol appears in the bottom line of the screen at all programming points where switches can be assigned:



Move to the appropriate column using the arrow buttons of the left or right touch-key.

This is the procedure for assigning a switch:

1. Briefly press the **SET** button or the right-hand touch-key. The following message appears on the screen:

push desired switch
into position ON

2. Now simply move the switch you wish to use to the "ON" position, press the push-button, or move the Ch 1 stick from the "OFF" position in the direction of "ON". Please note: the so-called control switches assigned to this transmitter control (see right) carry out the task of an ON / OFF switch in software; the same applies to the throttle limiter (see page 79) which is available in the "Helicopter" model type. This completes the assignment process.

Changing the direction of switching:

If the switch turns out to work in the wrong direction, you can correct it as follows: move the switch to the desired OFF position, activate switch assignment once more and assign the switch again, this time with the switch direction you prefer.

Erasing a switch:

Activate the switch symbol as described under Point 2, then press the button combination ▲▼ or ◀▶ simultaneously, or press the right-hand touch-key (**CLEAR**) button briefly.

Transmitter control switches

Many functions are best controlled automatically by a particular (freely programmable) position of the Ch 1 transmitter stick (or the throttle limiter in the case of helicopters), rather than by a conventional physical switch.

Typical applications:

- *Automatically switching an on-board glowplug energizer on and off according to the throttle position of the Ch 1 stick ("G1" or "G2"). In this case the switch for the plug energizer is controlled by a mixer at the transmitter.*
- *Automatically switching a stopwatch on and off to record the pure "flight time" of a model helicopter; this is accomplished using the "G3" switch of the throttle limiter.*
- *Automatically switching the "AIL → RUD" mixer off when the airbrakes are extended, in order to keep the wings parallel with the ground when landing on a slope face, without the (usually coupled) rudder affecting the model's heading.*
- *Automatically extending landing flaps with coupled elevator trim adjustment on the landing approach, as*

soon as the throttle stick is reduced below the set threshold point.

- *Automatically switching a stopwatch on and off in order to time the run of an electric motor.*

For both model types the **mx-16** HoTT transmitter's software caters for these purposes with two "control switches" of this type; they can be assigned to the Ch 1 stick: "G1" is switched on at around -80% of full travel, while "G2" is switched on at around +80%. The Helicopter program also includes an extra control switch "G3" on the throttle limiter close to the 100% point; see page 79.

All these control switches can be included without restriction in the free programming of the switches, i.e. they can be assigned to a function instead of a physical switch. This means that you are able to assign one of the control switches G1 ... G2 (or G1 ... G3) instead of a physical switch at any point in the software where switches are assigned. All you have to do is move the Ch 1 stick or the throttle limiter control (by default the rotary proportional control CTRL 6) from the desired "OFF" position in the direction of "ON".

Digital trims

Description of function, and Ch 1 cut-off trim

Digital trims with visual and audible indicators

Both the dual-axis stick units are fitted with digital trim systems. When you give the trim lever a brief push (one “click”), the neutral position of the associated stick channel changes by one increment. If you hold the trim lever in one direction, the trim value changes continuously in the corresponding direction with increasing speed.

The degree of trim offset is also “audible”, as the pitch of the tone changes to reflect the setting. When you are flying a model, you can find the trim centre position easily without having to look at the screen: if you over-run the centre setting, the trim stays in the centre position for a moment.

The current trim values are automatically stored when you switch from one model memory to another. The digital trims are also stored separately for each flight phase within a model memory, with the exception of the “Ch 1” (Channel 1) trim, which is the throttle / airbrake trim on a fixed-wing model.

The Ch 1 trim includes another special function which makes it easy to re-locate the idle throttle setting of a glowplug motor.

However, since the trim functions described in these instructions only affect the “Motor off” direction, the trim display on the transmitter’s screen will vary according to your individual set stick mode, i.e. the “forward” or “back” throttle / collective pitch minimum position of the Ch 1 stick, and also according to “left stick” or “right stick” for throttle / collective pitch. The illustrations in these instructions always refer to “Throttle / Collective pitch right” for both model types, and to “Throttle back” for fixed-wing models and “Collective pitch forward” for model helicopters.

1. Fixed-wing models



The Ch 1 trim features a special cut-off trim which is designed for glowplug motors: you initially use the trim lever in the usual way to select a reliable idle setting for the motor.

If you now move the Ch 1 trim lever to its end-point in the direction of “motor cut-off”, pushing the lever in a single movement, a marker appears on the screen in the last position. You can now return to the idle setting for starting the motor simply by pushing the stick one click in the direction of “open throttle”.

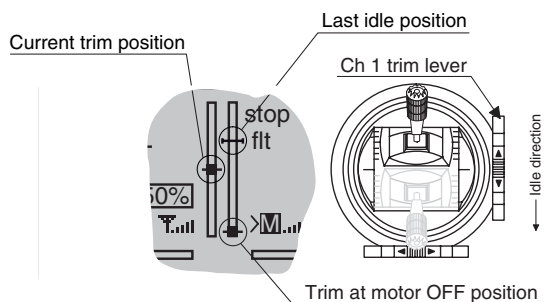

The cut-off trim feature is disabled if you enter “none” or “none / inv” in the “Motor at Ch 1” line within the “**Basic settings**” menu (page 56 / 57).

Note:

*Since this trim function is only effective in the “Motor off” direction, the above illustration will not apply if you change the direction of the Ch 1 stick for throttle minimum from “back” (which is reflected in the illustration above) to “forward” in the “Motor at Ch1” line of the “**Basic settings**” menu.*

2. Model helicopters



In helicopter mode the Ch 1 trim has another feature in addition to “cut-off trim”, as described under “Fixed-wing models” on the left; this time in conjunction with the “Throttle limit function” (see page 79): while the throttle limit slider is in the bottom half of its travel, i.e. in the “start-up range”, the Ch 1 trim lever acts as idle trim on the throttle limit, and the idle trim is displayed on the screen:

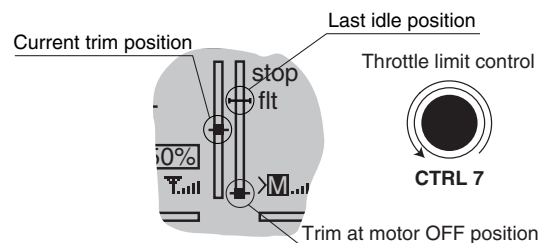

In contrast to a fixed-wing model aircraft, this display is suppressed if the throttle limit control is moved to the “right” half of its travel.

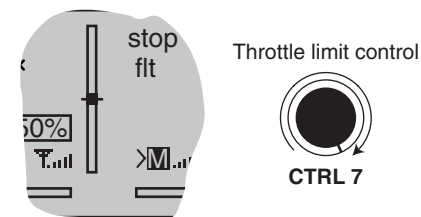

Note regarding helicopters:

The Ch 1 trim only affects the throttle servo and not the collective pitch servos; it also works evenly over the full stick travel. Please note that the helicopter throttle servo must be connected to receiver output 6 (see Receiver socket assignment, page 47).

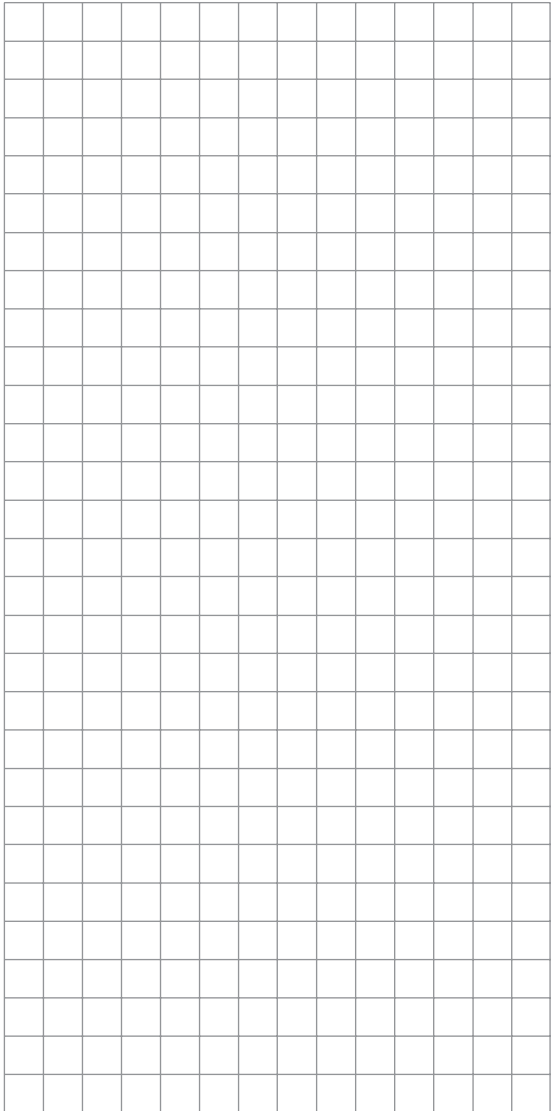
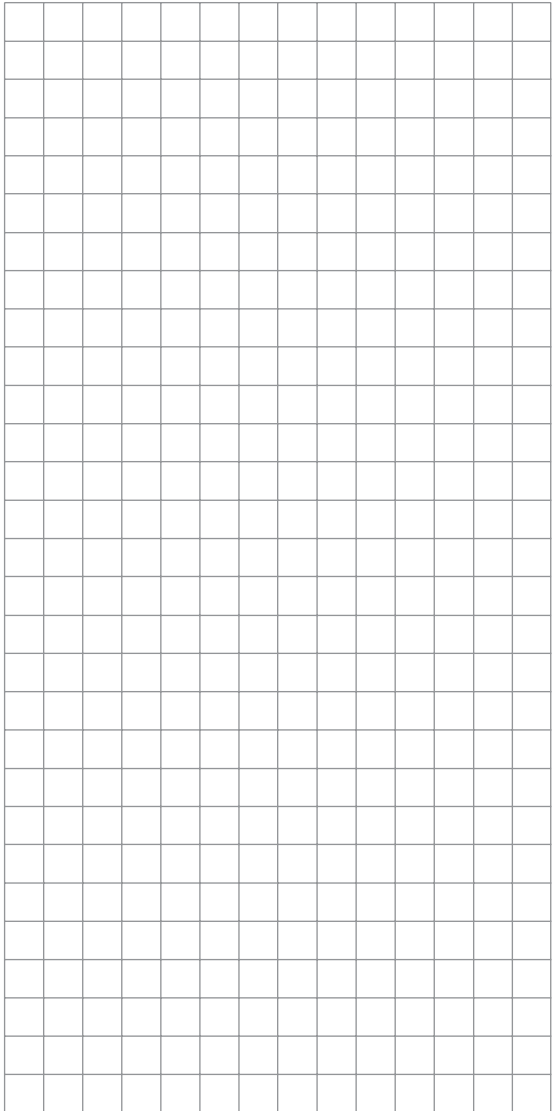
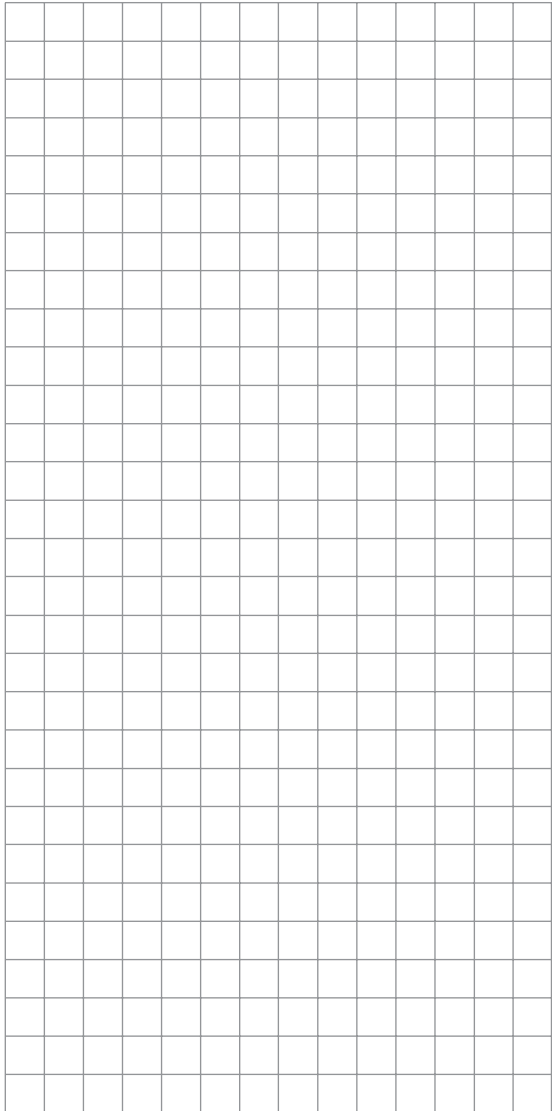

Fixed-wing model aircraft

This program provides convenient support for normal model aircraft with up to two aileron servos and two flap servos, V-tail models, flying wings and deltas with two elevon (aileron / elevator) servos and two flap servos.

The majority of power models and gliders belong to the “normal” tail type with one servo each for elevator, rudder, ailerons and throttle or electronic speed controller (airbrakes on a glider). There is also the special model type “2 EL Sv” which provides a means of connecting two elevator servos to channels 3 and 8 in parallel.

If your model features two separate aileron servos (and also in some cases two flap servos), the aileron travel of both pairs of control surfaces can be set up with differential movement in the “**Wing mixers**” menu, i.e. the down-travel can be set independently of the up-travel.

Finally the program caters for camber-changing flaps, which can be operated by any of the transmitter controls “CTRL 6 ... 10”. Alternatively a phase-specific trim is available for flaps, ailerons and elevator in the “**Phase trim**” menu.

If the model features a V-tail instead of a conventional

tail, you need to select the tail type “V-tail” in the “**Basic settings**” menu, as this automatically superimposes the elevator and rudder control functions in such a way that each tail panel can be actuated by a separate servo.

For deltas and flying wings it is easy to set up mixed elevons, i.e. the aileron and elevator functions can be carried out via common control surfaces at the trailing edge of the right and left wing. As standard the program contains the appropriate mixer functions for the two servos.

Up to four flight phases can be programmed in each of the twenty model memories.

The digital trim positions are stored separately for each flight phase, with the exception of the Ch 1 trim. The Ch 1 trim provides a simple means of re-locating the correct idle throttle setting.

Two timers are available at all times when flying. The screen also displays the transmitter operating time since the battery was last charged.

All the transmitter controls (CTRL) and switches (SW) can be assigned to virtually any of the inputs 5 ... 8 in the “**Transmitter control settings**” menu.

“Dual Rate” and “Exponential” can be programmed separately for aileron, rudder and elevator, giving two modes of control.

Depending on the model type you have selected, the “**Wing mixers**” menu presents you with up to twelve additional pre-defined mixers and coupling functions which you can simply select and set up when necessary, in addition to three free mixers:

1. Aileron differential (switchable)
2. Flap differential (switchable)
3. Aileron → rudder (switchable)
4. Aileron → flap (switchable)
5. Airbrake → elevator (switchable)
6. Airbrake → flap (switchable)
7. Airbrake → aileron (switchable)
8. Elevator → flap (switchable)
9. Elevator → aileron (switchable)
10. Flap → elevator (switchable)
11. Flap → aileron (switchable)
12. Differential reduction

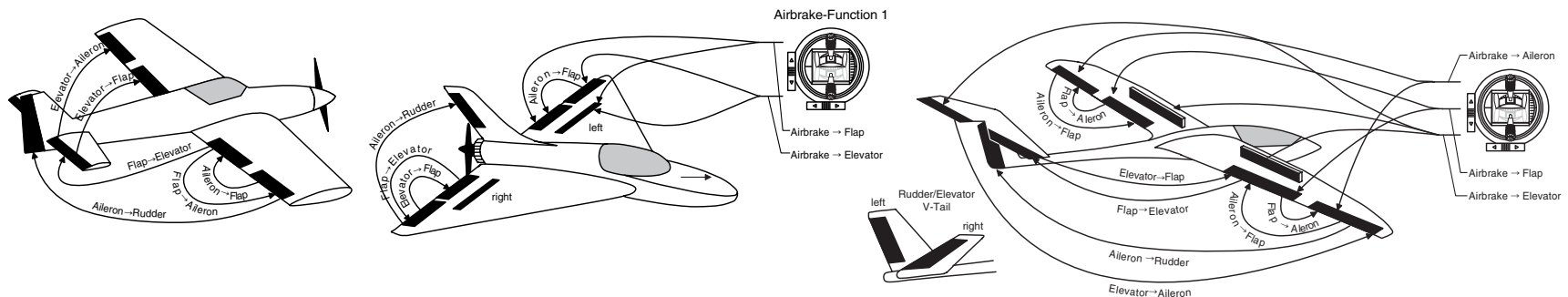

Receiver socket assignment for models with up to two ailerons and two flaps, plus “normal” tail type, V-tail, and two elevator servos (3 + 8)

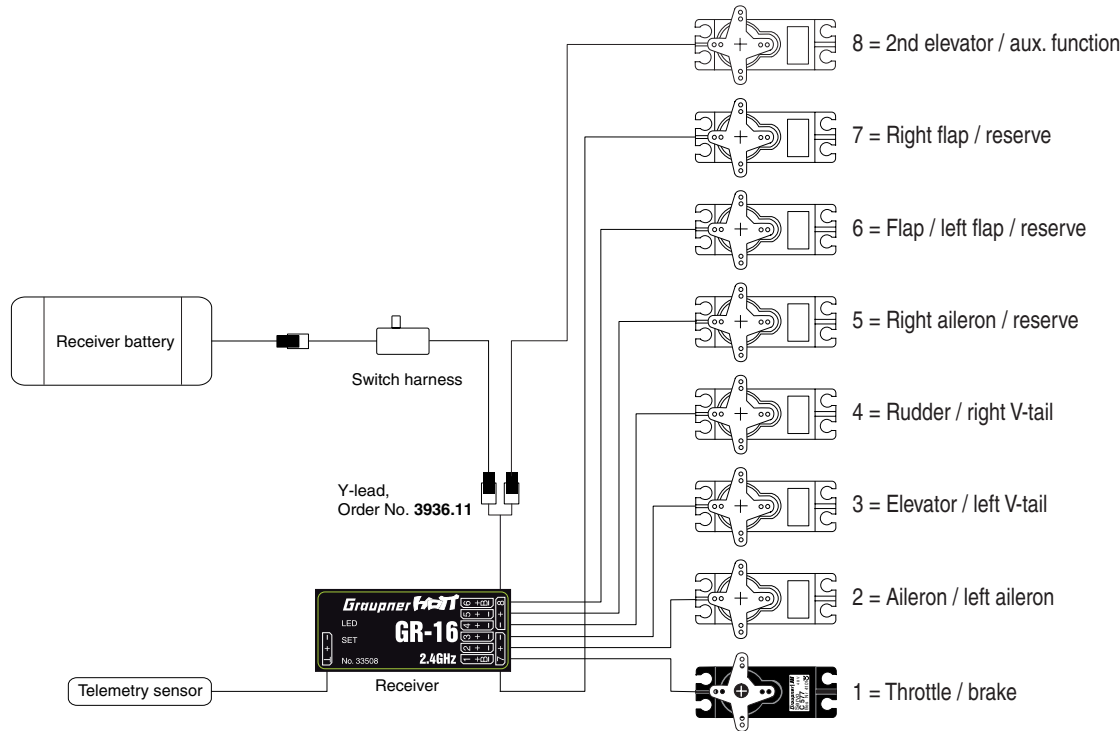

Installation notes

The servos MUST be connected to the receiver outputs in the following order:

Outputs not required are simply left vacant.

Please note the following points in particular:

- If you are using only one aileron servo, receiver output 5 (right aileron) is left unused; it can also be used for another purpose if you select “1 AIL” in the “**Basic settings**” menu.
- If you are using only one flap servo, receiver output 7 (right flap) MUST be left unused, assuming that you have selected “2 FL” in the “**Basic settings**” menu.

Please also read the information on the following pages.

Receiver socket assignment for models of the “Delta / Flying wing” type, with up to two flaps

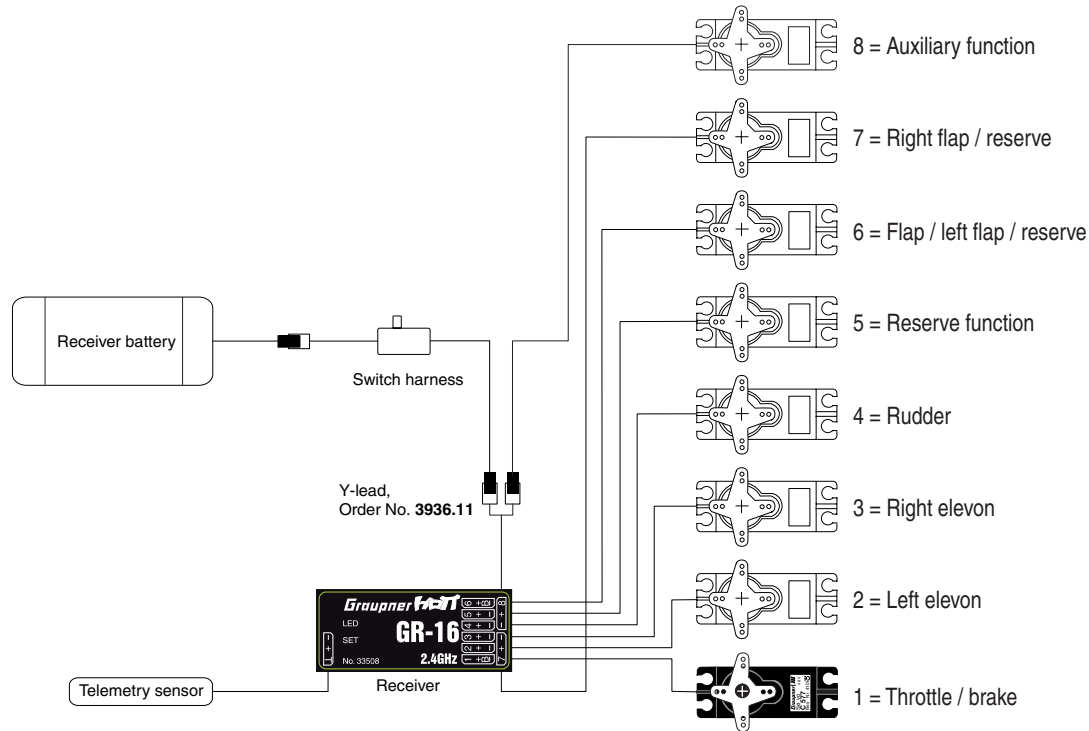

As there are several possible combinations of servo orientation and control surface linkage, you may find that the direction of rotation of one or more servos is incorrect. Use the following table to solve the problem.

Model type	Servo rotating in wrong direction	Remedy
V-tail	Rudder and elevator reversed	Reverse servos 3 + 4 in the “ servo set. ” menu
	Rudder correct, elevator reversed	Swap over servos 3 + 4 at the receiver
	Elevator correct, rudder reversed	Reverse servos 3 + 4 in the “ servo set. ” menu, AND swap over at the receiver
Delta, flying wing	Elevator and ailerons reversed	Reverse servos 2 + 3 in the “ servo set. ” menu
	Elevator correct, ailerons reversed	Reverse servos 2 + 3 in the “ servo set. ” menu, AND swap over at the receiver
	Ailerons correct, elevator reversed	Swap over servos 2 + 3 at the receiver

All menus which are relevant to fixed-wing models are marked with an “aeroplane” symbol in the “Program descriptions”:



This means that you can easily skip irrelevant menus when programming a fixed-wing model aircraft.

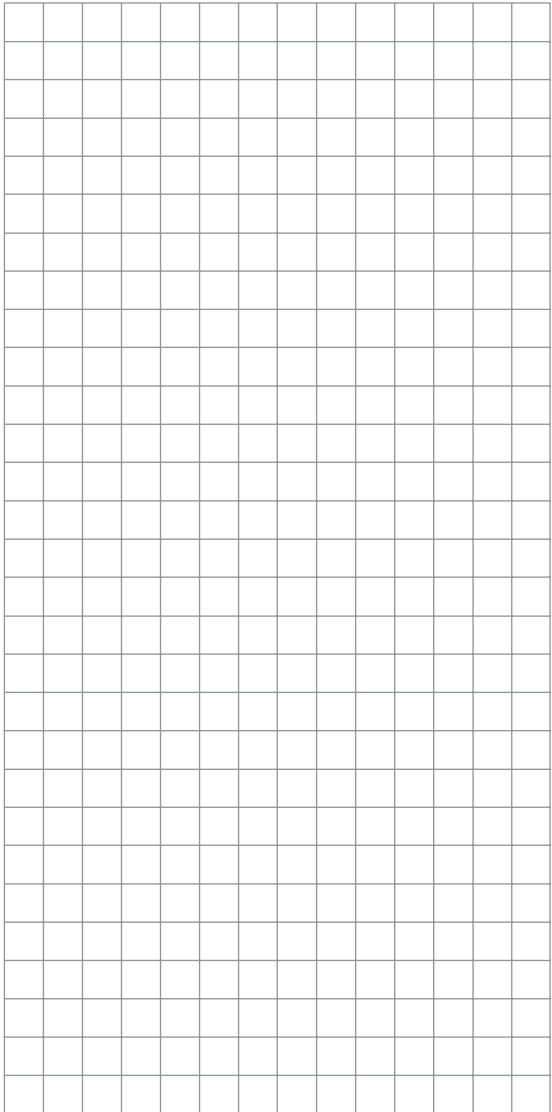
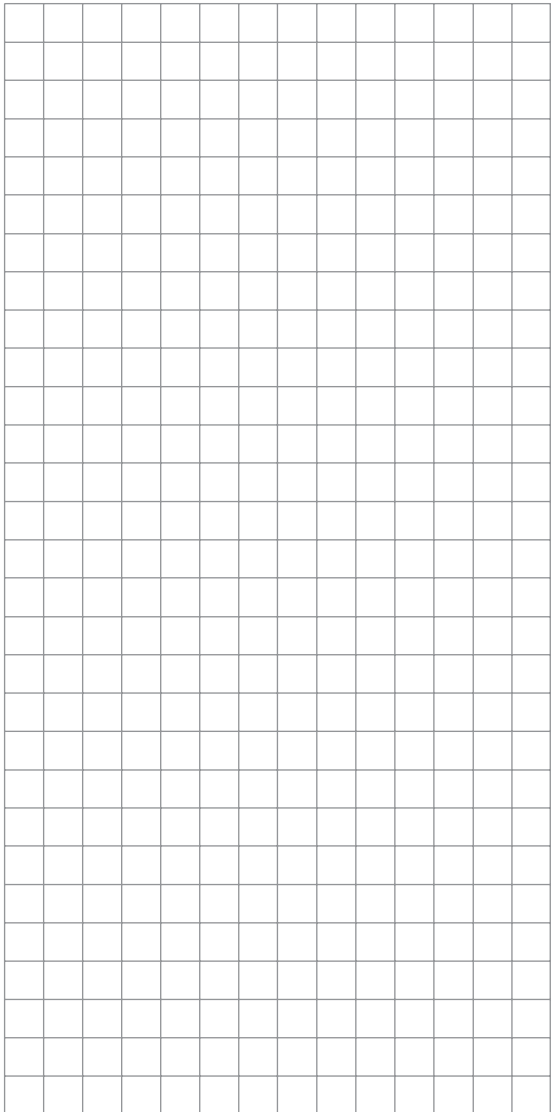
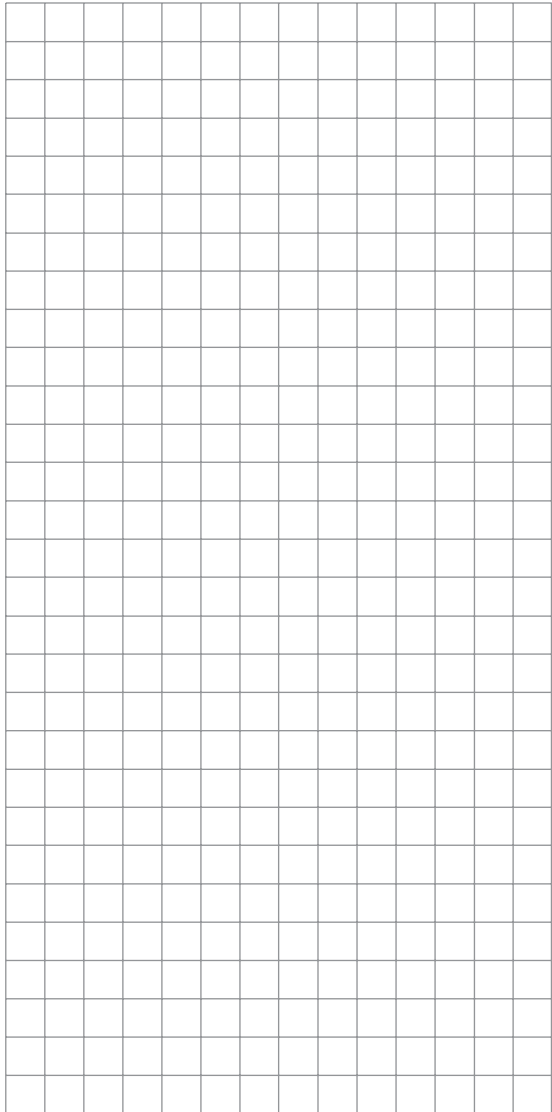

Model helicopters

The continued development of model helicopters and helicopter components, such as gyros, speed governors, rotor blades etc., has led to the current position where helicopters are capable of sophisticated 3-D aerobatics. In contrast, if you are a beginner to helicopter flying, you need a simple set-up so that you can quickly get started on the initial stages of hovering practice, and then gradually learn to exploit all the options provided by the **mx-16** HoTT.

The helicopter program of the **mx-16** HoTT can cope with all current model helicopters equipped with 1 ... 4 servos for collective pitch control, entirely regardless of whether they are powered by a fuel-driven or electric motor.

Each model memory can include three flight phases plus auto-rotation.

Two timers are constantly included in the basic screen display. At the same time the period which has elapsed since the last charge process is also displayed.

You can return to the correct idle position for the digital Ch 1 trim simply by pressing a button.

“Dual Rate” and “Exponential” are available for roll, pitch-axis and tail rotor; they can be coupled together, and programmed to provide two settings.

All the transmitter controls (CTRL) and switches (SW) can be assigned to inputs 5 ... 8 in virtually any order.

This is carried out in the “**Transmitter control settings**” menu.

In addition to three linear mixers, which can be assigned to any functions and can also be switched on and off, the “**Helicopter mixers**” menu provides five-point curves for the collective pitch, throttle and tail rotor mixers, variable separately for each flight phase; these provide non-linear mixer characteristics.

1. Collective pitch
2. Ch 1 → throttle
3. Ch 1 → tail rotor

Such advanced features are not needed by the beginner, who will initially simply set the hover point to coin-

cide with the centre point of the stick arc, and adjust the collective pitch travel as required.

Moreover the “**Heli mixers**” menu offers two additional set-up options in the lines “Gyro” and “Inp8”, plus a “**swashplate limiter**”.

The mixer inputs for collective pitch, roll and pitch-axis can then be adjusted in the “**Swashplate mixers**” menu. The throttle limit function in the “**Transmitter control settings**” menu provides an effective means of starting the motor in any flight phase. By default the proportional rotary control CTRL 7 is assigned to this input, and this control function determines the maximum throttle servo position, i.e. the trim lever controls the motor over the idle range. Only when this rotary knob is turned in the direction of full-throttle do the programmed throttle curves take effect. If you have set up the two timers, they also start recording the flight time automatically at this point. See page 79 for more information on this.

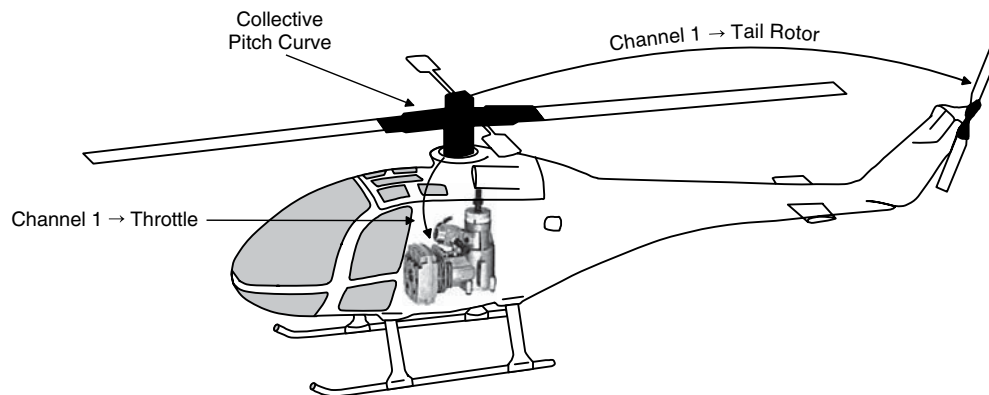

Note for modellers upgrading from earlier Graupner systems:

Compared with the previous receiver channel sequence, servo socket 1 (collective pitch servo) and servo socket 6 (throttle servo) have been interchanged. The servos **must** be connected to the receiver output sockets in the order shown at bottom right. Outputs not required are simply left vacant. For more information on the different types of swashplate, please refer to the **“Basic settings”**

menu described on page 64 / 65.

All menus which are relevant to model helicopters are marked with a “helicopter” symbol in the “Program descriptions”:



This means that you can easily skip irrelevant menus when programming a model helicopter.

Installation notes

The servos MUST be connected to the receiver outputs in the order shown on this page:

Outputs not required are simply left vacant.

Please note the additional information on the following pages.

Note:

To be able to exploit all the convenience and safety features of the throttle limiter (see page 79), the speed controller should be connected to receiver output “6”, and not to receiver output “8”, as shown in the drawing on the left. See page 97 for more details.

Receiver socket assignment for model helicopters

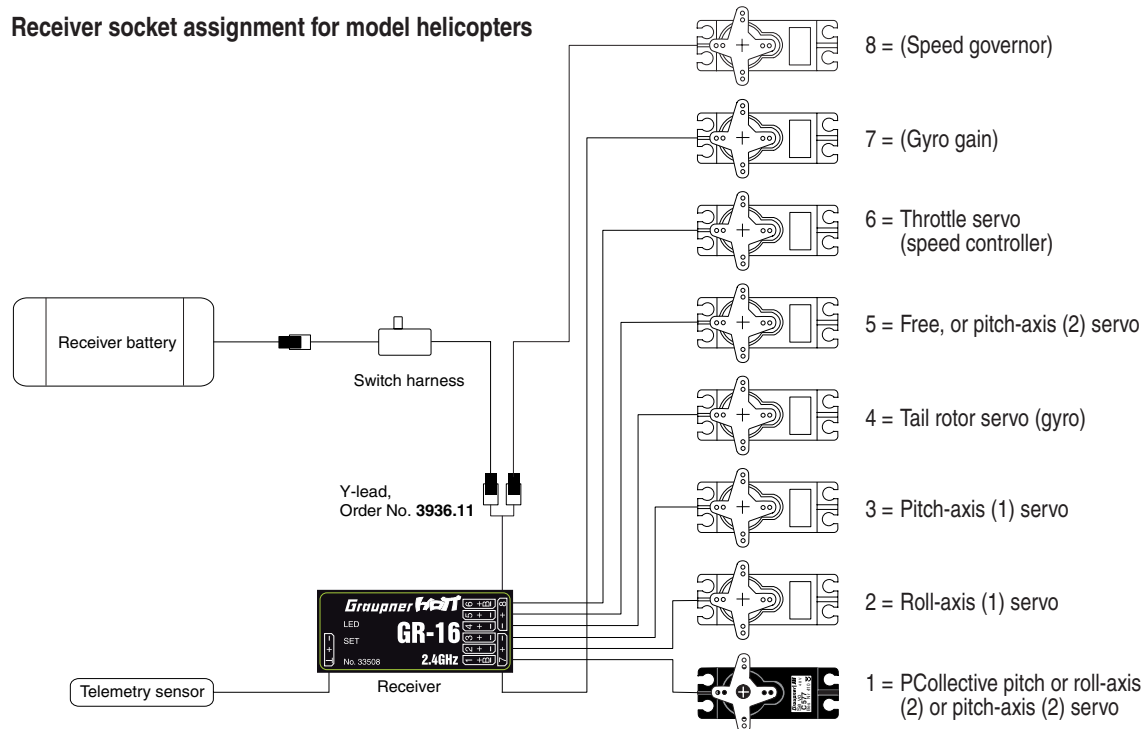



Detailed description of programming

Reserving a new memory

If you have already read through the manual to this point, you will undoubtedly have made your first attempt at programming the system already. Even so, it is important to describe each menu here in detail, to ensure that you have comprehensive instructions for each application you are likely to encounter.

In this section we start with setting up a “free” model memory prior to “programming” a new model:

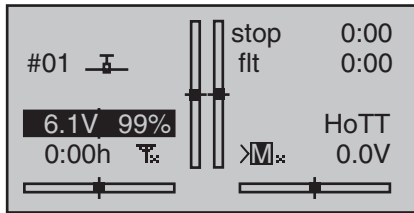

From the basic display press the central **SET** button of the right-hand touch-key to move to the “Multi-function list”. (You can return to the basic screen at any time by pressing the central **ESC** button of the left-hand touch-key.) By default the menu point “**Model memory**” is displayed inverse (black background) and is therefore active when you first call up the multi-function select menu after switching the transmitter on. If this is not the case, select the “**Model memory**” menu using the arrow buttons (▲▼, ◀▶) of the left or right-hand touch-key, then briefly press the central **SET** button of the right-hand touch-key:

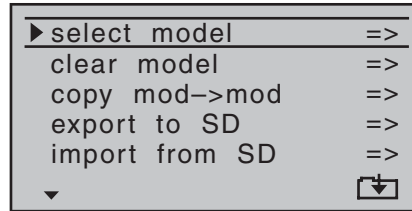
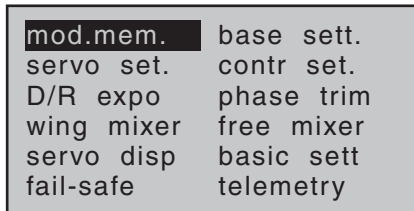

Now touch the central **SET** button of the right-hand touch-key once more to move on to the “select model” sub-menu.



In the transmitter’s default state the first model memory is already initialised with the “**Fixed-wing model**” model type, and the receiver supplied in the set is “bound” to it. This is indicated by the receiver code displayed at top right of the screen; in the example above this is R08. If, on the other hand, the model memory is “unbound”, you will see “---”.

The remainder of the model memories are not yet occupied, and are “unbound”; these are entitled “**free**”. If you want to set up a fixed-wing model, then you can immediately start the programming procedure after leaving the “select model” sub-menu and the “**Model memory**” menu by pressing the central **ESC** button of the left-hand touch-key each time ... alternatively you can select one of the free model memories using the left or right-hand touch-key ...



... and then briefly press the central **SET** button of the right-hand touch-key to confirm your choice.

After this you are invited to select the basic model type, i.e. either “Fixed-wing” or “Helicopter”:

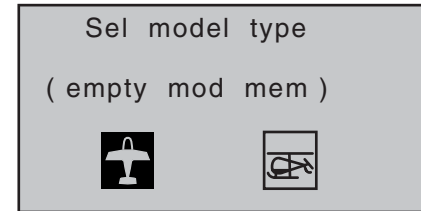

Use the ◀ or ▶ button of the left or right-hand touch-key to select the appropriate basic model type, then touch the central **SET** button of the right-hand touch-key to confirm your choice. The screen switches back to the basic display: your chosen model memory is now initialised with the selected basic model type, and the screen switches back to the basic display. The model memory is now reserved for that use.

However, if you wish to get started with a **helicopter**, then use the ▲ or ▼ button of the left or right-hand touch-key to select one of the model memories entitled “**free**”, and confirm your choice with a brief touch of the central **SET** button of the right-hand touch-key. You are now requested to define the basic model type, i.e. either “fixed-wing” or “helicopter”. Use the ▲ or ▼ button of the left or right touch-key to select the cor-

responding symbol, then again press the central **SET** button of the right-hand touch-key briefly in confirmation. This initialises the selected model type for the model memory you have just selected, and you can now start programming your model in this memory.

It is now only possible to change this memory to a different model type if you first erase the model memory ("**Model memory**" menu, page 52).

Notes:

- If you wish to erase the model memory which is currently active in the basic display, you will have to define one of the two model types "fixed-wing" or "helicopter" immediately after completing the erase procedure. You cannot avoid making this choice by switching the transmitter off. If you wish to remove a model memory which you inadvertently occupied, you can simply erase it from a different model memory.

However, if you erase a model memory which is not currently active, after the procedure you will see the memory marked as "**free**" under Model Select.

- After the selected model memory has been initialised with your preferred basic model type, the screen shifts to the newly reserved model memory. At the same time the following warning appears for a few seconds ...



... as an indication that this memory has not yet been bound to a receiver. With a brief touch of the central **SET** button of the right-hand touch-key you can move

directly to the corresponding option. For more detailed information on binding a receiver please refer to pages 61 and 70.

- Beneath the "BIND. n/v" warning described earlier you will also see the warning ...



... for a few seconds as an indication that no Fail-Safe settings have been entered yet. For more information on this please refer to page 116.

- If the warning ...

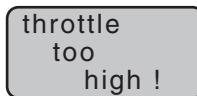

... appears on the screen, move the throttle stick (or the limiter - by default the rotary knob CTRL 6 - if setting up a helicopter) back to idle. This warning only appears in accordance with the settings you have entered in the "Motor at Ch1" or "Collective pitch min." section of the "**Basic settings**" menu, as described on pages 56 and 67. If you are setting up a non-powered fixed-wing model, enter "none" or "none/inv" at this point; this disables the throttle warning message, and makes available the "Brake → NN" mixers in the "**Wing mixers**" menu, which would otherwise be suppressed.

- If the transmitter's model memories are already occupied, then a pictogram of the selected model type appears in the appropriate model memory, followed by a blank line, or the model's name if a name has al-

* NN = Nomen Nominandum (name to be stated)

ready been entered in the "**Basic settings**" menu (pages 56 and 64), together with an indicator that the memory is bound to a receiver, if appropriate.

- If the battery voltage is too low, the software prevents you switching model memories in the interests of safety. In this case the screen displays this message:

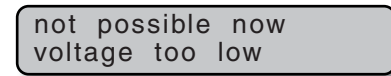

Basically there are now four different options for assigning the four control functions aileron, elevator, rudder and throttle / airbrakes (fixed-wing model), and roll, pitch-axis, tail rotor and throttle / collective pitch (model helicopter) to the two primary dual-axis sticks. Which of these options is adopted depends on the personal preference of the individual model pilot. This function is set in the "**Stick mode**" line for the currently active model memory in the "**Basic settings**" menu (page 56 or 64):

mod Name	<	>
▶ stick mode		1
motor on C1		no
CH8 delay		yes
tail type		normal
▼▲		

As mentioned earlier, for maximum flexibility the transmitter controls 5 ... 8 are by default not assigned to transmitter controls, and can be assigned to any channels you like; this also helps to avoid accidental mishandling.

This means that in the default state of the equipment only those servos connected to receiver outputs 1 ... 4 can usually be controlled by the two dual-axis sticks, whereas servos connected to sockets 5 ...

max. 8 remain steadfastly at their centre position. If you set up a new model helicopter, servo 6 may also respond to some extent to the controls - depending on the position of the throttle limiter CTRL 6. For both model types this situation only changes once you have carried out the appropriate assignments in the **“Transmitter control settings”** menu.

If you wish to use a newly initialised model memory, then this **MUST** first be “bound” to a (further) receiver before any servos connected to the receiver can be controlled from the transmitter. For more information on this please refer to the “Binding” section on pages 61 and 70. You will find a description of the basic steps for programming a fixed-wing model aircraft in the Programming Examples section starting on page 142; for model helicopters the equivalent section starts on page 164. The following menu descriptions are arranged in the order that they are listed in the individual menus in the multi-function list.

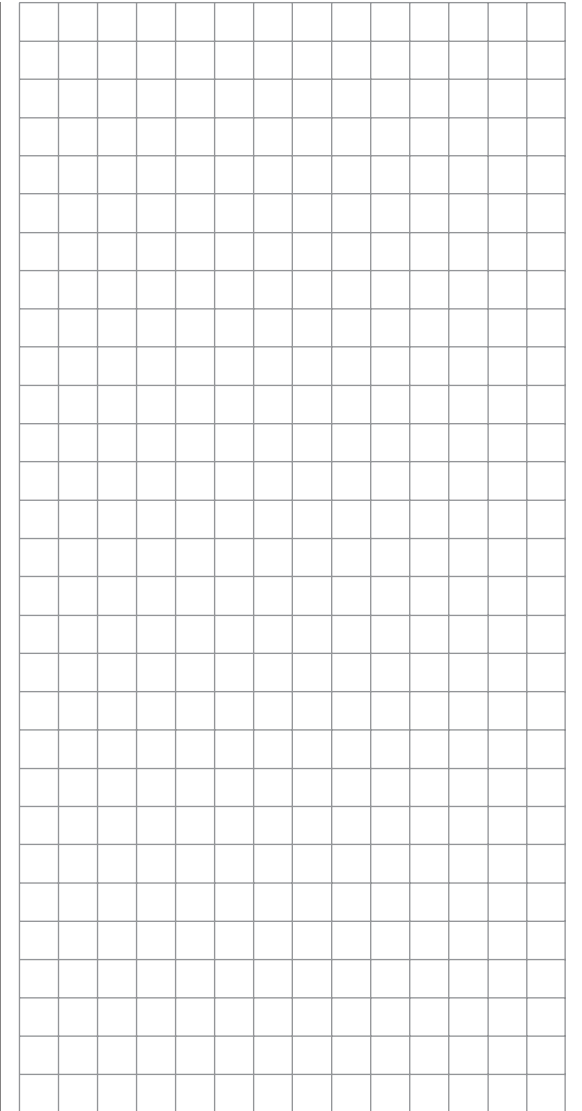

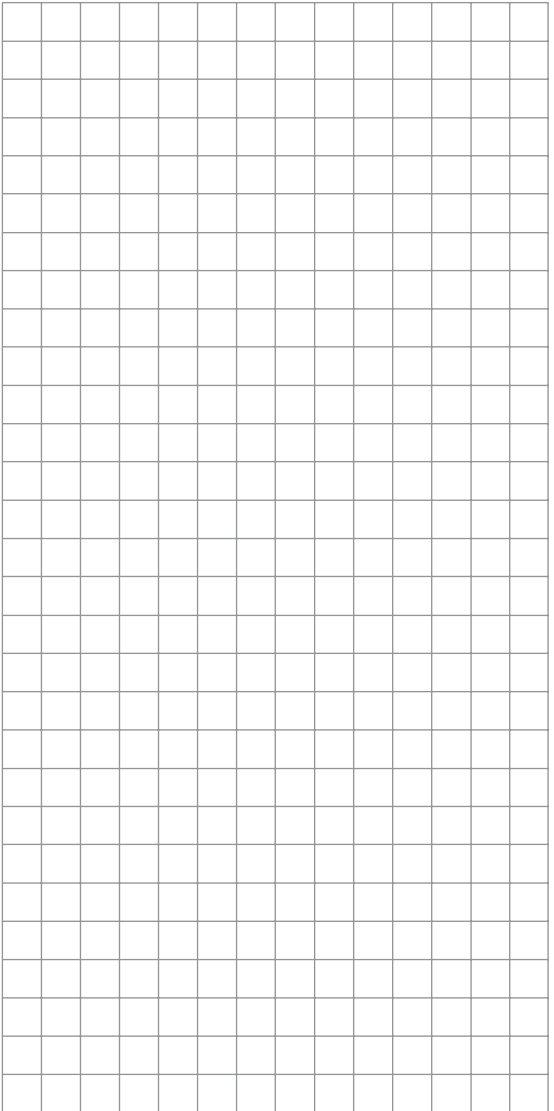
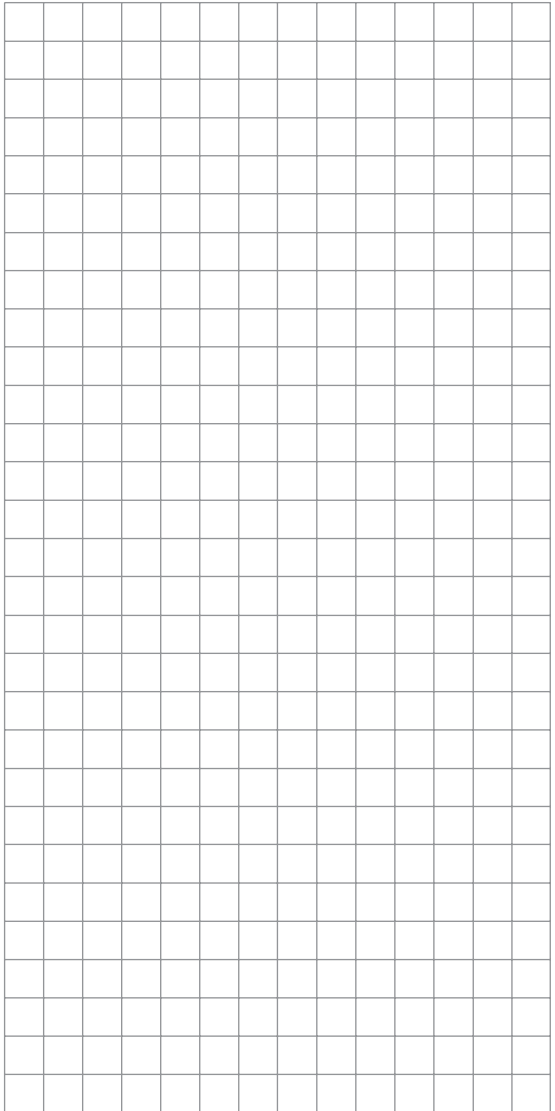
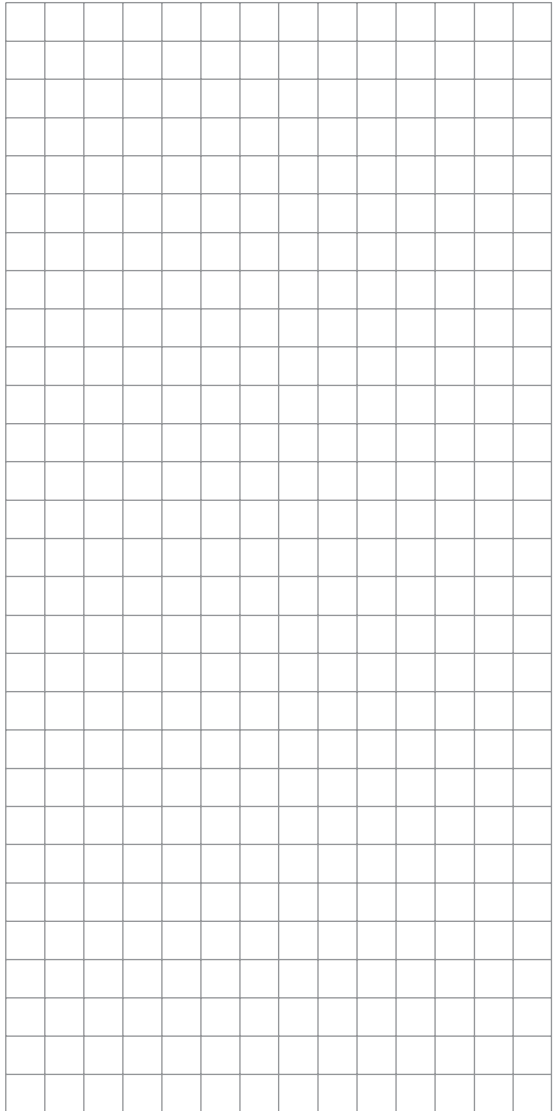



Model memories

Calling up a model, erasing a model, copying model → model

The section on pages 24 and 25 explains the basic method of using the buttons, while the previous two double-pages explains how to move to the Multi-function list and reserve a new model memory. At this point we wish to start with the “normal” description of the individual menu points in the sequence in which they occur on the transmitter itself. For this reason we start with the menu ...

Model memory

mod.mem.	base sett.
servo set.	contr set.
D/R expo	phase trim
wing mixer	free mixer
servo disp	basic sett
fail-safe	telemetry

The transmitter can store up to twenty complete sets of model data, including the digital trim values set by the four trim levers. The trims are automatically stored, which means that the settings you have carefully established through test-flying are never lost when you swap models. A pictogram of the selected model type, and - if you have entered a model name in the “Basic settings” menu (pages 56 and 64) - the name appears in all three sub-menus of the “Model memory” menu following the model number.

If necessary, use the arrow buttons of the left or right-hand touch-key to select the “Model memory” menu, then briefly touch the **SET** button of the right-hand touch-key:

select model

▶ select model	=>
clear model	=>
copy mod→mod	=>
export to SD	=>
import from SD	=>

If you now briefly press the **SET** button again, you move to the “Call up model” sub-menu:

01	GRAUBELE	R08
02	ULTIMATE	R08
03	STARLET	R08
04	BELL47G	---
05	**free**	
06	**free**	

Now use the arrow buttons ▲▼ of the left or right-hand touch-key to select from the list the model memory you wish to use, and confirm your selection by pressing the **SET** button. Pressing **ESC** takes you back to the previous menu page without switching models.

Notes:

- If the warning message “Throttle too high” appears when you switch models, the throttle or collective pitch stick (Ch 1), or the throttle limiter, is positioned too far towards full-throttle.
- If the battery voltage is too low, it may not be possible to switch model memories for safety reasons. In this case the screen displays the following message:

not possible now
voltage too low

clear model

select model	=>
▶ clear model	=>
copy mod→mod	=>
export to SD	=>
import from SD	=>

Use the arrow buttons ▲▼ of the left or right-hand touch-key to select the “clear model” sub-menu, then touch the **SET** button.

Select the model to be erased using the arrow buttons ▲▼ of the left or right-hand touch-key, ...

model to be cleared:		
01	GRAUBELE	R08
02	ULTIMATE	R08
03	STARLET	R08
04	BELL47G	---

... then touch the **SET** button again; the program responds with the security query:

model	
01	GRAUBELE
to be erased ?	
NO	YES

If you answer **NO**, the process is interrupted, and you are returned to the previous screen page. If you answer **YES** with the ▶ button of the left or right-hand touch-key and confirm your choice with the **SET** button, then the selected model memory is erased.

Caution:

The erasure process is irrevocable. All data in the selected model memory is reset to the factory default settings.

Note:

If you wish to erase the currently active model memory in the basic display, you will be required to define the model type "Helicopter" or "Fixed-wing" immediately. However, if you erase a non-active model memory, then the message "**free**" appears in the Model select menu.

copy model → model

Use the arrow buttons ▲ ▼ of the left or right-hand touch-key to select the "copy model → model" sub-menu, then touch the **SET** button.

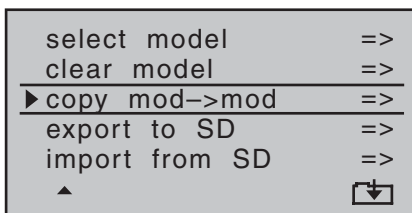

Select the model to be copied using the arrow buttons ▲ ▼ of the left or right-hand touch-key ...

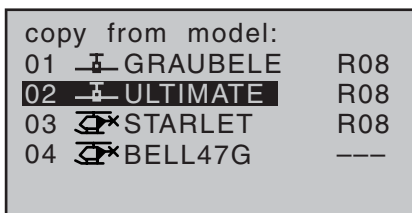

... then briefly press the **SET** button of the right-hand touch-key in the "Copy to model" window. You can now

select the target memory using the arrow buttons ▲ ▼ of the left or right-hand touch-key, and confirm your choice with **SET**. Alternatively you can interrupt the process with **ESC**. It is possible to overwrite a model memory which already contains model data.

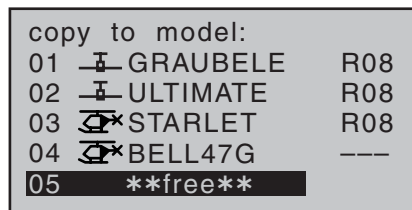

When you confirm the selected model memory by touching the **SET** button, the security query appears:

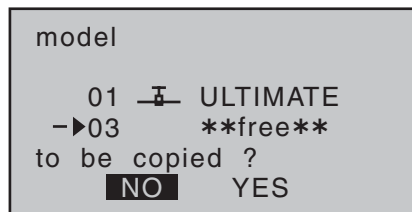

Selecting **NO** interrupts the process, and returns you to the previous page. If you select **YES** with the ► button, and confirm your choice by touching the **SET** button, then the selected model is copied into the chosen target model memory.

Note:

When you copy a model memory, the binding data is copied together with the model data, so that a receiving system bound to the original model memory can also be operated with the copy of the memory, i.e. it does not require another binding process.

Export to SD

Use the arrow buttons ▲ ▼ of the left or right-hand touch-key to select the "Export to SD" sub-menu, then touch the **SET** button.

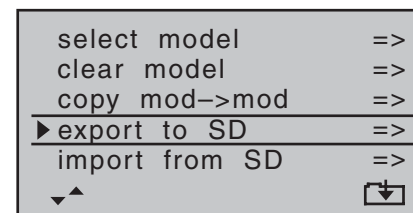

Use the arrow buttons ▲ ▼ of the left or right-hand touch-key to select the model to be exported:

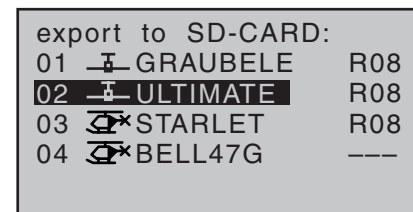

When you confirm the selected model memory with a brief press of the **SET** button, this security query appears:

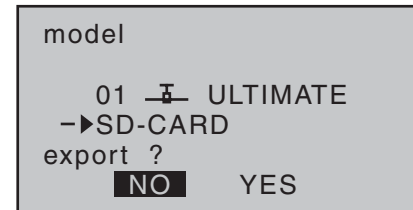

You can interrupt the process with **NO**; if you do this, you are returned to the starting screen. However, if you select **YES** with the ► button, and confirm your choice by touching the **SET** button, then the selected model is

copied to the SD card.

Notes:

- If the warning ...



... appears instead of a model selection, there is no SD card in the card slot; see page 22.

- When you copy a model memory, the binding data is copied along with the model data, so that the receiving system associated with the original model memory can also be operated using the SAME transmitter and the copied memory without repeating the binding procedure.
- An exported fixed-wing model is stored on the memory card under \Models\mx-16 with the format "aModelname.mdl" and a model helicopter with the format "hModelname.mdl". However, if you export a "nameless" model, then you will find its data stored on the memory card under "a-" and "hNoName.mdl".
- Some of the special characters used in certain model names cannot be accepted due to specific limitations of the FAT or FAT32 file system used by memory cards. During the copy process they are replaced by a tilde (~) character.
- If the memory card already contains a model file of the same name, it will be overwritten without warning.

Import from SD

Use the arrow buttons ▲▼ of the left or right-hand touch-key to select the "Import from SD" sub-menu, then briefly press the **SET** button.

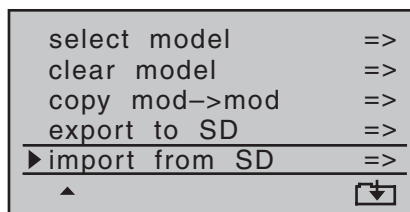

Use the arrow buttons ▲▼ of the left or right-hand touch-key to select the model to be imported from the SD memory card:

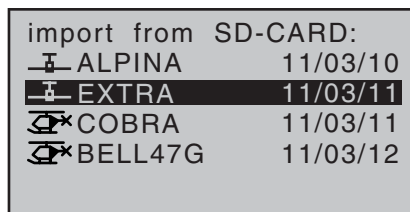

When you do this, and briefly press the **SET** button of the right-hand touch-key again, an "Import to model." window is displayed. Use the arrow buttons ▲▼ of the left or right-hand touch-key to select the target memory, confirm your choice with **SET**, or press **ESC** to interrupt the process. An occupied memory can be overwritten:

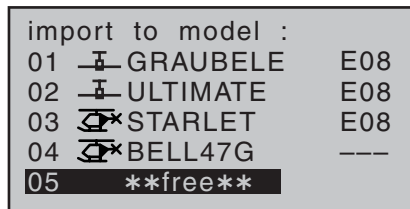

When you confirm the selected model memory by touching the **SET** button, this security query is displayed:

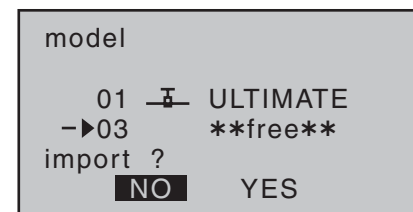

You can interrupt the process with **NO**; if you do this, you are returned to the starting screen. However, if you use the ► button to select **YES**, and confirm your choice by touching the **SET** button, then the selected model is imported into the selected model memory.

Notes:

- If the warning ...



... appears instead of a model selection, there is no SD card in the card slot; see page 22.

- When you import a model memory, the binding data is copied along with the model data, so that the receiving system associated with the original model memory can also be operated using the SAME transmitter and the copied memory without repeating the binding procedure.

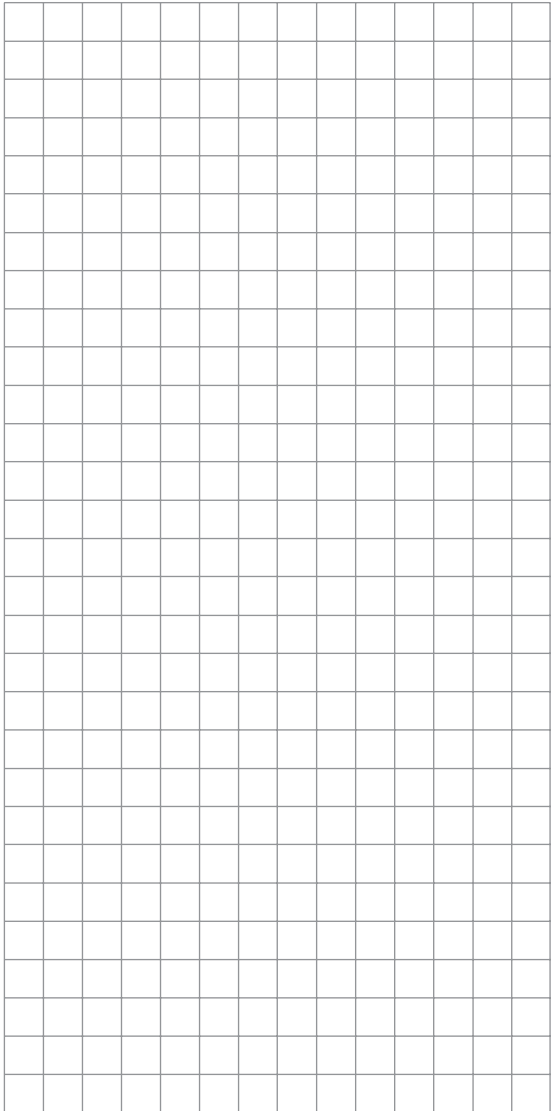
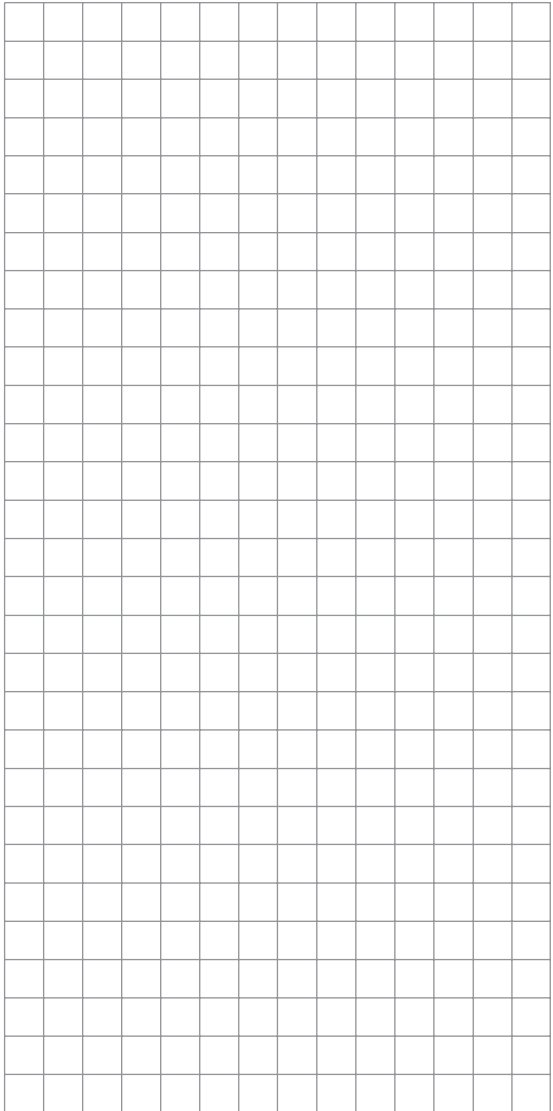
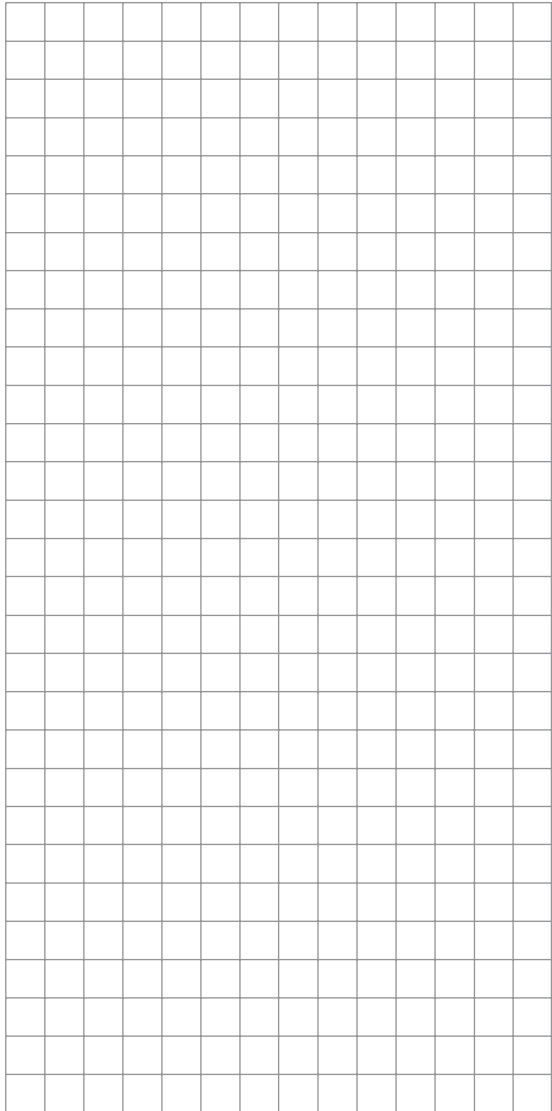

Base settings

Basic model-specific settings for fixed-wing model aircraft

Before you start programming specific parameters, some basic settings must be entered which apply only to the currently active model memory. Select the **“Basic settings”** (basic model settings) menu using the arrow buttons of the left or right-hand touch-key, then touch the central **SET** button of the right-hand touch-key:

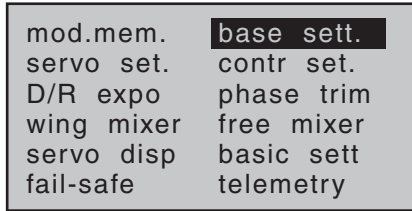

model name

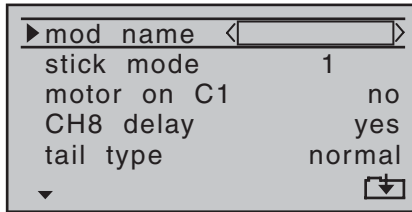

Touch the **SET** button of the right-hand touch-key to move to the next screen page, where you can select characters to assemble the model name. You can enter up to nine characters to define a model name:

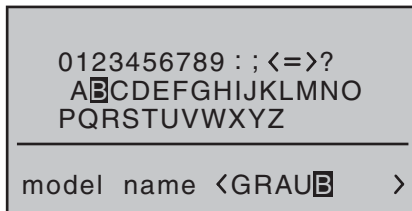

Use the arrow buttons of the left-hand touch-key to select the desired character, then move to the next position

in the name by touching one of the arrow buttons ◀ ▶ of the right-hand touch-key, or its central **SET** button. Simultaneously pressing the ▲ ▼ or ◀ ▶ buttons of the right-hand touch-key (**CLEAR**) inserts a space at that point.

You can move to any character position within the input field using the ◀ ▶ buttons of the right-hand touch-key. Touching the central **ESC** button of the left-hand touch-key returns you to the previous menu page.

The model name entered in this way appears in the basic display, and also in the sub-menus of the **“Model memory”** menu.

stick mode

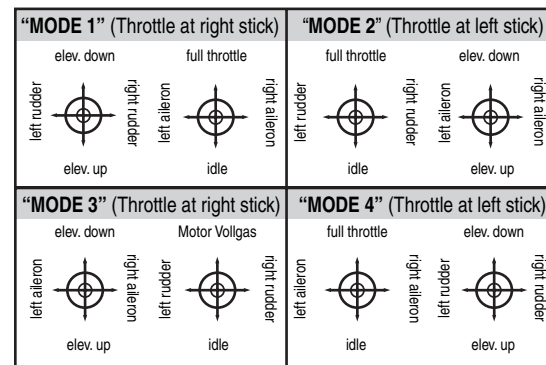

Basically there are four possible ways of arranging the principal control functions of a fixed-wing model on the two dual-axis sticks: the primary functions are aileron, elevator, rudder and throttle (or airbrakes). Which of these options you select depends on your individual preferences and flying style.

Use the arrow buttons ▲ ▼ of the left or right-hand touch-key to move to the **“Stick mode”** line. You will see

the Select field framed:

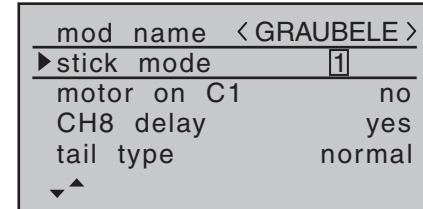

Briefly press the **SET** button to highlight the current stick mode (black background). Now use the arrow buttons of the right-hand touch-key to select one of the options 1 to 4.

Simultaneously pressing the ▲ ▼ buttons or the ◀ ▶ buttons of the right-hand touch-key (**CLEAR**) returns the display to stick mode “1”.

Touching the **SET** button again disables the select field once more, so that you can switch lines.

motor on C1

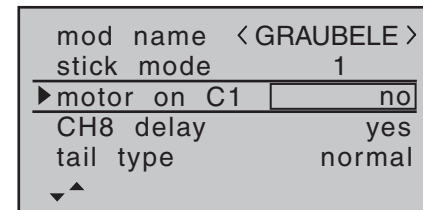

When you select “motor on C1” using the arrow buttons ▲ ▼ of the left or right-hand touch-key, you will see the corresponding input field framed. Touch the central **SET** button of the right-hand touch-key to highlight the current setting. Now use the arrow buttons of the right-hand touch-key to switch between the four possible options:

“idle fr.”: The idle position of the throttle / airbrake stick (C1) is forward, i.e. away from the pilot.

The throttle warning message “Throttle too high”, see page 28, and the option “cut off” are *activated*. In the “**Wing mixer**” menu the “Brake → NN *” mixers and the option “CH8 delay” are *disabled*.

“idle re.”: The idle position of the throttle / airbrake stick (C1) is back, i.e. towards the pilot.

The throttle warning message “Throttle too high”, see page 28, and the –following–option “cut off” are *activated*. In the “**Wing mixer**” menu the “Brake → NN *” mixers and the option “CH8 delay” are *disabled*.

“no”:
The brake system is “retracted” in the *forward* position of the throttle / brake stick. In the “**Wing mixer**” menu the “Brake → NN *” mixers are *activated*.

The throttle warning message “Throttle too high”, see page 28, and the option “cut off” are *disabled*.

„no/inv“
The brake system is “retracted” in the *back* position of the throttle / brake stick. In the “**Wing mixer**” menu the “Brake → NN *” mixers are *activated*.

The throttle warning message “Throttle too high”, see page 28, and the option “cut off” are *disabled*.

Notes:

- **Please note that a glowplug engine or electric motor could burst into life accidentally if the receiving system is switched on when you are programming the transmitter. To be on the safe side, disconnect the fuel tank or the flight battery.**

* NN = Nomen Nominandum (name to be stated)

- Depending on your choice in this menu, the Ch 1 trim acts “normally” (over the full control travel), or just at the idle end of the range, i.e. only at the “back” or “forward” end of the stick travel.
- Please note the **Cut-off trim** function, which is described on page 40.

CH8 delay

Notes:

- If you select “Idle forward / back” in the “Motor at C1” line, this menu line is suppressed.
- **This option is also only effective if you have activated at least one flight phase; see below under “Phases”.**

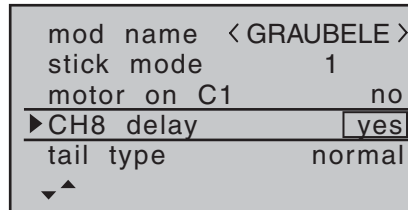

If you select “no”, the transition delay for control channel 8 of about one second, which takes effect every time you switch flight phases, is switched off; selecting “yes” switches it on.

When you select the “K8 delayed” line using the arrow buttons ▲ ▼ of the left or right-hand touch-key, the corresponding input field is framed. Briefly press the central **SET** button of the right-hand touch-key to highlight the current setting (black background). Now use the arrow buttons of the right-hand touch-key to select one of the two options.

cut off

Note:

This menu line is suppressed if you choose “none” or “none/inv” in the “Motor at Ch 1” line.

Depending on your selected setting for “Idle forward / rear” in the “motor on C1” line, you can select in this menu line a “Motor OFF” position which can be called up using a switch. The default settings are -100% for the throttle servo position, and +150% for the transmitter control position.

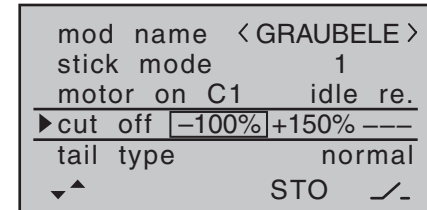

If you wish to change the default value of the throttle servo’s “Motor OFF” position, briefly press the central **SET** button of the right-hand touch-key to highlight the current setting. Use the arrow buttons of the right-hand touch-key to set a value at which the motor is reliably “off”, but without stalling the throttle servo; a typical value is -125%:

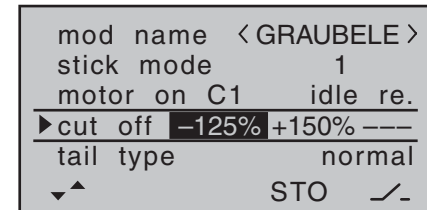

The - high - default value in the centre column ensures that the motor can be stopped over the maximum possi-

here. The software provides a maximum of twelve ready-made mixers for up to two aileron servos and two camber-changing flap servos.

Note:

If your model is equipped with only one flap servo, you should still select “2ail2fl”, but leave the “AIL → FL” mixer in the “Wing mixer” menu, which is described on page 91, at 0%. In contrast, all the other wing mixers can be used in the usual way. The second flap socket which is now “vacant” must ON NO ACCOUNT be used for any other purpose!

timer

Two timers are shown in the basic display: one stopwatch and one flight timer:

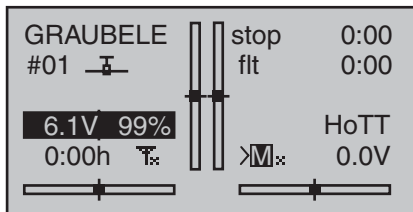

You can assign a physical switch or a control switch to these two timers in the right-hand column of the “timer” line, indicated by the switch symbol  at the bottom edge of the screen.

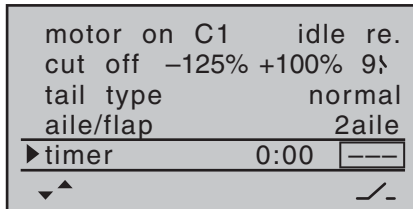





The assigned switch starts both timers, and also halts

the stopwatch.

The method of assigning a physical switch or a control switch is described on page 39.

The flight timer, and the saving of telemetry data on a memory card fitted in the card slot (see page 22), always starts simultaneously with the stopwatch, but continues to run even when the stopwatch is halted (switched off). It can only be stopped by touching the central **ESC** button of the left-hand touch-key when the stopwatch is already halted.

Once the timers are stopped, you can reset both timers to their initial value by briefly pressing the   or   buttons of the right-hand touch key (**CLEAR**).





Switching between “count-up” and “count-down”

Count-up timer (stopwatch function)

If you assign a switch and start the stopwatch with the initial value of “0:00”, the timer runs up until the maximum of 180 minutes and 59 seconds, then re-starts at 0:00.





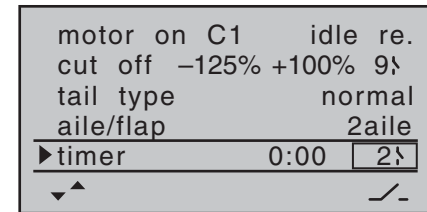

Count-down timer (alarm timer function)

You can select a starting time within the range 0 to 180 minutes in the left-hand minutes field, and a starting time within the range 0 to 59 seconds in the right-hand seconds field. Any combination of times can also be selected.

Simultaneously touching the   or   buttons of the right-hand touch-key (**CLEAR**) resets any settings you have made to “0” or “00”.



Procedure

1. Select the desired input field using the arrow buttons   of the left or right-hand touch-key.
2. Touch **SET** in the centre of the right-hand touch-key.
3. Select the required time in the highlighted minutes and seconds fields using the arrow buttons of the right-hand touch-key.
4. Touch the central **SET** button to conclude the input process.
5. Once you have switched back to the basic display by touching the central **ESC** button of the left-hand touch-key the required number of times, touch the   or   buttons of the right-hand touch-key (**CLEAR**) simultaneously, with the stopwatch stopped, to switch the stopwatch to the “Timer” function; see top right in the following illustration:

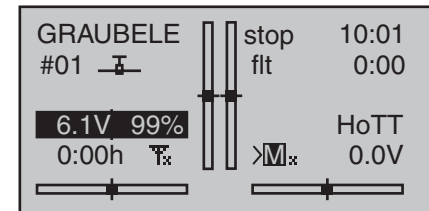

When you operate the assigned switch, the stopwatch now starts from the set initial value, *counting down* (“Timer function”). When the set time has elapsed, the

timer does not stop, but continues to run so that you can read off the time elapsed after reaching zero. To make this clear, the over-run time is shown highlighted (black background).

Sequence of sounds

- 30 sec. before zero: triple beep
single beep every two seconds
- 20 sec. before zero: double beep
single beep every two seconds
- 10 sec. before zero: single beep
single beep every second
- 5 sec. before zero: single beep every second at higher rate
- zero: longer beep; display switches to inverse video

The “alarm timer” is reset by simultaneously touching the ▲▼ or ◀▶ buttons of the right-hand touch-key (CLEAR), once you have halted the timer.

Note:
A count-down timer is indicated in the basic display by a flashing colon (:) between the minutes field and the seconds field.

Phase 2, Phase 3 and Phase 4

You will automatically be in the “normal” flight phase 1 unless you have already assigned a switch to phases 2, 3 or 4.

Both the number and name of this flight phase are fixed permanently as “normal”, and cannot be changed. For this reason the “normal” phase is simply concealed, i.e. it is not displayed as phase 1.

ail/flap	timer	10:01	2↖
phase 2	takeoff	----	
phase 3	speed	----	
▶ phase 4	landing	----	
▼▲			↙↘

It is also important to understand that the flight phases have their own inherent priorities which need to be observed, particularly when assigning individual switches. The underlying scheme can be described as follows:

- If all assigned flight phase switches are closed or open, the “normal” flight phase is active.
 - If only one switch is closed, then the flight phase assigned to the currently closed switch is active.
 - If two switches are closed, then the flight phase with the lower number is active.
- For example, this would be phase 2, if one of the switches assigned to phase 3 or 4 is also closed, or phase 3, if the switches assigned to phases 3 and 4 are closed.
- As a result you may wish to take the inherent phase priorities into account when assigning names to the flight phases; see below.
 - At the servo end the transition does not occur “abruptly”, but with a fixed transition period of about one second.

Programming

When you select “phase 2”, “phase 3” or “phase 4” using the arrow buttons ▲▼ of the left or right-hand touch-key, the “Name” field for that flight phase is already framed.

If the default name does not seem appropriate, touch

the central **SET** button of the right-hand touch-key, and the current setting is shown highlighted. Now use the arrow buttons of the right-hand touch-key to select an appropriate name from those available. Touch the **SET** button to conclude the input process.

Now press the ▶ button of the left or right-hand touch-key to move to the right-hand column at the bottom of the screen, indicated by the switch symbol ↙↘, and briefly touch the central **SET** button. You can now assign a switch to the phase as described on page 39. We recommend one of the two three-position switches SW 4/5 or SW 6/7, in each case starting from the centre toggle position.

For more information on flight phase programming please refer to page 86, in the section entitled “Phase trim”.

Receiver output

For maximum flexibility in terms of receiver socket assignment, the **mx-16** HoTT software provides the means to swap over the servo outputs 1 to max. 8; this is carried out on the second page of the “Receiver output” sub-menu.

timer	10:01	2↖
phase 2	takeoff	7↖
phase 3	speed	----
phase 4	landing	6↖
▶ receive out		⇒
▼▲		↙↘

Touch the central **SET** button of the right-hand touch-key to move to the next page of the display. Here you can assign the “control channels” for servos 1 ... 8 to any receiver output you wish to use. However, please note

that the display in “Servo display” - which you can access from virtually any menu position by simultaneously touching the ◀ and ▶ buttons of the left-hand touch-key - refers exclusively to the “control channels”, i.e. the outputs are NOT swapped over.

▶ S	1	→	output	1
S	2	→	output	2
S	3	→	output	3
S	4	→	output	4
S	5	→	output	5
▼				

Use the arrow buttons ▲ ▼ of the left or right-hand touch-key to select the servo / output combination you wish to change, then touch the central **SET** button of the right-hand touch-key. Now you can assign the desired servo(s) to the selected output using the right-hand arrow buttons, and confirm your choice with **SET** ... or alternatively touch the ▲ ▼ or ◀ ▶ buttons of the right-hand touch-key (**CLEAR**) simultaneously to revert to the default sequence.

Please note that any subsequent changes to servo settings, such as servo travel, Dual Rate / Expo, mixers etc., **must be carried out according to the original (default) receiver socket sequence.**

Note:

*It is also possible to distribute the control functions amongst as many receivers as you wish, using the channel-mapping function in the **mx-16** HoTT's integral Telemetry menu, or even to assign the same control function to multiple receiver outputs. For example, you might wish to actuate each aileron with two servos instead of just one, etc. However, we strongly recommend that you use only one of the two options, as a combina-*

tion will soon lead to confusion.

rx bind

Graupner HoTT receivers have to be “instructed” to communicate exclusively with a particular model (i.e. model memory) of a *Graupner* HoTT transmitter. This process is known as “binding”, and is only necessary once for each new combination of receiver and model.

Important note:

When carrying out the binding procedure, please ensure that the transmitter aerial is always an adequate distance from the receiver aerials: keeping the aerials about 1 m apart is safe in this respect. Otherwise you risk a failed connection to the down-link channel, and consequent malfunctions.

“Binding” multiple receivers to one model

If necessary, it is possible to bind more than one receiver to a single model. This is accomplished by initially binding the receivers individually, as described in the next section. **When operating the system, please note that only the receiver which was bound last will establish a telemetry link to the transmitter.** For this reason all telemetry sensors installed in the model must be connected to this receiver, since only the last bound receiver is able to transmit their data via the down-link channel. The second, and all other receivers, run in parallel to the receiver last bound to the transmitter, but completely independently of it; they operate in Slave mode with the down-link channel switched off.

“Binding” transmitter and receiver

Use the arrow buttons ▲ ▼ of the left or right-hand touch-key to move to the “rx bind” line:

phase 2	takeoff	7↵
phase 3	speed	---
phase 4	landing	6↵
receiv out		=>
▶ rx bind		---
▼ ▲		

If you have not already done so, switch on the power supply to your receiver now: the red LED on the receiver flashes.

Press and hold the **SET** button on the receiver until, after about three seconds, the red-flashing LED starts to flash red / green; this will last for a further three seconds. You can now release the **SET** button on the receiver. The receiver is in Bind mode as long as the LED flashes red / green.

Within this period of about three seconds briefly touch the central **SET** button of the right-hand touch-key to initiate the binding process between a receiver and the current model memory. At the same time the word “BINDING” starts flashing on the screen in the frame of the “Bound receiver” line, instead of the three “---”:

phase 2	takeoff	7↵
phase 3	speed	---
phase 4	landing	6↵
receiv out		=>
▶ rx bind		BINDING
▼ ▲		

The receiver LED is now flashing red again, and if it goes out without about ten seconds, and instead glows a constant green, then the binding process has been completed successfully. Your model / receiver combination is now ready for use. In parallel with this the screen

displays the code number for the receiver now “bound” to this model memory. For example:

```
phase 2    takeoff  7\
phase 3    speed    ---
phase 4    landing  6\
receiv out  =>
▶ rx bind   R08
▼▲
```

If, in contrast, the red LED on the receiver flashes for longer than about ten seconds, then the binding process has failed. In parallel with this the screen will display three “---” once more. If this should occur, alter the relative position of the aerials, and repeat the whole procedure.

range test

The integral range-check reduces the transmitter's output power in such a way that you can test the system's operation at a distance of up to about fifty metres.

Carry out the range-check of the *Graupner* HoTT system in accordance with the following instructions. We recommend that you ask a friend to help with range-checking.

1. Install the receiver in the model as required, preferably after completing the binding process with the transmitter.
2. Switch the radio control system on and wait until the green LED on the receiver glows. Now you can observe the servo movements.
3. Place the model on a flat surface (paving, close-mown grass or earth), with the receiver aerials at least 15 cm above the ground. This means that you may have to place the model on a raised object for the pe-

riod of the check.

4. Hold the transmitter at hip-height, and away from your body. However, do not point the aerial straight at the model; instead rotate and / or angle the tip of the aerial so that it is vertical while you carry out the check.
5. If you have not already done so, use the arrow buttons ▲ ▼ of the left or right-hand touch-key to move to the “Test range” line, and initiate range-check mode by briefly pressing the central **SET** button of the right-hand touch-key:

```
phase 3    speed    ---
phase 4    landing  6\
receiv out  =>
rx bind    R08
▶ range test 99sec
▼▲
```

When you start the range-check, the transmitter's output power is significantly reduced, and the blue LED on the aerial base starts to flash. At the same time the time display on the transmitter screen starts counting down, and a double beep sounds every five seconds.

From five seconds before the end of the range-check you will hear a triple beep every second. When the 99 seconds of the range-check period have elapsed, the transmitter switches back to full power, and the blue LED glows constantly once more.

6. Within this period walk away from the model, moving the sticks all the while. If at any point within a distance of about fifty metres you notice a break in the connection, attempt to reproduce it.
7. If the model is fitted with a motor, switch it on in order to check the system's interference rejection.

8. Walk further away from the model until you no longer have full control over it.
9. At this point wait until the test period has elapsed, with the model still switched on and ready for use. When the range-check period is over, the model should respond again to control commands. If this is not 100% the case, do not use the system. Contact your nearest Service Centre of *Graupner* GmbH & Co. KG.
10. Carry out the range-check before every flight, and simulate all the servo movements which are likely to occur in a typical flight. To ensure safe operation of the model, the range must always be at least fifty metres on the ground.

Caution:

Never initiate a range-check when you are actually operating a model!

RF transmit

In this menu line you can manually switch the transmitter's RF transmission on and off again for a specific model for the current period that the transmitter is switched on. For example, you might wish to do this to save power when demonstrating the programming of a model. **If you switch the transmitter off with the RF module switched off, next time you switch the transmitter on it will be switched back on again.**

Use the arrow buttons ▲ ▼ of the left or right-hand touch-key to move to the “RF module” line, and touch the central **SET** button of the right-hand touch-key to activate the value window:

phase 4	landing	6\
receiv out		=>
rx bind		R08
range test		99sec
▶RF transmit		<input type="checkbox"/> OFF
▲		

Now you can use the right-hand arrow buttons to switch between OFF and ON. Touch the central **SET** button of the right-hand touch-key again to conclude the input.

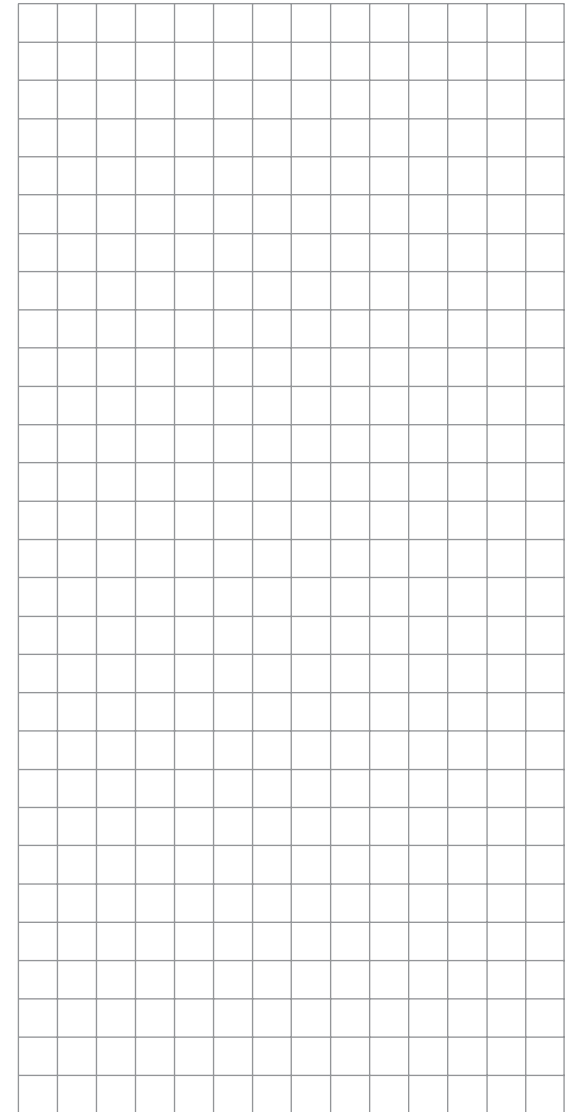

Base settings

Basic model-specific settings for model helicopters

Before you start programming specific parameters, some basic settings must be entered which apply only to the currently active model memory. Select the **"Basic settings"** (Basic model settings) menu using the arrow buttons of the left or right-hand touch-key, and press the central **SET** button of the right-hand touch-key:

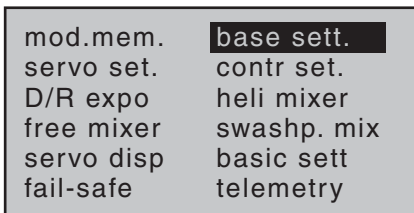

Model name

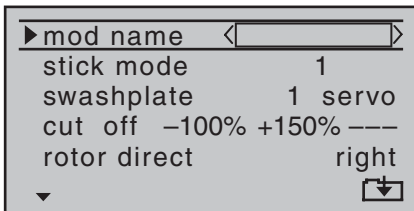

Touch the **SET** button of the right-hand touch-key to move to the next screen page, where you can select characters to assemble the model name. You can enter up to nine characters to define a model name:



Use the arrow buttons of the left-hand touch-key to select the desired character. Touch one of the arrow but-

tons ◀ ▶ of the right-hand touch button, or its central **SET** button, to move to the next position in the name, at which point you can again select a character. Simultaneously touching the ▲ ▼ or ◀ ▶ buttons of the right-hand touch-key (**CLEAR**) inserts a space at that point. You can move to any character position within the input field using the ◀ ▶ buttons of the right-hand touch-key. You can return to the previous menu page by briefly pressing the central **ESC** button of the left-hand touch-key.

The model name entered in this way appears in the basic display, and also in the sub-menus of the **"Model memory"** menu point.

Stick mode

Basically there are four possible ways of arranging the principal control functions of a model helicopter on the two dual-axis sticks: the primary functions are roll, pitch-axis, tail rotor and throttle / collective pitch. Which of these options you select depends on your individual preferences and flying style:

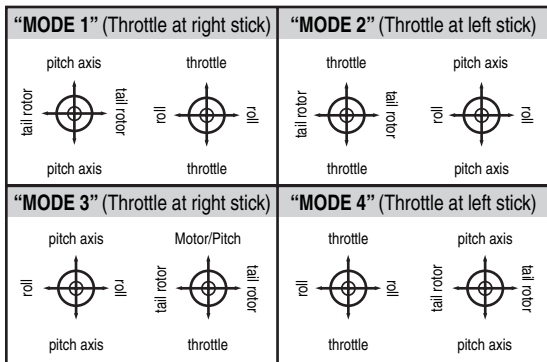

Use the arrow buttons ▲ ▼ of the left or right-hand touch-key to select the **"Stick mode"** line; the select field

is now framed:

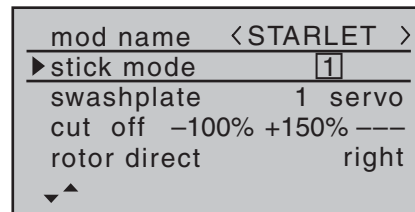

Briefly press the **SET** button: the current stick mode appears highlighted. Now use the arrow buttons of the right-hand touch-key to choose one of the options 1 to 4. By simultaneously touching the ▲ ▼ or ◀ ▶ buttons of the right-hand touch-key (**CLEAR**) the display reverts to stick mode "1".

A further brief press on the **SET** button disables the select field again, so that you can change to a different line.

Swashplate type

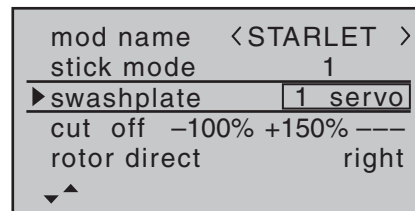

You will require a particular program variant to suit the number of servos which operate the collective pitch function.

Select "Swashplate" with the arrow buttons ▲ ▼ of the left or right-hand touch-key, and the select field is framed. Touch the **SET** button: the current number of collective pitch servos is highlighted on the screen. You can now determine the required variant using the arrow

buttons of the right-hand touch-key:

“1 servo”: The swashplate is tilted by one roll servo and one pitch-axis servo. Collective pitch is controlled by one separate servo.

The “**Swashplate mixer**” menu point is suppressed in the multi-function menu if you select “1 servo” as the swashplate type. This is because model helicopters with only one collective pitch servo are controlled WITHOUT transmitter mixers for the swashplate functions collective pitch, pitch-axis and roll.

“2 servo”: The swashplate is moved axially by two roll servos for collective pitch control; pitch-axis control is de-coupled by a mechanical compensating rocker.

“3sv(2rol)”: A symmetrical three-point swashplate linkage using three linkage points arranged equally at 120°, actuated by one pitch-axis servo (front or rear) and two roll servos (left and right). For collective pitch control all three servos move the swashplate axially.

“3sv(140)”: Asymmetrical three-point swashplate linkage using three linkage points, connected to one pitch servo (rear) and two roll servos (front left and right). For collective pitch control all three servos move the swashplate axially.

“3sv(2nic)”: A symmetrical three-point linkage as above, but rotated through 90°, i.e. one roll servo on one side, and two pitch-axis servos front and rear.

“4sv(90)”: Four-point swashplate linkage using two

roll and two pitch-axis servos.

Simultaneously pressing the ▲▼ or ◀▶ buttons of the right-hand touch-key (**CLEAR**) resets the swashplate type to “1 servo”.

Swashplate type: 1 servo

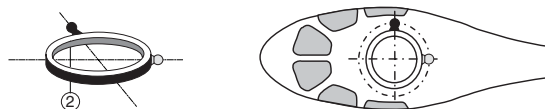

Swashplate type: 2 servos

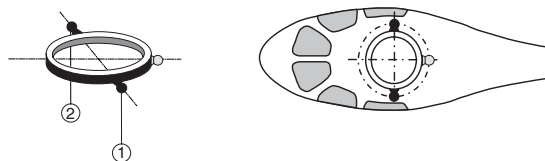

Swashplate type: 3 servos (2 roll)

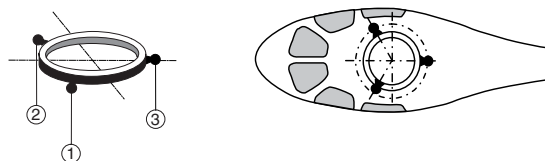

Swashplate type: 3 servos (140°)

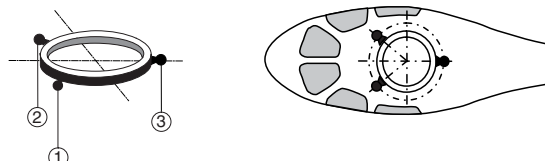

Swashplate type: 3 servos (pitch-axis)

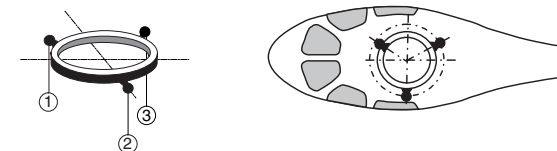

Swashplate type: 4 servos (90°), 2 pitch / 2 roll

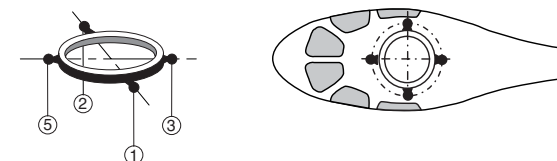

Note:

With the exception of the “1 servo” pre-set, the swashplate mixer ratios are set in the “**Swashplate mixers**” menu; see page 112.

Cut off

As part of the auto-rotation set-up procedure of the **mx-16** HoTT transmitter’s Helicopter program there is the option to define a “motor OFF” position for the throttle servo or speed controller for use in an emergency. However, if you set an idle position in the “Throttle” line instead of an emergency OFF position - for example, in order to avoid having to re-start the engine after every practice auto-rotation landing - then this option is not available. In this case we recommend that you use the “Motor stop” option described below as the emergency OFF solution. Depending on the option (“forward / back”) you have selected in the “Collective pitch minimum” line, you can define a “Motor OFF” position in this menu line which can be called up by operating a switch. The

default settings are -100% for the “Motor OFF” position of the throttle servo and +100% for the throttle curve:

```

mod name < STARLET >
stick mode      1
swashplate      3sv(2rol)
▶cut off -100% +100% ----
rotor direct    right
▼▲             STO  /-
  
```

If you wish to change the default value of the throttle servo’s “Motor OFF” position, briefly press the central **SET** button of the right-hand touch-key: the current setting is highlighted. Now use the arrow buttons of the right-hand touch-key to set a value at which the motor is reliably “off”, but without stalling the servo. For example: -125%:

```

mod name < STARLET >
stick mode      1
swashplate      3sv(2rol)
▶cut off -125% +100% ----
rotor direct    right
▼▲             STO  /-
  
```

The - high - default value in the centre column ensures that the motor can be stopped over the maximum possible range of the throttle curve using the switch which has yet to be assigned in the right-hand column.

However, if you want to set an individual threshold after which it is possible to switch to the motor OFF position, then move the throttle / collective pitch stick to the position you desire, and briefly press the central **SET** button of the right-hand touch-key:

```

mod name < STARLET >
stick mode      1
swashplate      3sv(2rol)
▶cut off -125% +100% ----
rotor direct    right
▼▲             STO  /-
  
```

Note:

You can obtain a switching threshold of more than +100% by temporarily increasing the travel of servo 1 to more than 100% in the “Servo settings” menu, then returning it to the original value after storing the switching threshold.

In the right-hand column you can now assign a switch which can be used (in an emergency) to cut the motor. We recommend one of the two self-centring momentary buttons SW 1 or 9:

```

mod name < STARLET >
stick mode      1
swashplate      3sv(2rol)
▶cut off -125% +100% 1↓
rotor direct    right
▼▲             STO  /-
  
```

Direction of rotation of main rotor

```

mod name < STARLET >
stick mode      1
swashplate      3sv(2rol)
cut off -125% +100% 1↓
▶rotor direct   right
▼▲
  
```

In the “Rotor direction” line you enter the direction of

rotation of the main rotor using the arrow buttons of the right-hand touch-key, after briefly pressing the central **SET** button:

“right”: the main rotor spins clockwise as viewed from above.

“left”: the main rotor spins anti-clockwise as viewed from above.

Simultaneously touching the ▲▼ or ◀▶ buttons of the right-hand touch-key (**CLEAR**) switches to “right”.

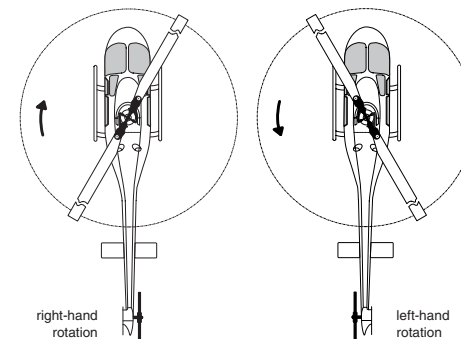

The program requires this information in order to set up the mixers to work in the correct “sense”; this applies to the mixers which compensate for rotor torque and motor power. You will find these in the “**Helicopter mixer**” menu:

- Pitch
- Ch1 → throttle
- Ch1 → tail rotor

Collective pitch min.

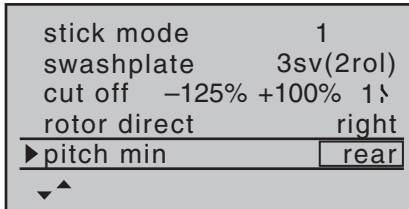

In the “Collective pitch min.” line you can set up the direction of operation of the throttle / collective pitch stick to suit your preference. This setting is crucial to the correct operation of all the other options in the helicopter program which affect the throttle and collective pitch functions, i.e. the throttle curve, idle trim, tail rotor mixer etc.

Briefly touch the central **SET** button of the right-hand touch-key, and the direction of operation of the throttle / collective pitch stick is highlighted. Now you can select the required variant using the arrow buttons of the right-hand touch-key:

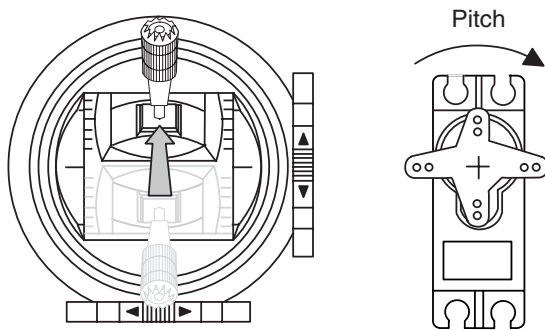

The meaning is as follows:

“front”: minimum collective pitch when the collective pitch stick (Ch 1) is “forward” (away from you);

“rear”: minimum collective pitch when the collective pitch stick (Ch 1) is “back” (towards you). Simultaneously pressing the ▲▼ or ◀▶ buttons of the right-hand touch-key (**CLEAR**) returns the collective pitch min. position to “rear”.

Note:

- The Ch 1 trim always affects the throttle servo only.
- By default what is known as the “throttle limiter” is set (see page 79); this limits the travel of the throttle servo in the direction of maximum throttle, acting separately from the collective pitch servos. This point can be programmed using the “Lim” input in the “Transmitter control settings” menu.

Timers

Two timers are shown in the basic display: one stopwatch and one flight timer.

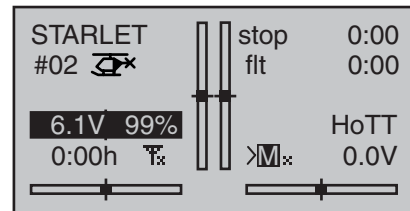

A physical switch or a control switch - e.g. the control switch G3 located on the throttle limiter - can be assigned to these two timers in the “Timers” line ...

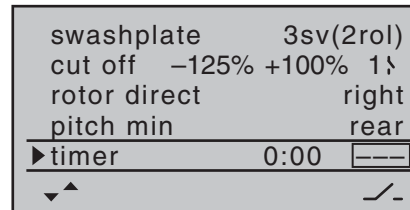

... using the switch symbol  at the bottom right-hand side of the screen. The assigned switch starts both timers, and also halts the stopwatch.

The method of assigning a physical switch or a control switch is described on page 39.

The flight timer, and the saving of telemetry data on a memory card inserted in the card slot (see page 22) always starts simultaneously with the stopwatch, but continues to run even when the stopwatch is halted (switched off). It can only be stopped by touching the central **ESC** button of the left-hand touch-key with the stopwatch halted.

Once stopped, both timers can be reset to the initial value by simultaneously touching the ▲▼ buttons of the right-hand touch-key (**CLEAR**).

Switching between “count-up” and “count-down”

Count-up timer (stopwatch function)

If you assign a switch and start the stopwatch with the initial value of “0:00”, the timer runs up until the maximum of 180 minutes and 59 seconds, then re-starts at 0:00.

Count-down timer (timer function)

In the left-hand minutes field you can select a starting time within the range 0 to 180 minutes; in the right-hand seconds field the range is 0 to 59 seconds. Any combination of times can also be selected.

Simultaneously pressing the ▲▼ buttons of the right-hand touch-key (**CLEAR**) resets any settings you have entered to “0” or “00”.

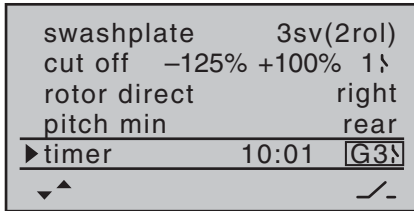

Procedure

1. Select the desired input field using the arrow buttons ◀ ▶ of the left or right-hand touch-key.
2. Touch **SET** in the centre of the right-hand touch-key.
3. Select the required time in the highlighted minutes and seconds fields using the arrow buttons of the right-hand touch-key.
4. Touch the central **SET** button to conclude the input process.
5. Switch back to the basic display by repeatedly touching the central **ESC** button of the left-hand touch-key. With the stopwatch halted, press the ▲ ▼ buttons of the right-hand touch-key simultaneously (**CLEAR**) to switch the stopwatch to the "Timer" function; see top right in the next illustration:

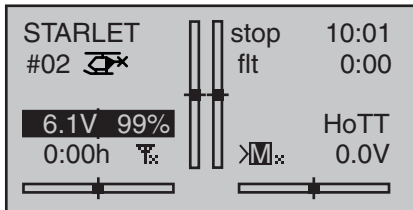

If you now operate the assigned switch, the stopwatch starts from the set initial value, *counting down* ("Timer function"). When the set time has elapsed, the timer does not stop, but continues to run to allow you to read

off the time elapsed after reaching zero. To make this clear, the over-run time is shown highlighted (black background).

Sequence of sounds

- 30 sec. before zero: triple beep
single beep every two seconds
- 20 sec. before zero: double beep
single beep every two seconds
- 10 sec. before zero: single beep
single beep every second
- 5 sec. before zero: single beep every second at higher rate
- zero: longer beep; display switches to inverse video

The "alarm timer" is reset by simultaneously pressing the ▲ ▼ or ◀ ▶ buttons of the right-hand touch-key (**CLEAR**) after you have halted the timer.

Note:

A count-down timer is indicated in the basic display by a flashing colon (:) between the minutes field and the seconds field.

Phase 2 / Phase 3

You will automatically be in the "normal" flight phase 1 unless you have already assigned a switch to phases 2 or 3.

Both the number and name of this flight phase are fixed permanently as "normal", and cannot be changed. For this reason the "normal" phase is simply concealed, i.e. it is not displayed as phase 1.

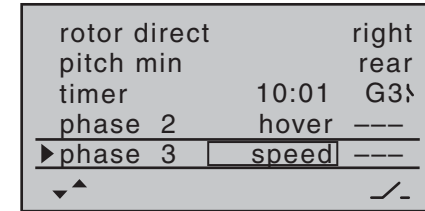

It is also important to understand that the flight phases have their own inherent priorities which need to be observed, particularly when assigning individual switches. The underlying scheme can be described as follows:

- If all assigned flight phase switches are closed or open, the "normal" flight phase is active.
- If only one switch is closed, then the flight phase assigned to the currently closed switch is active.
- If two switches are closed, then the flight phase with the lower number is active.

For example, this would be phase 2 if the switches assigned to phase 2 and 3 are closed.

- The "auto-rotation phase" ALWAYS has precedence over all other flight phases, regardless of the priorities outlined above. When the auto-rotation phase is selected, the switch is always made WITHOUT DELAY.
- With this in mind, you may wish to take the inherent phase priorities into account when assigning names to the flight phases; see below.
- At the servo end the transition does not occur "abruptly", but with a fixed transition period of about one second.

Programming

When you select "Phase 2" or "Phase 3" using the arrow buttons ▲ ▼ of the left or right-hand touch-key, the

“Name” field for that flight phase is already framed.

If the default name does not seem appropriate, touch the central **SET** button of the right-hand touch-key, and the current setting is shown highlighted. Now use the arrow buttons of the right-hand touch-key to select an appropriate name from those available. Touch the **SET** button to conclude the input process.

Now press the ► button of the left or right-hand touch-key to move to the right-hand column at the bottom of the screen, indicated by the switch symbol , and briefly touch the central **SET** button. You can now assign a switch to the phase as described on page 39. We recommend one of the two three-position switches SW 4/5 or SW 6/7, in each case starting from the centre toggle position.

For more information on flight phase programming please refer to page 94, in the section entitled “Flight phase specific settings for collective pitch, throttle and tail rotor”.

Auto-rotation

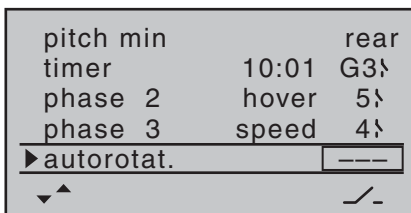

The name “Auto-rotation” is permanently assigned to Phase 4, and CANNOT be altered. The only available option is to assign a switch to it using the switch symbol at the right of the screen.

For more information on programming flight phases please refer to the “**Helicopter mixers**” section starting

on page 94.

Receiver output

For maximum flexibility in terms of receiver socket assignment, the **mx-16** HoTT software provides the means to swap over the servo outputs 1 to max. 8; this is carried out on the second page of the “Receiver output” sub-menu.

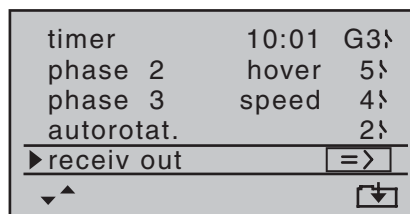

Touch the central **SET** button of the right-hand touch-key to move to the next page of the display. Here you can assign the “control channels” for servos 1 ... 8 to any receiver output you wish to use. However, please note that the display in “**Servo display**” - which you can access from virtually any menu position by simultaneously touching the ◀ and ▶ buttons of the left-hand touch-key - refers exclusively to the “control channels”, i.e. the outputs are NOT swapped over.

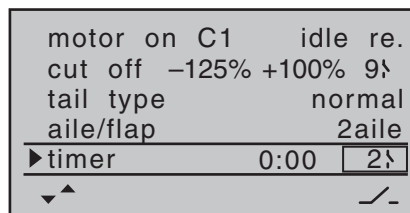

Use the arrow buttons ▲ ▼ of the left or right-hand touch-key to select the servo / output combination you wish to change, then touch the central **SET** button of the right-hand touch-key. Now you can assign the desired

servo(s) to the selected output using the right-hand arrow buttons, and confirm your choice with **SET** ... or alternatively touch the ▲ ▼ or ◀ ▶ buttons of the right-hand touch-key (**CLEAR**) simultaneously to revert to the default sequence.

Please note that any subsequent changes to servo settings, such as servo travel, Dual Rate / Expo, mixers etc., **must be carried out according to the original (default) receiver socket sequence.**

Typical application:

In the helicopter program of the **mx-16** HoTT the outputs for one collective pitch servo and the throttle servo have been interchanged compared to all earlier GRAUPNER/JR mc-systems. The throttle servo is now assigned to receiver output “6” and the collective pitch servo to output “1”. However, you may wish to retain the earlier configuration.

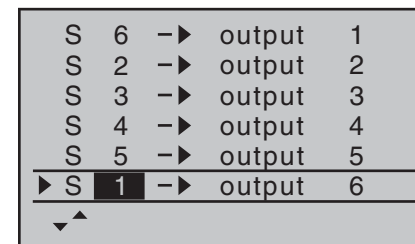

Note:

It is also possible to distribute the control functions amongst as many receivers as you wish, using the channel-mapping function in the **mx-16** HoTT's integral Telemetry menu, or even to assign the same control function to multiple receiver outputs. However, we strongly recommend that you use only one of the two options, as a combination will soon lead to confusion.

rx bind (Bound receiver)

Graupner HoTT receivers have to be “instructed” to communicate exclusively with a particular model (i. e. model memory) of a *Graupner* HoTT transmitter. This process is known as “binding”, and is only necessary once for each new combination of receiver and model.

Important note:

When carrying out the binding procedure, please ensure that the transmitter aerial is always an adequate distance from the receiver aerials: keeping the aerials about 1 m apart is safe in this respect. Otherwise you risk a failed connection to the down-link channel, and consequent malfunctions.

“Binding” multiple receivers to one model

If necessary, it is possible to bind more than one receiver to a single model. This is accomplished by initially binding the receivers individually, as described in the next section.

When operating the system, please note that only the receiver which was bound last will establish a telemetry link to the transmitter. For this reason all telemetry sensors installed in the model must be connected to this receiver, since only the last bound receiver is able to transmit their data via the down-link channel. The second, and all other receivers, run in parallel to the receiver last bound to the transmitter, but completely independently of it; they operate in Slave mode with the down-link channel switched off.

“Binding” transmitter and receiver

Use the arrow buttons ▲ ▼ of the left or right-hand touch-key to move to the “rx bind” line:

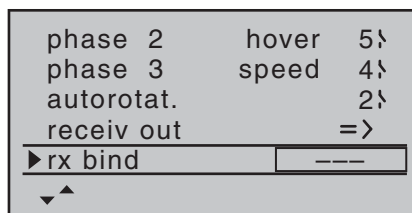

If you have not already done so, switch on the power supply to your receiver now: the red LED on the receiver flashes.

Press and hold the **SET** button on the receiver until, after about three seconds, the red-flashing LED starts to flash red / green; this will last for a further three seconds. You can now release the **SET** button on the receiver. The receiver is in Bind mode as long as the LED flashes red / green.

Briefly touch the central **SET** button of the right-hand touch-key within this period of about three seconds: this initiates the binding process between a receiver and the current model memory. At the same time the word “BINDING” starts flashing in the frame of the “rx bind” line on the screen, instead of the three “---”:

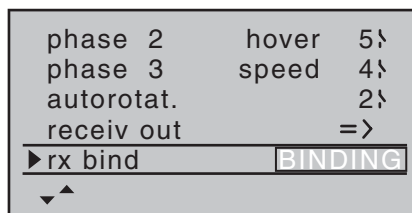

The receiver LED is now flashing red again, and if it goes out within about ten seconds, and instead glows a constant green, then the binding process has been completed successfully. Your model / receiver combination is now ready for use. In parallel with this the screen

displays the code number for the receiver now “bound” to this model memory. For example:

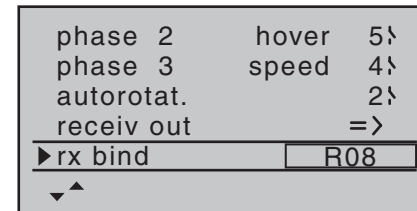

If, in contrast, the red LED on the receiver flashes for longer than about ten seconds, then the binding process has failed. In parallel with this the screen will display three “---” once more. If this should occur, alter the relative position of the aerials and repeat the whole procedure.

Range test

The integral range-check reduces the transmitter's output power in such a way that you can test the system's operation at a distance of up to about fifty metres.

Carry out the range-check of the *Graupner* HoTT system in accordance with the following instructions. We recommend that you ask a friend to help with range-checking.

1. Install the receiver in the model as required, preferably after completing the binding process with the transmitter.
2. Switch the radio control system on and wait until the green LED on the receiver glows. Now you can observe the servo movements.
3. Place the model on a flat surface (paving, close-mown grass or earth), with the receiver aerials at least 15 cm above the ground. This means that you may have to place the model on a raised object for the period of the check.

4. Hold the transmitter at hip-height, and away from your body. Do not point the aerial straight at the model; instead rotate and / or angle the aerial tip so that it is vertical while you carry out the check.
5. If you have not already done so, use the arrow buttons ▲ ▼ of the left or right-hand touch-key to move to the “Test range” line, and initiate range-check mode by briefly pressing the central **SET** button of the right-hand touch-key:

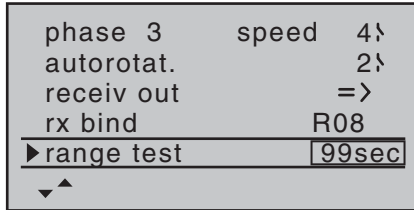

When you start the range-check, the transmitter's output power is significantly reduced, and the blue LED on the aerial base starts to flash. At this point the time display on the transmitter screen starts counting down, and a double beep sounds every five seconds.

From five seconds before the end of the range-check you will hear a triple beep every second. When the 99 seconds of the range-check period have elapsed, the transmitter switches back to full power, and the blue LED glows constantly once more.

6. Within this period walk away from the model, moving the sticks all the while. If at any point within a distance of about fifty metres you notice a break in the connection, attempt to reproduce it.
7. If the model is fitted with a motor, switch it on in order to check the system's interference rejection.
8. Walk further away from the model until you no longer

have full control over it.

9. At this point wait until the test period has elapsed, with the model still switched on and ready for use. When the range-check period is over, the model should respond again to control commands. If this is not 100% the case, do not use the system. Contact your nearest *Graupner* Service Centre.
10. Carry out a range-check before every flight, and simulate all the servo movements which are likely to occur in a typical flight. To ensure safe operation of the model, the range must always be at least fifty metres on the ground.

Caution:

Never initiate a range-check when you are actually operating a model!

RF transmit

In this menu line you can manually switch the transmitter's RF transmission on and off again for a specific model for the period that the transmitter is currently switched on. For example, you might wish to do this to save power when demonstrating the programming of a model. **If you switch the transmitter off with the RF module switched off, next time you switch the transmitter on it will be switched back on again.**

Use the arrow buttons ▲ ▼ of the left or right-hand touch-key to move to the “RF transmit” line, and touch the central **SET** button of the right-hand touch-key to activate the value window:

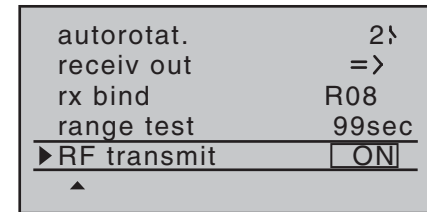

Now you can use the right-hand arrow buttons to switch between OFF and ON. Touch the central **SET** button of the right-hand touch-key again to conclude the input.



Servo settings

Servo direction, centre, travel

▶S1	=>	0%	100%	100%
S2	=>	0%	100%	100%
S3	=>	0%	100%	100%
S4	=>	0%	100%	100%
S5	=>	0%	100%	100%
▼	rev	cent	-	trav +

In this menu you can adjust parameters which only affect the servo connected to a particular receiver output, namely the direction of servo rotation, neutral point and servo travel. Always start with the servo setting in the left-hand column.v

Basic procedure:

1. Use the arrow buttons ▲▼ of the left or right-hand touch-key to select the relevant servo (1 to 8).
2. If necessary, use the arrow buttons ◀▶ of the left or right-hand touch-key to select the desired column, and move the associated transmitter control from its centre position if you wish to define an asymmetrical setting.
3. Touch the central **SET** button of the right-hand touch-key, and the corresponding input field is highlighted (black background).
4. Set the appropriate value using the arrow buttons of the right-hand touch-key.
5. Touch the central **SET** button of the right-hand touch-key to conclude the input process.
6. Simultaneously pressing the arrow buttons ▲▼ or ◀▶ of the right-hand touch-key (**CLEAR**) resets any settings you have entered to the default value.

Important:

The numbers in the servo designations refer to the receiver output socket to which a particular servo(s) is

connected, assuming that these have not been swapped over. This means that changing the stick mode does not affect the numbering of the servos.

Column 2 “Rev.”

The direction of servo rotation can be adjusted to suit the actual installation in your model. This means that you don't need to concern yourself with servo directions when installing the mechanical linkages in the model, as you can reverse them as and when necessary. The direction of rotation is indicated by the symbols “=>” and “<=”. Be sure to set the direction of servo rotation before you make adjustments to the remaining options!

Simultaneously pressing the arrow buttons ▲▼ or ◀▶ of the right-hand touch-key (**CLEAR**) resets the direction of rotation to “=>”.

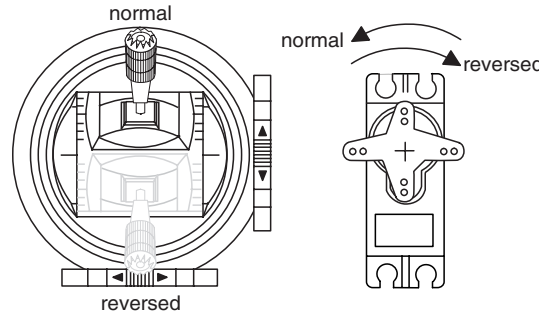

Column 3 “Centre”

The facility to offset the servo travel centre is intended for adjusting servos whose centre setting is not standard (servo centre point at 1.5 ms or 1500 µs), and also for minor adjustments, e.g. when fine-tuning the neutral position of the model's control surfaces.

The neutral position can be shifted over the range -125% to +125% of normal servo travel, within the maximum servo travel of +/- 150%, regardless of the trim lever position and any mixers you have set up. The setting affects the associated servo directly, independently of all other trim and mixer settings.

However, please note that an extreme shift of the servo's neutral point may result in servo travel to one side of neutral only, as total servo travel is limited to +/- 150% for both electronic and mechanical reasons.

Simultaneously pressing the arrow buttons ▲▼ or ◀▶ of the right-hand touch-key (**CLEAR**) resets the value in the highlighted input field to “0%”.

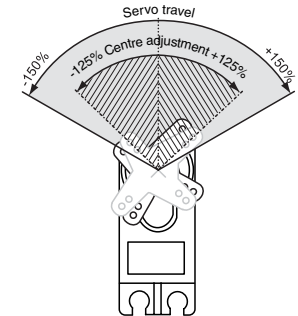

Column 4 “- Servo travel +”

In this column you can adjust servo travel symmetrically or asymmetrically (different each side of neutral). The adjustment range is 0 ... 150% of normal servo travel. The reference point for the set values is the setting in the “Centre” column.

To set *symmetrical* travel, i.e. to adjust travel equally on both sides of neutral, move the associated transmitter control (stick, proportional rotary knob or switch) to a position in which the marking frame encloses both sides of the travel setting.

Note:

You may need to assign a transmitter control to a servo which is connected to one of the control channels 5 ... 8; this is accomplished in the “**Transmitter control settings**” menu; see next page.

To set up *asymmetrical* travel, move the associated transmitter control (stick, rotary proportional knob or switch) to the side to be adjusted, so that the marking frame only encloses the value you wish to change.

Touch the central **SET** button of the right-hand touch-key to activate value adjustment; the value field is now highlighted. Use the arrow buttons of the right-hand touch-key to change the values. A further brief press on the central **SET** button of the right-hand touch-key concludes the input process.

Simultaneously pressing the arrow buttons ▲ ▼ or ◀ ▶ of the right-hand touch-key (**CLEAR**) resets the parameter in the highlighted input field to 100%.

Important:

In contrast to the “**Transmitter control settings**” menu, this setting affects the servo directly, regardless of how the control signal for this servo is generated, i.e. either

directly by a stick channel, or by means of any type of mixer function.

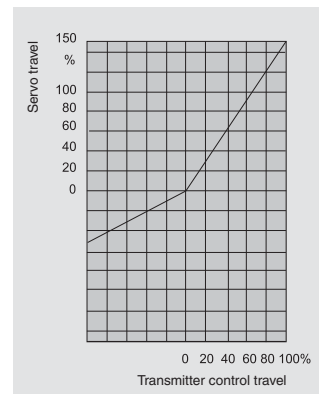

The graph alongside shows an example of asymmetrical servo travel, with a setting of -50% and +150%.

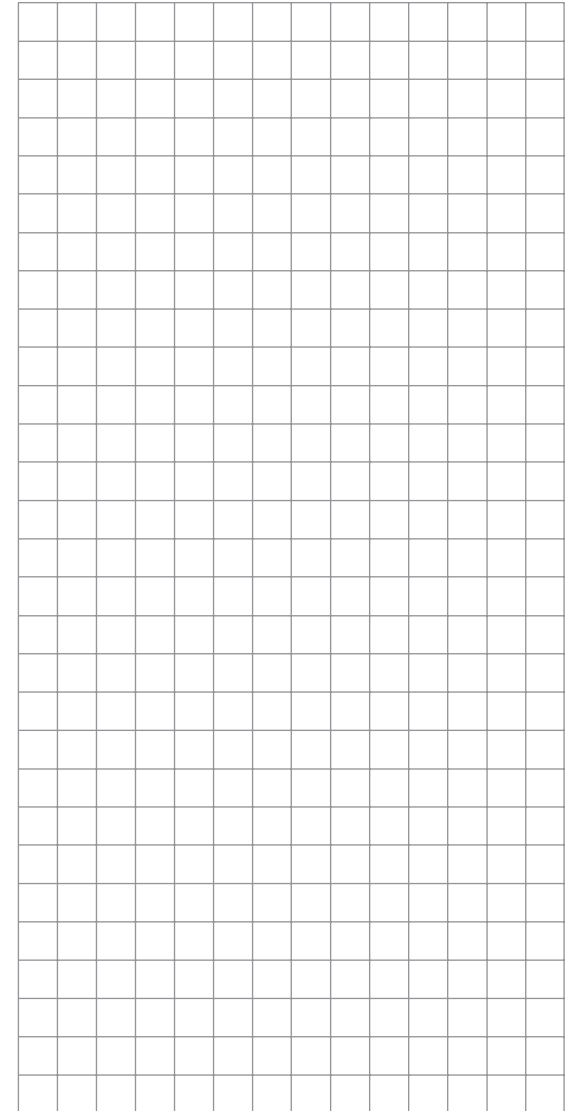

Transmitter control settings

Basic procedures for assigning transmitter controls and switches

▶ 15	free	+100%	+100%
16	free	+100%	+100%
17	free	+100%	+100%
18	free	+100%	+100%
▼		- trv	+

In addition to the two dual-axis stick units for the control functions 1 to 4, the **mx-16** HoTT is fitted as standard with a range of supplementary controls:

- Two three-position switches: SW 4/5 or CTRL 9 and SW 6/7 or CTRL 10. These are assigned in this menu as “CTRL 9” and “CTR 10” respectively.
- Three rotary proportional controls: CTRL 6, 7 and 8. These are included in the menu as “CTRL 6”, “CTRL 7” and “CTRL 8”.
- Three two-position switches: SW 2, 3 and 8. These are indicated in the menu by “2”, “3” and “8” plus a switch symbol, which indicates the direction of operation of the switch.
- Two momentary switches: SW 1 and SW 9. These are indicated by “1” and “9” plus a switch symbol and direction indicator, as mentioned above.

The two dual-axis stick units directly affect the servos connected to receiver outputs 1 ... 4 (assuming that you have set up a newly initialised model memory with the model type “Fixed-wing model”). In contrast, the “supplementary” transmitter controls listed above are inactive when the transmitter is in its default state (as delivered). As already mentioned on page 20, this means that the transmitter in its basic form only controls servos connected to receiver outputs 1 ... 4 using the primary sticks - even when you have initialised a new model memory with the model type “Fixed-wing model” and

“bound” it to the receiver you intend to install. Any servos connected to receiver sockets 5 ... 8 simply stay at their centre point when you operate the associated transmitter controls.

This may seem rather inconvenient at first sight, but it is the only way to ensure that you can select any of the “supplementary” transmitter controls for any task you like, and that you are not required deliberately to “program away” the transmitter controls which are not required for a particular model.

Any superfluous transmitter control will have an effect on your model if you operate it by mistake - unless it is inactive, i.e. unless no function is assigned to it.

That is why you can select these “supplementary” transmitter controls with complete freedom in the “Transmitter control settings” menu and assign them to any function input (see page 38) you like, as this method ensures that the transmitter meets your own requirements exactly. This also means that each of these transmitter controls can be assigned to several functions simultaneously. For example, the same toggle switch SW X, which you assign to an input in this menu, can also be assigned as the On / Off switch controlling the “Timers” in the “Basic settings” menu.

The basic procedure:

1. Select the appropriate input I5 ... I8 using the arrow buttons ▲ ▼ of the left or right-hand touch-key.
2. If necessary, use the arrow buttons ◀ ▶ of the left or right-hand touch-key to switch to the desired column.
3. Touch the central **SET** button of the right-hand touch-key, and the corresponding input field is highlighted.
4. Operate the transmitter control you wish to use, and

set the desired value using the arrow buttons of the right-hand touch-key.

5. Touch the central **SET** button of the right-hand touch-key to conclude the input process.
6. Simultaneously pressing the ▲ ▼ or ◀ ▶ buttons of the right-hand touch-key (**CLEAR**) resets any settings you have entered to the appropriate default value.

Column 2 “Assigning transmitter controls and switches”

Select one of the function inputs 5 to 8 using the ▲ ▼ buttons of the right-hand touch-key.

Touch the central **SET** button of the right-hand touch-key to activate the assignment facility.

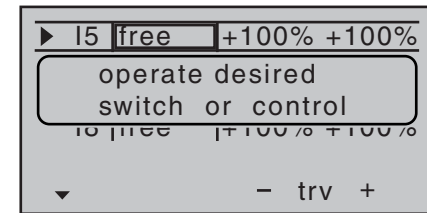

Now move the appropriate transmitter control (CTRL 6 to 10), or operate the selected switch (SW 1 to 3, 8 or 9). Note that the rotary proportional controls are not detected until they have moved a few “ratchet clicks”, i.e. they need to be operated for slightly longer. If the travel is not sufficient for the transmitter to detect it, move the control in the opposite direction.

If you assign one of the two-position switches, then this control channel works like an On / Off switch. It is then possible to switch to and fro between two end-point values using this simple switch, e.g. motor ON / OFF. The three-position switches SW 4/5 and 6/7, which you

will find in the “**Transmitter control settings**” menu as “Control 9” and “Control 10”, provide a centre position in addition to the two end-points.

Simultaneously pressing the ▲▼ or ◀▶ buttons of the right-hand touch-key (**CLEAR**) with the switch assignment activated - see illustration above - resets the input to “free”.

Tips:

- When assigning the switches please take care to set them to the appropriate direction of travel, and ensure that all inputs not required are left at or set to “free”, to eliminate the possibility of errors if unused transmitter controls are operated accidentally.
- You can alter the effective end-points of an assigned switch by adjusting servo travel, as described in the next section.

The screen now displays either the transmitter control number or the switch number, followed by a switch symbol which indicates the direction of operation, e.g.:

15	3	+100%	+100%
▶ 16	ctrl 7	+100%	+100%
17	free	+100%	+100%
18	free	+100%	+100%
▼▲		- trv +	

Column 3 “-Travel+”

In this column the transmitter control can be adjusted symmetrically or asymmetrically, i.e. different to either side. The available range is +/-125% of the normal servo travel.

Use the arrow buttons ▲▼ of the left or right-hand touch-key to select one of the inputs 5 to 8.

If you wish to set up *symmetrical* travel, i.e. the same in both directions, move the associated transmitter control (rotary proportional controls CTRL 6 ... 8 or switches 4/5 and 6/7) to a position at which the marking frame encloses both sides of the travel setting:

15	3	+100%	+100%
▶ 16	ctrl 7	+100%	+100%
17	free	+100%	+100%
18	free	+100%	+100%
▼▲		- trv +	

If you wish to set up *asymmetrical* travel, i.e. different for both directions, move the associated transmitter control (rotary proportional control or switch) to a position at which the marking frame encloses the side of the travel setting you wish to change:

15	3	+100%	+100%
▶ 16	ctrl 7	+100%	+100%
17	free	+100%	+100%
18	free	+100%	+100%
▼▲		- trv +	

Touch the central **SET** button of the right-hand touch-key to activate the value setting; the value field is now shown highlighted. Use the arrow buttons of the right-hand

touch-key to alter the values:

15	3	+100%	+100%
▶ 16	ctrl 7	+111%	+111%
17	free	+100%	+100%
18	free	+100%	+100%
▼▲		- trv +	

15	3	+100%	+100%
▶ 16	ctrl 7	+88%	+111%
17	free	+100%	+100%
18	free	+100%	+100%
▼▲		- trv +	

Touch the central **SET** button of the right-hand touch-key to conclude the input process.

Negative and positive parameter values are possible; this enables you to set the appropriate direction of movement of the transmitter control or its direction of effect to suit your model.

Simultaneously pressing the arrow buttons ▲▼ or ◀▶ of the right-hand touch-key (**CLEAR**) resets the altered parameter in the highlighted input field to +100%.

Important:

In contrast to servo travel adjustments, changing the transmitter travel setting affects all mixer and coupling inputs derived from it, i.e. in the final analysis all the servos which can be operated using the associated transmitter control.



Transmitter control settings

Basic procedures for assigning transmitter controls and switches

► I5	free	+100%	+100%
thr	free	+100%	+100%
gyr	free	+100%	+100%
I8	free	+100%	+100%
lim	ctrl 6	+100%	+100%
▼		- trv	+

In addition to the two dual-axis stick units for the control functions 1 to 4, the **mx-16** HoTT is fitted as standard with a range of supplementary controls:

- Two three-position switches: SW 4/5 or CTRL 9 and SW 6/7 or CTRL 10. These are assigned in this menu as “CTRL 9” and “CTR 10” respectively.
- Three rotary proportional controls: CTRL 6, 7 and 8. These are included in the menu as “Control 6”, “Control 7” and “Control 8”.
- Three two-position switches: SW 2, 3 and 8. These are indicated in the menu by “2”, “3” and “8” plus a switch symbol, which indicates the direction of operation of the switch.
- Two momentary switches: SW 1 and SW 9. These are indicated by “1” and “9” plus a switch symbol and direction indicator, as mentioned above.

The two dual-axis stick units directly affect servos connected to receiver outputs 1 ... 4 and 6 (assuming that you have set up a newly initialised model memory with the model type “Helicopter”). In contrast, the “supplementary” transmitter controls listed above are inactive when the transmitter is in its default state (as delivered). The exception is the rotary proportional knob CTRL 7 (throttle limiter), which acts upon servo 6 by default. As already mentioned on page 20, this means that the transmitter in its basic form only controls servos connected to receiver outputs 1 ... 4 using the primary

sticks, plus servo 6 - depending on the position of the throttle limiter - even when you have initialised a new model memory with the model type “Helicopter” and “bound” it to the receiver you intend to install. Any servos connected to receiver sockets 5, 7 and 8 simply stay at their centre point when you operate the associated transmitter controls.

This may seem rather inconvenient at first sight, but it is the only way to ensure that you can select any of the “supplementary” transmitter controls for any task you like, and that you are not required deliberately to “program away” the transmitter controls which are not required for a particular model.

Any superfluous transmitter control will have an effect on your model if you operate it by mistake, unless it is inactive, i.e. unless no function is assigned to it.

That is why you can select these “supplementary” transmitter controls with complete freedom in the “Transmitter control settings” menu, and assign them to any function input (see page 38) you like, as this method ensures that the transmitter meets your own requirements exactly. This also means that each of these transmitter controls can be assigned to several functions simultaneously. For example, the same toggle switch SW X which you assign to an input in this menu, can also be assigned as the On / OFF switch controlling the “Timers” in the “**Basic settings**” menu.

Note:

For model helicopters input 6 must always be left “free”. Please see the section entitled “Throttle” on the next double-page.

The basic procedure

1. Select the appropriate input I5, throttle, gyro, I8 or Lim using the arrow buttons ▲ ▼ of the left or right-hand touch-key.
2. If necessary, use the arrow buttons ◀ ▶ of the left or right-hand touch-key to switch to the desired column.
3. Touch the central **SET** button of the right-hand touch-key, and the corresponding input field is highlighted.
4. Operate the transmitter control you wish to use, and set the desired value using the arrow buttons of the right-hand touch-key.
5. Touch the central **SET** button of the right-hand touch-key to conclude the input process.
6. Simultaneously pressing the ▲ ▼ or ◀ ▶ buttons of the right-hand touch-key (**CLEAR**) resets any settings you have entered to the appropriate default value.

Column 2 “Assigning transmitter controls and switches”

Select one of the function inputs I5, throttle, gyro, I8 or lim using the ▲ ▼ buttons of the left or right-hand touch-key.

Touch the central **SET** button of the right-hand touch-key to activate the assignment facility.

► I5	free	+100%	+100%
operate desired switch or control			
I8	free	+100%	+100%
lim	ctrl 6	+100%	+100%
▼		- trv	+

Now move the appropriate transmitter control (CTRL 6 to 10), or operate the selected switch (SW 1 to 3, 8

or 9). Note that the rotary proportional controls are not detected until they have moved a few “ratchet clicks”, i.e. they need to be operated for slightly longer. If the travel is not sufficient for the transmitter to detect it, move the control in the opposite direction.

If you assign one of the two-position switches, then this control channel works like an On / Off switch. It is then possible to switch to and fro between two end-point values using this simple switch, e.g. motor ON / OFF. The three-position switches SW 4/5 and 6/7, which you will find in the “Transmitter control settings” menu as “CTRL 9” and “CTR 10”, provide a centre position in addition to the two end-points.

Simultaneously pressing the ▲▼ or ◀▶ buttons of the right-hand touch-key (**CLEAR**) with the switch assignment activated - see illustration above - resets the input to “free”.

Tips:

- When assigning the switches please take care to set them to the appropriate direction of travel, and ensure that all inputs not required are left at or set to “free”, to eliminate the possibility of errors if unused transmitter controls are operated accidentally.
- You can alter the effective end-points of an assigned switch by adjusting servo travel as described in the next section.

The screen now displays either the transmitter control number or the switch number, followed by a switch symbol which indicates the direction of operation, e.g.:

15	3	+100%	+100%
thr	free	+100%	+100%
▶ gyr	ctrl 7	+100%	+100%
18	free	+100%	+100%
lim	ctrl 6	+100%	+100%
▼▲		- trv	+

Column 3 “-Travel+”

In this column the transmitter control can be adjusted symmetrically or asymmetrically, i.e. different to either side. The available range is +/-125% of the normal servo travel.

Use the arrow buttons ▲▼ of the left or right-hand touch-key to select one of the inputs 15, throttle, gyro, 18 or lim.

If you wish to set up *symmetrical* travel, i.e. the same in both directions, move the associated transmitter control (rotary proportional control or switches 4/5 and 6/7) to a position at which the marking frame encloses both sides of the travel setting:

15	3	+100%	+100%
thr	free	+100%	+100%
▶ gyr	ctrl 7	+100%	+100%
18	free	+100%	+100%
lim	ctrl 6	+100%	+100%
▼▲		- trv	+

If you wish to set up *asymmetrical* travel, i.e. different for both directions, move the associated transmitter control (rotary proportional control or switch) to a position at which the marking frame encloses the side of the travel setting you wish to change:

15	3	+100%	+100%
thr	free	+100%	+100%
▶ gyr	ctrl 7	+100%	+100%
18	free	+100%	+100%
lim	ctrl 6	+100%	+100%
▼▲		- trv	+

Touch the central **SET** button of the right-hand touch-key to activate the value setting; the value field is now shown highlighted. Use the arrow buttons of the right-hand touch-key to alter the values:

15	3	+100%	+100%
thr	free	+100%	+100%
▶ gyr	ctrl 7	+111%	+111%
18	free	+100%	+100%
lim	ctrl 6	+100%	+100%
▼▲		- trv	+

15	3	+100%	+100%
thr	free	+100%	+100%
▶ gyr	ctrl 7	+88%	+111%
18	free	+100%	+100%
lim	ctrl 6	+100%	+100%
▼▲		- trv	+

Touch the central **SET** button of the right-hand touch-key to conclude the input process.

Negative and positive parameter values are possible; this enables you to set the appropriate direction of movement of the transmitter control or its direction of effect to suit your model.

Simultaneously pressing the arrow buttons ▲▼ or ◀▶ of the right-hand touch-key (**CLEAR**) resets the altered parameter in the highlighted input field to +100%.

Important:

In contrast to servo travel adjustments, changing the transmitter travel setting affects all mixer and coupling inputs derived from it, i.e. in the final analysis all the servos which can be operated using the associated transmitter control.

“Throttle”

15	3	+100%	+100%
▶ thr	free	+100%	+100%
gyr	ctrl 7	+100%	+100%
18	free	+100%	+100%
lim	ctrl 6	+100%	+100%
▼ ▲		- trv	+

In principle all transmitter controls (rotary proportional knob) and switches present on the transmitter can be assigned to the individual inputs within the Helicopter program.

However, please note that some inputs available in this menu are already pre-defined for helicopter-specific functions, and for this reason cannot be used without restriction.

For example, the receiver sequence printed on page 47 shows that the throttle servo (or the speed controller of an electric-powered model helicopter) must be connected to receiver output “6”, i.e. control channel “6” is reserved for motor speed control.

However, in contrast to a fixed-wing aircraft, the throttle servo or speed controller is not directly controlled by the throttle stick or any other transmitter control, but via a complex mixer system - see “**Helicopter mixers**” menu, starting on page 94. The “throttle limit function” (described on the next page) also has an influence on this mixer system.

Assigning a transmitter control or switch in the “Throttle” line, or its supplementary control signal, would only unnecessarily “confuse” this complex mixer system.

For this reason the “Throttle” input MUST always be left “free” when you are programming a model helicopter.

„Gyr“

15	3	+100%	+100%
thr	free	+100%	+100%
▶ gyr	ctrl 7	+100%	+100%
18	free	+100%	+100%
lim	ctrl 6	+100%	+100%
▼ ▲		- trv	+

If the gyro you are using features infinitely variable gain control, then you can pre-set the static gyro effect by setting an “offset” within the range +/-125%, separately for each flight phase, in the “Gyro” line of the “**Helicopter mixers**” menu - see the section starting on page 98.

Once you have entered these pre-defined - static - gain settings (set separately for each flight phase in the “**Helicopter mixers**” menu), you can use a transmitter control such as one of the rotary proportional controls CTRL 7 or 8 to vary gyro gain around the set “offset point”; all you have to do is assign that transmitter control in the “Gyro” line of this menu: in the centre position of the transmitter control this corresponds to the setting selected in the “**Helicopter mixers**” menu (see section starting on page 98). If the transmitter control is moved from this centre point in the direction of full travel, gyro gain is increased; towards the opposite end-point it is reduced. This is a fast, simple method of fine-tuning gyro gain when the model is in flight - perhaps to suit varying weather conditions - or alternatively to find the optimum setting. In software terms you can also limit the gain range to both sides by restricting the transmitter control travel. **However, please be sure to read the set-up notes provided with your gyro before carrying out these adjustments, as you could render your helicopter uncontrollable if you make a mistake.**

Throttle limit function

“Lim” input

By default the “lim” input is assigned to the rotary proportional control CTRL 6, which is located at top left on the transmitter:

15	3	+100%	+100%
thr	free	+100%	+100%
gyr	ctrl 7	+100%	+100%
18	free	+100%	+100%
▶ lim	ctrl 6	+100%	+100%
▲	- trv	+	

This pre-defined assignment eliminates the need to program two flight phases - “with idle-up” and “without idle-up” - as are often used by other radio control systems for this purpose, since the method of raising the system rotational speed below the hover point is more flexible with the **mx-16** HoTT program, and can be fine-tuned more accurately than using the conventional “idle-up” function. However, if you prefer to program your helicopter “with idle-up”, then switch off the “throttle limit” function, described below, by setting the “Lim” input to “free”.

Meaning and application of “throttle limit”

As mentioned previously under “Throttle”, the power output of the engine or motor of a model helicopter is not controlled directly using the throttle (Ch 1) stick - in contrast to fixed-wing model aircraft. Instead it is controlled indirectly by the throttle curve settings which you set up in the “**Helicopter mixers**” menu. Alternatively the throttle is controlled by the speed controller if the unit you are using is a *governor* or *regulator*.

Note:

Naturally it is possible to set up different throttle curves to suit different stages of flight using flight phase pro-

gramming.

By their very nature, both methods of controlling power have the same result, i.e. that a helicopter’s motor never gets anywhere near its idle speed during “normal” flying, so it is impossible to start or stop the motor easily unless some other means is used.

The “Throttle limiter” function solves this problem in an elegant manner: a separate transmitter control - as standard this is the rotary proportional control CTRL 6 located at top left on the transmitter - is employed to limit the setting of the throttle servo or the speed controller, which means that you can throttle right back to the idle position. At this setting the trim of the throttle / collective pitch stick assumes control, and can be used to switch off an electric motor directly. At the other extreme, the throttle servo or speed controller can, of course, only reach its full-throttle position if you release full servo travel using the throttle limit control. That is why the “lim” input is reserved in the Helicopter program for the “Throttle limiter” function.

For this reason the right-hand positive value in the “Travel” column must be large enough to ensure that it does not limit the full-throttle setting available via the throttle curve settings when the throttle limit control is at its maximum position. Usually this means a value in the range +100% to +125%. The left-hand negative value in the “Travel” column should be set in such a way that the throttle limit control reliably cuts the electric motor, or closes the throttle to the point where you can cut the I.C. motor using the (digital) Ch 1 trim. For this reason you should leave this value at +100%, at least for the time being.

This variable “limiting” of throttle travel provides a convenient means of starting and stopping the motor.

However, it also gives an additional level of safety if, for example, you have to carry your helicopter to the flight line with the motor running: you simply move the control to its minimum position, and this prevents any accidental movement of the Ch 1 stick affecting the throttle servo. If the carburettor is too far open (or the speed controller not at “stop”) when you switch the transmitter on, you will hear an audible warning, and the screen displays the message:

A rectangular box with a drop shadow containing the text "throttle too high!".

Tip:

You can call up the “**Servo display**” menu to check the influence of the throttle limit slider. This menu can be accessed from virtually any menu points by simultaneously pressing the ◀ ▶ buttons of the left-hand touch-key. Bear in mind that servo output 6 controls the throttle servo on the **mx-16** HoTT.

Basic idle setting

Start by turning the throttle limiter - by default the rotary proportional knob CTRL 6 located at top left on the transmitter - clockwise to its end-point. Move the throttle / collective pitch stick to the maximum position, and ensure that a standard throttle curve is active in the “Channel 1 → throttle” sub-menu of the ...

“**Heli mixer**” (page 94 ... 105)

... menu. If you have already altered the standard throttle curve which is present when you first initialise a model memory, then this should be reset to the values “Point 1 = -100%”, “Point 3 = 0%” and “Point 5 = +100%” - at least temporarily.

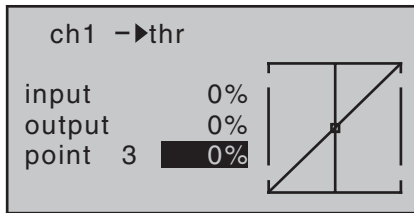

Note:

Since the throttle trim lever has no effect when the throttle limiter is open, its position is not relevant at this point.

Now - without starting the glow motor - adjust the mechanical linkage of the throttle servo so that the carburettor barrel is fully open; if necessary, carry out fine-tuning using the travel setting for servo 6 in the “**Servo settings**” menu.

Close the throttle limiter completely by turning the rotary proportional knob CTRL 6 anti-clockwise to its end-point. Use the trim lever of the throttle / collective pitch stick to move the trim position marker to the motor OFF position (see illustration in the right-hand column of the next page).

Note:

In contrast, when the throttle limiter is closed, the position of the throttle / collective pitch stick is not relevant; it can therefore be left in the maximum collective pitch position, i.e. the throttle linkage can be adjusted between full-throttle (throttle limiter open) and “motor OFF” (throttle limiter closed) using just the throttle limiter.

Now, with the throttle limiter closed, adjust the mechanical throttle linkage so that the carburettor is just fully closed. However, do check carefully that the throttle servo is not stalled at either of its extreme end-points (full-throttle / motor OFF).

To complete this basic set-up you still have to adjust the idle trim range to coincide with point “1” of the throttle curve. This is accomplished by setting point “1” of the “Ch 1 → throttle” mixer in the “**Heli mixer**” menu to a value of about -65 to -70%:

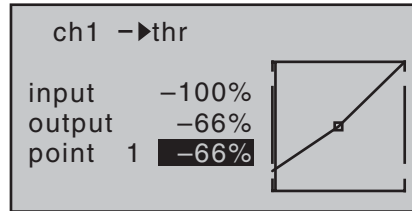

To check that the setting is *exact*, i.e. that there is a seamless transition from idle trim to the throttle curve, you need to close the throttle limiter and move the collective pitch stick to and fro slightly at the minimum end-point. When you do this, the throttle servo must not move! In any case fine-tuning must be carried out with the model flying.

The motor is always started with the throttle limiter completely closed; this has the effect that the idle speed is adjusted solely using the trim lever of the throttle / collective pitch stick.

Throttle limit in conjunction with the digital trim

When used with the throttle limit control CTRL 6, the Ch 1 trim places a marker at the set idle position of the motor; at this point the motor can be stopped using the trim. If the trim is in its *end-range* (see screen-shot: top picture in the right-hand column), then a single click immediately takes you back to the marker, i.e. to the pre-set idle position (see also page 40).

The cut-off trim only acts as idle trim in the *left-hand half* of the travel of the throttle limit control, i.e. the marker is only set and stored within this range.

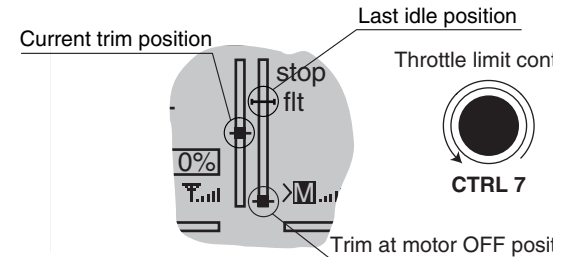

For this reason the Ch 1 trim display is also completely suppressed as soon as the throttle limit control is moved to the right of the centre position.

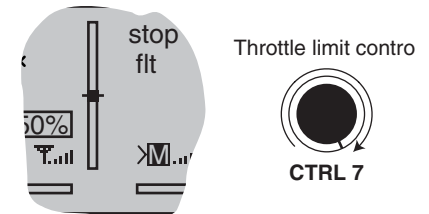

Note:

Since this trim function is only effective in the “Motor off” direction, the illustration above changes if you alter the transmitter control direction for the collective pitch minimum position of the Ch 1 stick from “back” (reflected in the picture above) to “forward” in the “Collective pitch min.” line of the “**Basic settings**” menu. In the same way the effects shown in the illustration swap sides if you change the stick mode from collective pitch right (reflected in the pictures above) to collective pitch left in the “Stick mode” line of the “**Basic settings**” menu; see page 67.

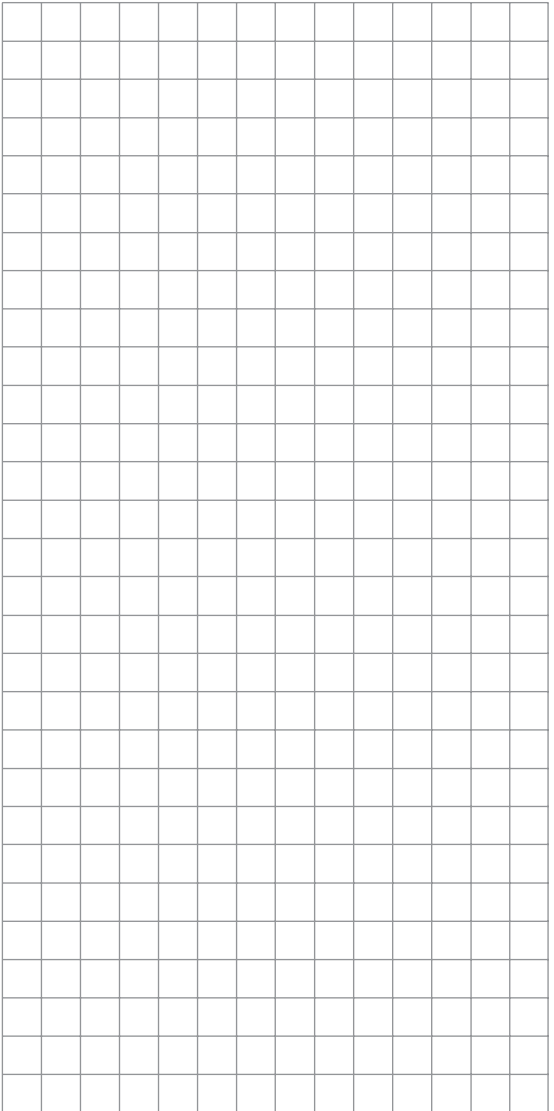
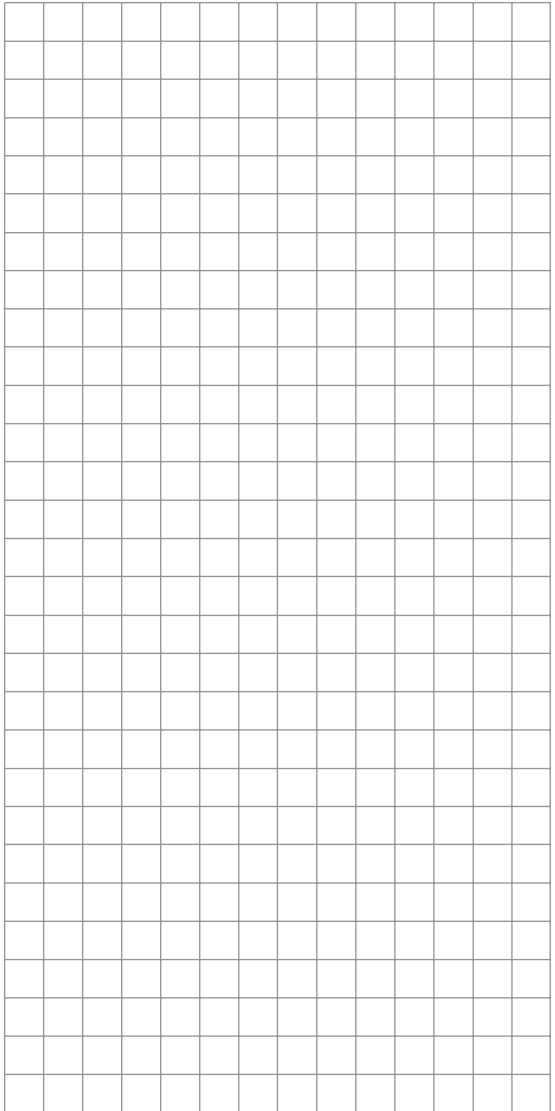
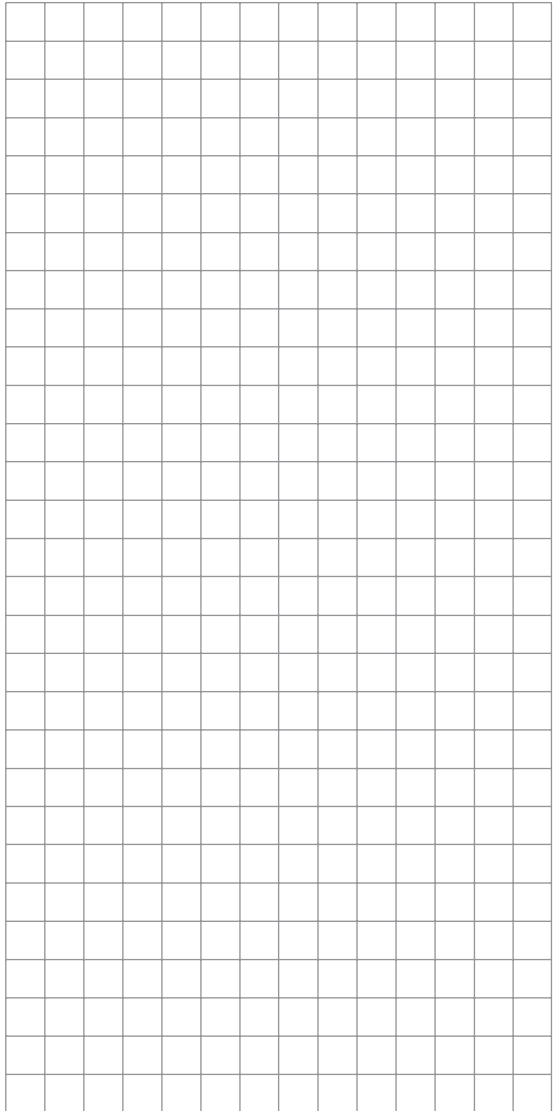

D/R Expo

Switchable control characteristics for aileron, elevator and rudder

Use the arrow buttons of the left or right-hand touch-key to leaf through to the “D/R Expo” menu point of the multi-function menu:

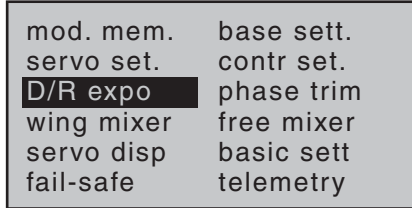

A brief press on the central **SET** button of the right-hand touch-key opens this menu point:

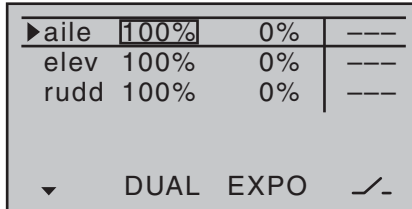

The Dual Rate / Expo function provides a means of switching to reduced control travels, and of influencing the travel characteristics, for aileron, elevator and rudder (control functions 2 ... 4).

Dual Rate works in a similar way to transmitter control travel adjustment in the “Transmitter control settings” menu, i.e. it affects the corresponding *stick function*, regardless of whether that function controls a single servo or multiple servos via any number of complex mixer and coupling functions.

For each switch position the servo travels can be set to any value within the range 0 to 125% of full travel.

Expo works in a different way. If you set a value greater than 0%, exponential provides fine control of the model around the centre position of the primary control func-

tions (aileron, elevator and rudder), without forfeiting full travel at the end-points of stick movement. If you set a value lower than 0%, travel is increased around the neutral position, and diminishes towards the extremes of travel. The degree of “progression” can therefore be set to any value within the range -100% to +100%, where 0% equates to normal, linear control characteristics.

Another application for exponential is to improve the linearity of rotary-output servos, which are the standard nowadays. With a rotary servo the movement of the control surface is inevitably non-linear, as the linear movement of the output disc or lever diminishes progressively as the angular movement increases, i.e. the rate of travel of the control surface declines steadily towards the extremes, dependent upon the position of the linkage point on the output disc or lever. You can compensate for this effect by setting an Expo value greater than 0%, with the result that the angular travel of the output device increases disproportionately as stick travel increases.

Like Dual Rates, the Expo setting applies directly to the corresponding stick function, regardless of whether that function controls a single servo or multiple servos via any number of complex mixer and coupling functions. The Dual Rate and Expo functions can be switched on and off together if you assign a switch to the function. The result of this is that Dual Rates and Expo can be controlled simultaneously using a single switch, and this can be advantageous - especially with high-speed models.

Flight phase dependent Dual-Rate and Expo settings

If you have assigned a switch and - if you wish - a more appropriate name to one of the phases 2 to 4 in the

“Base settings” menu (see page 60), then this appears at bottom left, e.g. “normal”. If necessary, operate the associated switch in order to switch between the flight phases.

The basic set-up procedure

1. Switch to the desired flight phase, and then select the desired line “aile”, “elev” or “rudd” using the arrow buttons ▲ ▼ of the left or right-hand touch-key.
2. If necessary, use the ◀ ▶ buttons of the left or right-hand touch key to select the desired column.
3. Briefly press the central **SET** button of the right-hand touch-key: the corresponding input field is now highlighted (black background).
4. Set the desired value using the arrow buttons of the right-hand touch-key.
5. Touch the central **SET** button of the right-hand touch-key to conclude the input process.
6. Simultaneously press the ▲ ▼ or ◀ ▶ buttons of the right-hand touch-key (**CLEAR**) to reset any changed settings to the default values.

Dual Rate function

If you wish to switch between two possible D/R settings, use the ► button of the left or right-hand touch-key to move to the right-hand column, marked at the bottom edge of the screen with the switch symbol /-, then briefly touch the central **SET** button ...

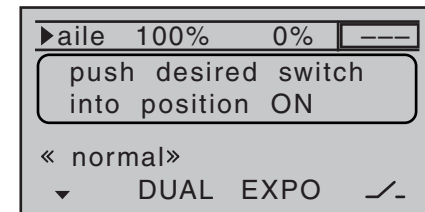

... and assign a physical switch as described in the section "Assigning switches and control switches" on page 39. The assigned switch appears on the screen together with a switch symbol which indicates the direction of operation of the switch. Select the left-hand column, marked DUAL at the bottom edge of the screen, and set the values for each of the two switch positions separately in the highlighted field using the arrow buttons of the right-hand touch-key.

Simultaneously touching the ▲▼ or ◀▶ buttons of the right-hand touch-key (**CLEAR**) resets an altered value in the highlighted field to 100%.

Caution:

For safety reasons the Dual Rate value should always be at least 20% of total control travel.

Examples of different Dual Rate values:

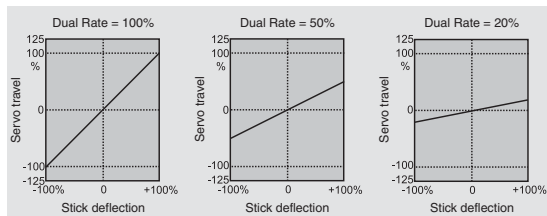

Exponential function

If you wish to switch between two settings, use the ▶ button of the left or right-hand touch-key to move to the right-hand column, marked at the bottom edge of the screen with the switch symbol /_ , then briefly touch the central **SET** button and assign a switch to the function, as described in the section "Assigning switches and control switches" on page 39. The assigned switch appears on the screen together with a switch symbol

which indicates the direction of operation when you move the switch.

For example, the system enables you to fly with a linear curve characteristic in the one switch position, and to pre-set a value other than 0% in the other switch position.

Select the right-hand column, marked with EXPO at the bottom edge of the screen, in order to change the Dual-Rate value for each of the two switch positions in the highlighted field, using the arrow buttons of the right-hand touch-key.

ail	100%	+11%	2
▶elev	100%	+22%	2
rudd	100%	0%	---
◀ normal ▶			
▼ ▲ DUAL EXPO			/_

Simultaneously touching the ▲▼ or ◀▶ buttons of the right-hand touch-key (**CLEAR**) resets an altered value in the highlighted input field to 0%.

Examples of different Expo values:

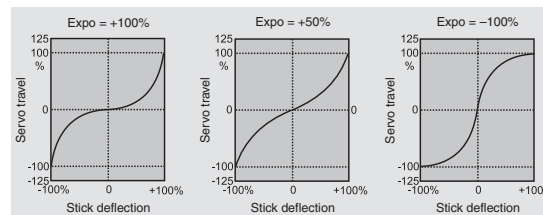

In these examples the Dual Rate value is 100% in each case.

Combined Dual Rate and Expo

If you enter values for both Dual Rates and Expo, the two functions are superimposed as follows:

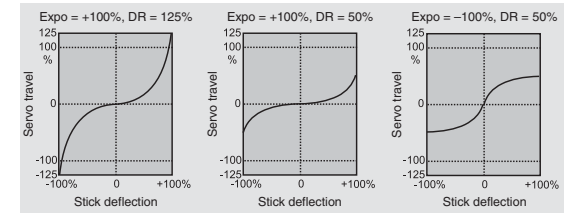

e.g. "switch back":

▶ail	88%	0%	2
elev	77%	0%	2
rudd	100%	0%	---
◀ normal ▶			
▼ ▲ DUAL EXPO			/_

and after moving switch "2" to the "forward" position:

▶ail	122%	+11%	2
elev	111%	+22%	2
rudd	100%	0%	---
◀ normal ▶			
▼ ▲ DUAL EXPO			/_

Switchable control characteristics for roll, pitch-axis and tail rotor

▶roll	100%	0%	---
nick	100%	0%	---
tail	100%	0%	---
▼ DUAL EXPO			↙

The Dual Rate / Expo function provides a means of switching to reduced control travels, and influencing the travel characteristics, for the roll, pitch-axis and tail rotor servos (control functions 2 ... 4).

A separate curve for control function 1 (motor / collective pitch) can be set individually for throttle, collective pitch and tail rotor in the **“Helicopter mixers”** menu. These curves feature up to five separately programmable points; see the sections starting on page 94 and 167.

Dual Rate works in a similar way to transmitter control travel adjustment in the **“Transmitter control settings”** menu, i.e. it affects the corresponding stick function, regardless of whether that function controls a single servo or multiple servos via any number of complex mixer and coupling functions.

For each switch position the servo travels can be set to any value within the range 0 to 125% of full travel.

Expo works in a different way. If you set a value greater than 0%, exponential provides fine control of the model around the centre position of the primary control functions (roll, pitch-axis and tail rotor), without forfeiting full travel at the end-points of stick movement. If you set a value lower than 0%, travel is increased around the neutral position, and diminishes towards the extremes of travel. The degree of “progression” can be set within the range -100% to +100%, where 0% equates to normal, linear control characteristics.

Another application for exponential is to improve the linearity of rotary-output servos, which are the standard nowadays. With a rotary servo the movement of the control surface is inevitably non-linear, as the linear movement of the output disc or lever diminishes progressively as the angular movement increases, i.e. the rate of travel of the control surface declines steadily towards the extremes, dependent upon the position of the linkage point on the output disc or lever. You can compensate for this effect by setting an Expo value greater than 0%, with the result that the angular travel of the output device increases disproportionately as stick travel increases.

Like Dual Rates, the Expo setting applies directly to the corresponding stick function, regardless of whether that function controls a single servo or multiple servos via any number of complex mixer and coupling functions. The Dual Rate and Expo functions can also be switched on and off together if you assign a switch to the function. The result of this is that Dual Rates and Expo can be controlled simultaneously using a single switch, and this can be advantageous - especially with high-speed models.

Flight phase dependent Dual-Rate and Expo settings

If you have assigned a switch and - if you wish - a more appropriate name to one of the phases 2, 3 or Auto-rotation in the **“Basic settings”** menu (see page 68 and 69), then this appears at bottom left, e.g. “normal”. If necessary, operate the associated switch in order to switch between the flight phases.

The basic set-up procedure

1. Switch to the desired flight phase, and then select

the desired line “Roll”, “Pitch” or “Tail” using the arrow buttons ▲ ▼ of the left or right-hand touch-key.

2. If necessary, use the ◀ ▶ buttons of the left or right-hand touch key to select the desired column.
3. Briefly press the central **SET** button of the right-hand touch-key: the corresponding input field is now highlighted (black background).
4. Set the desired value using the arrow buttons of the right-hand touch-key.
5. Touch the central **SET** button of the right-hand touch-key to conclude the input process.
6. Simultaneously press the ▲ ▼ or ◀ ▶ buttons of the right-hand touch key (**CLEAR**) to reset any changed settings to the default values.

Dual Rate function

If you wish to switch between two possible D/R settings, use the ▶ button of the left or right-hand touch-key to move to the right-hand column, marked at the bottom edge of the screen with the switch symbol ↙, briefly touch the central **SET** button ...

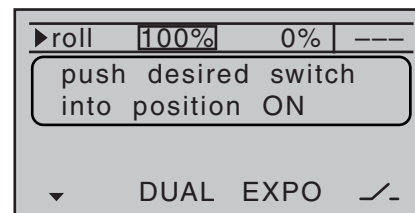

... and assign a physical switch as described in the section “Assigning switches and control switches” on page 39. The assigned switch appears on the screen together with a switch symbol which indicates the direction of operation of the switch.

Select the left-hand column, marked DUAL at the bottom

edge of the screen, and set the values for each of the two switch positions separately in the highlighted field using the arrow buttons ▲▼ or ◀▶ of the right-hand touch-key.

Simultaneously press the ▲▼ or ◀▶ buttons of the right-hand touch key (**CLEAR**) resets an altered value in the highlighted field to 100%.

Caution:

For safety reasons the Dual Rate value should always be at least 20% of total control travel.

Examples of different Dual Rate values:

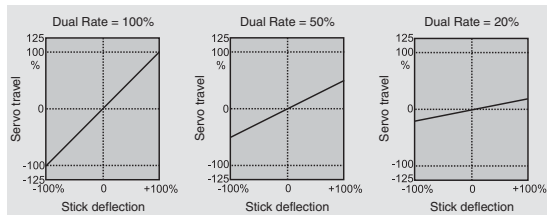

Exponential function

If you wish to switch between two settings, use the ▶ button of the left or right-hand touch-key to move to the right-hand column, marked at the bottom edge of the screen with the switch symbol ↗, then briefly touch the central **SET** button and assign a switch to the function, as described in the section "Assigning switches and control switches" on page 39. The assigned switch appears on the screen together with a switch symbol which indicates the direction of operation when you move the switch.

For example, the system enables you to fly with a linear curve characteristic in the one switch position, and to pre-set a value other than 0% in the other switch position.

tion.

Select the right-hand column, marked with EXPO at the bottom edge of the screen, in order to change the Dual-Rate value for each of the two switch positions in the highlighted field, using the arrow buttons of the right-hand touch-key.

roll	100%	+11%	2
▶nick	100%	+22%	2
tail	100%	0%	---

« normal »
 ▼ ▲ DUAL EXPO ↗

Simultaneously touching the ▲▼ or ◀▶ buttons of the right-hand touch-key (**CLEAR**) resets an altered value in the highlighted input field to 0%.

Examples of different Expo values:

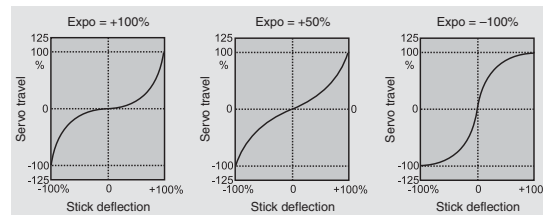

In these examples the Dual Rate value is 100% in each case.

Combined Dual Rate and Expo

If you enter values for both Dual Rates and Expo, the two functions are superimposed as follows:

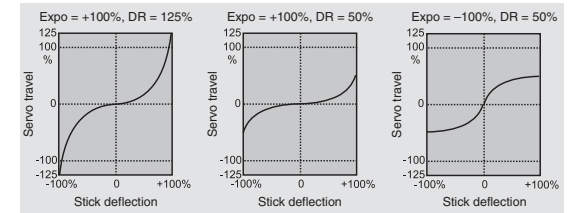

e.g. "switch back":

▶roll	88%	0%	2
nick	77%	0%	2
tail	100%	0%	---

« normal »
 ▼ DUAL EXPO ↗

and after moving switch "2" to the "forward" position:

▶roll	122%	+11%	2
nick	111%	+22%	2
tail	100%	0%	---

« normal »
 ▼ DUAL EXPO ↗

Phase trim

Flight phase-specific trims for flaps, ailerons and elevator

If you have not assigned a switch to phases 2, 3 and 4 in the **“Basic settings”** menu, i.e. you have not assigned switches to these alternative phases, you automatically remain in flight phase 1 - “normal”.

The number and name (“normal”) of this flight phase are permanently assigned, and cannot be altered. For this reason the “normal” phase is not stated as Phase 1 “normal” in the **“Basic settings”** menu; it is simply concealed.

aile/flap		2aile
timer	10:01	2↕
phase 2	takeoff	---
phase 3	speed	---
▶ phase 4	land[ing]	---
▼▲		↔

If you select the **“Phase trim”** menu with this basic arrangement, you will find just the “normal” line on the screen, whose pre-set values of 0% are not usually altered.

P H A S E T R I M			
*normal	0%	0%	0%
FLA AIL ELE			

Note:

In this menu you will have at least one control function (ELE), and a maximum of three functions (ELE, AIL and FLA), available for phase-specific trim settings, depending on the settings you have entered in the “Aileron / flap” line of the **“Basic settings”** menu (see page 58).

If you wish to enter values other than “0”, e.g. to have more lift at launch, or to be able to fly more slowly when thermalling, or faster when flying speed tasks, but WITHOUT having to change the basic settings each time, then you need to use alternative flight phases.

This is done by activating “Phase 2” and, if necessary, “Phase 3” in the **“Basic settings”** menu. You might then use “Phase 4” for the “thermal” settings.

This is accomplished by moving to the **“Basic settings”** menu and assigning a switch to the selected phase or phases. If you decide to use one of the three-position switches SW 4/5 or 6/7 as the phase switch, then it is advisable to assign it to the “Speed” phase and “Landing” phase at the extremes, with “normal” at the centre position. In our example phase 2 contains the “Launch” settings, and since this has top priority, you can shift to this phase from any other phase using a two-position switch.

Notes:

- At the centre position of SW 4/5 or 6/7 the switch symbols on the screen should look as in the picture at top right.
- Please note the priorities of the individual flight phases, as described in detail on page 60.

The default name for “Phase 2” is “take off”, that for “Phase 3” is “speed”, and that for “Phase 4” is “landing”. However, you can assign your own choice of names at any time by selecting the appropriate line, pressing the central **SET** button of the right-hand touch-key, and selecting one of the following names in the highlighted field using the arrow buttons of the right-hand touch-key.

- take off
- thermal

- dist(ance)
- speed
- acro
- landing
- air-tow
- test

timer	10:01	2↕
phase 2	takeoff	2↕
phase 3	speed	7↕
▶ phase 4	ther[mal]	6↕
receiv out		=>
▼▲		↔

These names will appear in the transmitter’s basic display ...

GRAUBELE	stop	0:00
#01	flt	0:00
5.2V	<<normal >>	HoTT
2:22h	>M	5.5V

... and in the **“Phase trim”** menu - see lower picture.

Setting up flight phase trims

In the “Phase trim” menu you can adjust the trims for the previously selected flight phases.

The first step is to use the phase switch you have already assigned to move to the phase which you wish to adjust (the “*” at far left indicates the currently active phase).

P H A S E T R I M			
*normal	0%	0%	0%
takeoff	0%	0%	0%
speed	0%	0%	0%
thermal	0%	0%	0%
	FLA	AIL	ELE

Select the desired control surface function using the arrow buttons ◀ ▶ of the left or right-hand touch-key, then briefly press the central **SET** button of the right-hand touch-key. The trim values in the highlighted value field can now be adjusted using the arrow-buttons of the right-hand touch-key.

You can activate each phase by operating the assigned phase select switch or switches. Note that the servos do not change from one setting to another abruptly; they move smoothly with a transition time of around one second.

With this option, which works in a similar way to transmitter control sub-trim or offset settings with other radio control systems, it is possible to set values within the range -99% to +99%. However, typical values are normally in single figures or low double figures.

P H A S E T R I M			
normal	0%	0%	0%
takeoff	+8%	4%	+2%
speed	-7%	-5%	-3%
*thermal	+10%	+5%	+2%
	FLA	AIL	ELE

If you have made any changes, simultaneously pressing the ▲ ▼ or ◀ ▶ buttons of the right-hand touch-key (**CLEAR**) resets them to the default value of 0%.

Note:

In this menu you will have at least one control function (ELE), and a maximum of three functions (ELE, AIL and FLA), available for phase-specific trim settings, depending on the settings you have entered in the "Aileron / flap" line of the **"Basic settings"** menu (see page 58).

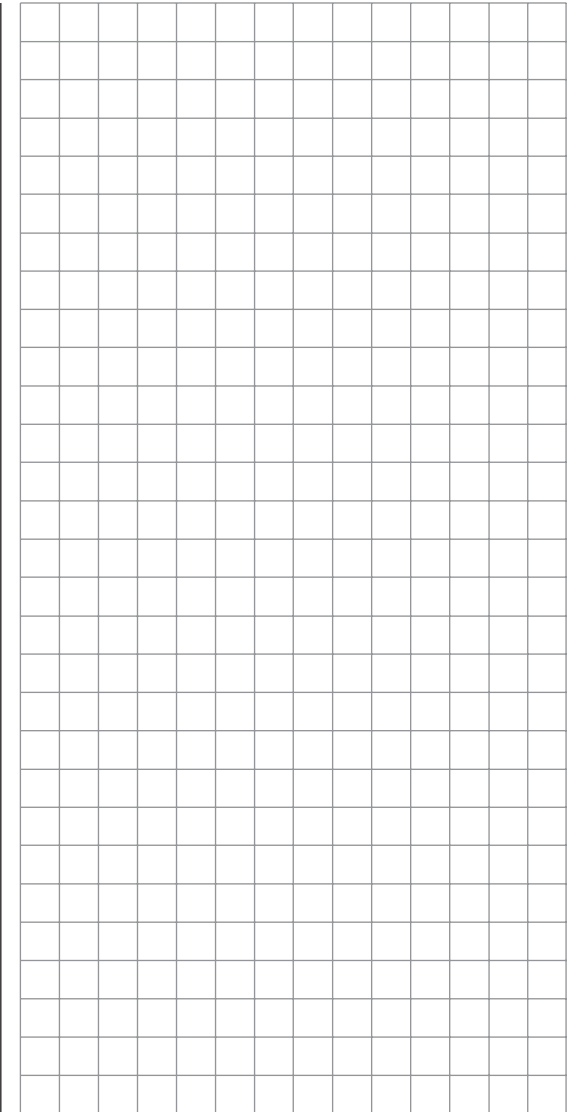

What is a mixer?

The basic function

In many models it is often desirable to use a mixer to couple various control systems, e.g. to link the ailerons and rudder, or to inter-connect a pair of servos where two control surfaces are actuated by separate servos. In all these cases the signal which flows directly from the “output” of a transmitter stick to the associated servo is “bled off” at a particular point - this effect can also be “concealed” in transmitter control options such as “D/R Expo” or “Transmitter control settings” - and the derived signal is then processed in such a way that it affects the “input” of another control channel, and therefore eventually another receiver output.

Example: V-tail mixer

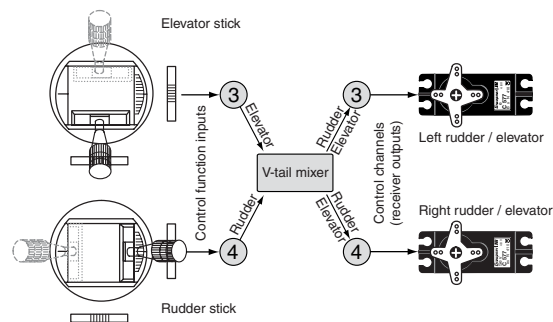

The **mx-16** HoTT transmitter software contains a large number of pre-programmed coupling functions as standard, designed to mix together two (or more) control channels. The mixer required in this example is supplied “ready-made” in the software, and just has to be activated in the “tail” line of the “Basic settings” menu in the form of “V-tail”.

The software also includes three freely programmable linear mixers in the fixed-wing and helicopter programs, all of which can be used in each model memory.

For more information please refer to the general notes on “Free mixers” in the section of this manual starting on page 106.

Fixed-wing mixers

▶diff aile.	0%	----
diff flaps	0%	----
ail-→rudd	0%	----
ail-→flaps	0%	----
brak-→elev	0%	----
brak-→flap	0%	----
brak-→aile	0%	----
elev-→flap	0%	----
elev-→aile	0%	----
flap-→elev	0%	----
flap-→aile	0%	----
diff-red	0%	----

(The display varies according to the information you have entered in the “Motor at Ch 1” and “Ail / Flap” lines in the “Basic settings” menu. The selection above shows the maximum number of options, and equates to the setting “No (motor)” and “2AIL 2FL”).

The **mx-16** HoTT transmitter’s program contains a series of pre-programmed coupling functions, and all you have to do is set the mixer ratios and (optionally) assign a switch. The number of pre-programmed mixer functions in the mixer list will vary according to the pre-set “model type” (tail type, number of wing servos, with or without motor - see the section starting on page 56). For example, if your model is not fitted with camber-changing flaps, and you have not entered any flap servos in the “Basic settings” menu, the software automatically suppresses all the flap mixers, as are the “Brake → NN” mixers if you enter “Idle forward” or “Idle back” in the “Motor at Ch 1” line. This makes the menus clearer and easier to understand, and also avoids potential programming errors.

* NN = Nomen Nominandum (name to be stated)

Notes:

- There are various alternative methods of positioning the camber-changing flaps; these include:
 - a) settling on just one position per flight phase, simply by setting appropriate trim values in the **“Phase trim”** menu, as described on the preceding double-page;
 - b) controlling the flaps manually using any transmitter control assigned to “Input 6” (in the **“Transmitter control settings”** menu - see page 74), after setting the basic flap positions in the **“Phase trim”** menu, as described earlier. Ideally the transmitter control would be one of the rotary proportional controls CTRL 6 ... 8.

The selected transmitter control directly operates the two flap servos connected to receiver outputs 6 and 7, assuming that you have specified flaps in the “Ail. / Flap” line of the **“Basic settings”** menu. The same control determines the flap setting of the ailerons via the percentage value entered in the “FL → AIL” mixer line.

However, for finer control of the flap positions, we recommend that you reduce their travel to about 25% in the “E6” line of the **“Transmitter control settings”** menu.
 - c) It is also possible to leave the default setting of “0%” in the appropriate line of the “FL → AIL” menu, and to assign the same transmitter control to both input 6 and input 5 in the **“Transmitter control settings”** menu. The magnitude of the effect on the two pairs of wing flaps can then be adjusted using the servo travel adjustment facility.
- If a transmitter control is assigned to input “7”, it will be de-coupled by the software if two camber-chang-

ing flaps are defined; this is intentional, as it eliminates the danger of errors when a flap command is given.

The basic programming procedure

1. Use the ▲ ▼ buttons of the left or right-hand touch-key to select the desired mixer.
2. Use the ► button of the left or right-hand touch-key to move to the right-hand column, marked by the switch symbol  at the bottom edge of the screen.
3. Touch the central **SET** button of the right-hand touch-key; the corresponding input field is now highlighted (black background).
4. Use the arrow buttons of the right-hand touch-key to set the desired value, and assign the switch if necessary, as described on page 39.

With the exception of the “Diff. red.” line, negative and positive parameter values are possible; this may be necessary to obtain the correct direction of servo rotation (control surface deflection).

Simultaneously pressing the ▲ ▼ or ◀ ▶ buttons of the right-hand touch-key (**CLEAR**) resets an altered value to the default value.
5. Touch the central **SET** button of the right-hand touch-key to conclude the input process.

Mixer neutral point (offset)

The neutral point of the mixers ...

Aileron → NN *
Elevator → NN *
Elevator → NN *

... is by default the zero point of the transmitter control, i.e. that is the point at which they have no effect. At the

* NN = Nomen Nominandum (name to be stated)

end-point of the transmitter control the full mixer value is applied.

The default neutral point (“offset”) of the mixers ...

Airbrake → NN *

... at which the airbrakes are *always retracted*, is the forward position of the Ch 1 stick (throttle / airbrakes) if you select “none” in the “Motor at Ch 1” line of the **“Basic settings”** menu, and is the back position of the Ch 1 stick if you select “none/inv”.

diff aile (differential aileron travel)

Aileron differential compensates for an unwanted side-effect which occurs when ailerons are deflected: the problem known as “adverse yaw”. When ailerons are deflected, the drag generated by the down-going aileron is greater than that produced by the up-going aileron. The differential drag causes a yawing motion around the vertical axis in the opposite direction to the desired turn. This effect is much more pronounced in model gliders with high aspect ratio wings than in power models with their much shorter moment arms, and usually has to be countered by giving a simultaneous rudder deflection in the opposite direction to the yaw. However, this in turns causes additional drag and reduces the aircraft’s efficiency even further.

Aileron differential reduces the angular travel of the down-going aileron relative to the up-going aileron, and this reduces the drag and therefore the adverse yaw. However, electronic differential can only be applied if each aileron is actuated by its own servo, usually mounted in the wings themselves. The shorter pushrods also result in virtually slop-free aileron linkages with reliable centring.

Mechanical solutions are also possible, but they usually

have to be “designed in” when the model is built, and the degree of differential cannot be altered subsequently. In any case significant mechanical differential tends to cause additional slop in the control system. Electronic differential offers several important advantages:

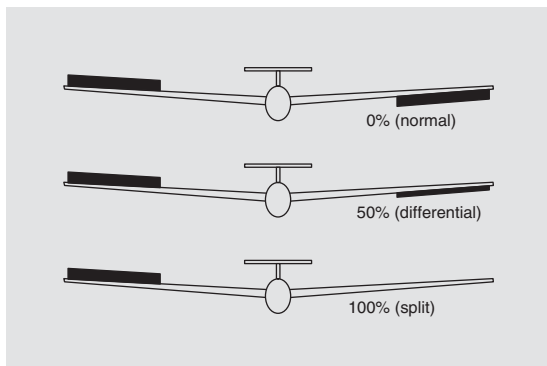

It is easily possible to vary the degree of differential without affecting the travel of the up-going aileron. At one extreme it is possible to suppress the down-aileron deflection completely, i.e. only the up-going aileron moves at all, and this arrangement is sometimes called the “split” setting. Split ailerons not only tend to suppress adverse yaw, but can even generate positive yaw, which means that the model yaws in the direction of the turn when an aileron command is given. In the case of large model gliders, smooth turns can then be flown using ailerons alone, which with most models of this type is usually by no means the case.

The adjustment range of -100% to +100% makes it possible to set the correct direction of differential regardless of the direction of rotation of the aileron servos. “0%” corresponds to a normal linkage, i.e. no differential, while “-100%” or “+100%” represents the “split” function.

For aerobatic flying it is necessary to set low absolute differential values, to ensure that the model rotates exactly along its longitudinal axis when an aileron command is given. Moderate values around -50% or +50% are typical for making thermal turns easier to fly. The split setting (-100%, +100%) is popular with slope flyers, when ailerons alone are often used for turning the model.

Simultaneously pressing the ▲▼ or ◀▶ buttons of the right-hand touch-key (**CLEAR**) resets an altered value to 0%.

Note:

Although it is possible to enter negative values in order to reverse the direction of servo rotation, this is not usually necessary if the correct channels are used.

diff flaps (Camber-changing flap differential)

The aileron / flap mixer (see below) is designed to superimpose an aileron function on the flaps. Flap differential works like aileron differential, and produces a reduced flap movement in the down-direction when these surfaces are used as supplementary ailerons.

The adjustment range of -100% to +100% makes it possible to set the correct direction of differential regardless of the direction of rotation of the servo. “0%” corresponds to a normal linkage, i.e. the servo travel is the same up and down. A setting of “-100%” or “+100%” means that the down-travel of the flaps is reduced to zero when an aileron command is given (“split” setting). Simultaneously pressing the ▲▼ or ◀▶ buttons of the right-hand touch-key (**CLEAR**) resets an altered value to 0%.

Note:

Negative values are not usually necessary if the correct channels are used.

ail → rudd (Aileron → rudder)

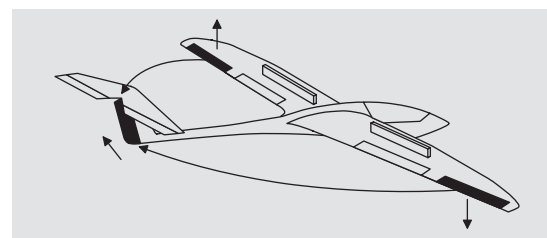

In this case the rudder automatically “follows” when an aileron command is given, and the mixer ratio (degree of following) can be set by the user. Coupled aileron / rudder (also known as “combi-switch”) is especially useful for suppressing adverse yaw in conjunction with aileron differential, and this combination usually makes smooth turns very easy to fly. Naturally, the rudder can still be controlled separately by means of its dedicated stick.

The adjustment range of +/- 150% enables the user to set up the correct direction of travel according to the direction of rotation of the flap servos. If an (optional) non-centring switch (SW 2 ... 8) is assigned to this function, the mixer can be turned on and off in flight, so that you can control the ailerons and rudder separately if and when you so desire.

Simultaneously pressing the ▲▼ or ◀▶ buttons of the right-hand touch-key (**CLEAR**) resets an altered value to 0%.

This mixer is usually set up in such a way that the rudder deflects automatically to the side of the up-going aileron; a setting around 50% is likely to be approximately correct.

ail → flaps

(Aileron → flap)

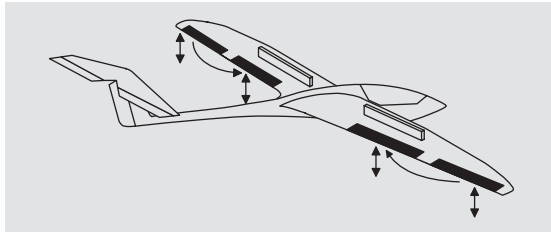

This mixer feeds a variable amount of the aileron signal into the flap channel. When an aileron command is given, the flaps “follow” the ailerons, although usually through a smaller angle, i.e. the mixer ratio is generally less than 100%. The adjustment range of -150% to +150% allows the user to set up the flap direction to match that of the ailerons.

The flaps should not deflect more than about 50% of the (mechanical) travel of the ailerons.

Simultaneously pressing the ▲▼ or ◀▶ buttons of the right-hand touch-key (**CLEAR**) resets an altered value to 0%.

Note:

If your model is equipped with only one flap servo, you should still select “2FL” in the “**ail/flap**” line of the “**Basic settings**” menu (see page 58) but leave the “**Ail → Flap**” mixer at 0%. In contrast, all the other wing mixers can be used in the usual way.

brak → elev

(Airbrake → elevator)

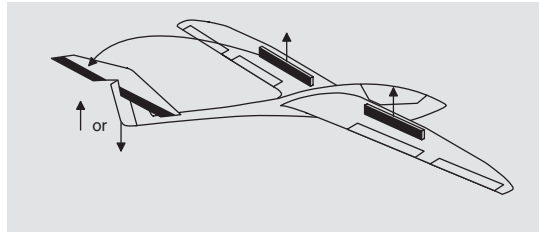

Extending any form of airbrakes usually generates an unwanted change in airspeed; this is especially marked when a butterfly (crow) braking system is deployed (see next page).

This mixer feeds a corrective signal to the elevator to compensate for such an effect. The adjustment range is -150% to +150%.

Simultaneously pressing the ▲▼ or ◀▶ buttons of the right-hand touch-key (**CLEAR**) resets an altered value to 0%.

“Usual” values are generally in single to low double figures. It is essential to check and adjust this setting at a safe height, and it is also important to ensure that the model does not slow down too much when the airbrakes are extended. The danger is that you might need to retract the brakes again on the landing approach when you realise the model will “land short”; if its airspeed is too low when you retract the brakes, the model will just fall to the ground at that point.

brak → flap

(Airbrake → flap)

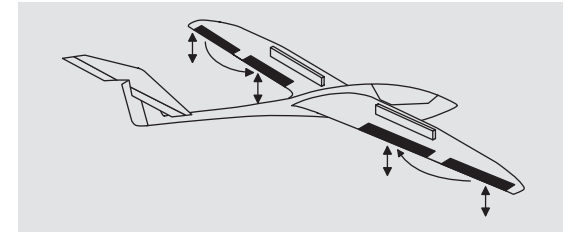

When you operate the brake function (Ch 1 stick), both flap servos move together for the landing approach; the mixer ratio can be set to any value in the range -150% to +150%. Down-flap is usually selected.

Simultaneously pressing the ▲▼ or ◀▶ buttons of the right-hand touch-key (**CLEAR**) resets an altered value to 0%.

At this point you select the value which causes the flaps to deflect down as far as possible when the airbrake function is deployed. However, please ensure that none of the servos concerned strikes its mechanical end-stops (servos stalled). To achieve this, you may need to limit the servo travel(s) using the “Travel +/-” option, which is found on the “RX SERVO” display page of the “**Telemetry**” menu.

brak → aile

(Airbrake → aileron)

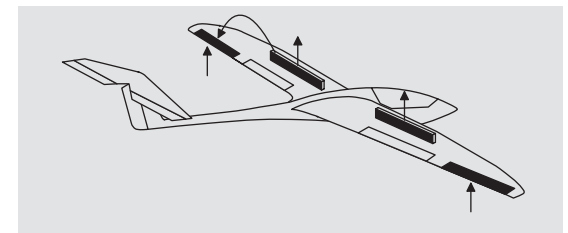

When you operate the brake function, both aileron

servos move together for the landing approach; the mixer ratio can be set to any value in the range -150% to +150%.

Simultaneously pressing the ▲▼ or ◀▶ buttons of the right-hand touch-key (**CLEAR**) resets an altered value to 0%.

Note:

It can also be useful to deflect both ailerons up slightly when the airbrakes are extended; in most cases this significantly reduces the risk of a tip-stall.

Combination of the “Brake → NN *” mixers: “Crow” or “Butterfly” setting

If you have set up all three airbrake mixers for your model, it is then possible to program a special configuration known as the “crow” or “butterfly” arrangement for glide path control. In the butterfly setting *both ailerons are deflected up by a moderate amount, and both flaps down by the maximum possible amount.* The third mixer provides elevator trim to counteract any unwanted pitch trim change and maintain the model’s airspeed at a safe level. This is necessary to avoid the danger of the model slowing up excessively; if the landing approach is started too soon, and has to be extended by retracting the airbrakes again, the model could then stall abruptly.

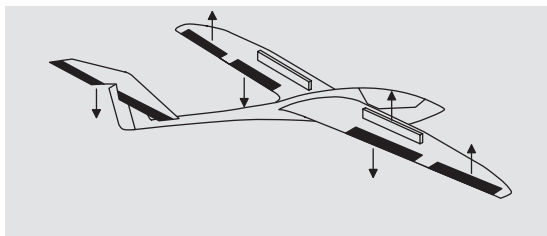

This inter-action between the flaps, ailerons and elevator is used to control the glide angle on the landing approach. Optionally the butterfly setting can also be used without the airbrakes or spoilers; nowadays this is very commonly used for sports and competition aircraft.

Note:

If your model features full-span (strip) ailerons which also double as camber-changing flaps, the two mixers “Brake → aileron” and “Brake → elevator” can be combined for glide path control. In this case up-flap is applied, but the flaps can still be controlled as ailerons. Elevator pitch trim compensation is generally required.

If you have programmed aileron differential, the response of the ailerons will inevitably be adversely affected by the extreme “up” deflection of the ailerons in the butterfly setting, because the differential travel reduces or entirely suppresses the down-aileron deflection. However, the “up” travel of the ailerons is also greatly restricted because they are already at or close to their “up” end-point. The remedy here is to apply “differential reduction”, which is explained in its own section later.

elev → flap (Elevator → flap)

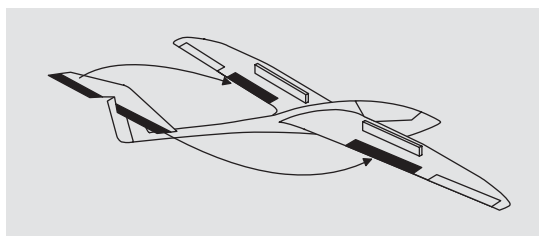

The flaps can be used to enhance the effect of the elevator in tight turns and aerobatics, and this mixer feeds

part of the elevator signal to the flap servos. The mixer direction must be set so that the flaps move down when up-elevator is applied, and vice versa.

Simultaneously pressing the ▲▼ or ◀▶ buttons of the right-hand touch-key (**CLEAR**) resets an altered value to 0%.

The “usual” settings for this mixer are in the low two-digit range.

elev → aile (Elevator → aileron)

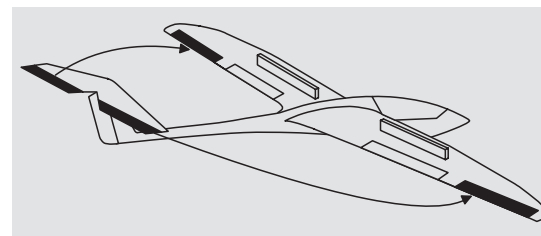

This mixer allows the ailerons to reinforce the elevator response in the same way as the previous mixer.

Simultaneously pressing the ▲▼ or ◀▶ buttons of the right-hand touch-key (**CLEAR**) resets an altered value to 0%.

The adjustment range is +/- 150%. For this mixer the “usual” settings are again in the low two-digit range.

flap → elev (Flap → elevator)

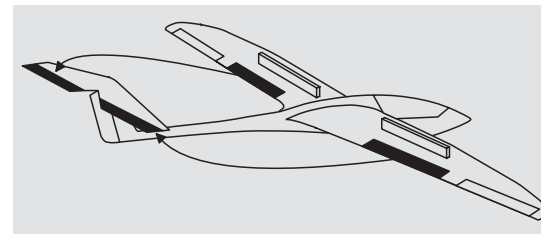

* NN = Nomen Nominandum (name to be stated)

When the camber-changing flaps are lowered, either using “Phase trim” or by means of a transmitter control assigned to input “6”, a pitch trim change (up or down) may occur. Alternatively it may be desirable for slight down-elevator to be applied automatically when the flaps are raised by a small amount, in order to increase the model’s basic airspeed. This mixer can be used to achieve both purposes.

When the flaps are deployed, this mixer causes the elevator setting to be corrected automatically in proportion to the flap deflection.

The adjustment range is +/- 150%. For this mixer the “usual” settings are in the single to low two-digit range.

Simultaneously pressing the ▲▼ or ◀▶ buttons of the right-hand touch-key (**CLEAR**) resets an altered value to 0%.

flap → aile (Flap → aileron)

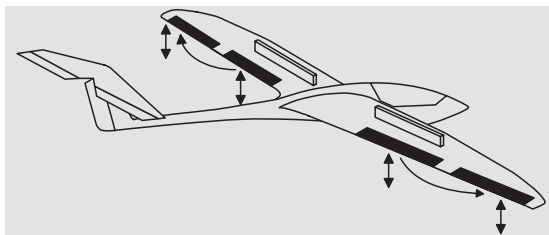

This mixer causes a variable proportion of the flap signal to be mixed in with the aileron channels 2 and 5 so that the ailerons follow the movement of the flaps, albeit normally with a smaller deflection.

The adjustment range is +/- 150%. For this mixer the “usual” settings are around 50%.

Simultaneously pressing the ▲▼ or ◀▶ buttons of the right-hand touch-key (**CLEAR**) resets an altered value to 0%.

Note:

If you assign a transmitter control to inputs 5 and 6 in the “Transmitter control settings” menu for adjusting the flap positions, then you should leave the value for this mixer at 0%. See the notes on page 89 in this regard.

diff red (Differential reduction)

The problem of reduced aileron response in the butterfly configuration has been mentioned earlier: if aileron differential is employed, the aileron response on the landing approach may be adversely affected through the extreme “up” deflection of the ailerons, permitting virtually no further up-movement; on the other hand the “down” travel has already been reduced by the programmed differential setting. The overall result is significantly reduced aileron response compared with the normal setting of the control surfaces.

In this case you really should use “differential reduction” if at all possible. This reduces the degree of aileron differential when you invoke the butterfly setting using the airbrake stick. Differential is reduced progressively, or even eliminated altogether, as the airbrake stick is moved towards its end-point.

A value of 0% at this point means that the full programmed aileron differential is retained. A value of 100% means that the aileron differential is completely eliminated at the *maximum* butterfly setting, i.e. when the airbrakes and other glide path control surfaces are fully extended. If you set a value above 100%, the aileron differential is eliminated even before full travel of the airbrake stick is reached.

The adjustment range is 0 to 150%.

Simultaneously pressing the ▲▼ or ◀▶ buttons of the

right-hand touch-key (**CLEAR**) resets an altered value to 0%.



Helicopter mixers

Flight phase-specific mixers for collective pitch, throttle and tail rotor

In the “**Basic settings**” menu a method of switching flight phases can be activated by assigning the appropriate switches to “Phase 2”, “Phase 3” and “Auto-rotation”. You can then switch between the phases “normal” and a second and third phase - to which you can assign more appropriate names yourself, if necessary - using one of the non-centring switches SW 2 ... 8; a further switch then selects “Auto-rotation”. **However, “Phase 2” always has precedence over the other two phases; see pages 68 / 69.**

If you have not yet assigned switches for the flight phases, you should do so now. Use the arrow buttons of the left-hand touch-key to move to the right-hand column, marked by the switch symbol at the bottom of the screen, then touch the central **SET** button of the right-hand touch-key. The switches are assigned as described on page 39:

pitch min		rear
timer	10:01	C3\
phase 2	hover	5\
phase 3	speed	4\
▶autorotat.		2\

Phase 1 always bears the designation “normal”. Both the number and name of this phase are permanently assigned, and cannot be altered. For this reason the “normal” phase is not stated as Phase 1 in the “**Basic settings**” menu; it is simply concealed.

By default “Phase 2” is assigned the phase name “hover”, and “Phase 3” the name “speed”, but you can change these at any time if you prefer: touch the central **SET** button with the right-hand touch-key, and use the arrow buttons of the right-hand touch-key to select one

of the following names:

- hover
- acro
- acro 3D
- speed
- test

Description of the helicopter mixers

Five-point curves are available for setting up the control characteristics of “collective pitch”, “Ch 1 → throttle” and “Ch 1 → tail rotor”. Using these curves it is possible to program non-linear mixer ratios along the travel of the transmitter stick for these mixers. Move to the display page for setting 5-point curves by touching the central **SET** button of the right-hand touch-key (see below).

In contrast, the mixers “Ch 1 → throttle” and “Ch 1 → tail rotor” are not required for the “Auto-rotation” flight phase (described in the section starting on page 104); instead they are automatically switched to a (user-variable) pre-defined value.

A value must be entered in the “Gyro” and “Input 8” lines: touch the central **SET** button of the right-hand touch-key, then enter a value in the highlighted field using the arrow buttons of the right-hand touch key - in a similar fashion to changing the transmitter centre position or the offset position with other radio control systems. This set-up facility is rounded off with the “Swashplate limit” option: this restricts the maximum travel of the swashplate servos to the value you set, in the form of a limiter. All these options are required for the basic process of setting up a model helicopter.

Altered parameters can be reset to the corresponding default values at any time by simultaneously pressing the or buttons of the right-hand touch-key

(**CLEAR**).

The name of the currently selected flight phase is displayed in the “**Helicopter mixers**” menu as well as in the transmitter’s basic display; this is designed to ensure that any changes you make actually apply to the appropriate flight phase. Note that the servos do not change from one setting to another abruptly; they move smoothly with a transition time of around one second. This does not apply to auto-rotation: when you switch INTO auto-rotation, the change takes place immediately. If you operate the switch selected for a particular flight phase, the associated flight phase is superimposed at the left-hand bottom edge of the screen, e.g. “normal”.

▶ptch		=>
ch1	▶thro	=>
ch1	▶tail	=>
gyro	0%	
inp8	0%	
◀normal	»	

Now you can program the settings for this flight phase.

Basic programming procedure

1. Use the arrow buttons of the left or right-hand touch-key to select the desired option.
2. Touch the central **SET** button of the right-hand touch-key, and the screen switches to the set-up page (symbol at the bottom edge of the screen), or the corresponding input field is highlighted (black background).
3. Define the mixer values using the arrow buttons of the right-hand touch-key, moving the throttle / collective pitch stick at the same time if necessary.
4. Simultaneously pressing the or buttons of

the right-hand touch-key (**CLEAR**) resets an altered value to the default value.

5. Touch the central **SET** button of the right-hand touch-key to conclude the input process.

ptch (Collective pitch (ch1 → pitch))

Select the “Collective pitch” line using the arrow buttons ▲ ▼ of the left or right-hand touch key, then touch the central **SET** button of the right-hand touch-key:

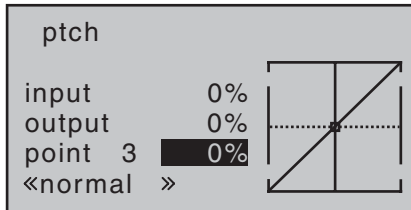

The control curve can be based on a maximum of five nodes, known as “reference points”, which can be placed along the length of the control travel; separate curves can be programmed for each flight phase.

However, in most cases it is sufficient to use a smaller number of reference points when defining the collective pitch curve. As a basic rule we recommend that you start with the three default reference points offered by the software. These three points, i.e. the two end-points “Point 1” (collective pitch minimum) and “Point 5” (collective pitch maximum), and “Point 3”, exactly in the centre of the travel, initially describe a linear characteristic for the collective pitch curve; this is represented in the picture above.

The programming procedure in detail

The throttle / collective pitch stick can now be used to move the vertical line in the graph between the two end-points “Point 1” and “Point 5”; at the same time the momentary position of the stick is displayed in numeric form in the “Input” line (-100% to +100%).

The point where the vertical line crosses the curve is termed the “Output”, and this point can be varied within the range -125% and +125% at a maximum of five reference points. The control signal, modified in this way, affects the collective pitch servos only. In the picture on the left the stick is exactly at the 0% position at “Point 3”, and also generates an output signal of 0% due to the linear nature of the graph.

By default only points “1” (collective pitch minimum at -100%), “3” (hover point at 0%) and “5” (collective pitch maximum at +100% travel) are active.

To set a point you use the associated stick to move the vertical line to the point you wish to change. The number and current curve value of this point are displayed in the bottom line in the left-hand half of the screen in the “Point” line. The arrow buttons of the right-hand touch-key can now be used to change the current curve value in the highlighted field to any value within the range -125% to +125%, without affecting the adjacent points.

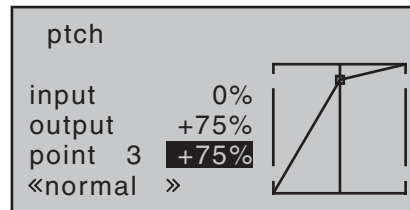

In this example we have moved reference point “3” to +75%.

However, the optional points “2” and “4” can also be activated. In the next example we activate point “2” at -50% ...

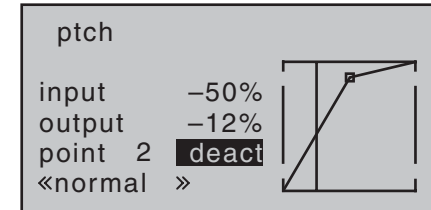

... and point “4” at +50% ...

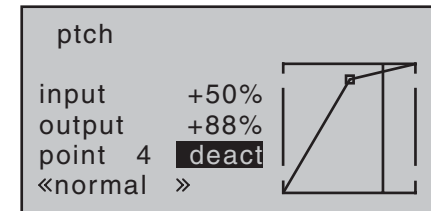

This is accomplished using the stick to move the vertical line to the appropriate area. As soon as the message “inactive” appears in the highlighted value field, you can activate the associated point with the arrow buttons of the right-hand touch-key; it can then be adjusted in the same manner as the other points ...

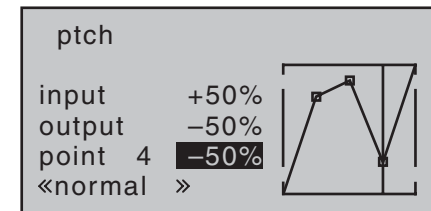

... or reset to “inactive” by simultaneously pressing the ▲ ▼ or ◀ ▶ buttons of the right-hand touch-key (**CLEAR**).

Points “1” and “5”, however, CANNOT be disabled.

Note:

The following illustration, and all the other pictures on this page, show a control curve which we prepared for illustration purposes only. Please note that the curve characteristics by no means represent real collective pitch curves!

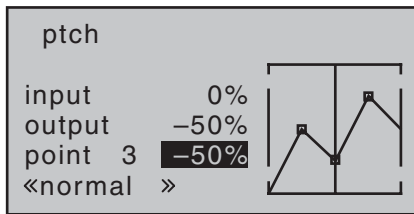

Typical collective pitch curves for different flight phases:

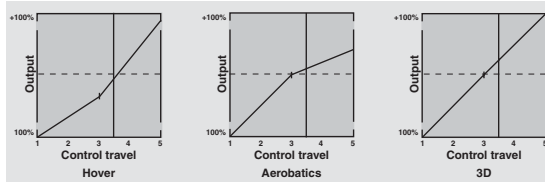

ch1 → thro (throttle curve)

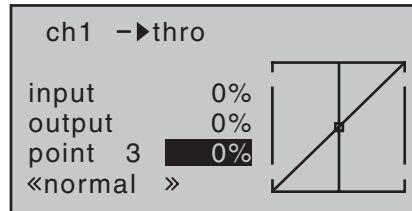

Helicopter with glow engine or electric motor and STANDARD SPEED CONTROLLER

This setting *only* affects the control curve of the throttle servo or speed controller.

The method of setting up a throttle curve for a model helicopter fitted with a speed governor or regulator is discussed later.

The throttle curve can be defined using up to five points, in a similar way to the collective pitch curve (see previous page).

- In all cases the control curve must be set up in such a way that the throttle is fully open, or the speed controller of an electric helicopter is at full power, at the end-point of the throttle / collective pitch stick, (exception: auto-rotation - see page 104).
- The hover point is normally located at the centre of the stick travel, and the throttle setting should be adjusted relative to the collective pitch curve in such a way that the correct system rotational speed is obtained at this point.
- At the minimum position of the throttle / collective pitch stick the throttle curve should initially be set up so that the (glow) motor runs at a distinctly higher speed compared to the idle setting, with the clutch reliably engaged.

In all flight phases the motor (glow or electric) is started and stopped using the throttle limiter (see below).

If you are used to a different radio control system which uses two separate flight phases for this - “with idle-up” and “without idle-up”; therefore incurring the “loss” of one complete flight phase - please note that the throttle limiter renders this complication superfluous, as the increased system rotational speed below the hover point in the **mx-16** HoTT program is more flexible, and can be fine-tuned more accurately, than the “idle-up” system used with earlier **mc** radio control systems.

Ensure that the throttle limiter is closed before you start the glow motor, i.e. the throttle can only be adjusted within its idle range using the idle trim. Be sure to read the safety notes on page 102 which refer to this. If the idle is set too high when you switch the transmitter on, you will see and hear a clear warning!



The following three diagrams show typical 3-point throttle curves for different flight phases, such as hover, aerobatics and 3-D flying.

Typical throttle curves for different flight phases:

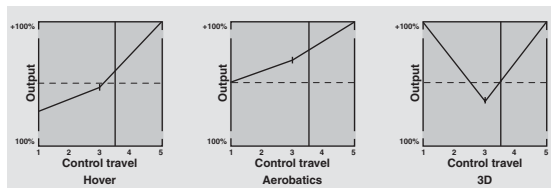

Notes on using the “Throttle limit” function:

- We strongly recommend that you make use of the throttle limit function (“**Transmitter control settings**” menu, page 79). When you use this function the throttle servo is completely disconnected from the throttle / collective pitch stick when the proportional throttle limit control is at its left-hand end-point; the motor runs at idle and only responds to the Ch 1 trim. This feature enables you to start the motor from within any flight phase.

Once the motor is running, turn the throttle limiter slowly to the opposite end-point, so that full control of the throttle servo is returned to the throttle / collective pitch stick. It is important that the throttle limiter should not restrict the throttle servo at its upper end-point; you can avoid this by setting the control travel to +125% in the “Lim” line of the “**Transmitter control settings**” menu.

- Since electric motors by their nature require no idle setting, the only important point when setting up an electric-powered model helicopter is that the adjustment range of the throttle limiter should be set significantly higher and lower than the adjustment range of the speed controller, which is usually from -100% to +100%. It may therefore be necessary to set the “Travel” value of the throttle limiter to an appropriate point

in the “Lim” line of the “**Transmitter control settings**” menu. However, the throttle curve itself has to be fine-tuned with the helicopter in flight, just like a glow-powered machine.

- Releasing the full throttle range, and imposing the throttle limiter again, trips the switching threshold of the control switch “C3” (i.e. in either direction); this switch can be used for automatically starting and stopping the stopwatch to record the flight time, or some similar purpose; see page 39.

When you select auto-rotation, the mixer automatically switches the value to a variable pre-set value; see the section starting on page 104.

Helicopter with speed GOVERNOR (REGULATOR)

In contrast to speed controllers, which simply adjust power output in the same way as a carburettor, speed governors maintain a constant rotational speed in the system which they regulate; they accomplish this by adjusting the power output as required. In the case of a glow-powered helicopter the governor automatically controls the throttle servo; in an electric-powered machine the governor does the same with the speed controller. For this reason speed governors do not require a classic throttle curve; they just need a pre-set rotational speed. Once this is set, the system rotational speed does not alter unless the system calls for more power from the motor than is available.

In most cases a speed governor is connected to receiver output 8; see the receiver socket sequence on page 47. If this socket is already in use, then the throttle limiter function is not used, since this only affects output 6 - which is now not occupied - via the “Ch 1 → throttle” mixer.

However, if you wish to be able to exploit the convenience and safety features of the throttle limiter, the speed governor should be connected to receiver output 6 - in

contrast to the usual socket sequence - and the throttle curve adjusted so that it can simply assume the role of the “usual” transmitter control.

In this case the “throttle curve” only determines the nominal rotational speed of the speed controller, and this nominal value is required to remain constant over the full range of collective pitch; for this reason a horizontal line should be set in the “Ch 1 → throttle” mixer, i.e. every (collective pitch) input value results in the same (“throttle”) output value. The “height” of the line in the graph determines the nominal system rotational speed.

Initially, then, reference point “3” should be erased, and reference points “1” (input = -100%) and “5” (input = +100%) set to the same value; for example:

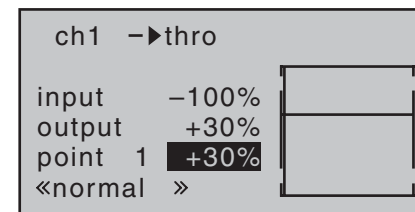

The value to be set varies according to the speed governor you are using, and also to the desired nominal rotational speed; you may wish to vary it, of course, in the various flight phases.

When you select auto-rotation, the mixer automatically switches the value to a variable pre-set value; see the section starting on page 104.

Ch1 → tail rotor (static torque compensation)

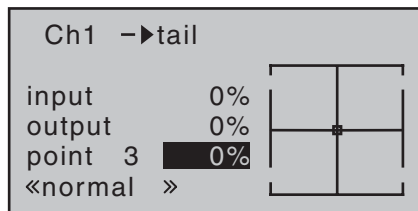

The default setting is a torque compensation curve with a uniform linear mixer input of 0%, as is required for a gyro sensor operating in “heading lock mode”; see illustration above.

Important Note:

It is absolutely essential to read and observe the set-up instructions supplied with your gyro before entering any settings at this point, as a mistake here could render your helicopter uncontrollable.

If you use your gyro sensor in “normal” operating mode, or if the gyro only offers “normal mode”, then you should set up the mixer as follows:

The tail rotor control curve can be defined using up to five points, in a similar way to the collective pitch curve (see previous page). You can therefore modify the mixer at any time when required, and enter symmetrical or asymmetrical mixer inputs both above and below the hover point. However, please ensure at the outset that you have entered the correct direction of main rotor rotation in the “Basic settings” menu.

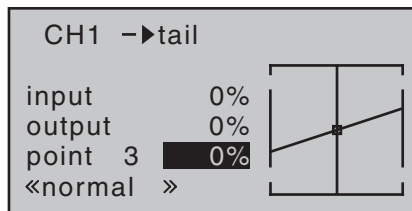

Starting from -30% at Point 1 and +30% at Point 5, this mixer should be set up in such a way that the helicopter does not rotate around the vertical (yaw) axis (i.e. does not deviate from the hover heading) during a long vertical climb or descent, due to the change in torque of the main rotor. At the hover the yaw trim should be set using the (digital) tail rotor trim lever only.

For a reliable torque compensation setting it is essential that the collective pitch and throttle curves have been set up correctly, i.e. that main rotor speed remains constant over the full range of collective pitch.

When you select auto-rotation, this mixer is automatically switched off.

Gyro (adjusting gyro gain)

Most modern gyro systems feature proportional, infinitely variable adjustment of gyro gain as well as a means of selecting either of two different methods of working from the transmitter.

If the gyro you wish to use features at least one of these options, then it offers you the possibility of pre-setting both “normal” gyro effect and - if available - “heading lock mode”, and also of flying normal, slow circuits with maximum gyro stabilisation, but reducing the gyro effect for high-speed circuits and aerobatics. This is generally similar to the transmitter control centre adjustment or offset adjustment provided by other radio control sys-

tems.

We recommend that you set up switchable flight phases for this, and set different gain settings for each phase in the “Gyro” line; values between -125% and +125% are possible.

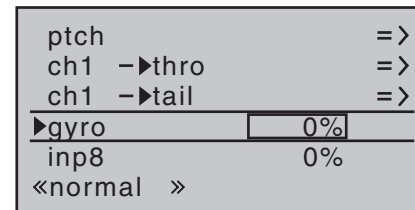

Based on the offset values determined for each flight phase, gyro gain can be varied proportionally by means of a transmitter control assigned in the “Gyro” line of the “Transmitter control settings” menu (see page 78). This could be CTRL 8, which would provide infinitely variable gyro gain control:

- At the centre position of this transmitter control the gyro effect always corresponds to the settings selected here.
- If you turn the rotary proportional control CTRL 8, which we are using in our example, in the direction of full travel (away from centre), the gyro gain increases accordingly ...
- ... and diminishes again if you turn it in the direction of the opposite end-point.

Important Note:

It is absolutely essential to read and observe the set-up instructions supplied with your gyro before entering any settings at this point, as a mistake here could render your helicopter uncontrollable.

Adjusting the gyro sensor

If you wish to set up a gyro to achieve maximum possible stabilisation of the helicopter around the vertical axis, please note the following points:

- The mechanical control system should be as free-moving and accurate (slop-free) as possible.
- There should be no “spring” or “give” in the tail rotor linkage.
- You must use a powerful and - above all - fast servo for the tail rotor.

When the gyro sensor detects a deviation in yaw, the faster it adjusts the thrust of the tail rotor, the further the gyro gain adjuster can be advanced without the tail of the model starting to oscillate, and the better the machine’s stability around the vertical axis. If the corrective system is not fast enough, there is a danger that the model’s tail will start to oscillate even at low gyro gain settings, and you then have to reduce gyro gain further using the rotary proportional control CTRL 8, as used in our example, to adjust the pre-set “Gyro” value to eliminate the oscillation.

If the model is flying forward at high speed, or hovering in a powerful headwind, the net result of the stabilising effect of the vertical fin combined with the gyro’s stabilising effect may be an over-reaction which manifests itself as tail oscillation. In order to obtain optimum stabilisation from a gyro in all flight situations, you should make use of the facility to adjust gyro gain from the transmitter.

inp8

(Input 8)

ptch	=>
Ch1 ->thro	=>
Ch1 ->tail	=>
gyro	0%
▶inp8	<input type="text" value="0%"/>
<<normal >>	

The adjustment facilities in this line of the menu are only relevant if your model helicopter is fitted with a speed governor (regulator) which maintains a constant system rotational speed, and you wish to control it using the “classic” method. The settings should then be entered in accordance with the instructions supplied with the governor you intend to use.

However, it is more convenient - and also safer - to adopt the method described on the preceding double-page, using the “Ch1 → thro” mixer.

Swashplate limiter

Ch1 ->thro	=>
Ch1 ->tail	=>
gyro	0%
inp8	0%
▶swash lim.	<input type="text" value="off"/>
<<normal >>	

This function acts like a circular mechanical gate acting upon the swashplate control stick, restricting its range of travel - which is usually rectangular - to a circular pattern. This is designed to solve the following problem: if the helicopter is set up in such a way that the roll and pitch-axis travels extend to the maximum possible in mechanical terms, e.g. for 3-D helicopter flying, then at

simultaneous full travel of roll and pitch-axis the actual movement of the swashplate is higher (theoretically 141%). In this situation the mechanical swashplate system may strike its end-stops, and in the extreme case the ball-links may even be forced off the linkage balls.

In the **mx-16** HoTT transmitter a software function has the effect of limiting the overall swashplate travel, i.e. the tilt angle of the swashplate between 100% (the travel is limited to the value which can be reached by one function - roll or pitch-axis - alone) and 149% (no limiting in force) is switched “off” (the function is completely disabled). Swashplate limiting can also be adjusted to suit individual models and flight phases.

This software solution is far more flexible than a physical limiter disc attached to the stick unit, and such a disc can only be used in any case if the roll and pitch-axis functions are controlled by one of the two primary sticks.

The sketch alongside shows the effect of the limiter at a setting of 100%: the dotted area of travel is cut off, and appears as a dead zone. If this function is used, you should leave “Dual Rate” at 100%, and you should not set Dual Rate values greater than 100%, otherwise travel will be limited on the roll or pitch-axis individually if the swashplate limiter is set to 100%.

Adjustment range: 100 ... 149% and “off”.

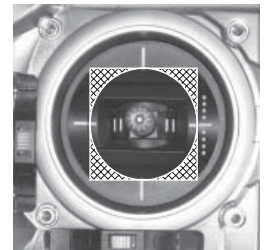

Adjusting the throttle and collective pitch curves

A practical procedure

Although the throttle and collective pitch control systems are based on separate servos, they are always operated in parallel by the throttle / collective pitch stick (except when auto-rotation is invoked). The Helicopter program automatically couples the functions in the required way. In the **mx-16** HoTT program the trim lever of control function 1 only affects the throttle servo, i.e. it acts as idle trim (see “Digital trims” on page 40).

The process of adjusting “throttle” and collective pitch correctly, i.e. setting the motor’s power curve to match the collective pitch setting of the main rotor blades, is the most important aspect of setting up any model helicopter. The program of the **mx-16** HoTT provides independent adjustment facilities for the throttle, collective pitch and torque compensation curves.

These curves can be defined using a maximum of five reference points. To define the control curves all you have to do is set individual values for these five points in order to determine each control curve.

However, before you set up the throttle / collective pitch function it is important to adjust the mechanical linkages to all the servos accurately, in accordance with the set-up notes provided by the helicopter manufacturer.

Note:

The hover point should always be set to the centre position of the throttle / collective pitch stick.

Idle setting and throttle curve

Note:

Since electric power systems by their nature require no idle setting, it is not necessary to adjust the idle value. However, the matching of the throttle and collective pitch curve(s) must still be carried out as described here, in a

similar way to a glow-powered helicopter.

The idle setting is adjusted solely using the trim lever of the Ch 1 function, with the throttle limiter closed, as described in detail on pages 79 to 80.

Reference point 1 of the throttle curve defines the throttle setting when the helicopter is in a descent, but without affecting the hover setting.

This is a case where you can exploit flight phase programming to use different throttle curves. An increased system rotational speed below the hover point proves to be useful in certain circumstances; for example, for fast, steep landing approaches with greatly reduced collective pitch, and for aerobatics.

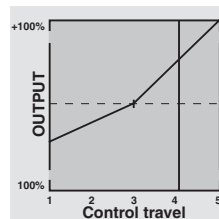

The diagram shows a curve with a slightly altered throttle setting below the hover point at the centre of stick travel.

Different throttle curves are programmed for each flight phase, so that you can use the optimum set-up both for hovering and aerobatics:

- Low system rotational speed with smooth, gentle control response and low noise at the hover.
- Higher speed for aerobatics with motor power settings close to maximum. In this case the throttle curve also has to be adjusted in the hover range.

The basic set-up procedure

Although the **mx-16** HoTT transmitter provides a broad range of adjustment for the collective pitch and throttle curves, it is essential that you first adjust all

the mechanical linkages in the model according to the information supplied by the helicopter manufacturer, i.e. all the system linkages should already be approximately correct in mechanical terms. If you are not sure of how to do this, any experienced helicopter pilot will be glad to help you with the basic set-up.

The throttle linkage must be adjusted in such a way that the throttle is just at the “fully open” position at the full-throttle setting, or the speed controller of an electric helicopter is set to full-power. When the throttle limiter is at the idle position, the Ch 1 trim lever should just be able to close the throttle completely, without the servo striking its mechanical end-stop (quick throttle adjustment using the “digital trim”: see page 40). With an electric helicopter the motor should stop reliably when the throttle limiter is closed.

Take your time, and carry out these adjustments very carefully by adjusting the mechanical linkage and / or changing the linkage point on the servo output arm or the throttle lever. Only when you are confident that all is well should you think about fine-tuning the throttle servo using the transmitter’s electronic facilities.

Caution:

Read all you can about motors and helicopters, so that you are aware of the inherent dangers and the cautionary measures required before you attempt to start the motor for the first time!

With the basic set-up completed, it should be possible to start the motor in accordance with the operating instructions supplied with it, and adjust the idle setting using the trim lever of the throttle / collective pitch stick. The idle position which you set is indicated in the transmitter’s basic screen display by a horizontal bar in the display of the Ch 1 trim lever’s position. Refer to page 40

of this manual for a full explanation of the digital trims. Around the mid-point of the collective pitch stick the model should lift off the ground and hover at approximately the rotational speed you wish to use. If this is not the case, correct the settings as follows:

1. The model does not lift off until the collective pitch stick is above the centre point.

a) Rotational speed too low

Remedy: on the “Ch 1 → throttle” graphic page, increase the value at Point 3.

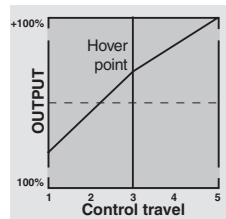

b) Rotational speed too high

Remedy: on the “Collective pitch” graphic page, increase the blade pitch angle for collective pitch by increasing the value at Point 3.

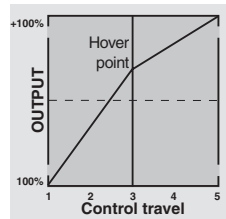

2. The model lifts off below the centre point.

a) Rotational speed too high

Remedy: on the “Ch 1 → throttle” graphic page, reduce the throttle opening by reducing the value at Point 3.

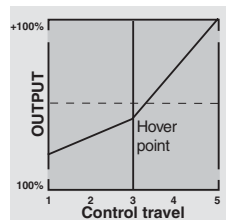

b) Rotational speed too low

Remedy: on the “Collective pitch” graphic page, reduce the blade pitch angle by reducing the value at Point 3.

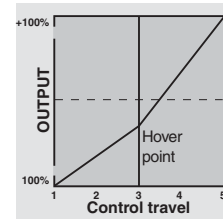

Important:

It is important to persevere with this adjustment procedure until the model hovers at the correct rotational speed at the centre point of the throttle / collective pitch stick. All the other model settings depend upon the correct setting of these parameters!

The standard set-up

The remainder of the standard adjustment procedure is completed on the basis of the fundamental set-up which you have just carried out, i.e. we now assume that the model hovers in normal flight at the centre point of the throttle / collective pitch stick, with the correct rotor speed. This means that your model helicopter is capable of hovering and also flying circuits in all phases whilst maintaining a constant system rotational speed.

The climb setting

The combination of throttle hover setting, collective pitch setting for the hover and the maximum collective pitch setting (Point 5) now provides you with a simple method of achieving constant system rotational speed from the hover right to maximum climb.

Start by placing the model in an extended vertical climb, holding the collective pitch stick at its end-point: motor speed should not alter compared with the hover setting. If motor speed falls off in the climb, when the throttle is

already fully open and no further power increase is possible (this assumes that the motor is correctly adjusted), then you should reduce the maximum blade pitch angle at full deflection of the collective pitch stick, i.e. the value at Point 5. Conversely, if motor speed rises during the vertical climb, you should increase the pitch angle. This is done on the “Collective pitch” graphic page by moving the vertical line to Point 5 using the collective pitch stick, and changing its value accordingly using the arrow buttons ▲ ▼ of the right-hand touch-button.

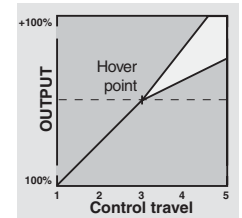

This diagram shows the changes to the collective pitch maximum value only.

Now bring the model back to the hover, which again should coincide with the mid-point of the Ch 1 stick. If you find that the collective pitch stick now has to be moved from the mid-point in the direction of “higher”, then you should correct this deviation by slightly increasing the collective pitch angle at the hover - i.e. Point 3 - until the model again hovers at the stick centre point. Conversely, if the model hovers below the mid-point, correct this by reducing the pitch angle once more. You may find that it is also necessary to correct the throttle opening at the hover point (Point 3) in the “Ch 1 → throttle” menu.

This diagram only shows the change in the hover point, i.e. collective pitch minimum and maximum have been left at -100% and +100% respectively.

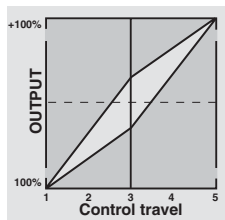

Continue adjusting these settings until you really do achieve constant main rotor speed over the full control range between hover and climb.

The descent adjustment should now be carried out from a safe height by fully reducing collective pitch to place the model in a descent from forward flight; adjust the collective pitch minimum value (Point 1) so that the model descends at an angle of 60 ... 80°. This is done on the "Collective pitch" graphic page by moving the vertical line to Point 1 using the collective pitch stick, and adjusting the value accordingly using the arrow buttons of the right-hand touch-key.

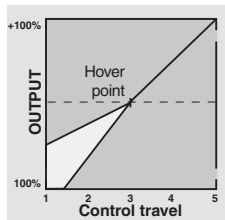

As an example, this diagram shows the changes in the collective pitch minimum value only.

Once the model descends reliably as described, adjust the value for "Throttle minimum" - the value of Point 1 on the graph of the "Ch 1 → throttle" mixer - so that system rotational speed neither increases nor declines. This completes the set-up procedure for throttle and collective pitch.

Important final notes

Before you start the motor, check carefully that the throttle limiter is completely closed, so that the throttle can be controlled by the Ch 1 trim lever alone. If the throttle is too far open when you switch the transmitter on, you will see and hear a warning. If you ignore this and start the motor with the throttle too far advanced, there is a danger that the motor will immediately run up to speed after starting, and the centrifugal clutch will at once engage.

For this reason you should:

always grasp the rotor head firmly when starting the motor.

However, if you accidentally start the motor with the throttle open, the rule is this:

Don't panic!

Hang on to the rotor head regardless!

Don't let go!

Immediately reduce the throttle limiter, even though there may be a risk of damaging the helicopter's drive train, because:

it is vital that YOU ensure that the helicopter cannot possibly move off by itself in an uncontrolled manner.

The cost of repairing a clutch, a gearbox or even the motor itself is negligible compared with the damage which a model helicopter can cause if its spinning rotor blades are allowed to wreak havoc.

Make sure that nobody else is standing in the primary hazard zone around the helicopter.

You must never switch abruptly from idle to the flight setting by suddenly increasing system rotational speed, as this would cause the rotor to accelerate quickly, resulting

in premature wear of the clutch and gear train. The main rotor blades are generally free to swivel, and they may be unable to keep pace with such swift acceleration, in which case they might respond by swinging far out of their normal position, perhaps resulting in a boom strike. Once the motor is running, you should **slowly** increase system rotational speed using the throttle limiter.

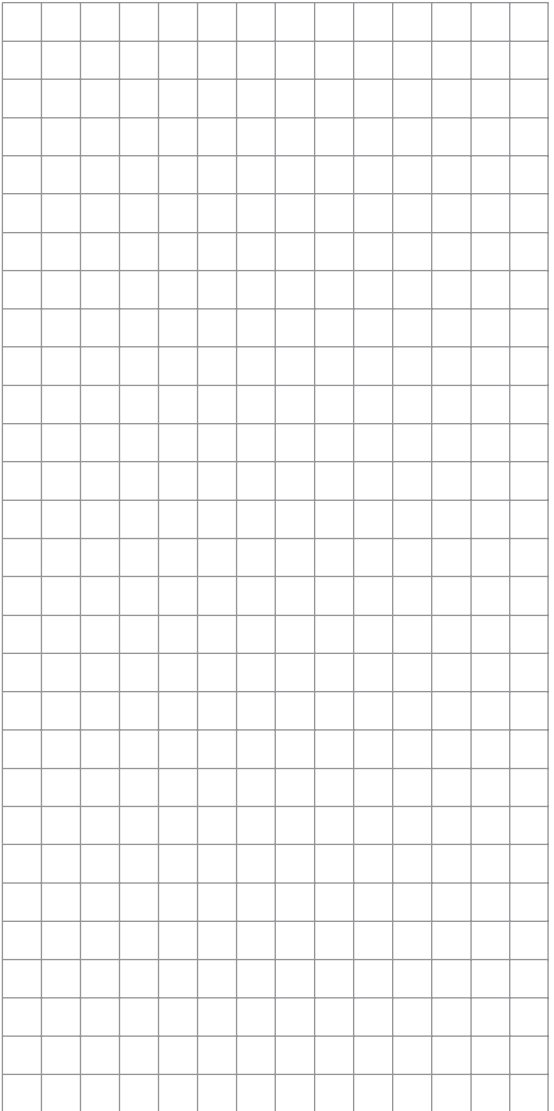
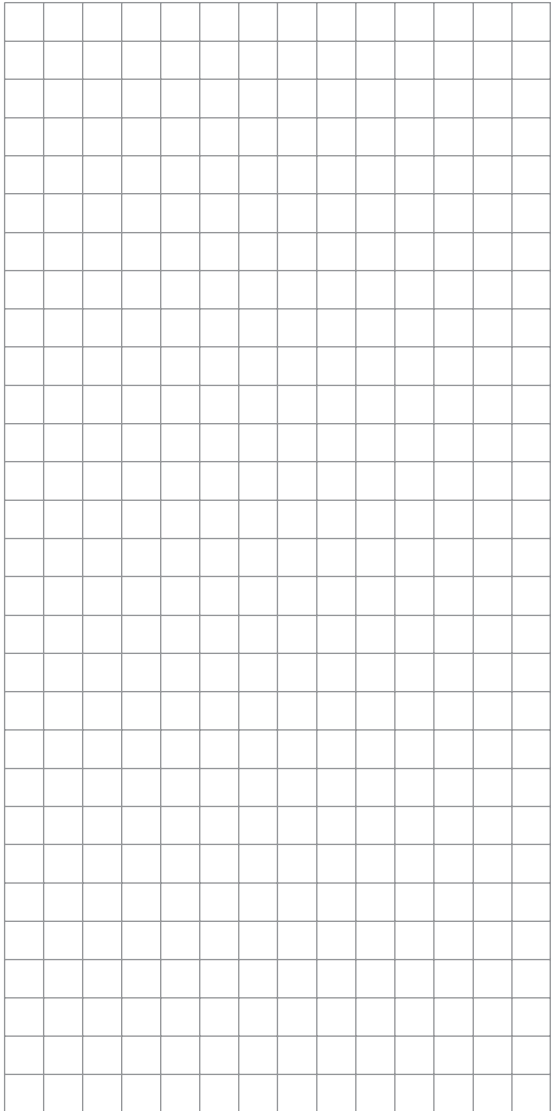
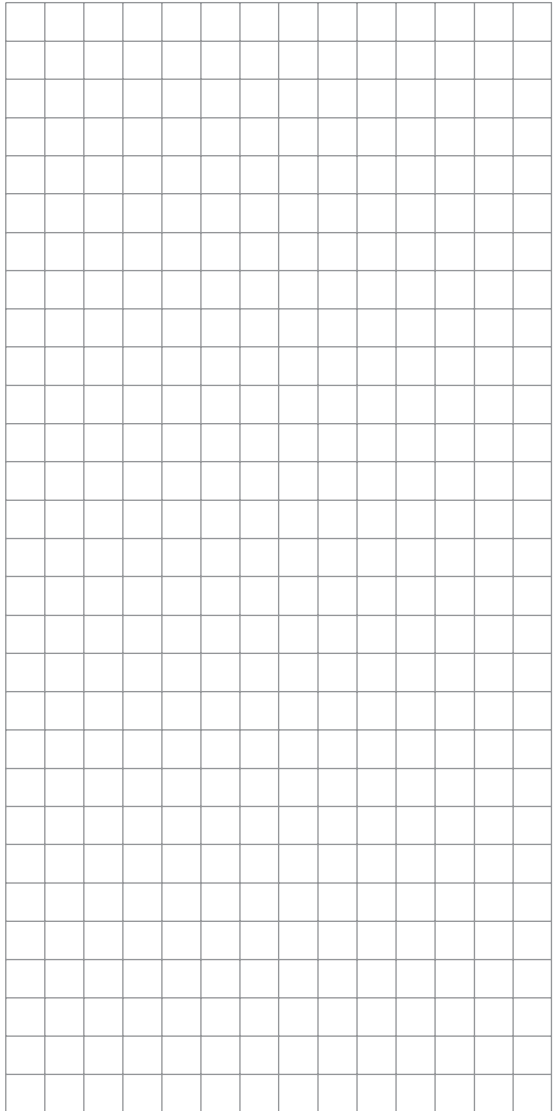



Helicopter mixers

Auto-rotation settings

Auto-rotation allows full-size and model helicopters to land safely in a crisis, i.e. if the power plant should fail. It can also be used if the tail rotor should fail, in which case cutting the motor and carrying out an auto-rotation landing is the only possible way of avoiding a high-speed uncontrollable rotation around the vertical axis, invariably terminating in a catastrophic crash. And that is the reason why switching INTO auto-rotation occurs with zero delay.

When you switch to the auto-rotation phase the helicopter mixers change as shown in this screen shot:

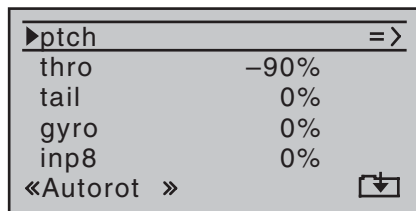

During an auto-rotation descent the main rotor is not driven by the motor; it is kept spinning only by the airflow through the rotor disc caused by the speed of the descent. The rotational energy stored in the still spinning rotor can be consumed to allow the machine to flare out, but this can only be done once. For this reason “autos” are only likely to be successful if the pilot has plenty of experience in handling model helicopters, and has also set up the appropriate functions with great care.

Once you have sufficient experience you should practise auto-rotation landings at regular intervals, not only so that you can demonstrate your all-round flying skill by flying the manoeuvre in competitions, but also so that you are in a position to land the helicopter undamaged from a great height if the motor should fail. For this purpose the program provides a range of adjustment fa-

cilities which are designed to help you fly your helicopter in its unpowered state. Please note that the auto-rotation setting takes the form of a complete fourth flight phase, for which all the adjustment facilities are available which can be varied separately for all flight phases, especially trims, collective pitch curve settings etc.

ptch (Collective pitch curve (Ch1 → pitch))

In powered flight the maximum blade pitch angle is limited by the motor power which is available; however, in auto-rotation the angle is only limited by the point at which the airflow over the main rotor blades breaks away. Nevertheless, to provide sufficient upthrust even when rotational speed is falling off, it is necessary to set a greater maximum collective pitch value. Touch the central **SET** button of the right-hand touch-key to select the graph page of “Collective pitch”, and then move the vertical line to Point 5 using the transmitter stick. Start by setting a value which is about 10 to 20% higher than your normal collective pitch maximum. Do NOT set a *much* higher value compared with normal flight initially, because collective pitch control will then differ too greatly from the machine’s usual response after you have thrown the switch. The danger is that you will over-control the helicopter, and it may balloon up again during the flare following the auto-rotation descent. If this happens, the rotational speed of the main rotor will quickly decline to the point where it collapses, and the helicopter ends up crashing to the ground from a considerable height. Later, after a few trial autos, you may wish to adjust the value again.

Under certain circumstances the collective pitch minimum setting *may* also differ from the normal flight setting; this depends on your piloting style for normal flying. In any case you must set a sufficiently generous collec-

tive pitch minimum value at Point 1 to ensure that your model can be brought from forward flight at moderate speed into a descent of around 60 ... 70° when collective pitch is reduced to minimum. Most helicopter pilots already use such a setting for normal flying, and if this applies to you, you can simply adopt the same value. If you normally allow your model to “fall” at a shallower angle, increase the value for “Point 1”, and vice versa.

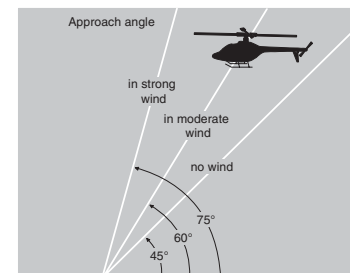

Approach angle under varying wind conditions.

For auto-rotation the collective pitch stick itself may not be positioned right at the bottom of its travel; typically it will be between the hover position and the bottom end-point, giving the pilot scope for correction if necessary, i.e. the chance to adjust the model’s pitch inclination using the pitch-axis control.

You can shorten the approach by pulling back slightly on the pitch-axis stick and gently reducing collective pitch, or alternatively extend the approach by pushing forward on the pitch-axis stick and gently increasing collective pitch.

Throttle (throttle curve)

In a competition the pilot is expected to cut the motor completely, but for practice purposes this is certainly inconvenient, as after every practice “auto” landing you would have to start the motor again.

For practice, then, you should set the value in this line so that the motor runs at a reliable idle during auto-rotation, but without the clutch engaging, so that you can open the throttle immediately to recover from an emergency; for an electric helicopter the motor should be reliably “off”.

Tail rotor (static torque compensation)

For normal flying the tail rotor is set up in such a way that it compensates for motor torque when the helicopter is hovering. This means that it already generates a certain amount of thrust even in its neutral position. The level of thrust is then varied by the tail rotor control system, and also by the various mixers which provide all manner of torque compensation, while the tail rotor trim is also used to compensate for varying weather conditions, fluctuations in system rotational speed and other influences.

However, in an auto-rotation descent the main rotor spins according to the windmill principle, i.e. it is not driven by the motor, and therefore there is no torque effect for which compensation is required, i.e. which the tail rotor would have to correct. For this reason all the appropriate mixers are automatically switched off in auto-rotation mode.

However, the basic tail rotor setting therefore has to be different for auto-rotation, as the compensatory thrust described above is no longer required:

Stop the motor and place the helicopter horizontal on the ground. With the transmitter and receiving system switched on, select the “**Auto-rotation**” flight phase. Fold both tail rotor blades down and change the blade pitch angle to zero degrees in the “Tail rotor” line. Viewed from the rear, the tail rotor blades should now lie parallel to each other.

Depending on the friction and running resistance of the gearbox, you may find that the fuselage still yaws slightly in an auto-rotation descent. If necessary, the relatively slight torque which causes this effect must then be corrected by adjusting the tail rotor blade pitch angle. This value will always be a small figure between zero degrees and a pitch angle opposed to the direction of tail rotor pitch required for normal flight.

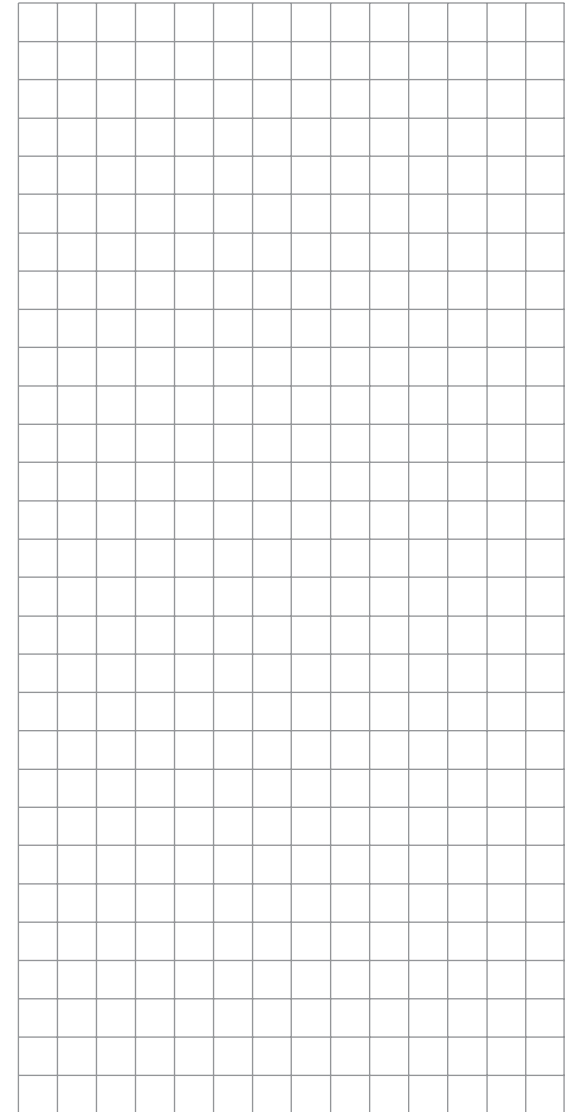



General notes regarding freely programmable mixers

The two menus “**Fixed-wing mixers**” and “**Helicopter mixers**”, as described on the preceding pages, contain a wide range of ready-programmed coupling functions. The basic meaning of mixers has already been explained on page 88, together with the principle on which they work. In the following section you will find information relating to “free mixers”:

In addition to the pre-programmed mixers mentioned above, the **mx-16** HoTT offers three freely programmable linear mixers which can be used in every model memory; their inputs and outputs can be selected to suit your exact requirements.

Any *control function* (1 to 8), or what is known as a “switch channel” (see below), can be assigned as the *input signal* of a “free mixer”. The signal present at the control channel, and passed to the mixer input, is determined by the transmitter control *and* any control characteristics as defined, for example, in the “**D/R Expo**” and “**Transmitter control settings**” menus.

The mixer output acts upon a *freely selectable control channel* (1 to max. 8 - depending on receiver type). Before the signal is passed to the associated servo, the only influences which can act upon it are those defined in the “**Servo settings**” menu, i.e. the servo reverse, centre and travel functions.

One *control function* can be set up to affect several mixer inputs simultaneously, if, for example, you wish to arrange several mixers to operate in parallel.

Conversely it is possible for several mixer outputs to affect one and the same *control channel*.

The following description of the free mixers includes examples of such arrangements.

In software terms the default setting for any “free mixer” is that it is constantly switched on, but it is also possible

to assign an optional ON / OFF switch to it. However, since there are so many functions to which switches can potentially be assigned, you should take care not to assign dual functions to particular switches accidentally.

The two important mixer parameters are as follows:

- ... the **mixer ratio**, which defines the extent to which the input signal acts on the output of the control channel which is programmed as the mixer output.
- ... the **neutral point**, which is also termed the “offset”. The offset is that point on the travel of a transmitter control (stick, rotary proportional knob CTRL 6 ... 8 and SW 1 ... 9) at which the mixer has no influence on the control channel connected to its output. Normally this is the centre point of the transmitter control, but the offset can be placed at any point on the control’s travel.

Switch channel “S” as mixer input

In some cases a constant control signal is all that is required as the mixer output; a typical application would be for slight up-elevator trim when an aero-tow coupling is closed - completely independently of the normal elevator trim.

If you then assign a switch, you can switch to and fro between the two mixer end-points, and adjust the supplementary elevator trim deflection by altering the mixer ratio.

To identify this special arrangement, this mixer input control function is designated “S” for “switch channel” in the software. If you do not want the “target channel” to be affected by the “normal” transmitter control, the control can be de-coupled from the function input of the associated control channel by entering “free” in the “**Transmitter control settings**” menu; see pages 74

and 76. The following menu description again includes an example which makes this function clear.

Now use the arrow buttons of the left or right-hand touch-key to leaf through to the “**Free mixers**” menu point of the multi-function menu:

mod. mem.	base sett.
servo set.	contr set.
D/R expo	phase trim
wing mixer	free mixer
servo disp	basic sett
fail-safe	telemetry

mod. mem.	base sett.
servo set.	contr set.
D/R expo	heli mixer
free mixer	swashp.mix
servo disp	basic sett
fail-safe	telemetry

Touch the central **SET** button of the right-hand touch-key to open this menu point.



Free mixers

Linear mixers

Regardless of the selected model type, three linear mixers are available for each of the twenty model memories, with the additional possibility of setting up non-linear characteristic curves.

In this first section we will concentrate on the programming procedure for the first screen page. We will then move on to the method of programming mixer ratios, as found on the second screen page of this menu.

The basic programming procedure

1. Use the arrow buttons ▲ ▼ of the left or right-hand touch-key to select the desired mixer.
2. Briefly press the central **SET** button of the right-hand touch-key: the input field in the column marked "fro(m)" at the bottom edge of the screen is now highlighted (black background).
3. Use the arrow buttons of the right-hand touch-key to define the mixer input "fro(m)".
4. Touch the central **SET** button of the right-hand touch-key; switch to the "to" column using the ► button of the left or right-hand touch-key, then touch the central **SET** button of the right-hand touch-key once more: the input field "to" is now highlighted.
5. Use the arrow buttons of the right-hand touch-key to define the mixer input "to".
6. Touch the central **SET** button of the right-hand touch-key, and (optionally) use the ◀ button of the left or right-hand touch-key to move to the column marked "Type" at the bottom edge of the screen; you can now include the Ch1 ... Ch 4 trim lever for the mixer input signal ("Tr" for trim) ...
7. ... and / or use the ► arrow button of the left or right-hand touch-key to move to the column marked with the switch symbol  at the bottom edge of the

screen, touch the central **SET** button of the right-hand touch-key again, and assign a switch if desired, as described on page 39.

8. Use the arrow button ► of the left or right-hand touch-key to move to the => column, then touch the central **SET** button of the right-hand touch-key.
9. Define the mixer ratios on the second screen page.
10. Press the central **ESC** button of the left-hand touch-key to switch back to the first page.

"fro(m)"

After briefly pressing the central **SET** button of the right-hand touch-key, select the highlighted field of the selected mixer line using the arrow buttons of the same touch-key, and select one of the *control functions* 1 ... 8 or S.

In the interests of clarity, the control functions 1 ... 4 are abbreviated as follows when dealing with the fixed-wing mixers:

c1	Throttle / airbrake stick
ar	Aileron stick
el	Elevator stick
rd	Rudder stick

... and in the Heli program:

1	Throttle / collective pitch stick
2	Roll stick
3	Pitch-axis stick
4	Tail rotor stick

Note:

Don't forget to assign transmitter controls to the selected

control functions 5 ... 8 for a fixed-wing model, or 5, 7 and 8 for a model helicopter, in the "Transmitter control settings" menu.

"S" for switch channel

The letter "S" (switch channel) in the "from" column has the effect of passing a *constant* input signal to the mixer input, e.g. in order to apply a little extra up-elevator trim when an aero-tow coupling is closed, as mentioned earlier.

Once you have assigned a control function or the letter "S" in the "from" column, an additional ...

"to"

... appears at the bottom edge of the screen.

In the input field of this column you can define the *control channel* as the mixer destination, i.e. the mixer output. At the same time additional fields appear at the bottom line of the screen:

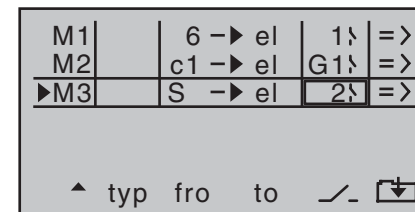

In this example three mixers have already been defined. The second mixer ("Brake → el") is already familiar to us from the "Fixed-wing mixers" menu. As a general rule you should always start by using these pre-programmed mixers if possible.

However, if you need asymmetrical mixer ratios on both sides of centre, or have to offset the mixer neutral point, then you should set or leave the pre-set mixers at "0", and program one of the free mixers instead.

Erasing mixers

If you need to erase a mixer that you have already defined, use the arrow buttons ▲▼ of the left or right-hand touch-key to select its line, then use the arrow buttons ◀▶ to move to the “from” column before touching the central **SET** button of the right-hand touch-key. The field in the “from” column of the mixer to be erased is now highlighted: simultaneously touch the two arrow buttons ▲▼ or ◀▶ of the right-hand touch-key (**CLEAR**).

Mixer switches

In our example above, a physical switch “2” and the control switch “C1” have been assigned to the two linear mixers 1 and 2, and switch “3” to mixer 3.

The switch symbol to the right of the switch number shows the current status of that switch.

Any mixer to which no switch has been assigned in the column marked by the switch symbol  at the bottom of the screen is permanently switched on.

“Type” (including the trim)

If you wish, and if you are using one of the primary control functions 1 ... 4, you can set the trim value of the digital trim lever for the associated stick to affect the mixer input. This is accomplished by touching the central **SET** button of the right-hand touch-key, then using its arrow buttons to select “Tr” in the highlighted field.

Note:

The effect of the Ch 1 trim lever on the mixer output varies according to the function which has been assigned to it in the “Basic settings” menu (pages 56 and 64) in the “Motor at Ch 1” column for fixed-wing models.

Additional special features of free mixers

If you set up a mixer whose input is the same as its output, e.g. “c1 → c1”, exotic results can be obtained in conjunction with the option of switching a free mixer on and off. You will find one typical example of this on pages 150 ... 152.

Before we come to setting mixer ratios, we have to consider what happens if a mixer input is allowed to act on the pre-set coupling of aileron servos, flap servos or collective pitch servos:

• Fixed-wing models:

Depending on the number of wing servos set in the “Aileron / Flap” line of the “Basic settings” menu, receiver outputs 2 and 5 are reserved for the aileron servos, and outputs 6 and 7 for the two flap servos, as special mixers are assigned to these functions.

If mixer outputs are programmed to this type of coupled function, you have to consider their effect on the associated pair of wing flaps, according to the “receiving” control channel:

Mixer	Wirkung
NN * → 2	Servo pair 2 + 5 responds with aileron function
NN * → 5	Servo pair 2 + 5 responds with flap function
NN * → 6	Servo pair 6 + 7 responds with flap function
NN * → 7	Servo pair 6 + 7 responds with aileron function

* NN = Nomen Nominandum (name to be stated)

• Model helicopters:

Depending on the type of helicopter, up to four servos may be employed for collective pitch control; these will be connected to receiver outputs 1, 2, 3 and 5. The transmitter software links them together to provide the functions collective pitch, roll and pitch-axis.

It is **not** advisable to mix one of the transmitter controls into these occupied channels using the free mixers available outside the “Heli mixers” menu, as you may inadvertently generate some extremely complex and unwanted interactions. “Collective pitch trim via a separate transmitter control” counts as one of the few exceptions to this rule; see example 2 at page 111.

Important note:

When dealing with the interaction of multiple mixers on one control channel, it is essential to remember that the mixed travels of the individual mixers are cumulative when multiple stick commands are made simultaneously, and this brings a danger that the servo concerned may strike its mechanical end-stops. If you encounter this problem, simply reduce the servo travel in the “Servo settings” menu, and / or reduce the mixer values. However, if you do not wish to reduce the travels in this way, because this method would unnecessarily reduce the control travels you normally use, then you may prefer an alternative method of preventing the servos striking their end-stops: set a suitable travel limit in the “TRAVEL +/-” lines of the “RX SERVO” display page of the “Telemetry” menu.

Mixer ratios and mixer neutral point

Now that we have explained the wide-ranging nature of the mixer functions, we can move on to the method of programming linear and non-linear mixer curves.

For each of the three available mixers the mixer curves are programmed on a second page of the screen display. Use the arrow buttons ▲▼ of the left or right-hand touch-key to select the desired mixer line, use its arrow buttons to move to the right-hand column (=>), then touch the central **SET** button of the right-hand touch-key to switch to the graphic page.

Setting up linear mixer values

In the next section we will describe a typical practical application, by defining a linear mixer curve intended to solve the following problem:

We have a powered model with two flap servos connected to receiver outputs 6 and 7, which were programmed as "... 2FL" in the "Ail / Flap" line of the **"Basic settings"** menu. These control surfaces are to be employed as landing flaps, i.e. when the associated transmitter control is operated, they deflect down only. However, this flap movement requires an elevator trim correction to counteract the resultant pitch trim change.

In the **"Transmitter control settings"** menu, assign the rotary proportional control CTRL 7 to input 6. The control assigned to input 6 now operates the two servos connected to receiver outputs 6 and 7 in the standard way, operating as simple wing flaps.

"Transmitter control settings" menu

15	free	+100%	+100%
▶ 16	ctrl 7	+100%	+100%
17	free	+100%	+100%
18	free	+100%	+100%

▼ ▲ - trv +

Note:

If you assign a transmitter control to input 7 and select two flap servos, input 7 is automatically de-coupled to avoid possible flap malfunctions.

Start by rotating the transmitter control to its left-hand end-point, and adjust the landing flap linkages so that they are in the neutral position at this setting. If you now turn the knob to the right, the flaps should deflect down; if they move up, you must reverse the direction of servo rotation.

Now we turn to the first mixer on the screen on page 107; this is the mixer "6 → el", to which switch 2 has been assigned:

▶ M1		6 → el	1 ↘ =>
M2		c1 → el	C1 ↘ =>
M3		S → el	2 ↘ =>

▼ typ fro to ↘ ↙

Touch the central **SET** button of the right-hand touch-key to open the second screen page:

MIX1	6 → el	off
------	--------	-----

If this display appears, you have not activated the mixer by operating the assigned external switch - in this case "2". To correct this, operate the switch:

MIX1	6 → el	
▶ trv	0%	0%
offs	0%	
▼	SYM	ASY

The full-height vertical line in the graph represents the current position of the transmitter control assigned to input 6. (In the above graph this is located at the left-hand edge because CTRL 7 is at its left-hand end-point, as already mentioned.) The full-length horizontal line shows the mixer ratio, which currently has the value of zero over the whole of stick travel; this means that the elevator will not "follow" when the flaps are operated. The first step is to define the offset (mixer neutral point). To do this press the arrow button ▼ of the left or right-hand touch-key and move to the "Offs" line:

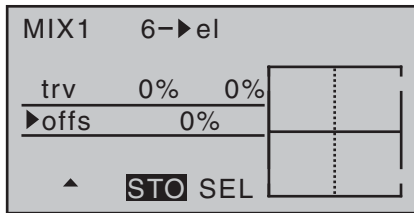

The dotted vertical line indicates the position of the mixer neutral point (“offset”), i.e. that point along the control travel at which the mixer has NO influence on the channel connected to its output. By default this point is set to the centre position.

However, in our example the neutral (retracted) position of the flaps is located at the left-hand end-stop of the rotary proportional control, and in this position the elevator must not be affected. We therefore have to shift the mixer neutral point exactly to that position. If you have not already done so, turn the control - in our example this is CTRL 7 - to the left-hand end-stop and touch the central **SEL** button of the right-hand touch-key. The dotted vertical line now moves to this point - the new mixer neutral point - which always retains the “OUTPUT” value of zero in accordance with the mixer definition.

As it happens, this setting is difficult to show in a screen shot, so we will change the “offset” value to only -75%.

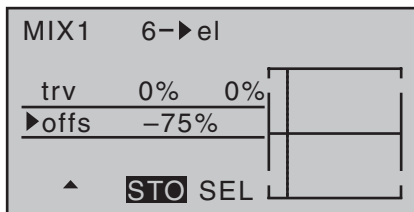

Notes:

- If you wish, you can move the offset value back to centre or otherwise adjust it as follows: select **SEL** using the arrow button **▶** of the left or right-hand touch-key, followed by briefly pressing the central **SET** button of the right-hand touch-key; you can now use the arrow buttons of the left or right-hand touch-key to move the offset value.
- You can also return the mixer neutral point to centre automatically as follows: select **SEL** using the arrow button **▶** of the left or right-hand touch-key, then simultaneously press the two arrow buttons **▲▼** or **◀▶** of the right-hand touch-key (**CLEAR**).

Symmetrical mixer ratios

The next step is to define the mixer values above and below the mixer neutral point, starting from its current position. Use the arrow button **▲** of the left or right-hand touch-key to move to the “Travel” line: if necessary, use the arrow buttons **◀▶** of the left or right-hand touch-key to select the **SYM** field, so that you can set the mixer value symmetrically relative to the offset point you have just programmed. Touch the central **SET** button of the right-hand touch-key, then set the values in the two highlighted fields within the range -150% to +150% using the arrow buttons of the right-hand touch-key. Remember that *the set mixer value always refers to the input signal from the associated transmitter control (control signal)*! Setting a negative mixer value reverses the direction of the mixer.

Simultaneously pressing the two arrow buttons **▲▼** or **◀▶** of the right-hand touch-key (**CLEAR**) erases the mixer ratio in the highlighted field.

The “optimum” value for our purposes will inevitably

need to be established through a flight testing programme.

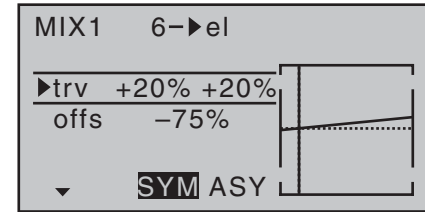

Since we previously set the mixer neutral point to -75% of control travel, the elevator (“el”) will already exhibit a (slight) “down-elevator effect” at the neutral point of the landing flaps, and this, of course, is not wanted. To correct this we shift the mixer neutral point back to -100% of control travel, as described earlier.

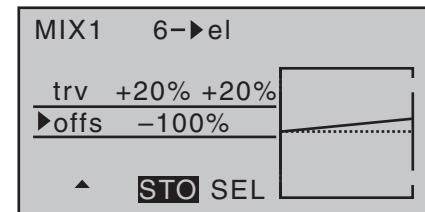

If you were now to reset the offset from -75% to, say, 0% control travel, by selecting the **SEL** field using the arrow buttons **▶** of the left or right-hand touch-key, and then briefly pressing the two arrow buttons **▲▼** or **◀▶** of the right-hand touch-key (**CLEAR**) simultaneously, the screen would look like this:

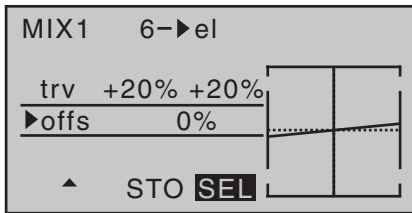

Asymmetrical mixer ratios

For many applications it is necessary to set up different mixer values on either side of the mixer neutral point. Start by resetting the offset of the mixer used in our example ("6 → el") to 0%, as shown in the picture above. Now use the arrow button ► of the left or right-hand touch-key to select the **ASY** field, and then touch the central **SEL** button of the right-hand touch-key. If you now turn the rotary proportional control CTRL 7 - assigned in our example to input 6 - in the appropriate direction, the mixer ratio for each direction of control can be set separately, i.e. to left and right of the selected offset point using the arrow buttons of the right-hand touch-key:

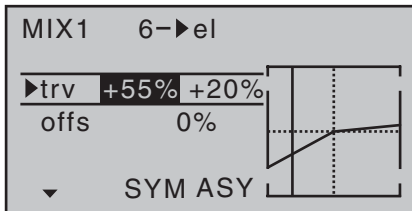

Note:

If you are setting up a switch channel mixer of the "S → NN" type, you must operate the assigned switch to achieve this effect. The vertical line then jumps between

* NN = Nomen Nominandum (name to be stated)

the left and right sides.

Examples:

1. The switch SW3 has already been assigned to control channel 8 in the "Transmitter control settings" menu, in order to open and close the aero-tow release.

15	free	+100%	+100%
16	ctrl 7	+100%	+100%
17	free	+100%	+100%
▶ 18	2	+100%	+100%

▲ - trv +

In the meantime you have carried out a few aero-tow flights, which showed that you always needed to hold in slight up-elevator during the tow. You now wish to set the elevator servo (connected to receiver output 3) to slight "up" trim when the tow release is closed. In the screen display familiar from page 107 we have set up the third linear mixer to accomplish this, using the switch channel "S" as the mixer input. Now move the selected switch to the OFF position, and move to the ...

M1	6 -> el	1 ↗ =>
M2	c1 -> el	C1 ↗ =>
▶ M3	S -> el	2 ↗ =>

▲ typ fro to ↘ ↙

... mixer set-up page.

Use the arrow button ▼ of the left or right-hand touch-key to select the "Offs" line, then touch the cen-

tral **SEL** button of the right-hand touch-key. According to the travel setting selected in the "Transmitter control settings" menu and the switch position, the offset value now jumps to +X% or -X%, e.g.:

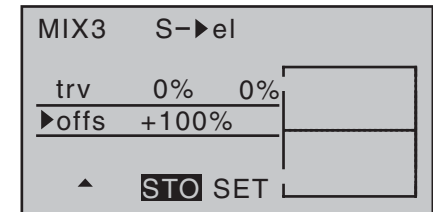

Use the arrow button ▲ of the left or right-hand touch-key to move to the "Travel" line, then touch the central **SEL** button of the right-hand touch-key. After moving the selected switch to the mixer ON position, set the required mixer ratio in the now highlighted value fields using the arrow buttons of the right-hand touch-key.

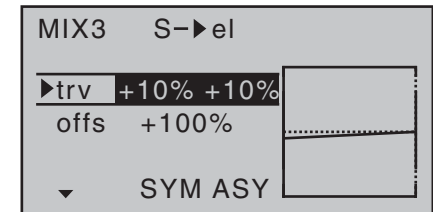

2. The following example applies to model helicopters: In the Helicopter program you may wish to assign one of the rotary proportional controls (CTRL 6 ... 8) to the collective pitch trim function. This is the procedure: in the "Transmitter control settings" menu assign one of these two transmitter controls to input "E8". Now simply define a free mixer "8 → 1" with a symmetrical mixer ratio of, say, 25%. Due to the internal coupling, this transmitter control now acts equally



Swashplate mixers

Collective pitch, roll and pitch-axis mixers

on all the collective pitch servos you are using, without affecting the throttle servo.

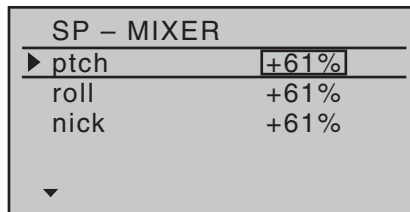
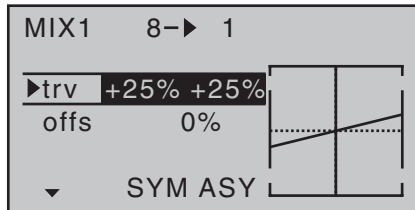

In the “Swashplate” line of the “**Basic settings**” menu you have already defined the number of servos which are installed in your helicopter to provide collective pitch control; see page 67. With this information the transmitter software automatically superimposes the functions for roll, pitch-axis and collective pitch as required, i.e. you do not need to define any additional mixers yourself.

If you have a model helicopter which only has a single collective pitch servo, the “Swashplate mixer” menu point is - of course - superfluous, since the three swashplate servos for collective pitch, pitch-axis and roll are controlled independently of each other, i.e. no mixers are used. In this case the swashplate mixer menu does not appear in the multi-function list. With all other swashplate linkages employing 2 ... 4 collective pitch servos, the mixer ratios and directions are set up by default, as can be seen in the screen shot above. The pre-set value is +61% in each case, but the value can be varied within the range -100% to +100% using the arrow buttons of the right-hand touch-key, after touching the central **SET** button of the same touch-key.

Simultaneously pressing the two arrow buttons ▲ ▼ or ◀ ▶ of the right-hand touch-key (**CLEAR**) resets the mixer input in the highlighted field to the default value of +61%.

If the swashplate control system (collective pitch, roll and pitch-axis) does not follow the transmitter sticks in

the proper manner, then the first step is to change the mixer directions (“+” or “-”), before you attempt to correct the directions of servo rotation.

Note:

Ensure that the servos do not strike their mechanical end-stops if you change the mixer values.



Servo display

Use the arrow buttons of the left or right-hand touch-key to leaf through to the “**Servo display**” menu point of the multi-function menu:

mod.mem.	base sett.
servo set.	contr set.
D/R expo	phase trim
wing mixer	free mixer
servo disp	basic sett
fail-safe	telemetry

Open the menu point by touching the central **SET** button of the right-hand touch-key.

However, this visual display of the current servo positions can be called up not only by selecting this menu, but also directly by simultaneously pressing the buttons ◀ ▶ of the left-hand touch-key from the transmitter’s basic display, and also from almost any menu position. Touching the central **ESC** button of the left-hand touch-key returns you to your starting point again.

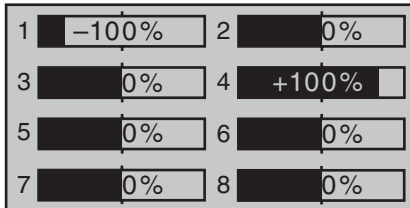

The current position of any servo is displayed in bar-chart form, which takes into account the transmitter control and servo settings, the Dual-Rate / Expo functions, the interaction of all active mixers etc., within the range -150% to +150% of normal travel. 0% corresponds exactly to the servo centre position. The servo display provides a quick method of checking your settings, without having to switch on the receiving system. However,

this does not relieve you of the need to check all your programming steps carefully on the model before operating it for the first time, as this is the only safe method of excluding possible programming errors.

The display is based on the following scheme for fixed-wing models:

- Bar 1 = throttle / brake servo
- Bar 2 = aileron or left aileron
- Bar 3 = elevator
- Bar 4 = rudder
- Bar 5 = right aileron
- Bar 6 = (left) flap / free channel
- Bar 7 = right flap / free channel
- Bar 8 = free channel / second elevator servo

and for model helicopters:

- Bar 1 = collective pitch or roll (2) or pitch-axis (2) servo
- Bar 2 = roll (1) servo
- Bar 3 = pitch-axis (1) servo
- Bar 4 = tail rotor servo (gyro)
- Bar 5 = pitch-axis (2) servo / free channel
- Bar 6 = throttle servo or speed controller
- Bar 7 = gyro gain / free channel
- Bar 8 = speed governor / free channel

Note:

Please bear in mind that the servo display refers exclusively to the original servo sequence, i.e. it does NOT take into account any output swapping, as can be carried out in the “Receiver output” sub-menu in the “**Basic settings**” menu, page 60 / 69.

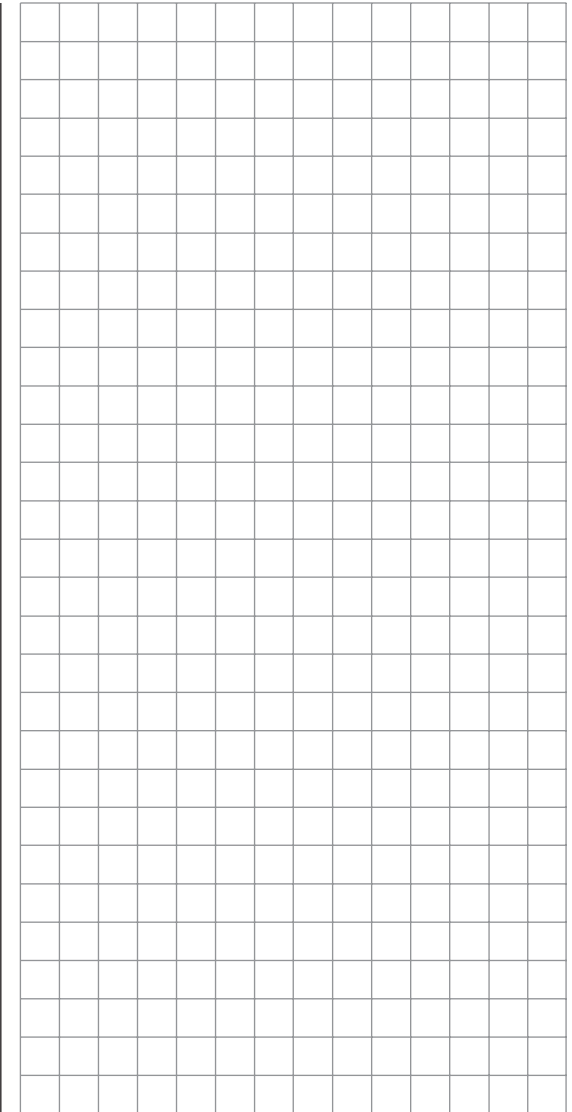



Basic settings

Use the arrow buttons of the left or right-hand touch-key to leaf through to the “**basic settings**” menu point of the multi-function menu:

mod. mem.	base sett.
servo set.	contr set.
D/R expo	phase trim
wing mixer	free mixer
servo disp	basic sett
fail-safe	telemetry

Touch the central **SET** button of the right-hand touch-key to open the menu point:

▶ Batt type	Ni-MH
Batt warning	4.7V
Touch Sense	2
Contrast	0
Display light	unlim
RF Country	Euro
Voice volume	3
Beep volume	3

In this menu you can enter basic settings which are specific to the transmitter.

Note:

Settings in this menu only need to be entered once, and apply to the whole transmitter. This means that the last valid settings always appear when you call up this menu from another model memory.

Use the arrow buttons ▲ ▼ of the left or right-hand touch-key to select the appropriate line, then touch the central **SET** button of the right-hand touch-key. The value field is now highlighted (black background), and you can use the arrow buttons of the right-hand touch-

key to alter the default value. Pressing the central **SET** button once more concludes the entry process.

Battery type

▶ Batt type	Ni-MH
Batt warning	4.7v
Touch Sense	2
Contrast	0
Display light	unlim

In this line you inform the transmitter whether its power is to be drawn from a four-cell NiMH battery or a single-cell LiPo battery. The voltage range offered in the (next) line “Battery warning threshold” will vary according to this setting.

Simultaneously pressing the arrow buttons ▲ ▼ or ◀ ▶ of the right-hand touch-key (**CLEAR**) resets the value in the highlighted field to NiMH.

Battery warning threshold

Batt type	Ni-MH
▶ Batt warning	4.7v
Touch Sense	2
Contrast	0
Display light	unlim

In this line you can enter any voltage you like ...

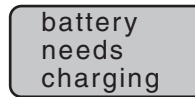

... within the range 4.5 to 5.5 V (NiMH battery) or 3.4 to 4.2 V (LiPo battery) - according to your choice of bat-

tery type - in increments of 0.1 Volt. However, never be tempted to enter too low a value here, to ensure that you always have ample time to land your model safely if a battery warning should be triggered.

Simultaneously pressing the arrow buttons ▲ ▼ or ◀ ▶ of the right-hand touch-key (**CLEAR**) resets the value in the highlighted field to 4.7 V or 3.4 V respectively.

Touch sensitivity

Batt type	Ni-MH
Batt warning	4.7v
▶ Touch Sense	2
Contrast	0
Display light	unlim

In this line you can select the touch sensitivity of the touch-keys within the range 1 to 10.

Simultaneously pressing the arrow buttons ▲ ▼ or ◀ ▶ of the right-hand touch-key (**CLEAR**) resets the value in the highlighted field to “2”.

Contrast

You can adjust the contrast of the **mx-16** HoTT’s integral screen to optimise its legibility in varying weather and temperatures:

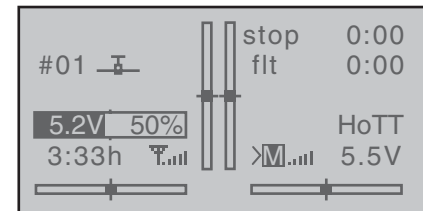

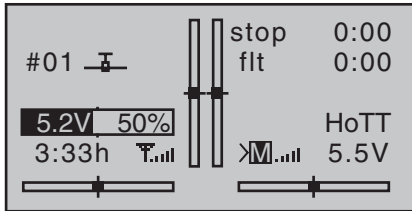

This is accomplished by selecting the “Contrast” line using the arrow buttons ▲▼ of the left or right-hand touch-key:



Now briefly touch the central **SET** button of the right-hand touch-key: the value field is now highlighted, and you can adjust the screen contrast within the range +/- 20 using the arrow buttons of the right-hand touch-key: Simultaneously pressing the arrow buttons ▲▼ or ◀▶ of the right-hand touch-key (**CLEAR**) resets the value in the highlighted field to “0”.

Screen backlight

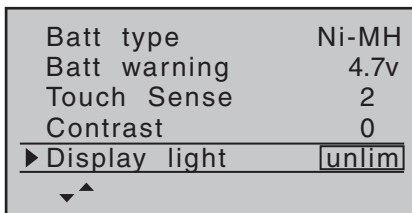

This line determines how long the screen backlighting

remains on when you switch the transmitter on, and after the last button-press.

The available values are “unlimited” “30 s”, 60 s” and “120 s”.

Simultaneously pressing the arrow buttons ▲▼ or ◀▶ of the right-hand touch-key (**CLEAR**) resets the value in the highlighted field to “unlimited”.

Country setting

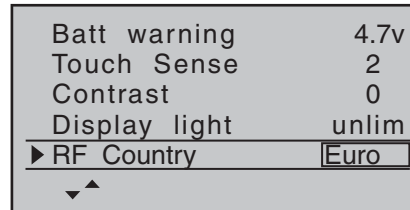

The purpose of the country setting is to fulfil the requirements of various directives (FCC, ETSI, IC, etc.). For example, radio control systems operated in France must be set to a restricted frequency band. For this reason **the transmitter’s country setting MUST be set to “France” mode before the system is used in that country.** It is prohibited to use the Universal / EURO mode in France.

Simultaneously pressing the arrow buttons ▲▼ or ◀▶ of the right-hand touch-key (**CLEAR**) resets the value in the highlighted field to “Euro”.

Voice volume

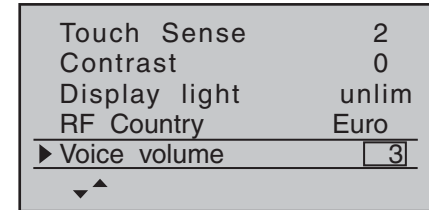

In this line you can define the volume of the speech output which is generated through earphones; the available range is “0” to “10”.

Simultaneously pressing the arrow buttons ▲▼ or ◀▶ of the right-hand touch-key (**CLEAR**) resets the value in the highlighted field to “3”.

Beep volume

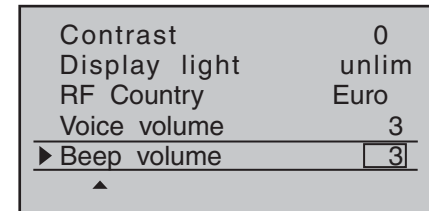

This line determines the volume of the transmitter’s internal sounder within the range “0” to “6”.

Simultaneously pressing the arrow buttons ▲▼ or ◀▶ of the right-hand touch-key (**CLEAR**) resets the value in the highlighted field to “4”.



Fail-Safe



The inherently higher operational security of the HoTT system compared with classic PPM technology is due to the ability of the HoTT receiver's integral micro-processor to process the signals from "its" transmitter exclusively, and also to process any "dirty" control signals which it picks up. The receiver constantly stores the latest valid signals, and invalid signals are automatically replaced by the stored signals - but only if the control signal is seriously inaccurate or even damaged, e.g. due to interference from an outside source. This process is dependent upon various settings which are described later in this section. For example, the receiver suppresses brief interference such as field strength "holes" and similar effects which would otherwise result in the familiar "glitches". When this happens, the red LED on the receiver lights up.

If you have not yet programmed any Fail-Safe settings in the currently active model memory, the following warning display will appear in the basic display for a few seconds when you switch the transmitter on:

fail safe
setup
t.b.d

Programming

The "Fail-Safe" function determines the receiver's behaviour when interference occurs in the transmission from

transmitter to receiver. The receiver outputs 1 ... 8 can optionally ...

1. maintain ("hold") their current position:

If interference should occur, all servos programmed to "hold" mode remain at the position last assessed by the receiver as correct until such time as a new, correct control signal arrives at the receiver, or

2. move to a user-selectable position ("Pos") if interference occurs, after a "delay" time has elapsed.

Use the arrow buttons ◀ ▶ of the left or right-hand touch-key to select the desired servo socket 1 to 8 (●), then touch the central **SET** button of the right-hand touch-key to switch between "hold" (■) and "position" (□) mode:

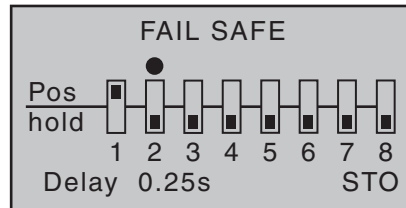

Now select the "Delay" option at bottom left of the screen using the arrow buttons ◀ ▶ of the left or right-hand touch-key ...

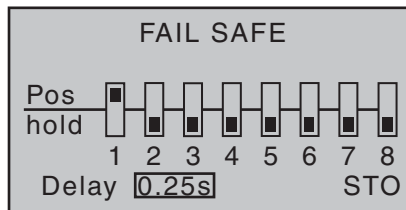

... touch the central **SET** button of the right-hand touch-key, and use its arrow buttons to select your preferred delay period from the four on offer (0.25 s, 0.5 s, 0.75 s

and 1 s).

Simultaneously pressing the arrow buttons ▲ ▼ or ◀ ▶ of the right-hand touch-key (**CLEAR**) resets the high-lighted field to the default value of 0.75 s.

Now use the arrow buttons ◀ ▶ of the left or right-hand touch-key to select the **STO** field at bottom right of the screen; SIMULTANEOUSLY move the servos for which you have selected Position mode to the desired positions using the associated transmitter controls.

A touch of the central **SET** button of the right-hand touch-key stores these positions in the receiver as the Fail-Safe settings, so that it can revert to these if interference should strike.

The transmitter informs you of the stored data by briefly displaying:

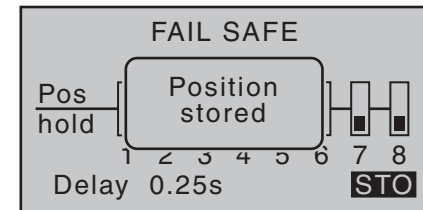

Caution:

We strongly recommend that you make use of the safety potential of this option by at least setting the throttle position (glow-powered models) to idle, or the electric motor to stop, if a fail-safe event should be triggered. Model helicopters should be programmed to "hold". This simple precaution ensures that the model is much less likely to cause havoc and cause property damage or personal injury.



Telemetry

The “**Telemetry**” menu is used to call up and program transmitter and receiver data, and data generated by optional telemetry sensors (see Appendix), in real time.

Note:

If you register your product under http://www.graupner.de/en/service/product_registration you will automatically be informed about new updates by e-mail.

Receiver data are transmitted to the transmitter via the HoTT receiver’s integral downlink channel. Please note the following important points in this regard:

Important information:

- These instructions cover the functions available at the time of going to press.
- As mentioned in the sections entitled “Binding multiple receivers” on pages 61 and 70, it is possible to bind more than one receiver per model. **However, in subsequent operations only the receiver which was bound last is able to make a telemetry connection to the transmitter.** On the other hand, this also means that only the last bound receiver can be addressed using the Telemetry menu. You may therefore need to change the binding sequence before you can enter settings which relate to a particular receiver.
- **When setting up the radio control system, please ensure at all times that the transmitter aerial is an adequate distance from the receiver aerials. A safe distance is about one metre. If you neglect this, you risk interference with the downlink channel, and consequent malfunctions.**
- Since the transmitter and receiver only exchange telemetry data after each fourth data packet, data transmission inevitably requires a certain amount of

time, which means that there will be some delay in responding to button-presses and set-up changes. This does not constitute an error.

- Changes to model and sensor programming must only be carried out when the model is on the ground. Do not make any alterations unless the motor is switched off and the flight battery is disconnected. If you ignore this, unwanted effects of programming changes cannot be excluded. For example, if you accidentally initiate an active servo test at the receiver, the model could crash and cause personal injury or property damage. Please see the Safety Notes on pages 3 ... 6 of this manual and the various individual instructions.
- All settings which you enter using the “**Telemetry**” menu, such as Fail-Safe, servo direction, servo travel, mixer and curve settings etc., are stored exclusively in the receiver, and are therefore carried over if you install the receiver in a different model. For this reason we strongly recommend that you re-initialise your HoTT receiver if you wish to use it in another model; see “Reset” on page 32 and 33.
- We therefore recommend that you program directions of servo rotation, servo travel, mixer and curve settings using only the **mx-16**-specific standard menus “**Servo settings**” (page 72), “**Free mixers**” (page 107) and “**D/R Expo**” (pages 82 and 84). If you ignore this, the settings may overlap and interfere with each other; in the most favourable case this can result in confusion when operating the model, and in the least favourable case it could cause problems.
- The channel-mapping function of the **mx-16** HoTT’s integral “**Telemetry**” menu can be used to share out control functions between multiple receivers

in any way, or even to assign the same control function to several receiver outputs; for example, you may wish to operate each aileron with two servos instead of just one, etc. **Once again we strongly recommend that you act as cautiously as possible when carrying out the programming.**

One telemetry sensor can be connected to the Telemetry input of the following receivers: GR-12S HoTT (Order No. **33505**), GR-12 HoTT (Order No. **33506**) and GR-16 (Order No. **33508**). Two telemetry sensors can be connected to the HoTT GR-24 HoTT receiver (Order No. **33512**).

Since the system can be updated by the user, the associated “**Telemetry**” menus can constantly be kept up-to-date, and expanded with the introduction of additional functions or languages in future.

Before updating the transmitter software you should always back up all occupied model memories to a compatible laptop or PC using a standard commercially available five-pole mini-USB lead, in order to avoid a possible loss of data.

In addition to the back-ups mentioned above, firmware updates are transferred using the mini-USB port located on the back of the transmitter, in conjunction with a PC running the Windows XP, Vista or 7 operating system.

The programs required for this and related information can be found in the Download area for the corresponding products at the website www.graupner.de. We always recommend that you load the latest firmware into your equipment, to ensure that your system is constantly kept up-to-date.

Telemetry

The menus grouped together under the overall heading “**Telemetry**” are called up from the basic display of the **mx-16** HoTT transmitter by holding the central **ESC** button of the left-hand touch-key pressed in for about three seconds. An alternative method of calling up this menu, which also applies to the transmitter’s other menus, is to briefly press the central **SET** button of the right-hand touch-key in the multi-function list:

mod. mem.	base sett.
servo set.	contr set.
D/R expo	phase trim
wing mixer	free mixer
servo disp	basic sett
fail-safe	telemetry

Basic menu operation

In general terms the “**Telemetry**” menu is operated just like the other menus of the **mx-16** HoTT transmitter. The few differences are described below:

You can switch between the individual pages of the Telemetry menu using the arrow buttons ◀ ▶ of the left or right-hand touch-key: you will find corresponding direction indicators at top right of every screen page in the form of angle brackets (< >); see illustrations. If only one angle bracket is visible, then you are currently at the first or last page. In this case it is only possible to switch pages in the direction indicated by the angle bracket. Menu lines in which parameters can be altered are marked with an angle bracket prefix (>). Pressing the arrow buttons ▲ ▼ of the left or right-hand touch-key causes the “>” pointer to jump forward or back by one line. Lines to which you cannot jump contain no user-variable values.

118 **Program description: Telemetry menu**

If you wish to change a parameter, touch the central **SET** button of the right-hand touch-key to highlight the parameter (black background)). Change the value within the possible range using the arrow buttons of the *right-hand* touch-key, and then press the **SET** button again briefly to accept the value.

The method of returning to the basic display varies depending on whether you called up the menu from the multi-function list or from the basic display: you can return to the basic display either by briefly pressing the **ESC** button again, or by holding **ESC** pressed in for about three seconds.

At this point you can use the arrow buttons ▲ ▼ of the left or right touch-key to select the desired sub-menu. However, if the message ...

CAN ' T
RECEIVE
DATA
OK

... appears instead of the desired sub-menu when you touch the central **SET** button of the right-hand touch-key, then the transmitter has no connection to a receiver. In this case, switch your receiving system on, or re-bind the receiver you wish to address, if this should not be the last bound one; see “Important information” on the previous page.

SETTING & DATA VIEW

SETTING & DATA VIEW

TELEMETRY
▶ SETTING & DATA VIEW
SIMPLE DATA VIEW
RF STATUS VIEW
VOICE TRIGGER

On the first screen page of the sub-menu “Setting & Data View”, headed ...

RX DATAVIEW

... you cannot enter any settings. This page is for information purposes only:

RX DATAVIEW >
S-QUA100% S-dBM-030dBm
S-STR100% R-TEM. +28°C
L PACK TIME 00010msec
R-VOLT : 05.0V
L. R-VOLT : 04.5V
SENSOR1 : 00.0V 00°C
SENSOR2 : 00.0V 00°C

Value	Explanation
S-QUA	Signal quality in %
S-dBm	Receive performance in dBm
S-STR	Signal strength in %
R-TEM.	Receiver temperature in °C
L PACK TIME	Indicates the time in ms for which the longest data packet was lost in transmission between transmitter and receiver
R-VOLT	Current receiver operating voltage, in Volt

L.R-VOLT	Lowest receiver operating voltage since the last power-on, in Volt
SENSOR1	Shows the values of the optional telemetry sensor 1 in Volt and °C
SENSOR2	Shows the values of the optional telemetry sensor 2 in Volt and °C

Signal quality (S-QUA)

The signal quality (S-QUA) is sent “live” to the transmitter via the receiver’s downlink channel, and shows the signal strength in %.

Receive performance (S-dBm)

The receive performance (S-dBm) is displayed as a negative value, i.e. a value approaching zero is the highest value (= best reception). The lower the value falls, the worse is the receive performance. This is an important item of information, particularly when you are carrying out a range-check before operating the model.

Note:

In the case of negative numbers the value is reversed: the higher the number following the minus sign, the lower the value.

Carry out a range-check as described on pages 62 and 70 before every flight, and remember to simulate all the servo movements which are likely to occur in the air. In active range-check mode the range must be at least fifty metres on the ground. To guarantee safe operation of your model, a value no higher than -80 dBm must be displayed in the “RX DATA” display under “S-dBm” at this distance. If the value falls below this (e.g. -85 dBm), you should under no circumstances fly your model. Instead check the receiving system installation and the aerial positions.

When operating a model this value should not fall below -90 dBm; if it does, reduce the distance between the pilot and the model. However, the audible range warning (beeping at one-second intervals) will normally be triggered before this value is reached, in order to ensure safe operation.

Signal strength (S-STR)

The value for signal strength (S-STR) is displayed in %. An audible range warning (beeping at one-second intervals) will always be generated as soon as the receiver signal in the downlink channel is too weak. However, since the transmitter has a much higher transmitting power than the receiver, the model can still be operated safely at this point. Nevertheless, in the interests of safety the distance to the model should be reduced until the audible warning ceases.

Receiver temperature (R-TEM.)

Ensure under all flight conditions that the receiver stays within its specified temperature range (ideally between -10 and +55°C).

The limit values for receiver temperature after which a warning occurs can be set in the “SERVO TEST” sub-menu under “ALARM TEMP+” (50 ... 80°C) and “ALARM TEMP-” (-20 ... +10°C). If the temperature exceeds or falls below the set limit, an audible signal (continuous beeping) is triggered, and “TEMPE” is displayed at top right in all the “RX” receiver sub-menus. At the same time the “R-TEM” parameter is highlighted on the “RX DATAVIEW” screen page.

Data packets (L PACK TIME)

This displays the longest period in ms in which data packets were lost in transmission from the transmitter to the receiver. In practice this means the longest time in

which the radio control system went into Fail-Safe mode.

Operating voltage (R-VOLT)

Check the receiver’s operating voltage constantly. If it is too low, you must under no circumstances continue to operate your model, and certainly not launch it. The low receiver voltage warning can be adjusted within the range 3.0 to 6.0 Volt in the “SERVO TEST” sub-menu under “ALARM VOLT”. If the voltage falls below the threshold, an audible signal (repeated double beep, long / short) is generated, and in all the receiver sub-menus “RX ...” you will see “VOLT.E” at top right. At the same time the parameter “R-VOLT” is highlighted in the “RX DATAVIEW” sub-menu.

The current receiver battery voltage is also shown in the basic display; see page 24.

Minimum operating voltage (L.R-VOLT)

“L.R-VOLT” shows the receiver’s minimum operating voltage since the last time it was switched on.

If this voltage differs significantly from the current operating voltage “R-VOLT”, this could mean that the receiver battery is being overstressed by the servos, causing collapses in battery voltage. If this should occur, we recommend installing a higher-performance receiver battery to ensure maximum operating safety.

Sensor 1 + 2

Shows the values of the optional telemetry sensor 1 and, if present, sensor 2 in Volt and °C. You will find a description of these sensors in the Appendix.

RX SERVO

```
RX SERVO <>
>OUTPUT CH : 01
REVERSE   : OFF
CENTER    : 1500µsec
TRIM      : -000µsec
TRAVEL-   : 150%
TRAVEL+   : 150%
PERIOD    : 20msec
```

Before you carry out any programming at this screen display be sure to read the information on page 117.

Value	Explanation	Possible settings
OUTPUT CH	Channel select	1 ... according to receiver
REVERSE	Servo reverse	OFF / ON
CENTER	Servo centre in µs	If active (high-lighted), according to transmitter control position
TRIM	Trim position in µs deviating from the CENTRE position	-120 ... +120 µs
TRAVEL-	Travel limitation at % servo travel	30 ... 150%
TRAVEL+	Travel limitation at % servo travel	30 ... 150%
PERIOD	Cycle time in ms	10 or 20 ms

OUTPUT CH (Channel select)

Select the "Channel" line if necessary using the arrow buttons. Touch the **SET** button of the right-hand touch-key to highlight the value field. Now use the arrow buttons of the right-hand touch-key to set the desired

channel (e.g. 01). **The following parameters always refer to the channel which you set at this point:**

REVERSE (servo reverse)

Sets the direction of rotation of the servo connected to the selected control channel: ON / OFF

CENTER (servo centre)

The "CENTRE" line displays the current pulse width in µs of the control channel selected in the "OUTPUT CH" line.

The displayed value varies according to the current position of the transmitter control which affects this control channel, and also its trim position.

A pulse width of 1500 µs corresponds to the standard centre position, and therefore the usual servo centre setting.

To change this value, select the "CENTRE" line and touch the **SET** button. Move the corresponding transmitter control to the desired position, and touch the **SET** button again to store the current transmitter control position. This position is now stored as the new neutral position.

TRIM (trim position)

The purpose of the "TRIM" line is to provide fine adjustment of the neutral position of a servo connected to the control channel selected in the "OUTPUT CH" line. Adjustments are made in 1 µs increments using the arrow buttons of the right-hand touch-key. The value in the "CENTRE" line can be adjusted over the range +/- 120 µs around the TRIM value set here.

Default setting: 0 µs

TRAVEL-/+ (servo travel -/+)

This option can be used to place a limit on servo travel

(control surface travel) for the servo connected to the control channel selected in the "OUTPUT CH" line. The value is set separately for each side of centre.

The setting can be altered separately for both directions within the range 30 ... 150%.

Default setting: 150% on both sides.

PERIOD (cycle time)

In this line you can determine the frame time for the individual channel signals. This setting applies to all control channels.

If you use digital servos exclusively, it is safe to set a cycle time of 10 ms.

If you are using a mixture of servo types, or exclusively analogue servos, it is essential to set 20 ms, otherwise the servos will be "over-stressed" and may respond by jittering or making rumbling noises.

RX FAIL SAFE

```
RX FAIL SAFE <>
>OUTPUT CH : 01
INPUT CH   : 01
MODE       : HOLD
F.S.Pos.   : 1500µsec
DELAY      : 0.75sec
FAIL SAFE ALL : NO
POSITION   : 1500µsec
```

Before we describe this menu a few words as a reminder:

"Doing nothing" is the worst thing you can do in this regard. The default setting for the HoTT receiver is "HOLD" mode.

If interference should occur with hold-mode in force, and if you are very lucky, the model aircraft will fly straight ahead for an indefinite period and then "land" some-

where or other without causing major damage. However, if the interference strikes in the wrong place and at the wrong time, then a power model could become uncontrollable and tear wildly across the flying field, endangering pilots and spectators.

For this reason you really must consider whether you should at least program the throttle to “motor stopped”, to avoid the worst of these risks.

After that warning we present a brief description of the three possible Fail-Safe variants offered by the **mx-16** HoTT transmitter:

The simplest way of setting Fail-Safe - and the one we recommend - is to use the “**Fail-Safe**” menu, which is accessed from the multi-function list; see page 116.

A similar alternative, albeit slightly more difficult to access, is to use the “FAIL-SAFE ALL” option described on the next double-page.

And finally there is the relatively complex method of entering individual settings using the “MODE”, “F.S.Pos.” and “DELAY” options. The description of this variant starts below with the “MODE” option.

Value	Explanation	Possible settings
OUTPUT CH	Output channel (receiver servo socket)	1 ... according to receiver
INPUT CH	Input channel (control channel coming from transmitter)	1 ... 16
MODE	Fail-Safe mode	HOLD FAIL SAFE OFF

F.S.Pos.	Fail-Safe position	1000 ... 2000 µs
DELAY	Response time (delay)	0,25, 0,50, 0,75 and 1,00 s
FAIL SAFE ALL	Stores fail-safe positions for all control channels	NO / SAVE
POSITION	Displays stored Fail-Safe position	between approx. 1000 and 2000 µs

OUTPUT CH (servo socket)

In this line you select the OUTPUT CH (receiver servo socket) which is to be adjusted.

INPUT CH (input channel select)

As already mentioned on page 117, the eight control functions of the **mx-16** HoTT transmitter can be shared out between several receivers if necessary, or alternatively several receiver outputs can be assigned to the same control function; for example, you may wish to be able to operate each aileron with two servos, or to control an oversized rudder using two coupled servos instead of a single one.

Sharing control functions amongst multiple HoTT receivers is a useful idea for large-scale models, for example, to avoid long servo leads. In this case bear in mind that only the last bound receiver can be addressed using the “**Telemetry**” menu.

The eight control channels (INPUT CH) of the **mx-16** HoTT can be managed in the appropriate manner using the facility known as “channel mapping”, i.e. by assigning a different control channel in the INPUT CH line to the receiver servo socket selected in the OUTPUT CH line. BUT CAUTION: if, for example, you have entered “2AIL” in the “Aileron/flap” line of the “**Basic settings**”

menu at the transmitter, then control function 2 (aileron) is already divided to control channels 2 + 5 for the left and right ailerons. The corresponding receiver INPUT CH, i.e. those to be mapped, would in this case be channels 02 + 05.

Examples:

- You wish to assign two or more servos to each aileron of a large-scale model aircraft:
Assign one and the same INPUT CH (control channel) to each of the appropriate OUTPUT CH (servo sockets). The appropriate servo sockets are selected for the left or right wing, while the INPUT CH will be one of the two default aileron control channels 2 + 5.
- You wish to control the rudder of a large-scale model aircraft using two or more servos:
Assign one and the same INPUT CH (control channel) to each of the appropriate OUTPUT CH (servo sockets); in this case the default rudder channel 4.

MODE

The settings you enter for the options “MODE”, “F.S.Pos.” and “DELAY” determine the receiver’s behaviour if interference should affect the transmission from transmitter to receiver.

The setting programmed under “MODE” *always* refers to the channel you have set in the OUTPUT CH line.

The default setting for all servos is “HOLD”.

For each selected OUTPUT CH (receiver servo socket) you can choose between:

- FAI(L) SAFE

If interference occurs, the corresponding servo moves to the position displayed in the “POSITION” line for the duration of the interference, after the “de-

lay time” set in the “DELAY” line.

- **HOLD**

If interference occurs, a servo set to “HOLD” maintains the position last assessed as correct for the duration of the interference.

- **OFF**

If set to “OFF” when interference occurs, the receiver continues to send the last correct control signals (which it has stored) to the corresponding servo output for the duration of the interference. This can be imagined as the receiver switching the signal wire “off”.

But CAUTION: if the control signal is absent, analogue servos and many digital servos offer no resistance to the forces acting on the control surfaces, with the result that the model’s control surface positions are more or less quickly lost.

F.S.Pos. (Fail-Safe position)

For each OUTPUT CH (receiver servo socket) activate (highlight) the value field by briefly pressing the central **SET** button of the right-hand touch-key, then use the arrow buttons of the right-hand touch-key in the “F.S.POS.” line to set the servo position which the servo is to take up in “FAIL-SAFE” mode if interference should occur. The setting can be entered in increments of 10 µs. Default setting: 1500 µs (servo centre)

Important note:

The “F.S.POS.” function is also significant if the receiver is switched on, but is (not yet) receiving a valid signal; this applies to all three modes “OFF”, “HOLD” and “FAIL-SAFE”:

The servo immediately runs to the Fail-Safe position previously set in the “Position” line. This can be exploited,

for example, to prevent the operation of a retractable undercarriage or similar function if the receiver is switched on accidentally. However, during normal model operations the corresponding servo behaves in accordance with the set “MODE” if interference should strike.

DELAY (fail-safe response time or delay)

At this point you can set the delay time after which the servos are to run to their previously selected positions if the signal should be interrupted. This setting applies to all channels, but only affects the servos programmed to “FAIL-SAFE” mode.

Default setting: 0.75 s

FAIL SAFE ALL (global fail-safe setting)

This sub-menu can be used to define the Fail-Safe position of the servos simply by “pressing a button”; it operates in a similar manner to the “Fail-Safe” menu described on page 116, and is simple to use:

Move to the “FAIL-SAFE ALL” line and press the central **SET** button of the right-hand touch-key to activate the value field; “**NO**” is highlighted (black background). Now set the parameter to “**SAVE**” using one of the arrow buttons of the right-hand touch-key. Use the transmitter controls to move all the servos which you have assigned - or intend to assign later - in the “MODE - FAIL-SAFE” line, to the desired fail-safe positions. In the extreme bottom line “Position” displays the current position of the transmitter control for the channel you have just set:

```
RX FAIL SAFE <>
>OUTPUT CH: 01
INPUT CH: 01
MODE : FAI - SAFE
F.S.Pos. : 1500µsec
DELAY : 0.75sec
FAIL SAFE ALL: SAVE
POSITION : 1670µsec
```

After touching the central **SET** button of the right-hand touch-key once more, the display reverts from “SAVE” to “NO”. This indicates that the position of all the servos affected by the procedure have now been stored, and have also been adopted in the “F.S.Pos.” line. At the same time the position for the current OUTPUT CH (servo socket) is immediately displayed on the screen.

```
RX FAIL SAFE <>
>OUTPUT CH: 01
INPUT CH: 01
MODE : FAI - SAFE
F.S.Pos. : 1670µsec
DELAY : 0.75sec
FAIL SAFE ALL: NO
POSITION : 1670µsec
```

Switch the transmitter off, and check the Fail-Safe positions by observing the servo movements.

“Fail-Safe” in combination with “channel mapping”

It is clearly desirable that mapped servos - i.e. servos which are controlled by a common control channel (INPUT CH) - should respond in the same way when interference occurs, so the corresponding settings of the INPUT CH determine the behaviour of mapped servos. For example, if receiver servo sockets 6, 7 and 8 are mapped together, i.e. if the same control channel “04” is assigned to OUTPUT CH (servo sockets) 06, 07 and 08 ...

```

RX FAIL SAFE <>
>OUTPUT CH: 06
INPUT CH: 04
MODE : OFF
F.S.Pos. : 1670µsec
DELAY : 0.75sec
FAIL SAFE ALL: NO
POSITION : 1670µsec

```

```

RX FAIL SAFE <>
>OUTPUT CH: 07
INPUT CH: 04
MODE : OFF
F.S.Pos. : 1230µsec
DELAY : 0.75sec
FAIL SAFE ALL: NO
POSITION : 1670µsec

```

```

RX FAIL SAFE <>
>OUTPUT CH: 08
INPUT CH: 04
MODE : HOLD
F.S.Pos. : 1770µsec
DELAY : 0.75sec
FAIL SAFE ALL: NO
POSITION : 1670µsec

```

... then INPUT CH 04 determines the Fail-Safe behaviour of the three servos connected to control channel 4, regardless of the individual settings of the OUTPUT CH for INPUT CH 04:

```

RX FAIL SAFE <>
>OUTPUT CH: 04
INPUT CH: 04
MODE : FAIL-SAFE
F.S.Pos. : 1500µsec
DELAY : 0.75sec
FAIL SAFE ALL: NO
POSITION : 1500µsec

```

This also applies, for example, if it is mapped in turn to INPUT CH 01:

```

RX FAIL SAFE <>
>OUTPUT CH: 04
INPUT CH: 01
MODE : FAIL-SAFE
F.S.Pos. : 1500µsec
DELAY : 0.75sec
FAIL SAFE ALL: NO
POSITION : 1500µsec

```

In this case servo socket 04 would respond in accordance with the Fail-Safe settings for CH 01.

In contrast, the response or delay time set in the “DELAY” line always applies uniformly to all channels which are set to “FAIL-SAFE”.

RX FREE MIXER

```

RX FREE MIXER <>
>MIXER : 1
MASTER CH: 00
SLAVE CH : 00
S-TRAVEL-: 100
S-TRAVEL+: 100
RX WING MIXER
TAIL TYPE: NORMAL

```

Value	Explanation	Possible settings
MIXER	Mixer select	1, 2 or 3
MASTER CH	Primary channel	0, 1 ... 8
SLAVE CH	Secondary channel	0, 1 ... according to receiver
S-TRAVEL-	Negative mix value	0 ... 100%
S-TRAVEL+	Positive mix value	0 ... 100%

RX WING MIXER	Tail type	NORMAL, V-TAIL ELEVON (aileron / elevator mixer for deltas and flying wings)
---------------	-----------	---

MIXER

Up to three mixers can be programmed simultaneously. You can switch between mixer 1, mixer 2 and mixer 3 using “MIXER”.

The following settings on this screen *always* apply to the mixer selected in the MIXER line.

Important note:

If you have already programmed mixer functions in the “Wing mixers” or “Free mixers” menus, check very carefully that those mixers do not overlap with those of the “RX FREE MIXER” menu.

MASTER CH (“from”)

The signal present at the MASTER CH (master channel) is mixed into the SLAVE CH (slave channel) to a user-variable extent, following the same principles as described in detail in the section entitled “Free mixers” on page 107.

Select “00” if no mixer is to be set.

SLAVE CH (“to”)

A proportion of the signal of the MASTER CH (primary channel) is mixed into the SLAVE CH (secondary channel); the mixer ratio is determined by the percentage figures entered in the “TRAVEL-” and “TRAVEL+” lines. Select “00” if no mixer is to be set.

TRAVEL-/+ (mixer ratio in %)

The mixer ratio in relation to the MASTER signal is

determined separately for each direction by the values entered in these two lines.

TAIL TYPE

The following model types are also available in the “Tail” line of the “Basic settings” menu (see page 58), and should normally be set up at that point. If you have done this, you should *always* leave the TAIL TYPE at NORMAL.

However, if you prefer to use the receiver’s integral mixers, you can select the pre-set mixer function for the corresponding model type:

- **NORMAL**

This setting corresponds to the classic aircraft type with tail-mounted stabiliser panels and separate rudder and elevator. No mixer function is required for this model type.

- **V-TAIL**

For this model type the control functions elevator and rudder are linked together in such a way that each of the two control surfaces - actuated by a separate servos - carries out superimposed elevator and rudder functions.

The servos are usually connected to the receiver as follows:

OUTPUT CH 3: left V-tail servo

OUTPUT CH 4: right V-tail servo

If you find that the servos rotate in the wrong direction, please see the notes on page 44.

- **ELEVON (delta / flying wing models)**

The servos connected to outputs 2 and 3 assume superimposed aileron and elevator functions. The servos are usually connected to the receiver as follows:

OUTPUT CH 2: left elevon

OUTPUT CH 3: right elevon

If you find that the servos rotate in the wrong direction, please see the notes on page 44.

RX CURVE (EXPO)

```

RX CURVE <>
> CURVE1 CH : 02
      TYPE  : B
  CURVE2 CH : 03
      TYPE  : B
  CURVE3 CH : 04
      TYPE  : B
  
```

Value	Explanation	Possible settings
CURVE1, 2 or 3 CH	Channel assignment of the selected curve setting	1 ... according to receiver
TYPE	Curve type	A, B, C see illustration

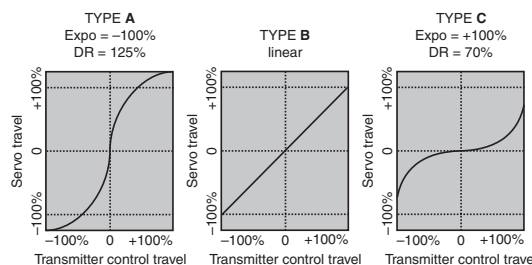

In most cases a non-linear control function is used for aileron (channel 2), elevator (channel 3) and rudder (channel 4), and the default settings assume that this is the case. **BUT CAUTION:** this assignment only applies if you have not set either “2 ELE Sv” in the “Tail” line of the “Basic settings” menu, or “2AIL” or “2AIL 2FL” in the “Ail / flap” line, at the transmitter. Otherwise *control function*

3 (elevator) is already split over control channels 3 + 8, and control function 2 (aileron) is split over control channels 2 + 5 for the left and right ailerons. In both these cases the corresponding receiver control channels (INPUT CH) would then be channels 03 + 08 or 02 + 05.

For example, if you have set “2AIL” at the transmitter, and wish to use the RX CURVE option discussed here instead of the “D/R Expo” menu (see page 82) of the **mx-16** HoTT transmitter - which offers more individual adjustment options - then two curves must be set:

```

RX CURVE <>
> CURVE1 CH : 02
      TYPE  : A
  CURVE2 CH : 05
      TYPE  : A
  CURVE3 CH : 04
      TYPE  : B
  
```

If you ignored this, the left and right ailerons would exhibit different control characteristics.

The RX CURVE function can be used to manage the control characteristics for up to three servos:

- **CURVE 1, 2 or 3 CH**

Select the desired control channel (INPUT CH) for the first servo.

The following setting in TYPE only affects the channel you select at this point.

TYPE

Select the servo curve:

A: EXPO = -100% and DUAL RATE = 125%

The servo responds slowly to stick movements around the neutral position, but the curve becomes steeper with increasing control travel.

B: Linear setting

The servo follows the stick movement with a linear response.

C: EXPO = +100% and DUAL RATE = 70%

The servo responds slowly to stick movements around the neutral position, but the curve becomes steeper with increasing control travel.

Note:

The control characteristics programmed at this point also affect mapped receiver outputs.

RX SERVO TEST

```

RX SERVO TEST <
>ALL-MAX : 2000µsec
ALL-MIN : 1000µsec
TEST : STOP
ALARM VOLT : 3.8V
ALARM TEMP+ : 70°C
ALARM TEMP- : -10°C
CH OUTPUT TYPE : ONCE
  
```

Value	Explanation	Possible settings
ALL-MAX	Pre-set maximum servo test travel for all servo outputs	1500 ... 2000 µs
ALL-MIN	Pre-set minimum servo test travel for all servo outputs	1500 ... 1000 µs
TEST	Test procedure	START / STOP
ALARM VOLT	Alarm limit for the receiver low-voltage warning	3,0 ... 6,0 V Default setting: 3,8 V

ALARM TEMP+	Alarm limit for excessive receiver temperature	50 ... 80 °C Default setting: 70 °C
ALARM TEMP-	Alarm limit for excessively low receiver temperature	-20 ... +10 °C Default setting: -10 °C
CH OUTPUT TYPE	Channel sequence	ONCE, SAME, SUMI, SUMO

ALL MAX (maximum servo travel)

In this line you can set the maximum servo travel for the servo test on the plus side of control travel.

2000 µs corresponds to full travel, 1500 µs corresponds to the neutral position.

ALL MIN (minimum servo travel)

In this line you can set the maximum servo travel for the servo test on the minus side of control travel.

1000 µs corresponds to full travel, 1500 µs corresponds to the neutral position.

TEST

In this line you can start and stop the receiver's integral servo test.

Touch the central **SET** button of the right-hand touch-key to activate the input field:

```

RX SERVO TEST <
ALL-MAX : 2000µsec
ALL-MIN : 1000µsec
>TEST : STOP
ALARM VOLT : 3.8V
ALARM TEMP+ : 70°C
ALARM TEMP- : -10°C
CH OUTPUT TYPE : ONCE
  
```

Now select **START** with one of the arrow buttons of the right-hand touch-key:

```

RX SERVO TEST <
ALL-MAX : 2000µsec
ALL-MIN : 1000µsec
>TEST : START
ALARM VOLT : 3.8V
ALARM TEMP+ : 70°C
ALARM TEMP- : -10°C
CH OUTPUT TYPE : ONCE
  
```

Touch the central **SET** button of the right-hand touch-key to start the test-run. The input field now reverts from highlighted to "normal":

```

RX SERVO TEST <
ALL-MAX : 2000µsec
ALL-MIN : 1000µsec
>TEST : START
ALARM VOLT : 3.8V
ALARM TEMP+ : 70°C
ALARM TEMP- : -10°C
CH OUTPUT TYPE : ONCE
  
```

To stop the servo test, re-activate the input field as described previously, then select **STOP** and confirm your choice with the **SET** button of the right-hand touch-key.

ALARM VOLT (low receiver voltage warning)

ALARM VOLT monitors the receiver voltage. The threshold can be set to any value within the range 3.0 to 6.0 Volt. If the voltage falls below the set alarm limit, an audible signal (interval beeping, long / short) is triggered, and "VOLT.E" flashes at top right in all "RX ..." screen displays:

```
RX SERVO      VOLT.E <>
> OUTPUT CH : 01
REVERSE      : OFF
CENTER       : 1500µsec
TRIM         : -000µsec
TRAVEL-      : 150%
TRAVEL+      : 150%
PERIOD       : 20msec
```

The parameter **R-VOLT** is also highlighted in the "RX DATAVIEW" display:

```
RX DATAVIEW >
S-QUA100%S-dBM-030dBm
S-STR100% R-TEM.+28°C
L PACK TIME 00010msec
R-VOLT : 05.0V
L. R-VOLT : 04.5V
SENSOR1 : 00.0V 00°C
SENSOR2 : 00.0V 00°C
```

ALARM TEMP +/- (receiver temperature monitor)

These two options monitor the temperature of the receiver: a lower limit value "ALARM TEMP-" (-20 ... +10°C) and an upper limit value "ALARM TEMP+" (50 ... 80°C) can be programmed. If the temperature exceeds the upper limit or falls below the lower one, an audible signal (continuous beeping) is triggered, and "TEMP.E" appears at top right in all receiver displays. The parameter **R-TEM** is also highlighted in the "RX DATAVIEW" display.

Ensure that the receiver remains within the permitted

temperature range under all flight conditions (ideally between -10 and +50°C).

CH OUTPUT TYPE

At this point you can select how the receiver outputs are to be addressed.

• ONCE

The receiver servo sockets are addressed in sequence; this is recommended for use with analogue servos. At this setting the servos are automatically operated at a frame rate of 20 ms (30 ms with the twelve-channel receiver, Order No. **33512**) - regardless of what is set or displayed in the "PERIOD" line of the "RX SERVO" display.

• SAME

The receiver servo sockets are addressed in parallel blocks of four, i.e. channels 1 to 4 and channels 5 to 8 each receive their control signals simultaneously.

This is recommended for use with digital servos, and especially where multiple servos are employed for a single function (e.g. ailerons), to ensure that the groups of servos run absolutely synchronously.

If you are using digital servos, we recommend that you set 10 ms in the "PERIOD" line of the "RX SERVO" display so that you can exploit the fast response of these servos. If you are using analogue servos, it is essential to select "20 ms".

If you choose the faster setting, please take particular care when selecting the receiver power supply: since up to four servos can start moving simultaneously, the load on the battery is fairly severe, so it must be a high-performance type.

• SUMI / SUMO (sum signal IN / OUT)

The HoTT transmission system allows a single trans-

mitter to control more than one receiver: either in "Master - Slave" arrangement, or in "Satellite mode", as described here.

In ...

Satellite mode

... two HoTT receivers are inter-connected using a three-core connecting lead (Order No. **33700.1** (300 mm) or **33700.2** (100 mm) by the highest-numbered servo sockets. For more details on this please visit www.graupner.de on the Internet.

The HoTT receiver which is configured as SUMO (see below) is designated the satellite receiver, and all its channels are transmitted in the form of a sum signal to the second HoTT receiver - the primary receiver - if reception should fail; the primary receiver must be programmed as "SUMI". Note that the signal only ever moves towards SUMI.

The receiver outputs are addressed in sequence at a frame rate of 20 ms (30 ms with the GR-24 receiver, Order No. **33512**), even if you have set 10 ms in the "PERIOD" line of the "RX SERVO" screen page.

However, if the receiver programmed as the satellite (SUMO) suffers signal reception failure, the servos connected to that receiver take up the Fail-Safe positions programmed in the satellite receiver, regardless of the primary receiver.

This receiver configuration is recommended in particular circumstances: for example, if one of the two receivers has to be installed in an unfavourable position in the model, or if there is a danger that the received signal will be weak in certain flight attitudes, perhaps due to a turbine, carbon fibre in the airframe, or a similar problem, with the result that sporadic range

SIMPLE DATA VIEW

problems might be expected.

For this reason it is essential to connect the most important control functions to the primary receiver (the one programmed as SUMI), so that interference to the satellite receiver (SUMO) does not cause the model to go out of control.

Telemetry data, such as the voltage of the airborne power supply, are only sent to the transmitter by the satellite receiver (configured as SUMO), i. e. all telemetry sensors must be connected to the satellite receiver (SUMO).

Each receiver should be connected to the shared power supply using its own power lead. If high currents can be expected, duplicated power connections are recommended. However, if each of the two receivers is to be powered by its own battery, then it is essential to withdraw the central (red) wire from one of the two satellite lead connectors, as shown in the illustration.

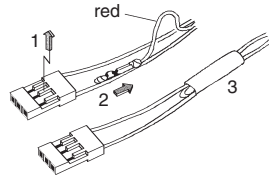

If you wish to carry out further programming, such as the Fail-Safe settings, disconnect the three-core satellite connection between the two receivers, and switch on just the receiver you wish to address. Note that you may also need to change the binding sequence.

SIMPLE DATA VIEW

Select the desired menu line using the arrow buttons ▲ ▼ of the left or right-hand touch-key ...

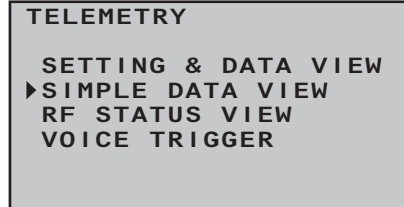

... and then briefly press the central **SET** button of the right-hand touch-key to bring up a list of further sub-menus.

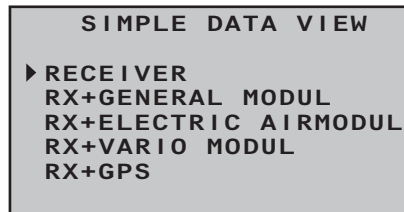

RECEIVER

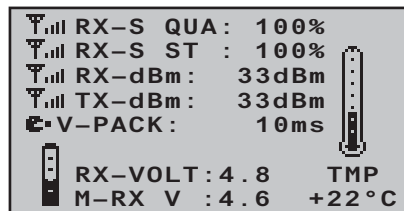

This screen displays the data which can also be viewed in the “RX DATAVIEW” screen of the telemetry menu “SETTING & DATA VIEW”, but in graphic form.

The meanings are as follows:

Value	Explanation
RX-S QUA	Signal quality in %
RX-S ST	Signal strength in %
RX-dBm	Receive performance in dBm
TX-dBm	Transmit power in dBm
V PACK	shows the longest period in ms in which data packets were lost in transmission from transmitter to receiver
RX-VOLT	Current receiver operating voltage in Volt
M-RX V	Lowest receiver operating voltage in Volt since the last time it was switched on
TMP	The thermometer indicates the receiver's current operating temperature

RX + GENERAL MODUL

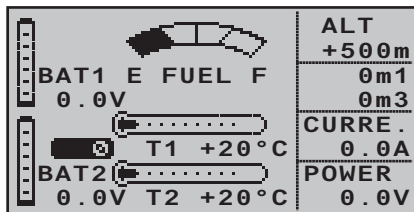
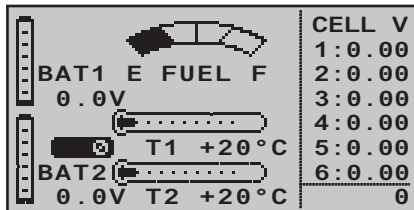

If a General Engine module, Order No. **33610**, or a General Air module, Order No. **33611**, is connected to the receiver, then this screen provides a graphic display of the data supplied by it. For more information on these modules please see the Appendix, or refer to the product on the Internet at www.graupner.de.

Depending on the types of sensor fitted to the modules, the display constantly shows the following data:

The actual voltage of up to two rechargeable batteries (BAT1 and BAT2); the measured values from up to two temperature sensors (T1 and T2) and a fueltank level indicator.

At the right-hand edge the screen shows either an alternating list of the actual cell voltages of a LiPo battery with up to six cells, or the current altitude relative to the location, climb / descent in m/1sec and m/3sec, current in Ampere plus the actual voltage of the battery connected to the sensor.

The meanings are as follows:

Value	Explanation
BAT1 / BAT2	Battery 1 / Battery 2
FUEL	Fuel level / Fueltank indicator
E / F	Empty / full
T1 / T2	Temperature of sensor 1 / sensor 2
CELL V	Cell voltage of cell 1 ... max. 6
ALT	Current altitude
0m1	m/1 sec climb / descent
0m3	m/3 sec climb / descent
CURRE.	Actual current in Ampere
POWER	Actual voltage of drive battery

RX + ELECTRIC AIRMODUL

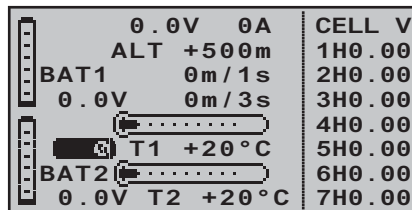
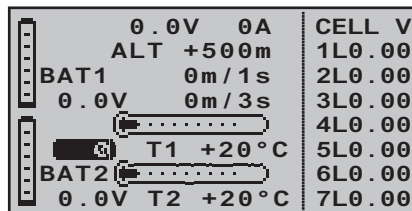

If an Electric-Air module, Order No. **33620**, is connected to the receiver, then this screen provides a graphic display of the data supplied by it. For more information

on this module please see the Appendix, or refer to the product on the Internet at www.graupner.de.

Depending on the types of sensor fitted to the module, the display constantly shows the following data:

The actual voltage of up to two rechargeable batteries (BAT1 and BAT2); the measured values from up to two temperature sensors (T1 and T2); the current altitude relative to the location, and the climb / descent of the model in m/1sec and m/3sec; the centre of the screen also displays the current actually being drawn from a power source.

At the right-hand edge the screen shows an alternating display of the actual cell voltages of the battery packs (max. seven cells each) connected to balancer sockets 1 (L) or 2 (H).

The meanings are as follows:

Value	Explanation
V	Actual voltage
A	Actual current
BAT1 / BAT2	Battery 1 / Battery 2
ALT	Current altitude
m/1s	m/1 sec climb / descent
m/3s	m/3 sec climb / descent
T1 / T2	Temperature from sensor 1 / 2
CELL.V	Cell voltage of cell 1 ... max. 14
L	Balancer socket 1
H	Balancer socket 2

RF STATUS VIEW

RF STATUS VIEW

Select the desired menu line with the arrow buttons ▲ ▼ of the left or right-hand touch-key ...

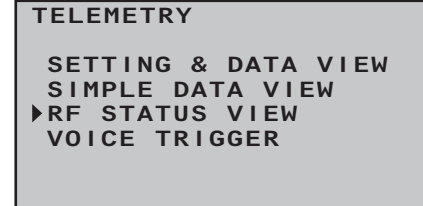

... and then press the central **SET** button of the right-hand touch-key to open the selected sub-menu:

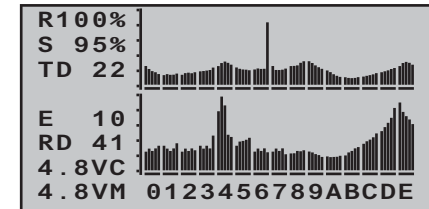

Top row: receive performance in dBm of channels 1 ... 75 on the 2.4 GHz band.

Bottom row: receive performance in dBm of the signal of channels 1 ... 75 on the 2.4 GHz band, as picked up by the receiver.

This screen provides a graphic display of data showing the occupation of the 2.4 GHz band.

As well as the graphic depiction of band occupation, additional numeric information is generated to the left of the graphs. The meanings are as follows:

Value	Explanation
R	Signal quality in % for the signal arriving from the receiver

RX + VARIO

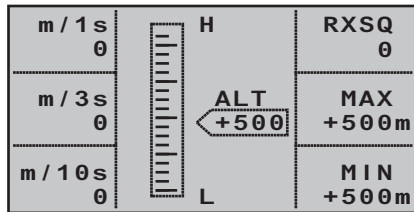

If a Vario module, Order No. **33601**, is connected to the receiver, then this screen provides a graphic display of the data supplied by it. For more information on this module please see the Appendix or refer to the product on the Internet at www.graupner.de.

The meanings are as follows:

Value	Explanation
ALT	Current altitude
RXSQ	Signal strength of the signal picked up by the receiver in %
MAX	The pre-set altitude limit relative to the launch point; above this altitude the transmitter emits audible warning signals
MIN	The pre-set altitude limit below the launch point; below this altitude the transmitter emits audible warning signals
m/1s	m/1 sec climb / descent
m/3s	m/3 sec climb / descent
m/10s	m/10 sec climb / descent

RX + GPS

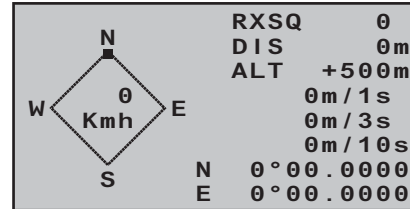

If a GPS module with integral vario, Order No. **33600**, is connected to the receiver, then this screen provides a graphic display of the data supplied by it. For more information on this module please see the Appendix, or refer to the product on the Internet at www.graupner.de.

The centre of the screen shows the current positional data and the model's speed; the display also shows the model's current altitude in relation to the launch point, its climb / descent rate at m/1 sec, m/3 sec and m/10 sec, the current reception quality and the model's range from the launch point.

The meanings are as follows:

Value	Explanation
W / N / E / S	West / North / East / South
Kmh	Speed
RXSQ	Signal strength of downlink channel
DIS	Distance
ALT	Current altitude relative to launch point
m/1s	m/1 sec climb / descent
m/3s	m/3 sec climb / descent
m/10s	m/10 sec climb / descent

VOICE TRIGGER

Value	Explanation
S	Signal quality in % for the signal arriving at the receiver
TD	Reception performance in dBm
E	Number of lost receiver data packets
RD	Reception performance in dBm of the signal picked up by the receiver
VC	Actual receiver operating voltage in Volt
VM	Lowest receiver operating voltage in Volt since the last time it was switched on

VOICE TRIGGER

First select the desired menu line using the arrow buttons ▲ ▼ of the left or right-hand touch-key ...

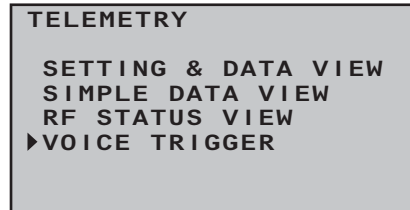

... then press the central **SET** button of the right-hand touch-key to open the selected sub-menu:

REPEAT

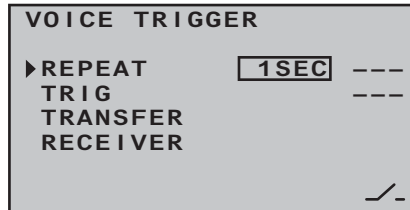

Speech output is available via the headphone socket, but not until you have at least assigned a switch in the “REPEAT” line. This is accomplished as described in the section entitled “Assigning switches and control switches” on page 39:

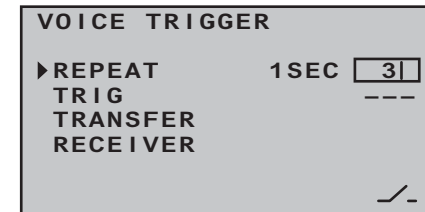
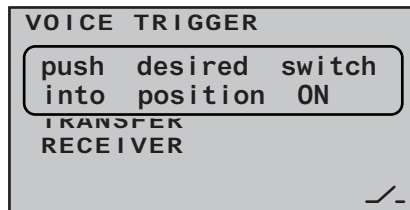

All the time the assigned switch is closed, the last speech output is repeated for the period set to the left of the switch.

TRIG

If you assign a switch in the “TRIG” line - preferably one of the two momentary buttons SW 1 or SW 9 - you can use it to cycle through the speech output selected in the menus described in the following section.

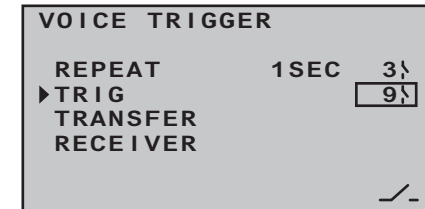

TRANSFER

Select the desired menu line using the arrow buttons ▲ ▼ of the left or right-hand touch-key ...

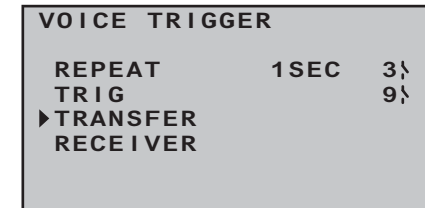

... then briefly press the central **SET** button of the right-

hand touch-key to open the selected sub-menu:

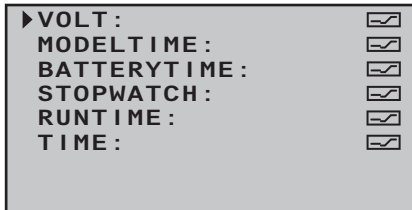

In this menu you can select and de-select the chosen speech output after using the arrow buttons ▲▼ of the left or right-hand touch-key to select the desired line, followed by a brief press of the central **SET** button of the right-hand touch-key:

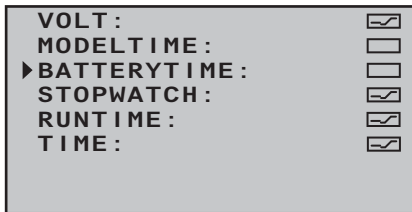

RECEIVER

Select the desired menu line with the arrow buttons ▲▼ of the left or right-hand touch-key ...

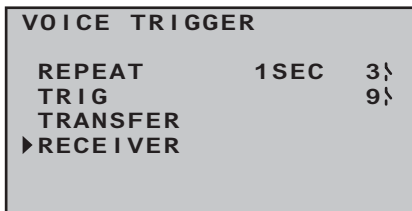

... then touch the central **SET** button of the right-hand touch-key to call up the selected sub-menu:

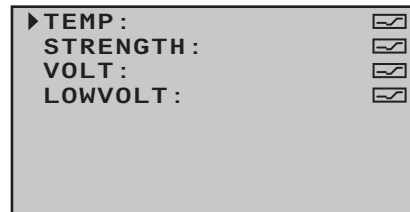

In this menu you can select and de-select the chosen speech output after using the arrow buttons ▲▼ of the left or right-hand touch-key to select the desired line, followed by a brief press of the central **SET** button of the right-hand touch-key:

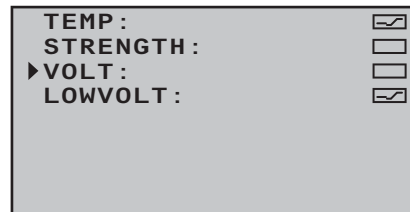

SENSOR

This line only appears if you have already activated one of the "RX ..." sub-menus of the "SIMPLE DATA VIEW" menu, and then returned directly to the "VOICE TRIGGER" menu:

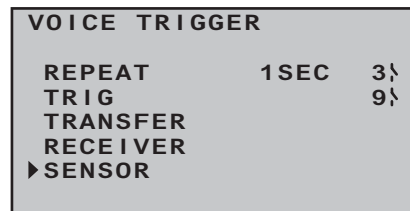

For example, if you selected the "RX + VARIO" option, then selected the "SENSOR" line and touched the central **SET** button of the right-hand touch-key, you will see

the display shown below:

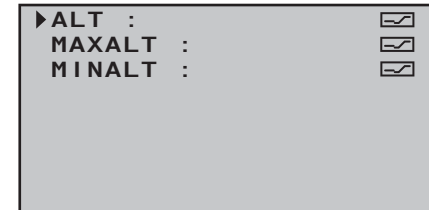

As described in the left-hand column, you can also select or de-select any available speech output by briefly pressing the central **SET** button of the right-hand touch-key after you have selected the desired line.



Trainer Mode

Connecting two transmitters for trainer mode operations using a Trainer lead

Use the arrow buttons of the left or right-hand touch-key to leaf through to the “Trainer” menu point of the multi-function menu:

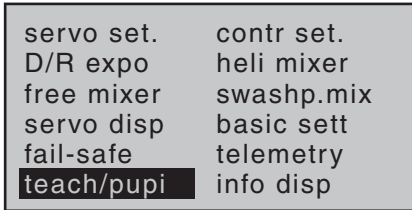
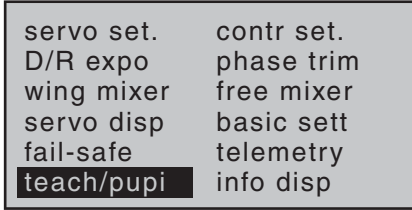

Touch the central **SET** button of the right-hand touch-key to open the menu:

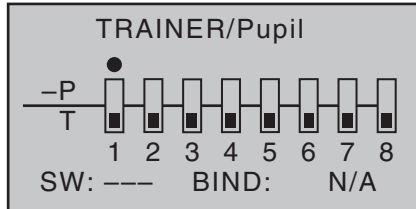

The illustration above shows the initial state of this menu: transmitter controls have not been released (□) to the pupil, and a switch has not been assigned (SW: --- at bottom right and -P on the left of the display).

Teacher transmitter settings

Up to eight *transmitter control functions* of the Teacher transmitter “T” can be transferred individually or in any combination to the pupil transmitter “P”.

The lower line of the display marked “T” therefore indicates those **transmitter controls** which are permanently connected to the inputs 1 ... 4 (dual-axis stick functions, fixed-wing model and model helicopter), plus the transmitter controls CTRL 6 to 8, which can be assigned to inputs 5 ... 8 in the “**Transmitter control settings**” menu.

Notes:

- This means that the three-position switches SW 4/5 and 6/7, designated CTRL 9 and 10, explicitly **CAN NOT** be transferred.
- Transmitter controls can only be assigned in the “**Transmitter control settings**” menu when the Trainer connection is switched off.

Use the arrow buttons ◀ ▶ of the left or right-hand touch-key to select the *transmitter controls* 1 to 8 (●) to be transferred to the pupil, and briefly press the central **SET** button of the right-hand touch-key in each case, so that they switch from “T (Teacher)” (□) to “P (Pupil)” (■):

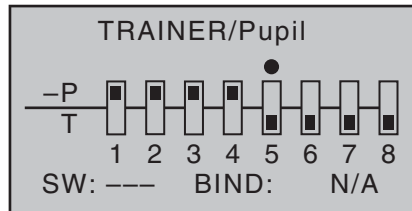

You still have to assign a Trainer transfer switch on the right of the screen so that you can actually transfer control to the Pupil. This is accomplished by using the arrow

buttons of the left or right-hand touch-key to place the marker next to “SW” at bottom right, and assign a switch as described on page 39.

We recommend that you use one of the two momentary switches SW 1 or SW 9 as the transfer switch, to ensure that the Teacher transmitter can regain control instantly at any time.

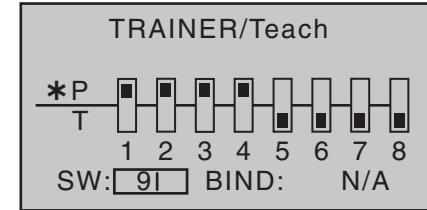

Note:

The switch assignment procedure described above determines which transmitter provides the Teacher function, and which provides the Pupil function. For this reason a switch must **NEVER** be assigned to the Pupil transmitter in this menu. **To underline this, the menu headline switches from “TRAINER / pupil” to “TRAINER / teacher” as soon as a switch is assigned.**

The model to be controlled by the pupil *must* be programmed *completely* in a model memory of the **mx-16** HoTT Teacher transmitter, i.e. with all its functions including trims and any mixer functions. The HoTT receiver in the model must also be “bound” to the Teacher transmitter, since it is this transmitter which actually controls the model in Pupil mode, even in Trainer operations.

The **mx-16** HoTT Teacher transmitter **MUST ALWAYS BE SWITCHED ON FIRST. ONLY THEN MAY THE CONNECTING LEAD BE PLUGGED INTO IT.** If you

neglect this, the RF module will not be activated.

The **mx-16** HoTT Teacher transmitter can be linked to any suitable Pupil transmitter - even those operating on the "classic" 35 / 40 MHz band. For example, an **mx-16** HoTT Teacher transmitter can certainly be used in conjunction with an **mx-16(s)** Pupil transmitter.

However, if the connection at the pupil end is NOT made using a two-pole DSC socket, but instead - for example - using a three-pin Trainer socket from the *Graupner* range, the **basic requirement for a correct connection with a Pupil transmitter is that PPM (18 or 24) modulation must ALWAYS be set on the Pupil transmitter, regardless of the modulation used by the Teacher transmitter.**

Pupil transmitter settings

The model to be controlled by the pupil *must* be programmed *completely* in a model memory of the Teacher transmitter, i. e. with all its functions including trims and any mixer functions, and the HoTT receiver in the model must be "bound" to the *Teacher* transmitter. In principle, however, an **mx-16** HoTT Pupil transmitter can also be linked to a Teacher transmitter operating on the "classic" 35 / 40 MHz band, since the PPM signal required from the Teacher transmitter is present at the transmitter's DSC socket.

The Pupil transmitter can be virtually any transmitter from the former and current *Graupner* range with at least four control functions. More information on this is available in the main FS catalogue, and on the Internet under www.graupner.de.

Some transmitters will need to be retro-fitted with the appropriate module in order to act as the Pupil transmitter.

This should be connected to the transmitter circuit board as described in the installation instructions supplied in the set. Information on the Pupil module required can be found in the main *Graupner* FS catalogue and on the Internet at www.graupner.de.

The Pupil transmitter must be connected to the Teacher transmitter using the appropriate lead - see next double page. **The control functions of the Pupil transmitter MUST act directly on the control channels, i. e. the receiver outputs, without the intervention of any mixers.**

If you are using an "mc" or "mx" series transmitter, it is best to set up a free model memory in the Pupil transmitter with the required model type ("Fixed-wing" or "Helicopter"). Assign the model name "Pupil" to the memory, and set up the stick mode (Mode 1 ... 4) and "Throttle min. forward / back" to suit the pupil's preference. All the other settings should be left at the appropriate default values. If you select the "Helicopter" model type, the throttle / collective pitch direction and idle trim must also be set accordingly on the Pupil transmitter. All other functions, including mixer and coupling functions, are carried out by the Teacher transmitter, which transmits them to the receiver in the model.

If you are using a "D" or "FM" type transmitter, you should check the servo directions and stick mode, and alter them by re-connecting the appropriate leads if required. All mixers should be switched off or set to "zero". When assigning the control functions the usual conventions should be observed:

Channel	Function
1	Throttle / Collective pitch
2	Aileron / Roll

3	Elevator / Pitch-axis
4	Rudder / Tail rotor

If you wish to transfer other control functions to the Pupil transmitter, in addition to the functions of the two dual-axis sticks (1 ... 4), then you will need to assign additional transmitter controls in the Pupil transmitter's "Transmitter control settings" menu to those inputs which correspond to transmitter control numbers 5 ... 8, as released in the Teacher transmitter's "Trainer" menu.

Important:

- **If you forget to assign a transmitter control, then the servo or servos concerned will remain in the centre position when control is transferred to the Pupil transmitter.**
- **The Pupil transmitter must always be operated in PPM mode, regardless of the type of RF link between the Teacher transmitter and the model.**
- **If the Pupil transmitter is connected using a DSC socket, then you should ALWAYS leave the Pupil transmitter's On / Off switch at the "OFF" position, as this is the only way to ensure that the Pupil transmitter module does not generate an RF signal even when the DSC lead is plugged in.**

Trainer mode operations

Connect the two transmitters using the appropriate lead; see the overview on the next page: connect the plug marked "M" (Master) to the socket on the Teacher transmitter, and the plug marked "S" (Student) (not present on all leads) to the appropriate socket on the Pupil transmitter.

Trainer mode operations with the **mx-16** HoTT transmitter

Due to the constant expansion of our range of products please visit the Internet at www.graupner.de for the latest information.

mx-16 HoTT Pupil transmitter

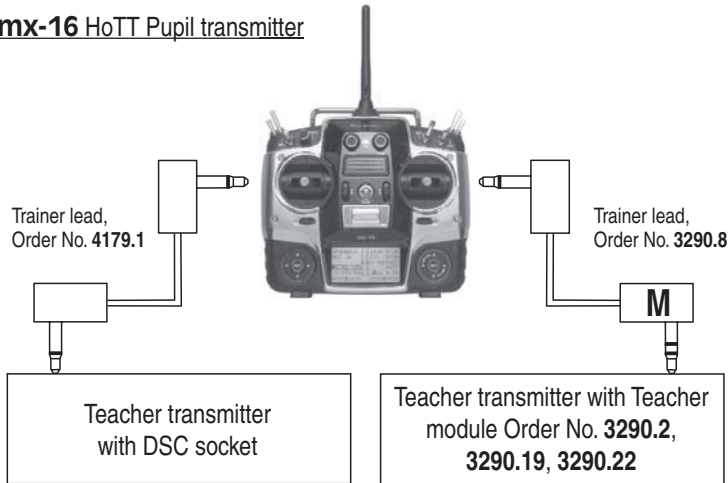

mx-12(s)HoTT, **mx-16s**/iFS/
HoTT, **mx-22**(iFS), **mx-24s** and,
if fitted with DSC socket, Order No.
3290.24, **mc-19**(s + iFS), **mc-22**(s
+ iFS) and **mc-24**

mc-19 to **mc-24**, **mx-22**(iFS),
mx-24s

mx-16 HoTT Teacher transmitter

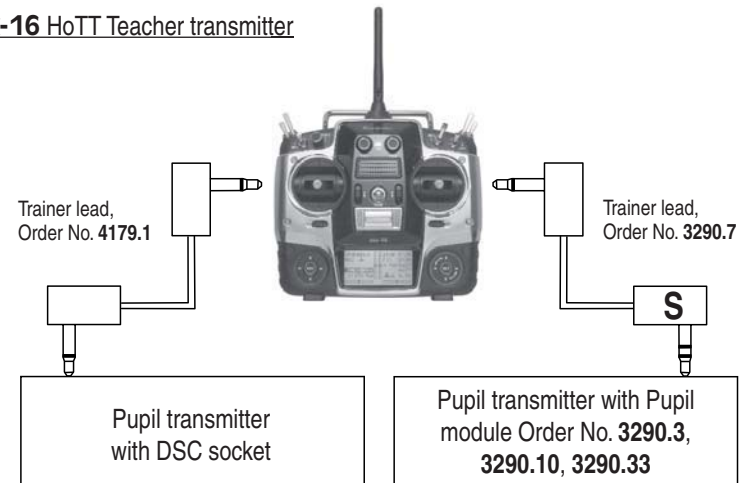

mx-12(s)HoTT, **mx-16s**/iFS/
HoTT, **mx-22**(iFS), **mx-24s** and,
if fitted with DSC socket, Order
No. **3290.24**, **mc-19**(s + iFS),
mc-22(s + iFS) and **mc-24**

D 14, FM 414, FM 4014, FM 6014,
mc-10 ... **mc-24**, **mx-22**(iFS),
mx-24s

Note:

These lists represent the transmitters and transmitter combinations which are possible at time of going to press.

Wireless HoTT system

Two HoTT transmitters can also be combined by wireless means to form a Trainer system as an alternative to the “classic” system using a Trainer lead, as described on the preceding pages.

Preparations

The trainer model must be programmed completely, i.e. with all its functions including trims and any mixer functions, both in a model memory of the **mx-16** HoTT Pupil transmitter and also in the **mx-16** HoTT Teacher transmitter. **This means that it must be possible to control the trainer model fully, without restriction, by both transmitters, i.e. by the Teacher and the Pupil transmitters.** It is very important to avoid any major set-up differences, otherwise there is a risk that the servos will jump abruptly from one position to another when control is transferred between the Teacher and Pupil transmitters, which can place a severe strain on the servos. Nevertheless, it may be sensible to program smaller control surface travels on the Pupil model at least, as this makes it easier to learn the basic skills of model flying.

Once both transmitters are prepared for training operations as described above, **the trainer model should be bound to the Pupil transmitter.** A detailed description of the binding procedure can be found on pages 61 and 70.

Binding the Teacher and Pupil transmitters

Switch both transmitters on, and use the arrow buttons of the left or right-hand touch-key to leaf through on both transmitters to the “Trainer” menu point of the multi-function menu. (The trainer model’s receiving system, previously bound to the Pupil transmitter, does not need to be switched on during the following procedure.)

servo set.	contr set.
D/R expo	phase trim
wing mixer	free mixer
servo disp	basic sett
fail-safe	telemetry
teach/pupi	info disp

servo set.	contr set.
D/R expo	heli mixer
free mixer	swashp.mix
servo disp	basic sett
fail-safe	telemetry
teach/pupi	info disp

Touch the central **SET** button of the right-hand touch-key to open the following menu point:

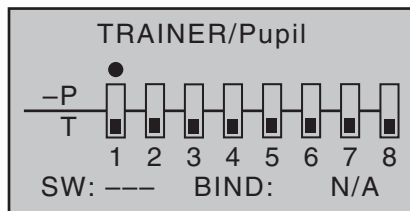

The illustration above shows the initial state of this menu: no transmitter controls have been released to the Pupil (●), and no switches have been assigned (SW: --- bottom right and -S on left of illustration).

Pupil transmitter

Use the arrow buttons of the left or right-hand touch-key to move the marker / cursor to the input field marked “Bind”. If a switch is displayed adjacent to “SW” on the right, then it is essential to erase this: see the following illustration:

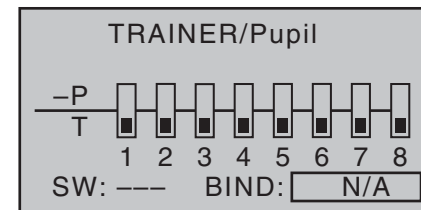

Teacher transmitter

Touch the central **SET** button of the right-hand touch-key to release the control channels to be transferred to the Pupil. When you do this, the corresponding symbol changes from □ to ■. For example:

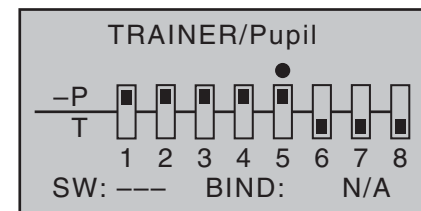

Important Note:

In contrast to the wired Trainer system described in the previous section, in which TRANSMITTER CONTROL SIGNALS are released to the Pupil exclusively, it is CONTROL CHANNELS which are transferred when using the wireless HoTT system which is described in this section.

For example, if the aileron function (2) is to be transferred, and if the model is equipped with two aileron servos which are usually connected to receiver sockets 2 and 5, then in the wireless system control channels 2 and 5 must also be transferred, and not just - as with the wired system - number 2; see illustration above. The same applies to flap servos connected to 6 and 7 (“2AIL

2FL" setting in the "Basic settings" menu), or two elevator servos connected to 3 and 8 ("2Sv EL" setting in the "Basic settings" menu).

You still have to assign a Trainer transfer switch on the right of the screen so that you can actually transfer control to the Pupil. This is accomplished by using the arrow buttons of the left or right-hand touch-key to place the marker next to "SW" at bottom right, and assign a switch as described on page 39.

We recommend that you use one of the two momentary switches SW 1 or SW 9 as the transfer switch, to ensure that the Teacher transmitter can regain control instantly at any time.

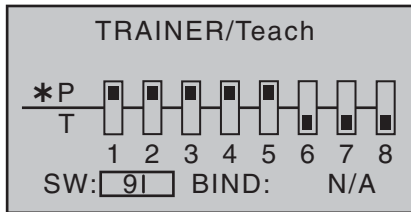

Note:
The switch assignment procedure described above determines which transmitter provides the Teacher function, and which provides the Pupil function. For this reason a switch must NEVER be assigned to the Pupil transmitter in this menu. **To underline this, the menu headline switches from "TRAINER / pupil" to "TRAINER / teacher" as soon as a switch is assigned.**

Now use the arrow buttons of the left or right-hand touch-key to move the marker to "BIND: N/A" on the right:

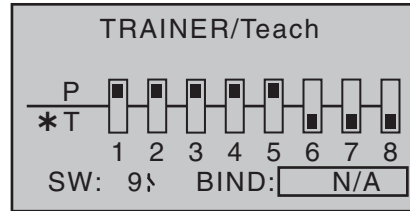

Binding the Pupil transmitter to the Teacher transmitter

Note:
During the binding procedure the distance between the two transmitters should not be too great. You may need to change the relative position of the two transmitters and initiate the binding process a second time.

If necessary, close the Trainer transfer switch which you have just assigned ...

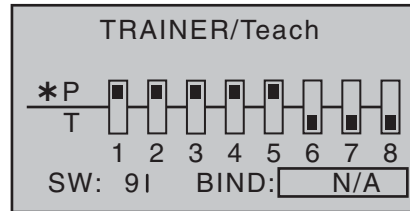

... and start the "BINDING" process first at the Pupil transmitter by briefly pressing the central **SET** button of the right-hand touch-key ...

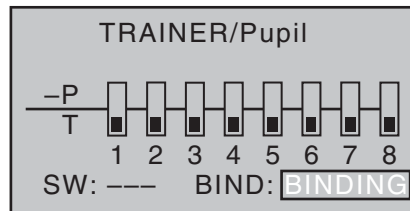

... and immediately afterwards that of the Teacher transmitter:

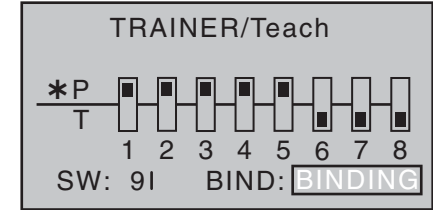

As soon as this process is concluded, both screens display "ON" instead of the flashing message "BINDING":

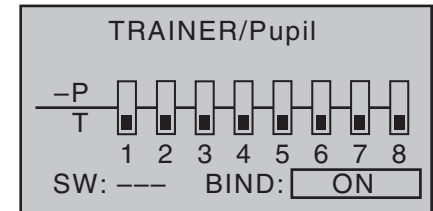
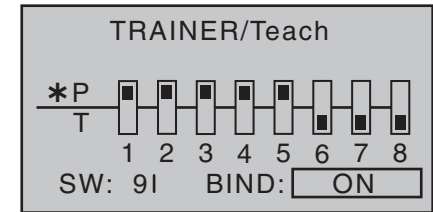

This concludes the binding process, and you can return to the basic display of both transmitters, and start trainer mode operations - once you have checked the operation of all the functions.

However, if neither transmitter, or only one of the transmitters, displays "ON", indicating that the binding procedure has failed, try changing the relative position of the two transmitters, and repeat the whole procedure.

During ...

Trainer mode operations

... it is no problem for the Teacher and Pupil to stand a little way apart. However, you should never exceed a distance of 50 m (this is known as the call range), and no other persons should stand between the Teacher and Pupil, as this could reduce the effective range. Please note also that the wireless Trainer function exploits the downlink connection, and for this reason no telemetry data are transmitted from the model in this mode.

In this mode of operation the basic display of the Teacher transmitter looks like this ...

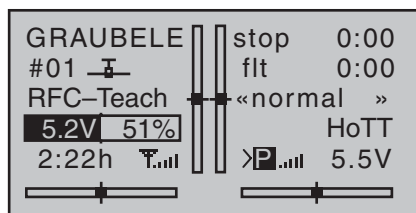

... and that of the Pupil transmitter typically like this:

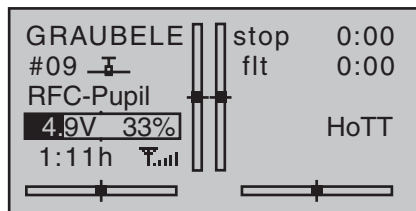

If it should occur that the link between the Teacher and Pupil transmitters is lost during Trainer mode operations, note that the Teacher transmitter automatically assumes control of the model.

In this situation, if the Trainer change-over switch is in the "Pupil" position, then the central LED on the Teacher transmitter starts to flash blue / red for the duration of the signal loss, and the transmitter emits audible warn-

ing signals. At the same time "RFC-" flashes in the basic display, and the following warning is displayed:



However, if only "RFC-" flashes in the basic transmitter display, and - relatively quiet - audible signals are heard ...

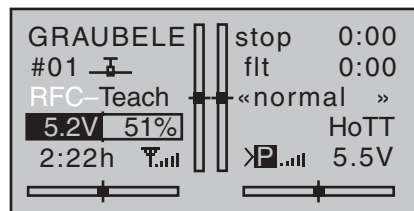

... then this indicates that the Pupil signal has also been lost, but the Trainer transfer switch is in the "Teacher" position.

In either situation your first recourse should be to reduce the distance between the two transmitters. If this does not help, land the model immediately, and seek the cause.

However, if both transmitters are operating with the receiving system switched off, then the "familiar" ∞ symbol appears in the basic display of the Teacher transmitter instead of the two ... symbols.

Resuming Trainer mode operations

If - for whatever reason - one or both transmitters are switched off during a Trainer mode session, then the screen displays the following query when the transmitter or transmitters are switched on again:



Touch the central **SET** button of the right-hand touch-key to confirm "ACT(ivate)", or alternatively wait for about two seconds until the message disappears; the last link you created with a Teacher or Pupil transmitter is now restored.

However, if you select "INH(hibit)" using one of the arrow buttons of the left or right-hand touch-key ...



... and confirm your choice by briefly pressing the central **SET** button of the right-hand touch-key, this resets that transmitter to "normal" operation. In this case you will have to repeat the binding process with a Teacher or Pupil transmitter as and when required.

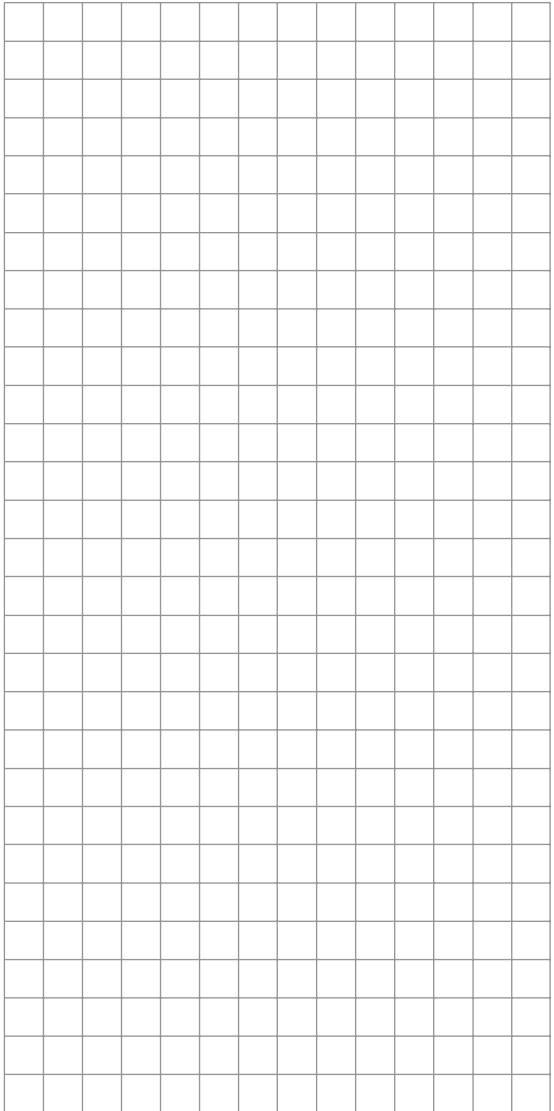
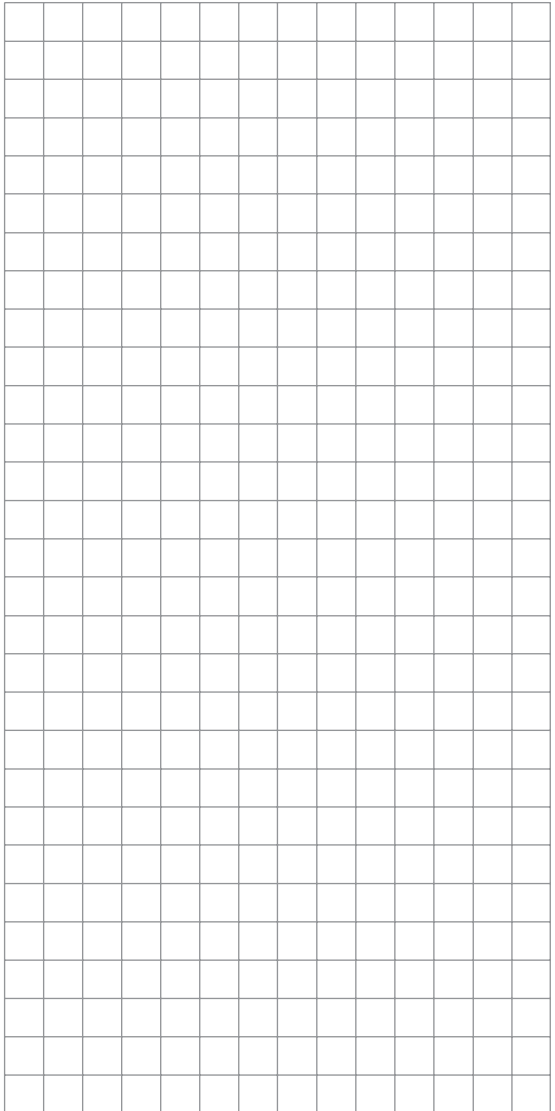
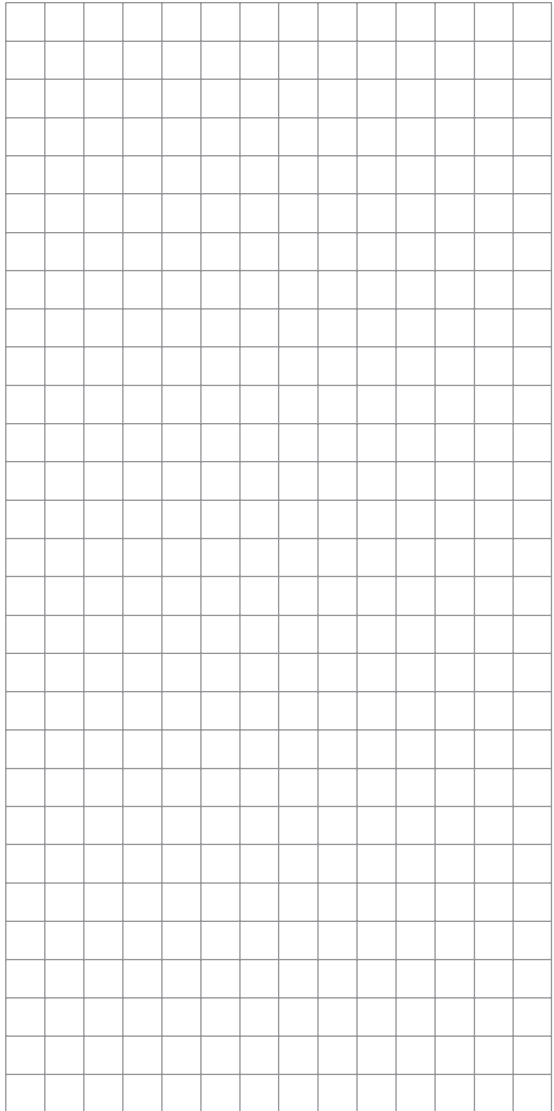



Info Display

Date, time, transmitter ID and memory card

Use the arrow buttons of the left or right-hand touch-key to leaf through to the "Info" menu point of the multi-function menu:

servo set.	contr set.
D/R expo	phase trim
wing mixer	free mixer
servo disp	basic sett
fail-safe	telemetry
teach/pupi	info disp

servo set.	contr set.
D/R expo	heli mixer
free mixer	swashp.mix
servo disp	basic sett
fail-safe	telemetry
teach/pupi	info disp

Touch the central **SET** button of the right-hand touch-key to open the menu point:

▶RFID	ABCDEF12
firmware ver.	1.11
date	2011/03/11(FRI)
time	11:22:33s
SD-CARD	0KB
available	0KB
	0%

This menu displays transmitter-specific information, some of which can be altered where necessary and sensible.

Use the arrow buttons ▲▼ of the left or right-hand touch-key to select the appropriate line, then touch the central **SET** button of the right-hand touch-key. In the

highlighted value field you can now alter the default value using the arrow buttons of the right-hand touch-key, and conclude your input with a further touch of the central **SET** key.

RFID

▶RFID	ABCDEF12
firmware ver.	1.11
date	2011/03/11(FRI)
time	11:22:33s
SD-CARD	0KB

This line displays the transmitter's identification number. This number is specific to the transmitter, and is only issued once for each transmitter. During the binding process this ID is transmitted to the receiver (amongst other data), so that it is able at any time to identify the radio signals of "its" transmitter.

Version

RFID	ABCDEF12
▶firmware ver.	1.11
date	2011/03/11(FRI)
time	11:22:33s
SD-CARD	0KB

This line displays the version number of the transmitter software currently installed.

By comparing the number shown here with the update version available for the same product on the Internet at www.graupner.de you can judge whether an update to the transmitter's operating system is necessary and useful.

In some circumstances our Service department may also ask you for the version number.

Date

RFID	ABCDEF12
firmware ver.	1.11
▶date	2011/03/11(FRI)
time	11:22:33s
SD-CARD	0KB

If necessary, select this line using the arrow buttons ** of the left or right-hand touch-key, then select the month or day field. A brief press of the central **SET** button of the right-hand touch-key activates the corresponding value field, and you can then set the year, month or day using the arrow buttons of the right-hand touch-key. A further brief press of the central **SET** button of the right-hand touch-key concludes the input process. The available range of years runs from 2000 to 2135.

The weekday, shown in brackets at far right in abbreviated form, is automatically generated from the date.

Notes:

- The date and time of day can also be set using the PC program available for the corresponding product on the Internet at www.graupner.de; this requires that the transmitter should be connected to a PC in the appropriate manner.
- The date and time are protected from data loss due to power failure - for example, when the battery is swapped - by a user-replaceable buffer battery.

Time

RFID	ABCDEF12
firmware ver.	1.11
date	2011/03/11(FRI)
▶time	11:22:33s
SD-CARD	0KB
▼▲	

If necessary, you can select this line, and the minutes field, using the arrow buttons of the left or right-hand touch-key. A brief press on the central **SET** button of the right-hand touch-key activates the corresponding value field, and you can then adjust the hours or minutes using the arrow buttons of the right-hand touch-key. A further brief press on the central **SET** button of the right-hand touch-key concludes the entry process.

Note that the seconds display cannot be set directly; instead it can be reset to “00” with a touch of the central **SET** button of the right-hand touch-key.

Notes:

- The date and time of day can also be set using the PC program available for the corresponding product on the Internet at www.graupner.de; this requires that the transmitter should be connected to a PC in the appropriate manner.
- The date and time are protected from data loss due to power failure - for example, when the battery is swapped - by a user-replaceable buffer battery.

SD card

RFID	ABCDEF12
firmware ver.	1.11
date	2011/03/11(FRI)
time	11:22:33s
▶SD-CARD	2048KB
▼▲	

This line displays the storage capacity in KB of a memory card installed in the transmitter.

Depending on the memory capacity of the micro-SD or micro-SDHC memory card fitted in the transmitter, it may take several minutes for the display to show the correct value after you switch the transmitter on.

available

firmware ver.	1.11
date	2011/03/11(FRI)
time	11:22:33s
SD-CARD	2048KB
▶available	1234KB
▼▲	

Display of the available memory in KB.

As already mentioned, it may take a certain amount of time for the available memory to be displayed after you switch the transmitter on, depending on the total capacity of the installed memory card.

The next line down displays the available memory in relation to the total memory capacity:

date	2011/03/11
time	11:22:33s (FRI)
SD-CARD	2048KB
available	1234KB
▶	60%
▲	

As already mentioned, it may take a certain amount of time for the available memory to be displayed after you switch the transmitter on, depending on the total capacity of the installed memory card.

mx-16 HoTT programming techniques

Preparation, using a fixed-wing model aircraft as an example

Programming model data into an mx-16 HoTT is easier than it might appear at first sight.

There is one basic rule which applies equally to all programmable radio control transmitters, and not just to the **mx-16** HoTT: if the programming is to go “smoothly” and the systems work as expected, the receiving system components must first be installed correctly in the model, i. e. the mechanical systems must be first-rate. This means: ensure that each servo is at its correct neutral position when you fit the output lever or disc and connect the linkage to it. If you find this is not the case, correct it! Remove the output arm, rotate it by one or more splines and secure it again. If you use a servo tester, e. g. the RC-Tester, Order No. **2894.12**, to centre the servos, you will find it very easy to find the “correct” position.

Virtually all modern transmitters offer facilities for offsetting the neutral position of servos, but this is no substitute for a correct mechanical installation; this function is only intended for *fine tuning*. Any substantial deviation from the “0” position may result in additional asymmetry when the signal undergoes further processing in the transmitter. Think of it this way: if the chassis of a car is distorted, you may be able to force the vehicle to run straight by holding the steering wheel away from centre, but it does not make the chassis any less bent, and the basic problem remains.

Another important point is to set up the correct control travels wherever possible by using the appropriate linkage points in the mechanical system; this is much more efficient than making major changes to the travel settings at the transmitter. The same rule applies: electronic travel adjustment facilities are designed primarily to compensate for minor manufacturing tolerances in the

servos and for *fine adjustment*, and not to compensate for poor-quality construction and defective installation methods.

If two separate aileron servos are installed in a fixed-wing model aircraft, the ailerons can also be employed as flaps by deflecting both of them down, and as air-brakes by deflecting both of them up - simply by setting up a suitable mixer (see the section starting on the next double page). Such systems are generally more often used in gliders and electric gliders than in power models.

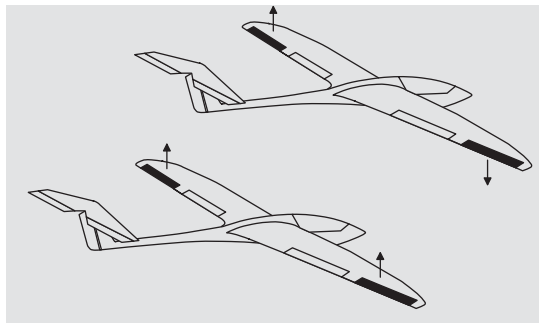

In such cases the servo output arms should be offset forward by one spline relative to the neutral point, i. e. towards the leading edge of the wing, and fitted on the servo output shaft in that position.

The mechanical differential achieved by this asymmetrical installation takes into account the fact that the braking effect of the up-going ailerons increases with their angle of deflection, and this means that much less travel is usually required in the down-direction than the up-direction.

Similar reasoning applies to the installation of the flap linkage when separately actuated flap servos are installed, designed to be used in a butterfly (crow) system. Here again an asymmetrical linkage point is useful. The

braking effect of the crow system is provided primarily by the down-movement of the flaps rather than the up-movement of the ailerons, so in this case the servo output arms should be angled aft, i. e. offset towards the trailing edge of the wing, as this makes greater travel available for the down-movement. When this combination of lowered flaps and raised ailerons is used, the ailerons should only be raised by a moderate extent, as their primary purpose in this configuration is to stabilise and control the model rather than act as brakes.

You can “see” the difference in terms of braking effect by deploying the crow system, then looking over and under the wing from the front: the larger the projected area of the deflected control surfaces, the greater the braking effect.

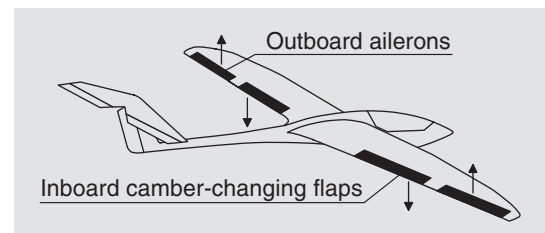

(This type of asymmetrical installation of the servo output arms can also make sense when you are setting up split flaps or landing flaps on a power model.)

Once you have completed your model and set up the mechanical systems accurately in this way, you are ready to start programming the transmitter. The instructions in this section are intended to reflect standard practice by describing the basic general settings first, and then refining and specialising them to complete the set-up. After the initial test-flight, and in the course of continued test-flying, you may need to adjust one or oth-

er of the model's settings. As your piloting skills improve and you gain experience, it is very likely that you will feel the need to try out refinements such as expanded control systems, and to cater for these requirements you may find that the text deviates from the obvious order of options, or that one or other of the options is mentioned more than once.

On the other hand, it can certainly occur that not every step described in these instructions is relevant to a particular model, just as some users might miss the description of a particular step which is relevant to his model only ...

Regardless of all this, it is worthwhile thinking carefully about a sensible layout of the transmitter controls at this point, just before you start programming the model data.

If the model in question is one with the emphasis on "power" - whether the power of an electric motor or internal-combustion engine (glow motor) - you will probably encounter few problems in this matter, because the two stick units are primarily employed to control the four basic functions "power control (= throttle)", "rudder", "elevator" and "aileron". Nevertheless, you still have to call up the ...

"Basic settings" menu (pages 56 ... 62)

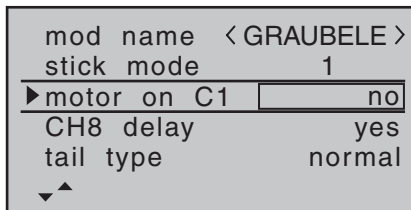

... and define your preferred throttle direction, i.e. throttle minimum forward ("Idle forward") or back ("Idle

back"), because the program's default setting is "none" (i.e. no motor) when you first set up a model memory. The basic difference between "none" or "none/inv" and "throttle min. forward / back" is the effect of the Ch 1 trim. The trim is effective over the full stick travel if "none (/inv)" is entered, but it only affects the idle range if you enter "throttle min. forward or back". However, it also affects the "direction of effect" of the Ch 1 stick, i.e. if you switch from "forward" to "back" or vice versa, you do not also have to reverse the direction of the throttle (or brake) servo. For safety reasons you will also see a warning message, and hear an audible warning, if you switch the transmitter on with the throttle stick positioned towards "full-throttle" - but only if you have already set "throttle min. forward or back".

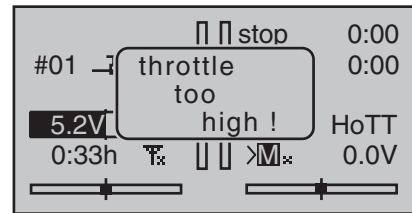

Your choice of "none" (no motor) or "throttle min. forward or back" also affects the range of mixers available in the "Fixed-wing mixers" menu. The mixers "Brake → NN*" are only present if you choose "none" (no motor) or "none/inv"; otherwise they are suppressed.

In addition to these basic matters you will certainly need to consider carefully how best to control any "auxiliary functions" present on your model.

In contrast, if your model is a glider or electric glider the whole situation may be rather different. The immediate question is: what is the best way of operating the motor

* NN = Nomen Nominandum (name to be stated)

and braking system? Now, some solutions have proved to be practical, and others less so.

For example, it is not a good idea to be forced to let go of one of the primary sticks in order to extend the airbrakes or deploy the crow braking system when your glider is on the landing approach. It surely makes more sense to set up switchable functions for the Ch 1 stick (see example 4 on page 150), or to assign the braking system to the throttle stick, and shift the motor control to a slider - or even a switch. With this type of model the electric motor is often little more than a "self-launching system", and is used either to haul the model into the sky at full power, or to pull it from one area of lift to the next at, say half-power, and for such models a three-position switch is usually quite adequate. If the switch is positioned where you can easily reach it, then you can turn the motor on and off without having to let go of the sticks - even on the landing approach.

Incidentally, similar thinking can be applied to flap control systems, regardless of whether they are "just" the ailerons, or full-span (combination) control surfaces which are raised and lowered in parallel.

Once you are satisfied that all these preparations have been completed successfully, programming can commence.

✂ First steps in programming a new model

Example: non-powered fixed-wing model aircraft

When **programming** a new model you should start by activating the ...

“select model” sub-menu (page 52)

... in the “Model memory” menu. Use the arrow buttons ▲ ▼ of the left or right-hand touch-key to select a free model memory ...



... then touch the central **SET** button of the right-hand touch-key. You are now immediately requested to select the type of model you wish to program.

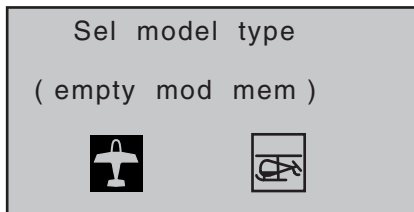

Since in this example we are setting up a fixed-wing model, we simply confirm the fixed-wing model symbol with a brief press on the central **SET** button of the right-hand touch-key; the screen now reverts to the basic display.

Notes:

- Naturally you can also use the pre-defined model memory 01 for programming your first model; this is the “fixed-wing model” type by default.
- Once you have called up the “Model select” option it

is not possible to interrupt the process, i.e. you must choose one or other model type. Even if you switch off the transmitter at this point, you cannot avoid this select procedure. However, if you make a mistake you can always correct it simply by erasing the model memory.

- If the battery voltage is too low, you will not be able to change model memories for safety reasons. The screen then displays an appropriate message:

not possible now
voltage too low

Now that you have overcome this first hurdle, you can start programming the actual transmitter settings to suit the model in the ...

“Basic settings” menu (pages 56 ... 62)

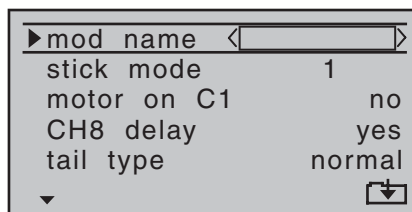

At this point you can enter the “Model name” by touching the central **SET** button of the right-hand touch-key in order to move to the character table:

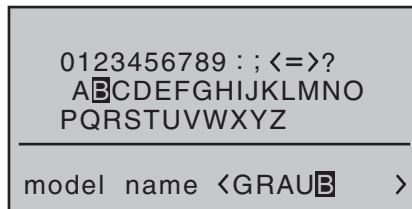

You should also check the settings for “Stick mode” and “Motor at Ch 1” and change them if necessary:

- “none”:
The brake system is “retracted” at the forward position of the throttle / brake stick; the “Ch8 delayed” option and the “Brake → NN *” mixers in the “Wing mixers” menu are activated.
The warning message “Throttle too high” - see page 28 - and the “Motor stop” option are disabled.
- “none/inv”:
The brake system is “retracted” at the back position of the throttle / brake stick; the “Ch8 delayed” option and the “Brake → NN *” mixers in the “Wing mixers” menu are activated.
The warning message “Throttle too high” - see page 28 - and the “Motor stop” option are disabled.
- “Throttle min. forward or rear”:
Ch 1 trim works forward or back. If the throttle stick is too far in the direction of “full-throttle” when you switch the transmitter on, you will be warned of this with the message “Throttle too high”.
The “Motor stop” option is activated, and the “Brake → NN *” mixers in the “Wing mixers” menu are disabled.

Note:

As mentioned previously, selecting “motor” or “no motor” also affects the range of mixers available in the “Fixed-wing mixers” menu. For this reason we shall initially consider “none” (no motor) in the following programming example.

In the next two lines you select the basic arrangement of the servos in the model, and inform the transmitter of

* NN = Nomen Nominandum (name to be stated)

your choice:

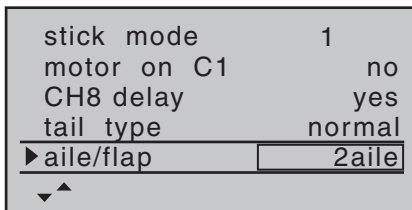

tail type: “normal”, “V-tail”, “delt/FIW” or “2elev sv”

aile/flap: 1 or 2 aileron servos and 0 or 2 flap servos

Note:

If your model is fitted with only one camber-changing flap servo, you should still select “... 2FL”. Later, in the “Fixed-wing mixers” menu (see page 88), you should select the “AIL → FL” mixer and set it to 0%. You can still exploit all the other mixers available at that point in the usual way.

At this juncture - if not before - you should check that the servos are connected to the receiver in the standard Graupner sequence:

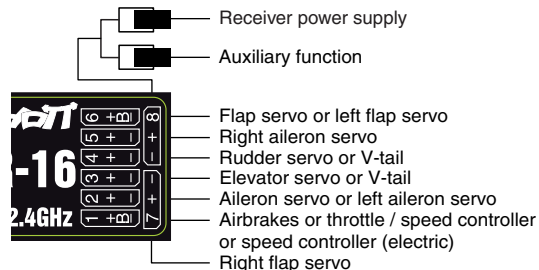

Notes:

- If you set up a V-tail, but the “up / down” and / or “left

/ right” functions work the wrong way round, please refer to the table in the right-hand column on page 44 for the remedy. The same procedure can be used if you set up flaperons (superimposed ailerons and flaps), and they work the wrong way round.

- The following settings apply to a model with a “normal” tail and no motor (“none”); if your model has a V-tail, the settings can be adopted virtually unchanged. However, if the model is a delta or flying wing, the situation is not quite so straightforward. A special programming example covering this model type will be found in the section starting on page 156.

In the ...

“Servo settings” menu (page 72)

▶ S1 =>	0%	100%	100%
S2 =>	0%	100%	100%
S3 =>	0%	100%	100%
S4 =>	0%	100%	100%
S5 =>	0%	100%	100%
▼ rev cent - trav +			

... you can set various parameters relating to the servos, i.e. “direction of rotation”, “neutral setting” and “servo travel”, to suit the requirements of the model.

By “requirements” we mean adjustments to servo centre and servo travel which are needed to compensate for minor tolerances in servos and slight inaccuracies on the model itself.

Note:

The facilities provided in this menu for setting asymmetrical servo travels are NOT intended as a means of setting up differential travel on ailerons and / or camber-changing flaps. There are more suitable options for

this in the form of specific functions in the “Fixed-wing mixers” menu; see the first two options in the picture on the right.

Once you have completed the settings described thus far, a fixed-wing or powered model aircraft (the latter if you enter the idle direction of the throttle stick in the “Motor at Ch 1” line of the “Basic settings” menu) will, in principle, fly.

However, there are no “refinements” in this set-up, and it is the refinements which will give you more long-term pleasure in your flying. Assuming that you are already capable of controlling your model safely, it's time to get a taste of these extra facilities; to this end we now move on to the ...

“Fixed-wing mixers” menu (pages 88 ... 93)

▶ diff aile.	0%	----
diff flaps	0%	----
ail->rudd	0%	----
ail->flaps	0%	----
brak->elev	0%	----
brak->flap	0%	----
brak->aile	0%	----
elev->flap	0%	----
elev->aile	0%	----
flap->elev	0%	----
flap->aile	0%	----
diff-red	0%	
▼		

Note:

This menu will show a varying range of options depending on the information you have entered in the “Basic settings” menu. In the illustration above, the full range is shown, as generated by the entries “2AIL 2FL” in the

“Ail/Flap” line, and “none (/inv) in the “Motor at Ch 1” line.

Of particular interest at the moment are “**AIL-Diff.**” (aileron differential) and the “**AIL → RUD**” (aileron → rudder) mixer, sometimes known as a combi-switch, and perhaps the mixers “**Brake → AIL**” and “**Brake → FLAP**”.

As already described in detail on pages 89 and 90, the purpose of “**AIL-Diff.**” (aileron differential) is to eliminate adverse yaw.

When a model aircraft turns, the down-going aileron produces more drag than the up-going one if both move through the same angle, and this causes the model to yaw in the opposite direction to the turn. This can be eliminated by setting differential aileron travel. A value between 20% and 40% is usually a good starting point, but the “perfect” setting nearly always has to be established by practical testing.

The same applies to the “**FL-Diff.**” (flap differential) option if your model also features two camber-changing flap servos, assuming that the flaps are also to be used as ailerons, e.g. using the “**AIL → FL**” mixer.

The “**AIL → RUD**” (aileron → rudder) mixer serves a similar purpose, but also makes many models generally easier to handle when turning. A value of around 50% is usually a practical starting point. However, it is advisable to be able to switch this function off, particularly if you have ambitions as an aerobatic pilot; this is done by assigning a physical switch to the mixer (for example, the writer switches this mixer off “automatically” when he switches into the “Speed” flight phase, simply by assigning the same switch to both options).

It is usually only necessary to set up a “**Brake → ELE**” (brake → elevator) mixer if your model suffers an excessive change of speed when you deploy the brak-

ing system. The danger is that you might need to retract the brakes again on the landing approach when you realise the model will “land short”; if its airspeed is too low when you retract the brakes, the model will just fall to the ground at that point. If you set up such a mixer it is important to test the setting at a safe height, and adjust the trim compensation if necessary.

If you have selected “2AIL” or “2AIL 2FL” in the “Aileron / Flap” line of the “**Basic settings**” menu ...

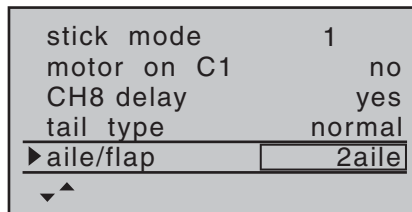

... and if you wish to be able to deflect both ailerons up using the throttle / brake stick (Ch 1), then a suitable value should be entered in the “**Brake → AIL**” line.

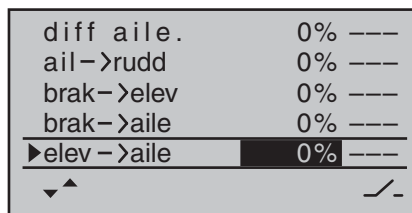

In principle the same applies to the “**Brake → FL**” line, which also becomes available if you have selected “2AIL 2FL”, although the set value should cause the flaps to deflect as far as possible in the downward direction when the brake stick is operated. It is important to ensure that the servos do not strike their mechanical end-stops. To achieve this, you may need to limit the servo travel(s) for the servos concerned using the “TRAVEL-

or “TRAVEL+” line on the “RX SERVO” display page of the “**Telemetry**” menu.

If the ailerons are set up to act as simple brakes, as described previously, or as part of the braking arrangement in a butterfly (crow) system, then you should *always* enter a value for “**Diff.-Red.**” (“differential reduction” - see page 93) - selecting 100% is the safe option here! Differential reduction means that aileron differential is suppressed proportionally *only* when you operate the airbrake stick. The purpose of this is to increase the down-going aileron travel on the landing approach, with the aim of improving *aileron response*.

If the wing is equipped with two camber-changing flap servos in addition to two separately actuated ailerons, then the “**AIL → FL**” (aileron → flap) mixer transfers the aileron movements to the flaps; we suggest that the flaps should not follow the movement of the ailerons to a greater extent than about 50%.

Note:

If you have only installed one flap servo, you should leave this mixer at 0%.

The “**FL → AIL**” (flap → aileron) mixer works in the opposite direction; depending on the layout of the model we suggest values between about 50% and 100% for this option. The flaps are controlled using the transmitter control or switch assigned to the input “E6”. Preferably, however, one of the rotary proportional controls (CTRL 6 ... 8) should be used for this.

Note:

*We strongly recommend that you reduce the travel of the flaps to about 25% in the “**Transmitter control settings**” menu, as this gives finer control of the flap positions using the selected transmitter control.*

The remaining options in the “**Fixed-wing mixers**” menu are designed to provide further fine-tuning of multi-flap wing systems, and are largely self-explanatory.

When you have completed the model-specific settings up to this point, you are probably ready to consider the model's first flight. At this juncture you should certainly take the time to carry out a series of “dry runs”, i.e. check all the settings thoroughly while the model is still on the ground. Remember that a serious programming error may damage more than just the model. If you are not sure of any point, please ask an experienced model pilot for advice.

If during the test phase you realise that one or other of the settings needs to be changed in order to tailor the model's control response to your preferences - perhaps the servo travels are too great or too small overall - then we suggest that you turn to the ...

“**D/R / Expo**” menu (page 82)

▶ aile	122%	+11%	2 ▢
elev	111%	+22%	2 ▢
rudd	100%	0%	---
▼ DUAL EXPO ↘			

... in order to adjust the overall set-up to suit your requirements and flying style.

The Dual Rate function is used to adjust the relationship between stick travel and control surface travel (see page 82). However, if it is only the model's control response around neutral which is too powerful for comfortable flying, i.e. the maximum travels are acceptable, then

“Exponential” can be employed, either instead of Dual Rates or in addition to them. If a physical switch is assigned to this function, you can switch between two Dual Rate / Expo settings while the model is flying.

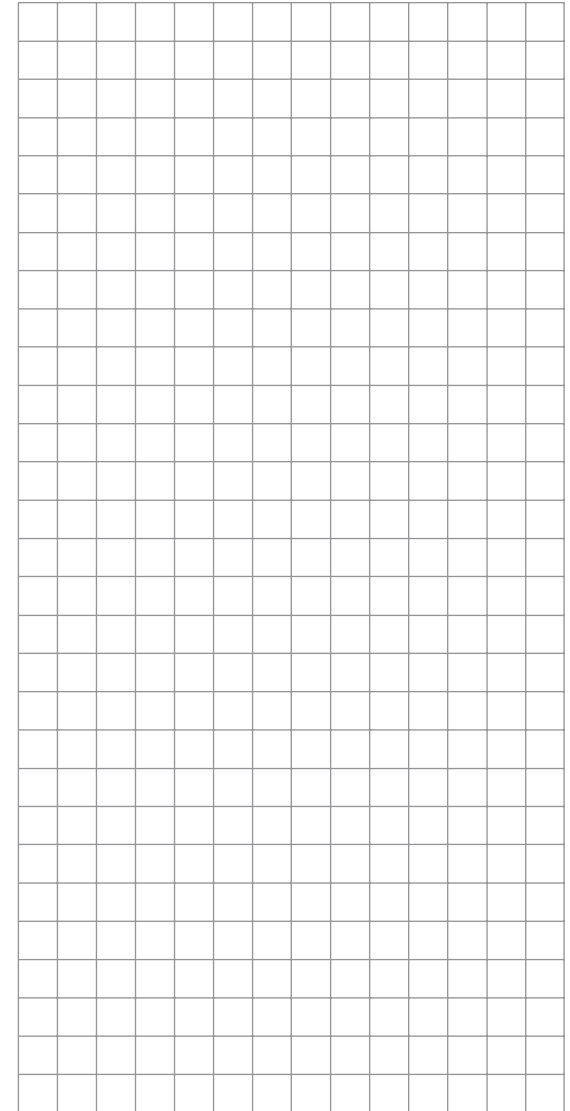

Including an electric power system when programming a model

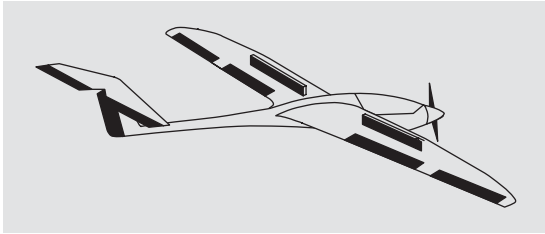

An electric power system can be controlled in various ways:

The simplest method of including such a power plant in a model program is to use the throttle / brake stick (Ch 1). However, in the preceding programming instructions we have already reserved the Ch 1 transmitter control for the airbrakes, which means that we have to explore other possibilities for controlling the motor: one is to use the switchable solution described in the section starting on page 150, and another is to use an alternative transmitter control. A suitable option is one of the two three-position switches SW 4/5 or 6/7, and another is one of the rotary proportional controls CTRL 6 ... 8. However, another alternative would be one of the two-position switches. The main reason for your choice ought to be that the switch is within easy reach of your fingers.

Before we turn to the individual examples, it is very important to note that the “transition delay” which occurs when you change flight phases also affects other switching processes which are triggered simultaneously, for example motor ON / OFF.

However, you may wish - especially in an emergency - to be able to switch the motor off instantly, i.e. without the transition delay. In this case it is advisable to make use of the “Ch8 delayed yes / no” option in the “**Basic settings**” menu. This is accomplished by connecting

148 **Programming example - fixed-wing model**

your speed controller to receiver output 8, moving to the ...

“**Basic settings**” menu, (pages 56 ... 62)

... and setting the “Ch8 delayed” option to “no”:

```

mod name < GRAUBELE >
stick mode          1
motor on C1         no
▶CH8 delay          no
tail type           normal
  
```

Example 1

Using one of the rotary proportional controls CTRL 6 ... 8

If one of these transmitter controls is used, the set-up is extremely easy. All you have to do is connect the speed controller to any of the receiver servo sockets 5 ... 8 which is vacant.

However, please bear in mind that outputs 2 + 5 and 6 + 7 may already be linked together, depending on the model type you have selected and the number of aileron and flap servos in your model.

Connect your speed controller to the next vacant input, and assign one of the rotary proportional controls CTRL 6 ... 8 - in our example CTRL 7 - to the selected input - for example, “E8”. This is accomplished in the ...

“**Transmitter control settings**” menu (page 74)

Use the arrow buttons ▲ ▼ of the left or right-hand touch-key to select the desired line. Touching the central **SET** button of the right-hand touch-key activates “Switch / transmitter control assignment”. Now turn the knob of

the rotary proportional control: after a brief delay the entry “Transmitter control 7” will appear in the highlighted field:

15	free	+100%	+100%
16	free	+100%	+100%
17	free	+100%	+100%
▶18	ctrl 7	+100%	+100%
▲ - trv +			

In the third column you can adjust servo travel to suit the speed controller you are using; alternatively you could use the “-Travel+” column in the ...

“**Servo settings**” menu (page 72).

S4	=>	0%	100%	100%
S5	=>	0%	100%	100%
S6	=>	0%	100%	100%
S7	=>	0%	100%	100%
▶S8	=>	0%	100%	100%
▲ rev cent - trav +				

The last stage is to check the settings, so move from the basic display to “Servo display”, typically by simultaneously touching the ◀ ▶ buttons of the left-hand touch-key: In the “OFF” position of the rotary control CTRL 7 the control channel you have selected - in this example channel “8” - should be at -100%, and at the “full-throttle” setting at +100%.

Example 2

Using a two-position switch, SW 2, 3 or 8

This variant implements a pure ON / OFF function, and results in the motor starting “abruptly” ... unless the speed controller you are using features what is known as a “soft start” function.

At the receiving end you need either a simple electronic switch or - if you want a smoother motor start - a suitable speed controller.

The settings for this arrangement are entered in the ...

“Transmitter control settings” menu (page 74)

First check which receiver socket (5 or higher) is available for connection to your speed controller. If you have assigned two aileron servos in the “Basic settings” menu, and if you have not connected any other auxiliary function, then this would be channel 6; if your model features two aileron servos and two flap servos, then channel 8 would be available for connecting the speed controller; the latter option is the one we wish to use in this example.

First set the selected switch to the “OFF” position, then use the arrow buttons ▲ ▼ of the left or right-hand touch-key to select the desired line in the menu. Touch the central **SET** button of the right-hand touch-key to activate “Switch / transmitter control assignment”, then move the selected switch from the “OFF” position to the “ON” position. The highlighted field now shows the switch number together with a symbol which indicates the direction of switching:

15	free	+100%	+100%
16	free	+100%	+100%
17	free	+100%	+100%
▶ 18	3	+100%	+100%
▲ - trv +			

In the third column you can adjust servo travel to suit the speed controller you are using; alternatively you could use the “Servo travel” column in the ...

“Servo settings” menu (page 72).

S4	=>	0%	100%	100%
S5	=>	0%	100%	100%
S6	=>	0%	100%	100%
S7	=>	0%	100%	100%
▶ S8	=>	0%	100%	100%
▲ rev cent - trav +				

The last stage is to check the settings, so move from the basic display to “Servo display” by simultaneously touching the ◀ ▶ buttons of the left-hand touch-key: in the switch’s “OFF” position, the control channel you have selected - in our example this is channel “8” - should be at -100%, and at the “full-throttle” setting at +100%.

Example 3

Using one of the three-position switches SW 4/5 or 6/7

This variant implements a three-stage solution for switching an electric motor on and off, and also results in an “abrupt” motor start-up ... unless the speed controller you are using features what is known as a “soft start” function.

At the receiving end you need a suitable speed controller.

First check which receiver socket (5 or higher) is available to connect your speed controller. If you have assigned two aileron servos in the “Basic settings” menu, and if you have not connected any other auxiliary function, then this would be channel 6; if your model features two aileron servos and two flap servos, then channel 8 would be available for connecting the speed controller; the latter option is the one we will use in this example. Move to the ...

“Transmitter control settings” menu (page 74)

... and use the arrow buttons ▲ ▼ of the left or right-hand touch-key to select the desired line. Briefly press the central **SET** button of the right-hand touch-key to activate “Switch / transmitter control assignment”. Move the selected three-position switch; the highlighted field now shows the number of this transmitter control, for example “Transmitter control 9”.

15	free	+100%	+100%
16	free	+100%	+100%
17	free	+100%	+100%
▶ 18	ctrl 9	+100%	+100%
▲ - trv +			

In the third column you can adjust servo travel to suit the speed controller you are using; alternatively you could use the “Servo travel” column in the ...

✈ Controlling the electric motor and butterfly (crow) system using the Ch 1 stick

“Servo settings” menu

(page 72).

S4	=>	0%	100%	100%
S5	=>	0%	100%	100%
S6	=>	0%	100%	100%
S7	=>	0%	100%	100%
▶S8	=>	0%	100%	100%
^ rev cent - trav +				

The last stage is to check the settings, so move from the basic display to “**Servo display**” by simultaneously touching the ◀ ▶ buttons of the left-hand touch-key: in the (upper) “OFF” position of the three-position switch the control channel you have selected - in our example this is channel “8” - should be at -100%. If you now move the switch toggle to the centre position, the bar should be in the middle, and at the (lower) “full-throttle” setting it should be at +100%.

Example 4

Butterfly / crow system as landing aid: ailerons up, flaps down

Before we start the programming of this fourth example, and turn our attention to expanding the basic programming we have already discussed, we need to consider briefly the position of the throttle / brake stick at “motor OFF” or “brake OFF”. Usually the Ch 1 stick is moved forward to open the throttle, and back to extend the brakes. However, if you adopt this “classic” configuration, and switch, say, from “motor OFF” (stick “back”) to the braking system, “full brake” would immediately be applied, and vice versa: if you switch from “brakes retracted” to power, this would instantly switch to “full power”.

It is certainly possible to make a “virtue” out of this “vice”: a “glider pilot” - usually flying with “brakes retracted = forward” will only switch to motor “ON” when necessary, and then reduce power to suit the situation (and - we hope - does not forget to move the Ch 1 stick back to the “forward” position when switching back). In contrast, a typical “power pilot” would probably operate with the reverse priority, i. e. he would only switch to “brake” when necessary, etc. In any case, it is possible to avoid these inter-connected effects by positioning the “zero point” of both systems so that they coincide. The above considerations mean that a “glider pilot” will probably prefer the “zero point forward” arrangement, while a “power pilot” might well decide on “zero point back”.

The **mx-16** HoTT transmitter can cope with whichever arrangement you prefer. However, the following section assumes that both “OFF” positions will be set to “forward”. If you prefer the alternative arrangement, there is no problem: the only difference compared with the ver-

sion described here is that you would select “none/inv” in the “Motor at Ch 1” line of the “**Basic settings**” menu instead of “none”. All the other settings can be adopted as described.

In the ...

“Transmitter control settings” menu (page 74)

mod name	< GRAUBELE >
stick mode	1
▶motor on C1	no
CH8 delay	yes
tail type	normal
▼▲	

... leave the “**motor at Ch 1**” line at “none” if you have set “Motor ON = forward”, or switch to “none/inv” if preferred. This is essential, otherwise the “**Brake 1 → NN ***” mixers which we need will be suppressed in the “**Fixed-wing mixers**” menu.

Important Note:

As it is essential to set the motor to “none”, this also automatically disables the “Throttle too high” power-on warning! For this reason please take great care to set the Ch 1 stick to the correct position before you switch the receiving system on.

The next step is to ensure that the speed controller connected to receiver output 1 is switched off “at the right end”. To accomplish this you may have to move to the ...

* NN = Nomen Nominandum (name to be stated)

“Servo settings” menu

(page 72)

▶S1	◀=	0%	100%	100%
S2	=>	0%	100%	100%
S3	=>	0%	100%	100%
S4	=>	0%	100%	100%
S5	=>	0%	100%	100%
▼ rev cent - trav +				

... and reverse the direction of servo 1.

For safety's sake you should check this setting now, before you continue with the programming procedure.

Take the transmitter and model to a location where it is safe to run the motor. Switch the transmitter on, and move the Ch 1 stick to the motor “OFF” position, i.e. either fully forward or back. Hold your model firmly, or ask a friend to hold it for you. Check that the propeller is free to rotate without causing havoc, then connect the flight battery and switch your model's receiving system on.

If the motor does NOT run when the stick is in the “forward” or “back” position (as appropriate), then everything is in order. However, please check the system anyway by gradually advancing the stick until the motor begins to run. When you are satisfied, stop the motor, then switch off the receiving system in the model and finally switch off the transmitter.

Note:

If the motor does not start, or spins in the wrong direction, this indicates that there are other problems which you must correct before you continue with programming. For example, check the wiring of your motor, and refer to the operating instructions supplied with your speed controller.

Once you are confident that the direction of the Ch 1 stick is “correct” as far as the motor is concerned, the next step is to ensure that you can switch its effect on the motor on and off, so that you can also control the braking system. This is carried out in the ...

“Free mixers” menu

(pages 107 ... 111)

▶M1		c1 → c1	2 =>
M2		?? → ??	=>
M3		?? → ??	=>
▼ typ fro to ↘ ↙			

... where you need to program a free mixer “c1 → c1”. When you have done this, use the arrow button ▶ of the left or right-hand touch-key to move to the column above the ↘_ symbol, and assign your selected “change-over switch” to this mixer; for example SW 2. This is done by activating the switch assignment by touching the central **SET** button of the right-hand touch-key, and moving the switch from “forward” to “back”, i.e. towards you.

With the mixer switched on, move to the column above the ▶ symbol using the arrow button ↙ of the left or right-hand touch-key, and then on to the second screen page by touching the central **SET** button of the right-hand touch-key.

At this point you should set an initial **SYM**metrical mixer value of -100%.

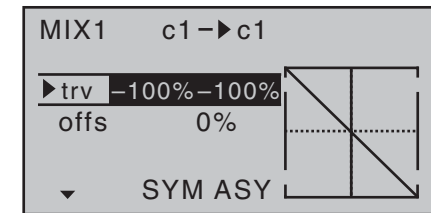

Now move to the “Offs” line: when you do this, the **SYM** and **ASY** fields are replaced by **STO** and **SET**. With the **STO** button highlighted, move the Ch 1 stick to the “OFF” position you have selected, and then touch the central **SET** button of the right-hand touch-key: the value to the right of “Offs” now changes from 0% to approx. +100%, and the graphic display of the mixer curve displayed on the right also changes accordingly:

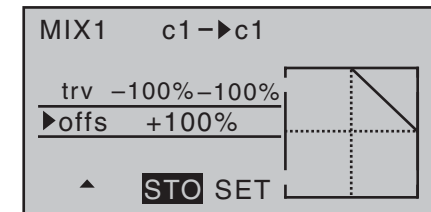

If you now touch the ◀ ▶ buttons of the left-hand touch-key simultaneously to move to the ...

“Servo display” menu

(page 113),

... you can immediately check the effect of the settings you have entered so far: with the mixer switched off, the bar display for Channel 1 follows the movement of the Ch 1 stick. With the mixer switched on it stops - as shown - at around -100%.

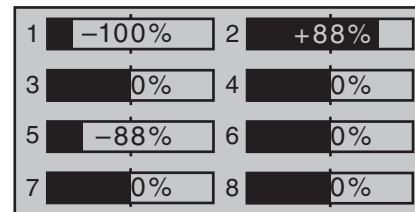
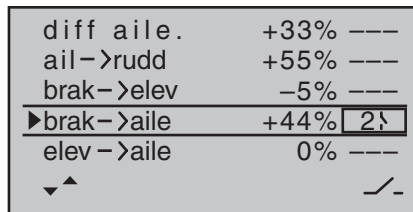

Note:

If you carry out this test with the receiving system and power system switched on, please take great care that you operate the change-over switch only in the “motor OFF” position! If you ignore this, there is a danger that the power system will be severely overloaded by being switched on abruptly, and it could even suffer damage. For the same reason you should be careful only to use the change-over switch at the “motor OFF” setting when you are flying the model.

To conclude the programming procedure, return the selected “change-over switch” to the “motor ON” position, i. e. “forward”; move back to the multi-function menu and from there to the ...

“Fixed-wing mixers” menu (pages 88 ... 93)

where - assuming that you have not already done this in your general model programming - you can select the “Brake → AIL” line and set the desired aileron travel when the Ch 1 stick is operated in the up direction (“Brake”). In the column above the ↘ symbol touch the central **SET** button of the right-hand touch-key before assigning your selected “change-over switch” by moving your preferred switch from “forward” to “back”.

Note:

The settings shown here are just examples, and must not be adopted under any circumstances without careful checking.

If your model also features camber-changing flaps, and you have therefore selected “2AIL 2FL” in the “Aile / flap” line of the “Basic settings” menu, locate the “change-over switch” you have just operated (in this case switch 2), move it “forward” again and switch to the “Brake → FL” line using the arrow buttons ▲ ▼ of the left or right-hand touch-key. You can now set the desired down-deflection of the flaps when the Ch 1 stick is moved (this flap position is termed “crow” or “butterfly”; see also page 92), and assign the external switch which also acts as the change-over switch by moving it from the “forward” to the “back” position, as already described.

If you now return to the “Servo display” menu and move the Ch 1 stick alone, you will see that the bar display for Channel 1 either remains at around -100% while the displays for channels 2 + 5 (and also the flaps 6 + 7, if set up) follow the stick movement, or the other way round: when the switch is operated, the latter stay at around the mid-point, and only the Channel 1 display moves.



Operating the timers using the Ch 1 stick or a switch SW 1 ... 9

If, following on from the model programming described on the preceding pages, you have decided on **Example 4** from the previous page, or you are using the Ch 1 stick (throttle / brake stick) to control motor power - independently of this programming example - then you can use the associated control switch to turn the stopwatch on and off automatically.

To assign this control switch, move the Ch 1 stick to the Idle position, then move to the “Timers” line in the ...

“Basic settings” menu (pages 56 ... 62)

Briefly touch the central **SET** button of the right-hand touch-key to activate the switch assignment, then select the input field above the switch symbol and move the throttle / brake stick from its idle position in the direction of “full throttle”. Depending on the direction of movement, the switch “G1” or “G2” will appear on the screen at a particular position of the Ch 1 stick:

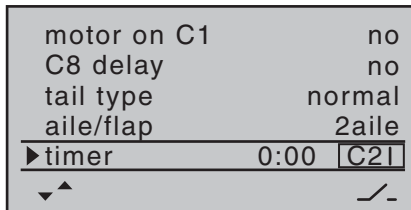

If you now move the stick back towards idle, you will see that the switch symbol changes again at around 80% of stick travel: between the “idle position” and the switching point the switch symbol is “open”, beyond this it is “closed” (see “Control switches” on page 39).

If you now repeatedly press the central **ESC** button of the left-hand touch-key to return to the transmitter's basic display, in order to check the system, you will see that the stopwatch and flight timer start running when

you move the stick past the switching point in the direction of full-throttle, and that the *stopwatch* alone halts again when you move the stick back to the idle position. When the stopwatch is halted, you can stop the flight timer by touching the central **ESC** button of the left-hand touch-key, and then reset both timers to their starting value by simultaneously touching the two arrow buttons ▲ ▼ of the right-hand touch-key (**CLEAR**) ... or re-start them by moving the stick beyond the switching point again.

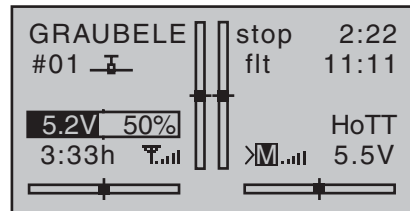

Tip:

When using an electric motor the motor run is usually limited by the capacity of the battery, and in this case you would normally set the stopwatch to “count down”. Simply enter the maximum permitted motor run, e.g. “5 min.”. As described on pages 59 and 67 ... 68, the transmitter's sounder starts to emit warning tones “30 sec” before “zero”.

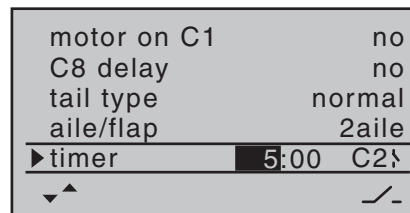

With the stopwatch halted, touch the central **ESC** button

of the left-hand touch-key (**CLEAR**) button in the basic display, so that the stopwatch switches to the “Timer” function. The timer can now be started and stopped using the throttle control.

Alternatively, if you control your motor using one of the switches SW 1 ... 4 or 6/7, as described in **Examples 2** or **3**, you do not need any of the previously described control switches. All you need to do is locate the switch which you use to turn your motor on and off, and assign the same switch to the “Timers”, with the same switching direction, so that they start running at the same moment you turn the motor on.

In contrast, if you have decided on the solution described in **Example 1**, then unfortunately there is no alternative but to operate the motor and timers separately.

✂ Using flight phases

Within any of the twenty model memories you can program up to four different flight phases (states of flight), each incorporating settings which can be entirely different from the others.

Each flight phase can be called up by means of a switch. Flight phases represent the simplest and most convenient method of switching between different model settings in flight, and are programmed for different stages of a typical flight, such as “normal”, “thermal”, “speed”, “distance” etc.

We assume that you have already programmed the model in the transmitter’s model memory, set it up carefully, test-flown it and trimmed it out properly. First move to the ...

“Basic settings” menu (pages 56 ... 62)

aile/flap	2ail2fl
timer	5:00 2↓
phase 2	takeoff ---
phase 3	speed ---
▶ phase 4	landing ---
▼▲	↖/↗

... and then to the line “Phase 2”, “Phase 3” and / or “Phase 4”, where you can either accept the default name or assign a specific, more appropriate, name to each flight phase. The purpose of this name is just to help you differentiate between the flight phases; it has no significance in terms of programming. It will later appear in the transmitter’s basic screen display, and also in the “Phase trim” and “D/R Expo” menu.

A physical switch must be assigned so that you can select the different flight phases. The ideal one for switching a maximum of three flight phases is one of the

three-position switches SW 4/5 or 6/7, located at front left and right on the transmitter.

Each of the two end-points of this switch should be assigned to one flight phase, *starting from the centre position*. We recommend that the switch direction should match the phase numbering: as shown in the left-hand illustration, for example, “Phase 2” is “forward” from the centre position, while “Phase 3” is “back” (towards you). Select the appropriate line, name, and switch assignment in the “usual” way, i.e. using the various touch-keys.

aile/flap	2ail2fl
timer	5:00 2↓
phase 2	takeoff 4↓
phase 3	speed ---
▶ phase 4	landing 5↓
▼▲	↖/↗

Note:

In principle it makes no difference which names you assign to the various phases - with the exception of Phase 1, which is assigned the name “normal”, and is always active when flight phases 2, 3 and 4 are disabled.

For general model flying three flight phases are usually quite sufficient:

- “Launch” or “Thermal” for launch and “staying up”,
- “Normal” for normal conditions, and
- “Speed” for flying in “top gear”.

At this point all three phases have been set up and assigned names, and you can switch between them; however ... if you operate the phase switch you will soon notice that nothing has changed, i.e. all the settings for the control surfaces, and especially the wing flaps, are

the same.

To change these settings, call up the ...

“Phase trim” menu (page 86)

... move the phase switch (or switches) to the appropriate position, and enter the desired values in the standard way by touching the input buttons, in a similar way to the method of adjusting transmitter control centres and offsets with other radio control systems.

P H A S E T R I M			
normal	0%	0%	0%
takeoff	+8%	4%	+2%
speed	-7%	-5%	-3%
*thermal	+10%	+5%	+2%
	FLA	AIL	ELE

If you now switch the receiving system on and select the different phases in turn, you will see a difference in control surface response. The differences are also reflected in the bar display for the servos in the “Servo display” menu, which you can call up from virtually any menu position by simultaneously touching the ◀ ▶ buttons of the left-hand touch-key.

Note:

Depending on the information you have entered in the “aile/flap” line of the “Basic settings” menu, the “ELE” column alone, the “AIL” and “ELE” columns, or - as shown above - “FLAP”, “AIL” and “ELE” may appear on the screen for “Phase trimming”.

Programming example: servos running in parallel

In some cases a second servo is required to run in parallel with an existing servo; for example, if a second elevator or rudder is to be actuated by a separate servo, or where a second servo is needed to cope with very high control forces, or where two servos are required for a large control surface due to the high forces involved. This task could be solved simply by connecting both servos together in the model using a conventional Y-lead. However, this has the drawback that the linked servos cannot be adjusted individually from the transmitter, i.e. you forfeit the basic advantage of the computer radio control system: separate adjustment of individual servos from the transmitter.

Another option would be to call up the Telemetry menu and use its “Channel mapping” option instead of a simple Y-lead; see page 121. However, the simplest method is to use the transmitter’s software facilities. For example, it is easy to set up ...

Two elevator servos

... to operate in parallel. First move to the ...

“Basic settings” menu (page 56 ... 62)

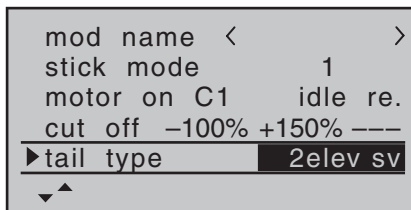

... and set “2elev sv” in the “tail type” line.

The two elevator servos are then connected to receiver output sockets 3 and 8.

Two rudder servos

In this example we will connect two rudders “in parallel” using the “Free mixers” menu. The second rudder could be connected to receiver output 8, which is not already in use.

The first step is to move to the ...

“Free mixers” menu (pages 107 ... 111)

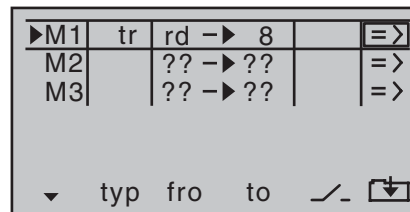

... and set up a mixer “Tr RUD → 8”.

In the “Type” column select the “Tr” setting, so that the rudder trim affects both rudder servos.

Finally switch to the graphics page and set a **SYM**metrical mixer input of +100%:

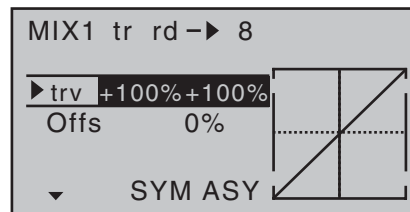

Once again, for safety reasons it is really essential that you set input 8 to “free” in the “Transmitter control settings” menu.

As an added refinement, you may want both rudders to deflect outwards only, as part of a braking system controlled by the Ch 1 stick. This can be accomplished by setting up two additional mixers “c1 → 4” and “c1 →

second rudder control channel”, with suitable servo travel settings. An offset of +100% is then selected for both mixers, as the Ch 1 stick is (usually) at its top end-point when the airbrakes are retracted, and the winglet rudders are only required to deflect outwards proportionally when the brakes are extended.

Programming example: Delta / flying wing

On page 142, where the section on fixed-wing model programming starts, you will find general notes regarding the installation and set-up of the RC system in a model, and - of course - this applies equally to deltas and flying wings. The information on test-flying and refining the settings is also relevant, including the section on programming flight phases.

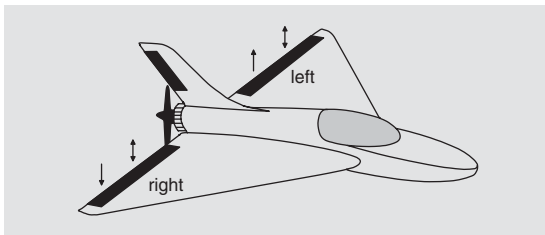

In their characteristic shape and geometry, deltas and flying wings differ very significantly from “normal” models even at first sight, but the differences in the requisite servo arrangement are rather more subtle. The “classic” model delta or flying wing generally has only two control surfaces, which act both as ailerons (in opposite directions) and as elevators (in the same direction), in a similar way to the superimposed rudder / elevator functions of a V-tail. More modern designs tend to be more complex; one (or two) inboard control surfaces may be used purely as elevators, while the outboard ailerons also act as elevators, but to a reduced extent. If a flying wing has four or even six wing control surfaces, it is certainly feasible nowadays to set them up with camber-changing flap functions and / or even a butterfly (crow) system.

However, most of these models still rank as “classic” deltas and flying wings, and for them the servos should be connected to the receiver as follows (see also page 44):

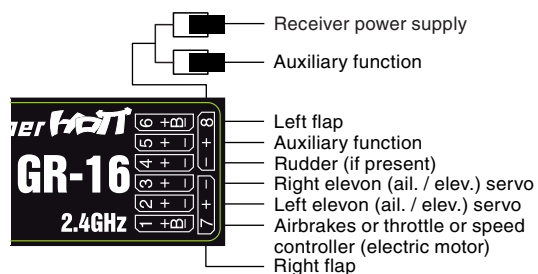

If your delta or flying wing is of more “modern” configuration, the “normal” servo sequence has proved useful; this arrangement can also be used for canards:

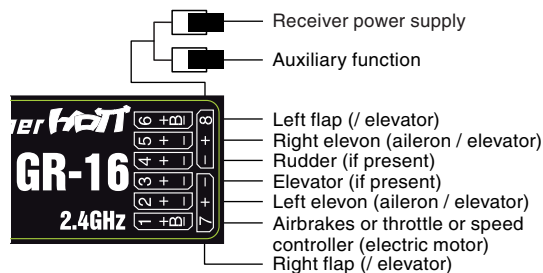

Depending on the receiver servo sequence you select, you should first move to the ...

“Basic settings” menu (pages 56 ... 62)

... and select the following options in each line:

“motor at C1”: • “none”:

The brake system is “retracted” at the “forward” position of the throttle / brake stick; the “Ch8 delayed” option and the “Brake → NN **” mixers in the “Wing mixers” menu are *activated*.

The warning message “Throttle too

high” (see page 28) and the “Motor stop” option are *disabled*.

- “none/inv”:

The brake system is “retracted” at the “back” position of the throttle / brake stick; the “Ch8 delayed” option and the “Brake → NN **” mixers in the “Wing mixers” menu are *activated*.

The warning message “Throttle too high” (see page 28) and the “Motor stop” option are *disabled*.

- “Idle forward” or “Idle rear”

The Ch 1 trim operates either forward or back. If you switch the transmitter on with the throttle stick too far in the direction of full-throttle, you will see the warning message “Throttle too high” on the screen.

The “Motor stop” option is *activated*, and the “Brake → NN **” mixers in the “Wing mixers” menu are *disabled*.

“tail type”: “Delta / flying wing” or “Normal”

“aile/flap”: Two ailerons “2ail” and - if present - two flaps “2fl”.

The primary function of these settings is to define the range of wing mixers which the software makes available. If you select the “Delta / flying wing” tail type, the software automatically superimposes the elevator and aileron functions. In this case the mixer ratios can be adjusted by varying the Dual Rate settings in the “D/R /

* NN = Nomen Nominandum (name to be stated)

Expo” menu (see page 82).

If you select **“Delta / flying wing”**, all settings of the **“NN * → elev”** wing mixers in the ...

“Fixed-wing mixers” menu (pages 88 ... 93)

diff aile.	0%	----
ail → rudd	0%	----
▶ brak → elev	0%	----
diff-red	0%	

... affect the elevator (up / down) function of the two elevon (combined aileron / elevator) servos, as well as the flap / elevator servos.

Notes:

- The flap mixers and flap differential only appear in the list if you have also entered “2fl” in the “aile/flap” line at the “Delta / Flying wing” model type; see illustration on the right.
- In principle the same applies to the “Brake → NN **” mixers. These are also suppressed if you have decided on “Throttle min forward / back” in the “motor on C1” line of the **“Basic settings”** menu.
- Even if you have selected “2aile2fl”, the (digital) elevator and aileron trims only affect aileron / elevator. If you wish to circumvent this, it is simpler to program your model as described in the following section.

* NN = Nomen Nominandum (name to be stated)

Programming a model delta using the “normal” tail setting

Alternatively, if you select the **“normal”** tail type in the **“Basic settings”** menu, and connect the servos to the receiver as shown in the lower of the two receiver socket sequence diagrams on the left-hand page, then the aileron function of the two elevon servos will work correctly, but not the elevator function.

In the **“normal”** tail type you have to force the two aileron servos and the two flap servos to move in the same direction and provide an elevator effect when an elevator command is given. This requires the **“elev → NN **”** wing mixers, whose effect can be adjusted separately. The procedure starts by selecting the ...

“Fixed-wing mixers” menu (pages 88 ... 93)

(The following settings are model-specific, and you must check carefully that they work correctly on your model before accepting them.)

diff aile.	0%	----
diff flaps	0%	----
ail → rudd	0%	----
ail → flaps	+55%	----
brak → elev	0%	----
brak → flap	+55%	----
brak → aile	+66%	----
elev → flap	+77%	----
▶ elev → aile	+77%	----
flap → elev	0%	----
flap → aile	0%	----
diff-red	0%	

... where you set values other than zero for these mixers. With this set-up the tailless model is considered to be a

“normal” four-flap wing (two ailerons and two flaps), and therefore has all the options associated with this wing type. The method involves the **“elev → NN **”** mixers, which were originally intended only for pitch trim compensation and non-standard applications. In this case they are “abused” by setting higher values than normal, in order to transfer the elevator signal to the control surfaces of the tailless model.

However, none of the fixed-wing mixers includes the digital trim of the elevator stick - so an alternative has to be found.

Start by switching to the ...

“Transmitter control settings” menu (page 74)

15	ctrl 6	+15%	+15%
▶ 16	ctrl 6	+15%	+15%
17	free	+100%	+100%
18	free	+100%	+100%

... and assign the *same* transmitter control to the inputs 5 and (if required) 6, e.g. the rotary proportional control CTRL 6. Now move to the “Travel” column and reduce the travel of the transmitter control for these two inputs symmetrically to around 50%, or even less, because: the lower this value, the finer the trim control.

However, if you prefer to use the normal elevator trim lever, set - or leave - the **“elev → NN **”** mixers to 0%, and instead set up free linear mixers to do the job.

This is done by calling up the ...

“Free mixers” menu (pages 107 ... 111)

M1	tr	el →	5	=>
▶M2	tr	el →	6	=>
M3		?? →	??	=>

▼ ▲ typ fro to ↗ ↘

... and setting up one linear mixer “Tr elev → 5”, and - if necessary - “Tr elev → 6”.

Move to the graphic page of this menu to set the required mixer ratios. Check the settings, and above all the direction of effect, in the “**Servo display**”, or on the model itself, and change the prefixes if necessary.

If you carry out the programming as described above, the ailerons will also move in the same direction, like flaps, when you move the elevator stick. The effect of the “tr” option is that the elevator trim lever also affects the associated mixer when you operate the elevator stick.

Since an additional transmitter control is no longer required for this arrangement, you should disable input 5 and (if used) input 6 in the second column of the “**Transmitter control settings**” menu; simply set these inputs to “free”.

Many years ago, the author flew a model delta programmed exactly in this way using the **mc-20**, with the following additional refinements: “flap settings” used as trim, and butterfly (crow) as landing aid - the latter exploiting the “Brake → ALL” and “Brake → FL” wing mixers to provide complete compensation for pitch trim changes in both directions. In this case the term “ailerons” means the outboard wing control surfaces, and “flaps” the inboard pair of control surfaces.

A modern sweptback flying wing can be controlled in

a similar fashion. These models also feature inboard and outboard control surfaces: the former forward of the Centre of Gravity, the latter aft of it. Deflecting the inboard control surface(s) *down* increases lift and produces an *up-elevator effect*; deflecting them up creates the opposite effect. In contrast, the outboard ailerons act in the reverse direction: a *down*-deflection produces a *down-elevator effect*, and vice versa. There are really no limits to what can be achieved with appropriate settings of the system’s sophisticated mixers.

However, please note that you should be extremely careful when setting differential travel with such a configuration, regardless of your model’s set-up, its tail type and the number of servos you are using. This is because differential travels on a tailless model tend to produce an asymmetrical elevator effect, rather than the desired adverse yaw reduction. For this reason it is advisable to start with a differential setting of 0% - at least for the first few flights. When you are familiar with the model and feel the need to experiment, it may then be feasible under certain circumstances to try differential settings deviating from zero.

For larger models it could be advisable to install winglets fitted with rudders, i.e. small vertical surfaces at the wingtips. If these are actuated by two separate servos, they can be controlled as described in the example on page 155 dealing with “Servos running in parallel”, or using “Channel mapping” in the “**Telemetry**” menu; see page 121.

You may also want both rudders to deflect outwards when a braking system is operated using the Ch 1 stick, and this can be accomplished as follows: if you have selected the “**normal**” tail type, set up two further mixers “**c1 → 4**” and “**c1 → second rudder control channel**”

with suitable travel settings. The offset for both mixers should be +100%, as the Ch 1 stick is usually at the forward end-point when the airbrakes are retracted, and the winglet rudders are only required to deflect outwards proportionally when the brakes are extended.

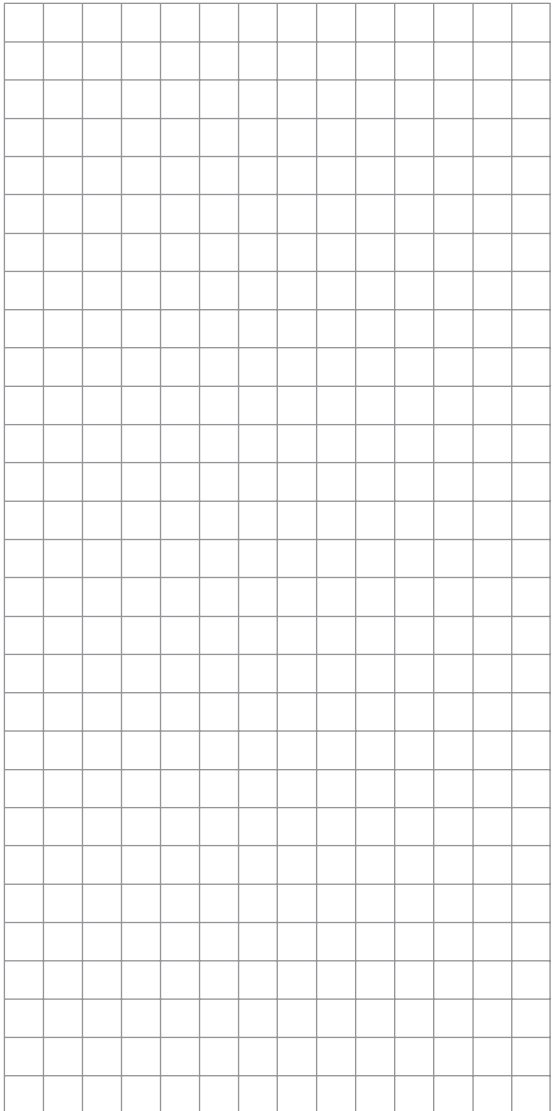
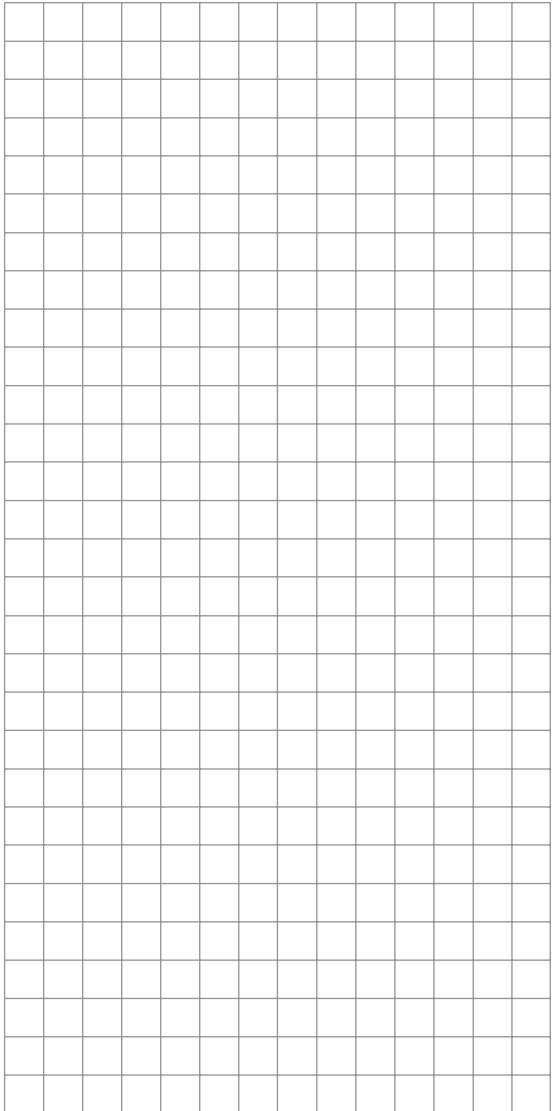
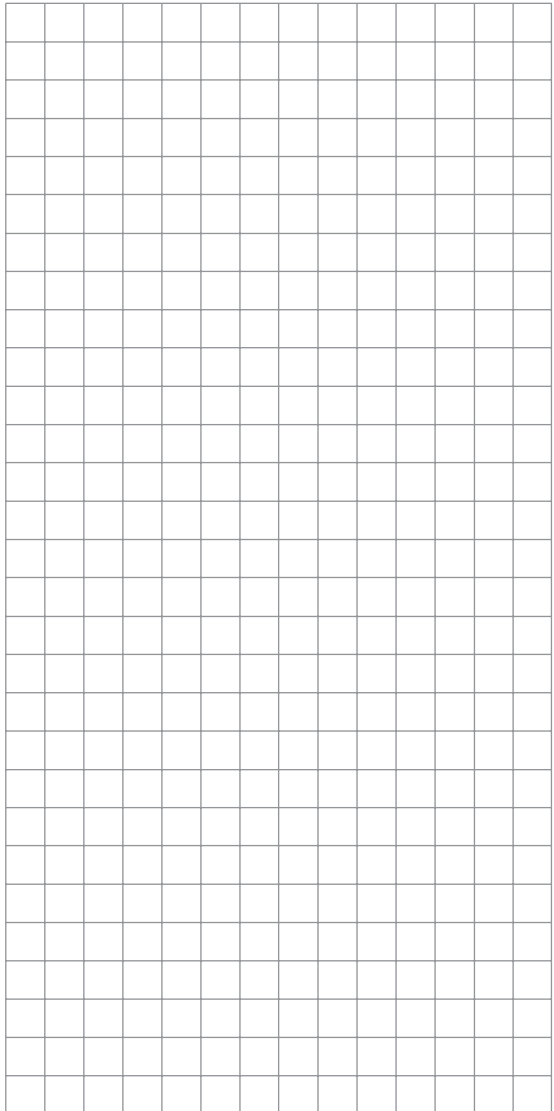

Programming example: F3A model aircraft

F3A models belong to the category of powered fixed-wing model aircraft designed for competition flying. They may be powered by an internal combustion engine or an electric motor. Electric-powered models are eligible and totally competitive in the international F3A “pattern” class, and also in the F5A electric aerobatic class.

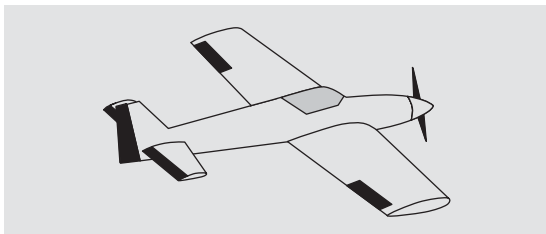

In this programming example we assume that you have already read through the description of the individual menus, and are therefore familiar with the general method of handling the transmitter.

On page 142, where the section on fixed-wing model programming starts, you will find general notes on installing and setting up the RC system in a model, and - of course - this applies equally to F3A models, and therefore does not need to be repeated at this point.

If an F3A model is accurately built, it usually exhibits flying characteristics which are almost completely neutral. The perfect aerobatic model has a very smooth but precise control response, and any movement around any one of its flight axes should not affect the other axes.

F3A models are flown using aileron, elevator and rudder controls. The use of separate servos for each aileron is almost universal. The flying controls are supplemented by control of motor power (throttle function) and in many cases a retractable undercarriage. As a result the servo assignment for channels 1 to 5 is no different from the

fixed-wing models we have already described.

The auxiliary function “Retracts” is usually assigned to one of the auxiliary channels 6 to 8. Ideally the retracts are operated using one of the two switches without a centre detent (SW 3 or SW 8). An optional “extra” - used only if necessary - is mixture adjustment control for the carburettor. This is generally operated by one of the rotary proportional controls CTRL 6 ... 8, connected to one of the auxiliary channels not already in use.

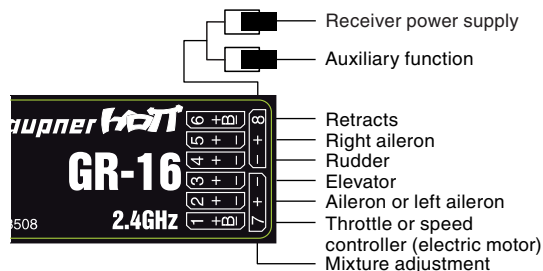

When assigning functions to the auxiliary channels at the transmitter, it is advisable to ensure that the controls required are within easy reach, since the advanced aerobatic pilot has very little time to think about letting go of the sticks - especially when flying under competition conditions.

Programming

The basic programming of the transmitter has already been described in detail in the section starting on page 144, so this section concentrates on tips specific to F3A models.

In the ...

“**Servo settings**” menu (page 72)

▶S1	=>	0%	100%	100%
S2	=>	0%	100%	100%
S3	=>	0%	100%	100%
S4	=>	0%	100%	100%
S5	=>	0%	100%	100%
▼	rev cent	-	trav	+

... you can adjust the servo settings to suit your model.

It has proved advisable to use at least 100% servo travel, as precision of control can be perceptibly better if relatively large servo travels are employed. This should be borne in mind when building the model and designing the control surface linkages. Any minor corrections required can be made in the third column during the initial test flights.

The next step is to select the ...

“**Basic model settings**” menu (page 56 ... 62)

... and activate the idle trim for Channel 1 (normally “Idle back”; i.e. full-throttle forward). The digital trim now works at the idle end of stick travel. The “cut-off trim” enables you to switch immediately from the “motor stopped” position to the idle position you have previously established just by applying a single “click” on the trim lever (see page 40).

stick mode	1
▶ motor on C1	idle re.
cut off	-100% +150% 9\
tail type	normal
ail/flap	2aile
▼▲	

The remaining settings should be adjusted as required to suit your personal preferences.

You may find it necessary to assign transmitter controls to particular inputs to operate the retractable undercarriage and carburettor mixture adjustment. This is carried out in the ...

“Transmitter control settings” menu (page 74).

For example, you may like to assign a particular transmitter control - perhaps one of the ON / OFF switches SW 2 or 8 - to the input “E8” for the retracts, and a rotary proportional control - e.g. CTRL 6 - to the input “E7”, for mixture adjustment.

15	free	+100%	+100%
16	free	+100%	+100%
▶ 17	ctrl 6	+100%	+100%
18	8	+100%	+100%
▼▲		- trv	+

The retracts are extended and retracted when you operate the switch “SW 8”. You may need to adjust the travel of the transmitter control, and perhaps reverse that channel by setting a negative prefix for servo travel.

F3A models fly fairly fast, and respond very “solidly” to corrective movements of the servos. However, in competition flying it is vital that all abrupt control movements

and corrections should be kept to a minimum, as the judges will invariably notice any lack of smoothness and dock a few points, so it is advisable to set exponential control characteristics on the stick functions.

Move to the ...

“D/R Expo” menu (page 82).

Exponential values of around +30% on aileron, elevator and rudder have proved to be a good starting point, and you can set them in the right-hand column of this menu. These values provide smooth, well-defined control of the typical F3A model. Many experts use higher values; even up to +60% exponential.

ail	100%	+33%	---
elev	100%	+33%	---
▶ rudd	100%	+33%	---
▲	DUAL EXPO		↘

Since F3A models generally have two aileron servos, it has proved useful to deflect both ailerons “up” *slightly* for the landing. In most cases this causes the model to fly a little more slowly and with a more stable attitude on the landing approach.

To achieve this you will need to program mixers in the ...

“Free mixers” menu (section starting on page 106).

Both ailerons are usually required to deflect “up” as a landing aid, in parallel with the movement of the throttle stick, but only from the half-throttle setting in the direction of idle. From that point on, the further the stick is moved towards the idle position, the more the ailerons deflect up. The reverse occurs when you open the throttle: the ailerons are returned to neutral to avoid the

model suddenly ballooning up.

A little down-elevator must usually be mixed in to ensure that the aeroplane does not climb when the ailerons / flaps are deployed.

To meet these requirements you need the two mixers shown in the illustration below.

M1	c1 -▶ 5	3l =>
▶ M2	c1 -▶ el	3l =>
M3	?? -▶ ??	=>
▼▲	typ fro to	↘

The mixers are activated using one and the same external switch, e.g. “SW 3”, which therefore has to be assigned to *both* mixers, with the same direction of effect. Touch the central **SET** button of the right-hand touch-key to move to the mixer inputs on the second screen page, and set the appropriate mixer ratios. In both cases the mixer neutral point should be left at the centre position of the Ch 1 stick travel.

For this reason you should now move the Ch 1 stick to the Idle range, select the **ASY** field, and enter the following values:

MIX 1: -60% ... -80% and

MIX 2: -5% ... -10%.

Example of MIX 1:

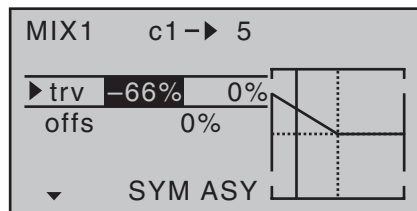

This completes the basic set-up for a typical F3A model.

Correcting model-specific errors

It is an unfortunate fact of life that even very carefully built models exhibit minute faults and inaccuracies which produce unwanted deviations when the model is flying; the mixers of a computer radio control system are then needed to compensate for these deficiencies. In this section we will describe how to carry out the adjustments required, but please note the following points before we get started: it is vital to ensure that the model is built as *accurately as humanly possible*, is balanced perfectly around the lateral and longitudinal axes, and that motor downthrust and sidethrust are set correctly.

1. Rudder causes unwanted movement around the longitudinal and lateral axes

It is often the case that a rudder command causes the model to rotate slightly around the longitudinal and / or lateral axis. This is particularly troublesome in what is known as knife-edge flight, where the model's total lift is generated by the fuselage, aided by the rudder deflection. The result is that the model rotates and changes heading slightly, as if the pilot were applying aileron or elevator at the same time. These tendencies have to be corrected with compensation around the lateral axis (elevator) and around

the longitudinal axis (aileron).

These corrections can be achieved easily with the **mx-16** HoTT, exploiting the “free mixers” once again. For example, if the model rotates to the right around the longitudinal (roll) axis when the rudder is deflected to the right for a knife-edge pass, then a mixer is set up which deflects the ailerons slightly to the left. Heading changes around the lateral (elevator) axis can be corrected in a similar way using a mixer acting upon the elevator:

- Correction around the lateral axis (elevator)
MIX “rd → el”
ASYmmetrical setting. The exact values required must be found by flight testing.
- Correction around the longitudinal axis (aileron)
MIX “rd → al”
ASYmmetrical setting. The exact values required must be found by flight testing.

In most cases relatively small mixer values are called for - typically below 10% - but this does vary from model to model.

2. Vertical climb and descent

Many models exhibit a tendency to deviate from the ideal line in vertical climbs and descents. To correct this we need an elevator neutral position which varies according to the throttle setting. For example, if the model tends to pull out of a vertical descent by itself when the motor is throttled back, slight down-elevator must be mixed in at this throttle setting.

MIX “c1 → el”

As a rule you will need to set mixer values below 5%, but once again there is no substitute for test-flying.

3. Rolling (movement around the longitudinal axis) at idle

When you reduce the throttle setting, the model may tend to roll slightly in one direction. Clearly an aileron correction must be made. However, it is much more elegant to let a mixer correct this effect for you than to move the stick manually. Once again, a mixer needs to be set up:

MIX “c1 → al”

As a rule you will need to set mixer values below 5%, but once again test-flying is called for.

The adjustment process should only be carried out in calm weather. Often all you need to do is apply the mixer in the control segment between half-throttle and idle. To achieve this, leave the Offset point at the centre position, and set up the mixer **ASY**mmetrically.

4. Rolling when ailerons and flaps are extended

If you fly the landing approach with both ailerons deflected up, the model may show a tendency to roll slightly due to minor variations in aileron servo travel (or constructional inaccuracies); i.e. the model may turn to either side by itself. Once again, this tendency can easily be corrected using a mixer to vary the compensation according to the position of the ailerons / landing flaps.

MIX “c1 → al”

It is essential to provide a means of switching the mixer on and off using the switch which controls the aileron / landing flap function (see previous page), to ensure that this mixer only has any effect when the aileron / landing flap function is activated. The optimum value has to be found by test-flying.

And finally a few words on the ...

“FAIL-SAFE settings”

We strongly recommend that you make use of the safety potential of this option by at least setting the throttle position (glow-powered models) to idle, or the electric motor to stop, if a fail-safe event should be triggered. This simple precaution ensures that the model is much less likely to create havoc and cause property damage or personal injury. If you also program the fail-safe positions of the control surfaces in such a way that the model flies steadily descending circles in case of interference, then you have a good chance that it will land relatively gently even if the radio link fails for a protracted period. This also gives you plenty of time to restore the connection, should the whole 2.4 GHz frequency band suffer interference for a while.

In the receiver’s default state, however, the servos remain in their last valid position (“hold mode”) when interference occurs. You can program any individual servo output of your receiver to a “fail-safe position” (fail-safe mode), as described on page 116.

Summary

The settings described on this page are intended primarily for the expert flyer. Please bear in mind that refining the flying characteristics of a model aeroplane to this extent involves tremendous effort, time, sensitivity and expertise. Some experts continue the programming procedure even when they are flying, although it is not advisable to try this if you are just a moderately advanced pilot making your first attempt with an F3A aerobatic model. You would be well advised to request help from an experienced pilot, and carry out the fine-tuning adjustments mentioned here one by one, with the expert at your side, until your model exhibits the neutral flying characteristics you desire.

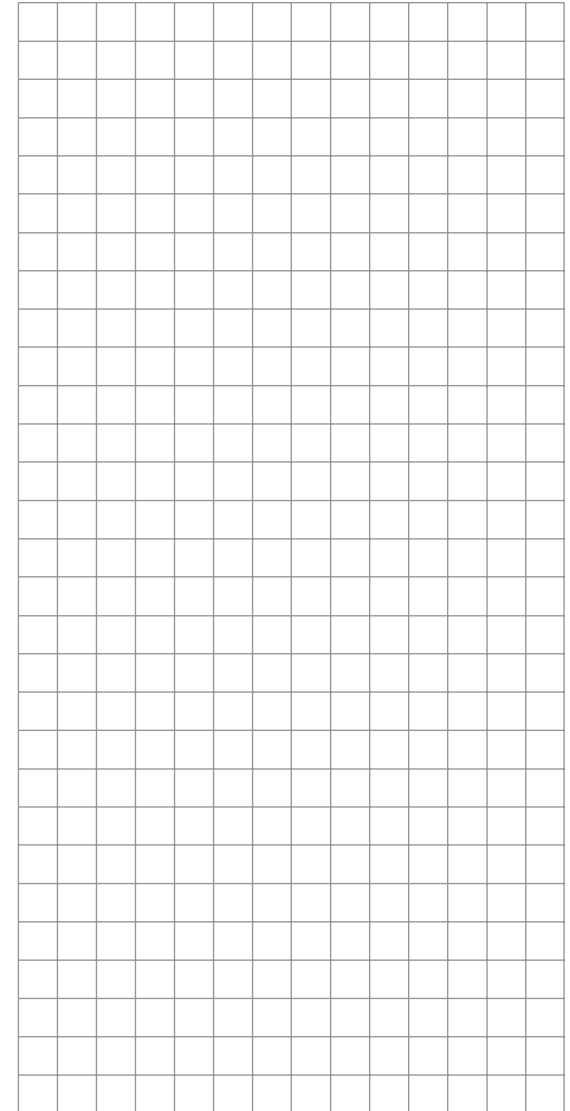

Programming example: model helicopter

In this programming example we assume that you have already read and understood the descriptions of the individual menus, and are by now familiar with the general handling of the transmitter. We also assume that you have assembled and adjusted the helicopter exactly according to the kit instructions. The electronic facilities provided by the transmitter should never be used to compensate for major mechanical inaccuracies.

As so often in life, there are various ways and means of reaching a particular destination when programming the **mx-16** HoTT. In this example our intention is to provide a sensibly structured course of action, so that you have a clear idea of logical programming techniques. Where there are several possible methods, we first describe the simplest and most easily understood solution. It is likely that the helicopter will work perfectly when set up in this way, but naturally you are still free to try out other solutions at a later stage, in case they suit you better.



As our programming example we take the *Graupner* STARLET 50 helicopter, with right-hand rotation, three swashplate linkage points distributed evenly at 120° (“3Sv (2 roll)” type), a beginner’s set-up without enhanced throttle curve, without heading-lock gyro system, no method of influencing the gyro’s “normal operating mode” from the transmitter, and with no speed governor (regulator).

We have deliberately chosen this simple programming project in order to demonstrate that it is possible to set up a helicopter which flies extremely well with relatively little programming effort.

Nevertheless, we do not want to forfeit all the possible refinement facilities: after the basic description you will also find set-up notes on gyro gain, speed governors and flight phase programming.

Note:

If, in contrast to the glow-powered machine described here, your main interest lies in electric-powered model helicopters, then please read on! Apart from the idle adjustments, which naturally do not apply, you can adopt most of the settings described in the following section virtually unchanged.

To initiate this typical programming exercise move to the “**Model memory**” menu, then to the ...

“**select model**” sub-menu (page 52),

... where you select a free model memory using the arrow buttons of the left or right-hand touch-key:

01		R08
02	**free**	
03	**free**	
04	**free**	
05	**free**	
06	**free**	

After touching the central **SET** button of the right-hand touch-key, you can use the  button of the left or right-hand touch-key to select ...

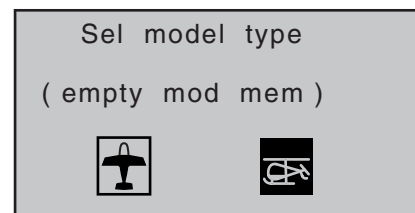

... the “Helicopter” model type. Confirm your choice by touching the central **SET** button of the right-hand touch-key, and the screen immediately switches to the basic display.

Notes:

- Once you have called up the “Model select” option it is not possible to interrupt the process, i.e. you must choose one or other model type. Even if you switch the transmitter off, then on again, you still have to make this choice. However, if you make a mistake you can always correct it simply by erasing the model memory.
- If the warning message “Throttle too high” appears, you can erase it by turning the rotary proportional knob CTRL 6 anti-clockwise to its end-point.
- If the battery voltage is too low, you will not be able to change model memories for safety reasons. In this case the screen displays an appropriate message:

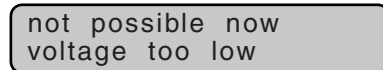

The memory should now be assigned an appropriate name, which is entered in the ...

“Basic settings” menu (pages 64 ... 71)

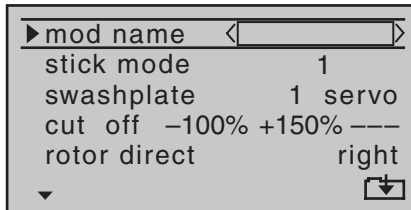

... using the characters which are available in the “Model name” line of the second menu page:



Once you have entered the “Model name” you should check that the “Stick mode” is correct:

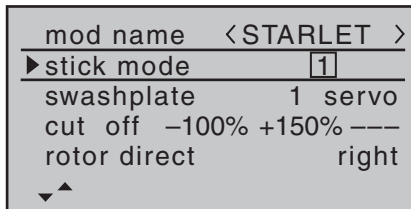

In the next four lines we come to the first settings which are specific to helicopters:

In the “Swashplate type” line select the number of servos which are used to actuate the swashplate. See page 67 for more details of this.

In the “Rotor direction” line we enter the direction of rotation of the main rotor as viewed from above. In the “Collective pitch min.” line set “forward” or “rear” to suit

your personal preference. This setting applies equally to all subsequent mixers, and it is therefore vital that you do not change it later in order to alter *individual mixer directions*, such as the direction of collective pitch or throttle.

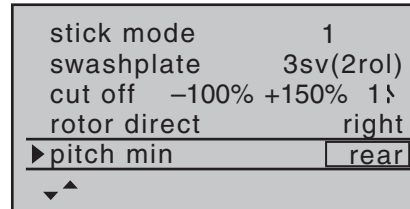

At this point, if you have not already done so, the servos should be connected to the receiver in the following sequence:

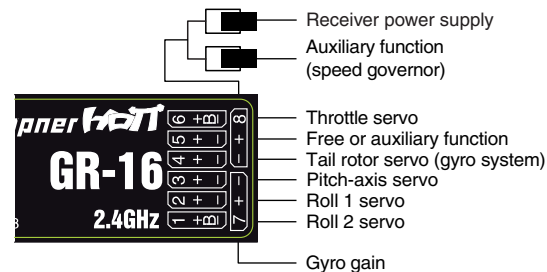

The mixer ratios and mixer directions for the swashplate servos for collective pitch, roll and pitch-axis are set in the ...

“Swashplate mixer” menu (page 112),

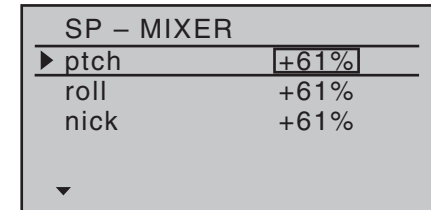

... where you will find that they are pre-set to +61% in each case. If the swashplate does not respond correctly to the stick movements, the first step is to change the mixer directions from “+” to “-” if necessary. The second recourse is to reverse the servo directions in the “Servo settings” menu.

Note:

Please note one important difference in later Graupner mc and mx radio control systems compared with earlier equipment: the first collective pitch servo and the throttle servo have been interchanged.

Now move to the ...

“Servo settings” menu (page 72),

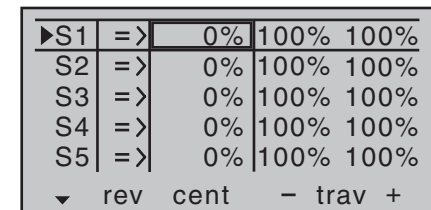

... where you can set up the travels and directions of rotation of the individual servos. The basic aim here should be to keep servo travels at 100% wherever possible, as this maintains best possible resolution and accuracy. Use “Rev.” if necessary to change the direc-

tion of rotation of any servo; do check carefully that the direction you set really is correct. The tail rotor servo, in particular, must operate in such a way that the nose (!) of the helicopter moves in the direction which corresponds to the movement of the tail rotor stick.

A glance at the ...

“Transmitter control settings” menu (page 76)

E5	free	+100%	+100%
Gas	free	+100%	+100%
Gyr	free	+100%	+100%
E8	free	+100%	+100%
▶ Lim	ctrl6	+100%	+100%
▲		- trv	+

... will show you that transmitter control “6”, i.e. the rotary proportional control CTRL 6, is assigned to the “Lim” input, whereas all other inputs are programmed to “free” by default. The “Lim” input serves as **throttle limiter**. It acts solely on output “6”, to which the throttle servo is connected.

Just to remind you:

- Using the “Throttle limiter” function eliminates the need to program an “Idle-up” flight phase.
- The throttle limiter does not control the throttle servo; it simply limits the travel of this servo in the forward direction, according to the setting of the throttle limiter, when required. The throttle servo is usually controlled by the collective pitch stick via the throttle curve or curves you have set in the **“Helimix”** menu, for which reason input 6 should always be left “free”. For more details please refer to the sections on pages 96 and 97 of the manual.
- Moreover the Ch 1 trim only affects a helicopter’s

throttle servo. This section does not describe the special features of this trim (“cut-off trim”) again, as it is covered on page 40. (Thanks to the digital trims, trim values are automatically stored when you switch models and when you switch between flight phases.)

- You will find a detailed description of the basic idle set-up procedure and the method of adjusting idle and throttle limit in the section starting on page 79.

Now use the arrow button ▶ of the left or right-hand touch-key to move to the “Travel” column, and increase the value in the highlighted field from 100% to 125%, with the throttle limiter at its forward end-stop.

E5	free	+100%	+100%
Gas	free	+100%	+100%
Gyr	free	+100%	+100%
E8	free	+100%	+100%
▶ Lim	ctrl6	+100%	+125%
▲		- trv	+

This ensures that the throttle limiter cannot possibly restrict the full throttle travel dictated by the collective pitch stick when the model is in flight.

Set-up note for electric helicopters:

Since electric motors by their nature require no idle setting, the only important point when setting up an electric-powered model helicopter is that the adjustment range of the throttle limiter should be set significantly higher and lower than the adjustment range of the speed controller, which is usually from -100% to +100%. It may therefore be necessary to adjust the “Travel” value of the throttle limiter to an appropriate value, such as a symmetrical 110% setting. However, further fine-tuning can be carried out exactly as described here for the glow-powered machine.

An additional function needs to be activated in the ...

“Basic model settings” menu (pages 64 ... 71).

Even if you are a beginner to flying and are not yet ready for this, it is advisable at least to define the auto-rotation switch, so that you have an “emergency cut” switch for the motor. This is carried out by selecting the **“Auto-rotation”** line using the arrow buttons ▲ ▼ of the left or right-hand touch-key, briefly touching the central **SET** button of the right-hand touch-key, and then moving one of the two-position switches (SW 2 or 8) to the “ON” setting. The switch number (in our example “2”) now appears on the right of the screen.

pitch min		rear
timer	5:00	C3↓
phase 2	hover	---
phase 3	speed	---
▶ autorotat.		2↑
▲		↙

This switch should be located at a position on the transmitter where you can easily reach it without letting go of the stick, e.g. above the collective pitch stick.

Note:

For more information on setting up this “emergency OFF switch” please refer to the section in the centre column of the following page.

And another tip:

Please make it a habit to give all the switches a common “on” direction; then a quick glance at the transmitter before flying will soon reassure you that all switches are “off”.

If you wish, you could at this point move up two lines

and assign a flight phase switch for flight phase 2, which is already assigned the name “Hover”, but this simple programming example deliberately excludes such refinements.

You have now completed the basic settings at the transmitter, i.e. the procedure which you will need to use time and again when setting up a new model. The actual helicopter-specific set-up is carried out primarily in the ...

“Heli mixers” menu (pages 94 ... 105).

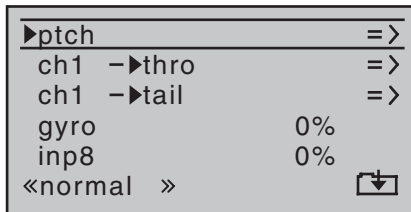

In the very first line you will see the “Collective pitch” function, and a brief press on the central **SET** button of the right-hand touch-key takes you to the appropriate sub-menu. At this point you will see a graphic representation of the collective pitch curve. This is initially defined by only three reference points, and in most cases this is quite adequate.

Tip:

Always try to manage with these three reference points initially, as additional points just complicate matters, and extra complexity is just what you don't need at the moment.

The reference point for hovering should generally be the mechanical centre-point of the collective pitch stick, as this position feels completely natural to most pilots. You can, of course, set up the curve to locate the hover at a different point, but you should not be tempted to do this

unless you know exactly what you are doing. Start by setting the collective pitch stick to centre. Assuming that you previously adjusted the servos in accordance with the manufacturer's instructions, the servo output arms will now (usually) be at right-angles to the servo case. If you have not already done so, adjust the mechanical linkages to the rotor head so that all the blades are set to a collective pitch angle of 4° to 5° positive for the hover. All known helicopters will fly at this setting.

Now push the collective pitch stick fully forward to the maximum collective pitch point (the full-length vertical line indicates the current position of the stick). Adjust Point 5 on the collective pitch curve using the arrow buttons of the right-hand touch-key, with the aim of obtaining a maximum collective pitch setting of around 9° at the main rotor blades. This point should be at a value of around +50%.

Note:

A rotor blade set-up gauge, e.g. the Graupner item, Order No. 61, is very useful when setting up blade pitch angles, as you can read off the angles directly.

Now pull the collective pitch stick right back to the collective pitch minimum position. Set the blade pitch angle for Point 1 to 0 to -4°, depending on your piloting ability. This produces a graph line with a slight angle at the hover point, forming what is known as the collective pitch curve. It might look approximately like this:

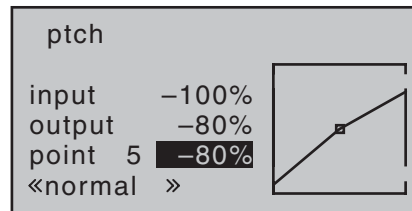

If you now switch to the auto-rotation phase - you will see the name of the flight phase “Autorot” at bottom left on the screen - the “old” collective pitch curve will re-appear. In this phase you should set the same values as in the normal phase, with the following exception: increase the pitch angle at Point 5 (collective pitch maximum) by about 2°. This gives slightly more pitch for flaring the model when practising “autos” at a later (!) date.

Once you have set up the collective pitch curve, operate the auto-rotation switch again, then briefly touch the central **ESC** button of the left-hand touch-key to return to the helicopter mixer menu select point. Now we move on to the “Ch1 → thro” line, where you can set up the throttle curve.

The first step here is to enter the idle trim range by adjusting the throttle curve. Move the collective pitch stick to the minimum position, and set Point 1 to a value of around -65%.

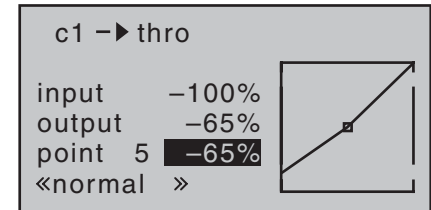

With the throttle limiter *closed* and the idle trim fully open, pull the collective pitch stick to the “fully back” position and move it slightly to and fro: the throttle servo should not respond to this movement. This arrangement gives you a seamless transition from idle trim to the throttle curve. You will probably need to make further adjustments to the throttle curve, but this process must be carried out later as part of the flight-testing procedure.

If you now switch temporarily from this graph to the

auto-rotation flight phase, you will see - instead of the usual display - the following:

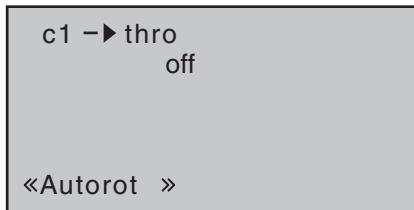

This means that the throttle servo has switched to a fixed value, which can be adjusted as follows:

Press **ESC** to return to the menu list. Assuming that you are still in the auto-rotation phase, this will now include new sub-menus.

The important line is "Throttle", where you should set a value of around +125% or -125%, depending on the direction of servo rotation.

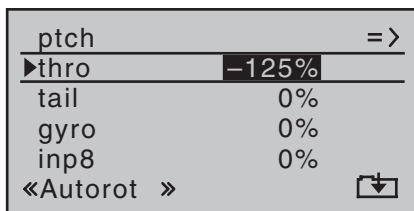

This setting ensures that the motor stops reliably in the auto-rotation phase (to allow you to cope with an emergency). Later, when you have gained sufficient experience to practise auto-rotation landings, the setting should be changed to a value which provides a reliable idle.

Set-up note for electric helicopters:

Since the motor must be stopped completely if an emergency occurs with an electric-powered model helicopter, this setting can be adopted unchanged.

At present the remaining sub-menus are of no interest. Simply switch "Auto-rotation" off, and move back to the first menu list.

Call up the set-up page of the "Ch1 → tail rotor" menu: this is where you set static torque compensation (DMA) for the tail rotor. Once again, please restrict yourself to the three default reference points; everything else is the preserve of the experienced pilot. For the initial set-up - intended for a heading-lock gyro system - the uniform pre-set values of 0% should be changed to -30% at Point 1 (collective pitch minimum) and +30% at the opposite end, Point 5 (collective pitch maximum), although you may find it necessary to adjust the settings slightly later.

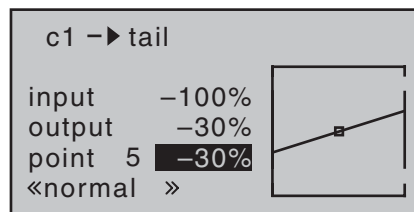

Now switch back to the auto-rotation phase for a moment. The set-up curve is disabled here, with the result that the tail rotor servo no longer responds to collective pitch commands (when the main rotor is not powered, there is no rotor torque to be corrected).

The - static - pre-set of the gyro effect principle ("normal" or "heading lock" mode), and also the gyro gain can now be altered by setting a value other than "0" in the "Gyro" line:



Please be sure to read and observe the set-up instructions supplied with your gyro at this point, as there is a possibility that your helicopter will be uncontrollable if you set it up incorrectly!

If your gyro features gain control from the transmitter - unlike the type we are using in this example - you will need another free proportional control for it, e.g. CTRL 7. This can be assigned to the "Gyro" input in the ...

"Transmitter control settings" menu (page 76).

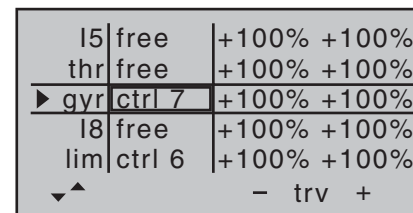

Turn the rotary control until its number (transmitter control number) appears on the screen, then use the arrow button ▶ of the left or right-hand touch-key to move to the **ASY** field in the "Travel" column. Briefly press the central **SET** button of the right-hand touch-key, and you will be able to set a maximum gyro gain such as 50% in the now highlighted field:

15	free	+100%	+100%
thr	free	+100%	+100%
► gyr	ctrl 7	+50%	+50%
18	free	+100%	+100%
lim	ctrl 6	+100%	+100%
▼▲		- trv	+

This represents a safe fixed value which is maintained as long as the rotary control is at its right-hand end-stop. You will probably need to adjust the value in the course of flight-testing. Additional notes on setting up gyros can be found on pages 98 / 99.

Further adjustments

If you have followed this programming example, you will have a helicopter which is set up properly, and in an ideal state for hovering practice and simple circuits. Of course, you may wish to activate further functions depending on your skill and flying experience. If you wish to fly using different rotor speeds and trim set-ups, you will need to activate a series of "flight phases", which can be called up via switches which you assign. The first step in this process is to call up the ...

"Basic model settings" menu (pages 64 ... 71),

pitch min		rear
timer	10:01	C3↓
► phase 2	hover	8↓
phase 3	acro	---
autorotat.		2↓
▼▲		↘

... assign a switch to "Phase 2", e.g. SW 8, and enter a relevant name (if you wish).

It is important to be quite clear in your mind that auto-

rotation always has *absolute precedence* over any other phases. This simply means: if you operate the auto-rotation switch, you immediately move to the auto-rotation phase from either of the other two flight phases ("normal" phase and "phase 2").

Now move back to the "Helimix" menu, switch to "Phase 2" (which you have just set up), and modify the settings accordingly. Since the **mx-16** HoTT features digital trims, in the Heli program all the trim positions for the control functions "roll", "pitch-axis" and "tail rotor" are stored separately for each flight phase, in addition to the other menu settings which you entered separately for each flight phase (see page 94).

For example, if the motor run is limited by the fuel tank size or battery capacity, you should set the stopwatch to count down. Enter the maximum possible motor run time, e.g. "5 min.". The transmitter's sounder now starts emitting warning sounds starting at "30 s" before "zero", as described on page 67 / 68. You could assign the transmitter control switch "G3" to this timer, by first activating switch assignment and then turning the throttle limit control from its idle position in the direction of full-throttle:

swashplate	3sv(2rol)
cut off	-100% +150% 1↓
rotor direct	right
pitch min	rear
► timer	5:00 C3↓
▼▲	

With the stopwatch halted, touch the ▲▼ or ◀▶ buttons of the left-hand touch-key (**CLEAR**) simultaneously at the basic display, so that the stopwatch switches to the "Timer" function. The timer then starts automatically

when you move the throttle limit slider towards full-throttle, and stops again when you move the limiter back to the idle range.

Suggested refinement: speed governor

At some time you may wish to install a speed governor (regulator) in your helicopter, e.g. the mc-Heli-Control, to try flying with a system rotational speed which is automatically maintained at a constant value. It makes sense to couple the individual rotor speeds with the flight phases, as this enables you to carry out further fine-tuning.

The initial requirement when programming the transmitter is to install and program the speed governor exactly in accordance with the manufacturer's instructions. Of course, the **mx-16** HoTT provides further facilities to allow you to implement different rotational speeds in the individual flight phases. A practical suggestion, which includes the throttle limiter function, can be found in the section starting on page 97.

If you have set up your helicopter as described in this programming example, you will find that it is capable of carrying out extremely challenging flight tasks even though it is not suitable for competition work.

We suggest that you should not make use of additional functions until your model is flying perfectly, so that you will be in a position to recognise and appreciate any improvements. Whenever possible, it is always best to implement additional refinements one at a time, otherwise you won't know which change has brought about any improvement. Bear in mind that the good pilot is not recognised by the number of complex functions with which he can cope, but by the results he can obtain when flying a relatively simple set-up.

Appendix



PRX (Power for Receiver)

Order No. 4136

A highly developed stabilised receiver power supply with intelligent power management.

The unit constitutes a stabilised user-selectable power supply for the receiver, and provides a further enhancement in the reliability of the airborne power supply. It is designed for use with different types of receiver battery, to ensure that it is straightforward and versatile in use. When the model is operating, even brief collapses in battery voltage are stored and displayed, offering the user the means of detecting a receiver battery which is not "up to the job", or failing.

- For use with one or two receiver batteries (simultaneous discharge if two batteries are employed)
- Suitable for five-cell or six-cell NiMH batteries, or two-cell LiPo or LiFe packs. *Graupner/JR*, G3.5, G2 and BEC connector systems.
- Three user-selectable receiver power voltage levels: 5.1 V / 5.5 V / 5.9 V.
- Two ultra-bright LEDs indicate the operational status of batteries 1 and 2 separately.
- Integral high-quality On / Off switch.
- Constructed to cope with high-current applications.
- Low-profile switch and LEDs to avoid spoiling the appearance and efficiency of the model.
- Straight-through design of mounting lugs, LEDs and switch for simple installation using drilling template (supplied).



Graupner HoTT GPS / Vario module

Order No. 33600

Vario with altitude signals and five different tones for climb and descent, plus GPS with range measurement, distance measurement, speed indicator, display of flight direction and co-ordinates

- Additional warning thresholds for min. altitude, max. altitude, two-stage climb and descent rate
- Altitude display, storage of min. and max. altitude
- Variable warning time: OFF, 5, 10, 15, 20, 25, 30 seconds, constant
- Variable warning repeat time: constant, 1, 2, 3, 4, 5 min, once
- The GPS / Vario sensor can be connected directly to the receiver's telemetry input.

Specification, vario

- Altitude measurement: -500 m ... +3000 m
- Resolution: 0.1 m
- Sensitivity, vario: 0.5 m/3s, 1 m/3s, 0.5 m/s, 1 m/s, 3 m/s, programmable per beep
- Calculated average value: 4 - 20 measurements per measured value, programmable



Graupner HoTT Vario module

Order No. 33601

Vario with altitude signals and five different tones for climb and descent; altitude display and storage of min. and max. altitude.

- Additional warning thresholds for min. altitude, max. altitude, two-stage climb and descent rate
- Variable warning time: OFF, 5, 10, 15, 20, 25, 30 seconds, constant
- Variable warning repeat time: constant, 1, 2, 3, 4, 5 min, once
- The vario sensor can be connected directly to the receiver's telemetry input.

Specification

- Altitude measurement: -500 m ... +3000 m
- Resolution: 0.1 m
- Sensitivity, vario: 0.5 m/3s, 1 m/3s, 0.5 m/s, 1 m/s, 3 m/s, programmable per beep
- Calculated average value: 4 - 20 measurements per measured value, programmable



Graupner HoTT General Engine Module

Order No. 33610

General sensor for *Graupner* HoTT receivers and models with internal-combustion or electric power system:

- 2 x temperature and voltage measurements with warning thresholds for min. and max. voltage and min. and max. temperature
- Individual cell measurement with min. voltage warning thresholds
- Voltage, current and capacity measurement with warning thresholds for min. and max. voltage, max. capacity and max. current
- Programmable current limiting
- Current measurement with 2 x 1 mOhm shunt resistors in parallel = 0.5 mOhm
- Rev-count measurement and warning thresholds for min. and max. rotational speed
- Fuel measurement with warning thresholds in 25% increments (requires software update)
- User-variable warning time: OFF, 5, 10, 15, 20, 25, 30 seconds, constant
- User-variable warning repeat time: constant, 1, 2, 3, 4, 5 min, once
- 2 x temperature measurement, optionally 0 to 120°C or 200°C, also voltage measurement up to 80 V DC
- 1 x rev-count measurement up to 100,000 rpm with two-blade propeller
- 1 x speed controller / servo input, 1 x speed governor input, 1 x speed controller / servo output for rotational speed governor
- etc. see product at www.graupner.de

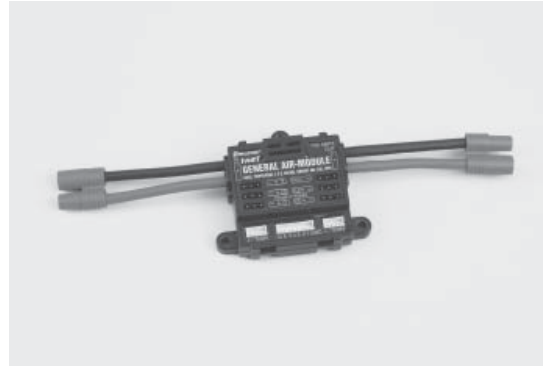

Graupner HoTT General Air Module

Order No. 33611

General sensor for *Graupner* HoTT receivers and models with internal-combustion or electric power system:

- Vario with altitude signals, climb and descent signals, and additional warning thresholds for min. altitude, max. altitude, climb and two-stage descent rate
- Altitude indicator (-500 ... +3000 m), storage of min. and max. altitude
- 2 x temperature and voltage measurements with warning thresholds for min. and max. voltage and min. and max. temperature
- Individual cell measurement with min. voltage warning thresholds
- Voltage, current and capacity measurement with warning thresholds for min. and max. voltage, max. capacity and max. current
- Rev-count measurement and programmable speed governor, also warning thresholds for min. and max. rotational speed
- Fuel measurement with warning thresholds in 25% increments (requires software update)
- User-variable warning time: OFF, 5, 10, 15, 20, 25, 30 seconds, constant
- User-variable warning repeat time: constant, 1, 2, 3, 4, 5 min, once
- 2 x temperature measurement, optionally 0 to 120°C or 200°C, also voltage measurement up to 80 V DC
- 1 x rev-count measurement up to 100,000 rpm with two-blade propeller
- etc. see product at www.graupner.de



Graupner HoTT Electric Air-Module

Order No. 33620

General sensor for *Graupner* HoTT receivers and electric-powered models:

- Vario with altitude signals, climb and descent signals, and additional warning thresholds for min. altitude, max. altitude, two-stage climb and descent rate
- Altitude indicator (-500 ... +3000 m), storage of min. and max. altitude.
- 2 x temperature and voltage measurements with warning thresholds for min. and max. voltage and min. and max. temperature
- Individual cell measurement 2 ... 14S with min. voltage warning thresholds
- Voltage, current and capacity measurement with warning thresholds for min. and max. voltage, max. capacity and max. current
- User-variable warning time: OFF, 5, 10, 15, 20, 25, 30 seconds, constant
- User-variable warning repeat time: constant, 1, 2, 3, 4, 5 min, once
- 2 x temperature measurement, optionally 0 to 120°C or 200°C, also voltage measurement up to 80 V DC
- 1 x speed controller input, 1 x speed controller output for power reduction due to low voltage of individual cells
- 1 x current, voltage and capacity measurement, up to 150 A (peak 1 sec. 320 A) and up to 60 V
- 1 x individual cell monitoring for 2 - 14S Lithium batteries (LiPo, Lilo, LiFe)
- etc. see product at www.graupner.de



Graupner HoTT RPM magnet sensor

Order No. 33616

Graupner HoTT RPM optical sensor

Order No. 33615



Graupner HoTT Smart-Box

Order No. 33700

A vast range of different functions combined in a single device: that's what destines the SMART-BOX to be your intelligent companion in future. Whether you want to display telemetry data in real time, or enter changes to your HoTT system, the large-area screen with 8 x 21 characters makes the task simple. The flexible Smart-Box includes an integral buzzer for generating audible signals and warnings for even greater flexibility and practicality.

The installation set supplied makes it easy to mount the unit on the support bars of hand-held transmitters, allowing you to position it in such a way that you can read off telemetry data in real time while you control your model.

The user-update facility ensures that the SMART-BOX is always up-to-date, and provides a route for expanded functions in future.

- Transmitter voltage display with user-variable warning threshold
- Range check
- Receiver temperature
- Servo reverse
- Servo travel
- Channel swap
- Mixer settings
- Country setting
- Signal quality
- Receiver voltage
- Servo neutral position
- Cycle time
- Fail-Safe settings
- Servo test

Dimensions: approx. 76 mm x 72 mm x 17 mm (L x W x H)

Weight: approx. 55g

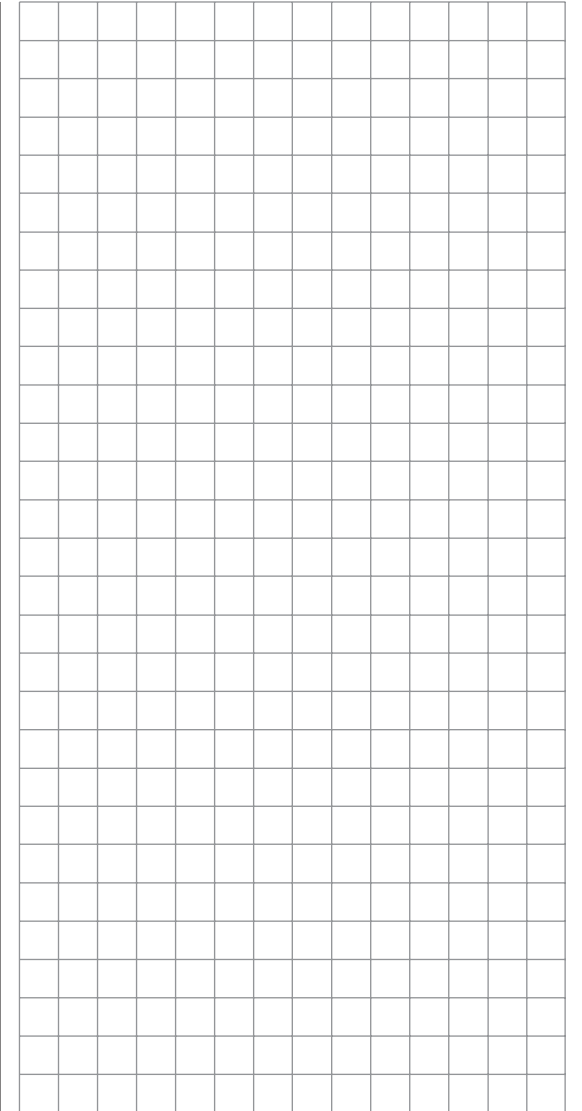

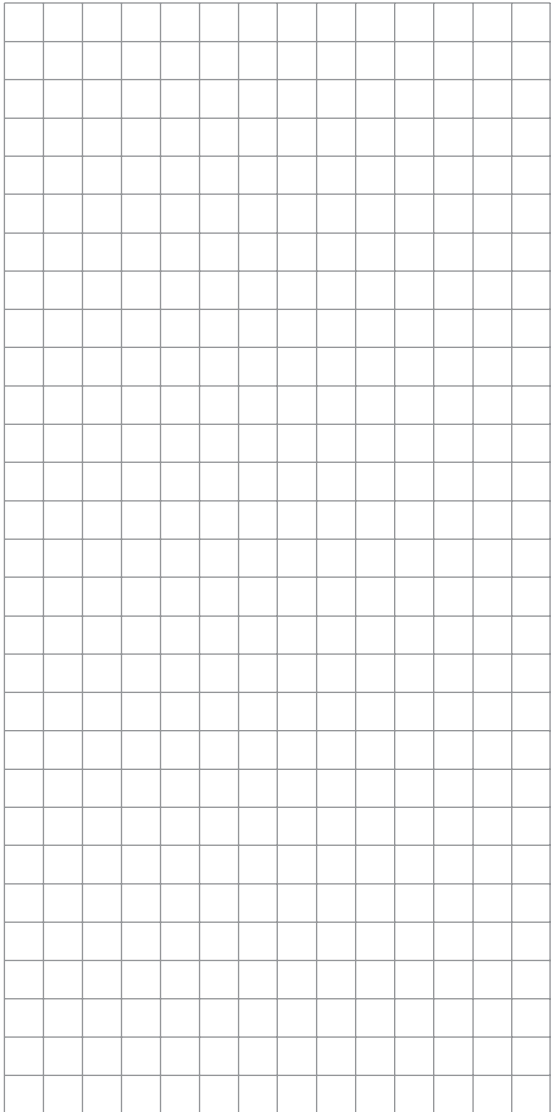
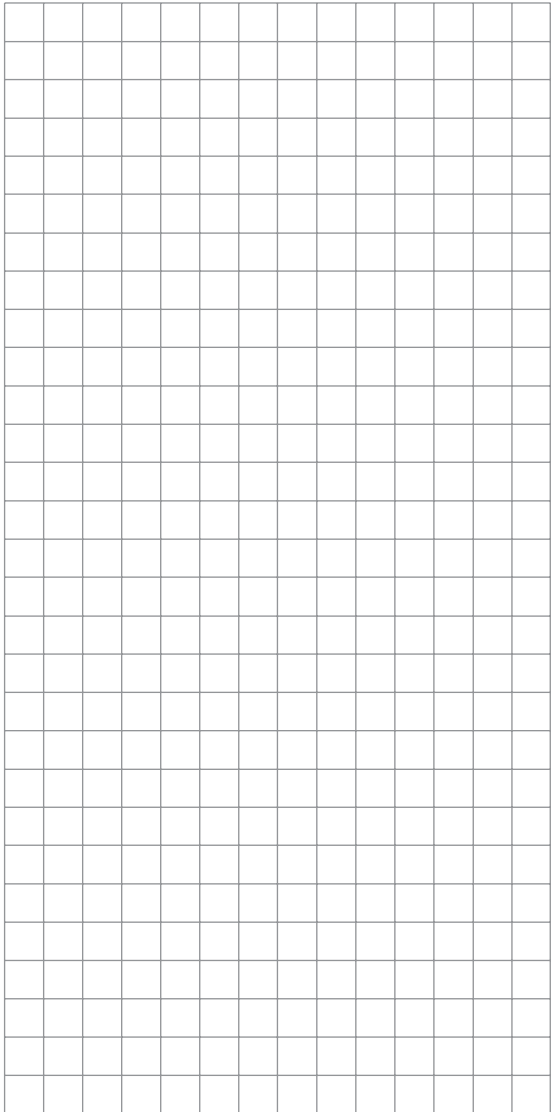
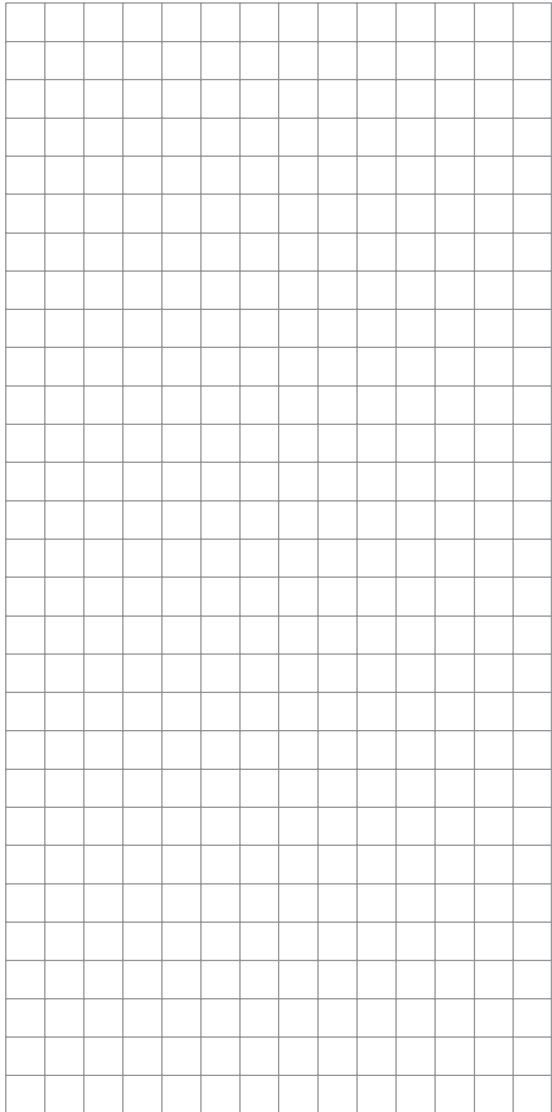

Graupner

Guarantee certificate

Wir gewähren auf dieses Erzeugnis eine Garantie von
This product is warranted for
Sur ce produit nous accordons une garantie de

24 Monaten
months
mois

Servicestellen / Service / Service après-vente

Graupner-Zentralservice

Graupner GmbH & Co. KG
Henriettenstrasse 94 - 96
D-73230 Kirchheim

Servicehotline

☎ (+49) 0 18 05 47 28 76*
Montag - Freitag
9:30-11:30 + 13:00-15:00 Uhr

Belgie/Belgique/Nederland

Jan van Mouwerik
Slot de Houvelaan 30
NL 3155 Maasland VT
☎ (+31) 10 59 13 59 4

Luxembourg

Kit Flamang
129, route d'Arlon
L 8009 Strassen
☎ (+35) 23 12 23 2

Česká Republika Slovenská Republika

RC Service Z. Hnizdil
Letecka 666/22
CZ 16100 Praha 6 - Ruzyně
☎ (+42) 2 33 31 30 95

Schweiz

Graupner Service
Wehntalerstrasse 37
CH 8181 Höri
☎ (+41) 43 26 66 58 3

Espana

Anguera Hobbies
C/Terrassa 14
E 43206 Reus (Tarragona).
☎ (+34) 97 77 55 32 0
info@anguera-hobbies.com

Sverige

Baltechno Electronics
Box 5307
S 40227 Göteborg
☎ (+46) 31 70 73 00 0

France

Graupner France
Gérard Altmayer
86, rue St. Antoine
F 57601 Forbach-Oeting
☎ (+33) 3 87 85 62 12

United Kingdom

Graupner Service
Brunel Drive
GB, NEWARK, Nottinghamshire
NG242EG
☎ (+44) 16 36 61 05 39

Italia

GiMax
Via Manzoni, no. 8
I 25064 Gussago
☎ (+39) 030 25 22 73 2

* 0,14 Cent / Minute aus dem Festnetz der deutschen T-Com. Abweichende Preise für Anrufe aus Mobilfunknetzen oder aus dem Festnetz anderer Anbieter möglich.

Die Fa. *Graupner* GmbH & Co. KG, Henriettenstraße 94 - 96, D-73230 Kirchheim/Teck gewährt ab dem Kaufdatum auf dieses Produkt eine Garantie von 24 Monaten. Die Garantie gilt nur für die bereits beim Kauf des Produktes vorhandenen Material- oder Funktionsmängel. Schäden, die auf Abnutzung, Überlastung, falsches Zubehör oder unsachgemäße Behandlung zurückzuführen sind, sind von der Garantie ausgeschlossen. Die gesetzlichen Rechte und Gewährleistungsansprüche des Verbrauchers werden durch diese Garantie nicht berührt. Bitte überprüfen Sie vor einer Reklamation oder Rücksendung das Produkt genau auf Mängel, da wir Ihnen bei Mängelfreiheit die entstandenen Unkosten in Rechnung stellen müssen.

Graupner GmbH & Co. KG, Henriettenstraße 94 - 96, D-73230 Kirchheim/Teck, Germany guarantees this product for a period of 24 months from date of purchase. The guarantee applies only to such material or operational defects which are present at the time of purchase of the product. Damage due to wear, overloading, incompetent handling or the use of incorrect accessories is not covered by the guarantee. The user's legal rights and claims under guarantee are not affected by this guarantee. Please check the product carefully for defects before you are make a claim or send the item to us, since we are obliged to make a charge for our cost if the product is found to be free of faults.

La société *Graupner* GmbH & Co. KG, Henriettenstraße 94-96, D-73230 Kirchheim/Teck, accorde sur ce produit une garantie de 24 mois à compter de la date d'achat. La garantie ne s'applique qu'aux défauts de matériel et de fonctionnement du produit acheté. Les dommages dus à une usure, à une surcharge, à l'emploi d'accessoires non compatibles ou à une manipulation non conforme sont exclus de la garantie. Cette garantie ne remet pas en cause les droits légaux des consommateurs. Avant toute réclamation ou retour de matériel, vérifiez précisément les défauts ou vices constatés, car si le matériel est conforme et qu'aucun défaut n'a été constaté par nos services, nous nous verrions contraints de facturer le coût de cette intervention.

Garantie-Urkunde

Warranty certificate / Certificat de garantie

mx-16 HoTT Set

Order No. **33116**

Übergabedatum:

Date of purchase/delivery:

Date d'achat :

Name des Käufers:

Owner's name:

Nom de l'acheteur :

Straße, Wohnort:

Complete address:

Adresse complète :

Firmenstempel und Unterschrift des Einzelhändlers:

Stamp and signature of dealer:

Cachet et signature du détaillant :



FCC Information

Graupner mx-16 HoTT

FCC ID: **ZKZ-MX-16-20A**

FCC statement

1. This device complies with Part 15 of the FCC Rules. Operation is subject to the following two conditions:
 - (1) This device may not cause harmful interference.
 - (2) This device must accept any interference received, including interference that may cause undesired operation.
2. Changes or modifications not expressly approved by the party responsible for compliance could void the user's authority to operate the equipment.



NOTE

This equipment has been tested and found to comply with the limits for a Class B digital device, pursuant to Part 15 of the FCC Rules. These limits are designed to provide reasonable protection against harmful interference in a residential installation. This equipment generates uses and can radiate radio frequency energy and, if not installed and used in accordance with the instructions, may cause harmful interference to radio communications. However, there is no guarantee that interference will not occur in a particular installation. If this equipment does cause harmful interference to radio or television reception, which can be determined by turning the equipment off and on, the user is encouraged to try to correct the interference by one or more of the following measures:

- Reorient or relocate the receiving antenna.
- Increase the separation between the equipment and receiver.

- Connect the equipment into an outlet on a circuit different from that to which the receiver is connected.
- Consult the dealer or an experienced radio/TV technician for help.

FCC radiation exposure statement:

This equipment complies with FCC radiation exposure limits set forth for an uncontrolled environment. This equipment should be installed and operated with minimum distance 20cm between the radiator & your body

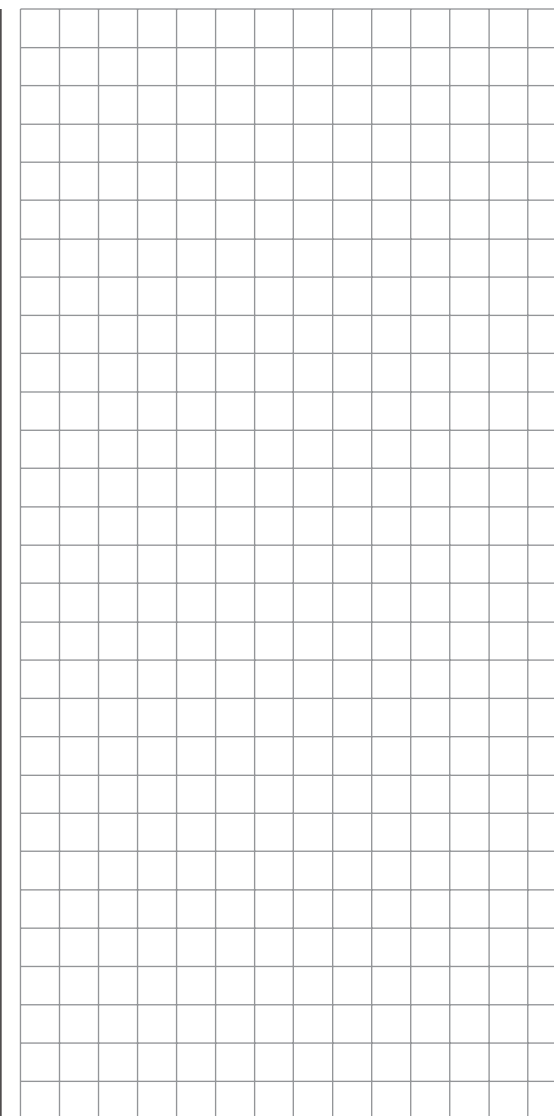

Graupner

HOPI

HOPPING . TELEMETRY . TRANSMISSION

GRAUPNER GMBH & CO. KG
POSTFACH 1242
D-73220 KIRCHHEIM/TECK
GERMANY

<http://www.graupner.de>

Modifications and availability reserved. *Graupner* products are only available through model shops. We will gladly inform you of your nearest stockist. We accept no liability for printing errors.

Printed in Germany PN.PC-01

Although we have carefully checked the information contained in these instructions and checked that it is correct, we can accept no liability of any kind for mistakes, incomplete information and printing errors. *Graupner* reserves the right to alter the characteristics and features of the software and hardware at any time and without prior notification.