



## Wireless Gateway Owner's Manual

Model: GRJW05-J

FCC ID: 2ADAP-W05AGL

IC: 12478A-W05AGL

---

---

Gree Electric Appliances, Inc. of Zhuhai



- Please read this manual carefully before operation and keep it well for future reference.
- Due to product improvement, Gree reserves the right to change contents of this manual without prior notice.
- Gree Electric Appliances, Inc. of Zhuhai reserves the final right to interpret this manual.





## User Notices

Dear Users:

Please read this manual carefully before installation and operation and strictly observe the installation and operation instructions covered in this manual. In addition, careful attention shall be drawn to the following symbols.

|   |  |
|---|--|
|  <b>WARNING</b> | It indicates, if operated improperly, it would lead to bodily injury or severe damage. |
|  <b>CAUTION</b> | It indicates, if operated improperly, it would lead to damage of unit.                 |

|  <b>WARNING</b>  |
|---|
| (1) Installation shall be performed by the qualified personnel; otherwise it would result in a fire hazard or electric shock.   |
| (2) Do not place the plug of the power supply into the socket before it is dried and cleaned.   |
| (3) Cut off the power supply of gateway before touching the electric element.   |
| (4) Do not touch this device with wet hands, otherwise it would result in electric shock.   |
| (5) Do use the power cord provided with the gateway. A fire hazard would happen when the connection or installation is in poor condition.   |
| (6) Do install the gateway where it will not be subject to the electromagnetic interference or heavy dust.  |
| (7) Do install the gateway inside the electric control cabinet which is locked.   |
|  <b>CAUTION</b>  |
| (1) Be sure proper power supply is provided; otherwise this device would work improperly or even be damaged.  |
| (2) Be sure this device is setup in place; otherwise it would result in communication error.  |
| (3) Be sure the communication cable is connected to the correct interface; otherwise it would result in communication error.  |
| (4) After connection, wires should be protected with insulation tape to avoid oxidation and short circuits.   |
| (5) Normal working conditions: ① Temperature: -20 ~ +50°C; ② Humidity: less than 85%; ③ Location: inside the electric control cabinet which is placed indoors, not subject to direct sunlight, rain and snow etc. |



## FCC WARNING

WARNING: Changes or modifications to this unit not expressly approved by the party responsible for compliance could void the user's authority to operate the equipment.



## FCC STATEMENT

This device complies with Part 15 of the FCC Rules. Operation is subject to the following two conditions : (1) this device may not cause harmful interference, and (2) this device must accept any interference received, including interference that may cause undesired operation.

NOTE: This equipment has been tested and found to comply with the limits for a Class B digital device, pursuant to part 15 of the FCC Rules. These limits are designed to provide reasonable protection against harmful interference in a residential installation. This equipment generates, uses and can radiate radio frequency energy and, if not installed and used in accordance with the instructions, may cause harmful interference to radio communications.

However, there is no guarantee that interference will not occur in a particular installation. If this equipment does cause harmful interference to radio or television reception, which can be determined by turning the equipment off and on, the user is encouraged to try to correct the interference by one or more of the following measures:

- Reorient or relocate the receiving antenna.
- Increase the separation between the equipment and receiver.
- Connect the equipment into an outlet on a circuit different from that to which the receiver is connected.
- Consult the dealer or an experienced radio/TV technician for help.



## IC STATEMENT

This device complies with Industry Canada licence-exempt RSS standard(s). Operation is subject to the following two conditions: (1) this device may not cause interference, and (2) this device must accept any interference, including interference that may cause undesired operation of the device.

Le présent appareil est conforme aux CNR d'Industrie Canada applicables aux appareils radio exempts de licence. L'exploitation est autorisée aux deux conditions suivantes : (1) l'appareil ne doit pas produire de brouillage, et (2) l'utilisateur de l'appareil doit accepter tout brouillage radioélectrique subi, même si le brouillage est susceptible d'en compromettre le fonctionnement.

This equipment complies with FCC's and IC's RF radiation exposure limits set forth for an uncontrolled environment. The antenna(s) used for this transmitter must be installed and operated to provide a separation distance of at least 20 cm from all persons and must not be collocated or operating in conjunction with any other antenna or transmitter. Installers must ensure that 20cm separation distance will be maintained between the device (excluding its handset) and users.

Cet appareil est conforme aux limites d'exposition au rayonnement RF stipulées par la FCC et l'IC pour une utilisation dans un environnement non contrôlé. Les antennes utilisées pour cet émetteur doivent être installées et doivent fonctionner à au moins 20 cm de distance des utilisateurs et ne doivent pas être placées près d'autres antennes ou émetteurs ou fonctionner avec ceux-ci. Les installateurs doivent s'assurer qu'une distance de 20 cm sépare l'appareil (à l'exception du combiné) des utilisateurs.

# Content

|   |   |
|---|---|
| 1 General Functions .....                   | 1 |
| 2 Check before Installation .....           | 1 |
| 3 Detailed Instruction of Gateway .....     | 1 |
| 3.1 interfaces.....                         | 1 |
| 3.1.1 Interface Drawing .....               | 1 |
| 3.1.2 Power Supply.....                     | 2 |
| 3.1.3 Communication Interfaces.....         | 2 |
| 3.1.4 DI/AI Input.....                      | 2 |
| 3.2 LED Display .....                       | 3 |
| 3.3 DIP Switches.....                       | 3 |
| 3.3.1 Diagram of DIP Switches .....         | 4 |
| 3.4 Buttons .....                           | 4 |
| 4 Function Instruction .....                | 4 |
| 4.1 CAN Function.....                       | 4 |
| 4.2 WiFi Function .....                     | 5 |
| 4.2.1 Flowchart of System Control .....     | 5 |
| 4.2.2 Download and Installation .....       | 5 |
| 4.3 Steps of Communication Connection ..... | 5 |
| 4.4 Connect device to network.....          | 6 |
| 5 Installation.....                         | 8 |
| 5.1 Product Dimension.....                  | 8 |
| 5.2 Installation Space.....                 | 8 |

## 1 General Functions

The wireless gateway connects with the units by CAN, for realizing the wireless communication between intelligent devices (such as smart phone, tablet PC) and units. Intelligent devices can check or control the unit's status by gateway.

## 2 Check before Installation

The product contains following items. Please check them prior to installation.

|                |        |
|----------------|--------|
| Gateway        | 1set   |
| Owner's Manual | 1piece |
| power cord     | 1piece |

## 3 Detailed Instruction of Gateway

### 3.1 Interfaces

#### 3.1.1 Interface Drawing



### 3.1.2 Power Supply



The power input should be 100VAC-240VAC, 50/60Hz.

**⚠ Warning: Do not touch the power input when the gateway is energized.**

### 3.1.3 Communication Interfaces



"RS485-3": Communication interface reserved.

"RS485-2": Communication interface reserved.

"RS485-1": Communication interface reserved.

"CAN": CAN communication interface. It is used to connect the indoor and outdoor unit through CAN bus.

"ETHERNET": ETHERNET port reserved.



"SD": SD card interface for program record and upgrade. It is reserved.

"USB": USB interface, for program record and upgrade.

"MICRO": MICRO\_USB interface, with the same functions as USB interface, adaptable for various USB interface models.

### 3.1.4 DI/AI Input

The product doesn't use this communication interface temporarily, **It is reserved.**

"D1": Digital input

"D2": Digital input

"A1": Analog input



"AI2": Analog input



### 3.2 LED Display



|         |    |   |
|---------|----|---|
| CAN     | TX | It flashes when the gateway sends data to CAN bus.        |
|         | RX | It flashes when the gateway receives data from CAN bus.   |
| RS485-1 | TX | It flashes when the gateway sends data to RS485 bus.      |
|         | RX | It flashes when the gateway receives data from RS485 bus. |
| RS485-2 | TX | It flashes when the gateway sends data to RS485 bus.      |
|         | RX | It flashes when the gateway receives data from RS485 bus. |
| RS485-3 | TX | It flashes when the gateway sends data to RS485 bus.      |
|         | RX | It flashes when the gateway receives data from RS485 bus. |
| POWER   |    | It lights on when the gateway is powered normally.        |
| RUN     |    | It flashes when the gateway is in normal operation.       |
| ERROR   |    | It flashes when the gateway has an error.                 |
| A/D     |    | It flashes after pressing reset button for 5s.            |

### 3.3 DIP Switches

This gateway includes two kinds of DIP switches, "address" DIP switch and "function" DIP switch. This function is reserved.



### 3.3.1 Diagram of DIP Switches

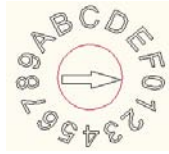

## 3.4 Buttons



"INIT": It is reserved.

"RESET": System restarts.

## 4 Function Instruction

### 4.1 CAN Function

L1: L1 as shown in the figure is the CAN1 bus, which is made up of indoor units and outdoor units in the system.

GREE+APP

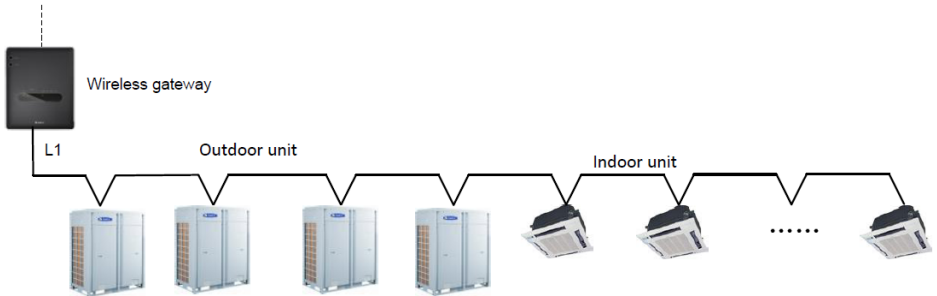

## 4.2 WiFi Function

WiFi function can be operated by matching with GREE+APP, to realize intelligent control for devices.

### 4.2.1 Flowchart of System Control

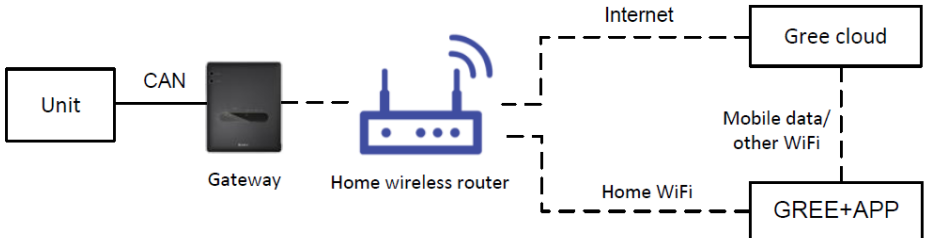

### 4.2.2 Download and Installation

Requirements for user's smart phone:



IOS System  
support ios 7.0 and above version



Android System  
Support Android4.0 and above version

(1) Download the APP and then install it. After that, please register and account. Once devices are added, long-distance control and LAN control for the unit can be realized

(2) Scan below QR code to download and install it.



#### Note

Along with the upgrade of products, the content and the interface of GREE+APP may be different from that on the instruction manual. Please refer to the present APP.

## 4.3 Steps of Communication Connection

Step 1: Select the installation position for gateway according to the actual situation. Select the CAN bus of indoor

unit or outdoor unit to connect communication line and CAN interface.

Step 2: Energize the air conditioner and the gateway.

Step 3: Check the status of communication indicator. If CAN\_RX indicator is flashing, it indicates the gateway can receive the data sent from the unit; if it doesn't flash, please check the connection of communication line. A/D indicator is flashing and the gateway is under network connection status. Use APP to connect the gateway to the hotspot of router.

Introduction of communication interface please refer to "3.1.3 Communication Interfaces".

#### 4.4 Connect device to network

Operation method for adding devices: Click icon "+" in the top right corner of the main interface in figure 1, click to select "air conditioner" device in figure 2, reset wireless gateway (click RESET button for 5s), and then click "Next" in the figure 4. Automatically search home WiFi as shown in figure 5, input password of home WiFi, and click "Search device" for configuration. The interface with completed configuration is shown in figure 6.

Or click "Manual Add" in the top right corner and then reset the air conditioner according to the prompt. After energization, select the wireless network of control device, confirm home WiFi and then configure the network.

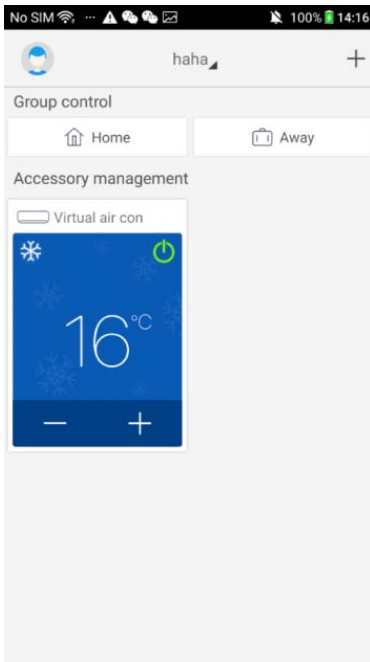

figure 1

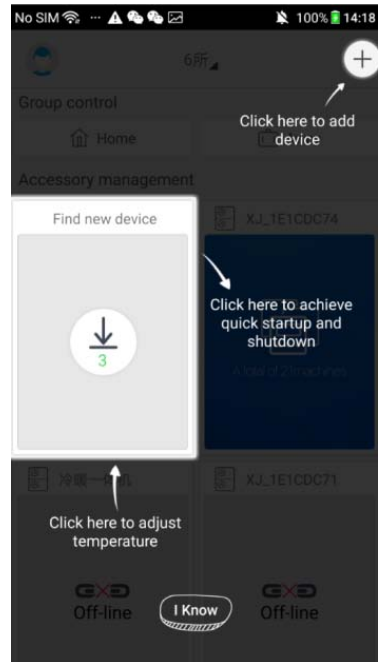

figure 2

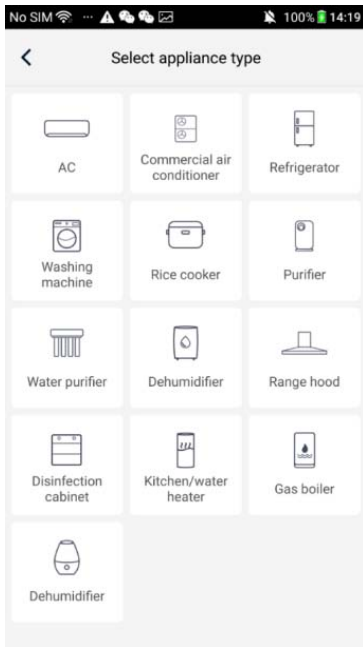

figure 3

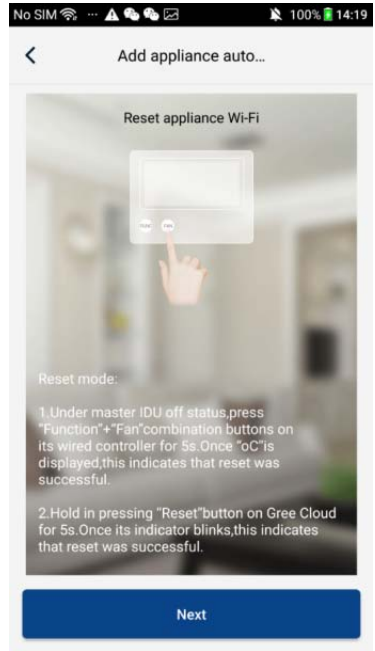

figure 4

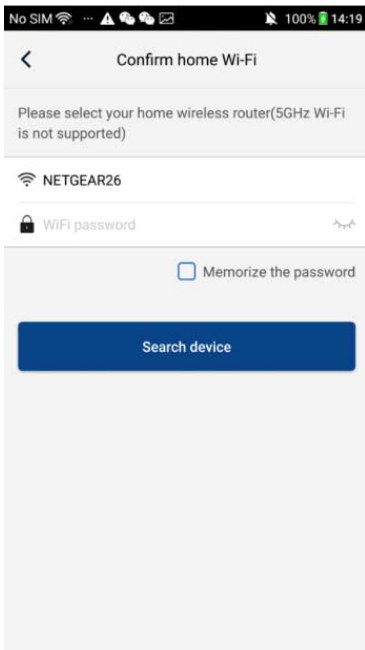

figure 5

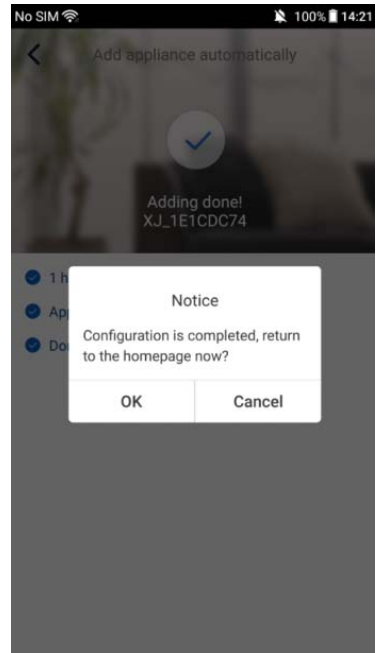

figure 6

When device is added successfully, pull down the device list page on GREE+APP to refresh it and then the added devices will be displayed. If it's not displayed, please check the network and confirm whether the device is added successfully. On the device list page, simple management and control for the device is available. As for configuration method for adding devices, you can also refer to official instruction of GREE+APP <http://www.gree.com/greeplus/index.html?from=timeline>.

## 5 Installation

### 5.1 Product Dimension



### 5.2 Installation Space

The wireless gateway is suggested to be installed at the position where is with good network signal. The front side of gateway faces to outwards and it can also be placed horizontally. The space required is shown by below figure (only for reference).

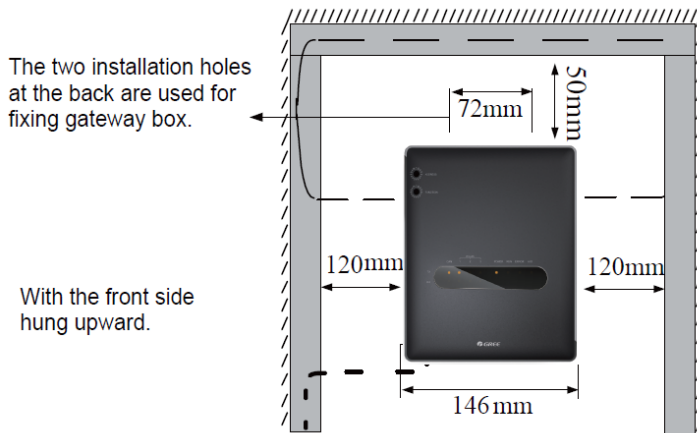

In the figure, slim dotted line is the communication wire and bold dotted line is the heavy current wire. The wiring way in the figure is only for reference.

**⚠ WARNING**

Power cord and communication wireless gateway must be wired separately. Otherwise, it may cause error of wireless gateway.

---

Gree Electric Appliances, Inc. of Zhuhai  
Adresse: West Jinji Rd, Qianshan, Zhuhai, Guangdong, China, 519070

---