

Installation, Operation and Maintenance Manual

Please read and save these instructions. Read carefully before attempting to assemble, install, operate or maintain the product described. Protect yourself and others by observing all safety information. Failure to comply with instructions could result in personal injury and/or property damage! Retain instructions for future reference.



Please record the Serial, Model #, and Mark for the hood and other equipment for future reference.

Serial #:	_____	Model #:	_____	Mark:	_____
Serial #:	_____	Model #:	_____	Mark:	_____
Serial #:	_____	Model #:	_____	Mark:	_____
Serial #:	_____	Model #:	_____	Mark:	_____
Serial #:	_____	Model #:	_____	Mark:	_____
Serial #:	_____	Model #:	_____	Mark:	_____
Serial #:	_____	Model #:	_____	Mark:	_____
Serial #:	_____	Model #:	_____	Mark:	_____
Serial #:	_____	Model #:	_____	Mark:	_____
Serial #:	_____	Model #:	_____	Mark:	_____
Serial #:	_____	Model #:	_____	Mark:	_____

Table of Contents

Receiving and Handling	4
Storage	4
Hood Weights	4
Installation	5
Hood Installation Overview	5
Filler Panels	5
Hood Hanging Height	6
Continuous Capture Plenum	6
Double Island Style Hood	6
U-Channel Strips	6
Electrical Connections	7
Ductwork	7
Installation Instructions for the External Supply Plenums	8 - 9
Installation Instructions for the Back Supply Plenum (BSP)	10
Installing the Supply Duct Collar	10
Hanging the Back Supply Unit	10
Hanging the Hood	11
Air Diffusers	11
Enclosure Panel Installation Instructions	12
End Skirt Installation Instructions	13
Backsplash Panel Installation Instructions	14 - 15
Duct Collar Installation Instructions for GH, GK and GX Series Hoods	16
Exhaust Air Balancing Baffle	17
Balancing the Kitchen Exhaust	18
Baffle Filters (GH Series)	18 - 21
High Velocity Cartridge Filters (GK Series)	22 - 23
High Efficiency Filters (GX Series)	24 - 25
Short Circuit Hoods	26
Fire Suppression Wiring Diagrams	27 - 28
Overall Wiring Plan View	29
Wiring for Hood Switch Panels	30
Circuit Diagram	31

Table of Contents

Maintenance	32
Grease Grabber™ Cleaning and Maintenance	33 - 34
Filter Cleaning Frequency Chart.....	35
Troubleshooting Guide	36 - 37
Replacement Parts	38 - 39
Warranty	40

Receiving and Handling

Upon receiving the equipment, check for both obvious and hidden damage. If damage is found, record all necessary information on the bill of lading and file a claim with the final carrier. Check to be sure that all parts of the shipment, including accessories, are accounted for.

STORAGE

If a kitchen hood must be stored prior to installation it must be protected from dirt and moisture. Indoor storage is recommended. For outdoor storage, cover the hood with a tarp to keep it clean, dry, and protected from UV (Ultra Violet) Radiation damage.

Improper storage which results in damage to the unit will void the warranty.

HOOD MODEL	HOOD DEPTH (MULTIPLY BY LENGTH) FOR HOOD WEIGHT									
	3 ft. .914 m	3.5 ft 1.067 m	4 ft 1.2192 m	4.5 ft 1.3716 m	5 ft 1.524 m	5.5 ft 1.6764 m	6 ft 1.8288 m	6.5 ft 1.9812 m	7 ft 2.1336 m	7.5 ft 2.286 m
GH, GK, GXEW	30 lbs/ft. 44.64 kg/m	32 lbs/ft 47.62 kg/m	35 lbs/ft 52.08 kg/m	38 lbs/ft 56.54 kg/m	40 lbs/ft 59.52 kg/m					
GH, GX, GXDW	36 lbs/ft 53.57 kg/m	38 lbs/ft 56.44 kg/m	41 lbs/ft 61.01 kg/m	44 lbs/ft 65.47 kg/m	46 lbs/ft 68.45 kg/m					
GH, GK, GXFW		40 lbs/ft 59.52 kg/m	44 lbs/ft 65.47 kg/m	48 lbs/ft 71.42 kg/m	52 lbs/ft 77.38 kg/m					
GH, GK, GXCW		48 lbs/ft 71.42 kg/m	51 lbs/ft 71.89 kg/m	54 lbs/ft 81.35 kg/m	57 lbs/ft 84.82 kg/m					
GH, GK, GXSW		44 lbs/ft 65.47 kg/m	48 lbs/ft 71.42 kg/m	52 lbs/ft 77.38 kg/m	56 lbs/ft 83.33 kg/m					
GGEW	39 lbs/ft 58.03 kg/m	41 lbs/ft 61.01 kg/m	44 lbs/ft 65.47 kg/m	47 lbs/ft 69.94 kg/m	49 lbs/ft 72.91 kg/m					
GGDW	45 lbs/ft 66.96 kg/m	47 lbs/ft 69.94 kg/m	50 lbs/ft 74.40 kg/m	53 lbs/ft 78.86 kg/m	55 lbs/ft 81.84 kg/m					
GGFW		49 lbs/ft 72.91 kg/m	53 lbs/ft 78.86 kg/m	57 lbs/ft 84.82 kg/m	61 lbs/ft 90.77 kg/m					
GGCW		57 lbs/ft 84.82 kg/m	60 lbs/ft 89.28 kg/m	63 lbs/ft 93.74 kg/m	66 lbs/ft 98.21 kg/m					
GGSW		53 lbs/ft 78.86 kg/m	57 lbs/ft 84.82 kg/m	61 lbs/ft 90.77 kg/m	65 lbs/ft 96.72 kg/m					
GH, GK, GXEV			52 lbs/ft 77.38 kg/m	54 lbs/ft 81.35 kg/m	56 lbs/ft 83.33 kg/m	58 lbs/ft 86.30 kg/m	61 lbs/ft 90.77 kg/m	63 lbs/ft 93.74 kg/m		
GH, GK, GXFV			61 lbs/ft 90.77 kg/m	66 lbs/ft 98.21 kg/m	68 lbs/ft 101.18 kg/m	72 lbs/ft 107.14 kg/m	75 lbs/ft 111.6 kg/m	79 lbs/ft 117.55 kg/m		
GH, GK, GXCV							81 lbs/ft 120.53 kg/m	84 lbs/ft 124.99 kg/m	87 lbs/ft 129.46 kg/m	90 lbs/ft 133.92 kg/m
GH, GK, GXSV				66 lbs/ft 98.21 kg/m	69 lbs/ft 102.67 kg/m	72 lbs/ft 107.14 kg/m	76 lbs/ft 113.09 kg/m	79 lbs/ft 117.55 kg/m		

Installation

NOTE: If you have a Back Supply Plenum (BSP), this must be installed before the hood. Please see Page 10.

For Wall/Single Island Style Hoods, prior to installation, check with local authorities having jurisdiction on clearances to combustible surfaces, etc.

With the hood still inside its packing crate, position the unit beneath its installation location. Carefully remove the packing crate. Place some protective material on the floor next to

the crate to avoid damaging the hood as it is tipped on its side; Fig. 1. Tip the hood carefully onto the protective material. If you have filler panels, install them now; Fig. 2. If you have integral filler panels, no additional installation is needed.

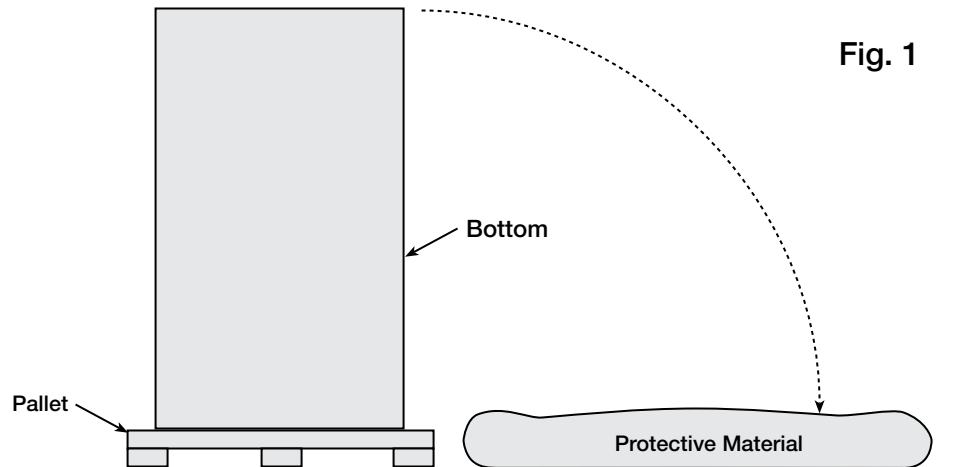

Hood Installation Overview

If a Back Supply Plenum is provided, install first. Before raising hood, insert 1/2 in. (12.7 mm) diameter threaded rod (by others) into hanger brackets on hood top. Check the engineering drawings or UL label located on the inside of the hood for proper hood height above finished floor. Install filler panels if needed. Raise and hang hood from adequate roof or ceiling supports. All hanger brackets must be used and the hood must be properly supported while lifting to prevent damage or distortion to the hood. The hood must be hung level to operate properly. After hood is secured, make the exhaust duct connections. The fire system distributor must be contacted at this time. After the fire system has been installed, mount the enclosures, then the supply plenums. If an Horizontal Supply Plenum is provided, it should be installed before the enclosures. The hood and accessories are now installed. Finally, make the electrical connections from switches to fans and complete the fire system circuits as required by the job specification.

Filler Panel Installation Instructions

1. Uncrate the hood and lay it on the floor with protective material between the hood and the floor. (Fig. 1)
2. Bolt the filler panels together with 5/16 in. bolts provided in the hardware package.
3. Position the filler panels to the hood back, and tack-weld them into place. (Fig. 2)
4. To allow for ease of cleaning, caulk the external seams with NSF Approved silicone caulk (GE SCS1009, or its equivalent). The caulk is not provided.

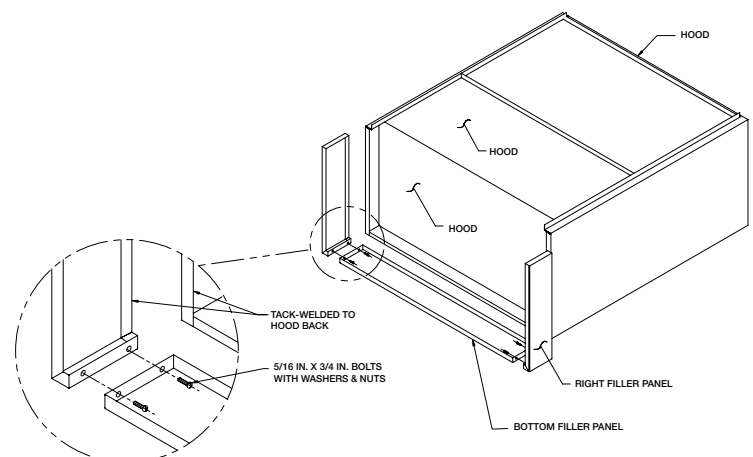

Fig. 2

Hood Hanging Height

The hood hanging height is critical, hanging the hood at the incorrect height may significantly reduce the ability for the hood to function properly and may be in violation of codes. The hood hanging height (typically, 78 in. (198.12 cm) above the finished floor) is given on the UL label located on the inside of the hood on the end panel. The hood must be hung level to operate properly. The grease trough is pitched to drain into the grease container.

Double Island Style Hoods

Before hanging the hoods, please verify the hood marks to make sure the correct hood is hung on the correct side.

A double island hood is created by installing two wall style hoods back to back. Use the installation procedure described on page 5 for single island hoods; install and level both hoods. After leveling, secure the hoods together by tack-welding and/or bolting the rear mounting brackets. Caulk this joint with NSF Approved silicone caulk (GE SCS1009 or its equivalent). The caulk is not provided.

Continuous Capture Plenum Hoods

Remove the support angles on the open end panels. (see Fig. 3) Use the installation procedure described on page 4 for single island hoods; install and level both hoods. After leveling, secure the hoods together by tack-welding and/or bolting the top angles. Fasten the hoods together using u-clips and bolts, (see Fig. 4). Caulk this joint with NSF Approved silicone caulk (GE SCS1009 or its equivalent). The caulk is not provided.

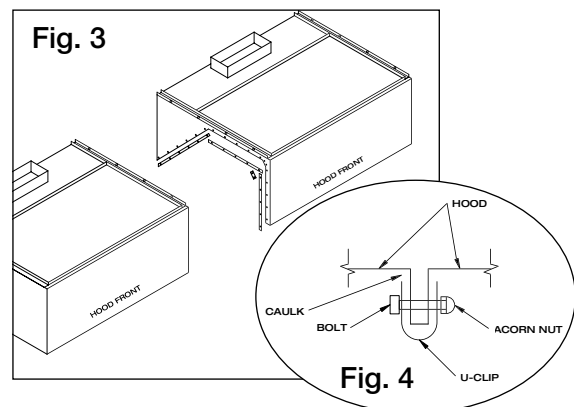

Installing U-Channel Strip

1. After the hood is hung in position and leveled, apply caulk to the inside edge of the double island clip. (Fig. 5)
2. Position and install the clip by tapping into position along clip (friction fit).
3. Caulk edges to seal out grease and allow for ease of cleaning. Caulk with NSF Approved silicone caulk (GE SCS1009 or its equivalent). The caulk is not provided.

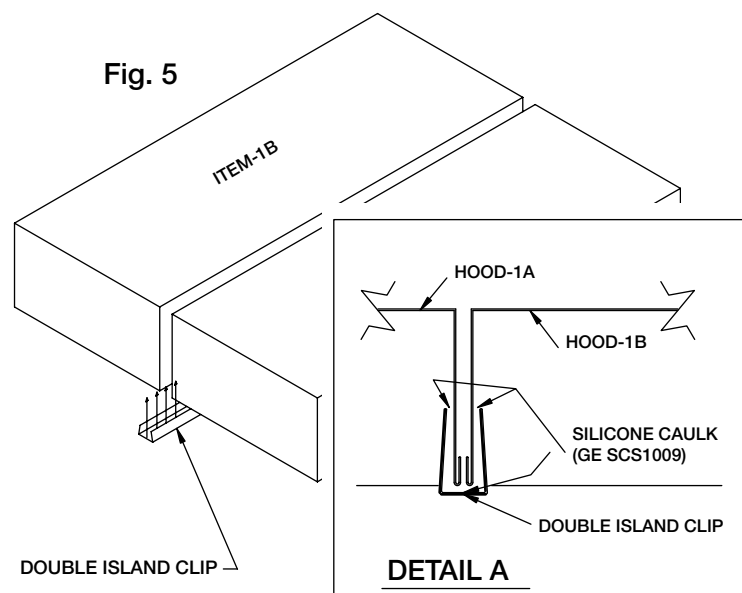

Note: The installation of the canopy hoods shall be in accordance with NFPA 96 (latest edition), Standard for Ventilation Control & Fire Protection of Commercial Cooking Operations.

After the hood is installed, remove all protective plastic.

Note: Greenheck does not recommend walking or standing on the hood top as damage can result. If you must walk on the hood top, protect the hood with additional support or planks for flooring.

Electrical Connections

Access for wiring the hood control panel (when applicable) is provided by a junction box located on top of the hood when the control panel is mounted in the hood, or by the switch junction box when the control panel is mounted in the fire protection cabinet. The box is labeled “Control Voltage Wiring to Roof Top Fan Package”. Use minimum 14 AWG copper wire. After all the wiring is completed, install the light bulbs (light bulbs not provided; standard light bulbs up to 100 watt may be used).

Caution: For multiple hood systems that have more than 14 lights total (incandescent or fluorescent), the hood lights must be wired to multiple circuits. Each circuit must have less than 14 lights total.

Standard Greenheck light switches shipped on hoods are rated for 15 amps and shall not have more than 14 lights connected to them. Higher amperage switches are available upon special request.

Ductwork

Exhaust

As specified in NFPA 96, Ch. 7.5 (latest edition), exhaust duct systems must be constructed in the following manner:

Materials. Ducts shall be constructed of and supported by carbon steel not less than 1.37 mm (0.054 in.) (No. 16 MSG) in thickness or stainless steel not less than 1.09 mm (0.043 in.) (No. 18 MSG) in thickness.

Installation: All seams, joints, penetrations, and duct to hood collar connections shall have a liquid-tight external weld. If you have an Automatic Fire Damper please refer to that manual for installation instructions now.

Supply

Supply ductwork (where applicable) should be connected to the hood in a manner approved by the local code authorities.

Note: For hoods with fire dampers in the exhaust and supply duct collars, an access panel for cleaning and inspection shall be provided in the duct. This panel shall be as close to the hood as possible but should not exceed 18 in. (45.72 cm).

For proper installation of duct collars when they are shipped unattached, see page 16.

Installing External Supply Plenums

Fig. 6

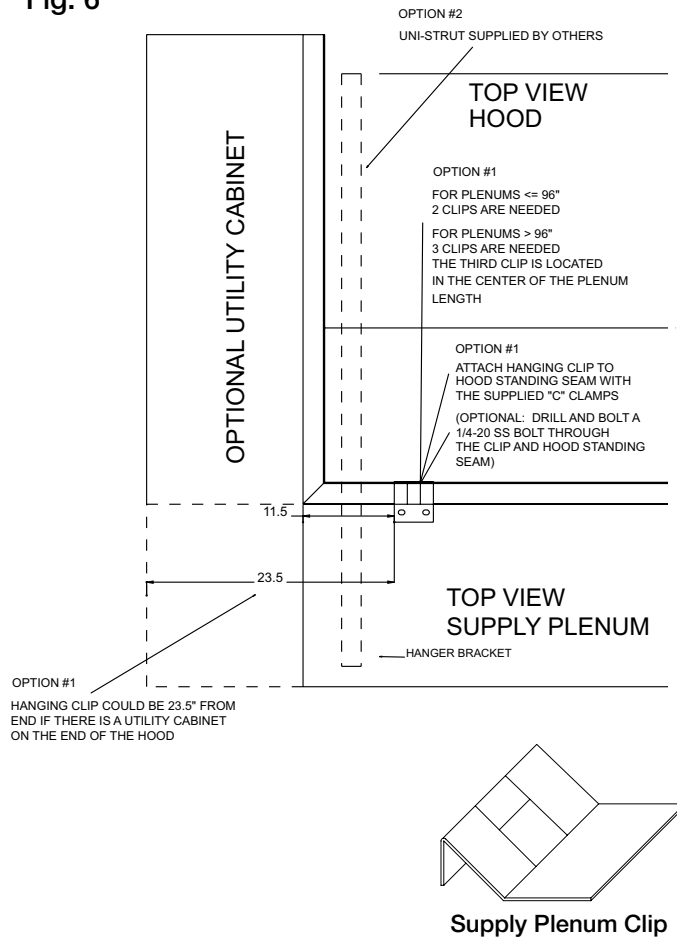

Using the Supply Plenum Clip

Note: The supply plenum is provided with plenum clips that assist in hanging the plenum. The plenum should not be hung only with the plenum clips, threaded rod or uni-strut must also be used.

1. Bolt the hanging clip to the supply plenum. Two clips are needed for plenums less than 96 in. (243.84 cm) long and three for plenums greater than 96 in. (243.84 cm). The third clip is located in the center of the plenum length. If there is a utility cabinet, the hanging clip should be 23.5 in. (59.69 cm) from the end to the hood.
2. Using the c-clamps provided, clamp the supply plenum hanging clip to the hood standing seam. Option: Drill and bolt a 1/4-20 SS bolt through the clip and hood standing seam.

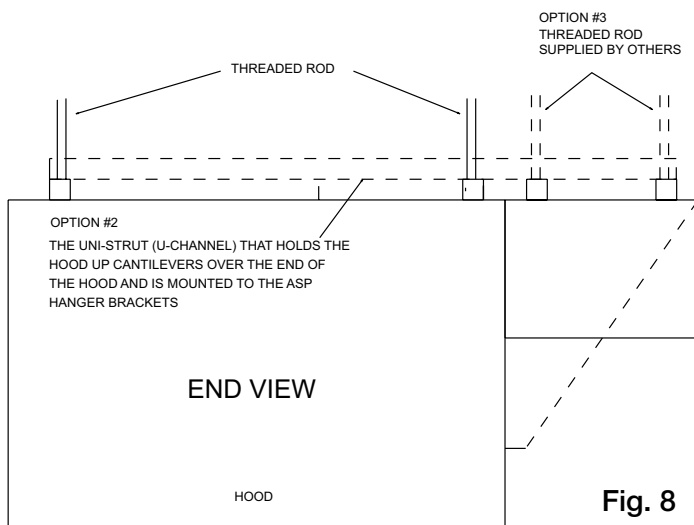
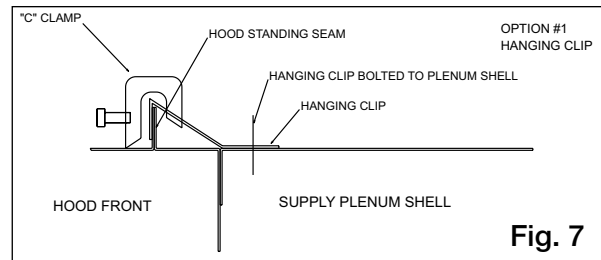

Using the Uni-strut

1. The uni-strut (supplied by others) that holds the hood up cantilevers over the end of the hood and is mounted to the supply plenum hanger brackets.

Fig. 9

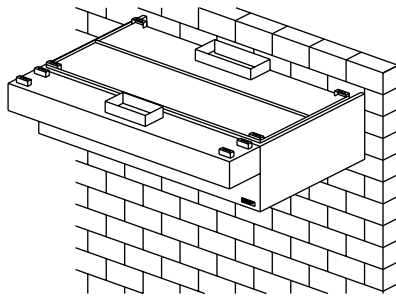

ASP - Air Curtain Supply Plenum

Fig. 10

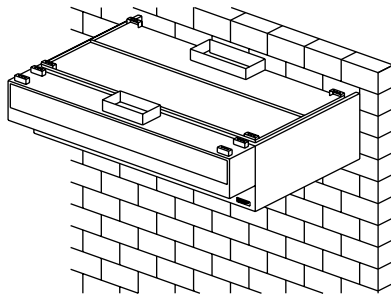

HSP or VSP - Variable Supply Plenum

1. Insert 1/2 in. (12.7 mm) diameter threaded rod (by others) into hanger brackets on the supply plenum top. Raise and hang the external supply plenum from adequate roof or ceiling supports.
2. The external supply plenum should be resting lightly against the hood. The hood is used to position the plenum only, it is *not* intended to support the plenum. All hanger brackets must be used and the plenum must be properly supported while lifting to prevent damage or distortion. The supply plenum must be hung level to operate properly.

(Optional fastening of supply plenum to hood. See directions below).

3. It is recommended that caulk be applied at the mating seams and surfaces of the plenum, the hood, and the wall. If the supply plenum is next to a wall, you will also need to caulk around the surface next to the wall. Caulk the joints with NSF Approved silicone caulk (GE SCS1009, or its equivalent). The caulk is not provided.

Installing the Supply Duct Collar to the Plenum

1. Place the duct collar(s) over the opening, fastening with tack-welds at 1 to 2 in. (2.54 to 5.08 cm) intervals, or sheet metal screws at 3 to 6 in. (7.62 to 15.24 cm) intervals.

External Supply Plenum Weights, Dimensions, and Supply Rates

External Supply Plenum Type	Weight		Width		Height		Length per section		Recommended Supply Rate	
	(lbs/ft)	(kg/ft)	(in)	(mm)	(in)	(mm)	(ft)	(m)		
Back Supply	35.0	15.878	6	152.4	Variable	Variable	3 to 16	.91 to 4.88	145 cfm/ft (246.36 m ³ /hr)	
Air Curtain Supply • 14 inch	9.5	4.31	14	355.6	10	254	3 to 16	.91 to 4.88	110 cfm/ft (186.89 m ³ /hr)	
Air Curtain Supply • 24 inch	12.5	5.67	24	609.6	10	254	3 to 16	.91 to 4.88	145 cfm/ft (246.36 m ³ /hr)	
Variable Supply	16.0	7.26	12	304.8	18	457.20	3 to 16	.91 to 4.88	curtain	0-80 cfm/ft (0-135.92 m ³ /hr)
									face	80-160 cfm/ft (135.92 -271.84 m ³ /hr)
Horizontal Supply	14.0	6.35	12	304.8	18	457.20	3 to 16	.91 to 4.88	150 cfm/ft (254.85 m ³ /hr)	

Using the UL Listed Fastener Provided

1. Drill a 9/32 in. hole for the 1/4 in. bolt from the inside of the supply plenum to inside the hood. Fasteners are to be located max. 6 in. (15.24 cm) from the end of the hood with max. spacing between bolts 36 in. (91.44 cm)

DO NOT INCLUDE UTILITY CABINETS OR FILLERS WHEN FIGURING BOLT PLACEMENT.

DO NOT BOLT THE SUPPLY PLENUM TO A FIRE/UTILITY CABINET.

2. Push bolt through hole, attach the washer and nut.
3. Hand tighten, then use a wrench until fully tightened. Caulk around bolts from inside of hood as necessary.

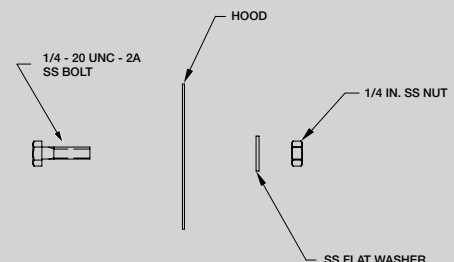
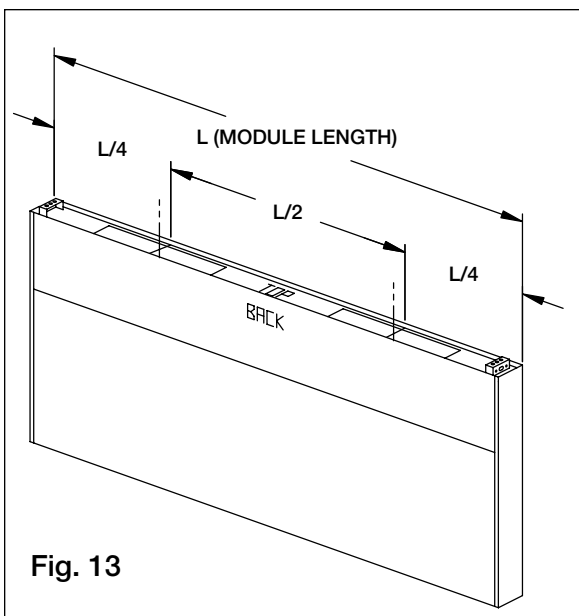

Fig. 11

Installing the Back Supply Plenum

Installing the Supply Duct Collar

1. Find the center of the back supply plenum.
2. If the back supply plenum is less than 9 ft. 10 in. (299.72 cm) long, cut opening at the suggested location, centering the opening over the center of the back supply plenum. (Fig. 12)
3. If the back supply plenum is greater than 9 ft. 10 in. (299.72 cm) long, divide the length of the back supply by four. This will give you the center of each half. Cut openings at the suggested location, centering the duct collar over the center measurement of each half. (Fig. 13)
4. Place the duct collar(s) over the opening, fastening with screws or tack-welds every 4 to 6 in. (10.16 to 15.24 cm). (Fig. 14)



- The 4 in. (10.16 cm) high duct collar is to be attached to the back supply.

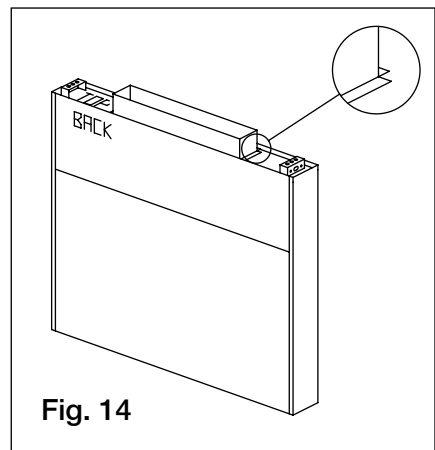
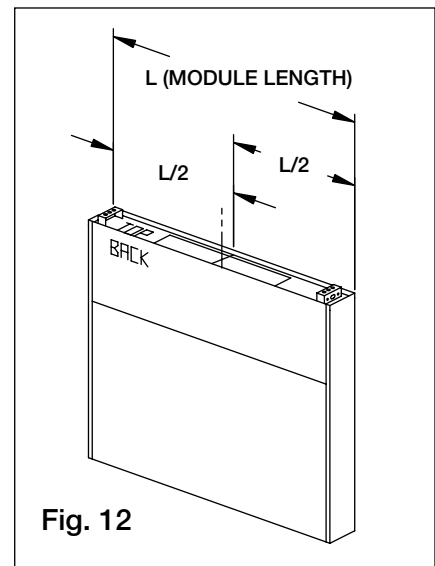

Hanging the Back Supply Plenum

5. Hang the back supply plenum from the ceiling.

(The back supply plenum needs to be mounted 31.25 in. (79.375 cm) above the floor (based upon a canopy hood that will be hung at 78 in. (198.12 cm) above the finished floor. This is measured from the lowest rear edge of the back supply plenum to the finished floor. Leave 6 to 10 in. (15.24 to 25.4 cm) of space below the plenum for access to the air diffusers.)

6. Fasten the Back Supply to the wall, going through the lower Back Supply wall. (Fig. 15)
 - These fasteners are to help maintain the location of the Back Supply, and are not intended to hold the weight of the Back Supply Unit.
 - The fasteners should not interfere with the removable air diffusers.
 - The 31.25 in. (79.375 cm) height is based upon the canopy hood hanging height of 78 in. (198.12 cm) from the finished floor to the bottom of the hood.

Hanging the Hood

Before hanging the hood according to the hood installation instructions, please check the following:

1. Make sure the back supply plenum is properly secured, as described in steps 5 and 6, page 10.
2. If the ductwork for the back supply will not interfere with the hood installation, it should be connected now.
3. Any filler panels should be attached to the hood before the hood installation. See page 5 for instructions.
4. Lift the hood, and position it so the filler panels are resting lightly on the top outside edges of the back supply. The back supply is used to position the hood only, it is not intended to hold any hood weight. (Fig. 16)
5. Connect the remaining ductwork for the back supply and the hood. It is recommended that caulk be applied at the mating seams and surfaces of the back supply, the hood, and the wall.

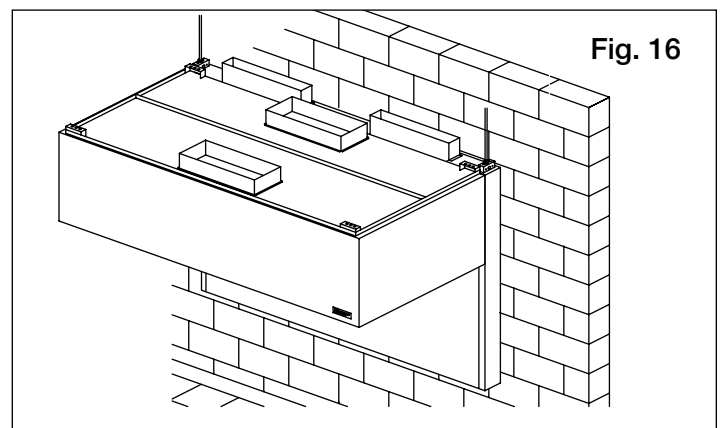
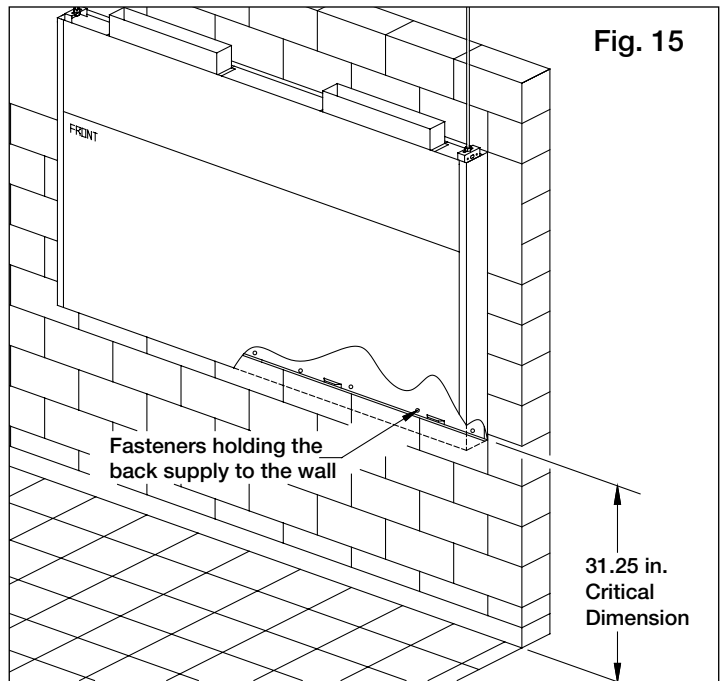

Air Diffusers

The air diffusers, located at the bottom of the back supply (Fig. 17), will need to be cleaned as often as the application dictates. Inspect periodically to determine the cleaning schedule.

1. To clean the air diffusers, unfasten the screws. Remove the air diffusers from the Back Supply Unit, and wash in the sink or dishwasher.
2. Insert the air diffusers at an angle from the bottom, and rotate so the forms are downward. Rest the diffuser on the internal angles. (Fig. 18)
3. Refasten with the stainless steel screws.

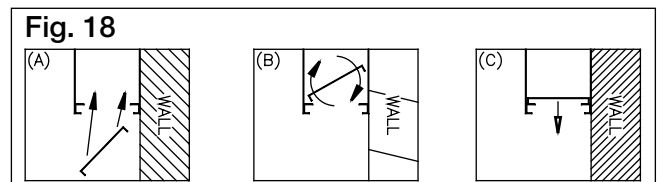
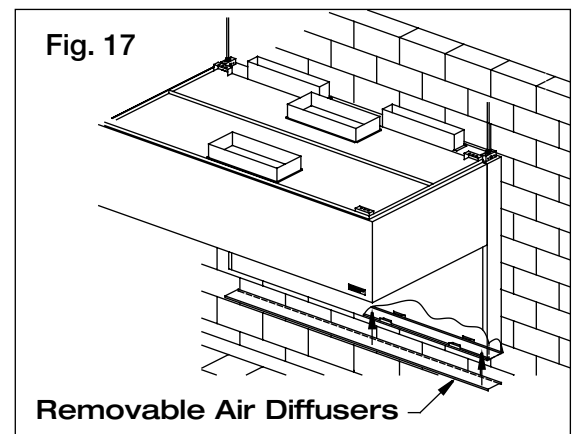

Installing Enclosure Panels

Before installing the enclosure panels, make sure the hood is hung in position with all the ductwork attached and electrical connections completed.

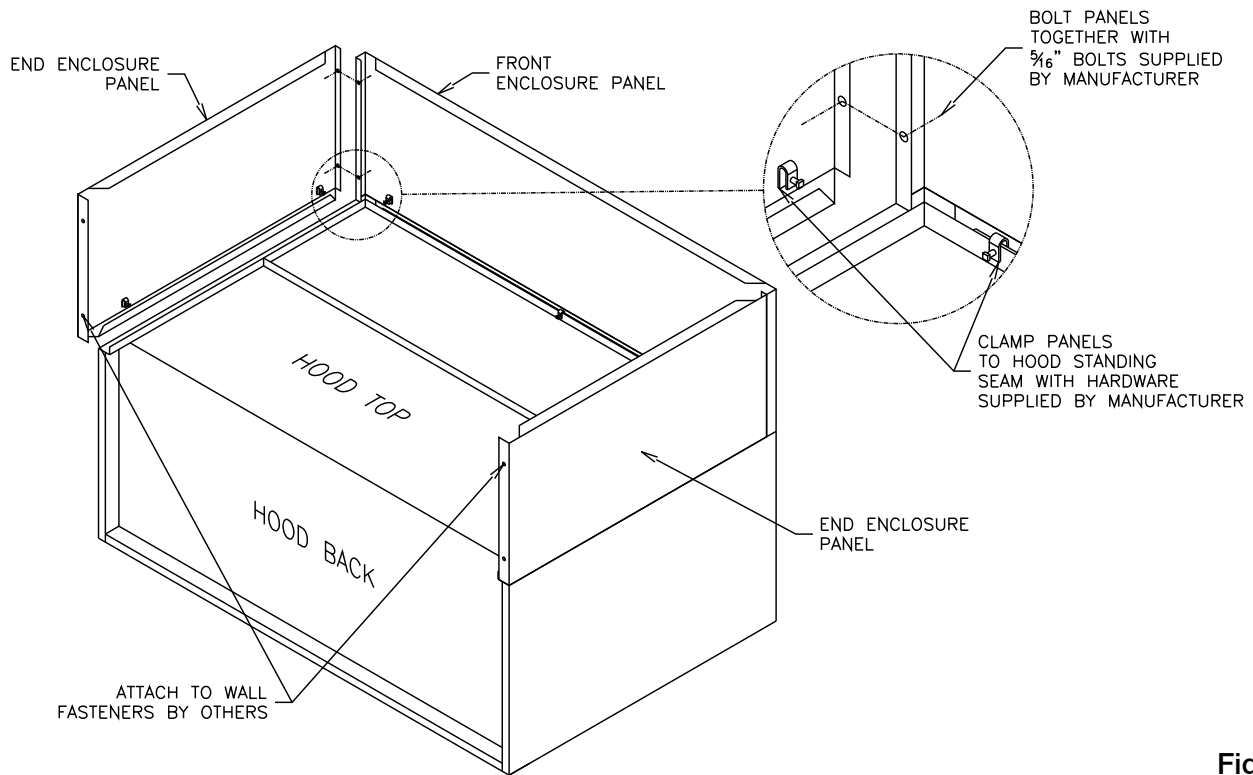

Fig. 19

1. Position the end enclosure panels on the hood, and clamp into place with clamps provided or tack-weld the panels into place (Fig 19).
2. Fasten the end enclosure panels to the wall, method depends on wall construction. (fasteners are not provided)
If the hood is a double island, bolt the end enclosure panels together. (fasteners are not provided)
3. Position the front enclosure panel(s) on the hood, and bolt to the end enclosure panels with the 5/16 in. bolts provided in the hardware package.
4. Tack-weld or clamp the front enclosure panel(s) to the hood. If clamps are used, they must be positioned 4 in. (100 mm) from the ends, and in the center of the front enclosure panel.
5. To allow for ease of cleaning, caulk the external seams with NSF Approved silicone caulk (GE SCS1009, or its equivalent). The caulk is not provided.
6. Installation instructions may not be applicable for concrete ceilings.

Installing End Skirts

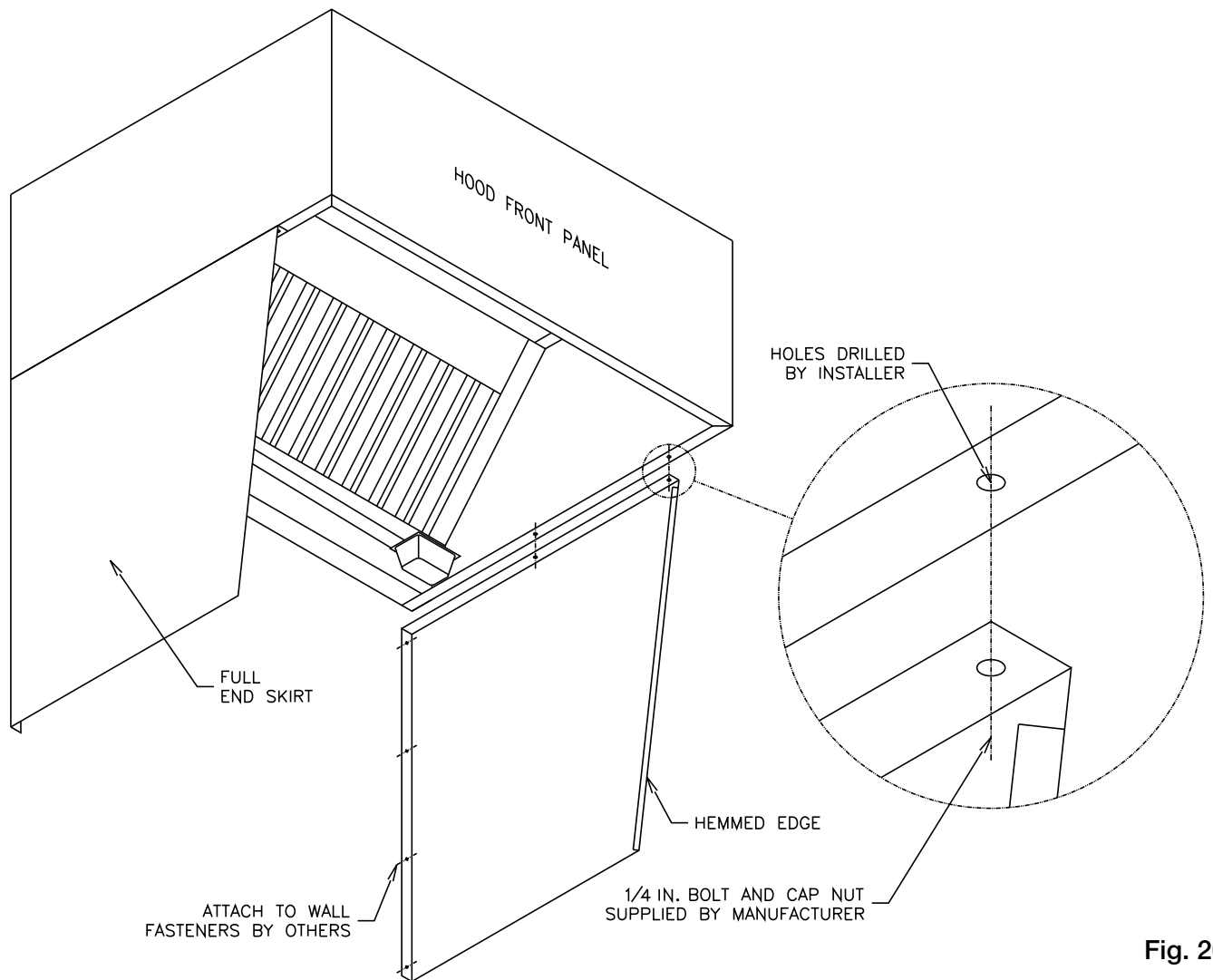

Fig. 20

1. After the hood is hung in position, slide the hemmed form on top of the end skirt onto the end panels of the hood.
2. Drill a hole in the hood end panel to line up with the hole in the end skirt. Attach the end skirt with a 1/4 in. bolt and cap nut to the inside of the hood, or tack-weld the end skirt to the hood.
3. Position the end skirt against the wall and attach. The method depends on the wall construction. (fasteners for this are not provided)
4. Caulk the internal joint formed by the end skirt and the hood end panel with NSF Approved silicone caulk (GE SCS1009 or its equivalent). The caulk is not provided.
5. To allow for ease in cleaning, also caulk all the external seams.

FLAT BACKSPLASH PANEL

MATERIAL GAUGE – STAINLESS

LENGTH		QTY
Inches	Millimeters	
<= 48	<= 1219.2	1
>48<=94	>1219.2<=2387.6	2
>94<=141	>2387.6<=3561.4	3
>141<=188	>3561.4<=4775.2	4
>188<=235	>4775.2<=5969	5

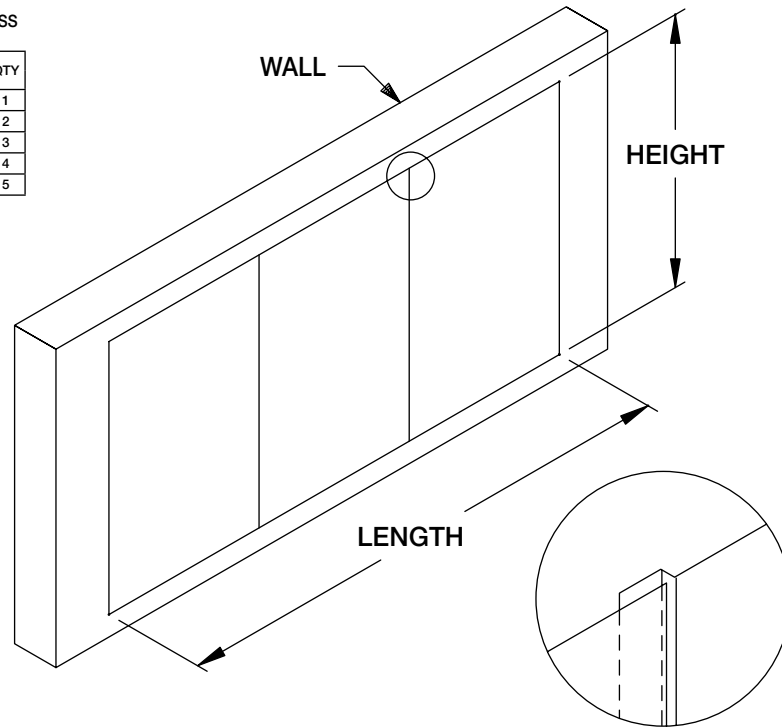

NOTE: PANELS UP TO 48 IN. (1219.2 MM) WIDE SHIP IN ONE PIECE; OVER 48 IN. (1219.2 MM) IN MULTIPLE PIECES.

Fig. 21

INSULATED BACKSPLASH PANEL

MATERIAL GAUGE – STAINLESS
INSULATION – 1 IN. (25.4 MM)

LENGTH		QTY
Inches	Millimeters	
<= 46	<= 1168.4	1
>46<=91	>1168.4<=2311.4	2
>91<=136	>2311.4<=3454.4	3
>136<=181	>3454.4<=4597.4	4
>181<=226	>4597.4<=5740.4	5

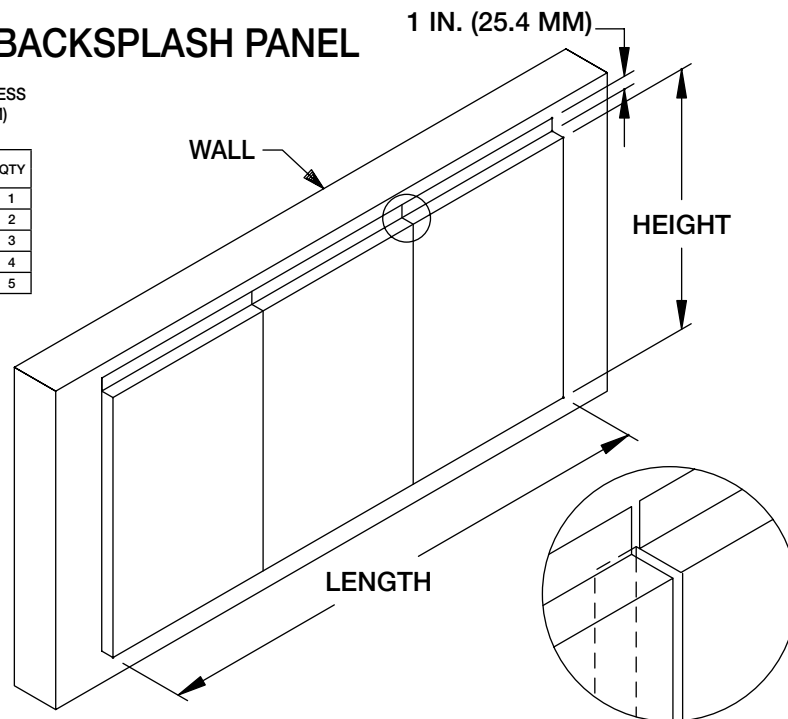

NOTE: PANELS UP TO 46 IN. (1168.4 MM) WIDE SHIP IN ONE PIECE; OVER 46 IN. (1168.4 MM) IN MULTIPLE PIECES.

Fig. 22

Installing Backsplash Panels

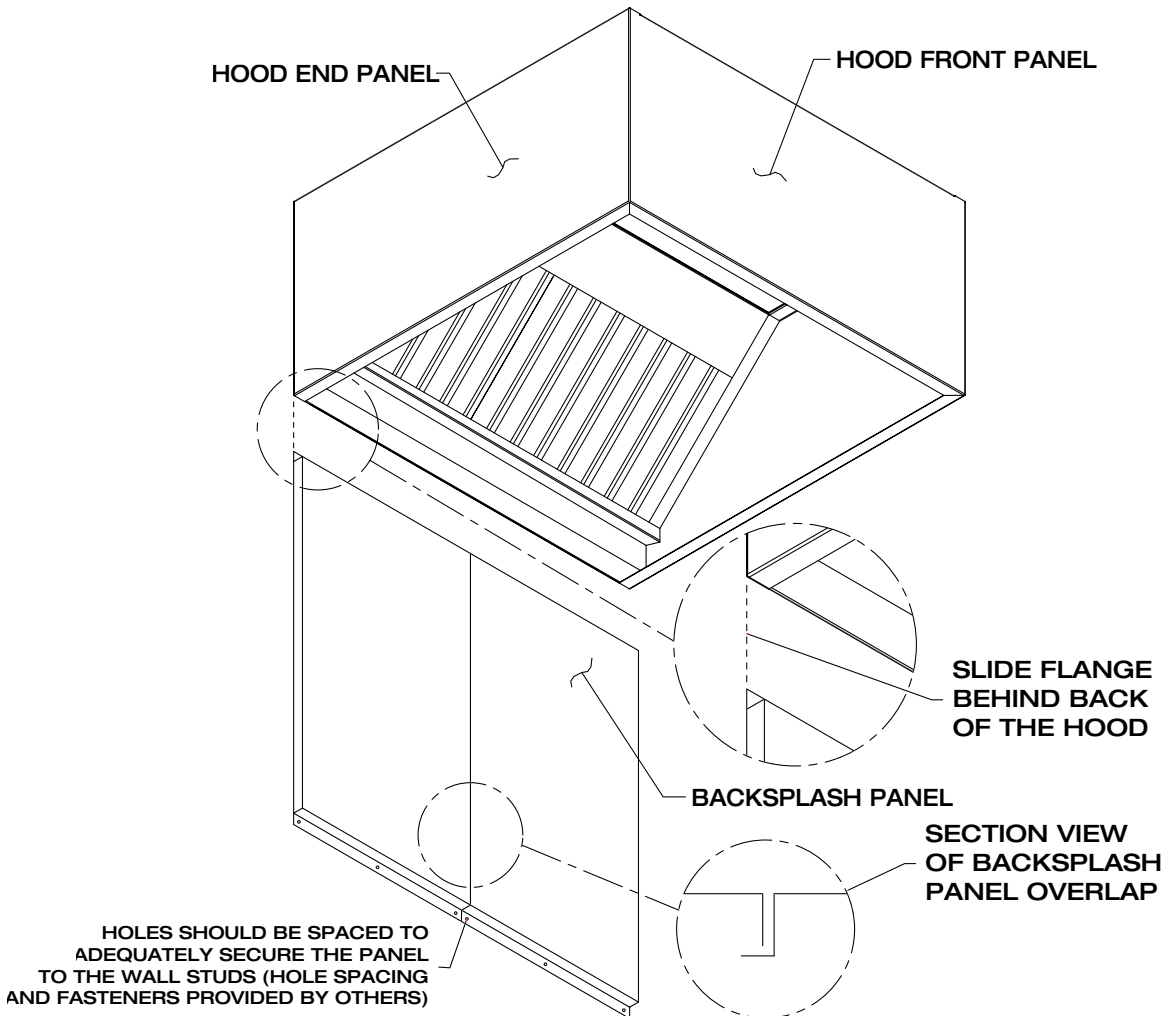

Fig. 23

1. After the hood is hung in position, slide the flat flange of the backsplash panel behind the back of the hood.

Note: If the backsplash panel length is greater than 46 in. (116.84 cm), it will be shipped in multiple pieces.

2. After the backsplash panel has been positioned, drill holes in the panel and fasten to the wall. (fasteners provided by others).

Note: The holes should be spaced to adequately secure the panel to the wall.

3. Caulk the joints between the hood and the backsplash panel with NSF Approved silicone caulk (GE SCS1009, or its equivalent). The caulk is not provided.
4. Caulk the joint between the backsplash panels when multiple panels are required, with NSF Approved silicone caulk (GE SCS1009, or its equivalent). The caulk is not provided.

Installing Duct Collars

1. The exhaust duct connection needs to be located within 48 in. (121.92 cm) from the center of the hood length to the center of the duct connection. (see Fig. 24, back view Fig. 25)

2. The exhaust duct connection is to be a continuous liquid-tight weld. **Weld with a non-ferrous filler wire, such as silicon bronze or stainless steel filler wire. Protect all stainless steel areas from weld splatter.**

3. The supply duct connection is tack-welded at 1 to 2 in. (2.54 to 5.08 cm) intervals, or sheet metal screws at 3 to 6 in. (7.62 cm to 15.24 cm) spacing to the hood. (Fig. 26)

4. The deflector is centered under the supply duct collar. (Fig. 28)

5. For hoods that are insulated, the edges of the insulation need to be taped after the hole is cut, (the insulation tape is to be provided by others).

6. On combination hoods, make sure the fire damper is located over the internal supply chamber. (Fig. 29)

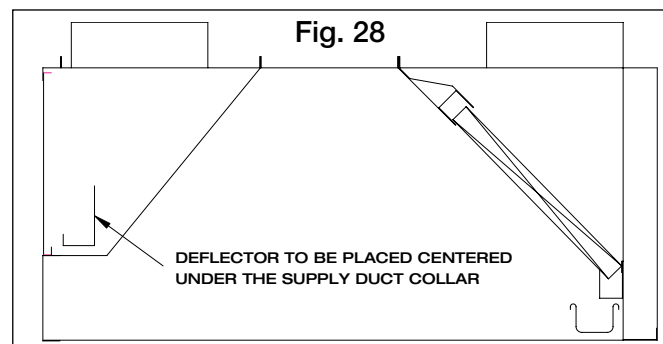
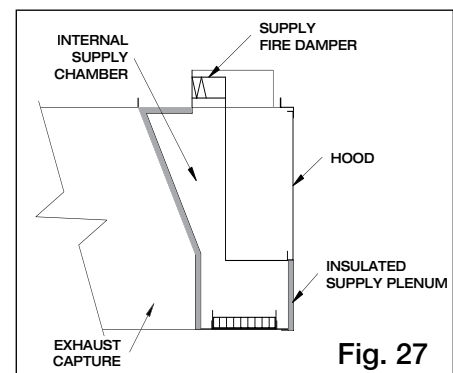
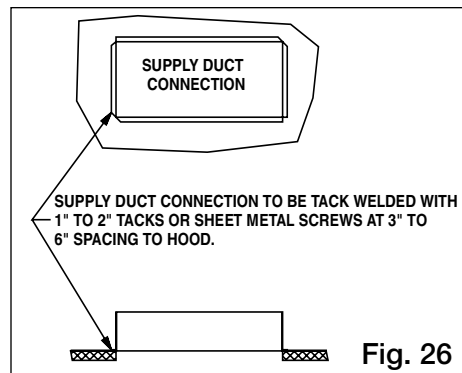
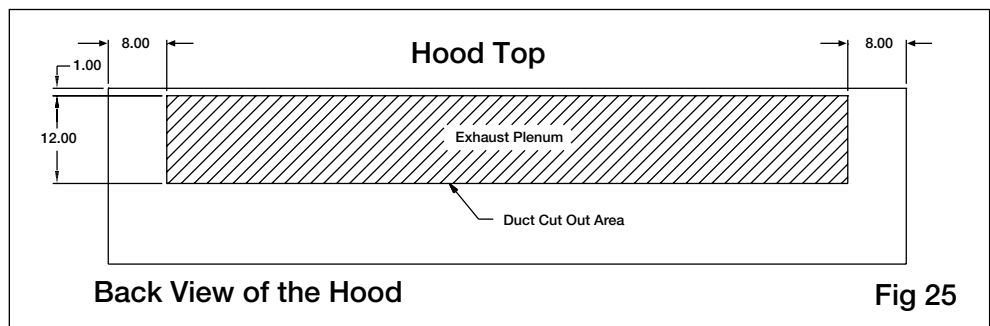
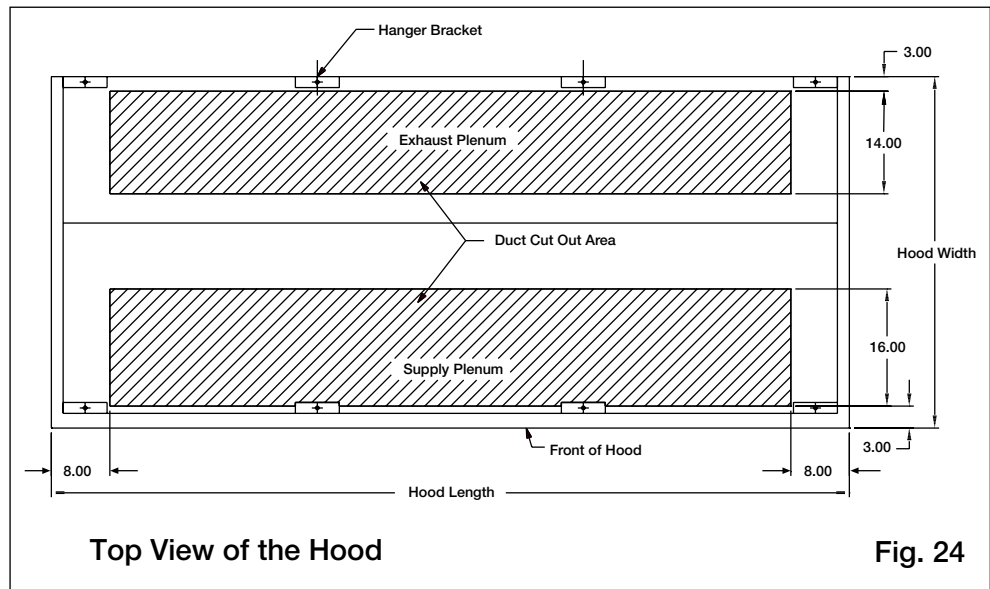

Note: UL listed hood assembly to be used only with Greenheck Fan Corp. labeled subassembly for exhaust hood without exhaust damper part Number DC.

Exhaust Air Balancing Baffles (EABB)

This is a guide to assist in determining if multiple hoods on one fan can be balanced to have equal static pressure. For multiple hoods on one fan to achieve their designed exhaust flow, all of the hoods must have equal static pressure at their designed exhaust flow.

The laws of physics force the static pressure for each branch of a duct system on one fan to always be equal. This will happen by the flow rate increasing in low static branches and decreasing in high static branches until the static pressure is equal in all branches.

Checking for Balance

Every hood with Exhaust Air Balancing Baffles (EABB) has a range for its static pressure. The low number in this range is given by the standard calculation for hood static. (Static that is printed with the CAPS submittal). The maximum increase above the low number can be calculated from the duct velocity at the low static, (also given on CAPS submittal). This is then added to the low number to get the highest static pressure possible with an EABB.

The maximum potential increase in static is given in the graph, or can be calculated from:

$$\text{Max. Increase} = 0.0000036 \times (\text{Duct velocity})^2$$

After the range for each hood is calculated, it should be compared to the hood with the highest static pressure. If the highest hood falls inside of the range, then the hoods can be balanced with the EABB. If it is higher than the range, the hoods cannot be balanced.

Example 1:

Hood 1: $P_s = 0.58$ in. wg
 Duct Velocity = 1900 FPM

Hood 2: $P_s = 0.44$ in. wg
 Duct Velocity = 1800 FPM

Hood 2 has the lower P_s , at 1800 FPM the maximum increase in P_s is 1.17. The range for Hood 2 is 0.44 to 1.61. Hood 1 is less than 1.61 so these hoods can be balanced.

Example 2:

Hood 3: $P_s = 2.00$ in. wg
 Duct Velocity = 2000 FPM

Hood 4: $P_s = 0.44$ in. wg
 Duct Velocity = 1500 FPM

Hood 4 has the lower P_s , at 1500 FPM the maximum increase in P_s is .81. The range for Hood 4 is 0.44 to 1.25. Hood 3 is higher than 1.25 so these hoods cannot be balanced.

Note 1: For many systems, an EABB may not be needed on the hood that has the highest static pressure. The exception to this is if the individual ductwork has uneven static pressures.

Note 2: When sizing the fan, use the static pressure from the highest hood and sum the CFM from all the hoods.

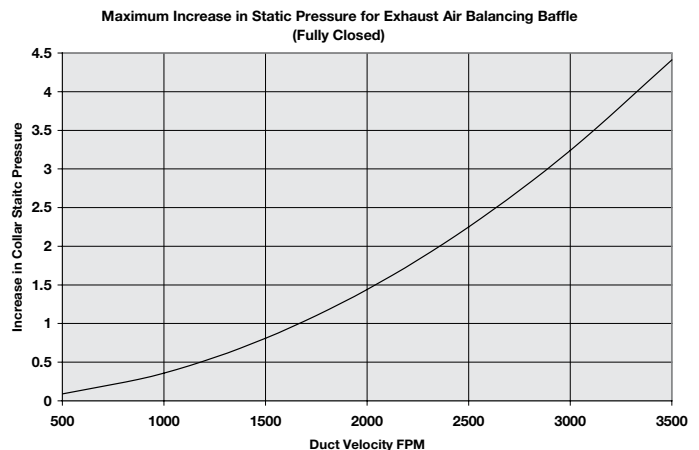

Balancing the Kitchen Exhaust System

A. To determine the proper dining room air balance:

1. Refer to engineering drawings to determine total exhaust CFM from dining areas. (Exhaust fans, heating and air conditioning units, restrooms, etc.)
2. Determine the total CFM of make-up air supplied to dining area.
3. Subtract #1 from #2 above. If the result is a negative number, a negative pressure is present in the dining area. In this case, kitchen exhaust odors could be drawn from the kitchen to the dining area. Therefore, exhaust or supply air should be adjusted to provide a slight positive pressure in the dining area.

B. To determine proper kitchen air balance:

1. Refer to engineering drawings to determine total exhaust from the kitchen area. (Exhaust hoods, dishwasher hoods, etc.)
2. Determine total CFM of make-up air supplied to kitchen area. (Make-up air hoods, heating and air conditioning units, etc.)
3. Subtract #1 from #2 above. The result should be a negative number. If the result is a positive number, a positive pressure is present in the kitchen area. Kitchen odors could be forced into the dining area. Also, a positively balanced kitchen area can adversely affect the performance of the exhaust hood.

Caution: According to NFPA 96, Ch. 8-3 Replacement Air: Replacement air quantity shall be adequate to prevent negative pressures in the commercial cooking area(s) from exceeding 4.98 kPa (0.02 in. water column).

Testing Hood Air Volume

Baffle Filter Style Hoods

A. Exhaust:

With all the filters in place, determine the total hood exhaust volume with a rotating vane anemometer as follows:

1. All cooking equipment should be on.
2. Measure the velocities

Velocity measurements should be taken at five locations per filter. These must be over a filter slot as in Fig. 29.

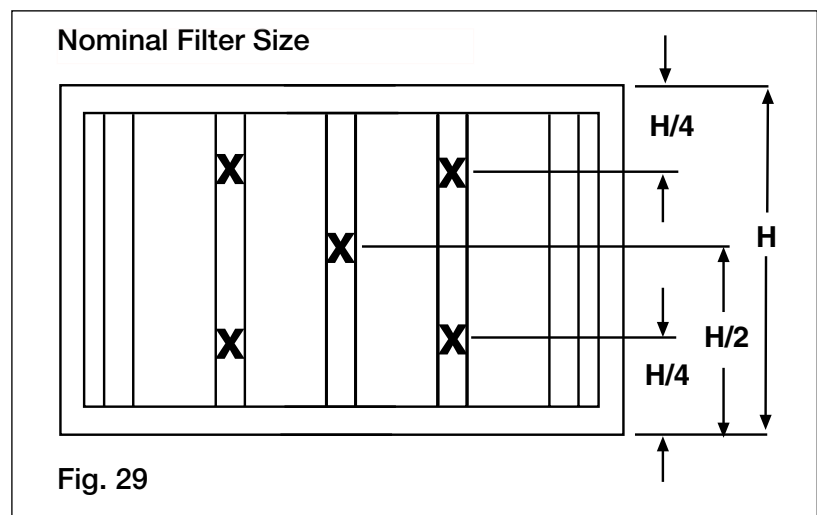

Measure the velocity of each location.

A digital 2.75 in. (70 mm) rotating vane anemometer or equivalent is suggested. The center of the anemometer should be held 2 in. (50 mm) from the face of the filters as shown in Fig. 30. It is helpful to make a bracket to keep the anemometer at the 2 in. (50 mm) distance and parallel to the filter. Both squareness and distance are very important for accuracy.

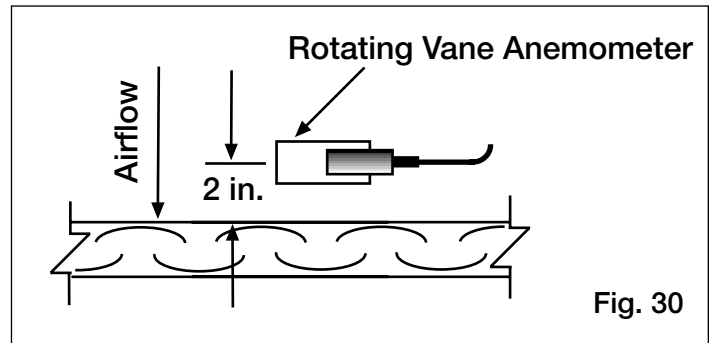

Fig. 30

Calculate the average velocity for the filter.

3. Determine the filter's conversion factor from the table.
4. Calculate the filter's volume in CFM (m³/hr) by multiplying the average velocity by the conversion factor.
5. Calculate the hood's volume by repeating the process for the remaining filters and summing the individual filter volumes.

Nominal Filter Size (H x L)		Imperial Conversion Factor	Metric Conversion Factor
Inches	Millimeters		
16 x 16	400 x 400	1.63	.157
16 x 20	500 x 400	2.13	.198
20 x 16	400 x 500	1.90	.177
20 x 20	500 x 500	2.48	.230

Example: Exhaust Only Hood with three 20 x 16 Filters

Measured velocities in fpm for one 20 x 16 Filter

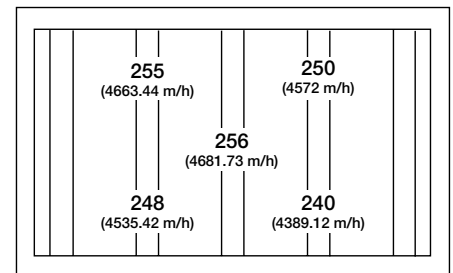

$$\text{Average Velocity} = \frac{\text{Sum of Velocity Readings}}{\text{Number of Readings}}$$

(Imperial) = $\frac{255 + 250 + 256 + 248 + 240}{5} = 249.8 \text{ fpm}$

(Metric) = $\frac{4663 + 4572 + 4681 + 4535 + 4389}{5} = 4568 \text{ m/hr}$

For a nominal filter size of 20 x 16, the conversion factor is 1.90 Imperial (.177 Metric)

$$\begin{aligned} \text{Volume for one filter} &= \text{Conversion Factor} \times \text{Average Velocity} \\ &= 1.90 \times 249.8 \text{ fpm} = \underline{474.6 \text{ cfm}} \\ &= .177 \times 4568 \text{ m/hr} = \underline{809 \text{ m}^3/\text{hr}} \end{aligned}$$

$$\begin{aligned} \text{Total hood volume} &= (\text{Filter 1 Volume}) + (\text{Filter 2 Volume}) + (\text{Filter 3 Volume}) \\ &= 474.6 + 455.4 + 470.1 = \underline{1400.1 \text{ cfm}} \\ &= 809 + 880 + 799 = \underline{2488 \text{ m}^3/\text{hr}} \end{aligned}$$

B. Supply (If Applicable):

Example for Perforated Face Supply

1. Hood set up

If the make-up air unit has a temperature control, it should be used to keep the supply air at the desired room discharge air temperature.

2. Measure Velocities

Divide the perforated face panel into a grid of equal areas, each approximately 4 in. (100 mm) square.

Measure the velocity at the center of each grid area. A digital 2.75 in. (70 mm) rotating vane anemometer or equivalent is suggested. The center of the anemometer should be held tight to the face of the panel, and parallel to the filter. Both squareness and distance are important for accuracy. Calculate the average velocity of the panel.

3. Measure the length, height, and width of the perforated face panel.

4. Calculate the perforated face panel volume in CFM by using the following formula:

$$\text{Volume} = \text{Avg. Velocity} * \text{Length (in.)} * \text{Height (in.)} * 0.005$$

$$\text{Volume} = \text{Avg. Velocity} * \text{Length (m)} * \text{Height (m)} * 0.72$$

5. Calculate the system's volume by repeating the process for the remaining panels and adding the individual panel volumes together.

Filter Readings (fpm)						
260	250	255	260	250	255	265
270	275	270	280	265	265	270
290	285	280	280	275	290	295
285	275	280	260	270	265	260

Filter Readings (m/hr)						
4755	4572	4663	4755	4572	4663	4846
4938	5029	4938	5121	4846	4846	4938
5304	5212	5121	5121	5029	5304	5395
5212	5029	5121	4755	4938	4846	4755

Example: Face Supply Hood with three 28 in. (.711 m) Perforated Panels

Measured velocities in FPM for one perforated panel

$$\text{Average Velocity} = \frac{\text{Sum of Velocity Readings}}{\text{Number of Readings}}$$

$$\text{(Imperial)} = \frac{260 + 250 + \dots + 265 + 260}{28} = \underline{270.7 \text{ fpm}}$$

$$\text{(Metric)} = \frac{4755 + 4572 + \dots + 4846 + 4755}{28} = \underline{4951 \text{ m/hr}}$$

Measure Length and Height = 28 in. (.711 m) long perforated panels x 16 in. (.406 m) high

$$\begin{aligned} \text{Volume for one panel} &= \text{Conversion Factor} \times \text{Average Velocity} \times \text{Length} \times \text{Height} \\ &= 0.005 \times 270.7 \text{ fpm} \times 28 \times 16 = \underline{606.4 \text{ cfm}} \\ &= 0.72 \times 4951 \text{ m/hr} \times .711 \times .406 = \underline{1029 \text{ m}^3/\text{hr}} \end{aligned}$$

$$\begin{aligned} \text{Total system volume} &= (\text{Panel 1 Volume}) + (\text{Panel 2 Volume}) + (\text{Panel 3 Volume}) \\ &= 606.4 + 614.3 + 593.8 = \underline{1814.5 \text{ cfm}} \\ &= 1029 + 1044 + 1009 = \underline{3082 \text{ m}^3/\text{hr}} \end{aligned}$$

Testing Hood Air Volume

Baffle Filters Style Hoods with the Shortridge Meter

A. Exhaust

With all the filters in place, determine the total hood exhaust volume with a Shortridge meter as follows:

- All cooking equipment should be on. If the hood has internal short circuit make-up air, it should be turned off.
- Measuring Velocities
 - Set up the Shortridge meter.
 - For 20 in. (500 mm) wide filters, position the grid as shown in Fig. 32 and 33. Average two measurements.
 - For 16 in. (400 mm) wide filters position the grid as shown in Fig. 34.
 - Take velocity readings for each filter.
- *Calculate each filter's volumetric flow rate by summing the flow rate of each individual filter in the hood.
- *Calculate the total hood's volumetric flow rate by summing the flow rate of each individual filter in the hood.

**Note: For best accuracy multiply the velocity of each filter by its conversion factor and sum the flow rates. Averaging the velocity measured for all filters may cause error.*

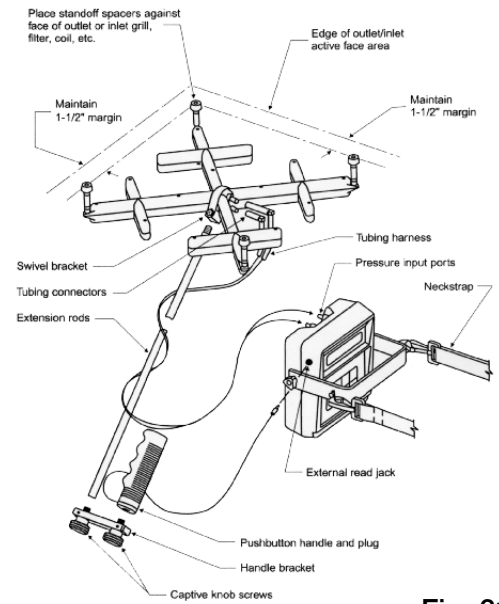

Fig. 31

Nominal Filter Size (H x L)		Imperial Conversion Factor	Metric Conversion Factor
Inches	Millimeters		
16 x 16	400 x 400	1.66	.154
16 x 20	400 x 500	2.10	.195
20 x 16	500 x 400	1.96	.182
20 x 20	500 x 500	2.40	.223

Example: Measured velocities for 20 x 20 filter = 185 and 189 fpm

$$\text{Average Velocity} = \frac{\text{Sum of Velocity Readings}}{\text{Number of Readings}}$$

$$\text{(Imperial)} = \frac{185 + 189}{2} = \underline{187.0 \text{ fpm}}$$

$$\text{(Metric)} = \frac{3383 + 3456}{2} = \underline{3420 \text{ m/hr}}$$

$$\begin{aligned} \text{Flow rate for one filter} &= \text{Conversion Factor} \times \text{Average Velocity} \\ &= 2.40 \times 187.0 \text{ fpm} = \underline{448.8 \text{ cfm}} \\ &= .223 \times 3420 \text{ m/hr} = \underline{763 \text{ m}^3/\text{hr}} \end{aligned}$$

$$\begin{aligned} \text{Total hood flow rate} &= (\text{Filter 1 Flow Rate}) + \dots + (\text{Filter X Flow Rate}) \\ &= 448.8 + 457.8 + 437.5 + 444.8 = \underline{1788.9 \text{ cfm}} \\ &= 763 + 778 + 743 + 756 = \underline{3040 \text{ m}^3/\text{hr}} \end{aligned}$$

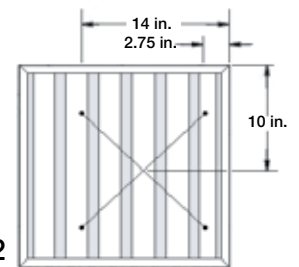

Fig. 32

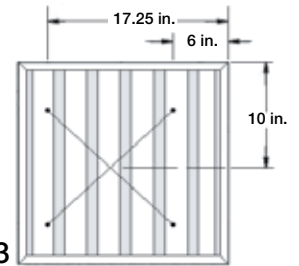

Fig. 33

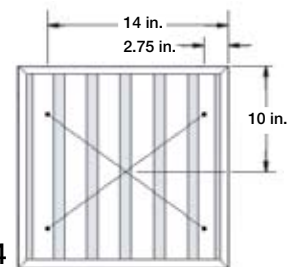

Fig. 34

High Velocity Cartridge Filters

A. Exhaust

With all the filters in place, determine the total hood exhaust volume with a rotating vane anemometer as follows:

1. All cooking equipment should be on. If the hood has internal short circuit make-up air, it should be turned off.
2. Measuring Velocities

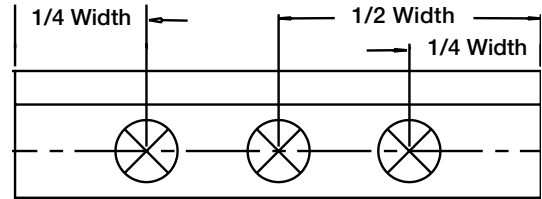

Fig. 35

- Velocity measurement should be taken at three locations per filter. These must be over the inlet opening as shown in Fig. 35.
 - Measure the velocity of each location. A digital 2.75 in. (70 mm) rotating vane anemometer or its equivalent is suggested. The center of the anemometer should be held 2 in. (50 mm) from the face of the filters as in Fig. 31. It is helpful to make brackets to keep the anemometer at the 2 in. (50 mm) distance and parallel to the filter. Both squareness and distance are important for accuracy.
3. Calculate the average slot velocity.
 4. Calculate the CFM per linear foot by dividing the average velocity by a conversion factor listed in the following table.
 5. Calculate the hood's exhaust volume by multiplying the CFM per linear foot by the length of hood.

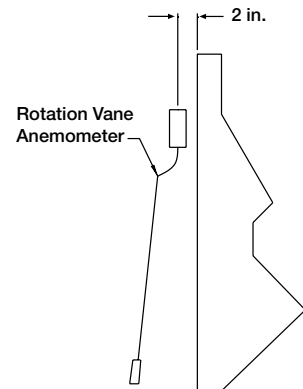

Fig. 36

Cartridge Filter Size	Imperial Conversion Factor	Metric Conversion Factor
16 in. (400 mm) high with 4 in. (100 mm) high inlet	1.63 1/ft ³	5.35 1/m ³
20 in. (500 mm) high with 4 in. (100 mm) high inlet	2.15 1/ft ³	7.05 1/m ³
16 in. (400 mm) high with 7 in. (120 mm) high inlet	1.24 1/ft ³	4.07 1/m ³
20 in. (500 mm) high with 7 in. (120 mm) high inlet	1.58 1/ft ³	5.18 1/m ³

Example:

Measure the slot velocities in fpm for a 9 ft. (2.74 m) hood with four 20 x 20 in. (500 x 500 mm) filters with standard opening, three readings per filter.

$$\text{Average slot velocity} = \frac{\text{Sum of Velocity Readings}}{\text{Number of Readings}}$$

$$\text{(Imperial)} = \frac{5330}{12} = \underline{444.2 \text{ fpm}}$$

$$\text{(Metric)} = \frac{97474}{12} = \underline{8123 \text{ m/hr}}$$

$$\text{CFM per linear foot} = \frac{\text{Average Slot Velocity}}{\text{Conversion Factor}}$$

$$= \frac{444.2 \text{ fpm}}{2.15} = \underline{206.6 \text{ cfm/linear foot}}$$

$$= \frac{8123 \text{ m/hr}}{7.05} = \underline{1152 \text{ m}^3/\text{hr}}$$

$$\text{Hood exhaust volume} = \text{CFM/linear foot (m}^3/\text{hr / m)} \times \text{Hood Length}$$

$$= 206.6 \times 9 \text{ ft.} = \underline{1859.4 \text{ cfm}}$$

$$= 1152 \times 2.74 \text{ m} = \underline{3156 \text{ m}^3/\text{hr}}$$

Filter Readings (fpm)		
470	440	425
482	430	453
455	431	441
399	439	465
Filter Readings (m/hr)		
8595	8047	7772
8815	7864	8284
8321	7882	8065
7297	8028	8504

High Velocity Cartridge Filters

A. Exhaust

With all the filters in place, determine the total hood exhaust volume with a Shortridge meter as follows:

1. All cooking equipment should be on. If the hood has internal short circuit make-up air, it should be turned off.
2. Measuring Velocities
 - Set up the Shortridge meter. Leave all holes of Velgrid open. Do NOT tape over holes that are not over openings. The conversion factor takes this into account.
 - Position the grid over each filter as shown.
 - Take velocity readings for each filter.
3. *Calculate each filter's volumetric flow rate by summing the flow rate of each individual filter in the hood.
4. *Calculate the total hood's volumetric flow rate by summing the flow rate of each individual filter in the hood.

**Note: For best accuracy multiply the velocity of each filter by its conversion factor and sum the flow rates. Averaging the velocity measured for all filters may cause error.*

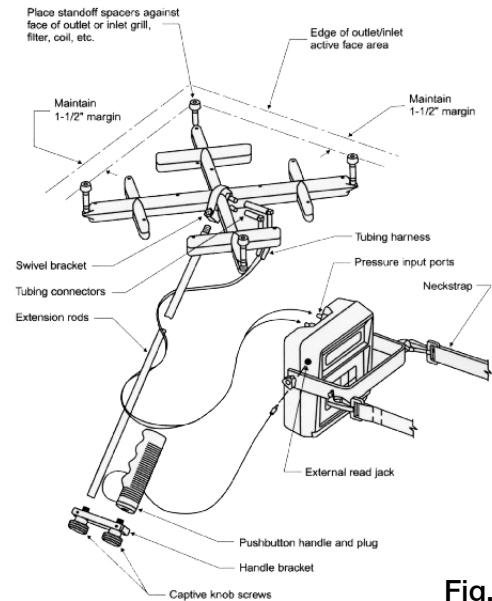

Fig. 37

Nominal Filter Size (H x L)		Imperial Conversion Factor	Metric Conversion Factor
Inches	Millimeters		
16 x 16	400 x 400	1.22 ft ²	.113 m ²
16 x 20	400 x 500	1.67 ft ²	.155 m ²
20 x 16	500 x 400	1.21 ft ²	.112 m ²
20 x 20	500 x 500	1.50 ft ²	.139 m ²

Example: Measured velocities for 20 x 20 filter = 282 fpm (5157 m/hr)

$$\begin{aligned}
 \text{Flow rate for one filter} &= \text{Conversion Factor} \times \text{Average Velocity} \\
 \text{(Imperial)} &= 1.50 \times 282 \text{ fpm} = \underline{423.0 \text{ cfm}} \\
 \text{(Metric)} &= .139 \times 5157 \text{ m/hr} = \underline{717 \text{ m}^3/\text{hr}}
 \end{aligned}$$

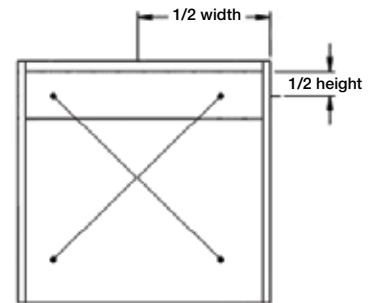

Fig. 38

$$\begin{aligned}
 \text{Total hood flow rate} &= (\text{Filter 1 Flow Rate}) + \dots + (\text{Filter X Flow Rate}) \\
 &= 423.0 + 421.8 + 420.7 + 418.2 = \underline{1683.7 \text{ cfm}} \\
 &= 717 + 717 + 715 + 711 = \underline{2860 \text{ m}^3/\text{hr}}
 \end{aligned}$$

A. Exhaust

With all the filters in place, determine the total hood exhaust volume with a rotating vane anemometer as follows:

1. All cooking equipment should be off. If the hood has internal short circuit make-up air, it should be turned off.
2. Measuring Velocities
 - Measurement should be taken at six locations per filter. They must be over the inlet opening as shown in Fig. 39.
 - Measure the velocity of each location. A digital 2.75 in. (70 mm) rotating vane anemometer or its equivalent is suggested. The center of the anemometer should be held 2 in. (50 mm) from the face of the filters as in Fig. 40. It is helpful to make brackets to keep the anemometer at the 2 in. (50 mm) distance and parallel to the filter. Both squareness and distance are important for accuracy.
3. Calculate the average velocity for the filter.
4. Determine the filter's conversion factor from the table.
5. Calculate each filter's volume in CFM by multiplying the average velocity by the conversion factor.

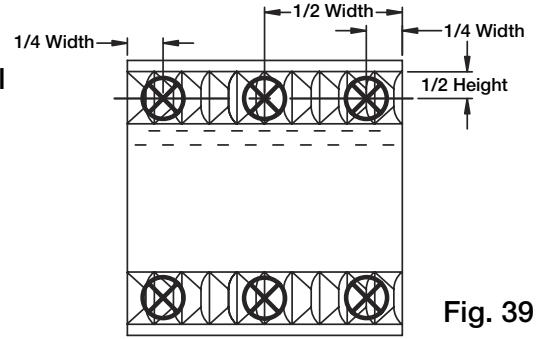

Fig. 39

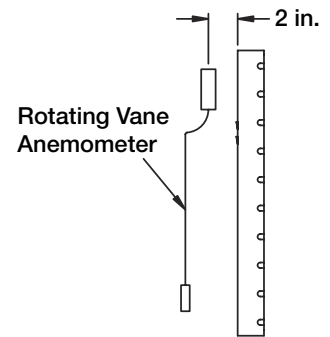

Fig. 40

Nominal Filter Size (H x L)		Imperial Conversion Factor	Metric Conversion Factor
Inches	Millimeters		
16 x 16	400 x 400	1.31 ft ²	.122 m ²
16 x 20	400 x 500	1.65 ft ²	.153 m ²
20 x 16	500 x 400	1.23 ft ²	.114 m ²
20 x 20	500 x 500	1.65 ft ²	.153 m ²

Example: (Imperial)

Hood Length = 7 feet 0 inches with four 20 x 20 filters.

Measure the velocities in fpm for each 20 x 20 filter (six readings per filter)

Filter 1	225	201	187
	210	238	197
Filter 2	228	222	226
	237	240	220
Filter 3	230	245	240
	250	223	219
Filter 4	225	265	219
	245	221	200

$$\begin{aligned} \text{Average slot velocity for Filter 1} &= \frac{\text{Sum of Velocity Readings}}{\text{Number of Readings}} \\ &= \frac{1258}{6} = 209.7 \text{ fpm} \\ &\text{(repeat for each filter)} \end{aligned}$$

For a nominal filter size of 20 x 20, the conversion factor is 1.65

$$\begin{aligned} \text{Volume for Filter 1} &= \text{Conversion Factor} \times \text{Average Velocity} \\ &= 1.65 \text{ ft}^2 \times 209.7 \text{ ft./min.} \\ &= 346.0 \text{ cfm (repeat for each filter)} \end{aligned}$$

Total hood volume

$$\begin{aligned} &= \text{Filter 1 Volume} + \text{Filter 2 Volume} + \text{Filter 3 Volume} + \text{Filter 4 Volume} \\ &= 346.0 + 377.6 + 386.9 + 378.1 = 1488.6 \text{ cfm} \end{aligned}$$

Example: (Metric)

Hood Length = 2.13 meters, with four 500 x 500 mm filters.

Measure the velocities in m/hr for each 500 x 500 mm filter (six readings per filter)

Filter 1	4114.80	3675.88	3419.86
	3840.48	4352.54	3602.74
Filter 2	4169.66	4059.94	4133.08
	4334.26	4389.21	4023.36
Filter 3	4420.12	4480.56	4389.12
	4572.00	4078.22	4005.07
Filter 4	4114.80	4846.52	4005.07
	4480.56	4041.65	3657.60

$$\begin{aligned} \text{Average slot velocity for Filter 1} &= \frac{\text{Sum of Velocity Readings}}{\text{Number of Readings}} \\ &= \frac{23006}{6} = 3834 \text{ m/hr} \\ &\text{(repeat for each filter)} \end{aligned}$$

For a nominal filter size of 500 x 500, the conversion factor is .153

$$\begin{aligned} \text{Volume for Filter 1} &= \text{Conversion Factor} \times \text{Average Velocity} \\ &= .153 \text{ m}^2 \times 3834 \text{ m/hr} \\ &= 586.7 \text{ m}^3/\text{hr (repeat for each filter)} \end{aligned}$$

Total hood volume

$$\begin{aligned} &= \text{Filter 1 Volume} + \text{Filter 2 Volume} + \text{Filter 3 Volume} + \text{Filter 4 Volume} \\ &= 587 + 642 + 657 + 642 = 2528 \text{ m}^3/\text{hr} \end{aligned}$$

Grease-X-Tractor™ High Efficiency Filters or Grease Grabber™ Multi-Filtration System

A. Exhaust

With all the filters in place, determine the total hood exhaust volume with a Shortridge meter as follows:

- All cooking equipment should be on. If the hood has internal short circuit make-up air, it should be turned off.
- Measuring Velocities
 - Set up the Shortridge meter. Leave all holes of Velgrid open. Do NOT tape over holes that are not over openings. The conversion factor takes this into account.
 - For 20 in. (500 mm) high filters, position the grid as shown in Fig. 42 and 43. Average the two measurements.
 - For 16 in. (400 mm) high filters position the grid as shown in Fig. 44.
 - For 20 in. (500 mm) wide filters, position the grid over the left and right side of the filter. Average the two measurements.
 - Take velocity readings for each filter.
- *Calculate each filter's volumetric flow rate by summing the flow rate of each individual filter in the hood.
- *Calculate the total hood's volumetric flow rate by summing the flow rate of each individual filter in the hood.

**Note: For best accuracy multiply the velocity of each filter by its conversion factor and sum the flow rates. Averaging the velocity measured for all filters may cause error.*

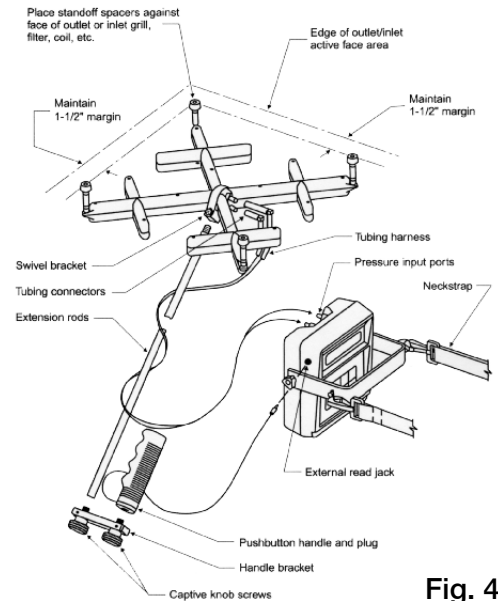

Fig. 41

Nominal Filter Size (H x L)		Imperial Conversion Factor	Metric Conversion Factor
Inches	Millimeters		
16 x 16	400 x 400	1.53 ft ²	.142 m ²
16 x 20	400 x 500	2.00 ft ²	.185 m ²
20 x 16	500 x 400	2.25 ft ²	.209 m ²
20 x 20	500 x 500	3.00 ft ²	.279 m ²

Example:

Measured velocities for 20 x 20 in. (500 x 500 mm) filter.

$$\text{Average slot velocity} = \frac{\text{Sum of Velocity Readings}}{\text{Number of Readings}}$$

$$\text{(Imperial)} = \frac{198 + 205}{2} = 201.5 \text{ fpm}$$

$$\text{(Metric)} = \frac{3021 + 3749}{2} = 3385 \text{ m/hr}$$

$$\begin{aligned} \text{Flow rate for one filter} &= \text{Conversion Factor} \times \text{Average Velocity} \\ &= 3.0 \times 201.5 \text{ fpm} = 604.5 \text{ cfm} \\ &= .279 \times 3385 \text{ m/hr} = 944 \text{ m}^3/\text{hr} \end{aligned}$$

$$\begin{aligned} \text{Total hood flow rate} &= \text{Filter 1 Flow Rate} + \dots + \text{Filter X Flow Rate} \\ &= 604.5 + 600.3 + 592.4 + 613.3 = 2410.5 \text{ cfm} \\ &= 944 + 1020 + 1006 + 1042 = 4012 \text{ m}^3/\text{hr} \end{aligned}$$

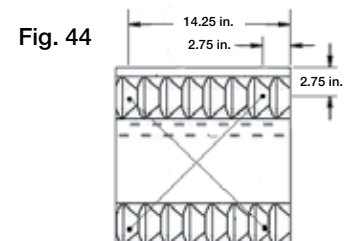
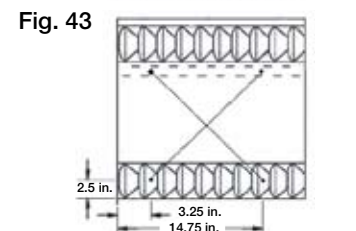
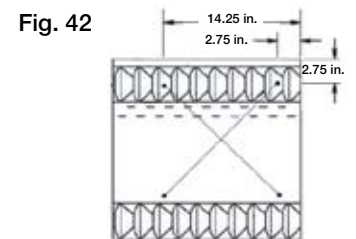

Testing Hood Air Volume

Short Circuit Hoods

A. Supply

All cooking equipment should be off. The hood exhaust should also be off.

1. Measuring Velocities

- Velocity measurements should be made with a digital 2.75 in. (70 mm) rotating vane anemometer or its equivalent.
- One velocity measurement should be taken for every 8 in. (200 mm) of short circuit opening length, starting tight against one edge of the opening, and finishing tight against the other edge. The anemometer should be placed at the bottom edge of the opening, flush with the bottom lip as shown in Fig. 45. Both squareness and placement are important for accuracy.

2. Calculate the average slot velocity.

3. Calculate the CFM per linear foot by dividing the average velocity by a conversion factor of 5.52 per ft. or 1.68 per m.

4. Calculate the hoods exhaust volume by multiplying the CFM per linear foot by the total hood length.

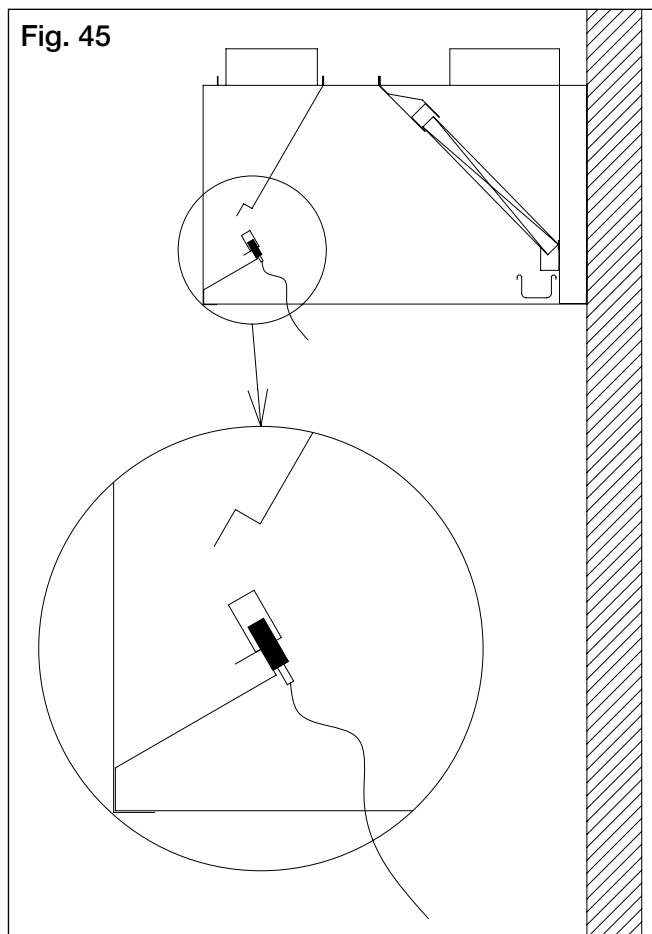

Example: 4 ft. (1.22 m) short circuit hood (36 in. (.914 m) short circuit opening):

Number of readings = 36 in. / 8 in. => 6 readings (.914 m / .2 m => 6 readings)

Average slot velocity = $\frac{\text{Sum of Velocity Readings}}{\text{Number of Readings}}$

$$\text{(Imperial)} = \frac{786 + 900 + 1126 + 1048 + 1111 + 1115}{6} = \frac{6086}{6} = \underline{1014.3 \text{ fpm}}$$

$$\text{(Metric)} = \frac{1335 + 1529 + 1913 + 1780 + 1888 + 1894}{6} = \frac{10339}{6} = \underline{1723 \text{ m/hr}}$$

CFM per linear foot = $\frac{\text{Average Slot Velocity}}{\text{Conversion Factor}}$

$$= \frac{1014.3 \text{ fpm}}{5.52} = \underline{183.8 \text{ cfm/linear foot}}$$

$$= \frac{1723 \text{ m/hr}}{1.68} = \underline{1026 \text{ m}^3/\text{hr}}$$

Hood supply volume = CFM/linear foot (or m³/hr) x Total Hood Length

$$= 183.8 \quad \times \quad 4 \text{ ft.} \quad = \underline{735.2 \text{ cfm}}$$

$$= 1026 \quad \times \quad 1.22 \text{ m} \quad = \underline{1252 \text{ m}^3/\text{hr}}$$

Amerex Wiring Plan View

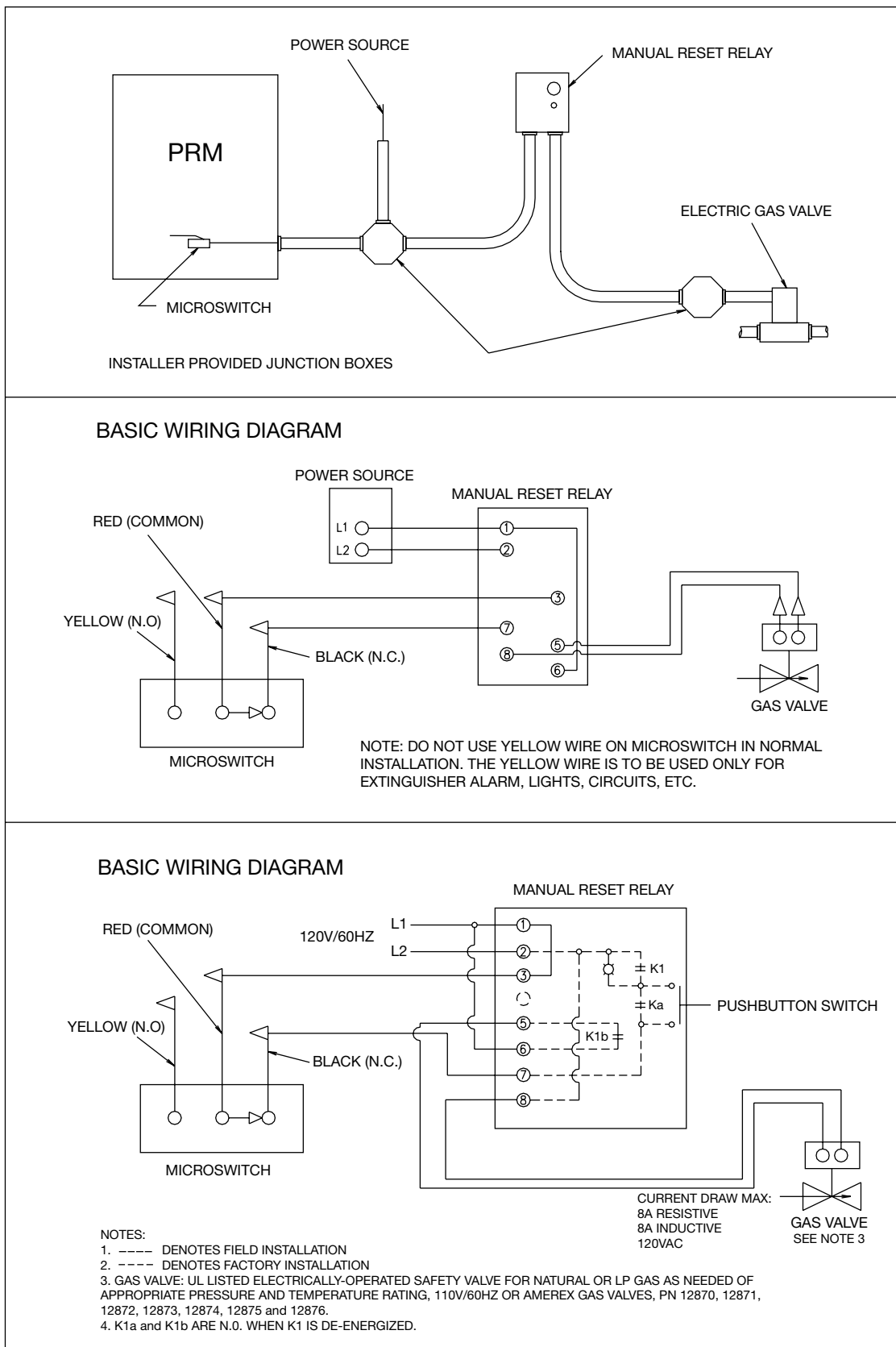
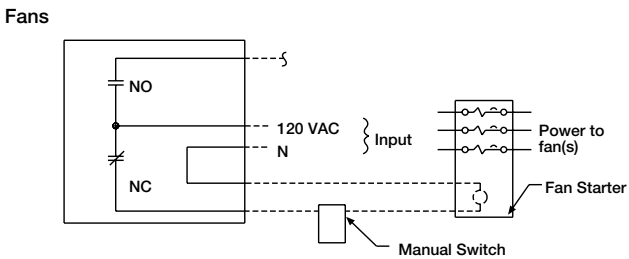
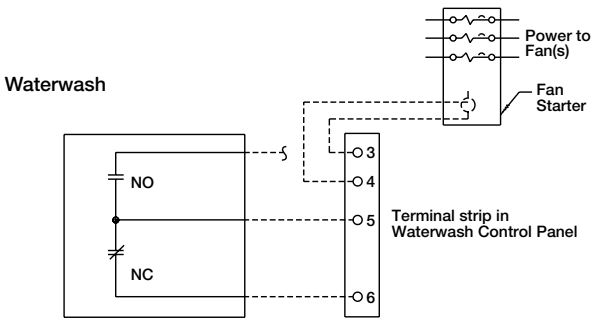
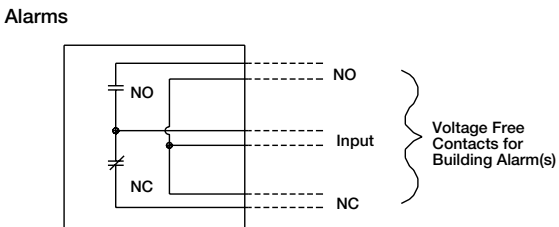
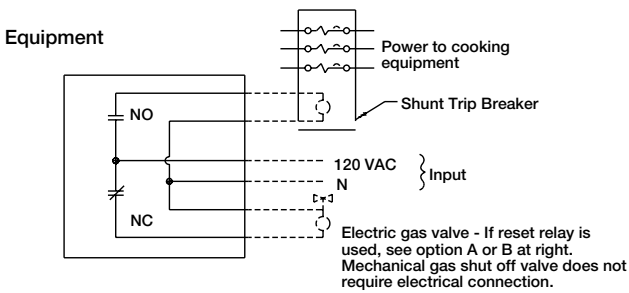

Fig. 46

Ansul Wiring Plan View

2 Snap-Action Switches provided by Greenheck may be wired as shown. Four typical examples shown



If prohibited by local codes, do not shut down exhaust fans with this method of wiring.

Option A Relay Part No. 14702

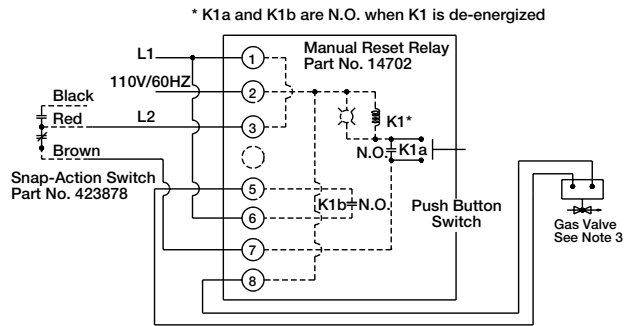

Option B Relay Part No. 426151

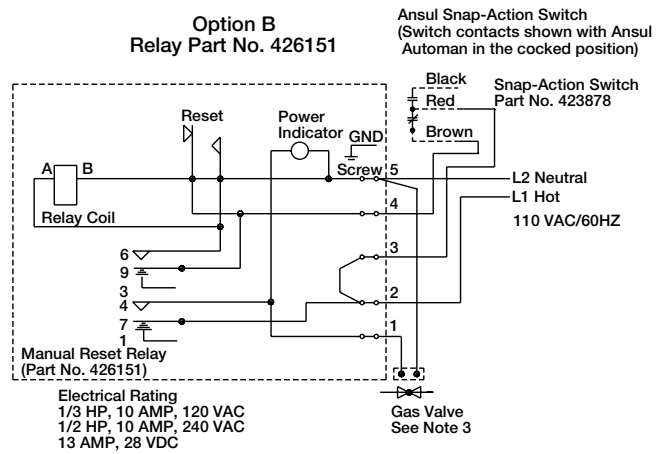

Note:

1. ——— Denotes field installation.
2. - - - - - Denotes factory installation.
3. Gas Valves: "UL Listed electrically-operated safety valve for natural or LP gas as needed of appropriate pressure and temperature rating, 110V/60HZ" or Ansul gas valves.
4. Do not use black wire on snap-action switch in normal installation. Black wire may only be used for extraneous alarm, light circuits, etc.

Fig. 47



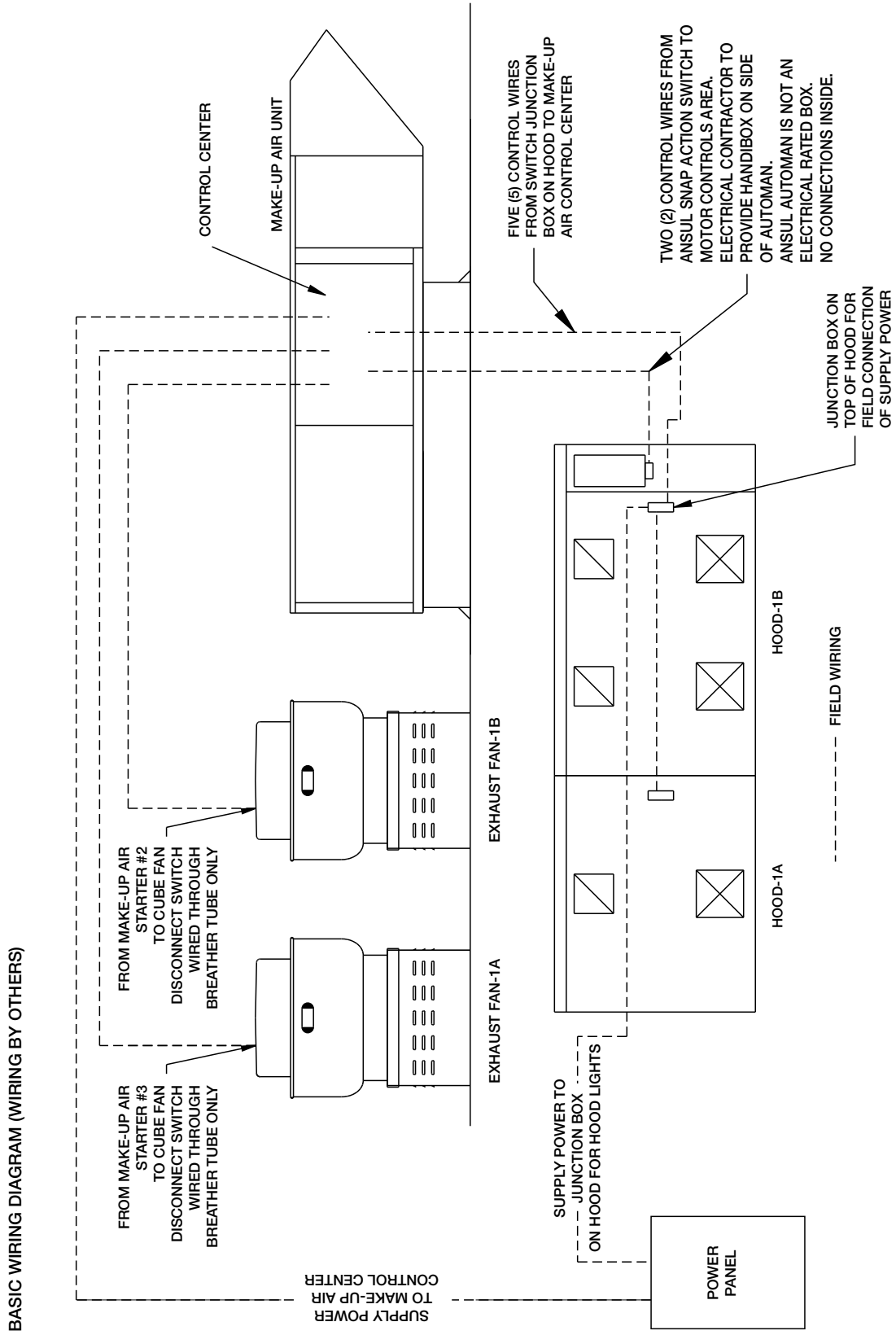

Fig. 48

Wiring for Hood Switch Panels

The diagrams below show a typical hood switch panel remote mounted. For hood mounted switches refer to the wiring connection decal on the cover of the junction box on the hood top.

The diagram below shows how to wire the exhaust and supply fans with a control panel to a fire suppression contact (FSC1). When wired properly, the supply fan will be turned off if the fire system is activated and allow the exhaust fan to continue to operate.

The fire suppression contact (FSC1) is provided as part of the fire suppression system and is normally mounted in the fire system control box.

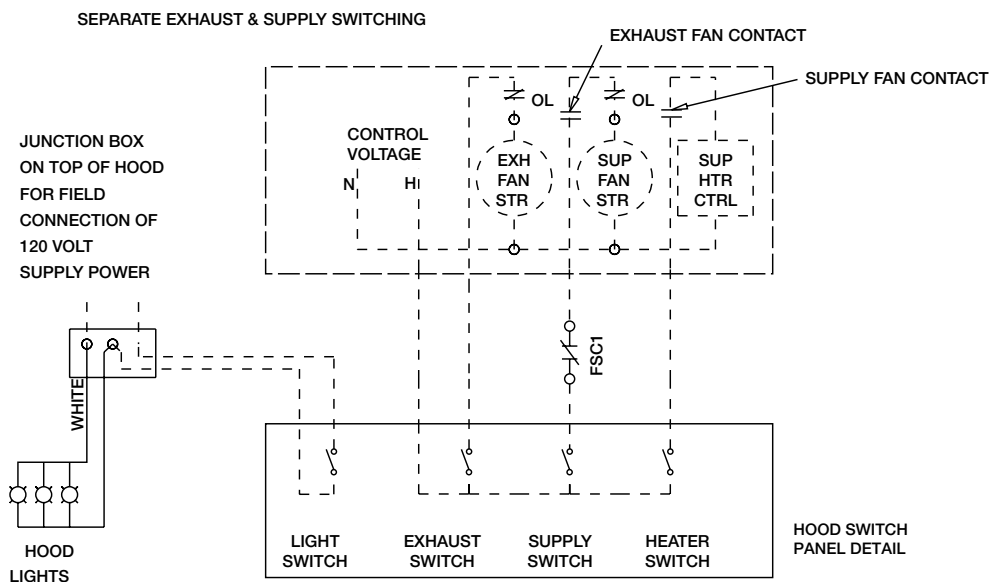
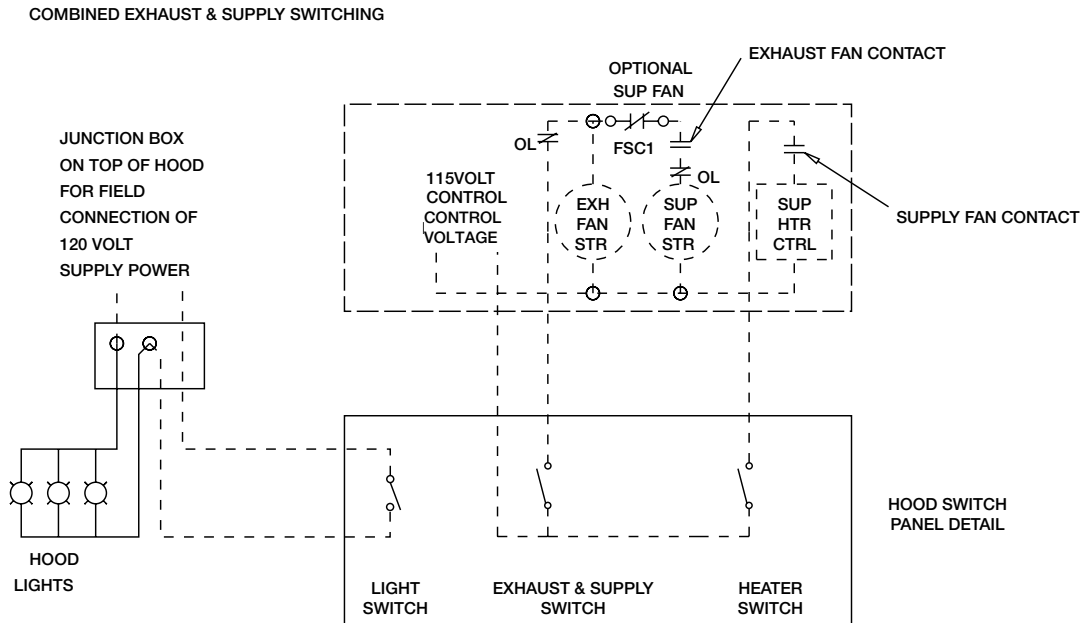

Fig. 49

Circuit Diagrams

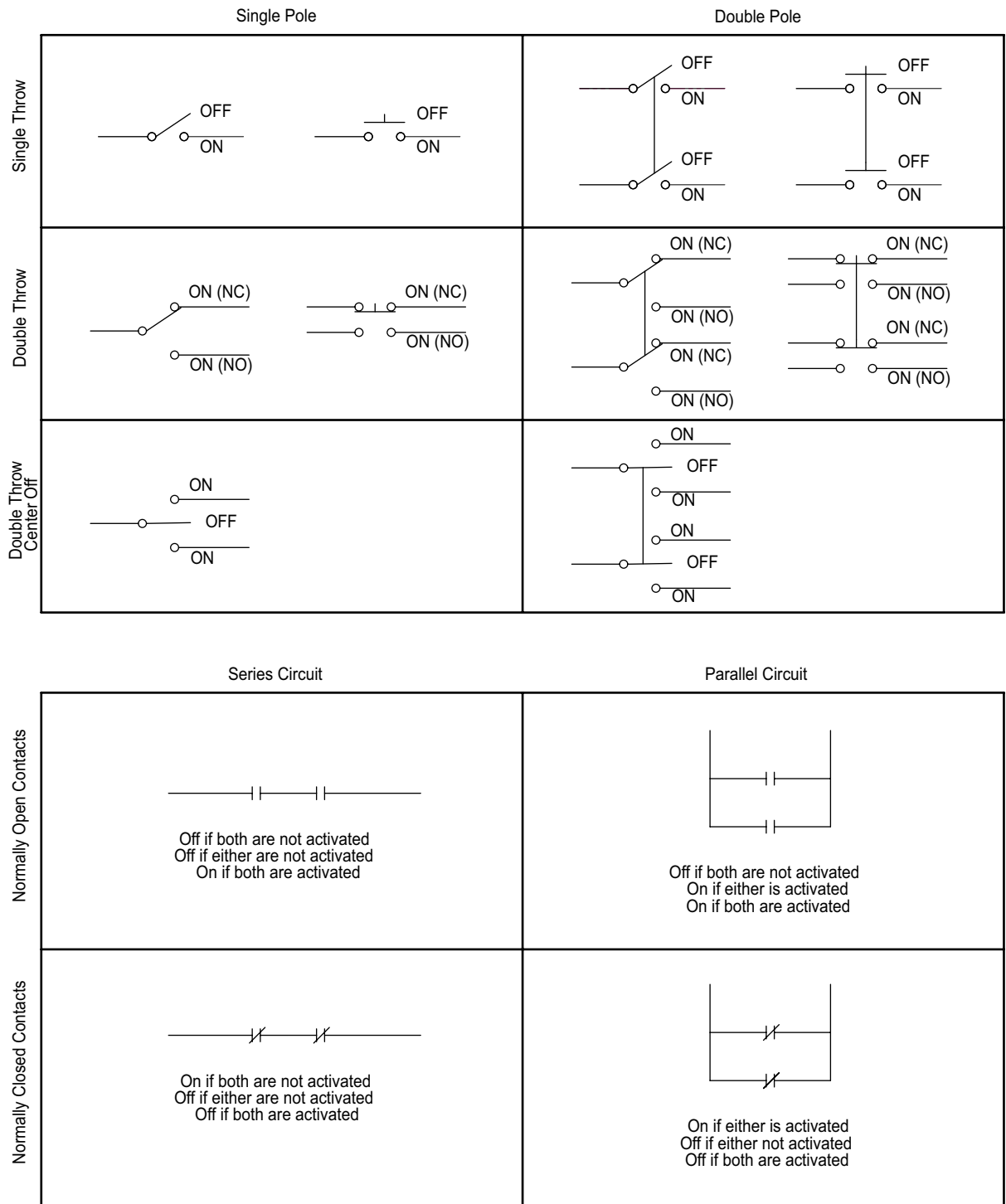

Fig. 50

Maintenance

Daily Maintenance

1. Wipe grease from exposed metal surfaces on the hood interior using a clean, dry cloth.
2. Visually inspect the filters or cartridges for grease accumulation.
3. Remove grease cup, empty contents, and replace cup.

Weekly Maintenance

1. Remove the grease filters or cartridges and wash in dishwasher or pot sink.

Note: Filters installed over heavy grease producing equipment may require more frequent cleaning. See filter cleaning schedule.

2. Before replacing filters, clean the interior plenum surfaces of any residual grease accumulations.

Periodic Maintenance

1. Painted hood exterior surfaces should be cleaned with a mild detergent solution.
2. Stainless steel hood exterior surfaces should be cleaned with a mild detergent and then polished with a good grade stainless steel polish to preserve the original luster.

Note: Never use abrasive cleaners or chemicals on hood surfaces. Never use chlorine based cleaners or iron wool pads to clean the hood. They may scratch or mar the material. Always rub with the grain of the stainless.

3. To maintain optimum performance of your hood and fan, duct cleaning should be performed as often as the application and code requires.
4. Re-caulk the hoods with an NSF Approved silicone caulk, (GE SCS1009 or its equivalent) as needed.

Condensate Hood Baffle Installation

1. Grasp the baffle with drain holes facing down and lift into the hood. For short hoods with only one baffle it may be necessary to turn the baffle slightly diagonal to fit it past the drain channel.
2. After the baffle clears the drain channel of the hood, turn the baffle so it is lined up with the upper hanger in the hood.
3. Hook the upper channel of the baffle over the upper hanger of the hood and set the lower edge of the baffle into the condensate gutter. Repeat until all baffles are installed in the hood.
4. Center the baffle from side to side in the hood.

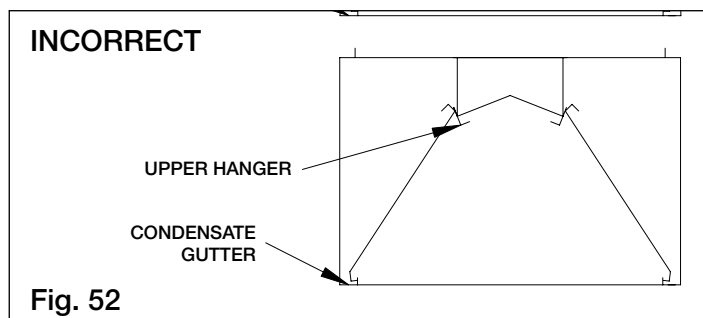
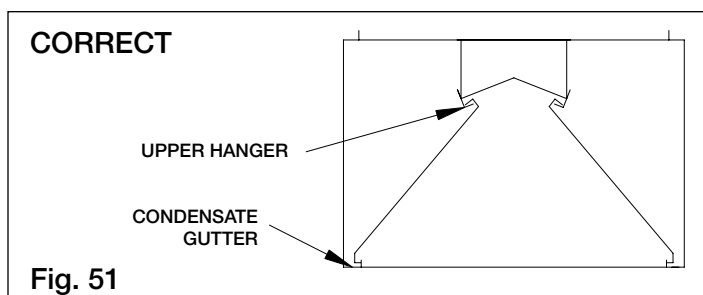

Grease Grabber™ Filter Installation

NOTE: Never install the Second Stage filter in the front filter channel. The Second Stage filter must be installed behind a UL Classified Grease-X-Tractor™ primary filter Model HE or GX.

1. Slide the top edge of the Second Stage filter into the top rear filter channel; Fig. 53.
2. Lifting the lower edge of the filter past the grease trough, continue to push the top of the filter into the channel.
3. When the filter is even with the bottom rear filter channel, set the filter into the channel; Fig. 54.
4. Slide the filter to one end of the hood and repeat until all the filters are installed. Make sure the filters are placed tightly together with no visible gaps.
5. Latch filters together by connecting hooks to handle on next filter; Fig. 55.
6. Install the Grease-X-Tractor™ primary filters in the same manner using the front filter channel.

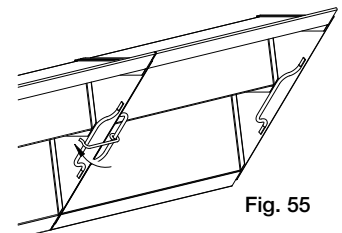
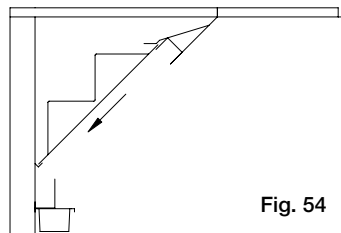
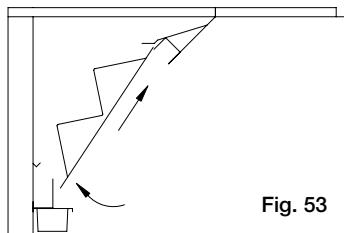

Grease Grabber™ Filter Cleaning

Step 1 Remove the front GX filters: (1A) Remove middle filters first, (1B) slide ends toward middle and remove.



1A



1B



1C

Step 2 Release the hooks that hold the filters together. Slide the top hook upward and the bottom hook downward until the hook releases. Do this to all filters.

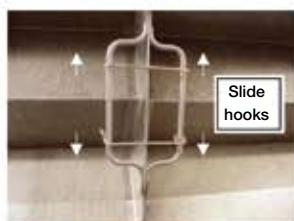

2A



2B



2C

Step 3 Remove the GG filters, starting in the middle of the hood: (3A) Grab the handles on either side and lift the filter up, (3B) pull the bottom of the filter toward yourself, (3C) lower the filter out of the hood. Repeat this process for each filter. The filters that are on the ends will have to be slid toward the middle and then lifted out.

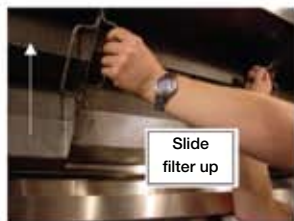

3A



3B



3C

Step 4 **Frequent Maintenance:**

Note: Required washing frequency is dependent on type of cooking and quantity of food cooked.

- Remove filters from hood and place each filter in a whirlpool sink or dishwasher.
- If using a whirlpool sink, cycle for 10 minutes. Use standard dishwash soap. (4A)
- If using a dishwasher, cycle it three times to ensure all grease is removed. (4B)
- If using standard sink, cover with hot water and degreaser and soak for two hours. Rinse after soaking.

Note: For hoods with large quantities of filters, it is acceptable to wash 3 to 4 filters each day, cycling all of the filters in three days.

Note: The beads will discolor. Standard cooking will turn the beads yellow in color. Open flame cooking will cause the beads to blacken. Neither affects the performance of the filters.

Periodic Inspection:

- Each filter may be soaked in hot soapy water for two hours once a month prior to washing if grease build-up is found.
- Inspect the filters by holding it up to a light. Light shining through more than six holes in a group indicates filter damage.
- For filter replacement, call 1-800-337-7400



4A



4B

Step 5 Replace GG filters in hood. Do Step 3 in reverse order. (3C, then 3B, then 3A)

Step 6 Latch filters together by connecting the hooks to the handle on the next filter. Slide hook on from the top and bottom of the handle. Do not try to snap the hooks into place. Do Step 2 in reverse.

Step 7 Replace the front GX filters. Do Step 1 in reverse. Be sure to install filters in the ends of the hood first, then install the filters in the middle of the hood (1B, then 1A)

Caution: To prevent damage to filter media, do not wash second stage filters in detergents that contain hydroxides such as sodium hydroxide or potassium hydroxide.

Filter Washing Frequency Guide

NOTE: Standard cooking will turn the beads yellow in color. Open flame cooking will cause the beads to blacken. Neither affects the performance of the beads.

Caution: To prevent damage to filter media, do not wash second stage filters in detergents that contain hydroxides such as sodium hydroxide or potassium hydroxide.

Preference	Washing Equipment		Cooking Equipment	Chemical	Frequency Required	Time or Cycles	Baffle Filter or Grease-X-Tractor™ Wash Frequency
	Type	Temp					
1 Best	Commercial Grade Dish Washer	180° F Min	Griddle	Dish Washer Detergent	Every 3 days	2 Cycles	Every 3 days 2 Cycles
			Fryer		Weekly	2 Cycles	Twice a week 1 Cycle
			Charbroiler		Daily	2 Cycles	Daily 2 Cycles
			Wok		Daily	2 Cycles	Daily 2 Cycles
2	Low Temp. Dish Washer (Chemical Sanitizer)	140° F	Griddle	Dish Washer Detergent	Every 3 days	3 Cycles	Every 3 days 2 Cycles
			Fryer		Weekly	3 Cycles	Twice a week 2 Cycles
			Charbroiler		Daily	4 Cycles	Daily 2 Cycles
			Wok		Daily	4 Cycles	Daily 2 Cycles
3	Power Wash Sink (Whirlpool) with Heater	180° F Min	Griddle	Pot & Pan Detergent	Every 3 days	10 Minutes	Every 3 days 5 minutes
			Fryer		Weekly	10 Minutes	Twice a week 5 minutes
			Charbroiler		Daily	15 Minutes	Daily 5 minutes
			Wok		Daily	15 Minutes	Daily 5 minutes
4	Power Wash Sink (Whirlpool) no Heater	140° F	Griddle	Pot & Pan Detergent	Every 3 days	15 Minutes	Daily 5 minutes
			Fryer		Weekly	15 Minutes	Twice a week 5 minutes
			Charbroiler		Daily	25 Minutes	Daily 10 minutes
			Wok		Daily	25 Minutes	Daily 10 minutes
5	Pot Sink with Heater (rinse with sprayer after soaking)	180° F	Griddle	Pot & Pan Detergent and/or Degreaser	Every 2 days	1 Hour	Daily Soak 10 min., then scrub with scour pad and bottle brush
			Fryer		Every 2 days	1 Hour	Daily Soak 5 min., then scrub with scour pad and bottle brush
			Charbroiler		Daily	2 Hours	Daily Soak 10 min., then scrub with scour pad and bottle brush
			Wok		Daily	2 Hours	Daily Soak 10 min., then scrub with scour pad and bottle brush
6 Worst	Pot Sink no Heater (rinse with sprayer after soaking)	140° F	Griddle	Commercial Grade Kitchen Degreaser	Daily	2 Hours Change hot water every 30 minutes	Daily Soak 10 minutes then scrub with scour pad & bottle brush
			Fryer		Every 2 days	2 Hours Change hot water every 30 minutes	
			Charbroiler		Not Recommended		
			Wok		Not Recommended		

Troubleshooting

Problem: Exhaust fan is not operating or is not operating at design levels.

Is the fan receiving power?	Replace fuses, reset circuit breakers, check disconnect.
Is the belt loose or broken?	Replace or tighten belt.
Is the fan rotating in correct direction?	Have the electrician correctly wire the fan.
Is the make-up air operating?	Problems with make-up air may interfere with the exhaust fan - check the manufacturers installation manual.
Does the airflow need to be increased?	Adjust or replace pulleys to increase fan RPM, install a larger motor.
Does the fan vibrate?	Clean the fan wheel/blade, replace fan wheel if damaged, check for loose bolts, check for broken or damaged components, check for rags and other foreign objects.

Problem: Hood is full of smoke. There is smoke coming out of the edges of the hood.

Is the fan operating at design levels?	See exhaust fan troubleshooting section.
Is the fan correctly sized?	Refer to test and balance report, design specifications and fan curves; have an electrician check the motor amperage; try removing the filter temporarily to see if capture improves. (Make sure to replace filter to prevent risk of fire!); switch to different filters with lower static pressure.
Are the filters in good condition?	Clean filters, replace damaged filters, properly position filters.
Is there sufficient make-up air? <i>(Kitchen should be in a slight negative but not excessive. Check to see if there is a strong draft through an open door).</i>	Check make-up air unit, increase make-up air, make-up air should be evenly distributed throughout the kitchen.
Does the current cooking equipment match the original design?	Adjust or replace fan to match the cooking equipment load.
Are there multiple hoods on one fan?	One hood may be over exhausting and the other hood not drawing enough. Restrict second hood to help problem hood.
Are there closed dampers in the duct?	Open dampers.
Is the ductwork complex or too small?	Change to a higher static fan, modify the ductwork.
Is the ductwork obstructed?	Clear obstruction.
Is this a short circuit hood?	Turn off or reduce the amount of air supplied to short circuit.

Problem: Smoke blows away before reaching the bottom of the hood.

Are there cooling fans directed at the hood or cooking equipment?	Turn off or redirect fans.
Are there ceiling diffusers directing air at the hood?	Move diffusers to more neutral area or replace with a diffuser that directs air away from the hood.
Are there open windows or doors?	Close windows and doors.
Are there cross drafts or other drafts in the kitchen?	Find source of the draft and eliminate, add side skirts to hood (test with cardboard – use stainless for permanent side skirts); increase the amount of overhang on the spillage side; add a 6 in. lip around the base of the hood (test with cardboard – use stainless for permanent side skirts); make-up air should be spread out evenly through the kitchen.
Is the hood near a main walkway?	Add side skirts to hood (test with cardboard first); increase the amount of overhang on spillage side.

Troubleshooting

Problem: Smoke blows away before reaching the bottom of the hood.

Are there pass-thru windows near the hood?	Adjust amount and locations of make-up air to eliminate drafts through the pass-thru windows.
Is this an air curtain hood?	Turn off or reduce the amount of make-up air.
Is the make-up air part of the hood or an attached plenum?	Try turning off or reducing the amount of make-up air; block off portions of the supply to direct air away from the problem area (test with cardboard).

Problem: Pilot lights are being blown out or cooking equipment is being cooled by make-up air.

Are there drafts from make-up air?	Try turning off or reducing the amount of make-up air; block off portions of the supply to direct air away from the problem area (test with cardboard first); remove any obstructions in front of supply that directs air toward cooking equipment.
------------------------------------	---

Problem: Cold air can be felt by the cook at the hood.

Is this a short circuit hood?	Turn off or reduce the amount of air supplied to short circuit.
Is this an air curtain hood?	Turn off or reduce the amount of air supplied to the air curtain; heat the supply air.
Is the make-up air part of the hood or an attached plenum?	Try turning off or reducing the amount of make-up air; heat the supply air.

Problem: The kitchen gets hot.

Is the hood capturing?	Hood is not drawing enough air, see sections above on fan performance and hood capture.
Is this an air curtain hood?	Turn off or reduce the amount of air supplied to the air curtain.
Is the make-up air part of the hood or an attached plenum?	Try turning off or reducing the amount of make-up air; cool the supply air.

Problem: Cooking odors in the dining area.

Is the hood capturing?	Hood is not drawing enough air, see sections above on fan performance and hood capture.
Is there a draft through doors between the kitchen and dining area?	Decrease make-up air in the kitchen; increase exhaust air through hood.

Problem: Grease is running off the hood.

Is there grease on top of the hood?	Exhaust duct is not correctly welded.
Is the caulk missing or damaged?	Clean problem area and re-caulk.
Is the grease cup inserted properly?	Put grease cup back in place.

Problem: Hood is noisy.

Is the fan running in the correct direction?	See exhaust fan troubleshooting section.
Are the filters in place?	Replace missing filters.
Is the hood over exhausting?	Slow down fan (see exhaust fan troubleshooting section)

Before calling your manufacturers representative to report a problem have the following information available:

1. Review / summary of troubleshooting section in installation operation manual.
2. Hood model and serial number.
3. Current cooking equipment line-up.
4. Size of hood (length, width and height).
5. Island or wall configuration.
6. Multiple hoods on one fan.
7. Nature of spillage (one end; all around the edges).
8. Does the smoke make it to the hood?
9. Height hood is mounted above finished floor.
10. How make-up air is brought into the kitchen (hood, ceiling diffusers, separate plenum).
11. Is exhaust system controlled by a variable volume system?
12. Is the fan noisy?

Replacement Parts

GREENHECK PART NUMBER	FILTER DESCRIPTION (HEIGHT X WIDTH X DEPTH)
457626	16 x 16 x 2 Aluminum Baffle Filter
457628	16 x 20 x 2 Aluminum Baffle Filter
457632	20 x 16 x 2 Aluminum Baffle Filter
457634	20 x 20 x 2 Aluminum Baffle Filter
457627	16 x 16 x 2 Stainless Steel Baffle Filter
457629	16 x 20 x 2 Stainless Steel Baffle Filter
457633	20 x 16 x 2 Stainless Steel Baffle Filter
457635	20 x 20 x 2 Stainless Steel Baffle Filter
851656	16 x 16 High Velocity Cartridge Filter
851657	16 x 20 High Velocity Cartridge Filter
851659	20 x 16 High Velocity Cartridge Filter
851660	20 x 20 High Velocity Cartridge Filter
851703	16 x 16 Grease-X-Tractor™ Aluminum Filter
851704	16 x 20 Grease-X-Tractor™ Aluminum Filter
851706	20 x 16 Grease-X-Tractor™ Aluminum Filter
851707	20 x 20 Grease-X-Tractor™ Aluminum Filter
851709	16 x 16 Grease-X-Tractor™ SS Filter
851710	16 x 20 Grease-X-Tractor™ SS Filter
851712	20 x 16 Grease-X-Tractor™ SS Filter
851713	20 x 20 Grease-X-Tractor™ SS Filter
458763	16 x 16 Flame Gard® 1 Baffle Filter
458764	16 x 20 Flame Gard® 1 Baffle Filter
454878	20 x 16 Flame Gard® 1 Baffle Filter
454879	20 x 20 Flame Gard® 1 Baffle Filter
852208	20 x 16 Grease Grabber™ Second Stage Filter
852207	20 x 20 Grease Grabber™ Second Stage Filter
852388	16 x 16 Grease Grabber™ Second Stage Filter
852389	16 x 20 Grease Grabber™ Second Stage Filter

Replacement Parts

GREENHECK PART NUMBER	REGISTERS
452700	24 x 8 Aluminum Single Deflection H-OB
452701	36 x 8 Aluminum Single Deflection H-OB
452702	36 x 8 Aluminum Single Deflection H-OB
452703	44 x 8 Aluminum Single Deflection H-OB
453796	24 x 12 Aluminum Single Deflection H-OB
453797	36 x 12 Aluminum Single Deflection H-OB
453798	38 x 12 Aluminum Single Deflection H-OB
453799	44 x 12 Aluminum Single Deflection H-OB
452729	24 x 8 Aluminum 38° Fixed Blade RA-OB
452730	30 x 8 Aluminum 38° Fixed Blade RA-OB
452731	36 x 8 Aluminum 38° Fixed Blade RA-OB
452732	38 x 8 Aluminum 38° Fixed Blade RA-OB
452733	44 x 8 Aluminum 38° Fixed Blade RA-OB
GREENHECK PART NUMBER	SWITCHES
850551	Light Switch Only
851776	Fan Switch Only
851777	Light Switch & Fan Switch (2 switches)
851778	Fan Switch & Heat Switch (2 switches)
851779	Exhaust, Fan & Supply Switch (2 switches)
851780	Light, Fan & Heat Switch (3 switches)
851781	Light, Exhaust, Supply Separate Switch (3 switches)
851782	Exhaust, Supply, Heat Separate Switch (3 switches)
851783	Light, Exhaust, Supply, Heat Separate Switch (4 switches)
851784	Fan Switch & Temper (3 position) (2 switches)
851510	Light, Fans, & Temper (3 position) (3 switches)
851511	Exhaust, Supply, & Temper (3 position) (3 switches)
851512	Light, Exhaust, Supply, & Temper (3 position) (4 switches)
851618	Automatic Fire Damper Test Switch
GREENHECK PART NUMBER	MISCELLANEOUS
451131	Grease Cup
453498	Glass Globes for hood lights (clear)
851744	Grease Extractor Filter Removal Tool
851834	Baffle Filter Removal Tool
851747	High Velocity Cartridge Filter Removal Tool

Warranty

Greenheck warrants this equipment to be free from defects in material and workmanship for a period of one year from the shipment date. Any units or parts which prove defective during the warranty period will be replaced at our option when returned to our factory, transportation prepaid. Motors are warranted by the motor manufacturer for a period of one year. Should motors furnished by Greenheck prove defective during this period, they should be returned to the nearest authorized motor service station. Greenheck will not be responsible for any removal or installation costs.

As a result of our commitment to continuous improvement, Greenheck reserves the right to change specifications without notice.

Contact Greenheck Fan Corporation:

Phone: (715) 359-6171 • Fax: (715) 355-2399 • E-mail: gfcinfo@greenheck.com • Website: www.greenheck.com

