

Application and Design

Ductmate® is used to connect a damper sleeve to a rectangular duct when a tight duct connection is required. The Ductmate connector gives a nearly airtight cross connection without the use of slip joints, and is an acceptable breakaway connection when installed properly.

Particular attention should be given to the length of the sleeve extending beyond the wall or floor. The determining factor is dependent on whether or not there is an actuator and/or access door. If there is no actuator and/or factory mounted access door, the maximum is 6 inches (152mm) extending beyond the wall or floor. If there is an actuator or factory access door on the side of the wall, the maximum is 16 inches (406mm).

Versa-cleats are available in packages of 10, 25, or 50. See installation instructions for spacing of cleats (468502 Quick Connect Breakaway Supplement).

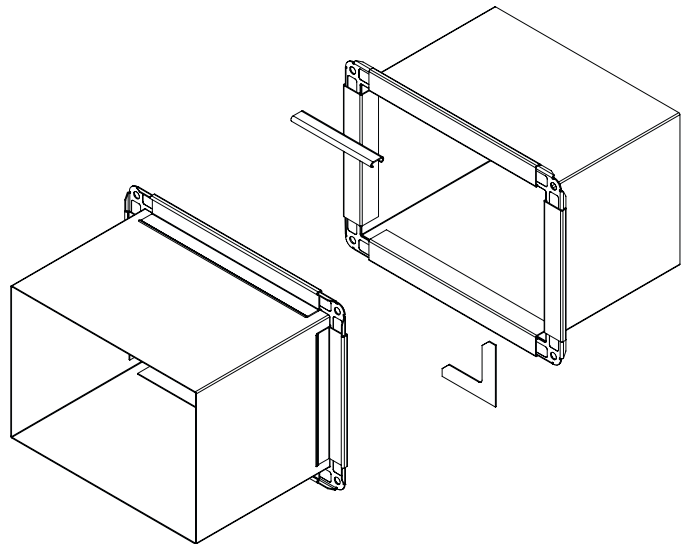

Standard Construction

Flange: 20 ga. (1mm) galvanized

Corner Clips: Galvanized

Gasket: Extruded butyl for use between mating flanges (not supplied by Greenheck)

Sleeve: Maximum thickness - 16 ga. (1.5mm) galvanized steel

Mounting Options

One side: Actuator side (FSD/SMD series)
K side (DFD/FD series)

Both Sides: Actuator or K side attached/ Opposite side unattached or both sides mechanically fastened

Size Limitations

FSD/SMD series: Minimum damper size is 8 in. W x 6 in. H (203mm x 152mm) Maximum width is based on model limitations. Maximum height is limited to 84 inches (2133mm).

FD/DFD series: Minimum damper size is 6in. W x 6 in. H (152mm x 152mm) Maximum width and height is based on model limitations.

| Screw Spacing Schedule (per Ductmate instructions) | | |
|--|---|--|
| Duct wall size inches (mm) | 0-4 in. wg (0 - 1 kPa) | 6 in. wg (1.5 kPa) |
| 0-24 (0 - 610) | 1 screw each corner | 1 screw each corner |
| 25-48 (635 - 1219) | 1 screw each corner plus 1 @ center | 1 screw each corner plus 1 @ center |
| 49 and over (1245 and over) | 1 screw each corner plus 1 screw each 24 inches (610mm) | 2 screws each corner plus 1 screw each 24 inches (610mm) |