

# *Grizzly* **Industrial, Inc.**®

## **MODEL G0715P POLAR BEAR SERIES® 10" HYBRID TABLE SAW w/RIVING KNIFE OWNER'S MANUAL**



 232857  
C US

COPYRIGHT © JULY, 2010 BY GRIZZLY INDUSTRIAL, INC. REVISED MARCH, 2011 (BL)  
**WARNING: NO PORTION OF THIS MANUAL MAY BE REPRODUCED IN ANY SHAPE  
OR FORM WITHOUT THE WRITTEN APPROVAL OF GRIZZLY INDUSTRIAL, INC.**  
(FOR MODELS MANUFACTURED SINCE 4/11) #13072TRCRBLTSJB PRINTED IN CHINA



## **WARNING!**

**This manual provides critical safety instructions on the proper setup, operation, maintenance, and service of this machine/tool. Save this document, refer to it often, and use it to instruct other operators.**

**Failure to read, understand and follow the instructions in this manual may result in fire or serious personal injury—including amputation, electrocution, or death.**

**The owner of this machine/tool is solely responsible for its safe use. This responsibility includes but is not limited to proper installation in a safe environment, personnel training and usage authorization, proper inspection and maintenance, manual availability and comprehension, application of safety devices, cutting/sanding/grinding tool integrity, and the usage of personal protective equipment.**

**The manufacturer will not be held liable for injury or property damage from negligence, improper training, machine modifications or misuse.**



## **WARNING!**

**Some dust created by power sanding, sawing, grinding, drilling, and other construction activities contains chemicals known to the State of California to cause cancer, birth defects or other reproductive harm. Some examples of these chemicals are:**

- **Lead from lead-based paints.**
- **Crystalline silica from bricks, cement and other masonry products.**
- **Arsenic and chromium from chemically-treated lumber.**

**Your risk from these exposures varies, depending on how often you do this type of work. To reduce your exposure to these chemicals: Work in a well ventilated area, and work with approved safety equipment, such as those dust masks that are specially designed to filter out microscopic particles.**

# Table of Contents

<b>INTRODUCTION</b> .....	2	<b>SECTION 5: SHOP MADE SAFETY</b>	
Manual Accuracy .....	2	<b>ACCESSORIES</b> .....	46
Contact Info.....	2	Featherboards.....	46
Machine Description .....	2	Push Sticks .....	49
Identification.....	3	Push Blocks .....	50
G0715P Machine Data Sheet.....	4	Narrow-Rip Auxiliary Fence & Push Block ..	51
<b>SECTION 1: SAFETY</b> .....	7	Outfeed & Support Tables .....	53
Safety Instructions for Machinery .....	7	Crosscut Sled.....	53
Additional Safety for Table Saws.....	9	<b>SECTION 6: AFTERMARKET ACCESSORIES</b>	
Preventing Kickback .....	10	<b>FROM GRIZZLY</b> .....	54
Protecting Yourself From Kickback.....	10	<b>SECTION 7: MAINTENANCE</b> .....	57
Glossary of Terms .....	11	Schedule .....	57
<b>SECTION 2: POWER SUPPLY</b> .....	12	Cleaning.....	57
Voltage Conversion.....	14	Unpainted Cast Iron.....	57
<b>SECTION 3: SETUP</b> .....	15	Lubrication .....	58
Needed for Setup.....	15	<b>SECTION 8: SERVICE</b> .....	59
Unpacking .....	15	Troubleshooting .....	59
Hardware Recognition Chart .....	16	Blade Tilt Stops.....	61
Inventory .....	17	Miter Slot to Blade Parallelism.....	63
Cleanup.....	19	Spreader or Riving Knife Alignment .....	66
Site Considerations.....	20	Fence Adjustments .....	67
Assembly .....	21	Miter Gauge Adjustments .....	70
Power Connection.....	24	Belt Tension & Replacement .....	71
Dust Collection.....	25	<b>SECTION 9: WIRING</b> .....	72
Test Run .....	26	Wiring Safety Instructions .....	72
Recommended Adjustments.....	26	Wiring Diagram .....	73
<b>SECTION 4: OPERATIONS</b> .....	27	Electrical Components .....	74
Operation Overview .....	27	<b>SECTION 10: PARTS</b> .....	75
Basic Controls.....	28	Body.....	75
Non-Through & Through Cuts .....	28	Trunnion.....	76
Workpiece Inspection.....	29	Power Switch .....	78
Blade Requirements .....	29	Miter Gauge .....	78
Blade Selection .....	29	Blade Guard.....	79
Blade Installation.....	31	Fence .....	80
Blade Guard Assembly .....	32	Rails .....	81
Riving Knife.....	35	Machine Labels.....	82
Ripping.....	36	<b>WARRANTY AND RETURNS</b> .....	85
Crosscutting .....	37		
Miter Cuts.....	37		
Blade Tilt/Bevel Cuts .....	38		
Dado Cutting.....	38		
Rabbet Cutting.....	41		
Resawing .....	43		

# INTRODUCTION

## Manual Accuracy

We are proud to offer this manual with your new machine! We've made every effort to be exact with the instructions, specifications, drawings, and photographs of the machine we used when writing this manual. However, sometimes we still make an occasional mistake.

Also, owing to our policy of continuous improvement, **your machine may not exactly match the manual**. If you find this to be the case, and the difference between the manual and machine leaves you in doubt, check our website for the latest manual update or call technical support for help.

Before calling, find the manufacture date of your machine by looking at the date stamped into the machine ID label (see below). This will help us determine if the manual version you received matches the manufacture date of your machine.

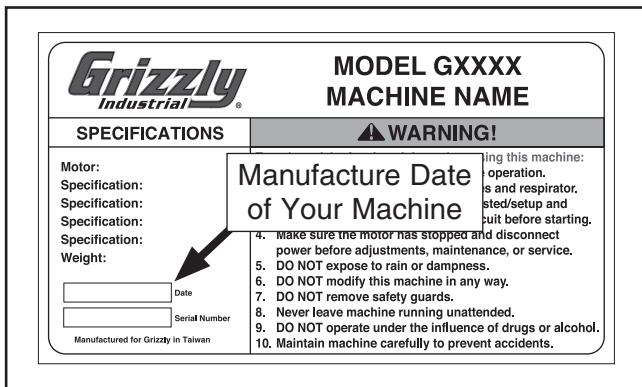

For your convenience, we post all available manuals and manual updates for free on our website at [www.grizzly.com](http://www.grizzly.com). Any updates to your model of machine will be reflected in these documents as soon as they are complete.

## Contact Info

We stand behind our machines. If you have any questions or need help, use the information below to contact us. Before contacting, please get the serial number and manufacture date of your machine. This will help us help you faster.

Grizzly Technical Support  
1203 Lycoming Mall Circle  
Muncy, PA 17756  
Phone: (570) 546-9663  
Email: [techsupport@grizzly.com](mailto:techsupport@grizzly.com)

We want your feedback on this manual. What did you like about it? Where could it be improved? Please take a few minutes to give us feedback.

Grizzly Documentation Manager  
P.O. Box 2069  
Bellingham, WA 98227-2069  
Email: [manuals@grizzly.com](mailto:manuals@grizzly.com)

## Machine Description

This hybrid table saw features a steel cabinet-type stand, cast iron trunnions, and a precision-ground cast iron table.

Cabinet-style design and collection under the blade provide highly effective dust removal, and the 2 HP motor with poly-V serpentine belts efficiently transfers power.

Includes a camlock T-shaped fence with HDPE face, miter gauge, quick-release spreader/blade guard, riving knife, and table inserts for standard and dado blades.



# Identification

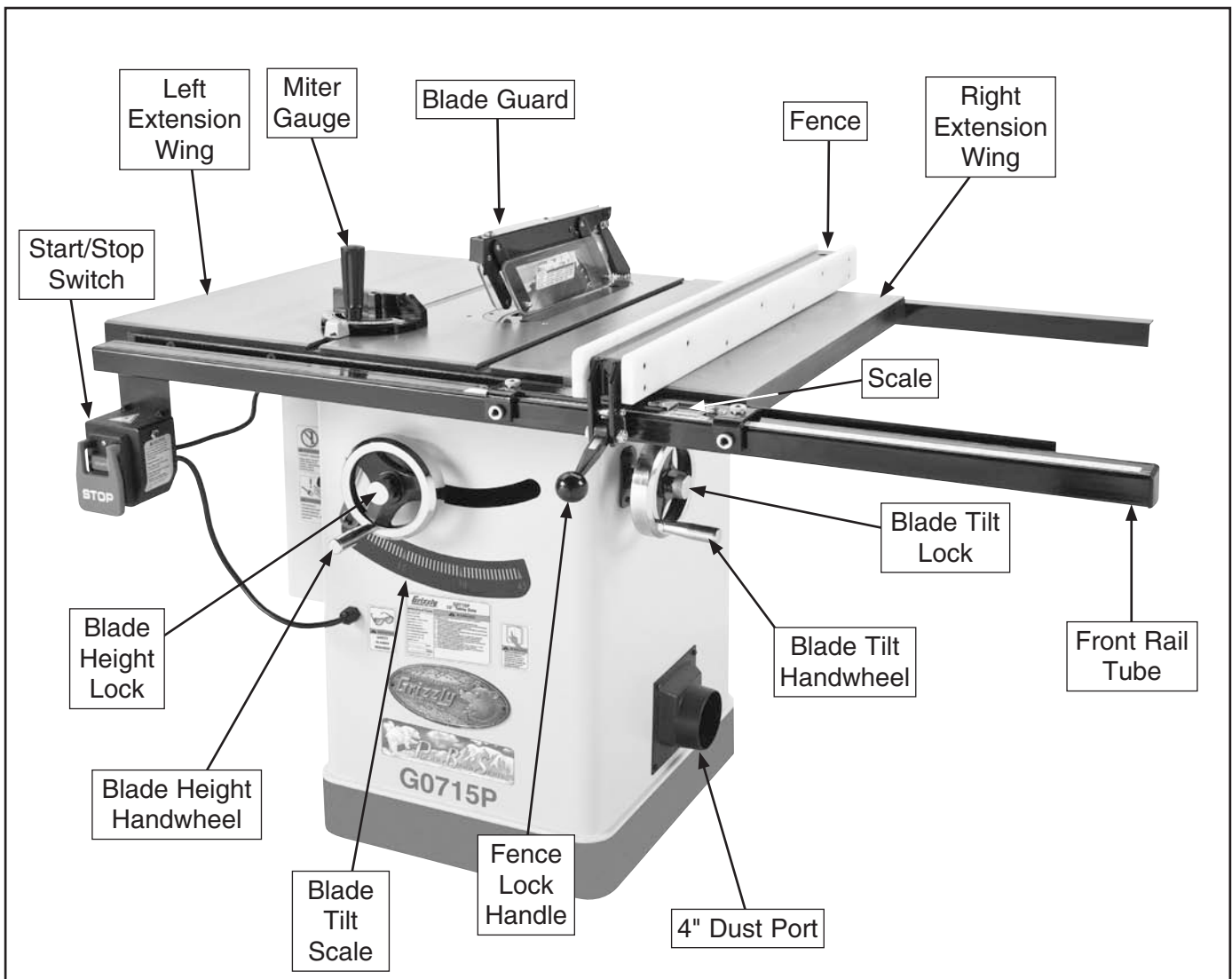

Figure 1. Model G0715P Identification of main controls and components.

## **! CAUTION**

**For Your Own Safety Read Instruction Manual Before Operating Saw**

- a) Wear eye protection.
- b) Use saw-blade guard and spreader for every operation for which it can be used, including all through sawing.
- c) Keep hands out of the line of saw blade.
- d) Use a push-stick when required.
- e) Pay particular attention to instructions on reducing risk of kickback.
- f) Do not perform any operation freehand.
- g) Never reach around or over saw blade.





# MACHINE DATA SHEET

Customer Service #: (570) 546-9663 • To Order Call: (800) 523-4777 • Fax #: (800) 438-5901

## MODEL G0715P POLAR BEAR SERIES 10" HYBRID TABLE SAW W/RIVING KNIFE

### Product Dimensions:

Weight ..... 393 lbs.  
Length/Width/Height ..... 60" x 36" x 40"  
Foot Print (Length/Width)..... 20" x 21½"

### Shipping Dimensions:

#### Carton #1

Type..... Cardboard/Wood Skids  
Content..... Machine  
Weight ..... 357 lbs.  
Length/Width/Height ..... 30" x 26" x 42"

#### Carton #2

Type..... Cardboard  
Content..... Fence  
Weight ..... 21 lbs.  
Length/Width/Height ..... 36½" x 16½" x 6½"

#### Carton #3

Type..... Cardboard  
Content..... Rails  
Weight ..... 32 lbs.  
Length/Width/Height ..... 62½" x 5" x 3½"

### Electrical:

Power Requirement ..... 110V or 220V, Single-Phase, 60 Hz  
Prewired ..... 220V  
Minimum Circuit Size ..... 20A @ 110V/20A @ 220V  
Switch..... ON/OFF Push Button with Lockout Pin  
Switch Voltage ..... 110V/220V  
Cord Length ..... 6 ft.  
Cord Gauge ..... 14 gauge  
Plug Included ..... Yes  
Included Plug Type ..... NEMA 6-20 for 220V  
Recommended Plug Type ..... NEMA 5-20 for 110V



**Motors:**

**Main**

Type.....	TEFC Capacitor Start Induction
Horsepower .....	2 HP
Voltage .....	110V/220V
Prewired .....	220V
Phase .....	Single
Amps .....	16/8A
Speed .....	3450 RPM
Cycle.....	60 Hz
Number Of Speeds.....	1
Power Transfer.....	Poly-V Serpentine Belt Drive
Bearings .....	Shielded and Permanently Sealed

**Main Specifications:**

**Blade Information**

Maximum Blade Diameter .....	10"
Riving Knife/Spreader Thickness .....	0.1" (2.5mm)
Required Blade Body Thickness .....	0.071"-0.094" (1.8-2.4mm)
Required Blade Kerf Thickness.....	0.102"-0.126" (2.6-3.2mm)
Maximum Width of Dado .....	<sup>13</sup> / <sub>16</sub> "
Blade Tilt .....	Left 0-45°
Arbor Size.....	<sup>5</sup> / <sub>8</sub> "
Arbor Speed .....	3850 RPM
Arbor Bearings .....	Sealed and Permanently Lubricated

**Cutting Capacities**

Maximum Depth of Cut at 90 Degrees.....	3 <sup>1</sup> / <sub>8</sub> "
Maximum Depth of Cut at 45 Degrees.....	2 <sup>3</sup> / <sub>16</sub> "
Maximum Rip to Right of Blade-Standard.....	30"
Maximum Rip to Left of Blade.....	12"

**Table Information**

Floor to Table Height.....	34"
Table Size Depth.....	27"
Table Size Width .....	20"
Table Size Thickness .....	1 <sup>1</sup> / <sub>2</sub> "
Table Size with Extension Wings Depth .....	27"
Table Size with Extension Wings Width.....	40"
Distance Front of Table to Center of Blade .....	16"
Distance Front of Table to Blade at Maximum Cut.....	11 <sup>1</sup> / <sub>2</sub> "

**Fence Information**

Fence Type .....	Camlock T-Shaped Fence with HDPE Face
Fence Size Length .....	34 <sup>1</sup> / <sub>4</sub> "
Fence Size Width .....	3 <sup>1</sup> / <sub>8</sub> "
Fence Size Height.....	2 <sup>1</sup> / <sub>2</sub> "
Fence Rail Type .....	Square Steel Tubing
Fence Rail Length .....	60"
Fence Rail Width.....	2"
Fence Rail Height.....	1 <sup>5</sup> / <sub>8</sub> "



**Miter Gauge Information**

Miter Gauge Slot Type ..... T-Slot  
Miter Gauge Slot Size Width ..... 3/4"  
Miter Gauge Slot Size Height..... 3/8"

**Construction**

Table Construction ..... Precision Ground Cast Iron  
Wings Construction ..... Precision Ground Cast Iron  
Trunnions Construction ..... Cast Iron  
Cabinet Construction ..... Pre-Formed Steel  
Fence Assembly Construction..... Steel with HDPE Side Plates  
Rails Construction ..... Steel  
Miter Gauge Construction ..... Aluminum  
Guard Construction ..... Steel and Clear Plastic

**Other Related Information:**

Paint ..... Powder Coated  
Number of Dust Ports ..... 1  
Dust Port Size ..... 4"  
Mobile Base ..... G7314Z

**Other Specifications:**

ISO Factory ..... ISO 9001  
Country of Origin ..... China  
Warranty ..... 1 Year  
Serial Number Location ..... ID Label on Cabinet  
Assembly Time ..... 1 Hour  
Sound Rating at Idle ..... 83 dB

**Features:**

- White powder coated paint on cabinet
- Precision ground cast iron table
- Cast iron trunnions
- 4" dust port
- T-slot miter gauge
- Camlock T-shaped fence with HDPE face
- Easy glide fence system
- Powder coated paint
- Quick release riving knife and blade guard assembly
- Knurled knobs for adjusting fence
- Includes regular as well as dado blade table inserts
- Device on blade guard allows enabling or disabling of anti-kickback pawls





# SECTION 1: SAFETY

## **WARNING**

### **For Your Own Safety, Read Instruction Manual Before Operating this Machine**

The purpose of safety symbols is to attract your attention to possible hazardous conditions. This manual uses a series of symbols and signal words intended to convey the level of importance of the safety messages. The progression of symbols is described below. Remember that safety messages by themselves do not eliminate danger and are not a substitute for proper accident prevention measures.

 **DANGER** Indicates an imminently hazardous situation which, if not avoided, **WILL** result in death or serious injury.

 **WARNING** Indicates a potentially hazardous situation which, if not avoided, **COULD** result in death or serious injury.

 **CAUTION** Indicates a potentially hazardous situation which, if not avoided, **MAY** result in minor or moderate injury. It may also be used to alert against unsafe practices.

**NOTICE** This symbol is used to alert the user to useful information about proper operation of the machine.

## **WARNING**

### **Safety Instructions for Machinery**

**OWNER'S MANUAL.** Read and understand this owner's manual **BEFORE** using machine. Untrained users can be seriously hurt.

**EYE PROTECTION.** Always wear ANSI-approved safety glasses or a face shield when operating or observing machinery to reduce the risk of eye injury or blindness from flying particles. Everyday eyeglasses are not approved safety glasses.

**HAZARDOUS DUST.** Dust created while using machinery may cause cancer, birth defects, or long-term respiratory damage. Be aware of dust hazards associated with each workpiece material, and always wear a NIOSH-approved respirator to reduce your risk.

**WEARING PROPER APPAREL.** Do not wear clothing, apparel, or jewelry that can become entangled in moving parts. Always tie back or cover long hair. Wear non-slip footwear to avoid accidental slips which could cause a loss of workpiece control.

**HEARING PROTECTION.** Always wear hearing protection when operating or observing loud machinery. Extended exposure to this noise without hearing protection can cause permanent hearing loss.

**MENTAL ALERTNESS.** Be mentally alert when running machinery. Never operate under the influence of drugs or alcohol, when tired, or when distracted.



# WARNING

**DISCONNECTING POWER SUPPLY.** Always disconnect machine from power supply before servicing, adjusting, or changing cutting tools (bits, blades, cutters, etc.). Make sure switch is in OFF position before reconnecting to avoid an unexpected or unintentional start.

**APPROVED OPERATION.** Untrained operators can be seriously hurt by machinery. Only allow trained or properly supervised people to use machine. When machine is not being used, disconnect power, remove switch keys, or lock-out machine to prevent unauthorized use—especially around children. Make workshop kid proof!

**DANGEROUS ENVIRONMENTS.** Do not use machinery in wet or rainy locations, cluttered areas, around flammables, or in poorly-lit areas. Keep work area clean, dry, and well-lighted to minimize risk of injury.

**ONLY USE AS INTENDED.** Only use machine for its intended purpose. Never modify or alter machine for a purpose not intended by the manufacturer or serious injury may result!

**USE RECOMMENDED ACCESSORIES.** Consult this owner's manual or the manufacturer for recommended accessories. Using improper accessories will increase the risk of serious injury.

**CHILDREN & BYSTANDERS.** Keep children and bystanders a safe distance away from work area. Stop using machine if children or bystanders become a distraction.

**REMOVE ADJUSTING TOOLS.** Never leave adjustment tools, chuck keys, wrenches, etc. in or on machine—especially near moving parts. Verify removal before starting!

**SECURING WORKPIECE.** When required, use clamps or vises to secure workpiece. A secured workpiece protects hands and frees both of them to operate the machine.

**FEED DIRECTION.** Unless otherwise noted, feed work against the rotation of blades or cutters. Feeding in the same direction of rotation may pull your hand into the cut.

**FORCING MACHINERY.** Do not force machine. It will do the job safer and better at the rate for which it was designed.

**GUARDS & COVERS.** Guards and covers can protect you from accidental contact with moving parts or flying debris. Make sure they are properly installed, undamaged, and working correctly before using machine.

**NEVER STAND ON MACHINE.** Serious injury or accidental contact with cutting tool may occur if machine is tipped. Machine may be damaged.

**STABLE MACHINE.** Unexpected movement during operations greatly increases the risk of injury and loss of control. Verify machines are stable/secure and mobile bases (if used) are locked before starting.

**AWKWARD POSITIONS.** Keep proper footing and balance at all times when operating machine. Do not overreach! Avoid awkward hand positions that make workpiece control difficult or increase the risk of accidental injury.

**UNATTENDED OPERATION.** Never leave machine running while unattended. Turn machine **OFF** and ensure all moving parts completely stop before walking away.

**MAINTAIN WITH CARE.** Follow all maintenance instructions and lubrication schedules to keep machine in good working condition. An improperly maintained machine may increase the risk of serious injury.

**CHECK DAMAGED PARTS.** Regularly inspect machine for damaged parts, loose bolts, mis-adjusted or mis-aligned parts, binding, or any other conditions that may affect safe operation. Always repair or replace damaged or mis-adjusted parts before operating machine.

**EXPERIENCING DIFFICULTIES.** If at any time you are experiencing difficulties performing the intended operation, stop using the machine! Contact our Technical Support Department at (570) 546-9663.



# Additional Safety for Table Saws

## **WARNING**

**HAND POSITIONING.** Never purposely touch a saw blade during operation. Always keep hands/fingers out of the blade path; place them where they cannot slip into the blade accidentally. Never reach around, behind, or over the blade. Touching a spinning saw blade will cause serious laceration or amputation injuries.

**BLADE GUARD.** Use the blade guard for all “through cuts” for which it can be used. (A through cut is an operation where the blade cuts completely through the top of the workpiece.) Make sure the blade guard is installed and adjusted correctly; promptly repair or replace it if damaged. Always re-install blade guard immediately after operations that require its removal. Operating saw with the blade guard removed greatly increases the risk of severe laceration or amputation injuries from accidental blade contact.

**RIVING KNIFE.** Use the riving knife for all “non-through cuts” for which it can be used. (A non-through cut is an operation where the blade does not cut through the top of the workpiece.) Make sure the riving knife is aligned and positioned correctly; and promptly repair or replace it if damaged. Using the riving knife incorrectly will increase the risk of kickback or accidental blade contact.

**KICKBACK.** Kickback occurs when the saw blade ejects the workpiece back toward the operator. Know how to reduce the risk of kickback, and learn how to protect yourself if it does occur.

**FEEDING WORKPIECE.** Feeding the workpiece incorrectly will increase risk of kickback. Never start the saw with a workpiece touching the blade; allow the blade to reach full speed before cutting. Only feed the workpiece against the direction of blade rotation. Always use some type of guide (fence, miter gauge, sliding table or sled, etc.) to feed the workpiece in a straight line. Never back a workpiece out of a cut or try to move it backwards or sideways after starting a cut. Feed cuts all the way through to completion. Never perform any operation “freehand” (making a cut without using a fence, miter gauge, or other guide).

**FENCE.** Make sure the fence remains properly adjusted and parallel with the blade. Always lock the fence in place before using. Using or adjusting the fence incorrectly will increase risk of kickback.

**PUSH STICKS/BLOCKS.** Use push sticks or push blocks whenever possible to keep your hands farther away from the blade while cutting; in the event of an accident these devices will often take damage that would have happened to hands/fingers.

**CUT-OFF PIECES.** Never use your hands to move cut-offs away from the blade while the saw is running. If a cut-off becomes trapped between the blade and table insert, turn the saw **OFF** and allow the blade to completely stop before removing it.

**BLADE ADJUSTMENTS.** Adjusting the blade height or tilt during operation increases the risk of crashing the blade and sending metal fragments flying with deadly force at the operator or bystanders. Only adjust the blade height and tilt when the blade is completely stopped and the saw is **OFF**.

**CHANGING BLADES.** Always disconnect power before changing blades. Changing blades while the saw is connected to power greatly increases the injury risk if saw is accidentally powered up.

**DAMAGED SAW BLADES.** Never use blades that have been dropped or otherwise damaged. Damaged blades can fly apart and strike the operator with shards of metal.

**DADO AND RABBET OPERATIONS.** DO NOT attempt dado or rabbeting operations without first reading those sections in this manual. Dado and rabbeting operations require special attention because they must be performed with the blade guard removed.

**CUTTING CORRECT MATERIAL.** Never cut materials not intended for this saw; only cut natural and man-made wood products, laminate covered wood products, and some plastics. Cutting metal, glass, stone, tile, etc. increases the risk of operator injury due to kickback or flying particles.



# Preventing Kickback

---

**Below are ways to avoid the most common causes of kickback:**

- Only cut workpieces with at least one smooth and straight edge. DO NOT cut warped, cupped or twisted wood.
- Keep the blade guard installed and working correctly for all through cuts.
- Never attempt freehand cuts. If the workpiece is not fed parallel with the blade, kickback will likely occur. Always use the rip fence or miter gauge to support the workpiece.
- Make sure the spreader or riving knife is aligned with the blade. A misaligned spreader or riving knife can cause the workpiece to catch or bind, increasing the chance of kickback.
- Take the time to check and adjust the rip fence parallel with the blade; otherwise, the chances of kickback are extreme.
- The spreader or riving knife maintains the kerf in the workpiece, reducing the chance of kickback. Always use the riving knife for all non-through operations, unless a dado blade is installed. Always use the spreader with the blade guard for all through cuts.
- Feed cuts through to completion. Anytime you stop feeding a workpiece in the middle of a cut, the chance of kickback is greatly increased.
- Keep the blade guard installed and in good working order. Only remove it when performing non-through cuts and immediately re-install the blade guard when finished. Remember, always use the riving knife for all non-through operations, unless a dado blade is installed.
- Make multiple, shallow passes when performing a non-through cut. Making a deep non-through cut will greatly increase the chance of kickback.

- Never move the workpiece backwards or try to back it out of a cut while the blade is moving. If you cannot complete a cut for some reason, stop the saw motor and allow the blade to completely stop before backing the workpiece out. Promptly fix the condition that prevented you from completing the cut before starting the saw again.

## Protecting Yourself From Kickback

---

**Even if you know how to prevent kickback, it may still happen. Here are some ways to protect yourself if kickback DOES occur:**

- Stand to the side of the blade during every cut. If kickback does occur, the thrown workpiece usually travels directly in front of the blade.
- Wear safety glasses or a face shield. In the event of kickback, your eyes and face are the most vulnerable part of your body.
- Never, for any reason, place your hand behind the blade. Should kickback occur, your hand will be pulled into the blade, which could cause amputation.
- Use a push stick to keep your hands farther away from the moving blade. If kickback occurs, the push stick will most likely take the damage your hand would have received.
- Use featherboards or anti-kickback devices to assist with feeding and prevent or slow down kickback.

### CAUTION

**Statistics show that most common accidents among table saw users can be linked to kickback. Kickback is typically defined as the high-speed expulsion of stock from the table saw toward its operator. In addition to the danger of the operator or others in the area being struck by the flying stock, it is often the case that the operator's hands are pulled into the blade during kickback.**



# Glossary of Terms

---

---

The following is a list of common definitions, terms and phrases used throughout this manual as they relate to this table saw and woodworking in general. Become familiar with these terms for assembling, adjusting or operating this machine. Your safety is **VERY** important to us at Grizzly!

**Arbor:** A metal shaft extending from the drive mechanism that is the mounting location for the saw blade.

**Bevel Edge Cut:** A cut made with the blade tilted to an angle between 0° and 45° to cut a beveled edge onto a workpiece. Refer to **Page 38** for more details.

**Blade Guard Assembly:** Metal or plastic safety device that mounts over the saw blade. Its function is to prevent the operator from coming into contact with the saw blade. Refer to **Page 32** for more details.

**Crosscut:** Cutting operation in which the cross-cut fence is used to cut across the shortest width of the workpiece. Refer to **Page 37** for more details.

**Dado Blade:** Blade or set of blades that are used to cut grooves and rabbets. Refer to **Page 38** for more details. The saw and arbor are not intended to safely use a larger dado blade.

**Dado Cut:** Cutting operation that uses a dado blade to cut a flat bottomed groove into the face of the workpiece. Refer to **Page 38** for more details.

**Featherboard:** Safety device used to keep the workpiece against the rip fence and against the table surface. Refer to **Page 46** for more details.

**Kerf:** The resulting cut or gap in the workpiece after the saw blade passes through during a cutting operation.

**Kickback:** An event in which the workpiece is propelled back towards the operator at a high rate of speed.

**Non-Through Cut:** A cut in which the blade does not cut through the top of the workpiece. Refer to **Page 28** for more details.

**Parallel:** Being an equal distance apart at every point along two given lines or planes (i.e. the rip fence face is parallel to the face of the saw blade).

**Perpendicular:** Lines or planes that intersect and form right angles (i.e. the blade is perpendicular to the table surface).

**Push Stick:** Safety device used to push the workpiece through a cutting operation. Used most often when rip cutting thin workpieces. Refer to **Page 49** for more details.

**Rabbet:** Cutting operation that creates an L-shaped channel along the edge of the workpiece. Refer to **Page 41** for more details.

**Rip Cut:** Cutting operation in which the rip fence is used to cut across the widest width of the workpiece. Refer to **Page 36** for more details.

**Riving Knife:** Metal plate located behind the blade. It maintains the kerf opening in the wood when performing a cutting operation. Refer to **Page 35** for more details.

**Straightedge:** A tool used to check the flatness, parallelism, or consistency of a surface(s).

**Thin Kerf Blade:** A blade with a kerf or thickness that is thinner than a standard blade cannot be used on this saw.

**Through Cut:** A cut in which the blade cuts completely through the workpiece. Refer to **Page 28** for more details.



# SECTION 2: POWER SUPPLY

## Availability

Before installing the machine, consider the availability and proximity of the required power supply circuit. If an existing circuit does not meet the requirements for this machine, a new circuit must be installed. To minimize the risk of electrocution, fire, or equipment damage, installation work and electrical wiring must be done by a qualified electrician in accordance with all applicable codes and standards.

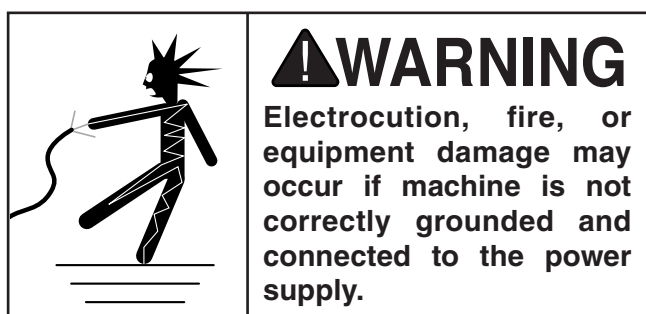

## Full-Load Current Rating

The full-load current rating is the amperage a machine draws at 100% of the rated output power. On machines with multiple motors, this is the amperage drawn by the largest motor or sum of all motors and electrical devices that might operate at one time during normal operations.

**Full-Load Current Rating at 220V ..... 8 Amps**

**Full-Load Current Rating at 110V..... 16 Amps**

The full-load current is not the maximum amount of amps that the machine will draw. If the machine is overloaded, it will draw additional amps beyond the full-load rating.

If the machine is overloaded for a sufficient length of time, damage, overheating, or fire may result—especially if connected to an undersized circuit. To reduce the risk of these hazards, avoid overloading the machine during operation and make sure it is connected to a power supply circuit that meets the requirements in the following section.

## Circuit Information

A power supply circuit includes all electrical equipment between the breaker box or fuse panel in the building and the machine. The power supply circuit used for this machine must be sized to safely handle the full-load current drawn from the machine for an extended period of time. (If this machine is connected to a circuit protected by fuses, use a time delay fuse marked D.)



**Note:** *The circuit requirements listed in this manual apply to a dedicated circuit—where only one machine will be running at a time. If this machine will be connected to a shared circuit where multiple machines will be running at the same time, consult a qualified electrician to ensure that the circuit is properly sized for safe operation.*

## Circuit Requirements for 220V

This machine is prewired to operate on a 220V power supply circuit that has a verified ground and meets the following requirements:

**Nominal Voltage ..... 220V/240V**  
**Cycle.....60 Hz**  
**Phase..... Single-Phase**  
**Circuit Rating..... 20 Amps**  
**Plug/Receptacle ..... NEMA 6-20**

## Circuit Requirements for 110V

This machine can be converted to operate on a 110V power supply (refer to **Voltage Conversion** instructions) that has a verified ground and meets the following requirements:

**Nominal Voltage ..... 110V/120V**  
**Cycle.....60 Hz**  
**Phase..... Single-Phase**  
**Circuit Rating..... 20 Amps**  
**Plug/Receptacle ..... NEMA 5-20**



## Grounding Requirements

This machine **MUST** be grounded. In the event of certain malfunctions or breakdowns, grounding reduces the risk of electric shock by providing a path of least resistance for electric current.

**For 220V operation:** This machine is equipped with a power cord that has an equipment-grounding wire and a grounding plug (see following figure). The plug must only be inserted into a matching receptacle (outlet) that is properly installed and grounded in accordance with all local codes and ordinances.

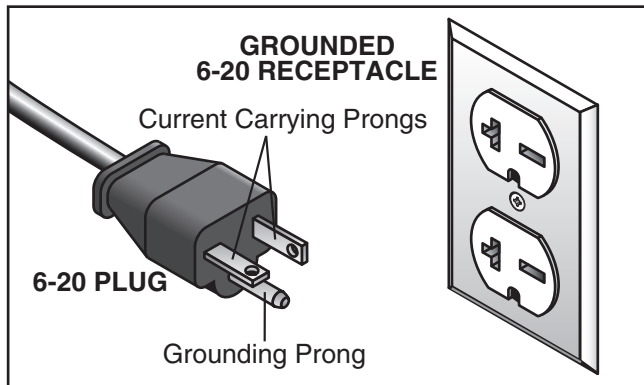

**Figure 2.** Typical 6-20 plug and receptacle.

**For 110V operation:** The plug specified under “Circuit Requirements for 110V” on the previous page has a grounding prong that must be attached to the equipment-grounding wire inside the included power cord. The plug must only be inserted into a matching receptacle (see below) that is properly installed and grounded in accordance with all local codes and ordinances.

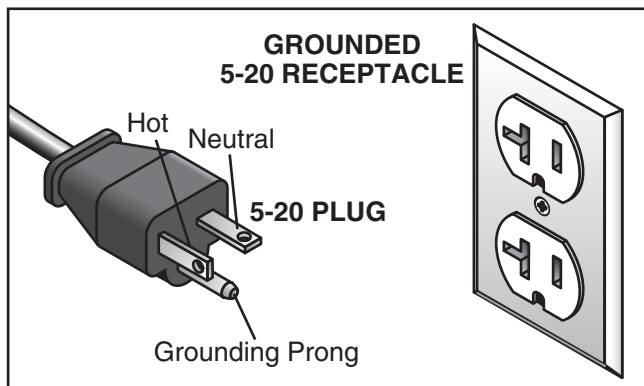

**Figure 3.** Typical 5-20 plug and receptacle.

## **!WARNING**

**Serious injury could occur if you connect the machine to power before completing the setup process. DO NOT connect to power until instructed later in this manual.**

Improper connection of the equipment-grounding wire can result in a risk of electric shock. The wire with green insulation (with or without yellow stripes) is the equipment-grounding wire. If repair or replacement of the power cord or plug is necessary, do not connect the equipment-grounding wire to a live (current carrying) terminal.

Check with a qualified electrician or service personnel if you do not understand these grounding requirements, or if you are in doubt about whether the tool is properly grounded. If you ever notice that a cord or plug is damaged or worn, disconnect it from power, and immediately replace it with a new one.

## Extension Cords

We do not recommend using an extension cord with this machine. If you must use an extension cord, only use it if absolutely necessary and only on a temporary basis.

Extension cords cause voltage drop, which may damage electrical components and shorten motor life. Voltage drop increases as the extension cord size gets longer and the gauge size gets smaller (higher gauge numbers indicate smaller sizes).

Any extension cord used with this machine must contain a ground wire, match the required plug and receptacle, and meet the following requirements:

**Minimum Gauge Size .....12 AWG**  
**Maximum Length (Shorter is Better).....50 ft.**



# Voltage Conversion

This section shows how to convert the Model G0715P from 220V to 110V. The plug needed for this conversion can be purchased at any local hardware store or electrical supply store. The circuit breaker must be purchased from Grizzly.

Items Needed	Qty
• Phillips Head Screwdriver #2 .....	1
• NEMA 5-20 Plug.....	1
• Circuit Breaker 20A (P0715P204-1).....	1

## NOTICE

This manual was current at the time of printing; however, if the wiring diagram provided on the inside cover of the motor junction box conflicts with this manual, always use that wiring diagram instead, as it will accurately reflect any changes that may have occurred after printing.

### Converting G0715P to 110V

1. DISCONNECT SAW FROM POWER!
2. Cut off the pre-installed 6-20 plug from the end of the power cord.
3. Open the motor junction box, then loosen the screws indicated in **Figure 4**.

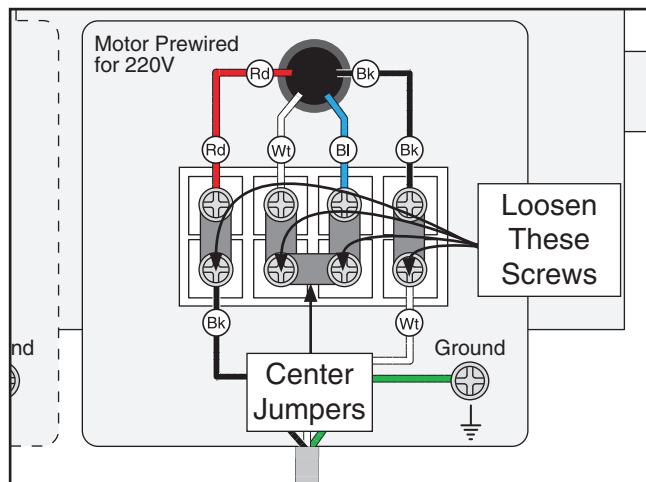

**Figure 4.** Location of screws to be loosened.

4. Remove the two center jumpers (they are stacked together), reposition them as shown in **Figure 5**, then tighten the four screws loosened in **Step 2**.

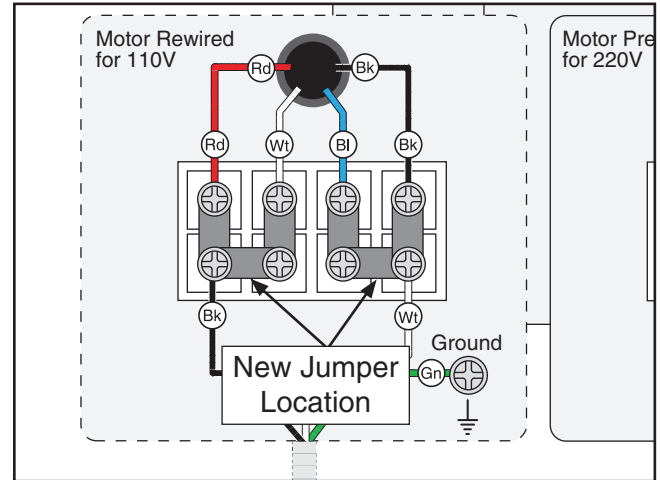

**Figure 5.** Relocated jumpers.

5. Close and secure the motor junction box.
6. Remove the start/stop switch box from the switch mounting plate.
7. Replace the pre-installed 10 amp circuit breaker (see **Figure 6**) with a 20 amp circuit breaker (part #P0715P204-1), then re-install the start/stop switch.

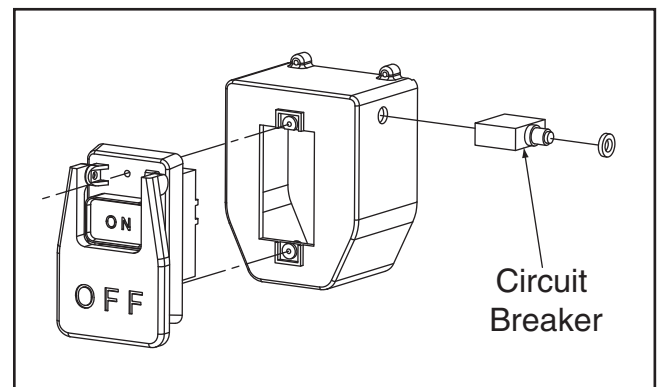

**Figure 6.** Location of circuit breaker.

8. Install a 5-20 plug on the end of the cord, according to the instructions and wiring diagrams provided by the plug manufacturer.

—If the plug manufacturer did not include instructions, the wiring of a generic NEMA 5-20 plug is illustrated in the **Wiring** section, starting on **Page 72**.





# SECTION 3: SETUP

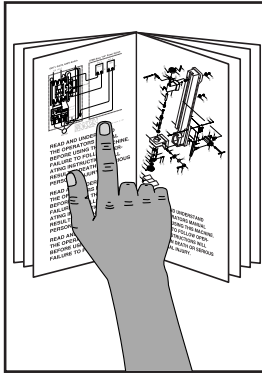

**⚠ CAUTION**  
 This machine presents serious injury hazards to untrained users. Read through this entire manual to become familiar with the controls and operations before starting the machine!



**⚠ CAUTION**  
 Wear safety glasses during the entire setup process!

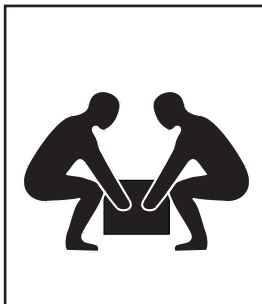

**⚠ CAUTION**  
 This machine and its components are very heavy. Get lifting help or use power lifting equipment such as a forklift to move heavy items.

## Needed for Setup

The following are needed to complete the setup process, but are not included with the machine:

Description	Qty
• Safety Glasses for Each Person .....	1
• Degreaser or Solvent for Cleaning.....	Varies
• Rags for Cleaning.....	Varies
• Straightedge .....	1
• Level .....	1
• Dust Collection System .....	1
• 4" Dust Hose .....	1
• 4" Hose Clamp .....	1
• Another Person for Lifting .....	1
• Needle Nose Pliers .....	1
• Wrench or Socket 17mm .....	1
• Wrench or Socket 14mm .....	1
• Wrench or Socket 10mm.....	1
• Adjustable Wrench .....	1

## Unpacking

Your machine was carefully packaged for safe transportation. Remove the packaging materials from around your machine and inspect it. If you discover any damage, *please call us immediately at (570) 546-9663 for advice.*

Save the containers and all packing materials for possible inspection by the carrier or its agent. *Otherwise, filing a freight claim can be difficult.*

When you are completely satisfied with the condition of your shipment, inventory the contents.



**⚠ WARNING**  
**SUFFOCATION HAZARD!**  
 Keep children and pets away from plastic bags or packing materials unpacked with this machine. Discard immediately.



# Hardware Recognition Chart

USE THIS CHART TO MATCH UP HARDWARE DURING THE ASSEMBLY PROCESS.

MEASURE BOLT DIAMETER BY PLACING INSIDE CIRCLE

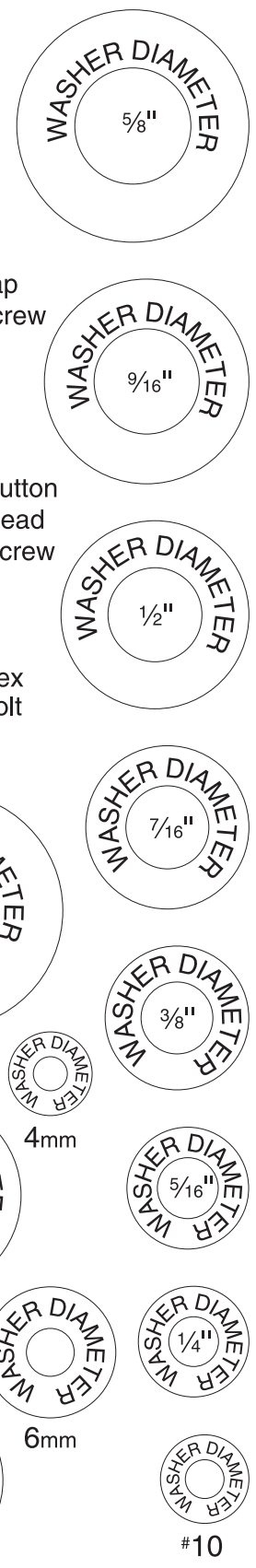
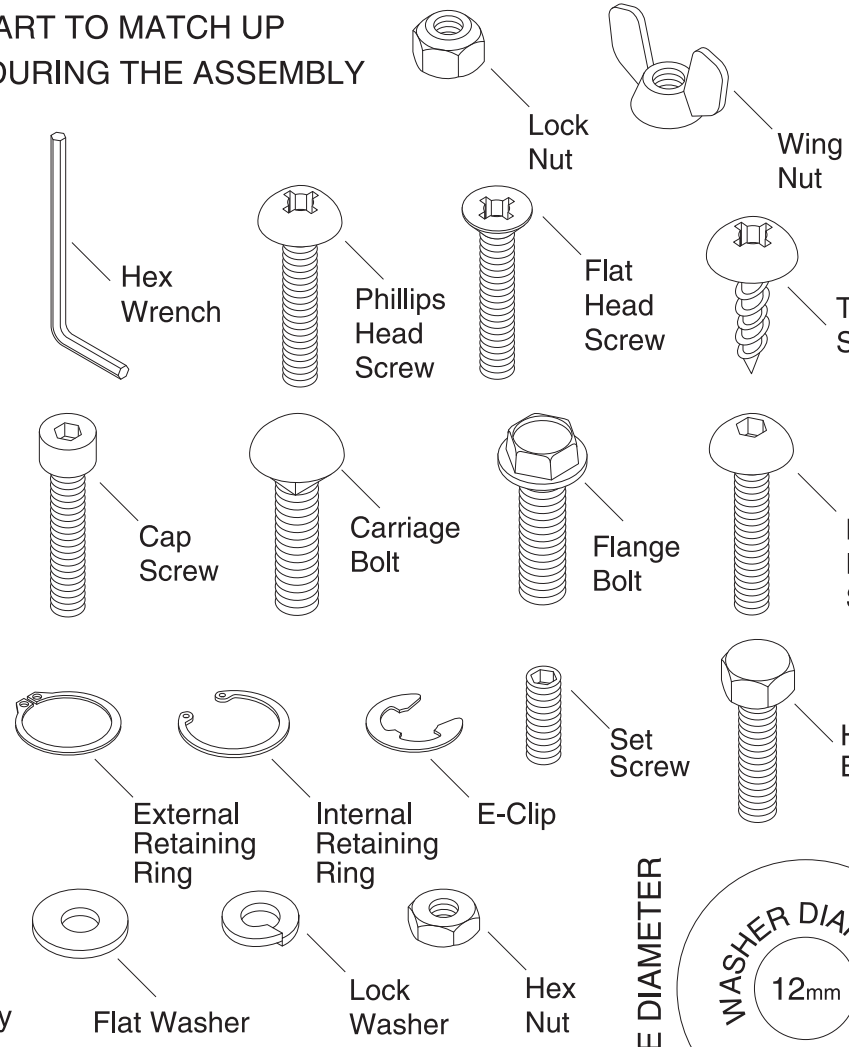
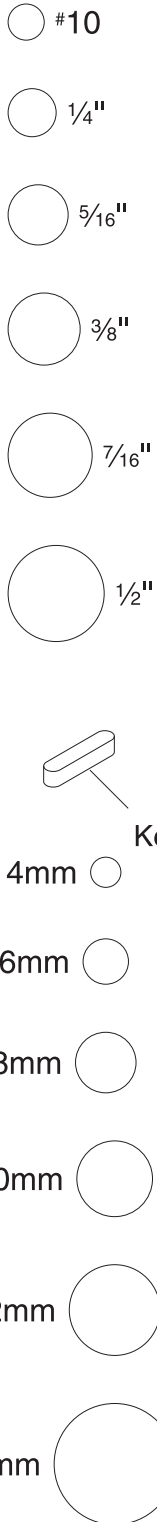

WASHERS ARE MEASURED BY THE INSIDE DIAMETER



# Inventory

The following is a description of the main components shipped with each Model G0715P. Lay the components out to inventory them.

**Note:** *If you can't find an item on this list, check the mounting location on the machine or examine the packaging materials carefully. Occasionally we pre-install certain components for shipping purposes.*

If any nonproprietary parts are missing (e.g. a nut or a washer), we will gladly replace them; or for the sake of expediency, replacements can be obtained at your local hardware store.



**Figure 7.** Main table saw unit.

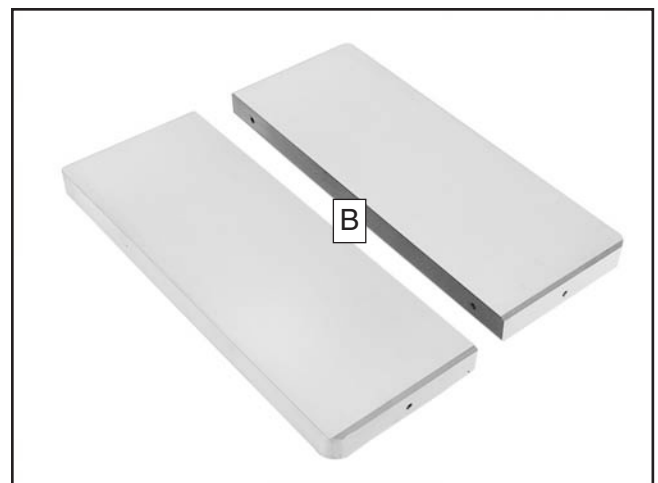

**Figure 8.** Extension wings.

<b>Box Contents: (Figures 7–9)</b>	<b>Qty</b>
<b>A.</b> Main Table Saw Unit .....	1
<b>B.</b> Extension Wings .....	2
<b>C.</b> Saw Blade 10" x 40T .....	1
<b>D.</b> Wrench 7/16"/13mm .....	1
<b>E.</b> Arbor Wrench 24mm .....	1
<b>F.</b> Motor Door .....	1
<b>G.</b> Blade Guard Assembly .....	1
<b>H.</b> Riving Knife .....	1
<b>I.</b> Push Stick .....	1
<b>J.</b> Handwheel Handles .....	2
<b>K.</b> Miter Gauge.....	1
<b>L.</b> Hex Wrench 6-Piece Set 2.5-8mm .....	1
<b>M.</b> Dado Table Insert.....	1

<b>Hardware (Not Shown)</b>	<b>Qty</b>
Cap Screw M5-.8 x 12 (Mag Switch) .....	2
Lock Washers 5mm (Mag Switch).....	2
Flat Washers 5mm (Mag Switch) .....	2

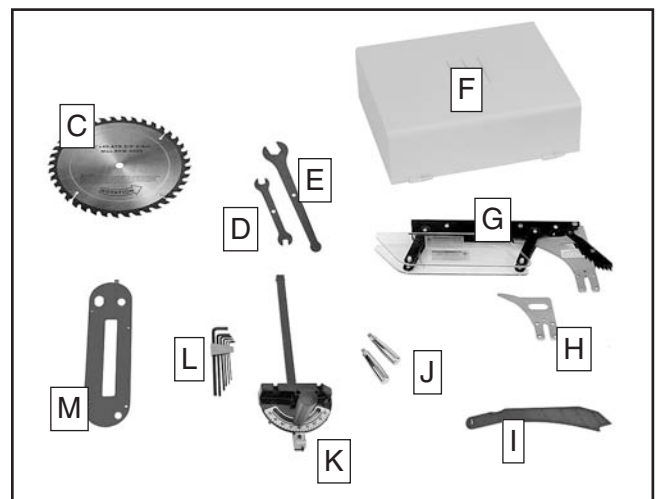

**Figure 9.** Component inventory.



<b>Components</b>	<b>Qty</b>
<b>N.</b> Front Rail Tube 58".....	1
<b>O.</b> Front Rail Tape Scale.....	1
<b>P.</b> Rear Rail 53" (4-Holes) .....	1
<b>Q.</b> Front Rail 53" (10-Holes) .....	1
<b>R.</b> Fence Assembly.....	1

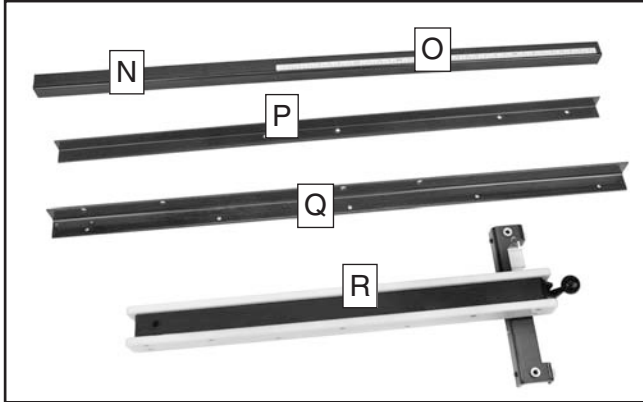

**Figure 10.** Inventory needed to install the fence on the Model G0715P.

<b>Hardware and Tools (Not Shown)</b>	<b>Qty</b>
Flat Hd Screws M8-1.25 x 35 (Front Rail/Table)	4
Flat Washers 8mm (Front Rail/Table).....	4
Lock Washers 8mm (Front Rail/Table).....	4
Hex Nuts M8-1.25 (Front Rail/Table) .....	4
Cap Screws M6-1 x 16 (Front Rail/Tube) .....	5
Flat Washers 6mm (Front Rail/Tube) .....	5
Lock Washers (Front Rail/Tube).....	5
Cap Screws M10-1.5 x 25 (Rear Rail/Table) .....	2
Flat Washers 10mm (Rear Rail/Table) .....	2
Lock Washers 10mm (Rear Rail/Table).....	2
Cap Screws M8-1.25 x 35 (Rear Rail/Wing) .....	2
Hex Nuts M8-1.25 (Rear Rail/Wing) .....	2
Flat Washers 8mm (Rear Rail/Wing).....	2
Lock Washers 8mm (Rear Rail/Wing).....	2



# Cleanup

---

The unpainted surfaces of your machine are coated with a heavy-duty rust preventative that prevents corrosion during shipment and storage. This rust preventative works extremely well, but it will take a little time to clean.

Be patient and do a thorough job cleaning your machine. The time you spend doing this now will give you a better appreciation for the proper care of your machine's unpainted surfaces.

There are many ways to remove this rust preventative, but the following steps work well in a wide variety of situations. Always follow the manufacturer's instructions with any cleaning product you use and make sure you work in a well-ventilated area to minimize exposure to toxic fumes.

## Before cleaning, gather the following:

- Disposable Rags
- Cleaner/degreaser (WD•40 works well)
- Safety glasses & disposable gloves
- Plastic paint scraper (optional)

## Basic steps for removing rust preventative:

1. Put on safety glasses.
2. Coat the rust preventative with a liberal amount of cleaner/degreaser, then let it soak for 5–10 minutes.
3. Wipe off the surfaces. If your cleaner/degreaser is effective, the rust preventative will wipe off easily. If you have a plastic paint scraper, scrape off as much as you can first, then wipe off the rest with the rag.
4. Repeat **Steps 2–3** as necessary until clean, then coat all unpainted surfaces with a quality metal protectant to prevent rust.

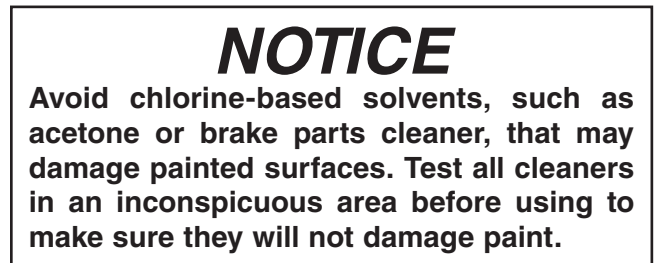
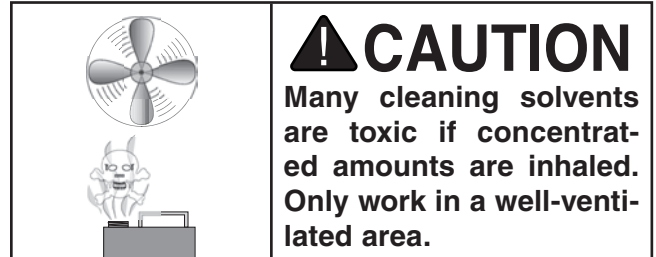
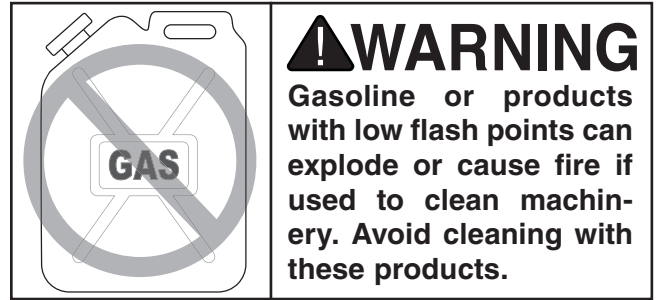

# Site Considerations

## Weight Load

Refer to the **Machine Data Sheet** for the weight of your machine. Make sure that the surface upon which the machine is placed will bear the weight of the machine, additional equipment that may be installed on the machine, and the heaviest workpiece that will be used. Additionally, consider the weight of the operator and any dynamic loading that may occur when operating the machine.

## Space Allocation

Consider the largest size of workpiece that will be processed through this machine and provide enough space around the machine for adequate operator material handling or the installation of auxiliary equipment. With permanent installations, leave enough space around the machine to open or remove doors/covers as required by the maintenance and service described in this manual. **See below for required space allocation.**

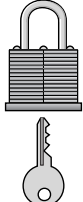
	<p><b>CAUTION</b> Children or untrained people may be seriously injured by this machine. Only install in an access restricted location.</p>
---	---

## Physical Environment

The physical environment where your machine is operated is important for safe operation and the longevity of its components. For best results, operate this machine in a dry environment that is free from excessive moisture, hazardous chemicals, airborne abrasives, or extreme conditions. Extreme conditions for this type of machinery are generally those where the ambient temperature range exceeds 41°–104°F; the relative humidity range exceeds 20–95% (non-condensing); or the environment is subject to vibration, shocks, or bumps.

## Electrical Installation

Place this machine near an existing power source. Make sure all power cords are protected from traffic, material handling, moisture, chemicals, or other hazards. Make sure to leave access to a means of disconnecting the power source or engaging a lockout/tagout device.

## Lighting

Lighting around the machine must be adequate enough that operations can be performed safely. Shadows, glare, or strobe effects that may distract or impede the operator must be eliminated.

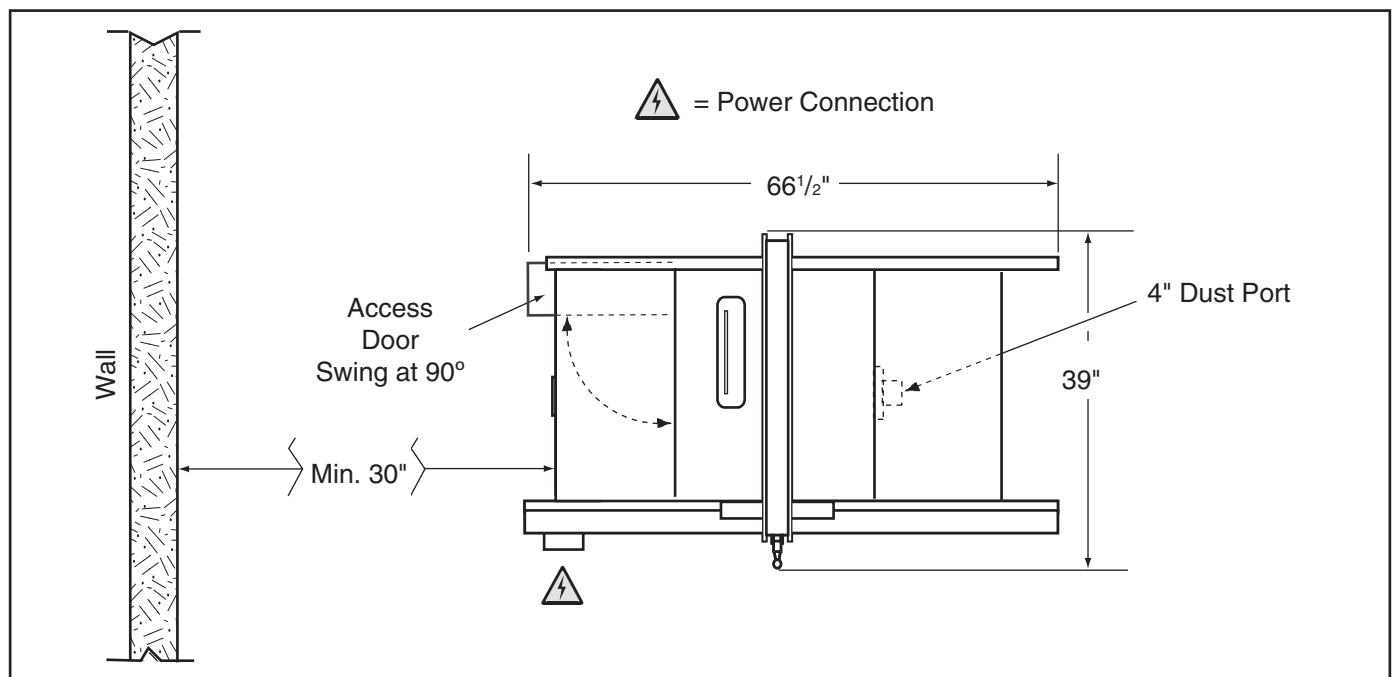

# Assembly

Assembly consists of installing minor components, the extension wings, fence rails, fence, and blade guard.

## To assemble the table saw:

1. Remove the shipping brace (see **Figure 12**), and reinstall the fasteners. Save the shipping brace for later machine transport.



**Figure 12.** Shipping brace location.

2. Pull the magnetic switch out of the saw cabinet, and install the door by inserting the door pins into the hinge sockets on the cabinet (see **Figure 13**).



**Figure 13.** Door installed.

3. Before closing the door, thoroughly clean the heavy-duty rust preventative off of the gearing inside the saw and coat these with the appropriate metal protectant (refer to **Lubrication** on **Page 58** for the location of gears).

4. Thread each of the handles onto the handwheels, then tighten them with a 14mm wrench (see **Figure 14**).

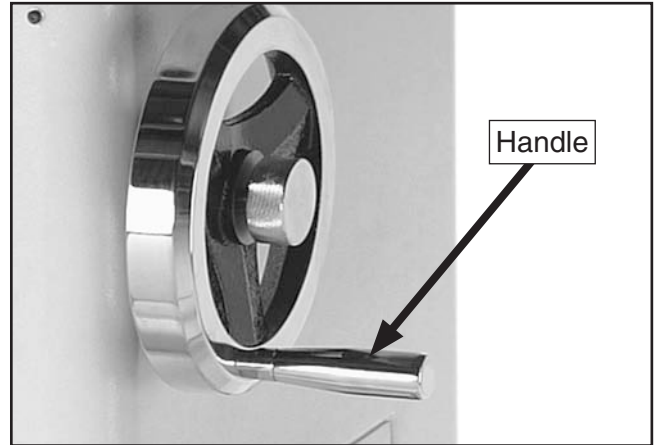

**Figure 14.** Handwheel installed.

5. Remove the six cap screws, flat washers, and lock washers from both sides of the main table.
6. Inspect the extension wings and main table mating surfaces for burrs or foreign materials that may inhibit assembly.

For a correct fit, the mating edges of the table and wings must be clean, smooth, and flat. If necessary, use a wire brush or file to remove any flashing, dings, or high spots.

7. While a helper holds the wings in place, attach each extension wing to the main table with the three M10-1.5 x 25 cap screws, 10mm lock washers, and 10mm flat washers removed in **Step 5** (see **Figure 15**).



**Figure 15.** Extension wings installed.



- Place a straightedge across the extension wings and main table to make sure that the combined table surface is flat.

—If the combined table surface is flat, skip to the next step.

—If the outside end of the extension wing tilts down, place a strip of masking tape along the bottom edge of the main table to shim the end of the extension wing up (see **Figure 16**).

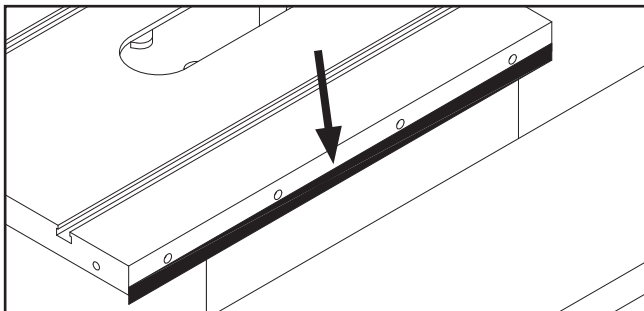

**Figure 16.** Masking tape location for tilting the extension wing up.

—If the outside end of the extension wing tilts up, place a strip of masking tape along the top edge of the main table to shim the end of the extension wing down (see **Figure 17**).

**Note:** After reinstalling wings, remove all excess masking tape with a razor blade.

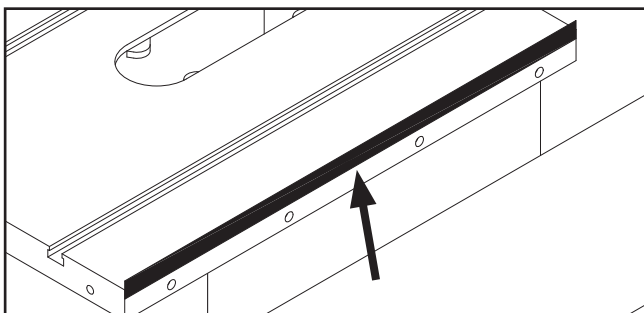

**Figure 17.** Masking tape location for adjusting the extension wing down.

- Attach the front rail to the table and extension wings with four M8-1.25 x 35 flat head screws, 8mm flat washers, 8mm lock washers, and M8-1.25 hex nuts, as shown in **Figure 18**. Make sure the top of the rail is parallel with the table top before fully tightening the fasteners.

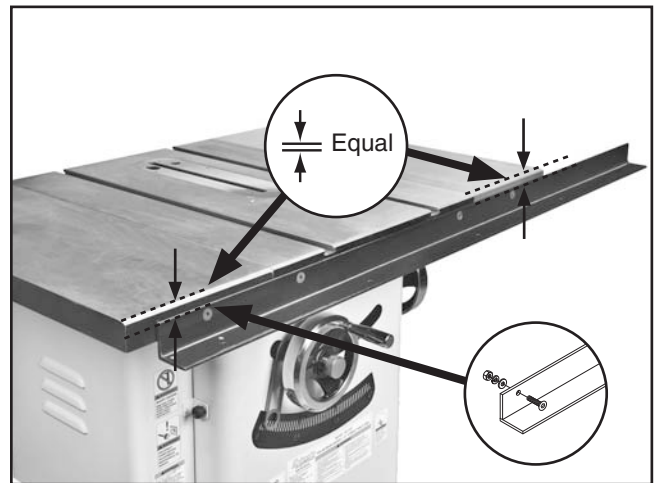

**Figure 18.** Front rail installed.

- Install the front rail tube onto the front rail with the five M6-1 x 16 cap screws, 6mm flat washers, and 6mm lock washers, as shown in **Figure 19**. Finger tighten the fasteners.



**Figure 19.** Rectangular tube attached to front rail.

- While standing at the front of the table, pull the rail tube toward you as far as possible, then final tighten the fasteners installed in **Step 10**. This will help make sure there is enough room for the fence to slide.





- Attach the rear rail to the holes on the main table using two M10-1.5 x 25 cap screws, 10mm lock washers, and 10mm flat washers, as shown in **Figure 20**. Check to make sure the rear rail is parallel to the table and below the miter slots before completely tightening the cap screws.

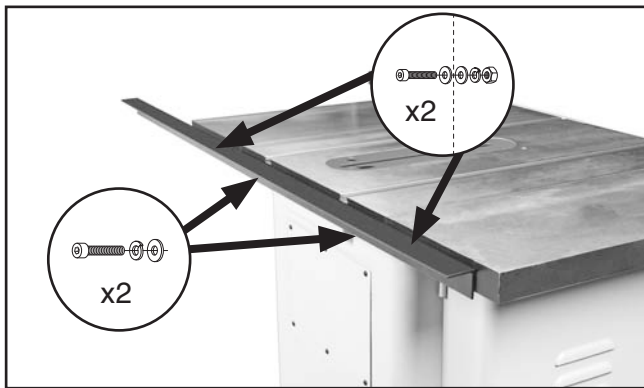

**Figure 20.** Rear rail installed.

- Secure the rear rail to the extension wings with two M8-1.25 x 35 cap screws, four 8mm flat washers, two 8mm lock washers, and two M8-1.25 hex nuts.
- Install the saw blade as outlined in **Blade Installation** on **Page 31**.
- Place the fence on the rails (on the right hand side of the blade, as shown in **Figure 21**).

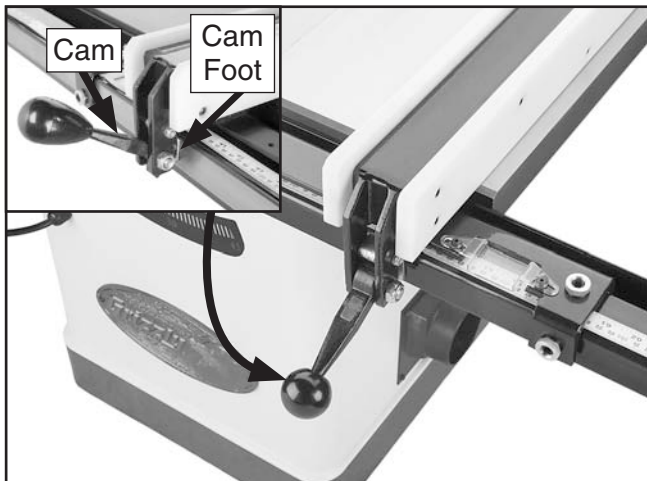
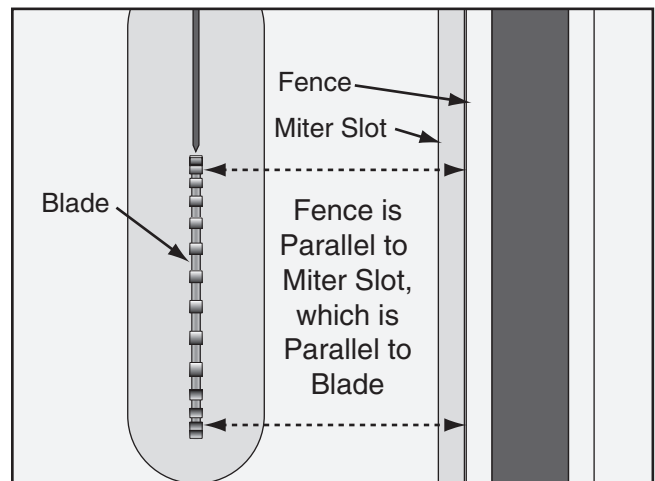

**Figure 21.** Fence installed on rails.

**Note:** Make sure the cam foot contacts the cam on the fence lock handle before you place the fence on the rail; otherwise, the fence will not lock onto the rail tube.

- Adjust the foot at the rear of the fence so that the gap between the fence and the table top is even from front to back.
- Slide the fence up against the right hand edge of the miter slot, and lock it in place. Examine how the fence lines up with the miter slot.

**Note:** It is permissible for the back of the fence to pivot outward not more than  $\frac{1}{64}$ " from being parallel with the miter slot. This creates a slightly larger opening between the fence and the blade, at the rear of the blade, to reduce the risk of workpiece binding or burning as it is fed through the cut. Many woodworkers intentionally set up their fence in this manner. Keep this in mind before adjusting your fence. For more details, see **Figure 117** on **Page 69**.



**Figure 22.** Checking fence parallelism with blade.

- If the fence is still parallel with the miter slot, proceed to **Step 18**.
- If the fence is not parallel with the miter slot, then you **MUST** adjust the fence, as described in **Fence Adjustments** on **Page 67**, so that it is parallel.
- If the miter slot is not parallel with the blade, you must follow the procedures described in **Miter Slot to Blade Parallelism** on **Page 63**.



18. Carefully slide the fence so it barely touches the saw blade and lock it in place.
19. Lightly mark the "0" location on the fence tube with a pencil, then remove the fence.
20. Peel the tape, carefully align the "0" mark on the scale with the pencil mark you made on the fence tube, and make sure the tape is parallel to the fence tube along its length.
21. Re-install the fence, move it over to just touch the blade, and verify that the indicator line is directly over the "0" mark.

—If you need to correct the position of the indicator line, loosen the screws on the pointer window, adjust the pointer window so the line is over the 0" mark on the tape (see **Figure 23**), then secure the screws.

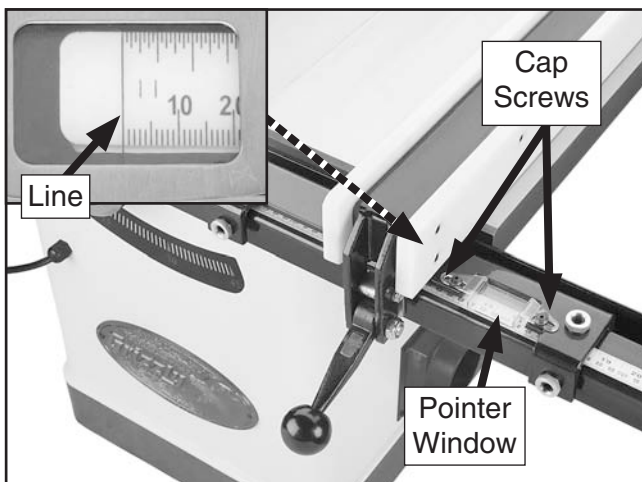

**Figure 23.** Aligning rail tape with scale pointer.

22. Install the blade guard as outlined on **Page 32**.

23. Attach the magnetic switch to the bottom left-hand side of the front rail using two M5-.8 x 12 cap screws, 5mm lock washers, and 5mm flat washers, as shown in **Figure 24**.

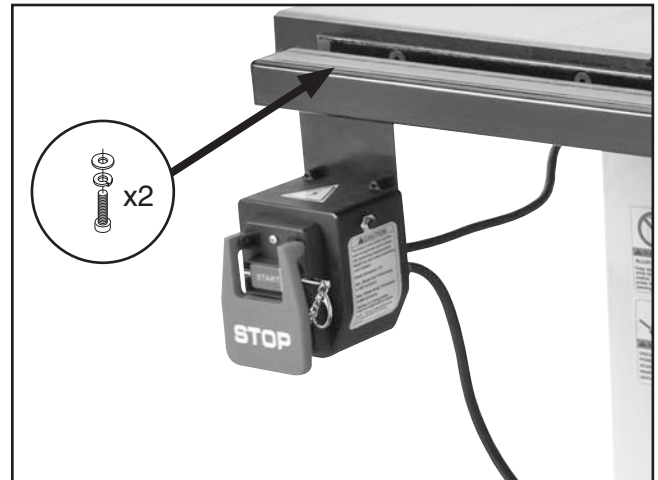

**Figure 24.** Magnetic switch installed.

## Power Connection

Before the machine can be connected to the power source, an electrical circuit must be made available that meets the minimum specifications given in the "Circuit Requirements" on **Page 12**. If a power circuit has not been prepared for the machine, do that now. To ensure a safe and code-compliant setup, we strongly recommend that all electrical work be done by a qualified electrician.

### To connect to the power supply:

1. Make sure all previous assembly and setup instructions in this manual have been completed.
2. Clear away all tools and objects used during setup from the machine.
3. Insert the plug into a matching receptacle.



# Dust Collection

## **⚠ CAUTION**

**DO NOT** operate the Model G0715P without an adequate dust collection system. This saw creates substantial amounts of wood dust while operating. Failure to use a dust collection system can result in short and long-term respiratory illness.

Components and Hardware Needed:	Qty
Dust Hose 4" (not included) .....	1
Hose Clamps 4" (not included) .....	2
Dust Collection System (not included) .....	1

### **Recommended CFM at Dust Port: 400 CFM**

*Do not confuse this CFM recommendation with the rating of the dust collector. To determine the CFM at the dust port, you must consider these variables: (1) CFM rating of the dust collector, (2) hose type and length between the dust collector and the machine, (3) number of branches or wyes, and (4) amount of other open lines throughout the system. Explaining how to calculate these variables is beyond the scope of this manual. Consult an expert or purchase a good dust collection "how-to" book.*

### To connect a dust collection hose:

1. Fit a 4" dust hose over the dust port, as shown in **Figure 25**, and tightly secure it in place with a hose clamp.
2. Tug the hose to make sure it does not come off. **Note:** A tight fit is necessary for proper performance.



**Figure 25.** Dust hose attached to dust port.



# Test Run

---

Once the assembly is complete, test run your machine to make sure it runs properly and is ready for regular operation.

The test run consists of verifying the following:  
1) The motor powers up and runs correctly, and  
2) the safety disabling mechanism on the switch works correctly.

If, during the test run, you cannot easily locate the source of an unusual noise or vibration, stop using the machine immediately, then review **Troubleshooting** on **Page 59**. If you still cannot remedy a problem, contact our Tech Support at (570) 546-9663 for assistance.

## To test run the machine:

1. Make sure you have read the safety instructions at the beginning of the manual and that the machine is set up properly.
2. Make sure the machine has been connected to the power, as described in **Power Connection** on **Page 24**.
3. Verify that the machine is operating correctly by turning the machine **ON**.
  - When operating correctly, the machine runs smoothly with little or no vibration or rubbing noises.
  - Investigate and correct strange or unusual noises or vibrations before operating the machine further. Always disconnect the machine from power when investigating or correcting potential problems.
4. Turn the machine **OFF**.
5. Insert the switch disabling pin through the green START button, as shown in **Figure 26**.

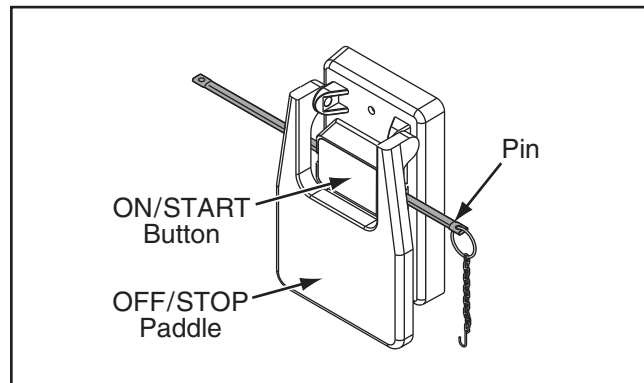

**Figure 26.** Example of switch disabling pin inserted into START button.

6. Press the green START button to test the disabling feature on the switch.
  - If the machine does not start, the switch disabling feature is working as designed.
  - If the machine starts, immediately stop the machine. The switch disabling feature is not working correctly. This safety feature must work properly before proceeding with regular operations. Call Tech Support for help.

---

## Recommended Adjustments

---

For your convenience, the adjustments listed below have been performed at the factory and no further setup is required to operate this machine. However, because of the many variables involved with shipping, we recommend that you verify the following adjustments to ensure that this saw cuts safely and accurately.

Step-by-step instructions for these adjustments can be found in **SECTION 7: SERVICE**.

### Adjustments that should be verified:

1. Blade Tilt Stop Accuracy (**Page 61**).
2. Miter Slot Parallel to Blade (**Page 63**).
3. Spreader/Riving Knife Alignment (**Page 66**).



# SECTION 4: OPERATIONS

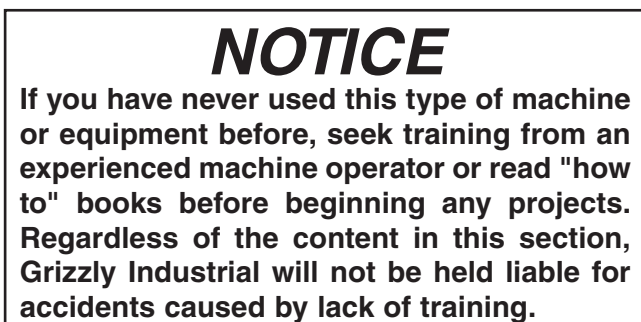
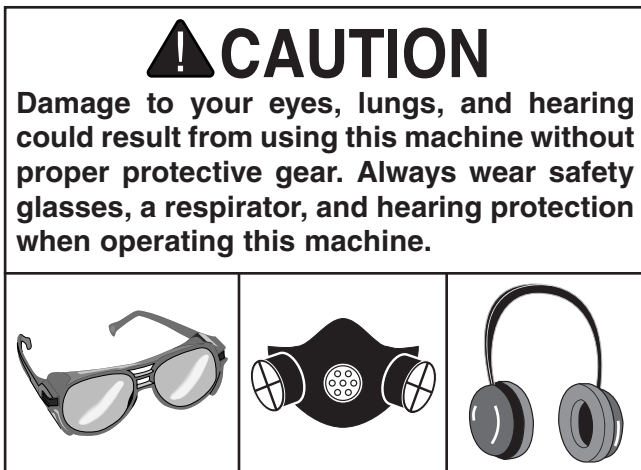
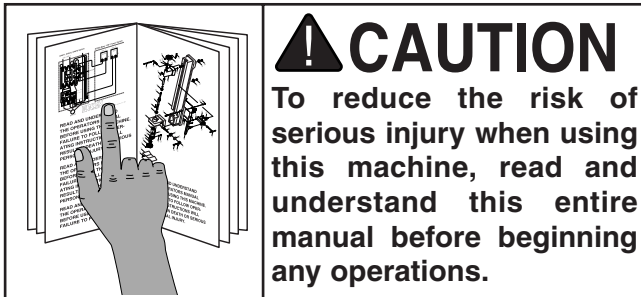

## Operation Overview

The purpose of this overview is to provide the novice machine operator with a basic understanding of how the machine is used during a typical operation, so the controls/components discussed later in this manual are easier to understand.

Due to the generic nature of this overview, it is not intended to be an instructional guide. To learn more about specific operations, read this entire manual, read "how to" books, and seek additional training from experienced machine operators.

To complete a typical operation, the operator does the following:

- Examines the workpiece to make sure it is suitable for cutting.
- Adjusts the blade tilt, if necessary, to the correct angle for the desired cut.
- For "Through Cuts," adjusts the blade height no more than  $\frac{1}{4}$ " higher than the thickness of the workpiece.
- Adjusts the fence to the desired width of cut, then locks it in place.
- Checks the outfeed side of the machine for proper support and to make sure the workpiece can safely pass all the way through the blade without interference.
- Puts on safety glasses and a respirator. Locates push sticks/blocks if needed.
- Starts the saw.
- Feeds the workpiece all the way through the blade while maintaining firm pressure on the workpiece against the table and fence, and keeping hands and fingers out of the blade path and away from the blade.
- Stops the machine immediately after the cut is complete.



# Basic Controls

**START/STOP Switch:** Starts and stops the motor. START button has a hole through it that can accommodate a padlock to disable the switch against unauthorized usage.

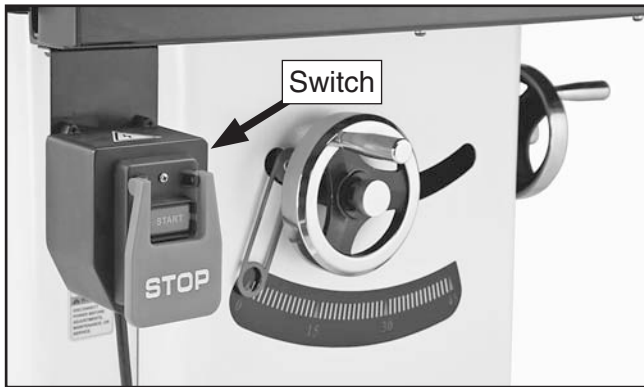

Figure 27. START/STOP switch.

**Blade Tilt:** To adjust the blade tilt, loosen the blade tilt lock, turn the blade tilt handwheel to position the blade at the desired angle, then tighten the lock shown in Figure 28.

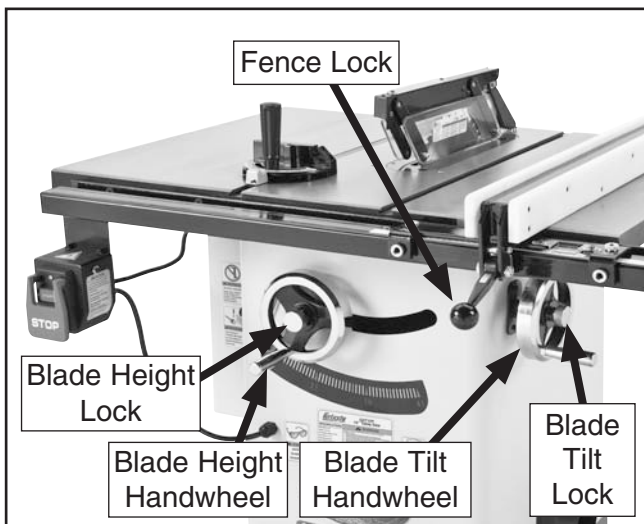

Figure 28. Basic table saw controls.

**Blade Height:** To set the blade height, unlock the blade height lock, turn the handwheel to set the blade height approximately 1/4" higher than the workpiece (for through cuts only), then re-tighten the blade height lock.

**Fence Lock:** After adjusting the fence to the desired width of cut, lock it in place by firmly pushing the fence lock down until it stops.

# Non-Through & Through Cuts

## Non-Through Cuts

A non-through cut is a sawing operation where the blade does not protrude above the top face of the wood stock, as shown in the Figure below.

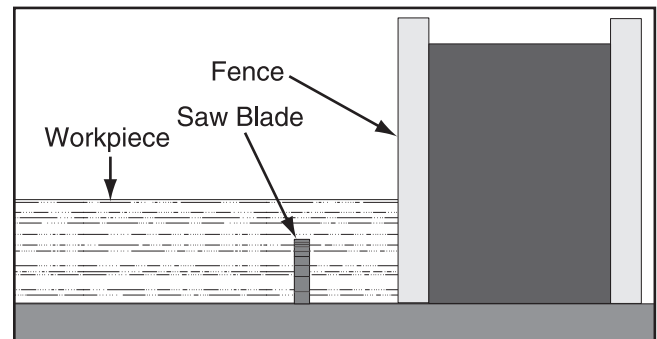

Figure 29. Example of a non-through cut.

Examples of non-through cuts include dadoes and rabbets. Non-through cuts have a higher risk of injury from kickback because the blade guard must be removed. However, the riving knife **MUST** be installed because it still provides some protection. When making non-through cuts with a dado blade, do not attempt to cut the full depth in one pass. Instead, take multiple light passes to reduce the load on the blade. A dado blade smaller than 10" will require removal of the riving knife, because the riving knife will be higher than the blade.

## Through Cuts

A through cut is a sawing operation in which the workpiece is completely sawn through, as shown in the Figure below. Examples of through cuts are rip cuts, cross cuts, miter cuts, and beveled cuts. The blade guard assembly **MUST** be used when performing through cuts.

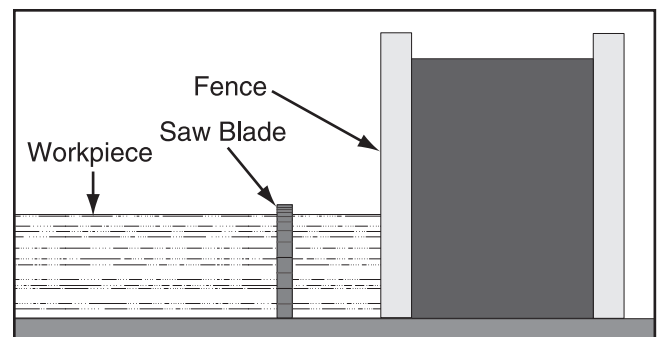

Figure 30. Example of a through cut (blade guard not shown for illustrative clarity).



# Workpiece Inspection

Some workpieces are not safe to cut on this machine or may need to be modified before they can be safely cut. **Before cutting, inspect all workpieces for the following:**

- **Material Type:** This machine is intended for cutting natural and man-made wood products, laminate covered wood products, and some plastics. Cutting drywall or cementitious backer board creates extremely fine dust and may reduce the life of the motor bearings. This machine is NOT designed to cut metal, glass, stone, tile, etc.; cutting these materials with a table saw greatly increases the risk of injury and damage to the saw or blade.
- **Foreign Objects:** Nails, staples, dirt, rocks and other foreign objects are often embedded in wood. While cutting, these objects can become dislodged and hit the operator, cause kickback, or break the blade, which might then fly apart. Always visually inspect your workpiece for these items. If they can't be removed, DO NOT cut the workpiece.
- **Large/Loose Knots:** Loose knots can become dislodged during the cutting operation. Large knots can cause kickback and machine damage. Choose workpieces that do not have large/loose knots or plan ahead to avoid cutting through them.
- **Wet or "Green" Stock:** Cutting wood with a moisture content over 20% causes unnecessary wear on the blades, increases the risk of kickback, and yields poor results.
- **Excessive Warping:** Workpieces with excessive cupping, bowing, or twisting are dangerous to cut because they are unstable and may move unpredictably when being cut.
- **Minor Warping:** Slightly cupped workpieces can be safely supported with cupped side facing the table or fence; however, workpieces supported on the bowed side will rock during the cut, which could cause kickback.

# Blade Requirements

The riving knife included with this machine is 0.1" (2.5mm) thick and is only designed for 10" diameter blades.

When choosing a main blade, make sure the blade size meets the requirements listed below. The thickness of the blade body and teeth can be measured with calipers or any precision measuring device.

## Blade Size Requirements:

- Body Thickness: 0.071"-0.094" (1.8-2.4mm)
- Kerf (Tooth) Thickness: 0.102"-0.126" (2.6-3.2mm)

# Blade Selection

This section on blade selection is by no means comprehensive. Always follow the saw blade manufacturer's recommendations to ensure safe and efficient operation of your table saw.

## Ripping Blade Features:

- Best for cutting with the grain
- 20-40 teeth
- Flat-top ground tooth profile
- Large gullets for large chip removal

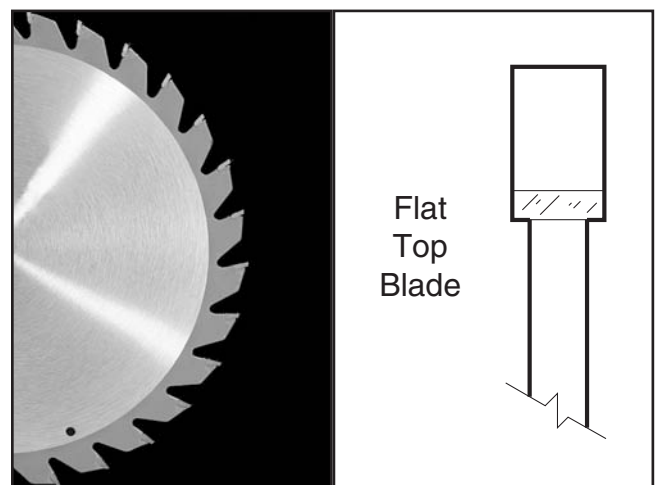

Figure 31. Ripping blade.



### Crosscut blade features:

- Best for cutting across the grain
- 60-80 teeth
- Alternate top bevel tooth profile
- Small hook angle and a shallow gullet

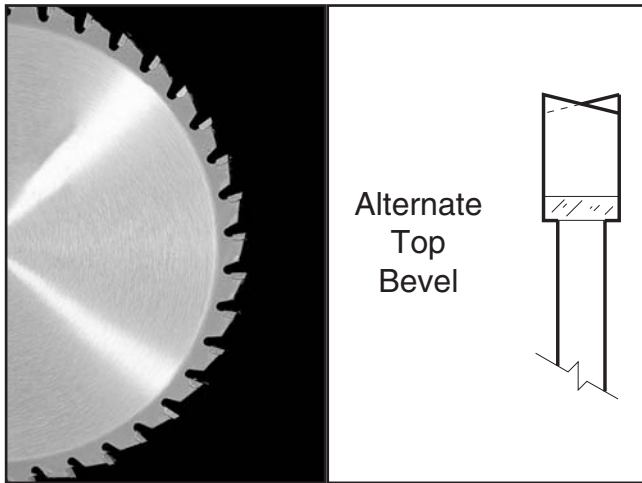

Figure 32. Crosscutting blade.

### Laminate blade features:

- Best for cutting plywood or veneer
- 40-80 teeth
- Triple chip tooth profile
- Very shallow gullet

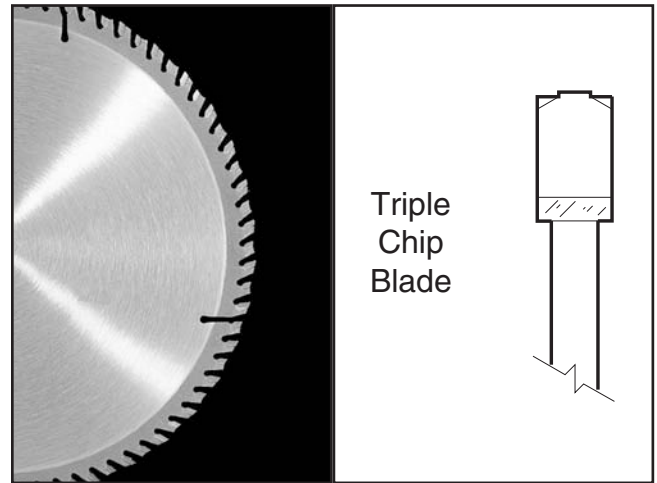

Figure 34. Laminate blade.

### Combination blade features:

- Designed to cut both with and across grain
- 40-50 teeth
- Alternate top bevel and flat, or alternate top bevel and raker tooth profile
- Teeth are arranged in groups
- Gullets are small and shallow (similar to a cross-cut blade), then large and deep (similar to a ripping blade)

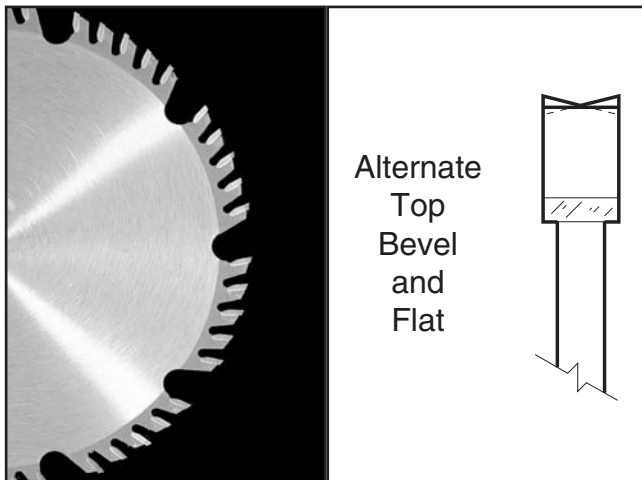

Figure 33. Combination blade.

**Thin Kerf Blade:** A blade with thinner kerf than a standard blade. Since the spreader/riving knife included with this table saw is sized for standard blades, thin kerf blades cannot be used on this saw unless they meet the **Blade Requirements** specified in this manual; otherwise, they will increase the risk of kickback.

### Dado Blades

**Stacked Dado Blade (see below):** Multiple blades are stacked together to control the cutting width. Stacked dado blades are more expensive than wobble blades, but typically produce higher quality results.

**Wobble Dado Blade:** A single blade mounted at a slight angle on an arbor hub. The blade angle is adjustable on the hub, and the width of the dado cut is controlled by the angle setting of the blade.

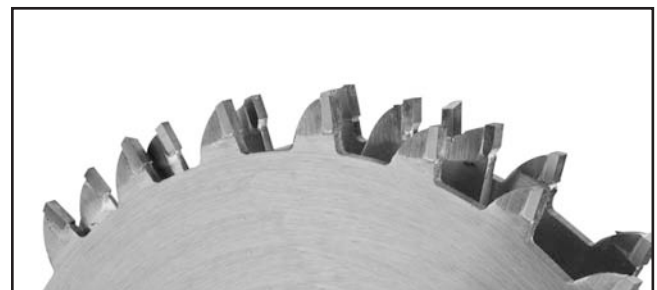

Figure 35. Stacked dado blade.





# Blade Installation

Review this section, even if your saw blade came pre-installed.

## To install the blade:

1. DISCONNECT SAW FROM POWER!
2. Remove the table insert and blade guard/riving knife, depending on what is installed.

**⚠ CAUTION**

Before proceeding with the next step, wear gloves to protect your hands while handling and installing the blade.

3. Push the arbor lock in and turn the blade until it locks in place, then use the arbor wrench to loosen and remove the arbor nut, flange, and blade.



**Figure 36.** Location of arbor lock.

**Note:** The arbor nut has right hand threads; turn it counterclockwise to loosen.

4. Slide the blade over the arbor with the teeth facing the front of the saw, as shown in **Figures 37**.

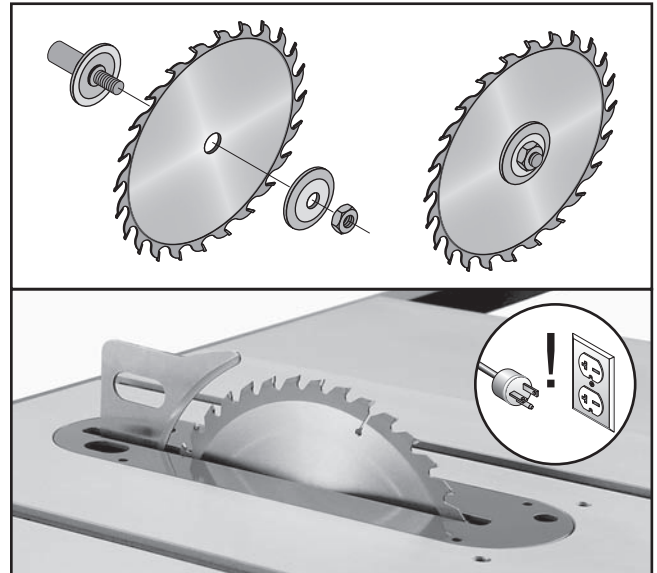

**Figure 37.** Blade order of installation and teeth facing the correct direction.

5. Re-install the arbor flange and the arbor nut.
6. Secure the blade with the arbor lock, then tighten the flange and arbor nut against the blade with the arbor wrench. **DO NOT** over-tighten.



# Blade Guard Assembly

The term "blade guard" refers to the assembly that consists of the clear polycarbonate shield, the spreader, and the anti-kickback pawls on each side of the spreader (see **Figure 38**). Each of these components have important safety functions during the operation of the saw.

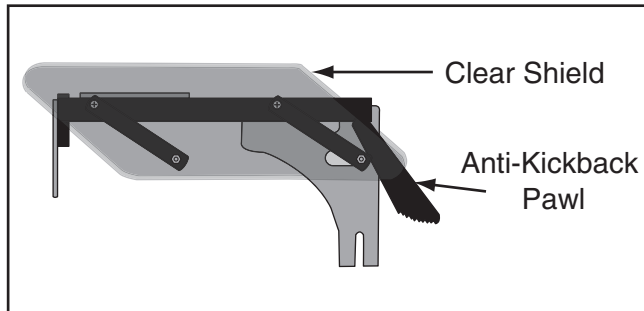

**Figure 38.** Blade guard assembly components.

## Guard

The clear polycarbonate guard allows the operator to see the blade cut the workpiece during operation. This guard is designed to lift as the workpiece is pushed into the blade and remain in contact with the workpiece throughout the entire cut.

The guard reduces injury risk by providing a barrier around the blade that prevents accidental contact and contains flying wood chips.

To ensure that the guard does its job effectively, the guard must always be in the downward position against the table during idle operation, and the hinge mechanism must be maintained in good working condition so the guard can freely pivot up and down to accommodate the height of the workpiece and return to the table surface.

## Spreader

The spreader is a metal plate that prevents the newly cut kerf of the workpiece from pinching the backside of the blade, causing kickback.

The spreader also acts as a barrier behind the blade to shield hands from being pulled into the blade if a kickback occurs.

## ! CAUTION

In order to work properly, the spreader cannot be bent or misaligned with the blade. If the spreader gets accidentally bent, take the time to straighten it or just replace it. Using a bent or misaligned spreader will increase the risk of kickback! Refer to Page 66 to check or adjust alignment if necessary.

## Installing Blade Guard & Spreader

1. DISCONNECT SAW FROM POWER!
2. Install the table insert.
3. Slide the knurled knob out (see **Figure 39**) and rotate it so it engages the upper bracket.

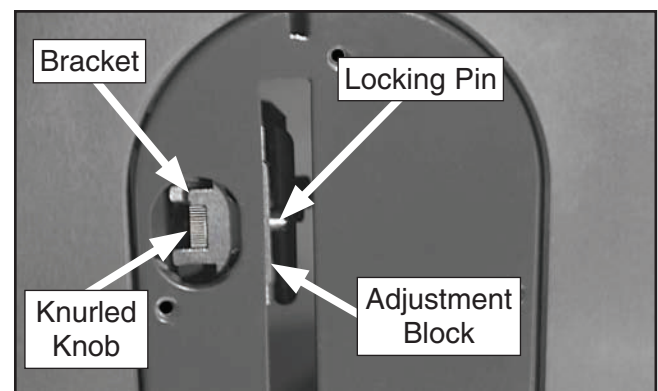
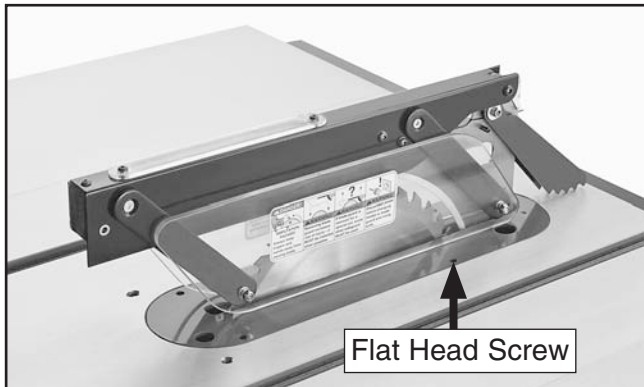

**Figure 39.** Knurled knob used to secure spreader.

4. Slide the blade guard spreader all the way down into the adjustment block, then rotate the knurled knob so it disengages the bracket and the locking pin engages the hole in the center of the spreader.
5. Give the spreader an upward tug to verify that it is locked.



The blade guard, when properly installed, should be setup similar to **Figure 40**. It should pivot freely up and down and return to the table in the resting position. It should also swing up high enough to accommodate the workpiece.



**Figure 40.** Blade guard installed.

6. Adjust the flat head screws to make sure the table insert is flush with the table (use a straightedge as a guide).
7. Swing one side of the blade guard up and out of the way.
8. While lifting up on the right spreader pawl, place a straightedge against the blade and the spreader, making sure the straightedge does not touch a blade tooth.

When properly aligned, the spreader/riving knife will be in the "Alignment Zone," shown in **Figure 41**, and will be parallel with the blade.

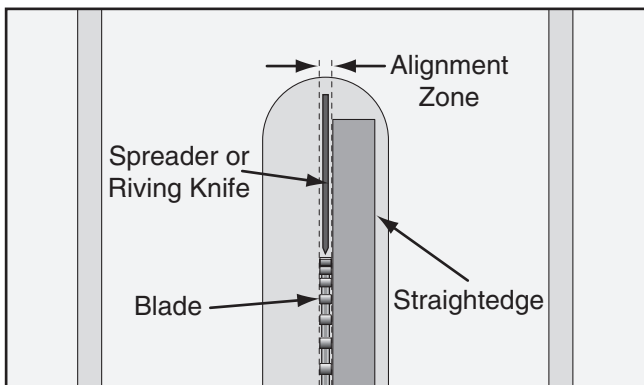

**Figure 41.** Spreader/riving knife alignment zone.

—If the spreader/riving knife is not inside the alignment zone and not parallel with the blade, then it needs to be adjusted. Proceed to "Adjusting Alignment" on **Page 66**.

## Anti-Kickback Pawls

The anti-kickback pawls allow the workpiece to travel in only one direction. If the workpiece moves backwards, such as during a kickback, the pawls will dig into the workpiece to slow or stop it.

To work properly, the pawls must return to their resting position after pivoting, as shown in **Figure 42**, and they must not be engaged in the arresting hooks.

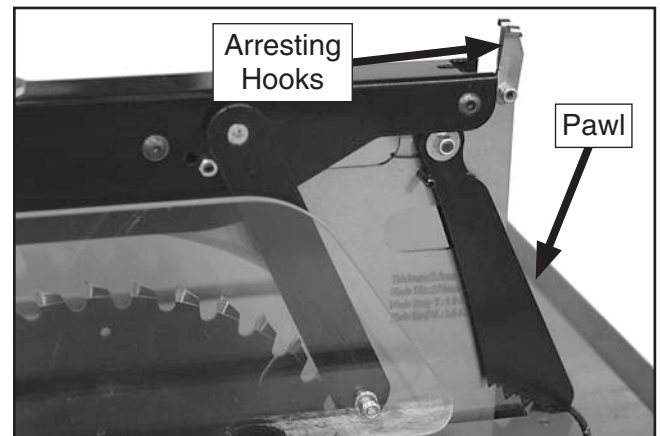

**Figure 42.** Pawls in resting position.

If the pawls fail to return to the resting position, the pivot area may need to be cleaned or the spring may have been dislodged or broken and will need to be fixed/replaced.



### **Disabling Pawls**

You might disable the pawls if you are concerned about them scratching a delicate workpiece, or if you believe that they will obstruct a narrow workpiece and cause feeding difficulty or loss of control. Use your best judgment before retracting the pawls, as they are provided for your safety.

## **⚠ CAUTION**

**We do not recommend disabling the pawls during normal operations unless absolutely necessary. In most situations, disabling the pawls will increase your risk of serious personal injury in the event of a kickback.**

## **⚠ CAUTION**

**The pawls are sharp and can lacerate fingers or hands. Use caution, and wear leather gloves when handling the pawls to reduce the risk of injury.**

### **To disable the pawls:**

1. DISCONNECT SAW FROM POWER!
2. Rotate one or both arresting hooks downward, then place the pawls on each of the hooks, as shown in **Figure 43**.

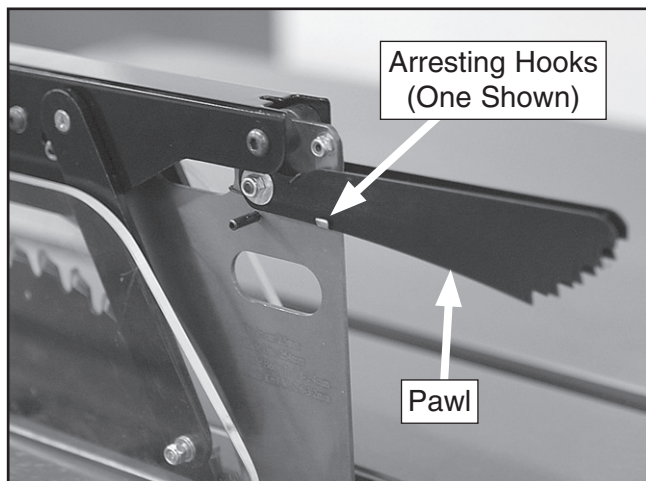

**Figure 43.** Pawl disabled.

### **Enabling Pawls**

To enable the pawls, lift up on each pawl and move them outward and down until they both touch the table surface, as shown in **Figure 42** on **Page 33**.

### **When to Use the Blade Guard**

The blade guard assembly **MUST** always be installed on the saw for all normal through cuts (those where the blade cuts all the way through the thickness of the workpiece). If the blade guard is removed for specific operations, always immediately replace it after those operations are complete.

### **When Not to Use the Blade Guard**

The blade guard cannot be used on any non-through cuts (those in which the blade does not cut all the way through the thickness of the workpiece).

**IMPORTANT:** Whenever the blade guard cannot be used, the riving knife must be installed.

Sometimes the blade guard or its components can get in the way when cutting very narrow workpieces or other specialized cuts. Because the blade guard is provided to decrease your risk of injury, it should not be used if it gets in the way of making a safe cut. Use good judgment!



# Riving Knife

The riving knife works in the same manner as the spreader on the blade guard assembly. It is a metal plate that prevents the newly cut workpiece from pinching the backside of the blade and causing kickback.

The key difference between the spreader and the riving knife is that the riving knife mounts below the blade's highest point of rotation, as shown in **Figure 44**.

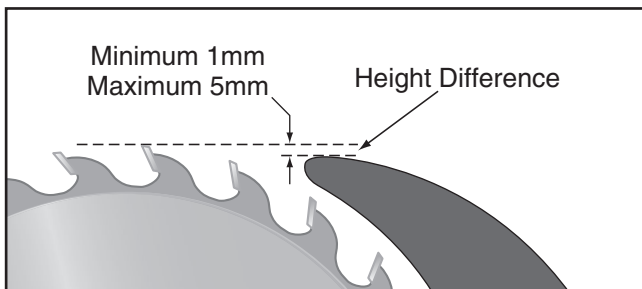
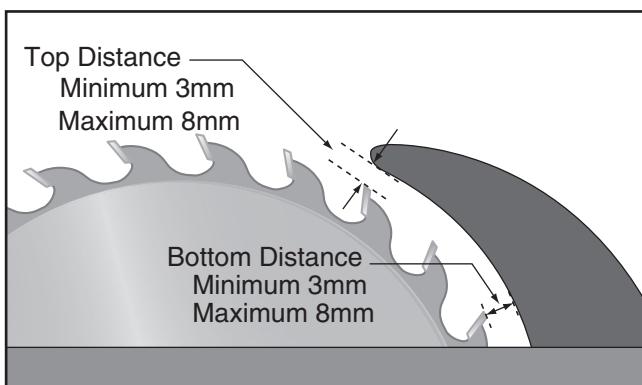

**Figure 44.** Height difference between riving knife and blade.

The height difference between the riving knife and the blade allows the workpiece to pass over the blade during non-through cuts (those in which the blade does not cut all the way through the thickness of the workpiece).

The riving knife acts as a barrier behind the blade to reduce the risk of hands being pulled into the blade if a kickback occurs.

The riving knife must be kept within the range shown in **Figure 45**. For that reason, we only recommend using a 10" blade for operations that require use of the riving knife.



**Figure 45.** Allowable top and bottom distances between riving knife and blade.

## CAUTION

To ensure that the riving knife works safely, it **MUST** be aligned with and correctly adjusted to the blade. Refer to Page 66 to check or adjust the riving knife alignment.

### How to Install the Riving Knife

The riving knife is installed in a similar manner to the blade guard and spreader. Refer to **Blade Guard** on Page 32 for installation instructions.

### When to Use the Riving Knife

Use the riving knife for all non-through cuts made with a standard table saw blade (i.e., dados or rabbet cuts, and when using a tenoning jig), or when using a 10" diameter dado blade.

Also, use the riving knife for those special operations where the blade guard or its components get in the way of safe operation, such as with very narrow cuts.

### When Not to Use the Riving Knife

Do not use the riving knife with a dado blade that has a diameter smaller than 10" in diameter. Otherwise, the riving knife height will exceed the blade height and the workpiece will hit the riving knife during the cut, forcing the operator into a dangerous situation of trying to turn the saw off with the workpiece stuck halfway through the cut.

In addition, although it is possible to use the riving knife for through cutting operations, the blade guard assembly offers far more injury protection and risk reduction than the riving knife. Therefore, **we strongly recommend** that you use the blade guard assembly instead of the riving knife for through cuts.



# Ripping

"Ripping" means cutting with the grain of a natural wood workpiece. In man-made materials such as MDF or plywood, ripping simply means cutting lengthwise.

## CAUTION

Serious injury can be caused by kickback. Kickback is a high-speed ejection of stock from the table saw toward an operator. The operator or bystanders may be struck by flying stock, or the operator's hands can be pulled into the blade during kickback.

### To make a rip cut:

1. Review **Preventing Kickback** on **Page 10** and take the necessary precautions to reduce the likelihood of kickback.
2. If using natural wood, joint one long edge of the workpiece on a jointer.
3. DISCONNECT SAW FROM POWER!
4. Ensure that the blade guard/spreader is installed.
5. Set the fence to the desired width of cut on the scale.
6. Adjust the blade height so the highest saw tooth protrudes no more than  $\frac{1}{4}$ " above the workpiece.
7. Set up safety devices such as featherboards or other anti-kickback devices.
8. Rotate the blade to make sure it does not come into contact with any of the safety devices.
9. Plug the saw into the power source, turn it **ON**, and allow it to reach full speed.

**Note:** The jointed edge of the workpiece must slide against the fence during the cutting operation.

10. Use a push stick to feed the workpiece through the saw blade, as shown in **Figure 46**, until the workpiece is completely beyond the saw blade.

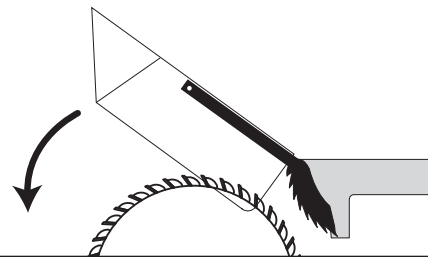

Figure 46. Typical ripping operation.

## CAUTION

Turn **OFF** the saw and allow the blade to come to a complete stop before removing the cut-off piece. Failure to follow this warning could result in serious personal injury.

## CAUTION



Keep the blade guard installed and in the down position. Failure to do this could result in serious personal injury or death.



# Crosscutting

"Crosscutting" means cutting across the grain of a natural wood workpiece. In other man-made materials, such as MDF or plywood, crosscutting means cutting across the width of the workpiece.

**To make a crosscut using the miter gauge:**

1. DISCONNECT SAW FROM POWER!
2. Ensure that the blade guard/spreader is installed.
3. Move the rip fence aside and position the miter gauge, adjusted to 90°, in a miter slot.
4. Adjust the blade height so the teeth protrude no more than ¼" above the workpiece.
5. Slide the miter gauge near the blade and adjust the workpiece so the blade will cut on the waste side of the line.
6. Plug in the table saw, turn it **ON**, and allow it to reach full speed.
7. Hold the workpiece firmly against the face of the miter gauge (as shown in **Figure 47**), and ease it through the blade until the workpiece is completely past the saw blade.

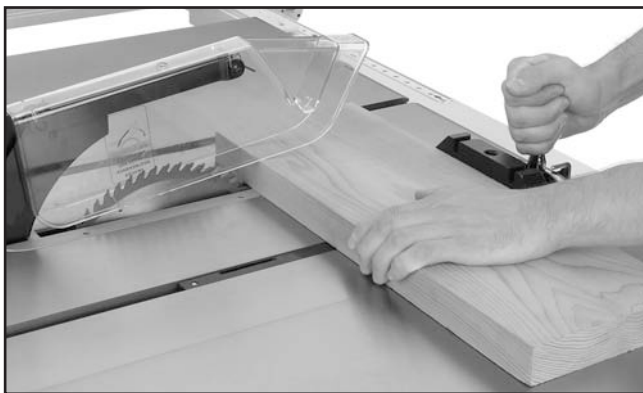

**Figure 47.** Typical crosscutting operation.

## **⚠ CAUTION**

Turn **OFF** the saw and allow the blade to come to a complete stop before removing the cut-off piece. Failure to follow this warning could result in serious personal injury

# Miter Cuts

A miter is an angled crosscut. Miters are usually cut in the same manner as crosscuts, using the miter gauge and a predetermined mark on the workpiece.

**To perform a miter cut:**

1. DISCONNECT SAW FROM POWER!
2. Ensure that the blade guard/spreader is installed.
3. Determine the angle of your cut. If the angle needs to be very precise, use a protractor to set the miter gauge to the blade.
4. Place the face of the miter gauge against the edge of the workpiece and place the bar across the face of the workpiece. Use the bar as a guide to mark your cut, as shown in **Figure 48**.



**Figure 48.** Example of marking miter line.

5. Place the miter gauge back into the slot and hold the workpiece firmly against the miter gauge body. Slide the miter gauge near the blade and adjust the workpiece so the blade will cut on the waste side of the line.
6. Proceed to make the cut in the same manner as described in the **Crosscutting** instructions.



# Blade Tilt/Bevel Cuts

When the blade tilt stop bolts are properly adjusted (as described on **Page 61**), the blade tilt handwheel allows the operator to tilt the blade to the left, between 0° and 45°. This is used most often when cutting bevels, compound miters, or chamfers. **Figure 49** shows an example of the blade when tilted to 45°.



**Figure 49.** Blade tilted to 45° for bevel cutting on a typical table saw.

# Dado Cutting

Commonly used in furniture joinery, a dado is a straight channel cut in the face of the workpiece. Dadoes are "non-through" cuts that can be made with a dado blade or a standard saw blade. The **Figure** below shows a cutaway view of a dado cut being made with a dado blade.

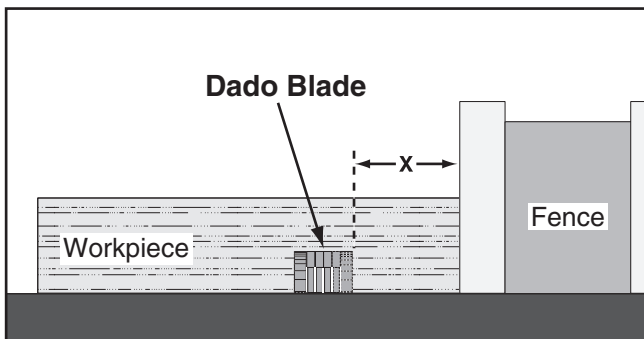

**Figure 50.** Example of a dado being cut with a dado blade.

## ⚠️ WARNING

**DO NOT** make through cuts with a dado blade. Dado blades are only intended for non-through cuts. Failure to heed this warning could result in serious injury.

## Installing a Dado Blade

1. DISCONNECT THE SAW FROM POWER!
2. Remove the table insert, the blade guard assembly or riving knife, and the saw blade.
3. Attach and adjust the dado blade system according to the dado blade manufacturer's instructions
4. Install the dado table insert.

## ⚠️ WARNING

Dado blades have a higher risk of kickback than normal blades because their larger size applies stronger forces to the workpiece. This risk increases relative to the depth and width of the cut. To minimize your risk of serious personal injury, ensure that stock is flat and straight, and make multiple light cuts (rather than one deep cut) to achieve the desired cutting depth.

## ⚠️ WARNING

**DO NOT** make through cuts with a dado blade. Dado blades are only intended for non-through cuts. Failure to heed this warning could result in serious injury.

## ⚠️ CAUTION

Never try to dado a warped board by holding it down against the table. If kickback occurs, your hand will likely be pulled into the blade, resulting in serious personal injury.





## Cutting Dados with a Dado Blade

Because dado blades are much wider than standard blades, they place a greater amount of force against the workpiece when cutting. This additional force increases the risk of kickback, requiring the operator to take additional steps when cutting to keep their injury risk at an acceptable level.

### **!WARNING**

**Dado blades have a higher risk of kickback than normal blades because their larger size applies stronger forces to the workpiece. This risk increases relative to the depth and width of the cut. To minimize your risk of serious personal injury, ensure that stock is flat and straight, and make multiple light cuts (rather than one deep cut) to achieve the desired cutting depth.**

The **Figure** below demonstrates the sequential process of making multiple, light cuts that get progressively deeper. The actual number of cuts used should be determined by workpiece hardness, total dado depth, and feed rate. In general, if you hear the motor slow down during the cut, you are cutting too deep or feeding too fast.

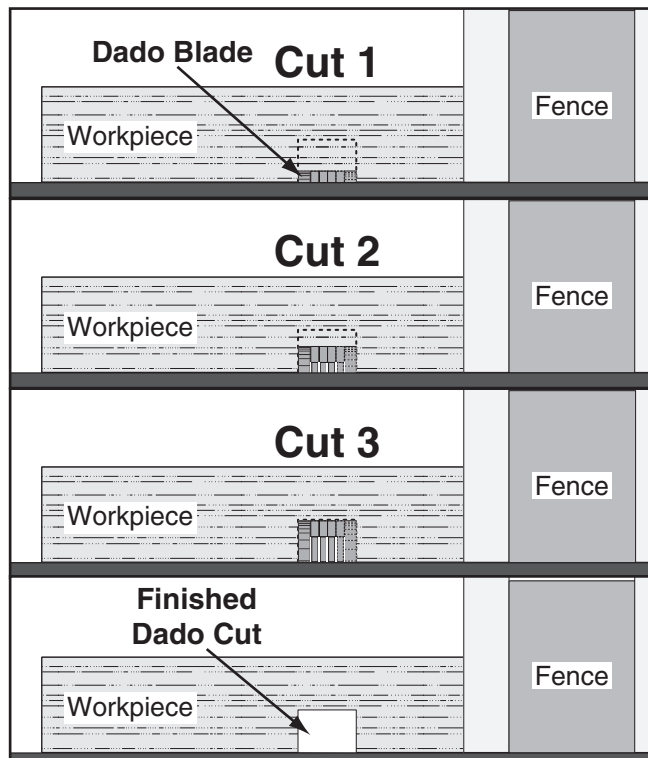

**Figure 51.** Example of dado being cut with multiple light cuts, instead of one deep cut.

### To cut a dado with a dado blade:

1. Adjust the dado blade to the desired depth of cut.
2. Adjust the distance between the fence and the inside edge of the blade, as shown in **Figure 50**, to dado the length of a workpiece.
  - If dadoing across the workpiece, use the miter gauge and carefully line up the desired cut with the dado blade. **DO NOT** use the fence in combination with the miter gauge.
3. Reconnect the saw to the power source.
4. Turn the saw **ON**. The blade should run smooth, with no vibrations.
5. When the blade has reached full speed, perform a test cut with a scrap piece of wood.
6. If the cut is satisfactory, repeat the cut with the actual workpiece.



## Cutting Dadoses with a Standard Blade

A ripping blade (described on **Page 29**) is typically the best blade to use for cutting dadoses when using a standard blade, because it removes sawdust very efficiently.

### To use a standard saw blade to cut dadoses:

1. DISCONNECT SAW FROM POWER!
2. Mark the width of the dado cut on the workpiece. Include marks on the edge of the workpiece so the cut path can be aligned when the workpiece is lying on the table.
3. Raise the blade up to the desired depth of cut (depth of dado channel desired).
4. Set the saw up for the type of cut you need to make, depending on if it is a rip cut (**Page 36**) or crosscut (**Page 37**).
5. Align the blade to cut one of the dado sides, as shown in **Figure 52**.

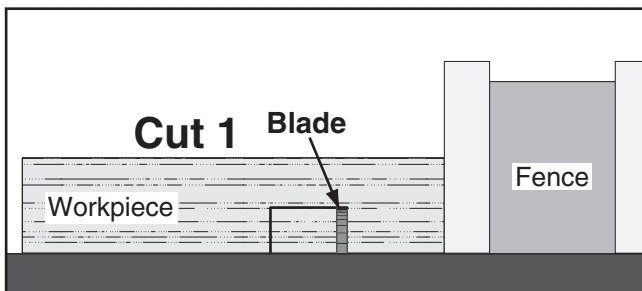

**Figure 52.** First cut for a single-blade dado.

6. Reconnect the saw to the power source and turn the saw **ON**. Allow the blade to reach full speed, then perform the cutting operation.
7. Repeat the cutting operation on the other side of the dado channel, as shown in **Figure 53**.

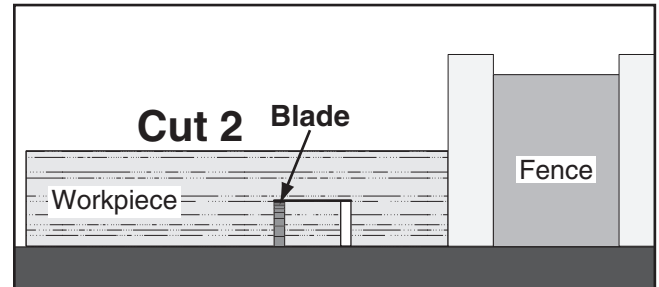

**Figure 53.** Second cut for a single blade dado.

8. Make additional cuts (see **Figure 54**) in the center of the dado to clear out the necessary material. The dado is complete when the channel is completely cleared out.



**Figure 54.** Additional single blade dado cuts.



# Rabbet Cutting

Commonly used in furniture joinery, a rabbet is an L-shaped groove cut in the edge of the workpiece. Rabbets can be cut with either a dado blade or a standard saw blade.

Rabbet cutting on the edge of the workpiece with a dado blade requires a sacrificial fence (**Figure 55**). Make the sacrificial fence the same length as the fence and  $\frac{3}{4}$ " thick. Attach it to the fence with screws or clamps, making sure they are all secure and tight. Raise the blade into the sacrificial fence to the height needed.

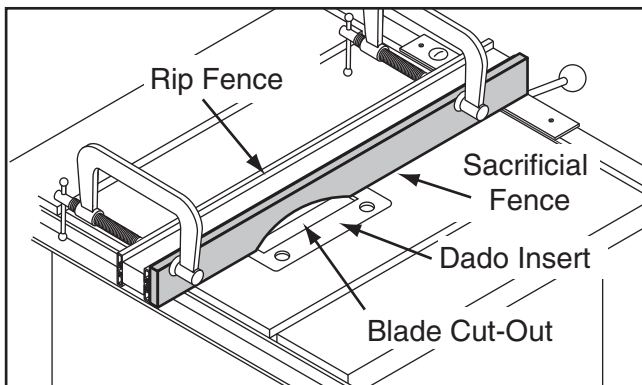

**Figure 55.** Sacrificial fence.

## **! WARNING**

Dado blades have a higher risk of kickback than normal blades because their larger size applies stronger forces to the workpiece. This risk increases relative to the depth and width of the cut. To minimize your risk of serious personal injury, ensure that stock is flat and straight, and make multiple light cuts (rather than one deep cut) to achieve the desired cutting depth.

## **! CAUTION**

Always use push sticks, featherboards, push paddles and other safety accessories whenever possible to increase safety and control during operations which require that the blade guard be removed from the saw. ALWAYS replace the blade guard after dadoing is complete.

## Cutting Rabbets with a Dado Blade

1. DISCONNECT SAW FROM POWER!
2. Adjust the dado blade to the height needed for the rabbeting operation. When cutting deep rabbets, take more than one pass to reduce the risk of kickback.
3. Adjust the fence and align the workpiece to perform the cutting operation, as shown in **Figure 56**.

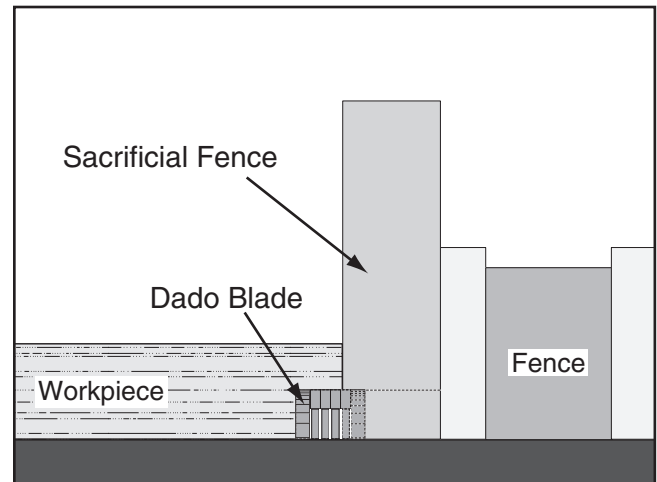

**Figure 56.** Rabbet cutting.

4. Reconnect the saw to the power source and turn the saw **ON**. When the blade has reached full speed, perform a test cut with a scrap piece of wood.  
—If the cut is satisfactory, repeat the cut with the final workpiece.



## Cutting Rabbets with a Standard Blade

A ripping blade is typically the best blade to use for cutting rabbets when using a standard blade because it removes sawdust very efficiently. (See **Page 29** for blade details.) Also, a sacrificial fence is not required when cutting rabbets with a standard blade.

### To cut rabbets with the standard blade:

1. DISCONNECT SAW FROM POWER!
2. Ensure that the riving knife and standard table insert are installed.
3. Mark the width of the rabbet cut on the edge of the workpiece, so you can clearly identify the intended cut while it is laying flat on the saw table.
4. Raise the blade up to the desired depth of cut (depth of rabbet channel desired).
5. Stand the workpiece on edge, as shown in **Figure 57**, then adjust the fence so the blade is aligned with the inside of your rabbet channel.

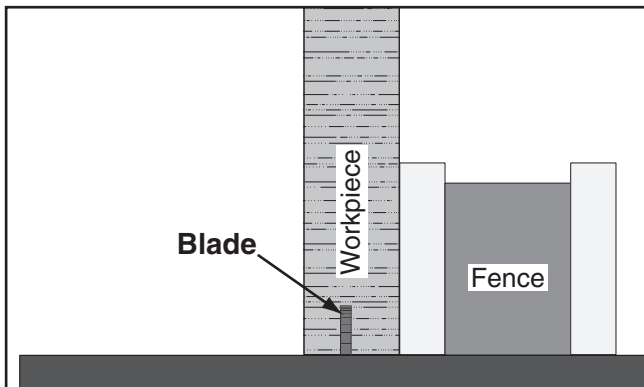

**Figure 57.** Rabbet cutting with a standard blade.

—If the workpiece is very tall, or is unstable when placed against the fence, lay it flat on the table and use a dado blade to perform the rabbet cut.

**! CAUTION**

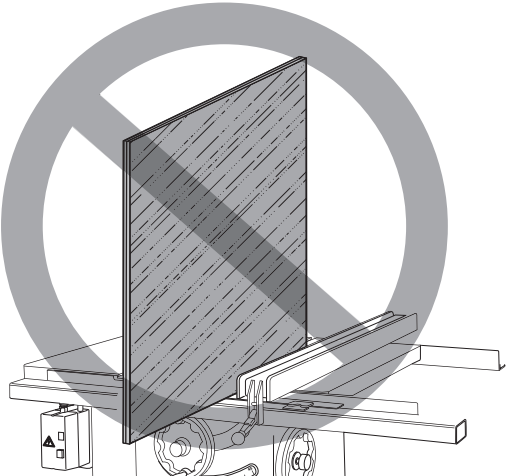

**DO NOT** place a tall board on edge to perform a rabbet cut with a standard blade. Workpieces that are too tall to properly support with the fence can easily shift during operation and cause kickback. Instead, place the stock flat on the saw and perform the rabbet cut with a dado blade, as instructed on **Page 41**.

6. Reconnect the saw to the power source, then perform the cut.
7. Lay the workpiece flat on the table, as shown in **Figure 58**, adjust the saw blade height to intersect with the first cut, then perform the second cut to complete the rabbet.

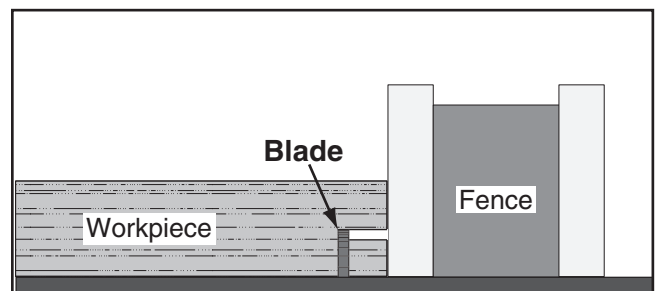

**Figure 58.** Second cut to create a rabbet.



# Resawing

## ⚠ CAUTION

Resawing operations require proper procedures to avoid serious injury. Extra care must be taken to prevent kickback when resawing. Any tilting or movement of the workpiece away from the fence will cause kickback. Be certain that stock is flat and straight. Failure to follow these warnings could result in serious personal injury.

Resawing is the process of cutting a thick piece of stock into one or more thinner pieces. Although resawing can be done with a table saw, we strongly recommend that you use a bandsaw instead.

A bandsaw is the ideal machine for resawing, and resawing with one is fairly easy and safe. A table saw is not intended for resawing, and resawing with one is difficult and dangerous due to the increased risk of kickback from binding and deep cuts, and the increased risk of injury from having to remove the guard.

If you insist on resawing with a table saw, DO NOT do so without using a resaw barrier and wearing a full face shield. The following instructions describe how to build a resaw barrier and add an auxiliary fence to your standard fence, to reduce the risk injury from resawing on a table saw.

**Note:** To determine the maximum resawing height for this table saw, find the maximum blade height, then double it and subtract  $\frac{1}{8}$ ".

## Making Resaw Barrier

The resaw barrier acts in tandem with the rip fence when resawing to provide tall support for the workpiece to minimize the probability of it binding against the blade and causing kickback.

Tools Needed:	Qty
Table Saw .....	1
Jointer and Planer .....	Recommended
Clamps .....	2 Minimum
Drill and Drill Bits .....	1

### Components Needed for Resaw Barrier:

Wood* $\frac{3}{4}$ " x $5\frac{1}{2}$ " x Length of Fence .....	1
Wood* $\frac{3}{4}$ " x 3" x Length of Fence .....	1
Wood Screws #8 x 2" .....	4
Wood Glue .....	As Needed

\* Only use furniture-grade plywood, kiln dried hardwood, or HDPE plastic to prevent warping.

### To build the resaw barrier:

1. Cut your wood pieces to the size specified above. If you are using hardwood, cut the pieces oversize, then joint and plane them to the correct size to make sure they are square and flat.
2. Pre-drill and countersink four holes approximately  $\frac{3}{8}$ " from the bottom of the  $5\frac{1}{2}$ " tall wood piece.
3. Glue the end of the 3" board, then clamp the boards at a  $90^\circ$  angle with the larger board in the vertical position, as shown in **Figure 59**, fasten together with the wood screws.

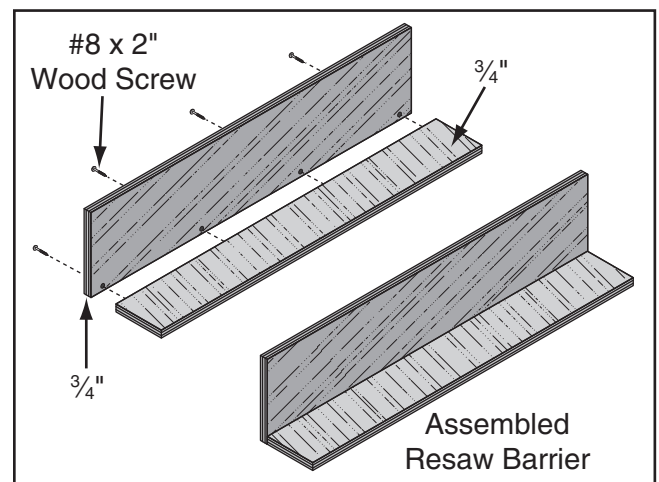

**Figure 59.** Resaw barrier.



## Auxiliary Fence

The auxiliary fence is necessary if you are resawing a workpiece that is taller than it is wide. It should be no less than 1/2" shorter than the board to be resawn.

### Components Needed for the Auxiliary Fence:

Wood\* 3/4" x (Height) x Length of Fence ..... 1

\* Only use furniture-grade plywood, kiln dried hardwood, or HDPE plastic to prevent warping.

### Tools Needed for the Auxiliary Fence:

Table Saw ..... 1  
 Jointer and Planer ..... Recommended  
 Clamps ..... 2 Minimum

### To build the auxiliary fence:

1. Cut the auxiliary fence board to size. If you are using hardwood, cut the board oversize, then joint and plane the board to the correct size to make sure the board is square and flat.
2. Unthread the fence face mounting hardware and remove the fence face from the fence assembly.
3. Place the auxiliary fence next to the fence face you removed in **Step 1**, mark the location of the nine mounting holes on the auxiliary fence, then drill the holes.
4. Use the mounting hardware that had previously attached the fence face to attach the auxiliary fence. The end result should be similar to **Figure 60**.

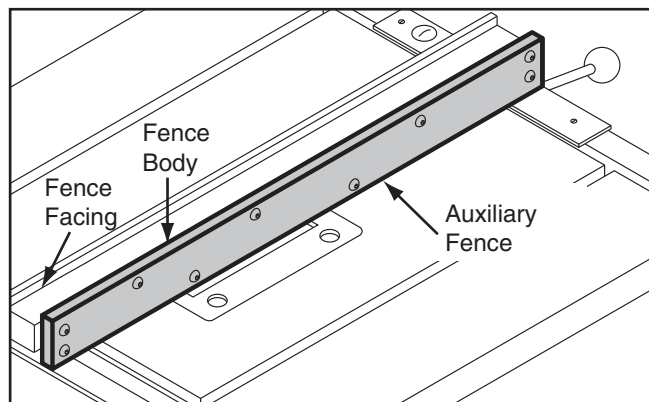

**Figure 60.** Auxiliary fence.

## Resawing Operations

The table saw motor is pushed to its limits when resawing. If the motor starts to bog down, slow down your feed rate. Motor overloading and blade wear can be reduced by using a ripping blade. Ripping blades are designed to clear the sawdust quickly.

### Components Needed for Resawing:

Zero-clearance Insert ..... 1  
 Ripping Blade 10" ..... 1  
 Clamps ..... 2  
 Shop Made Auxiliary Fence ..... 1  
 Shop Made Resaw Barrier ..... 1

## CAUTION

**You may experience kickback during this procedure. Stand to the side of the blade and wear a full face shield to prevent injury when resawing.**

### To perform resawing operations:

1. DISCONNECT SAW FROM POWER!
2. Remove the standard table insert and the blade guard assembly.
3. Install a ripping blade, install the riving knife, lower the blade below the table, then install the optional Model T23146 zero clearance table insert.
4. Attach the auxiliary fence and set it to the desired width.

**Note:** When figuring out the correct width, don't forget to account for blade kerf and the inaccuracy of the fence scale while the auxiliary fence is installed.

5. Place the workpiece against the auxiliary fence and slide the resaw barrier against the workpiece, as shown in **Figure 61**. Now clamp the resaw barrier to the top of the table saw at both ends.



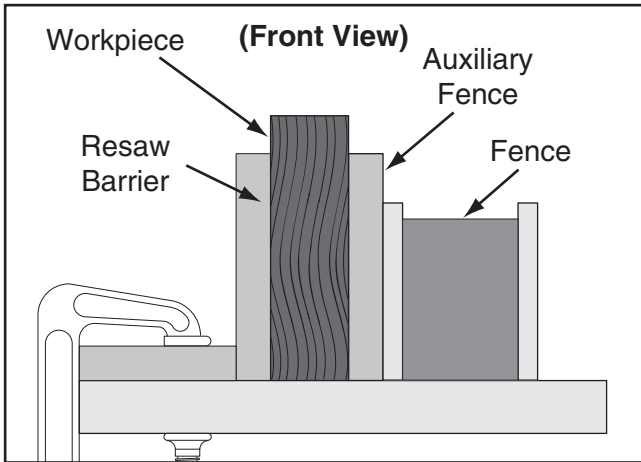

**Figure 61.** Ideal resaw workpiece setup.

6. Lower the blade completely below the table, and slide the workpiece over the blade to make sure it moves smoothly and fits between the resaw barrier and fence.
7. Raise the blade approximately an inch, or close to half the height of the workpiece (**Figure 62**), whichever is less.

## **CAUTION**

The danger of kickback increases relative to the depth of a cut. Reduce the risk of kickback by making multiple passes to achieve the desired depth of cut. Failure to follow these warnings could result in serious personal injury.

## **CAUTION**

Always use push sticks or push paddles to increase safety and control during operations which require that the blade guard and spreader must be removed from the saw. **ALWAYS** replace the blade guard after resawing is complete.

8. Plug in the table saw, turn it **ON**, and use a push stick or push block to feed the workpiece through the blade, using a slow and steady feed rate.
9. Flip the workpiece end for end, keeping the same side against the fence, and run the workpiece through the blade.

10. Repeat **Steps 7–9** until the blade is close to half of the height of the board to be resawn. The ideal completed resaw cut will leave an  $\frac{1}{8}$ " connection when the resawing is complete as shown in **Figure 62**. Leaving an  $\frac{1}{8}$ " connection will reduce the risk of kickback.

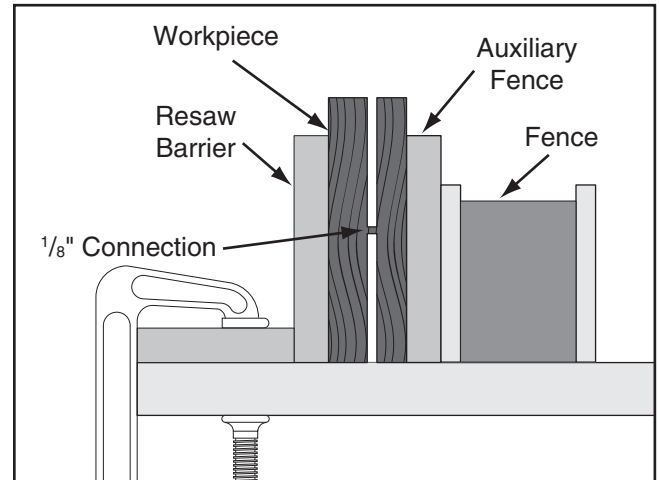

**Figure 62.** Ideal completed resaw cut.

11. Turn **OFF** the table saw, then separate the parts of the workpiece and hand plane the remaining ridge to remove it.
12. When finished resawing, remove the resaw barrier and auxiliary fence, then re-install the blade guard/spreader or riving knife and standard table insert.



# SECTION 5: SHOP MADE SAFETY ACCESSORIES

## Featherboards

Easily made from scrap stock, featherboards provide an added degree of protection against kickback, especially when used together with push sticks. They also maintain pressure on the workpiece to keep it against the fence or table while cutting, which makes the operation easier and safer because the cut can be completed without the operator's hands getting near the blade. The angled ends and flexibility of the fingers allow the workpiece to move in only one direction.

### Making a Featherboard

This sub-section covers the two basic types of featherboards: 1) Those secured by clamps, or 2) those secured with the miter slot.

#### Material Needed for Featherboard

Hardwood  $\frac{3}{4}$ " x 3" x 10" (Minimum)  
 Hardwood  $\frac{3}{4}$ " x 6" x 28" (Maximum) ..... 1

#### Additional Material Needed for Mounting Featherboard in Miter Slot

Hardwood  $\frac{3}{8}$ " x (Miter Slot Width) x 5"L ..... 1  
 Wing Nut  $\frac{1}{4}$ "-20..... 1  
 Flat Head Screw  $\frac{1}{4}$ "-20 x 2" ..... 1  
 Flat Washer  $\frac{1}{4}$ "-20..... 1

#### To make a featherboard:

1. Cut a hardwood board approximately  $\frac{3}{4}$ " thick to size. The length and width of the board can vary according to your design. Most featherboards are 10"–28" long and 3"–6" wide. Make sure the wood grain runs parallel with the length of the featherboard, so the fingers you will create in **Step 3** will bend without breaking.
2. Cut a 30° angle at one end of the board.

## ⚠ CAUTION

We recommend using a bandsaw for making fingers in the next step because it tends to be safer. A table saw can be used, but it will over-cut the underside of the ends, produce a thicker kerf, and require you to stop the blade half-way through the cut, which can be dangerous.

3. Make a series of end cuts with the grain  $\frac{3}{8}$ "– $\frac{1}{4}$ " apart and 2"–3" long, as shown in **Figure 63 (A)**. Alternatively, start cuts at 2"-3" deep, then make them progressively deeper, as shown in **Figure 63 (B)**.

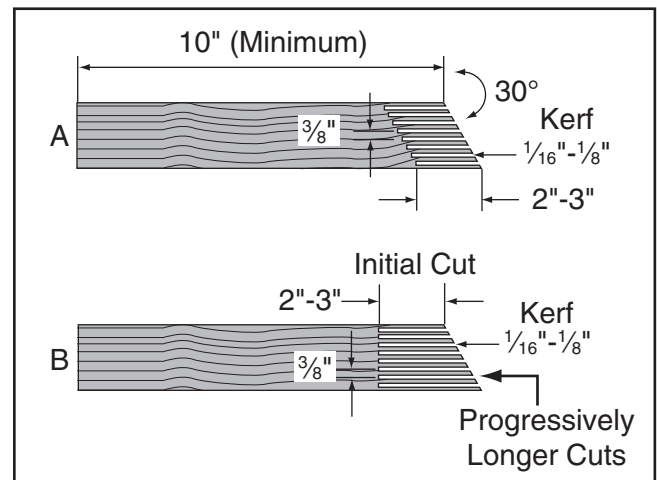

**Figure 63.** Patterns for featherboards (top view shown).

**IMPORTANT:** Cuts made across the grain result in weak fingers that easily break when flexed. When made correctly, the fingers should withstand flexing from moderate pressure. To test the finger flexibility, push firmly on the ends with your thumb. If the fingers do not flex, they are likely too thick (the cuts are too far apart).

## NOTICE

Only Steps 1–3 are required to make a clamp-mounted featherboard. Refer to Page 48 for instructions on clamping.





4. Rout a  $\frac{1}{4}$ "- $\frac{3}{8}$ " wide slot 4"-5" long in the workpiece and 1"-2" from the short end of the featherboard (see **Figure 64**).

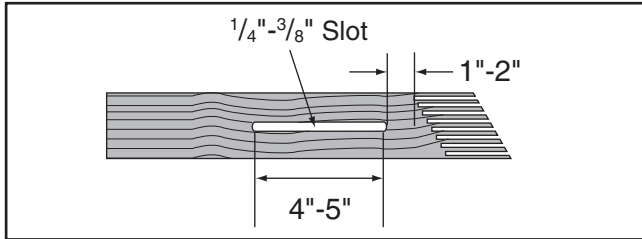

**Figure 64.** Slot routed in featherboard.

5. Cut a miter bar that will fit in the table miter slot approximately 5" long, as shown in **Figure 65**.

**Tip:** Consider making the miter bar longer for larger featherboards—approximately half the length of the total featherboard—to support the force applied to the featherboard during use.

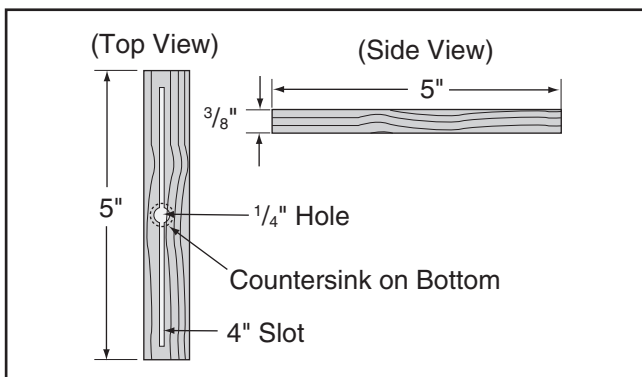

**Figure 65.** Miter bar pattern.

6. Drill a  $\frac{1}{4}$ " hole in the center of the bar, then countersink the bottom to fit a  $\frac{1}{4}$ "-20 flat head screw.

7. Mark a 4" line through the center of the countersunk hole in the center, then use a jig saw with a narrow blade to cut it out.
8. Assemble the miter bar and featherboard with a  $\frac{1}{4}$ "-20 x flat head screw, flat washer, and a wing nut or a star knob (see **Figure 66**). Congratulations! Your featherboard is complete.

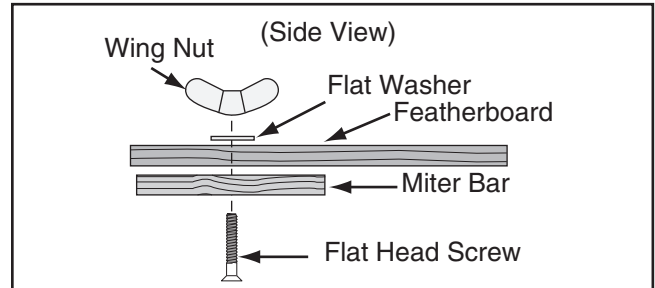

**Figure 66.** Assembling miter slot featherboard components.

**Note:** The routed slot, countersink hole, and the flat head screw are essential for the miter bar to clamp into the miter slot. When the wing nut is tightened, it will draw the flat head screw upward into the countersunk hole. This will spread the sides of the miter bar and force them into the walls of the miter slot, locking the featherboard in place.

**Tip:** The length of the flat head screw depends on the thickness of the featherboard—though  $1\frac{1}{2}$ " to 2" lengths usually work.

Now, proceed to **Mounting Featherboard in Miter Slot** on **Page 48**.



## Mounting Featherboards w/Clamps

1. Lower the saw blade, then adjust the fence to the desired width and secure it.
2. Place the workpiece against the fence, making sure it is 1" in front of the blade.
3. Place a featherboard on the table away from the blade so all fingers point forward and contact the workpiece (see **Figure 67**).

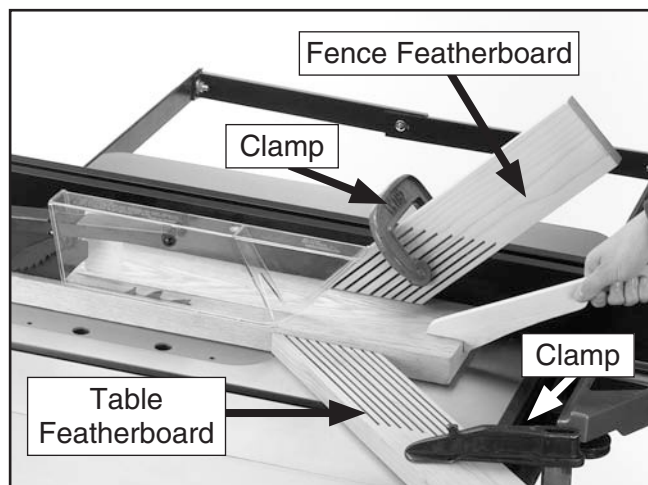
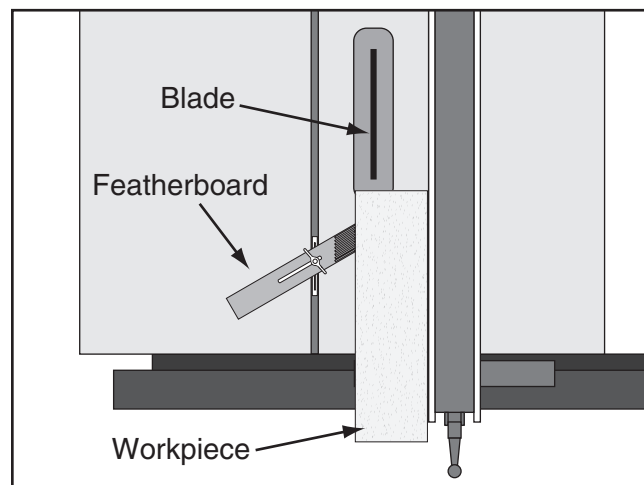

**Figure 67.** Example of featherboards secured with clamps.

4. Secure the featherboard to the table with a clamp.
5. Check the featherboard by pushing it with your thumb to ensure it is secure.  
—If the featherboard moves, tighten the clamp more.
6. Mount a second featherboard to the fence with another clamp (see **Figure 67**), then repeat **Step 5** to ensure it is secure.

## Mounting Featherboard in Miter Slot

1. Lower the saw blade, then adjust the fence to the desired width and secure it.
2. Place the workpiece evenly against the fence, making sure it is 1" in front of the blade.
3. Slide the featherboard miter bar into the miter slot, making sure the fingers slant toward the blade, as shown in **Figure 68**.



**Figure 68.** Featherboard installed in miter slot and supporting workpiece for ripping cut.

4. Position the fingered edge of the featherboard against the edge of the workpiece, so that all of the fingers contact the workpiece. Slide the featherboard toward the blade until the first finger is nearly even with the end of the workpiece, which should be 1" away from the blade.
5. Double check the workpiece and the featherboard to ensure they are properly positioned as described in **Step 4**. Then secure the featherboard to the table. Check the featherboard by hand to make sure it is tight.

**Note:** *The featherboard should be placed firmly enough against the workpiece to keep it against the fence but not so tight that it is difficult to feed the workpiece.*



# Push Sticks

When used correctly, push sticks reduce the risk of injury by keeping hands away from the blade while cutting. In the event of an accident, a push stick can also absorb damage that would have otherwise happened to hands or fingers.

## Using a Push Stick

Use push sticks whenever your hands will get within 12" of the blade. To maintain control when cutting large workpieces, start the cut by feeding with your hands then use push sticks to finish the cut, so your hands are not on the end of the workpiece as it passes through the blade.

**Feeding:** Place the notched end of the push stick against the end of the workpiece (see inset **Figure** below), and move the workpiece into the blade with steady downward and forward pressure.

**Supporting:** A second push stick can be used to keep the workpiece firmly against the fence while cutting. When using a push stick in this manner, only apply pressure before the blade; otherwise, pushing the workpiece against or behind the blade will increase the risk of kickback (see "Push Stick Prohibition Zone" in the **Figure** below).

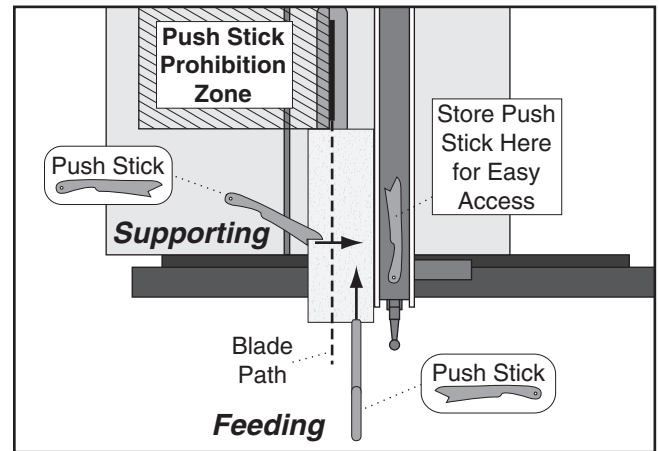

**Figure 69.** Using push sticks to rip narrow stock.

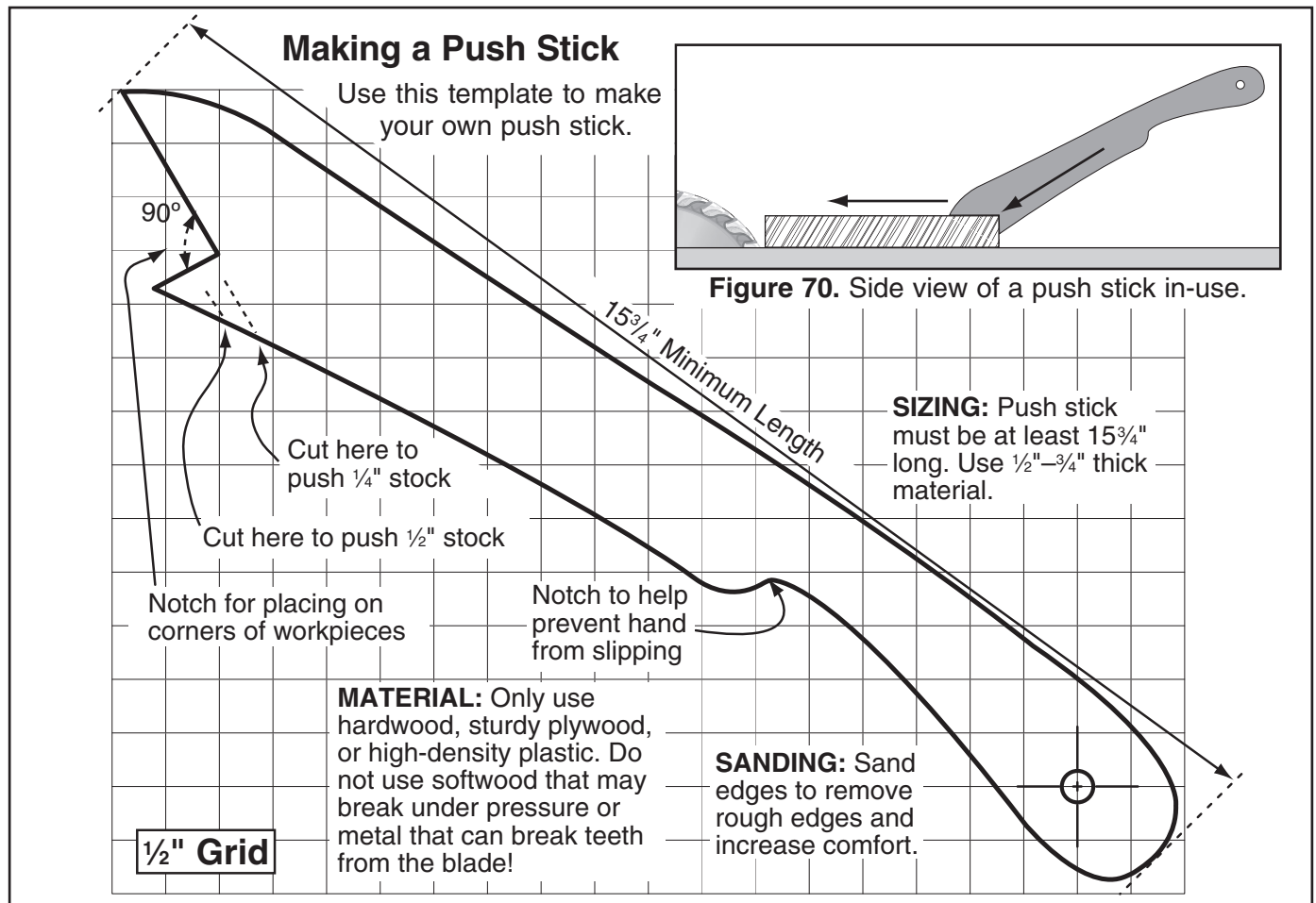

**Figure 71.** Template for a basic shop-made push stick (not shown at actual size).



# Push Blocks

When used correctly, a push block reduces the risk of injury by keeping hands away from the blade while cutting. In the event of an accident, a push block often takes the damage that would have otherwise happened to hands or fingers.

## Using a Push Block

A push block can be used in place of or in addition to a push stick for feeding workpieces into the blade. Due to their design, push blocks allow the operator to apply firm downward pressure on the workpiece that could not otherwise be achieved with a push stick.

The push block design on this page can be used in two different ways (see inset **Figure** below). Typically, the bottom of the push block is used until the end of the workpiece reaches the blade.

The notched end of the push block is then used to push the workpiece the rest of the way through the cut, keeping the operator's hands at a safe distance from the blade. A push stick is often used at the same time in the other hand to support the workpiece during the cut (see "Using a Push Stick" on previous page).

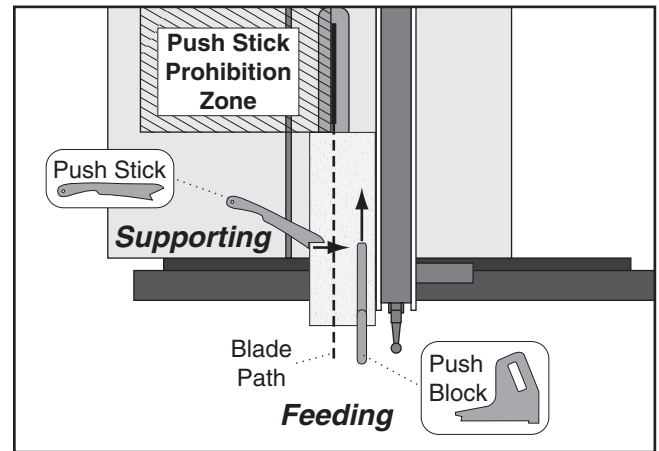

**Figure 73.** Using a push block and push stick to make a rip cut.

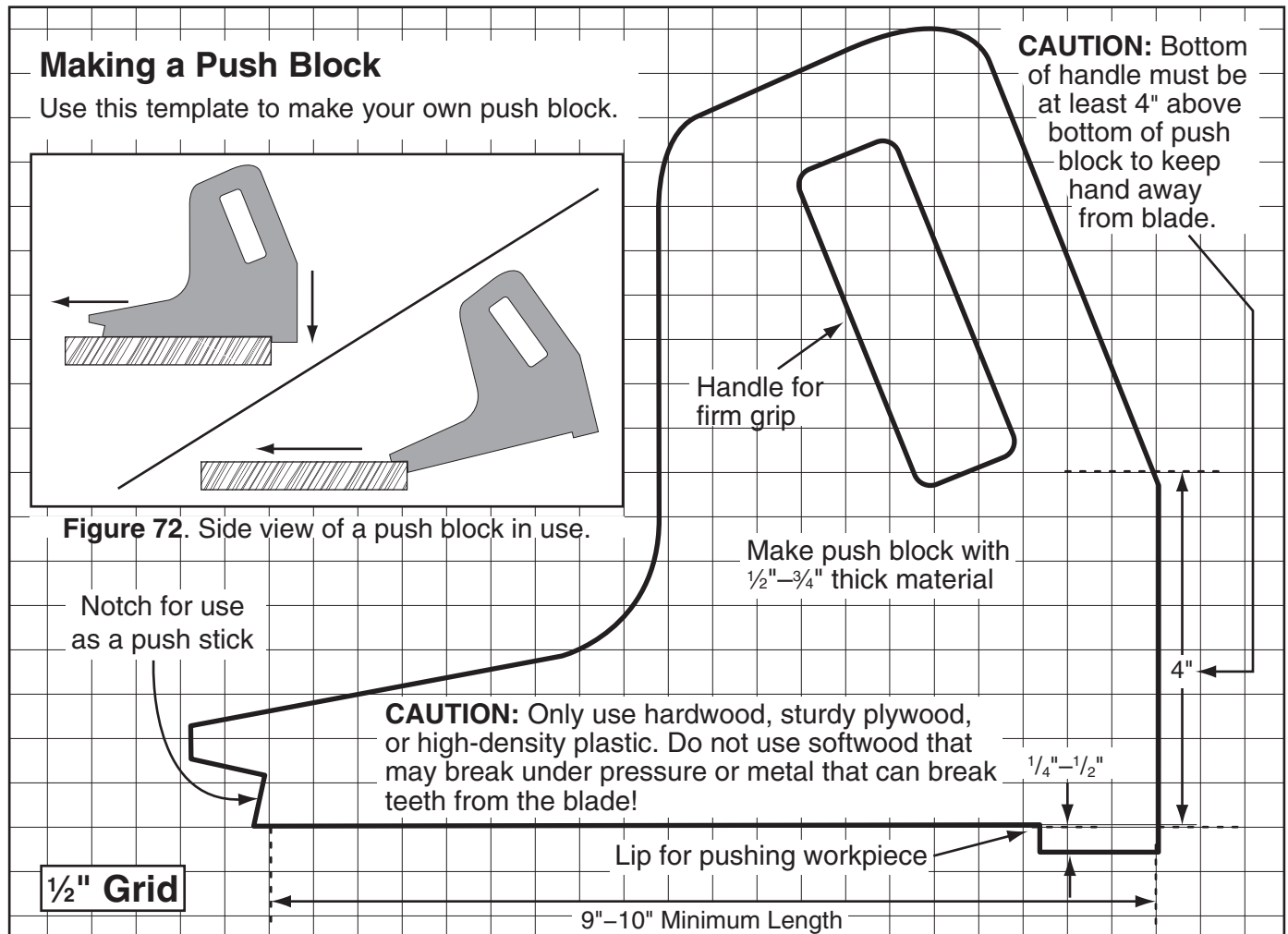

**Figure 74.** Template for a shop-made push block (shown at 50% of full size).



# Narrow-Rip Auxiliary Fence & Push Block

There are designs for hundreds of specialty jigs that can be found in books, trade magazines, and on the internet. These types of jigs can greatly improve the safety and consistency of cuts. They are particularly useful during production runs when dozens or hundreds of the same type of cut need to be made.

The narrow-rip auxiliary fence and push block system shown in this section is an example of a specialty jig that can be made to increase the safety of very narrow rip cuts.

## Material Needed for Narrow Rip Auxiliary Fence & Push Block

Hardwood  $\frac{3}{4}$ " x 3" x Length of Fence ..... 1  
 Plywood  $\frac{3}{4}$ " x  $5\frac{1}{4}$ " x Length of Fence ..... 1  
 Wood Screws #8 x  $1\frac{1}{2}$ " ..... 8

## Material Needed for Push Block

Hardwood or Plywood  $\frac{3}{4}$ " x 15" x  $5\frac{5}{8}$ " ..... 1  
 Hardwood or Plywood  $\frac{3}{4}$ " x 10" x 5"–9" ..... 1  
 Cyanoacrylate Wood Glue ..... Varies  
 Wood Screws #8 x  $1\frac{1}{2}$ " ..... As Needed

## Making a Narrow-Rip Push Block for an Auxiliary Fence

1. Cut a piece of  $\frac{3}{4}$ " thick plywood  $5\frac{1}{4}$ " wide and as long as your table saw fence; cut a piece of  $\frac{3}{4}$ " thick hardwood 3" wide and as long as your table saw fence, as shown in **Figure 75**.

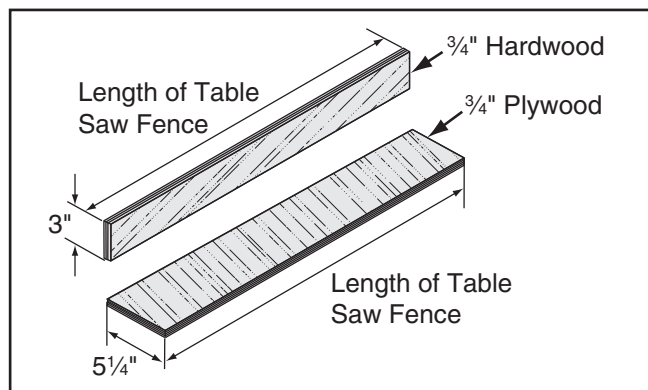

**Figure 75.** Auxiliary fence dimensions.

**Note:** We recommend cutting the hardwood board oversize, then jointing and planing it to the correct size to make sure the board is square and flat. Only use furniture-grade plywood or kiln dried hardwood to prevent warping.

2. Pre-drill and countersink eight pilot holes  $\frac{3}{8}$ " from the bottom of the 3" wide board, then secure the boards together with eight #8 x  $1\frac{1}{2}$ " wood screws, as shown in **Figure 76**.

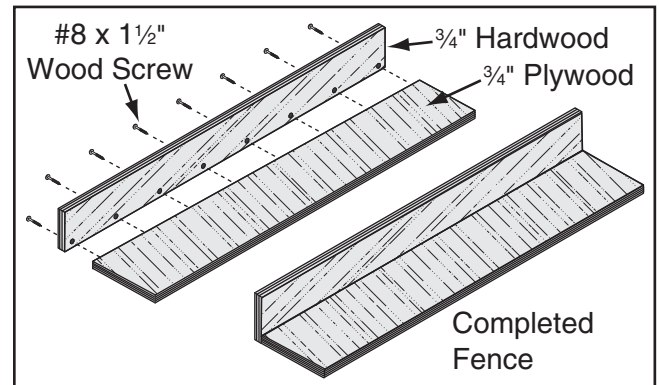

**Figure 76.** Location of pilot holes.

3. Using the  $\frac{3}{4}$ " material you used in the previous steps, cut out pieces for the push block per the dimensions shown in **Figure 77**; for the handle, cut a piece 10" long by 5"–9" high and shape it as desired to fit your hand.

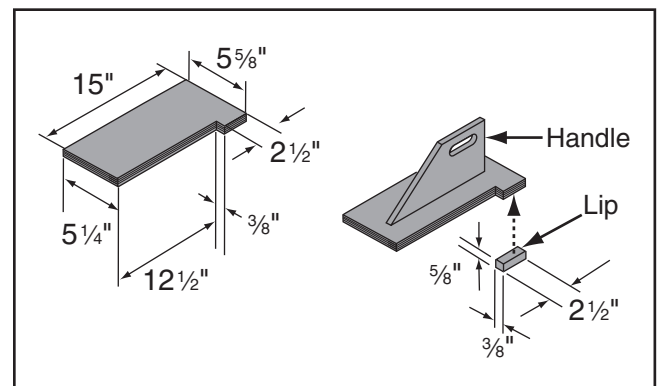

**Figure 77.** Push block dimensions and construction.

4. Attach the handle to the base with #8 x  $1\frac{1}{2}$ " wood screws, and attach the lip to the base with cyanoacrylate type wood glue.



## Using the Auxiliary Fence and Push Block

1. Place the auxiliary fence on the table and clamp it to the fence at both ends, then adjust the distance between the auxiliary fence and the blade—this determines how wide the workpiece will be ripped (see **Figure 78**).

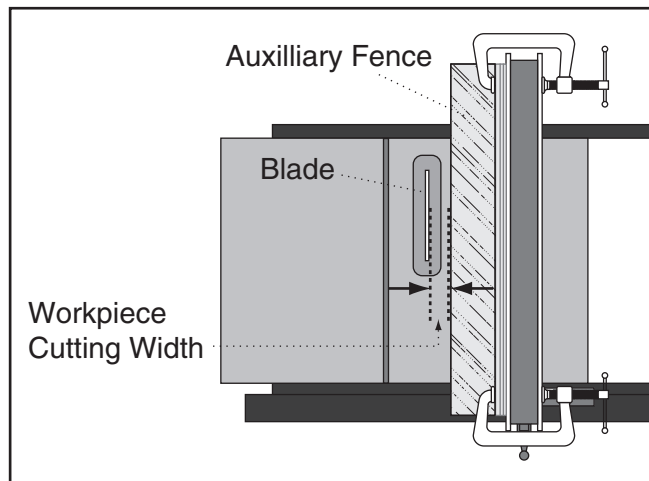

**Figure 78.** Adjusting ripping distance between blade and auxiliary fence.

2. Install the blade guard, then secure the spreader pawls in the upright position, as shown in **Figure 43** on **Page 34**, so they do not interfere with the push block lip.

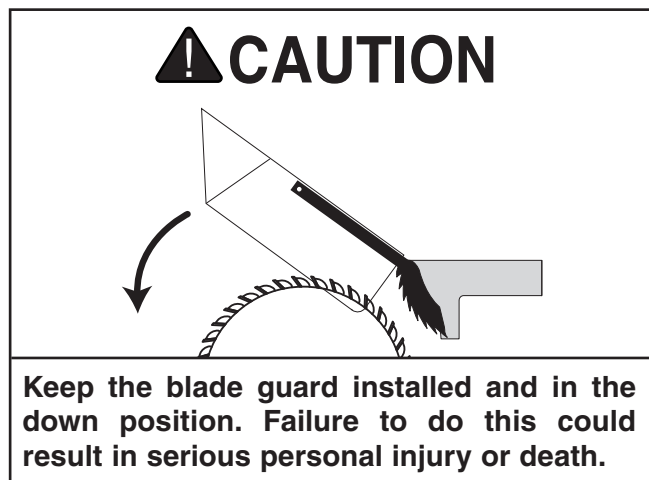

**Figure 79.** Push block in position to push workpiece through blade.

4. Turn the saw **ON**, then begin ripping the workpiece using a push stick for side support.
5. As the workpiece nears the end of the cut, place the push block on the auxiliary fence with the lip directly behind the workpiece, then release the push stick just before the blade.
6. Guide the workpiece the rest of the way through the cut with the push block, as shown in **Figure 80**.

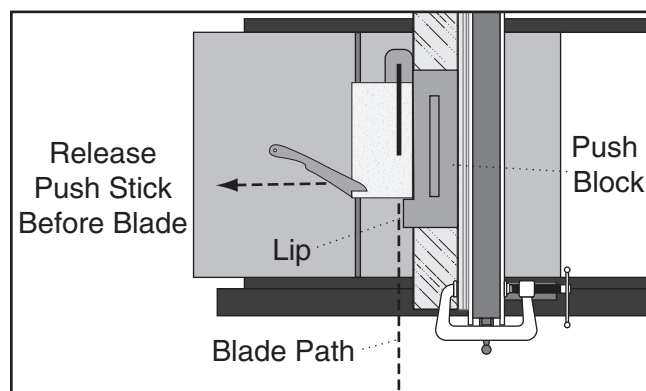

**Figure 80.** Ripping with push block.

3. Place the workpiece 1" behind the blade and evenly against the table and the auxiliary fence.



## CAUTION

Turn **OFF** the saw and allow the blade to come to a complete stop before removing the cut-off piece. Failure to follow this warning could result in serious personal injury.



# Outfeed & Support Tables

One of the best accessories for improving the safety and ease of using a table saw is simply placing a large table (outfeed table) behind the saw to catch the workpiece (see **Figure 81**). Additionally, another table to the left of the saw (support table) can also help support large workpieces so they can be cut safely and accurately.



**Figure 81.** Example of outfeed & support tables.

# Crosscut Sled

A crosscut sled (see **Figure 82**) is a fantastic way to improve the safety and accuracy of crosscutting on the table saw. Most expert table saw operators use a crosscut sled when they have to crosscut a large volume of work, because the sled offers substantial protection against kickback when crosscutting.



**Figure 82.** Example of crosscut sled.



# SECTION 6: AFTERMARKET ACCESSORIES FROM GRIZZLY

## **⚠ CAUTION**

Some aftermarket accessories can be installed on this machine that could cause it to function improperly, increasing the risk of serious personal injury. To minimize this risk, only install accessories recommended for this machine by Grizzly.

## **NOTICE**

Refer to the newest copy of the Grizzly Catalog for other accessories available for this machine.

**Call 1-800-523-4777 To Order**

### **H7583—Grizzly Tenoning Jig**

Our fully adjustable tenoning jig handles stock up to 3/4" thick and features an adjustable bevel angle with a 90° to 75° range. The two large grip handles, adjustable guide bar, multi-position control levers, and extra large clamping handwheel will ensure accurate and repeatable results. A top seller!

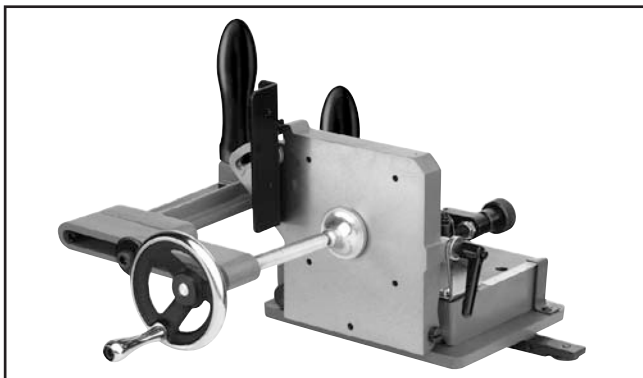

**Figure 83.** Model H7583 Tenoning Jig.

### **G7314Z—Heavy-Duty SHOP FOX® Mobile Base**

Make your Model G0715P mobile with this popular patented mobile base. The unique outrigger type supports increase stability and lower machine height. This heavy duty mobile base is rated for up to a 700 lb. capacity.

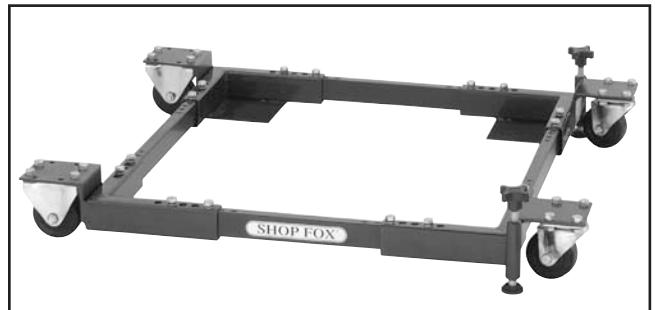
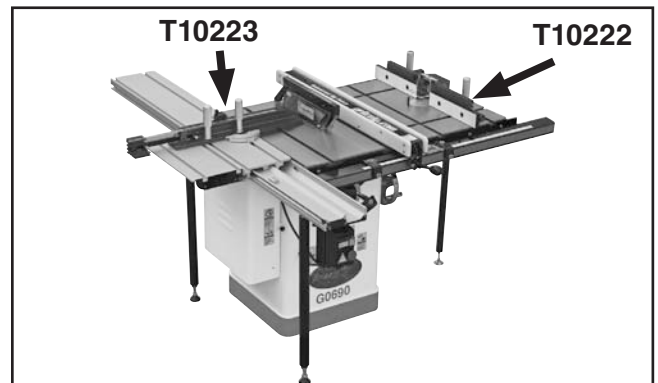

**Figure 84.** G7314Z SHOP FOX® Mobile Base.

### **T10222—Router Table Attachment**

### **T10223—Sliding Table Attachment**

Accessorize your Table Saw with either of these attachments for ultimate table saw functionality.



**Figure 85.** T10222-23 Sliding Table & Router Table Attachments.

### **T23146—Zero Clearance Insert for G0715P**





**G1317—37" Wide Outfeed Roller System**

**H8875—26" Wide Outfeed Roller System**

These unique roller systems fold down easily without tools and snap up in place quickly when needed. Both units have a double level system which lets you set the rollers either in line with the table or slightly below it.



**Figure 86.** Outfeed roller system.

**G5562—SLIPIT® 1 Qt. Gel**

**G5563—SLIPIT® 12 oz Spray**

**G2871—Boeshield® T-9 12 oz Spray**

**G2870—Boeshield® T-9 4 oz Spray**

**H3788—G96® Gun Treatment 12 oz Spray**

**H3789—G96® Gun Treatment 4.5 oz Spray**



**Figure 87.** Recommended products for protecting your cast iron table top.

**G1163—1HP Dust Collector**

**G3591—30 Micron Replacement Bag**

**H4043—3.0 Micron Upgrade Bag**

Excellent point-of-use dust collector that can be used next to the machine with minimal ducting. Specifications include 450 CFM, 2.8" static pressure, and 30 micron filter (upgradable to 3.0 micron). Features 1HP, 110V/220V, 14A/7A motor.



**Figure 88.** G1163 1HP dust collector.

**G4173—1/8 HP Power Feeder**

**G4176—1/4 HP Power Feeder**

**G4179—1/2 HP Power Feeder**

Installing a power feeder on your table saw will make repetitive cuts much easier and safer. Can be installed on nearly any table saw. Easy to adjust wherever needed, including out of the way when not needed! A must for any production shop.



**Figure 89.** G4179 Power Feeder.

**H3309—SHOP FOX® Featherboard**

Designed to lock into a standard 3/8" x 3/4" miter slot, this featherboard is fully adjustable to accommodate a wide range of workpieces.

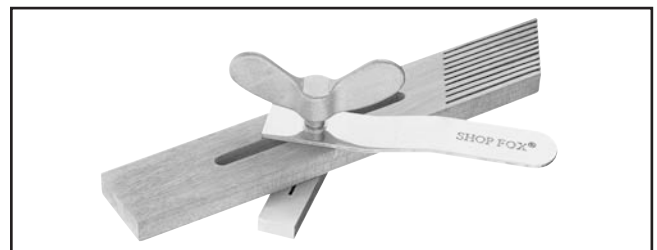

**Figure 90.** H3309 SHOP FOX® Featherboard.



### Forrest Woodworker II Saw Blades

**T20778—10", 20 Teeth**

**T20779—10", 40 Teeth**

**T23527—10", 48 Teeth**

Hailed as the Cadillac of all blades, Forrest saw blades have become legendary for their ability to leave highly polished, finish ready surfaces on nearly everything they cut. Made in USA.

With this all purpose blade for table saws you can rip and crosscut 1" 2" rockhards and softwoods resulting in a smooth as sanded surface. With 20° face hook, ply veneers will crosscut with no bottom splinter at moderate feed rates. Double hard and 40% stronger C4 carbide will give up to 300% longer life between sharpenings. Ends blade changing (one blade does rip, combo and crosscut), second-step finishing and cutting 1/16" oversize to allow for resurfacing. Buy and sharpen one blade instead of 3 (24T rip, 50T combination and 80T crosscut). 5/8" arbor, 1/8" kerf.

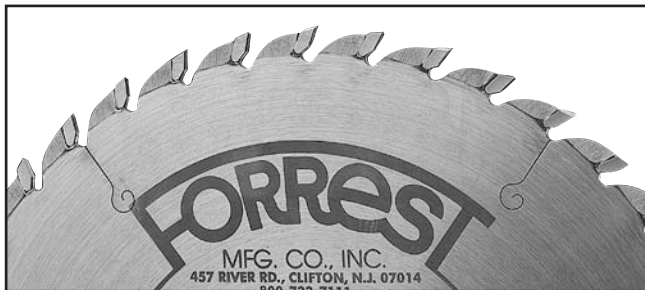

**Figure 91.** Forrest Woodworker II Saw Blade.

### Forrest Dado Blades

**H4756—8", 24 Teeth, 1/4"-29/32" Groove**

**T23267—8", 24 Teeth, 3/16"-1/4" Groove**

The world's finest dado head cleancuts all your grooves! No splintering when cross-cutting oak, ply veneers and melamine. Perfect for flat-bottomed grooves. No staggered steps or round bottoms like a wobble-dado leaves! Cuts in all directions - rip, cross-cut, miter, any depth. Cuts all sized grooves 1/4" through 29/32" increments.



**Figure 92.** H4756 Dado Head.

**H1052—Clear Flexible Hose 4" x 10'**

**G1536—Black Flexible Hose 4" x 10'**

**G3179—Heavy-Duty Clear Flex Hose 4" x 10'**

**G8830—Hose Hanger 4 1/2"**

**G1552—Y-Fitting 4" x 4" x 4"**

**G1545—90° Elbow 4"**

**G2482—Hose Coupler (Splice) 4"**

**G2974—Wire Hose Clamp 4"**

**G1843—Plastic Blast Gate 4"**

**G4679—Anti-Static Grounding Kit**

We've hand picked a selection of commonly used dust collection components for machines with 4" dust ports.



**Figure 93.** Dust collection accessories.

### T20392—Success with Tablesaws

The tablesaw is the cornerstone of any workshop, yet, too many woodworkers still haven't learned just how versatile this tool really is. This indispensable handbook explains how to choose and set up the right saw for any shop, and demonstrates basic and advanced techniques for ripping, crosscutting, and cutting bevels and mitered edges. 176 pgs.

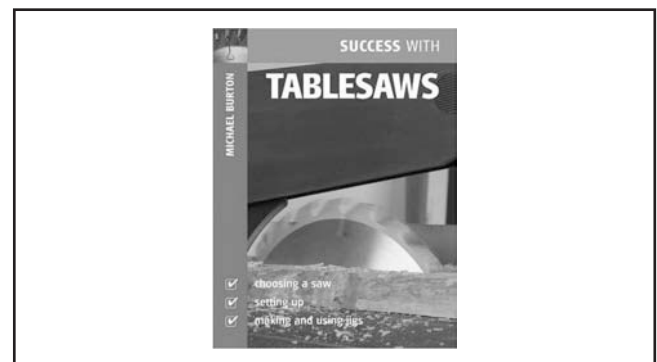

**Figure 94.** Model T20392 Success with Tablesaws guide book.



# SECTION 7: MAINTENANCE

---

---

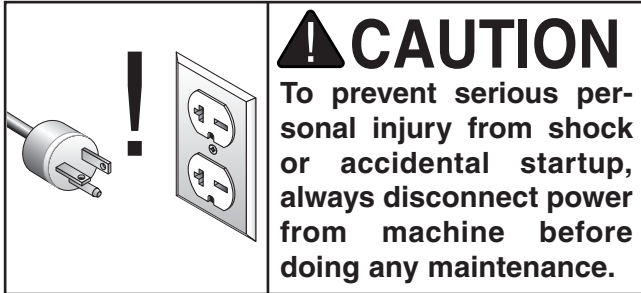

## Schedule

---

---

The frequency of maintenance necessary for any machine will always depend on the operating conditions and environment. The schedule below is a basic guideline for keeping your machine in proper operating condition. Always repair any adverse conditions immediately upon discovery.

### Daily (Ongoing)

- Inspect blades for damage or wear.
- Check for loose mounting bolts/arbor nut.
- Check cords, plugs, and switch for damage.
- Check for any other condition that could hamper the safe operation of this machine.
- Wipe the table clean after every use—this ensures moisture from wood dust does not remain on bare metal surfaces.

### Weekly

- Wipe down the table surface and grooves with a lubricant and rust preventive such as SLIPIT®.
- Vacuum dust buildup from the motor housing and trunnions.
- Clean the pitch and resin from the saw blade with a cleaner such as OxiSolv® Blade & Bit Cleaner.

### Monthly

- Check V-belt tension, damage, or wear (**Page 71**).

### Every 6–12 Months

- Lubricate the trunnions (**Page 58**).
- Lubricate the elevation and tilt leadscrews (**Page 58**).

## Cleaning

---

---

Cleaning the table saw is relatively easy. Vacuum excess wood chips and sawdust from the table saw and inside the cabinet. Wipe off the remaining dust with a dry cloth.

Use compressed air (make sure to wear safety glasses and a respirator when doing this) to blow dust from the machine. If any resin has built up, use a resin-dissolving cleaner to remove it. Treat all unpainted cast iron and steel with a non-staining lubricant after cleaning.

## Unpainted Cast Iron

---

---

Protect the unpainted cast iron surfaces on the table by wiping the table clean after every use—this ensures moisture from wood dust does not remain on bare metal surfaces. **DO NOT** clean cast iron with water or it will rust!

Keep tables rust-free with regular applications of products like G96® Gun Treatment, SLIPIT®, or Boeshield® T-9 (see **Page 55** for more details).



# Lubrication

It is essential to clean components before lubricating them because dust and chips build up on lubricated components and make them hard to move. Simply adding more grease to them will not yield smooth moving components.

Clean the components in this section with an oil/grease solvent cleaner and shop rags.

If you thoroughly clean the components in this section before lubricating them, the result will be silky smooth movement when turning the handwheels, which will result in much higher enjoyment on your part!

**The following are the main components that need to be lubricated:**

- Trunnion Slides and Orientation Gears
- Worm Gears, Trunnion, and Bearing Housing Teeth

## Trunnion Slides

Clean out the front and rear trunnion slides with mineral spirits and a rag, then apply lithium grease into each groove. Move the blade tilt back-and-forth to spread the grease (see **Figure 95**).



**Figure 95.** Trunnion slide (only front slide shown).

## Worm Gear, Bull Gear & Leadscrew

Clean away any built up grime and debris from the worm gear, bull gear, and leadscrew (see **Figures 96–97**) with a wire brush, rags, and mineral spirits. Allow the components to dry, then apply a thin coat of white lithium grease to them.

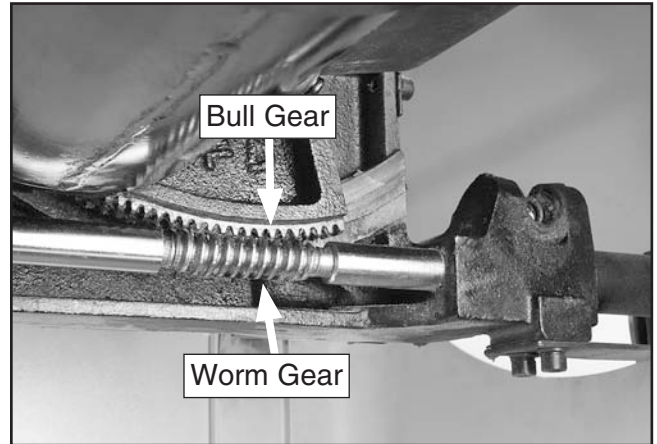

**Figure 96.** Worm and bull gear.

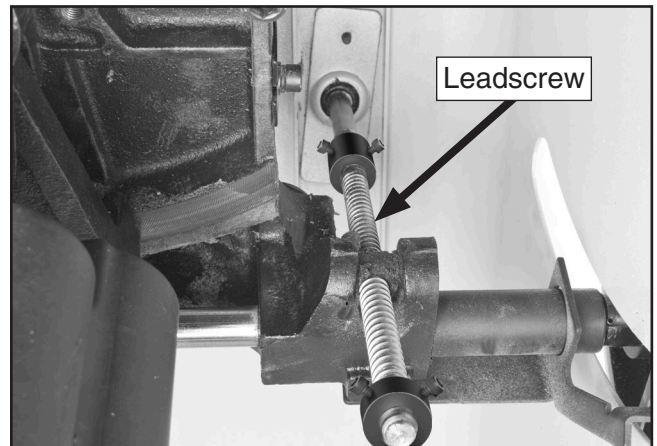

**Figure 97.** Leadscrew.



# SECTION 8: SERVICE

Review the troubleshooting and procedures in this section if a problem develops with your machine. If you need replacement parts or additional help with a procedure, call our Technical Support at (570) 546-9663.

**Note:** Please gather the serial number and manufacture date of your machine before calling.

## Troubleshooting

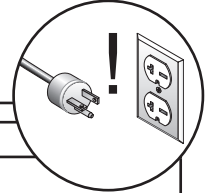

Symptom	Possible Cause	Possible Solution
Machine does not start or a breaker trips.	<ol style="list-style-type: none"> <li>1. Locking pin installed.</li> <li>2. Blown fuse.</li> <li>3. Wall circuit breaker tripped.</li> <li>4. Power supply switched OFF or at fault.</li> <li>5. Plug/receptacle at fault/wired wrong.</li> <li>6. Motor connection wired wrong.</li> <li>7. Wiring open/has high resistance.</li> <li>8. Motor START/STOP switch at fault.</li> <li>9. Start capacitor at fault.</li> <li>10. Motor at fault.</li> </ol>	<ol style="list-style-type: none"> <li>1. Remove locking pin from START button.</li> <li>2. Replace fuse/ensure no shorts.</li> <li>3. Ensure circuit size is correct/replace weak breaker.</li> <li>4. Ensure power supply is on/has correct voltage.</li> <li>5. Test for good contacts; correct the wiring.</li> <li>6. Correct motor wiring connections.</li> <li>7. Check/fix broken, disconnected, or corroded wires.</li> <li>8. Replace switch.</li> <li>9. Test/replace if faulty.</li> <li>10. Test/repair/replace.</li> </ol>
Machine stalls or is underpowered.	<ol style="list-style-type: none"> <li>1. Feed rate/cutting speed too fast.</li> <li>2. Workpiece material unsuitable for machine.</li> <li>3. Workpiece crooked; fence mis-adjusted.</li> <li>4. Machine undersized for task; wrong blade.</li> <li>5. Run capacitor at fault.</li> <li>6. Belt slipping.</li> <li>7. Motor wired incorrectly.</li> <li>8. Plug/receptacle at fault.</li> <li>9. Pulley/sprocket slipping on shaft.</li> <li>10. Motor bearings at fault.</li> <li>11. Contactor not energized/has poor contacts.</li> <li>12. Motor overheated.</li> <li>13. Motor at fault.</li> </ol>	<ol style="list-style-type: none"> <li>1. Decrease feed rate/cutting speed.</li> <li>2. Only cut wood/ensure moisture is below 20%.</li> <li>3. Straighten or replace workpiece/adjust fence.</li> <li>4. Use correct blade/reduce feed rate or depth of cut.</li> <li>5. Test/repair/replace.</li> <li>6. Tension/replace belt (<b>Page 71</b>).</li> <li>7. Wire motor correctly.</li> <li>8. Test for good contacts/correct wiring.</li> <li>9. Replace loose pulley/shaft.</li> <li>10. Test/repair/replace.</li> <li>11. Test all legs for power/replace if faulty.</li> <li>12. Clean motor, let cool, and reduce workload.</li> <li>13. Test/repair/replace.</li> </ol>
Machine has vibration or noisy operation.	<ol style="list-style-type: none"> <li>1. Motor or component loose.</li> <li>2. Blade at fault.</li> <li>3. Belts worn or loose.</li> <li>4. Pulley loose.</li> <li>5. Motor mount loose/broken.</li> <li>6. Machine incorrectly mounted.</li> <li>7. Arbor pulley loose.</li> <li>8. Motor fan rubbing on fan cover.</li> <li>9. Arbor bearings at fault.</li> <li>10. Motor bearings at fault.</li> </ol>	<ol style="list-style-type: none"> <li>1. Inspect/replace damaged bolts/nuts, and re-tighten with thread locking fluid.</li> <li>2. Replace warped/bent blade; sharpen dull blade.</li> <li>3. Tension/replace belts (<b>Page 71</b>).</li> <li>4. Realign/replace shaft, pulley, setscrew, and key.</li> <li>5. Tighten/replace.</li> <li>6. Tighten mounting bolts; relocate/shim machine.</li> <li>7. Retighten/replace arbor pulley.</li> <li>8. Fix/replace fan cover; replace loose/damaged fan.</li> <li>9. Replace arbor housing bearings; replace arbor.</li> <li>10. Test by rotating shaft; grinding/loose shaft requires bearing replacement.</li> </ol>



Symptom	Possible Cause	Possible Solution
Blade is not aligned with miter slot or fence.	<ol style="list-style-type: none"> <li>1. Blade is warped.</li> <li>2. Table top is not parallel to blade.</li> <li>3. Fence is not parallel to blade.</li> </ol>	<ol style="list-style-type: none"> <li>1. Replace blade (<b>Page 31</b>).</li> <li>2. Make table parallel to blade (<b>Page 63</b>).</li> <li>3. Make fence parallel to blade (<b>Page 68</b>).</li> </ol>
Blade does not reach 90°.	<ol style="list-style-type: none"> <li>1. 90° stop collar is out of adjustment.</li> <li>2. Sawdust stuck on stop collar.</li> </ol>	<ol style="list-style-type: none"> <li>1. Adjust 90° stop collar (<b>Page 61</b>).</li> <li>2. Clean sawdust off stop collar.</li> </ol>
Blade hits insert at 45°.	<ol style="list-style-type: none"> <li>1. 45° stop collar is out of adjustment.</li> <li>2. Sawdust stuck on stop collar.</li> <li>3. Slot in insert is inadequate.</li> <li>4. Table out of alignment.</li> <li>5. Blade position is incorrect.</li> </ol>	<ol style="list-style-type: none"> <li>1. Adjust 45° stop collar (<b>Page 61</b>).</li> <li>2. Clean sawdust off stop collar.</li> <li>3. File or mill the slot in the insert.</li> <li>4. Align blade to the table (<b>Page 63</b>).</li> <li>5. Adjust blade position.</li> </ol>
Board binds or burns when feeding through table saw.	<ol style="list-style-type: none"> <li>1. Dull blade.</li> <li>2. Blade is warped.</li> <li>3. Fence is not parallel to blade.</li> <li>4. Table top is not parallel to blade.</li> </ol>	<ol style="list-style-type: none"> <li>1. Replace blade (<b>Page 31</b>).</li> <li>2. Replace blade (<b>Page 31</b>).</li> <li>3. Make fence parallel to blade (<b>Page 68</b>).</li> <li>4. Make table parallel to blade (<b>Page 63</b>).</li> </ol>



# Blade Tilt Stops

The table saw features stop collars that stop the blade exactly at 45° and 90° when tilting it with the handwheel. The stops have been set at the factory and should require no adjustments, unless you notice that your cuts are not accurate.

**Note:** The tilt scale reads "0" when the blade is 90° to the table.

Tools Needed	Qty
90° Square .....	1
45° Square .....	1
Hex Wrench 4mm.....	1

## Setting 90° Stop Collar

1. DISCONNECT SAW FROM POWER!
2. Raise the blade as high as it will go, then tilt it toward 0° until it stops and cannot be tilted any more.
3. Place a 90° square against the table and blade so it contacts the blade evenly from bottom to top, as shown in **Figure 98**. Make sure a blade tooth does not obstruct the placement of the square.

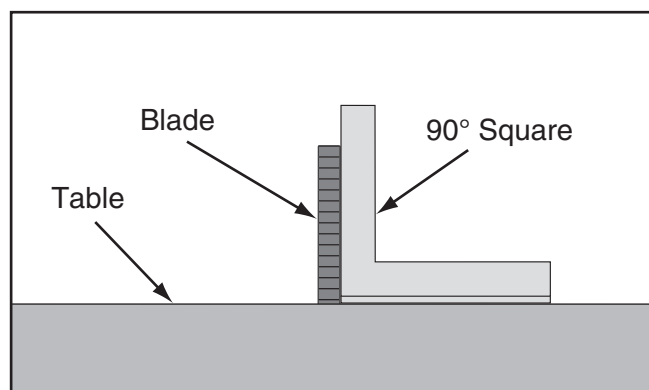

**Figure 98.** Checking blade at 90°.

—If the blade is 90° to the table, then adjustments do not need to be made. Make sure the tilt indicator arrow shown in **Figure 99** points to the 0° mark on the scale. Adjust the position by loosening the button head screw, moving the indicator with your fingers, then tightening the screw.

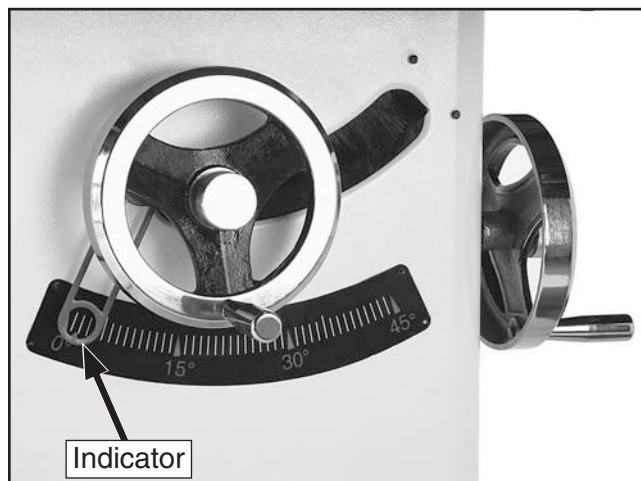

**Figure 99.** Tilt indicator arrow.

—If the blade is not 90° to the table, you will need to adjust the 90° stop collar. Proceed to the next step.

4. Tilt the blade away from 0° by about 5°, so there is room for the 90° stop collar to move.
5. Open the motor access cover, loosen the cap screws shown in **Figure 100**, then thread the 90° stop collar one turn away from the trunnion bracket. This will allow you to square the blade in the next step.

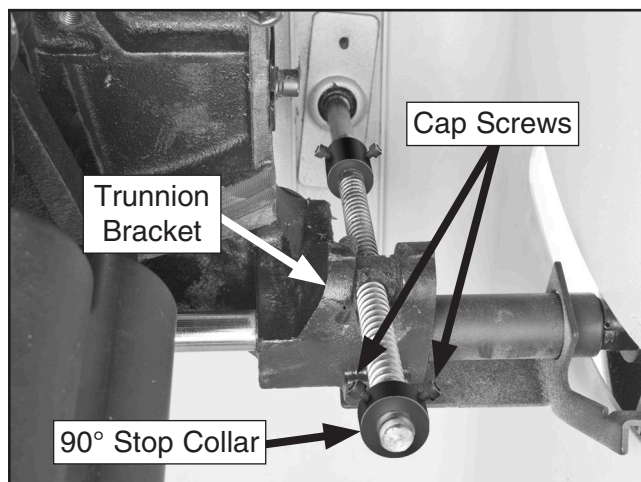

**Figure 100.** 90° stop bolt and jam nut.

6. Place a square against the blade, as shown in **Figure 98**, then adjust the blade until it is perfectly square to the table.
7. Without turning the blade tilt leadscrew, finger-tighten the 90° collar against the trunnion bracket, then tighten the two cap screws to secure the collar position.



8. Repeat **Steps 2–3** to verify that the collar adjustment you made was correct. When the adjustment is satisfactory, close the motor access cover.

## Setting 45° Stop Collar

1. DISCONNECT SAW FROM POWER!
2. Raise the blade as high as it will go, then tilt it towards 45° until it stops and cannot be tilted any more.
3. Place a 45° square against the table and blade so it contacts the blade evenly from bottom to top, as shown in **Figure 101**. Make sure a blade tooth does not obstruct the placement of the square.

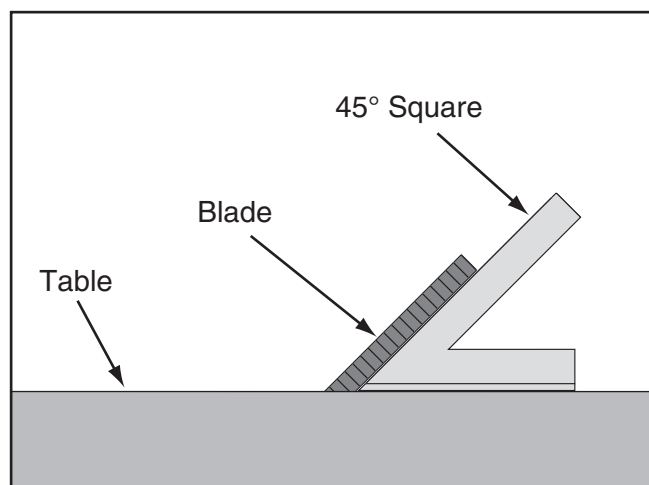

**Figure 101.** Checking blade at 45°.

—If the blade is 45° to the table, then adjustments do not need to be made.

—If the blade is not 45° to the table, you will need to adjust the 45° stop collar. Proceed to the next step.

4. Tilt the blade to 35°, so there is room for the stop collar to move.

5. Open the motor access cover, loosen the cap screws on the 45° stop collar (see **Figure 102**), then turn the collar one turn away from the trunnion bracket. This will allow you to adjust the blade to exactly 45° in the next step.

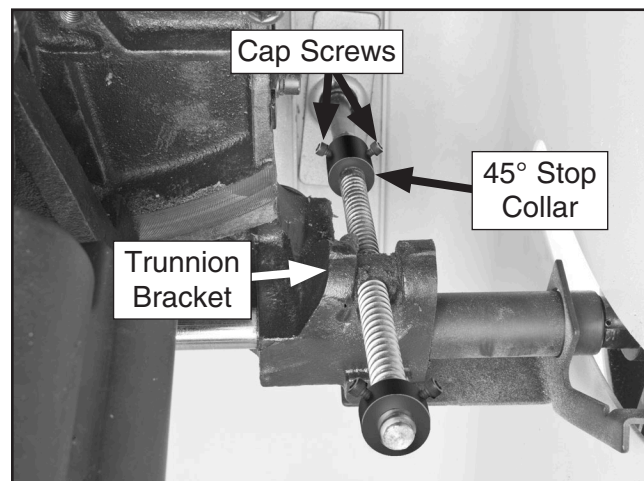

**Figure 102.** 45° stop collar.

6. Place a 45° square against the blade, as shown in **Figure 101**, then adjust the blade until it is exactly 45° to the table.
7. Without turning the blade tilt leadscrew, finger-tighten the 45° stop collar against the trunnion bracket, then tighten the two cap screws to secure the collar position.
8. Repeat **Steps 2–3** to verify that the collar adjustment you made was correct. When the adjustment is satisfactory, close the motor access cover.





# Miter Slot to Blade Parallelism

Your table saw will give the best results if the miter slot and the rip fence are adjusted parallel to the blade. If either of these are not exactly parallel, your cuts and your finished work will be lower in quality, but more importantly, the risk of kickback will be increased.

Tools Needed	Qty
Adjustable Square .....	1
Marker .....	1
Rubber Dead Blow Hammer .....	1
Hex Wrenches 3, 8 mm.....	1 Each

## To adjust the blade parallel to the miter slot:

1. DISCONNECT SAW FROM POWER!
2. Use an adjustable square to measure the distance from the miter slot to a carbide tip on the blade, as shown in **Figure 103**. Make sure that the face of the adjustable square is even along the miter slot.

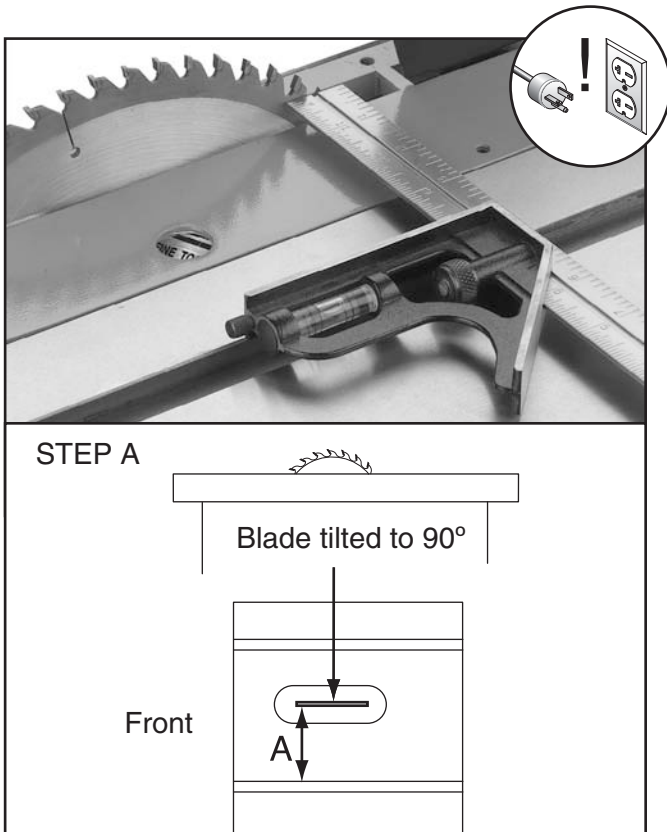

**Figure 103.** Example of adjusting blade to miter slot.

3. With the end of the adjustable square just touching the tip, lock the square in place. Now, mark the carbide tip with a marker where you made this measurement.

**⚠ CAUTION**

**The saw blade is sharp. Use extra care or wear gloves when handling the blade or working near it.**

4. Rotate the marked blade tip to the other end of the table insert.
5. Slide the adjustable square down to the other end of the table insert, and compare the distance from the marked blade tip to the end of the adjustable square, as shown in **Figure 104**.

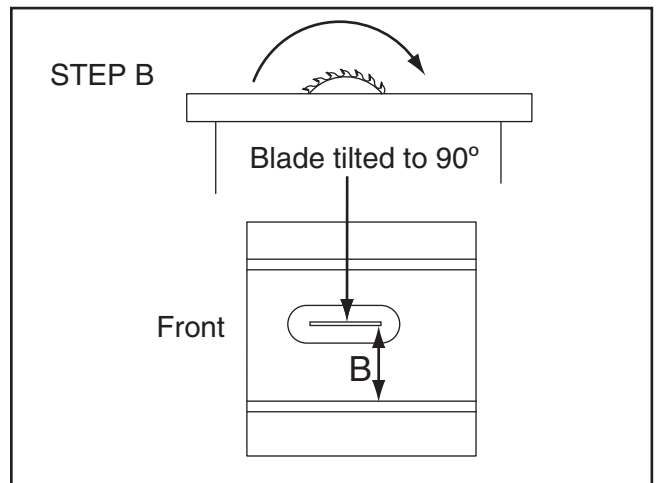

**Figure 104.** Measuring distance from miter slot to carbide tip on opposite side of table insert.

—If the blade tip measurement is the same on both sides, go to **Step 11**.

—If the blade tip does not touch the end of the adjustable square similar to the first measurement, the table will need to be adjusted. Proceed to **Step 6**.



## CAUTION

The trunnion and motor assembly could fall and crush your hands or arms if the trunnion mounting cap screws are loosened too much during the following steps. DO NOT remove the cap screws that secure the trunnions to the table or loosen them more than 1½ turns!

6. Remove the six button head cap screws that secure the rear trunnion access panel (see **Figure 105**), remove the panel, and open the door cabinet to access the trunnions.

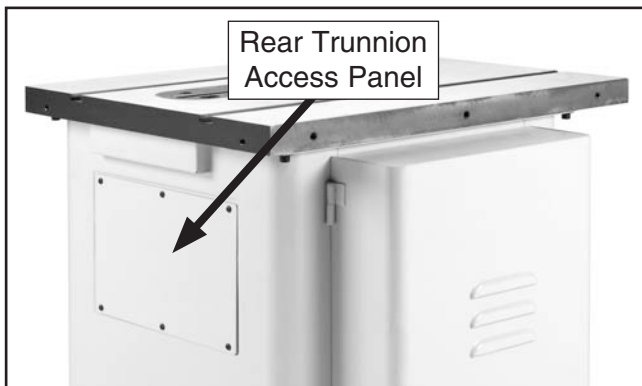

**Figure 105.** Rear trunnion access panel.

7. To adjust the table, loosen the two cap screws that secure the rear trunnion to the underside of the table 1–1½ turns (see **Figure 106**), and slightly tap the trunnion with a rubber dead blow hammer in the needed direction.
8. Tighten the two cap screws and recheck the miter slot-to-blade parallelism, as you did in **Steps 2–5**.

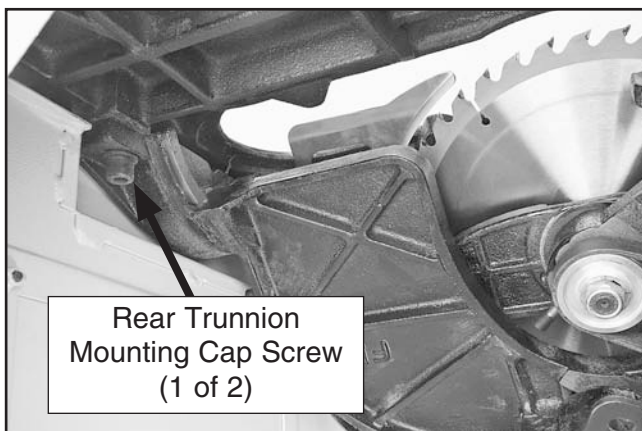

**Figure 106.** Rear trunnion mount cap screw.

- If the measurement is the same from front-to-back, skip ahead to **Step 11**.
- If the adjustments you made in **Step 7** were not enough to adjust the miter slot parallel to the blade, continue to **Step 9**.

9. Loosen the two cap screws that secure the front trunnion to the underside of the table (see **Figure 107**) and tap the trunnion in a similar manner as you did in **Step 7**.

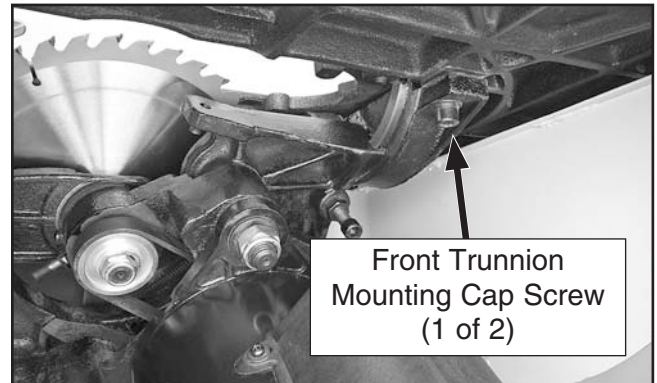

**Figure 107.** Front trunnion mounting screw.

10. Tighten the two cap screws and recheck the miter slot-to-blade parallelism.
  - If the blade tip measurement is the same on both sides, continue to **Step 11**.
  - If the adjustments you made in **Step 9** were not enough to adjust the miter slot parallel with the blade, continue adjusting the front and rear trunnions as needed until the miter slot and blade are parallel.
11. Tilt the blade to 45° and recheck the miter slot-to-blade parallelism.
  - If the blade is still parallel with the miter slot, no additional adjustments need to be made. Skip ahead to **Step 15**.
  - If the blade was parallel with the miter slot at 90° but not at 45°, continue to **Step 12**.



- Depending on the result of **Step 11**, loosen the front or rear trunnion cap screws  $1\frac{1}{2}$  turns and remove 1 shim from each side of that trunnion.

Refer to **Figures 108–109** to determine where to remove shims from the trunnions.

—If the distance of A is greater than B, remove one shim from each side of the front trunnion (#1 and #2 on **Figure 108**).

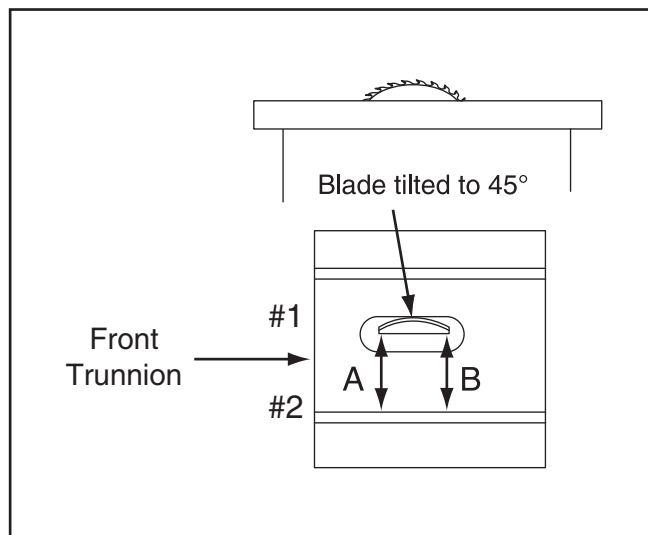

**Figure 108.** Shim removal procedure diagram A.

—If the distance of B is greater than A, remove one shim from each side of the rear trunnion (#3 and #4 on **Figure 109**).

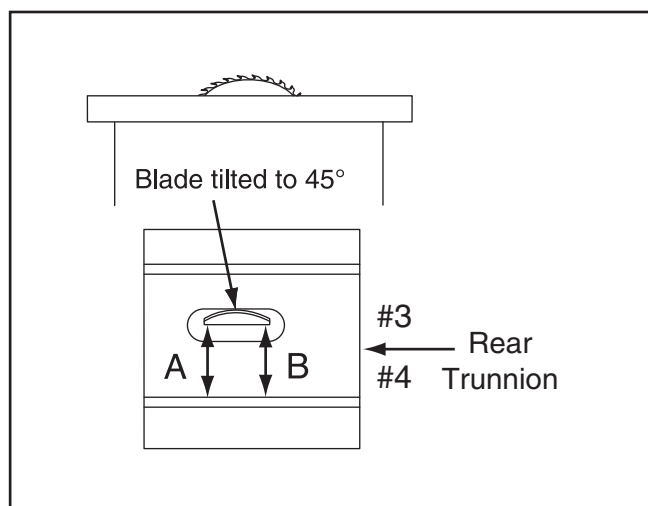

**Figure 109.** Shim removal procedure diagram B.

- Tighten the cap screws and recheck the blade-to-miter slot parallelism at  $90^\circ$  and  $45^\circ$ .

—If the distance of A and B are equal, no further adjustments need to be made.

—If the distances of A and B are not equal, recheck the miter slot-to-blade parallelism.

- Once the miter slot is adjusted parallel to the blade, recheck all measurements and be sure the table mounting caps screws are secure.
- Re-install the rear trunnion access panel and close the cabinet door.



# Spreader or Riving Knife Alignment

## Checking Alignment

The blade guard spreader and riving knife must be aligned with the blade when installed. If the spreader/riving knife is not aligned with the blade, then the workpiece will be forced sideways during the cut, which will increase the risk of kick-back.

Tools Needed	Qty
Straightedge .....	1

### To check the spreader/riving knife alignment:

1. DISCONNECT SAW FROM POWER!
2. Raise the saw blade to the maximum height so you have easy working access.
3. Place the straightedge against the side of the blade and spreader/riving knife at the top and bottom, as shown in **Figure 110**. The spreader/riving knife should be parallel with the blade along its length at both positions, and in the "Alignment Zone," as shown in **Figure 111**.

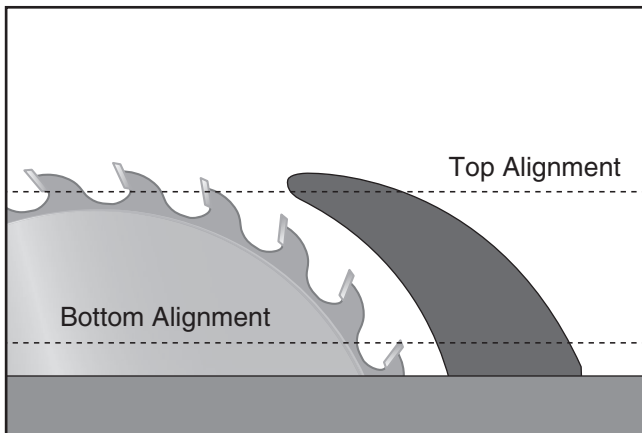

**Figure 110.** Checking top and bottom riving knife parallelism with blade.

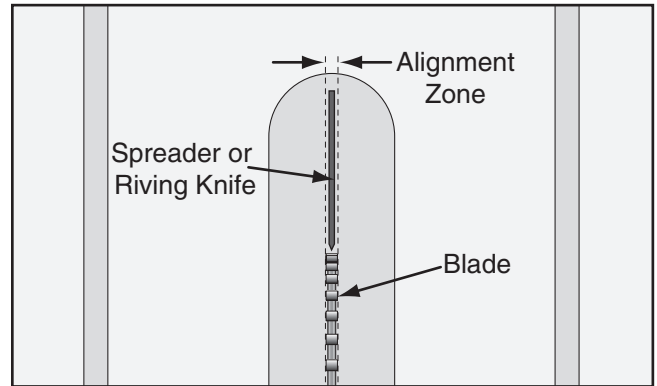

**Figure 111.** Spreader/riving knife alignment zone.

—If the spreader/riving knife is not parallel with the blade and inside the alignment zone, then it needs to be adjusted. Proceed to **Adjusting Alignment** instructions.

—If the spreader/riving knife is not parallel with the blade at either the top or bottom, it may be bent.

4. Remove the spreader/riving knife and place it on a flat surface and check to see if the spreader/riving knife lays evenly along its length.

—If the spreader/riving knife does not lay evenly, proceed to **Adjusting Bent Spreader/Riving Knife** on **Page 67**.

## Adjusting Alignment

The spreader/riving knife mounting position can be adjusted into alignment with the blade using the cap screws on the spreader/riving knife "L" bracket.

Possible Tools Needed	Qty
Hex Wrench 5mm.....	1

### To adjust the spreader/riving knife position:

1. DISCONNECT SAW FROM POWER!
2. Remove the table insert.



- Loosen the two cap screws on the "L" bracket (see **Figure 112**), then slide it as needed to move it into alignment with the blade.

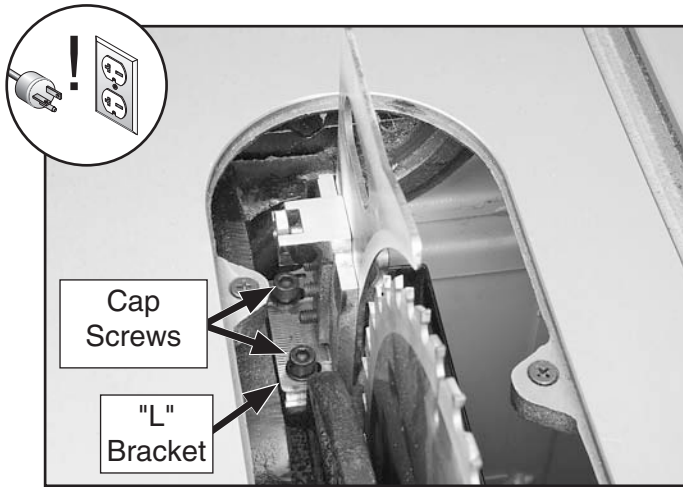

**Figure 112.** Cap screws for adjusting spreader/ripping knife position.

- Follow **Checking Alignment, Steps 1–3**.
  - If the spreader/ripping knife is in the alignment zone, no additional steps are necessary.
  - If the spreader/ripping knife is still not in the alignment zone, continue adjusting the position of the "L" bracket as necessary to correctly align the spreader/ripping knife.
- Tighten the two cap screws on the mounting block to secure the spreader/ripping knife adjustment.

## Adjusting Bent Spreader/Ripping Knife

- DISCONNECT SAW FROM POWER!
- Bend the spreader or ripping knife by hand while installed, then follow **Steps 1–3** in **Checking Alignment** to determine if it is parallel with the blade and inside the "Alignment Zone" (refer to **Checking Alignment**).
  - If this does not work, remove it to straighten.
  - If you cannot straighten it properly, replace it.

# Fence Adjustments

There are four main adjustments for the fence: height off the table, squareness, parallelism with the miter slot, and clamping pressure. These adjustments are interconnected and some repetition may be needed when adjusting.

<b>Tools Needed</b>	<b>Qty</b>
Hex Wrench 6mm.....	1
Square.....	1
Felt-Tipped Marker .....	1

## Height and Square

The fence should be adjusted high enough off the table so that it does not drag across the surface or allow wood chips to get caught between the fence and table. Also, the fence face must be square to the table in order to produce accurate cuts.

### To check/adjust the fence height and squareness to the table:

- DISCONNECT SAW FROM POWER!
- Remove the fence from the saw and place it on a flat surface.
- Unscrew the front thumb knobs and set screws shown in **Figure 113** until they are barely threaded into the fence flange.

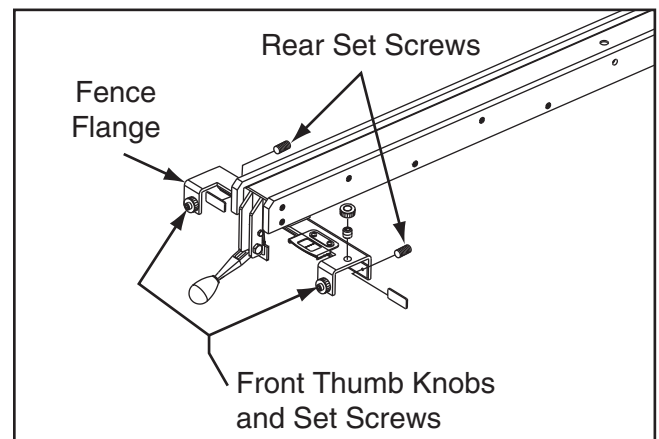
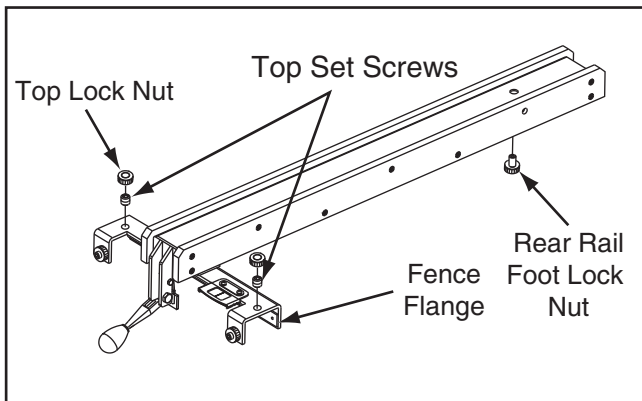

**Figure 113.** Location of set screws used to adjust fence parallelism and clamping pressure.

- Back out the rear set screws until they are just threaded into the fence flange (see **Figure 113**).



5. Install the fence onto the table.
6. Loosen the top lock nuts on the fence flange and the lock nut on the rear rail foot, shown in **Figure 114**.



**Figure 114.** Fence components used to adjust fence height and squareness to table.

7. Adjust the top set screws and rear foot set screw so there is approximately  $\frac{1}{16}$ " clearance between the bottom of the fence and the table, front-to-back and side-to-side, then tighten the lock nuts.
8. Place a square on the table and against the face of the fence, as shown in **Figure 115**, to check if the fence is square to the table.
  - If the fence is square to the table, proceed to **Parallelism & Clamping Pressure**.
  - If the fence is not square to the table, proceed to **Step 9**.

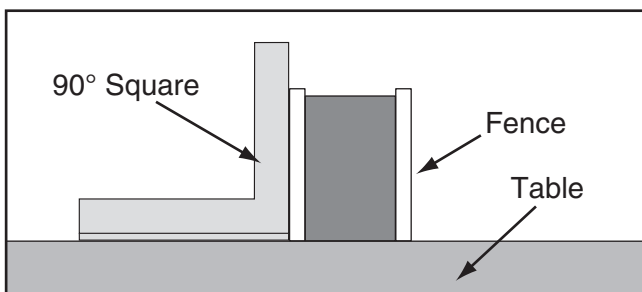

**Figure 115.** Checking if fence is square to table.

9. Loosen the top lock nuts and adjust the top set screws (see **Figure 114**) to make the fence face  $90^\circ$  to the table, then tighten the lock nuts.

## Parallelism & Clamping Pressure

Set screws on the rear side of the fence flange position the fence parallel to the blade and adjust the clamping pressure to hold your fence securely. Before starting this procedure, make sure the blade is parallel with the miter slot.

### To adjust the fence parallelism and clamping pressure:

1. DISCONNECT SAW FROM POWER!
2. Lock the fence, tap the front side with your fist, and check to see if it moved sideways over the table.
  - If the fence did not move, proceed to **Step 5**.
  - If the fence moved, remove it from the table and proceed to **Step 3**.
3. Turn each rear set screw (see **Figure 113** on **Page 67**) in  $\frac{1}{6}$ th of a turn.
4. Re-install the fence and repeat **Step 2**.
5. Slide the fence up against the right-hand edge of the miter slot, as shown in **Figure 116**, and lock it in place.

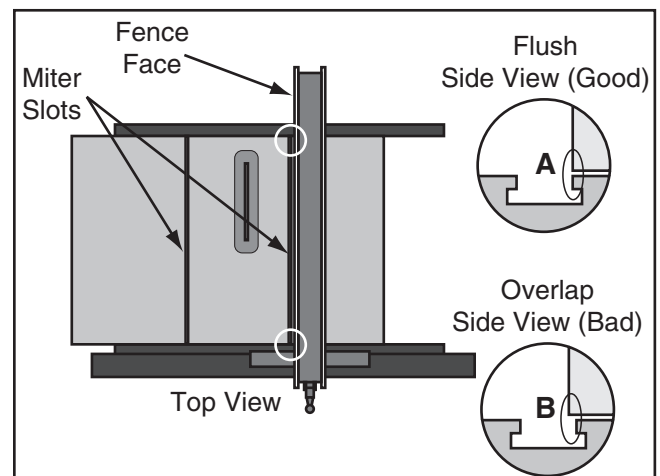

**Figure 116.** Aligning fence to miter slot.



6. Examine how the fence lines up with the miter slot along its length.

—If the fence and miter slot are flush from front to rear, as shown in **Figure 116A**, proceed to **Step 8**.

—If the rear of the fence overlaps the miter slot, as shown in **Figure 116B**, the fence is misaligned. Proceed to **Step 7**.

7. Remove the fence, then alternately loosen and tighten the rear fence set screws in equal amounts to adjust the rear of the fence until it is parallel with the miter slot.

8. Loosen both front thumb knobs (see **Figure 113** on **Page 67**). Tighten the set screws so they just touch the fence tube, back off the set screws  $\frac{1}{2}$  turn, then tighten the thumb knobs.

## Optional Offset Fence Adjustment

Some woodworkers prefer to offset the rear of the fence  $\frac{1}{64}$ " from the blade, as shown in **Figure 117**, to help prevent the workpiece from binding and burning.

The argument is that this offset adjustment reduces the chance of kickback by alleviating potential binding that may occur between the backside of the blade and fence. The tradeoff is slightly less accurate cuts.

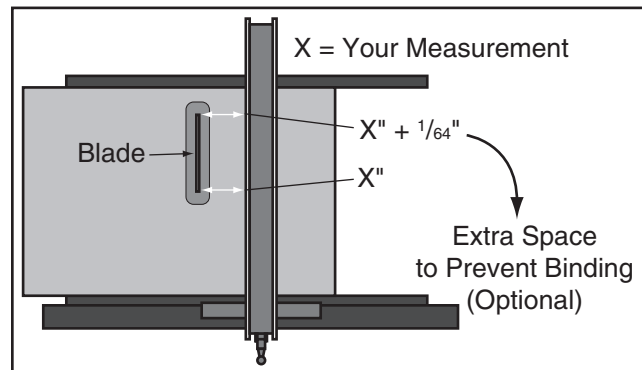

**Figure 117.** Adjusting fence with a  $\frac{1}{64}$ " offset.

### To offset the fence:

1. DISCONNECT SAW FROM POWER!
2. With a felt tip pen, mark one saw tooth and rotate the blade so this tooth is positioned at the back of the blade.
3. Place the fence on the table, and clamp the fence to the table.
4. Measure the distance between the tooth and the fence face, as shown in **Figure 117**.
5. Remove the fence, and adjust the rear set screws as previously discussed to achieve an offset of  $\frac{1}{64}$ " between the marked tooth and the fence face.
6. Re-install the fence and measure the distance again between the marked tooth and the fence face. The rear measurement should be  $\frac{1}{64}$ " greater than previously measured in **Step 4**.



# Miter Gauge Adjustments

The miter gauge is equipped with stop screws that allow you to easily adjust the miter gauge 0°–30° left, 90°, and 0°–45° right. The stop screws contact the shaft, which moves in or out of the way for adjustments.

Tools Needed	Qty
Phillips Head Screwdriver.....	1
90° Square .....	1
45° Square .....	1
30° Square .....	1
Wrench 8mm .....	1

## Checking/Setting 90° Stops

1. DISCONNECT SAW FROM POWER!
2. Slide the miter gauge into the T-slot on the table.
3. Adjust the miter gauge so the 90° stop screw rests against the sliding shaft.
4. Place the square evenly against the face of the miter gauge and the blade, as shown in **Figure 118**.

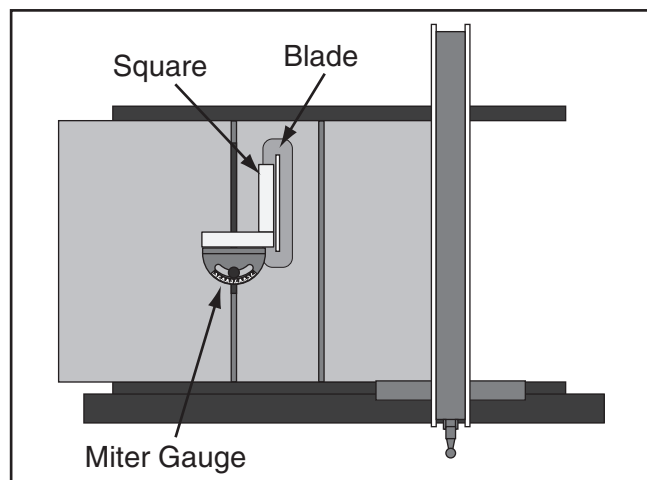
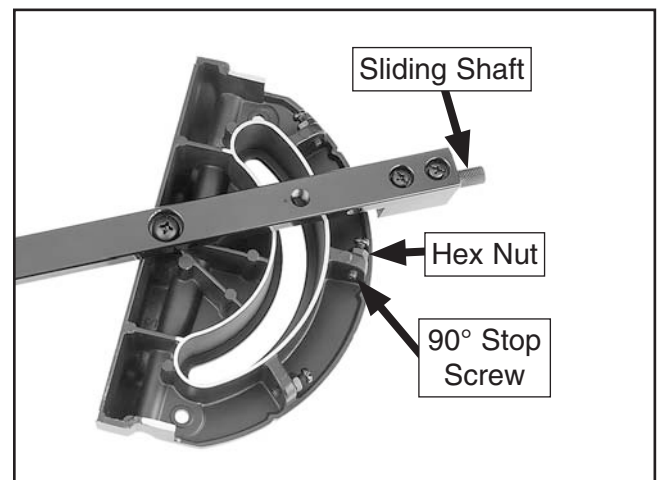

**Figure 118.** Checking 90° stop on miter gauge.

—If the square touches the miter body and the body of the blade (not the teeth) evenly at the same time, then it is square to the blade and the 90° stop is set correctly. No further adjustments are necessary.

—If the square does not touch the miter body and blade evenly at the same time, then proceed to **Step 4**.

5. Loosen the hex nut (jam nut) that secures the 90° stop screw (see **Figure 119**), and adjust the stop screw until it is seated against the shaft while the square is evenly touching the miter body and the blade body, then tighten the hex nut.



**Figure 119.** Checking 45° stop on miter gauge.

6. Loosen the screw on the front of the miter bar, adjust the pointer to 0°, then tighten the screw.

## Checking/Setting 45° Stops

Follow the same process with the 45° and 30° stops that you followed with the 90°, except using a 45° and 30° square or adjustable square to verify that the miter body is 45° to the blade, as shown in.





# Belt Tension & Replacement

The drive belt stretches slightly as the saw is used. Most of the belt stretching will happen during the first 16 hours of use, but it may continue through continued use. If you notice that the belt is slipping, it will need to be tensioned. If the belt is cracked, frayed, or shows other signs of excessive wear, it will need to be replaced.

Tools Needed	Qty
Hex Wrench 6mm.....	1

## Tensioning Belt

1. DISCONNECT SAW FROM POWER!
2. Raise the blade completely, then open the motor cabinet.
3. Loosen the cap screw on the motor shown in **Figure 120**, and pivot the motor up and down to make sure that it is movable.

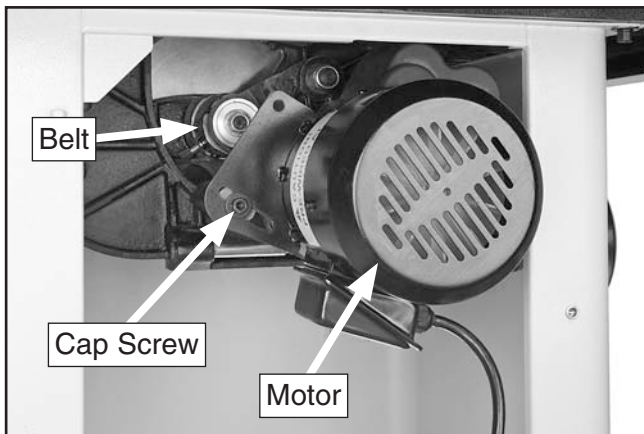

**Figure 120.** Motor mounting nut.

4. Press down on the motor with one hand to keep the belt tension tight and tighten the cap screw.
5. Press the belt in the center to check belt tension. The belt is correctly tensioned when there is approximately  $\frac{1}{4}$ " deflection when it is pushed with moderate pressure, as shown in **Figure 121**.

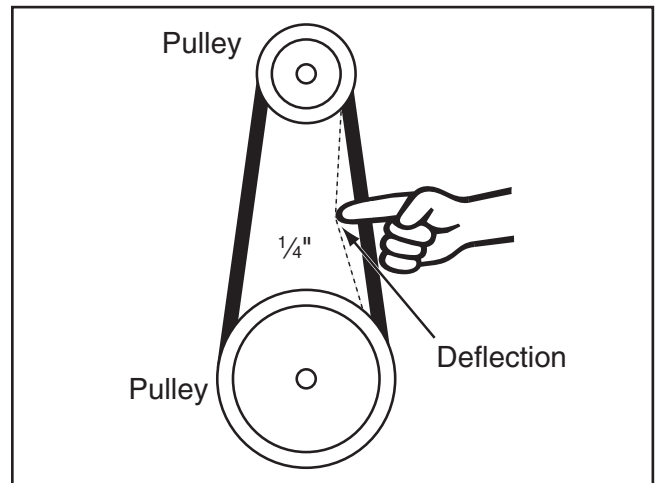

**Figure 121.** Checking belt tension.

—If there is more than  $\frac{1}{4}$ " deflection when the belt is pushed with moderate pressure, loosen the cap screw, push the motor downward, then tighten the cap screw.

6. Close the motor access cover.

## Replacing Belt

1. DISCONNECT SAW FROM POWER!
2. Lower the blade completely, then open the motor access cover.
3. Loosen the cap screw that secures the motor (see **Figure 120**) and lift the motor fully to remove tension on the belt. Tighten the cap screw to hold the motor in this position, then roll the belt off of the arbor and motor pulleys.
4. Install a new belt onto the pulleys, loosen the cap screw, then lower the motor. Use the blade elevation handwheel to raise the blade completely.
5. Press down on the motor with one hand to keep the belt tension tight and tighten the cap screw.
6. Follow **Step 5** in the **Tensioning Belt** subsection on this page to check V-belt tension.
7. Close the motor access cover.



# SECTION 9: WIRING

These pages are current at the time of printing. However, in the spirit of improvement, we may make changes to the electrical systems of future machines. Compare the manufacture date of your machine to the one stated in this manual, and study this section carefully.

If there are differences between your machine and what is shown in this section, call Technical Support at (570) 546-9663 for assistance BEFORE making any changes to the wiring on your machine. An updated wiring diagram may be available. **Note:** *Please gather the serial number and manufacture date of your machine before calling. This information can be found on the main machine label.*

## WARNING

### Wiring Safety Instructions

**SHOCK HAZARD.** Working on wiring that is connected to a power source is extremely dangerous. Touching electrified parts will result in personal injury including but not limited to severe burns, electrocution, or death. Disconnect the power from the machine before servicing electrical components!

**MODIFICATIONS.** Modifying the wiring beyond what is shown in the diagram may lead to unpredictable results, including serious injury or fire. This includes the installation of unapproved after-market parts.

**WIRE CONNECTIONS.** All connections must be tight to prevent wires from loosening during machine operation. Double-check all wires disconnected or connected during any wiring task to ensure tight connections.

**CIRCUIT REQUIREMENTS.** You MUST follow the requirements at the beginning of this manual when connecting your machine to a power source.

**WIRE/COMPONENT DAMAGE.** Damaged wires or components increase the risk of serious personal injury, fire, or machine damage. If you notice that any wires or components are damaged while performing a wiring task, replace those wires or components.

**MOTOR WIRING.** The motor wiring shown in these diagrams is current at the time of printing but may not match your machine. If you find this to be the case, use the wiring diagram inside the motor junction box.















**CAPACITORS/INVERTERS.** Some capacitors and power inverters store an electrical charge for up to 10 minutes after being disconnected from the power source. To reduce the risk of being shocked, wait at least this long before working on capacitors.

**EXPERIENCING DIFFICULTIES.** If you are experiencing difficulties understanding the information included in this section, contact our Technical Support at (570) 546-9663.

#### NOTICE

The photos and diagrams included in this section are best viewed in color. You can view these pages in color at [www.grizzly.com](http://www.grizzly.com).

#### COLOR KEY

BLACK		BLUE		YELLOW		LIGHT BLUE	
WHITE		BROWN		YELLOW GREEN		BLUE WHITE	
GREEN		GRAY		PURPLE		TURQUOISE	
RED		ORANGE		PINK			



# Wiring Diagram

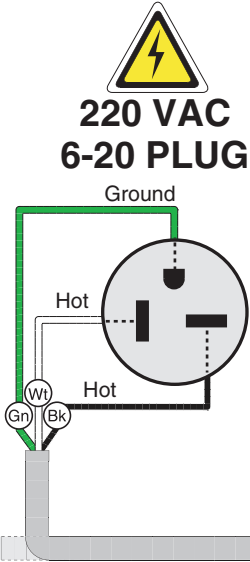
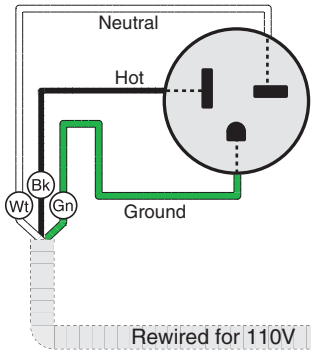

## SWITCH BOX

(See Figure 124)

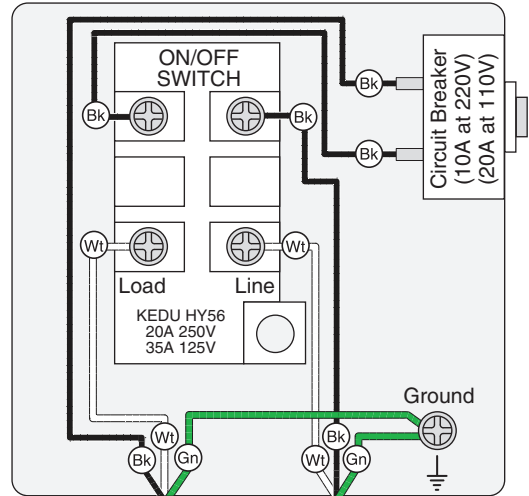

(See Figure 122)

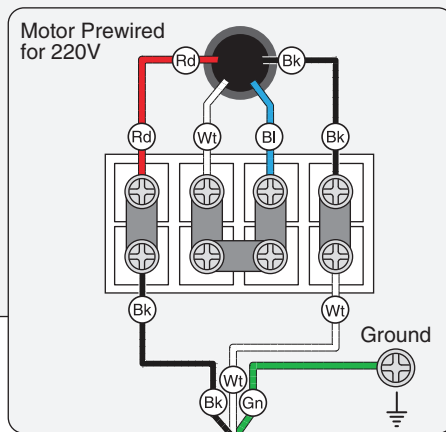
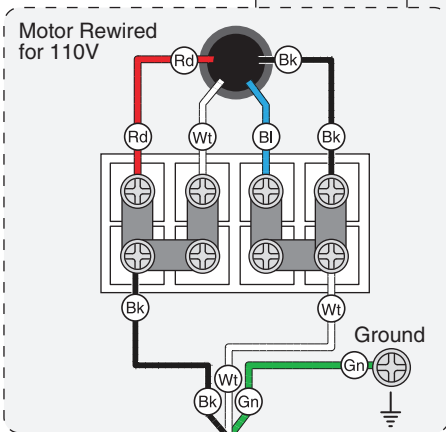
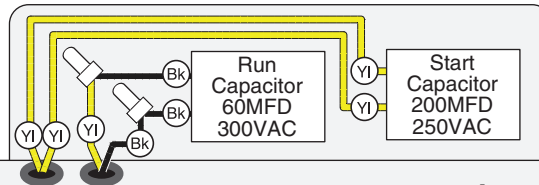

Rewired for 110V



# Electrical Components

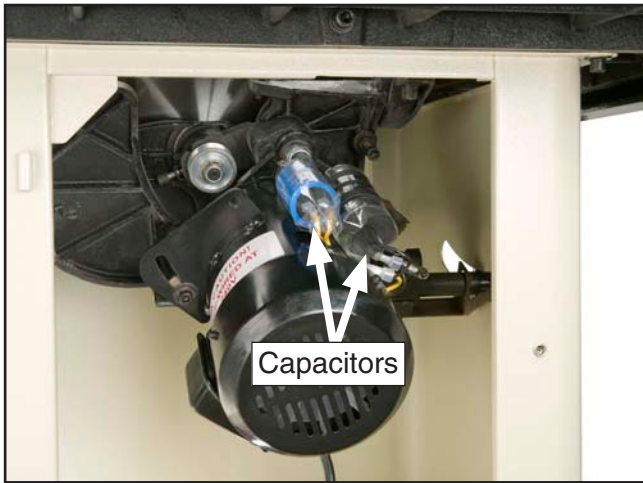

Figure 122. Motor capacitors.

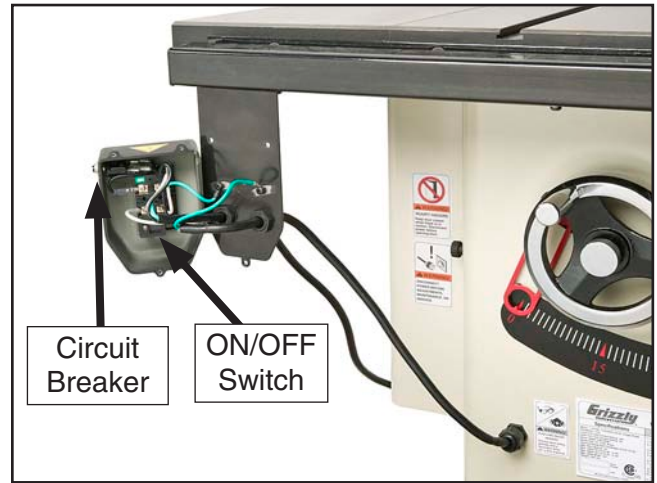

Figure 124. Switch box components.

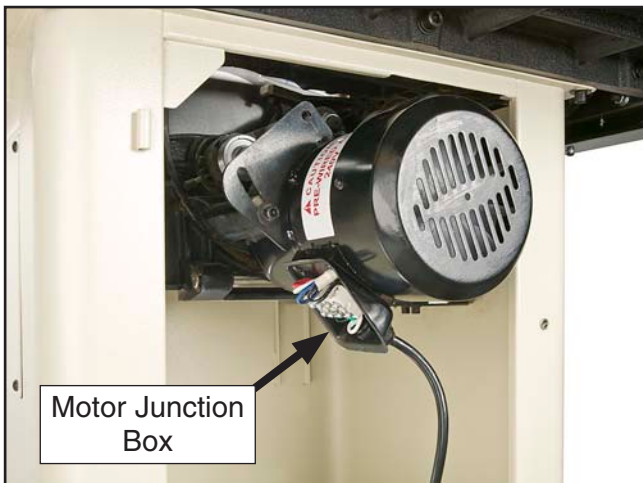
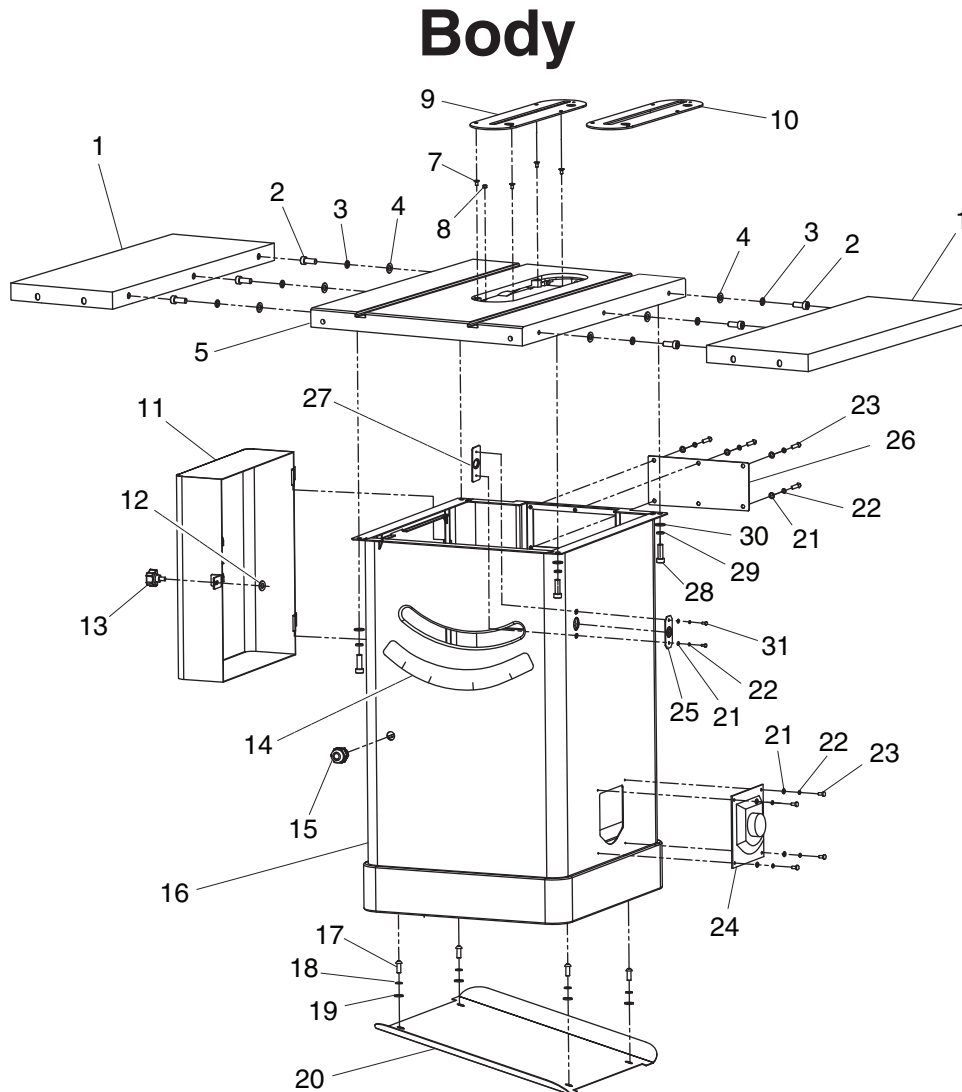

Figure 123. Motor junction box.



# SECTION 10: PARTS



REF	PART #	DESCRIPTION
1	P0715P001	EXTENSION WING
2	PCAP88M	CAP SCREW M10-1.25 X 25
3	PLW06M	LOCK WASHER 10MM
4	PW04M	FLAT WASHER 10MM
5	P0715P005	TABLE
7	PFH07M	FLAT HD SCR M5-.8 X 10
8	P0715P008	MAGNET
9	P0715P009	STANDARD TABLE INSERT
10	P0715P010	DADO TABLE INSERT
11	P0715P011	MOTOR COVER
12	PTLW13M	INT TOOTH WASHER 6MM
13	P0715P013	KNOB BOLT M6-1
14	P0715P014	TILT SCALE
15	P0715P015	STRAIN RELIEF
16	P0715P016	CABINET STAND

REF	PART #	DESCRIPTION
17	PS14M	PHLP HD SCR M6-1 X 12
18	PLW03M	LOCK WASHER 6MM
19	PWF06M	FENDER WASHER 6MM
20	P0715P020	BASE PLATE
21	PW02M	FLAT WASHER 5MM
22	PLW01M	LOCK WASHER 5MM
23	PCAP33M	CAP SCREW M5-.8 X 12
24	P0715P024	DUST HOOD 4"
25	P0715P025	LEADSCREW EXTERNAL BRACKET
26	P0715P026	CABINET REAR ACCESS PANEL
27	P0715P027	LEADSCREW INTERNAL BRACKET
28	PCAP31M	CAP SCREW M8-1.25 X 25
29	PLW04M	LOCK WASHER 8MM
30	PW01M	FLAT WASHER 8MM
31	PCAP15M	CAP SCREW M5-.8 X 20



# Trunnion

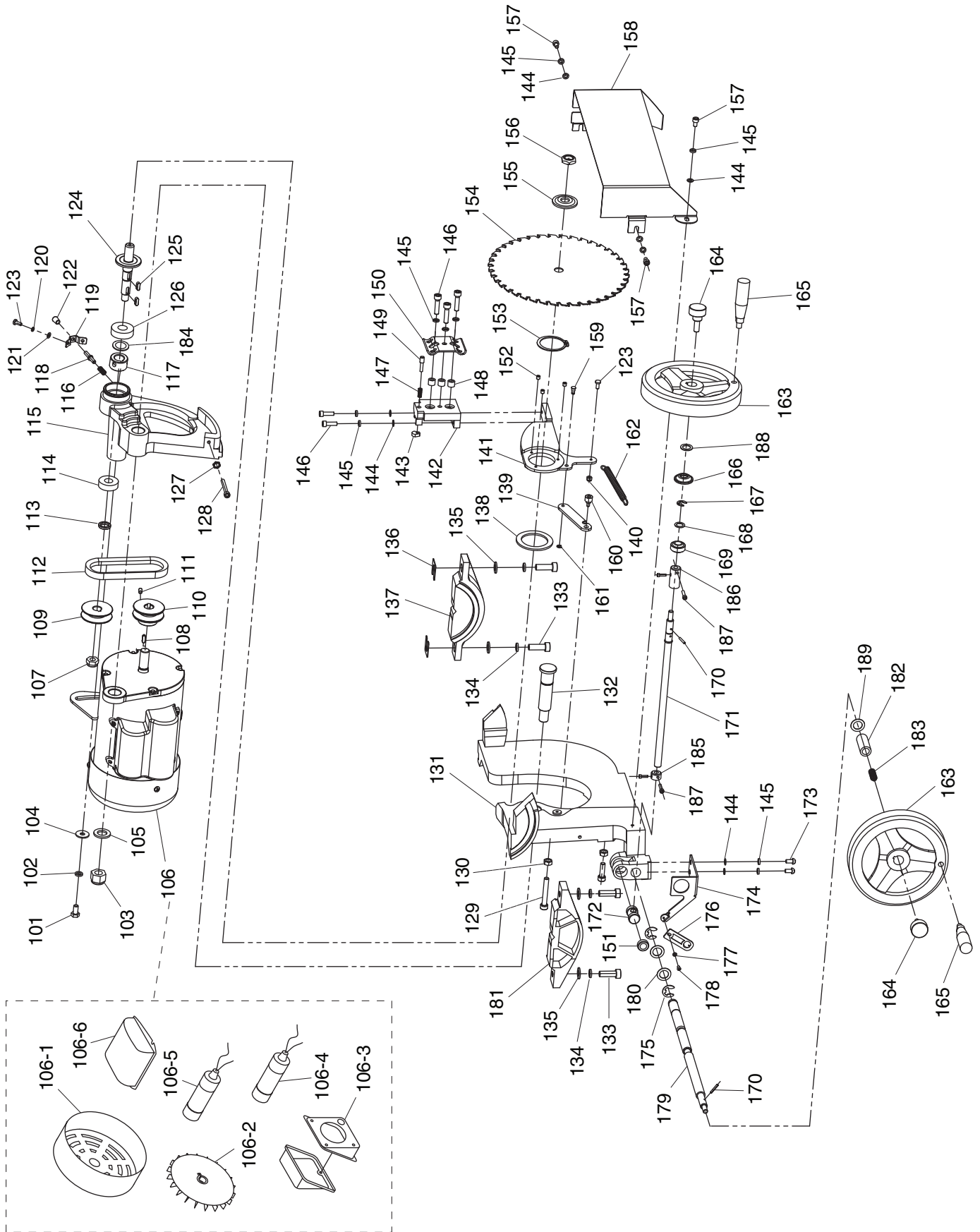

# Trunnion Parts List

REF	PART #	DESCRIPTION
101	PB03M	HEX BOLT M8-1.25 X 16
102	PLW04M	LOCK WASHER 8MM
103	PLN07M	LOCK NUT M16-2
104	PWF08M	FENDER WASHER 8MM
105	PW08M	FLAT WASHER 16MM
106	P0715P106	MOTOR 2HP 110/220V 1PH
106-1	P0715P106-1	MOTOR FAN COVER
106-2	P0715P106-2	MOTOR FAN
106-3	P0715P106-3	MOTOR JUNCTION BOX
106-4	P0715P106-4	R CAPACITOR 60M 300V 1-3/4 X 4
106-5	P0715P106-5	S CAP. 200M 250V 1-3/4 X 2-1/2
106-6	P0715P106-6	CAPACITOR COVER
107	PLN09M	LOCK NUT M12-1.75
108	PK07M	KEY 6 X 6 X 20
109	P0715P109	ARBOR PULLEY
110	P0715P110	MOTOR PULLEY
111	PSS01M	SET SCREW M6-1 X 10
112	P0715P112	RIBBED V-BELT 6PJ-365
113	P0715P113	ARBOR BUSHING
114	P6202-2RS	BALL BEARING 6202-2RS
115	P0715P115	MOTOR MOUNT
116	P0715P116	COMPRESSION SPRING
117	P0715P117	ARBOR LOCK BUSHING
118	P0715P118	ARBOR LOCK PIN
119	P0715P119	BEVEL STOP SUPPORT
120	PW02M	FLAT WASHER 5MM
121	PLW01M	LOCK WASHER 5MM
122	P0715P122	ARBOR LOCK PIN KNOB
123	PS08M	PHLP HD SCR M5-.8 X 12
124	P0715P124	ARBOR
125	PK20M	KEY 5 X 5 X 15
126	P6202-2RS	BALL BEARING 6202-2RS
127	PN01M	HEX NUT M6-1
128	PCAP29M	CAP SCREW M6-1 X 40
129	PCAP90M	CAP SCREW M10-1.5 X 55
130	PN02M	HEX NUT M10-1.5
131	P0715P131	MAIN TRUNNION
132	P0715P132	MOTOR MOUNT PIVOT SHAFT
133	PB177M	HEX BOLT M10-1.25 X 30
134	PLW06M	LOCK WASHER 10MM
135	PW04M	FLAT WASHER 10MM
136	P0715P136	TABLE SHIM
137	P0715P137	REAR TRUNNION
138	P0715P138	SPACER
139	P0715P139	SPRING BRACKET
140	PLN02M	LOCK NUT M5-.8
141	P0715P141	ARBOR SUPPORT
142	P0715P142	RIVING KNIFE MOUNT

REF	PART #	DESCRIPTION
143	P0715P143	LOCK PIN CAM
144	PW03M	FLAT WASHER 6MM
145	PLW03M	LOCK WASHER 6MM
146	PCAP02M	CAP SCREW M6-1 X 20
147	P0715P147	COMPRESSION SPRING
148	P0715P148	SPACER
149	P0715P149	LOCK PIN
150	P0715P150	RIVING KNIFE CLAMP PLATE
151	P0715P151	LOCK COLLAR
152	PSS26M	SET SCREW M5-.8 X 6
153	PR32M	EXT RETAINING RING 48MM
154	P0715P154	SAW BLADE 10" X 40T 5/8" ARBOR
155	P0715P155	ARBOR FLANGE
156	P0715P156	ARBOR NUT
157	PCAP04M	CAP SCREW M6-1 X 10
158	P0715P158	LOWER BLADE GUARD
159	P0715P159	GROOVED CAPTIVE PIN
160	P0715P160	SPRING RETAINING SCREW
161	PEC02M	E-CLIP 4MM
162	P0715P162	TENSION SPRING
163	P0715P163	HANDWHEEL
164	P0715P164	HANDWHEEL LOCK KNOB
165	P0715P165	HANDWHEEL HANDLE
166	P0715P166	BEVELED BUSHING
167	PEC10M	E-CLIP 9MM
168	P0715P168	SPACER
169	P0715P169	BEARING WASHER
170	PRP42M	ROLL PIN 3 X 20
171	P0715P171	TILT LEADSCREW
172	P0715P172	TILT LEADSCREW NUT
173	PS14M	PHLP HD SCR M6-1 X 12
174	P0715P174	POINTER BRACKET
175	PEC12M	E-CLIP 12MM
176	P0715P176	POINTER
177	PW05M	FLAT WASHER 4MM
178	PS07M	PHLP HD SCR M4-.7 X 8
179	P0715P179	ELEVATION SHAFT
180	P0715P180	SPACER
181	P0715P181	FRONT TRUNNION
182	P0715P182	ELEVATION SHAFT BUSHING
183	P0715P183	COMPRESSION SPRING
184	P0715P184	WAVE WASHER
185	P0715P185	LOCK COLLAR 90 DEG
186	P0715P186	LOCK COLLAR 45 DEG
187	PCAP24M	CAP SCREW M5-.8 X 16
188	P0715P188	TILT LEADSCREW SPACER
189	P0715P189	ELEVATION SHAFT SPACER



# Power Switch

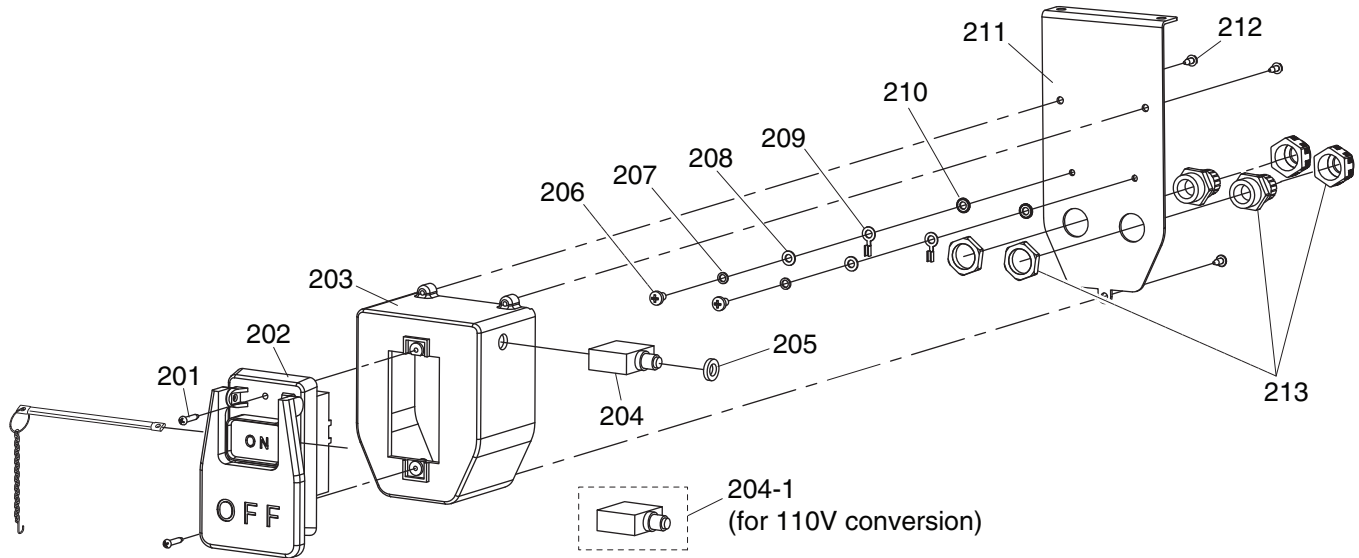

REF	PART #	DESCRIPTION
201	PHTEK44M	TAP SCREW M3.5 X 19
202	P0715P202	ON/OFF PADDLE SWITCH W/PIN
203	P0715P203	SWITCH BOX
204	P0715P204	CIRCUIT BREAKER 10A 220V
204-1	P0715P204-1	CIRCUIT BREAKER 20A 110V
205	P0715P205	CIRCUIT BREAKER NUT
206	PS05M	PHLP HD SCR M5-.8 X 8

REF	PART #	DESCRIPTION
207	PLW01M	LOCK WASHER 5MM
208	PW02M	FLAT WASHER 5MM
209	P0715P209	CLAMP-ON TERMINAL RING
210	PTLW02M	EXT TOOTH WASHER 5MM
211	P0715P211	SWITCH BRACKET
212	PHTEK18M	TAP SCREW M3.5 X 10
213	P0715P213	STRAIN RELIEF

# Miter Gauge

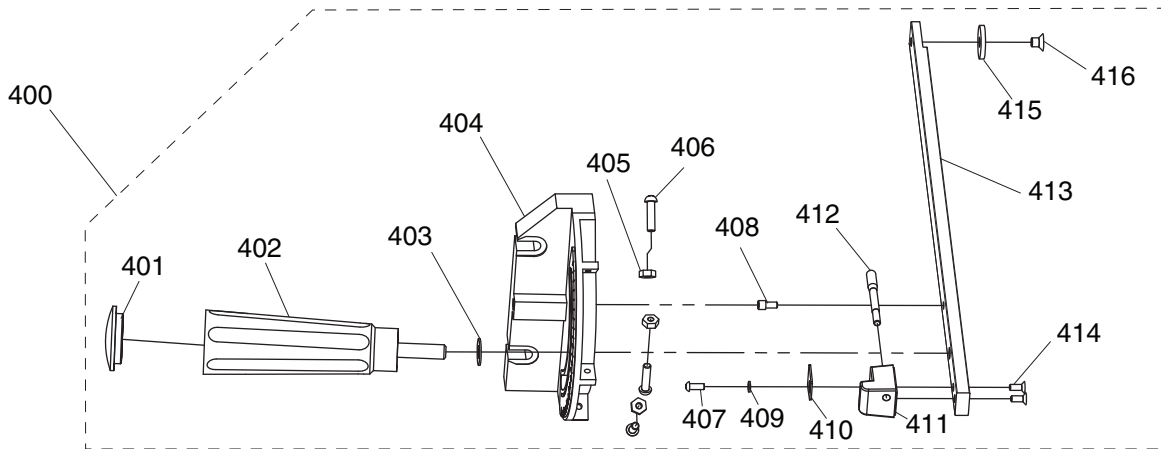

REF	PART #	DESCRIPTION
400	P0715P400	MITER GAUGE ASSEMBLY
401	P0715P401	HANDLE PLUG
402	P0715P402	HANDLE
403	P0715P403	SPACER
404	P0715P404	MITER GAUGE BODY
405	PN06M	HEX NUT M5-.8
406	PS06M	PHLP HD SCR M5-.8 X 20
407	PS38M	PHLP HD SCR M4-.7 X 10
408	P0715P408	PIVOT PIN

REF	PART #	DESCRIPTION
409	PW05M	FLAT WASHER 4MM
410	P0715P410	POINTER
411	P0715P411	STOP BLOCK
412	P0715P412	STOP PIN
413	P0715P413	MITER BAR
414	PFH19M	FLAT HD SCR M4-.7 X 10
415	P0715P415	T-SLOT WASHER
416	PFH04M	FLAT HD SCR M6-1 X 8





# Blade Guard

300V2

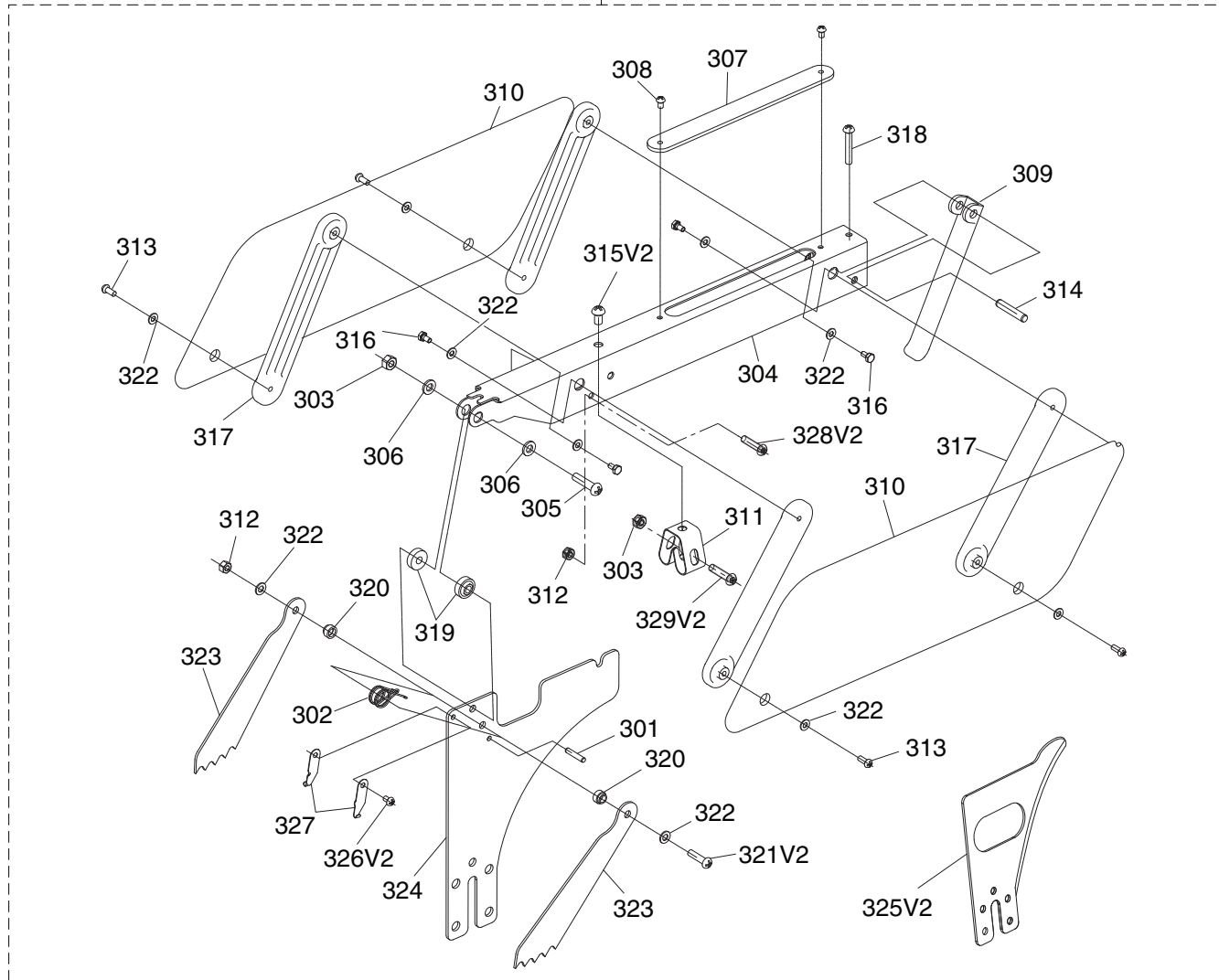

REF	PART #	DESCRIPTION
300V2	P0715P300V2	BLADE GUARD ASSEMBLY V2.11.10
301	PRP39M	ROLL PIN 4 X 20
302	P0690319	TORSION SPRING
303	PLN03M	LOCK NUT M6-1
304	P0690322V2	SUPPORTING ARM
305	PS47M	PHLP HD SCR M6-1 X 25
306	PW03M	FLAT WASHER 6MM
307	P0690326	TOP GUARD
308	PS17M	PHLP HD SCR M4-.7 X 6
309	P0690328	FRONT GUARD PLASTIC
310	P0690331V2	SIDE GUARD PLASTIC
311	P0690356	GUARD CLAMP
312	PLN02M	LOCK NUT M5-.8
313	PS38M	PHLP HD SCR M4-.7 X 10
314	PRP107M	ROLL PIN 6 X 32

REF	PART #	DESCRIPTION
315V2	P0690354V2	RIVET 5 X 12MM V2.11.10
316	PB122M	HEX BOLT M4-.7 X 8
317	P0690332V2	GUARD SUPPORT
318	PS62M	PHLP HD SCR M6-1 X 30
319	P0690342V2	SUPPORT ARM SPACER
320	P0690345	PAWL SPACER
321V2	PB42M	HEX BOLT M5-.8 X 20
322	PW02M	FLAT WASHER 5MM
323	P0690349	PAWL
324	P0690350	SPLITTER
325V2	P0715P325V2	RIVING KNIFE V2.04.11
326V2	P0690352V2	RIVET V2.11.10
327	P0690353	RIVING KNIFE HOOK PLATE
328V2	PB11M	HEX BOLT M5-.8 X 8
329V2	PS31M	PHLP HD SCR M6-1 X 35



# Fence

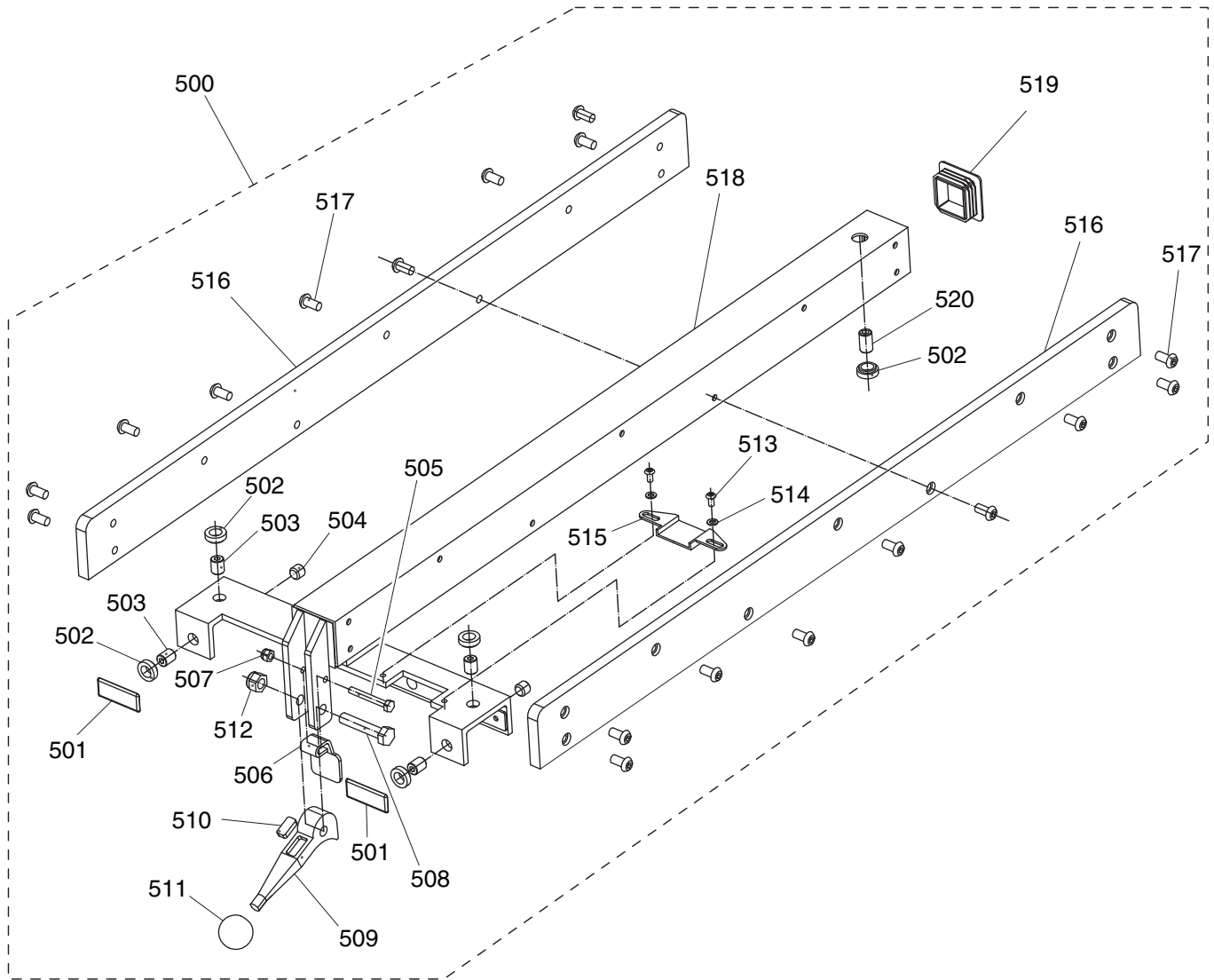

REF	PART #	DESCRIPTION
500	P0715P500	RIP FENCE ASSEMBLY
501	P0715P501	GLIDE PAD
502	P0715P502	ROUND LOCK NUT M12-1.75
503	PSS109M	SET SCREW M12-1.75 X 16
504	PSS108M	SET SCREW M12-1.75 X 10
505	PB47M	HEX BOLT M6-1 X 40
506	P0715P506	LOCK FOOT
507	PLN03M	LOCK NUT M6-1
508	PB22M	HEX BOLT M8-1.25 X 50
509	P0715P509	FENCE LOCK LEVER
510	P0715P510	MAGNET

REF	PART #	DESCRIPTION
511	P0715P511	BALL KNOB
512	PLN10M	LOCK NUT M10-1.25
513	PS22M	PHLP HD SCR M5-.8 X 25
514	PLW01M	LOCK WASHER 5MM
515	P0715P515	FENCE SCALE WINDOW
516	P0715P516	FENCE FACE
517	PS11M	PHLP HD SCR M6-1 X 16
518	P0715P518	FENCE BASE
519	P0715P519	FENCE BASE END CAP 50 X 50MM
520	PSS32M	SET SCREW M12-1.75 X 30



# Rails

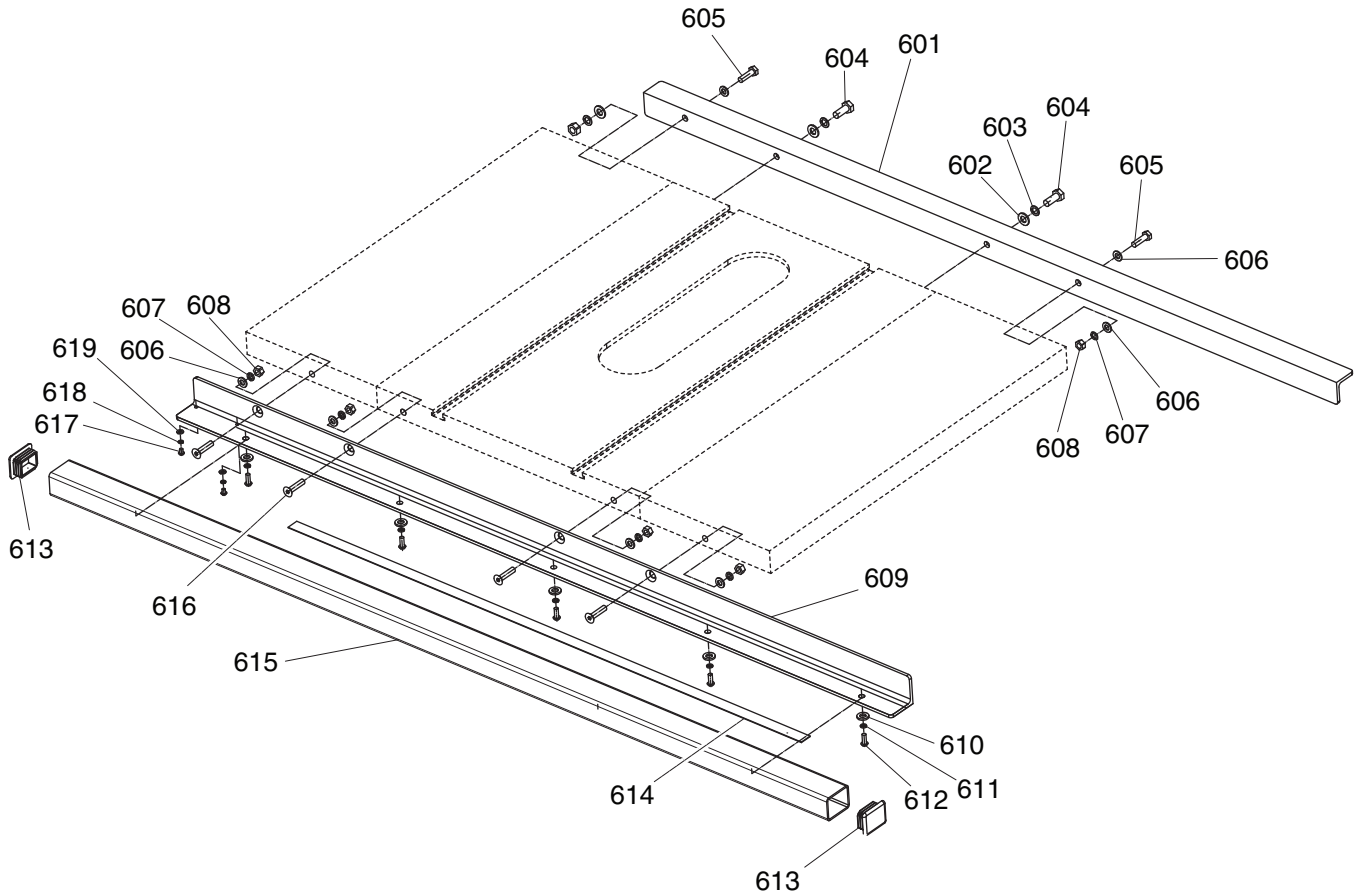

REF	PART #	DESCRIPTION
601	P0715P601	REAR RAIL
602	PW04M	FLAT WASHER 10MM
603	PLW06M	LOCK WASHER 10MM
604	PCAP64M	CAP SCREW M10-1.5 X 25
605	PCAP40M	CAP SCREW M8-1.25 X 35
606	PW01M	FLAT WASHER 8MM
607	PLW04M	LOCK WASHER 8MM
608	PN03M	HEX NUT M8-1.25
609	P0715P609	FRONT RAIL
610	PW03M	FLAT WASHER 6MM

REF	PART #	DESCRIPTION
611	PLW03M	LOCK WASHER 6MM
612	PCAP01M	CAP SCREW M6-1 X 16
613	P0715P613	GUIDE TUBE END CAP 40 X 50MM
614	P0715P614	FENCE SCALE
615	P0715P615	FENCE GUIDE TUBE
616	PFH36M	FLAT HD SCR M8-1.25 X 35
617	PCAP33M	CAP SCREW M5-.8 X 12
618	PW02M	FLAT WASHER 5MM
619	PLW01M	LOCK WASHER 5MM



# Machine Labels

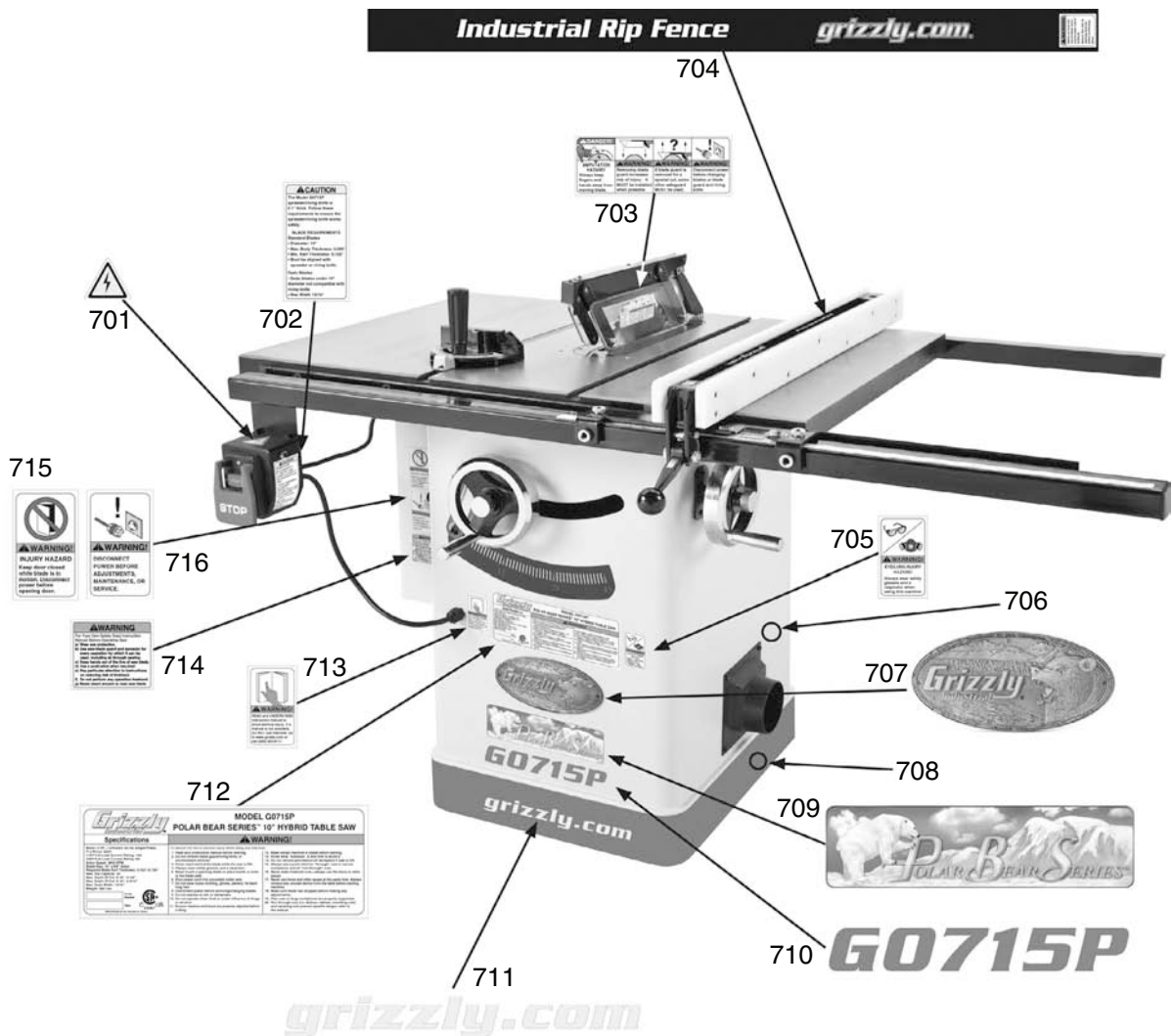

REF	PART #	DESCRIPTION
701	PLABEL-14A	ELECTRICITY LABEL
702	P0715P702	RIVING KNIFE PRECAUTIONS LABEL
703	PLABEL-76	BLADE GUARD LABEL
704	P0715P704	RIP FENCE LABEL
705	PLABEL-57	EYE/LUNG HAZARD LABEL
706	PPAINT-24	PB WHITE TOUCH-UP PAINT
707	G8588	GRIZZLY NAMEPLATE
708	P0715P708	GRIZZLY GREEN TAPE

REF	PART #	DESCRIPTION
709	PLABEL-75	POLAR BEAR LOGO LABEL
710	P0715P710	MODEL NUMBER LABEL
711	PLABEL-77	GRIZZLY.COM PB LABEL
712	P0715P712	MACHINE ID LABEL
713	PLABEL-12A	READ MANUAL LABEL
714	PLABEL-78	TABLE SAW WARNING LABEL
715	PLABEL-79A	MOTOR DOOR WARNING LABEL
716	PLABEL-63	DISCONNECT POWER LABEL

## CAUTION

Safety labels warn about machine hazards and ways to prevent injury. The owner of this machine **MUST** maintain the original location and readability of the labels on the machine. If any label is removed or becomes unreadable, **REPLACE** that label before using the machine again. Contact Grizzly at (800) 523-4777 or [www.grizzly.com](http://www.grizzly.com) to order new labels.





# WARRANTY CARD

Name \_\_\_\_\_  
 Street \_\_\_\_\_  
 City \_\_\_\_\_ State \_\_\_\_\_ Zip \_\_\_\_\_  
 Phone # \_\_\_\_\_ Email \_\_\_\_\_ Invoice # \_\_\_\_\_  
 Model # \_\_\_\_\_ Order # \_\_\_\_\_ Serial # \_\_\_\_\_

The following information is given on a voluntary basis. It will be used for marketing purposes to help us develop better products and services. **Of course, all information is strictly confidential.**

1. How did you learn about us?

Advertisement                       Friend                       Catalog  
 Card Deck                               Website                       Other:

2. Which of the following magazines do you subscribe to?

<input type="checkbox"/> Cabinetmaker & FDM	<input type="checkbox"/> Popular Science	<input type="checkbox"/> Wooden Boat
<input type="checkbox"/> Family Handyman	<input type="checkbox"/> Popular Woodworking	<input type="checkbox"/> Woodshop News
<input type="checkbox"/> Hand Loader	<input type="checkbox"/> Precision Shooter	<input type="checkbox"/> Woodsmith
<input type="checkbox"/> Handy	<input type="checkbox"/> Projects in Metal	<input type="checkbox"/> Woodwork
<input type="checkbox"/> Home Shop Machinist	<input type="checkbox"/> RC Modeler	<input type="checkbox"/> Woodworker West
<input type="checkbox"/> Journal of Light Cont.	<input type="checkbox"/> Rifle	<input type="checkbox"/> Woodworker's Journal
<input type="checkbox"/> Live Steam	<input type="checkbox"/> Shop Notes	<input type="checkbox"/> Other:
<input type="checkbox"/> Model Airplane News	<input type="checkbox"/> Shotgun News	
<input type="checkbox"/> Old House Journal	<input type="checkbox"/> Today's Homeowner	
<input type="checkbox"/> Popular Mechanics	<input type="checkbox"/> Wood	

3. What is your annual household income?

\$20,000-\$29,000                       \$30,000-\$39,000                       \$40,000-\$49,000  
 \$50,000-\$59,000                       \$60,000-\$69,000                       \$70,000+

4. What is your age group?

20-29                                       30-39                                       40-49  
 50-59                                       60-69                                       70+

5. How long have you been a woodworker/metalworker?

0-2 Years                       2-8 Years                       8-20 Years                       20+ Years

6. How many of your machines or tools are Grizzly?

0-2                       3-5                       6-9                       10+

7. Do you think your machine represents a good value?       Yes                       No

8. Would you recommend Grizzly Industrial to a friend?       Yes                       No

9. Would you allow us to use your name as a reference for Grizzly customers in your area?

**Note:** We never use names more than 3 times.       Yes                       No

10. Comments: \_\_\_\_\_  
 \_\_\_\_\_  
 \_\_\_\_\_  
 \_\_\_\_\_

CUT ALONG DOTTED LINE

FOLD ALONG DOTTED LINE

\_\_\_\_\_  
\_\_\_\_\_  
\_\_\_\_\_



Place  
Stamp  
Here



**GRIZZLY INDUSTRIAL, INC.**  
**P.O. BOX 2069**  
**BELLINGHAM, WA 98227-2069**



FOLD ALONG DOTTED LINE

Send a Grizzly Catalog to a friend:

Name \_\_\_\_\_  
Street \_\_\_\_\_  
City \_\_\_\_\_ State \_\_\_\_\_ Zip \_\_\_\_\_

TAPE ALONG EDGES--PLEASE DO NOT STAPLE

# WARRANTY AND RETURNS

---

Grizzly Industrial, Inc. warrants every product it sells for a period of **1 year** to the original purchaser from the date of purchase. This warranty does not apply to defects due directly or indirectly to misuse, abuse, negligence, accidents, repairs or alterations or lack of maintenance. This is Grizzly's sole written warranty and any and all warranties that may be implied by law, including any merchantability or fitness, for any particular purpose, are hereby limited to the duration of this written warranty. We do not warrant or represent that the merchandise complies with the provisions of any law or acts unless the manufacturer so warrants. In no event shall Grizzly's liability under this warranty exceed the purchase price paid for the product and any legal actions brought against Grizzly shall be tried in the State of Washington, County of Whatcom.

We shall in no event be liable for death, injuries to persons or property or for incidental, contingent, special, or consequential damages arising from the use of our products.

To take advantage of this warranty, contact us by mail or phone and give us all the details. We will then issue you a "Return Number," which must be clearly posted on the outside as well as the inside of the carton. We will not accept any item back without this number. Proof of purchase must accompany the merchandise.

The manufacturers reserve the right to change specifications at any time because they constantly strive to achieve better quality equipment. We make every effort to ensure that our products meet high quality and durability standards and we hope you never need to use this warranty.

Please feel free to write or call us if you have any questions about the machine or the manual.

Thank you again for your business and continued support. We hope to serve you again soon.

# *grizzly.com*<sup>®</sup>

**TOOL WEBSITE**

Buy Direct and Save with Grizzly<sup>®</sup> – Trusted, Proven and a Great Value!  
~Since 1983~

*Visit Our Website Today For  
Current Specials!*

**ORDER  
24 HOURS A DAY!  
1-800-523-4777**

