

deVention

QR X350 **Premium**

Match with **DEVO F12E Radio**

Quick Start Guide and Systems Flowchart

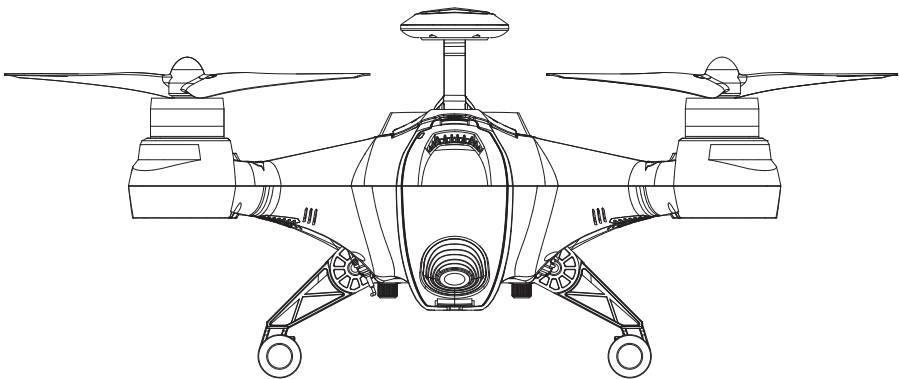

1.0 Preparation before flying

1.1 Get to know your aircraft

- Adopting Modular Design, easy to install and connect.
- A new generation flight control system built-in, promote stable flight performance.
- Adopting indicator light on GPS, Compass, barometer and other parts, observation more intuitive.

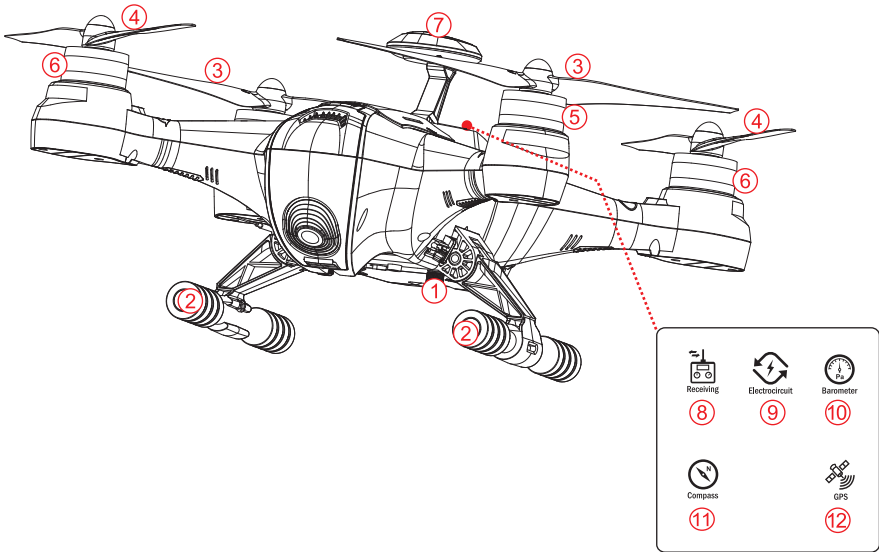

Indicator keep brighting means work properly.



- | | |
|--|-----------------------------------|
| 1. M3x18 Screw | 7. GPS module |
| 2. Skid landing | 8. Receiving detecting light |
| 3. Clockwise propeller (white cap) | 9. Electrocircuit detecting light |
| 4. Counterclockwise propeller(black cap) | 10. Barometer detecting light |
| 5. Motor (levogyrate thread is counterclockwise) | 11. Compass detecting light |
| 6. Motor (dextrogyrate thread is clockwise) | 12. GPS detecting light |

***The USB and UART ports are only purpose to upgrade software and debug by the manufacture.**

1.2 Get to know your DEVO F12E Radio (White version)

It's convenient to receive aerial photos, and equipped with swithes for Auto takeoff, one key Return to home, control video recording functions, easy to operate.

Mode 2 (Throttle stick on the left)	Left stick	THRO/RUDD stick
	Right stick	ELEV/AILE stick
	Left trim	THRO trim
	Right trim	ELEV trim
Mode 1 (Throttle stick on the right)	Left stick	ELEV/RUDD stick
	Right stick	THRO/AILE stick
	Left trim	ELEV trim
	Right trim	THRO trim

(0) Manual Mode	(1) GPS-hold Mode	(2) Return TO Home
		
Switch to "0"	Switch to "1"	Switch to "2"

- 1. 2.4G TX antenna
- 2. One Key to Start - AUTO Takeoff switch
- 3. Retractable Skid Landing - Landing Gear Retract Switch and Deploy landing gear
- 4. IOC - IOC control switch
Intelligent Orientation Control
- 5. Gimbal Roll - Gimbal ROLL control
- 6. Left trim
- 7. Left stick
- 8. RUDD trim
- 9. UP key
- 10. DN key
- 11. EXT key
- 12. ORBIT - Round flight mode
- 13. 0 Manual; 1 GPS;
2 Return Home(Control Mode Switch)
- 14. Start/Stop Video Rec-Camera Start/Stop
- 15. Gimbal Tilt - Gimbal TILT control
- 16. Right stick
- 17. Right trim
- 18. AILE trim
- 19. R key
- 20. L key
- 21. ENT key
- 22. Power switch

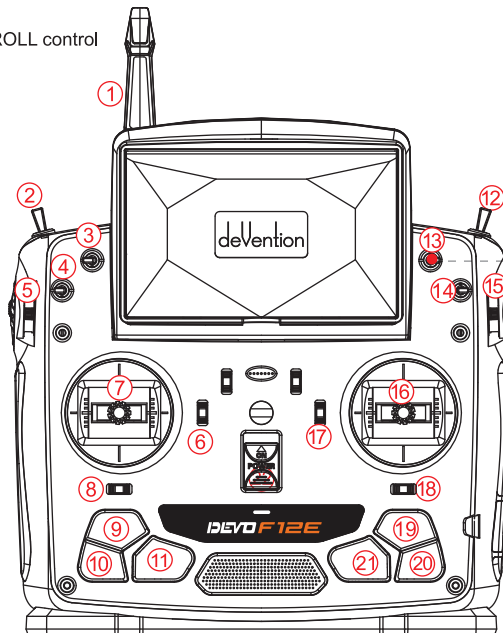

*Please refer to DEVO F12E manual

1.3 Assemble the QR X350 Premium

- ① Turn down the skid landing, and fix it tightly with screws.
- ② Install the clockwise propeller (white cap) to the clockwise motor (levogyrate thread is counterclockwise); install the counterclockwise propeller (black cap) to the counterclockwise motor (dextrogyrate thread is clockwise).

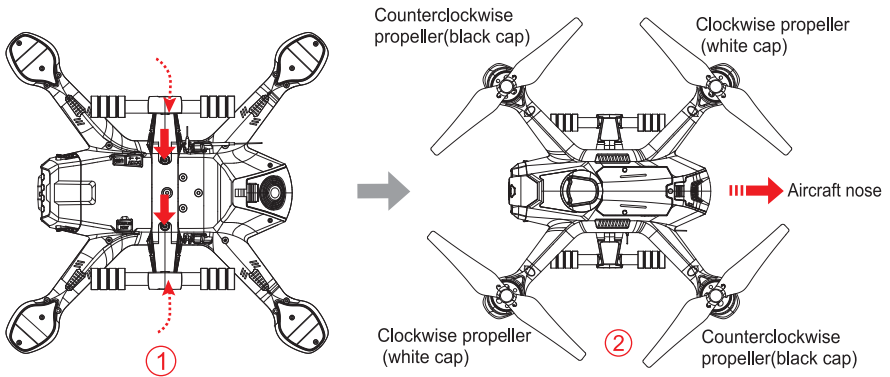

1.4 Learn how to fly safely

- (1) This product is suitable for people who has flight experience of model plane and older than 14-year-old.
 - (2) Do not fly in bad weather, such as windy, snowy, foggy weather, etc..
 - (3) Select the open, no-tall-buildings area. Extensive use of steel buildings will affect the compass work, blocking the GPS signal, causing worse on the aircraft positioning effect or even not able to locate.
 - (4) Please away from high-speed revolution parts(such as propellers and motors) during flight.
 - (5) When flying, PLZ keep the drone in sight control, away from obstacles, people, water and so on.
 - (6) Do not fly it in where there is high-voltage lines, communication base stations or towers, in order to avoid interference by the remote control.
 - (7) Please don't drive it in no-fly zone.
 - (8) Flight performance will be effected with environment when you drive it with altitude of 4500 meters, as the battery and gravity system will be influenced.
-

1.5 Specifications

● Aircraft specifications

Main Rotor Dia.: 233mm

Overall (L x W x H): 303 x 303 x 176mm

Weight: 1650g (Battery included)

Transmitter: DEVO F12E (White Version)

Receiver: BTR-2401(FCC) / BTR-2402(CE)

Brushless Motor: WK-WS-34-002A

Brushless ESC: QR X350 Premium(R/B)

Main Controller: QR X350 Premium

Battery: 29.6V 3000mAh 10C(8S) LiPo

Flight Time: Approximately 25 minutes

Working environment: -10 C ~ +40 C

2.0 Ready for flight

Place the aircraft on a flat surface, in an open space, with the back facing you.

2.1 Binding of the aircraft

- ① Put the smart aircraft battery into the aircraft.
- ② Put all the function switches to the 0 position, put all trims/knobs to the Middle position, move the throttle to the lowest position, then turn on the radio.
- ③ Turn the power switch to "ON", then press the power button for 3-5 seconds until the green power indicator lights up.
- ④ Within approx. 40 sec. the red LED light will stop flashing indicating that the code binding has finished.

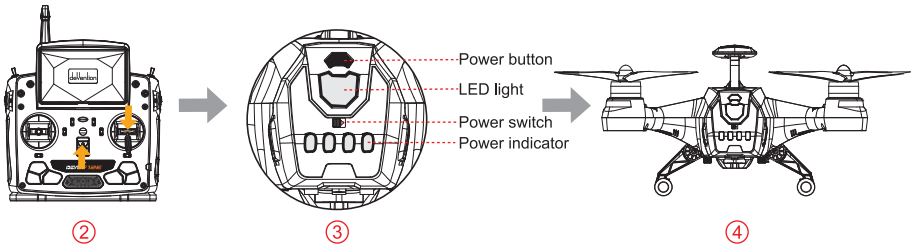

2.2 Compass Calibration

IMPORTANT: Make sure all TRIMS are in the center position, the trim value should be "0", and the motors are locked. The aircraft should NOT be flashing RED. By default, the motors will automatically be locked after the ID binding process. For more details about locking and unlocking motors, see points (2.4).

- ① Enter the calibration mode Do this by moving both sticks DOWN and to the middle position at the same time. The aircraft will start a blinking fast RED.
- ② FORWARD rotation. Smoothly rotate the aircraft forward in 90 degree increments, pausing for 1 second every 90 deg. (0 / 90 / 180 / 270 / 360)
- ③ CLOCKWISE rotation. Rotate the aircraft around the roll axis smoothly in 90 deg increments. Pausing 1 second for each 90 deg. (0 / 90 / 180 / 270 / 360)
- ④ HORIZONTAL rotation. Rotate the aircraft around the YAW axis smoothly in 90 deg increments. Pausing 1 second for each 90 deg. (0 / 90 / 180 / 270 / 360)
- ⑤ NOSE DOWN rotation. Rotate the aircraft facing the nose down. rotate smoothly in 90 deg increments. Pausing 1 second for each 90 deg. (0 / 90 / 180 / 270 / 360)
- ⑥ Place the aircraft in normal position. The rapid RED blinking will stop. This indicates that the calibration is finished. Disconnect the battery to save the settings.

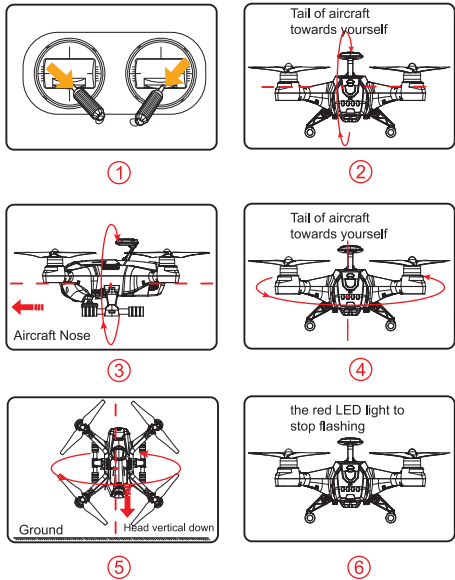

2.3 GPS indicator lights

GPS Satellites	<6	6	7	8	9	10	11	12	13
The blue LED status	No blinking	Blinking once	Blinking 2 times	Blinking 3 times	Blinking 4 times	Blinking 5 times	Blinking 6 times	Blinking 7 times	Blinking 8 times

IMPORTANT: For SAFE flight in GPS flight mode:

The BLUE indicator light should at least “double” blink, (two blinks at a time).

It is highly recommended that you wait for “triple blink” 8 statelites before starting the flight.

NEVER attempt to AUTO-START with less than “triple blinks”

2.4 Motor Unlock / Lock

● Motor Unlock

After binding the DEVO F12E to the QR X350 Premium, Check that all trims are neutral, the throttle stick is ALL the way Down with the display indicating 0% throttle. Check that ALL switches are in the UP position.

Note: that you can start the motors in the Manual Mode or the GPS-HOLD MODE.

Gently push the throttle stick down and move the rudder (YAW) stick to the left side.

(on mode2 radios throttle and rudder is the same stick)

You will see the RED indicator LED turn on, indicating that motors are unlocked.

Be very careful at this point, as pushing the thottle up will start the motors. You can test by pushing the stick up a little, the motors should start. For your safety, the motors will dis-arm again after 10seconds.

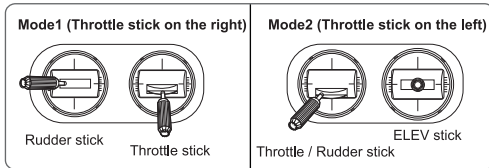

● Motor Lock

Lock the motors by moving the throttle stick all the way down and the rudder (YAW) stick all the way to the right. The RED LED light will go out when the motors are disarmed.

TEST: push the throttle stick up a little, the motors will not start when locked.

NOTICE:







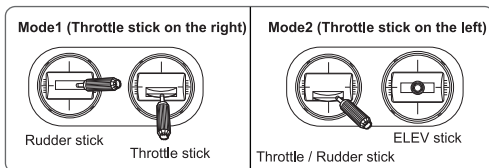



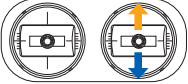
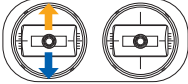

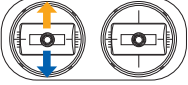

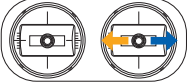
* The motors are LOCKED by default after successful binding.

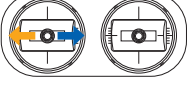
* Motors can be unlocked or locked in GPS-hold mode.

if you land in GPS mode, move the “0 Manual; 1 GPS; 2 Return Home” switch to position “0” or position “1” before locking the motors, make sure you wait until the QR X350 Premium is safely on the ground before changing the switch to “0” (manual) while changing, make sure to keep the throttle DOWN to prevent motors start.

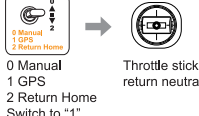
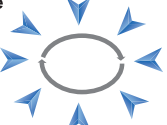

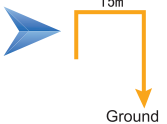
2.5 Operation Instruction

Model (← is the nose direction)	Mode1 (Throttle stick on the right)	Mode2 (Throttle stick on the left)
THROTTLE Up/down 		
PITCH Forward/backward 		
ROLL (lean) Left / right 		
YAW (turn) Left / right 		
AUTO TakeOff You should have triple blink = 8sats for this feature. 		
GPS hold mode In this mode, maneuver by moving the controls, and simply let go of the controls and the QR X350 Premium will hold its position. NOTE: You must CENTER the throttle stick for altitude hold 		DO NOT switch to manual before landing. It is safer to land in GPS hold mode, then switch to manual AFTER landing to lock motors
ROUND FLY mode This mode is used for making circles around an object of interest. RADIUS is set in the F12E menu by adjusting Position 2 value for AUX3 		
RETURN TO HOME Activating this feature will cause the QR X350 Premium to climb to 15m and fly to the starting location and proceed to land. 		

2.6 DEVO F12E Radio function setup and operation instructions

Function	Switch	Instructions
AUTO TakeOff	One Key to Start	<p>Place aircraft on level ground → Unlock Motors → Move throttle stick to lowest position</p> <p style="margin-left: 200px;">↓</p> <p style="margin-left: 200px;">0 Manual 1 GPS 2 Return Home switch to "1" position</p> <p style="margin-left: 100px;">← One Key to Start switch to "1" position</p> <p>IMPORTANT: ONLY use this function with BLUE TRIPLE blink = 8 or more satellites, AUTO takeoff with less satellites may result in a crash. AFTER completing auto-take-off, you can take control by moving the throttle stick to 50%, then flip the One Key to Start switch to "0" position.</p>
GPS hold mode	0 Manual 1 GPS 2 Return Home	<p>"0" position: Manual mode "1" position: GPS hold mode "2" position: Return To Home</p> <p>0 Manual 1 GPS 2 Return Home switch to "1" position → Throttle stick return neutral</p> <p>NEVER use this mode with less than 8 satellites locked, you should see BLUE TRIPLE BLINK. Before switching mode, always put the throttle stick to middle position (50%). IF the GPS signal degrades, the QR X350 Premium will automatically enter "Altitude hold mode" note in this mode it will drift, but will hold its altitude. After flying 50% of the battery, do NOT switch from GPS mode to Manual, this may cause a sudden drop / crash. You can land in GPS mode, after landing, keep the throttle stick DOWN and switch to manual, then lock the motors.</p>
Round Fly Mode	ORBIT	<p>"0" Position: OFF "1" Position: Not in use "2" Position: activate Round Fly</p> <p>This mode require 8 satellites locked, you should see BLUE TRIPLE BLINK. Before activating the round-fly mode, you should be in "GPS hold mode" always put the throttle stick to middle position (50%) The default roundfly radius is 5 meters (15 feet), You can change the Round Fly radius by editing the AUX 3 EPA (End Point Adjustment) on the F12E transmitter, for details on editing EPA settings, see the F12E instruction manual. After having changed the setting, you should turn ORBIT switch to "0" position to save the data, then return to "2" position to read the new Round Fly radius.</p>
Return TO Home	0 Manual 1 GPS 2 Return Home	<p>"0" position: Manual mode "1" position: GPS hold mode "2" position: Return To Home</p> <p>Throttle stick return neutral → 0 Manual; 1 GPS; 2 Return Home switch to "2" position</p> <p>The Return To Home mode, will only work when you have a solid GPS lock, it is recommend that you avoid flying if GPS lock is missing. After engaging Return to Home mode, leave the throttle stick at 50% (centered) DO NOT touch any switches on the F12E radio. To REGAIN control of the QR X350 Premium, make sure the throttle is centered, then flip the "0 Manual/1 GPS/2 Return Home" switch to position "1". In an emergency such as losing the control link between the F12E and the QR X350 Premium, the Failsafe system will automatically start RTH. You may not be able to interrupt an emergency RTH, simply let the aircraft continue until it lands.</p>

Function	Switch	Instructions
Hyper IOC Mode	IOC	<div style="display: flex; align-items: flex-start;">  <div> <p>IOC or Intelligent Orientation Control mode means that the aircraft's flight direction is only relative to the original take-off point (where you armed the motors). REGARDLESS of the actual aircraft heading, in this mode you can fly past something and pan the aircraft to frame your shot, without having to worry what direction the aircraft is facing.</p> <p>IOC switch "0" position: IOC OFF "1" position: IOC ON</p> <p>The IOC mode requires a strong GPS lock, you should have triple blinks on the right green GPS indicator light. IOC is inactive if the QR X350 Premium is less than 10 meter (30 feet) from the original take-off position. (point where you armed the motors)</p> <p>Fly the QR X350 Premium manually beyond 10 meters using the GPS mode, then activate the IOC mode, the QR X350 Premium will now fly IOC until you change the mode, you can pan freely for video shots, when you push the stick right or left, the QR X350 Premium will move sideways relative to the original take-off position. Pushing the pitch stick up will push the QR X350 Premium away from you, pulling the stick back brings the QR X350 Premium back to the starting point.</p> <p>When flying in IOC mode, you can make the QR X350 Premium return to the starting point simply by pulling the stick toward you.</p> <p>WARNING: The IOC turns off when the aircraft gets closer than 10meters to the take off point. Be prepared for this, as the system will switch back to GPS hold mode at that point. This switch can cause confusion if the pilot are not prepared.</p> </div> </div>

3.0 End flight

- ① Manual landing or back home function landing.
- ② First, power off aircraft battery, then power off radio battery.
- ③ Take the battery out of aircraft.

4.0 Additional remark

4.1 DEVO F12E Radio Setting(White version)

● Boot Screen(Main interface)

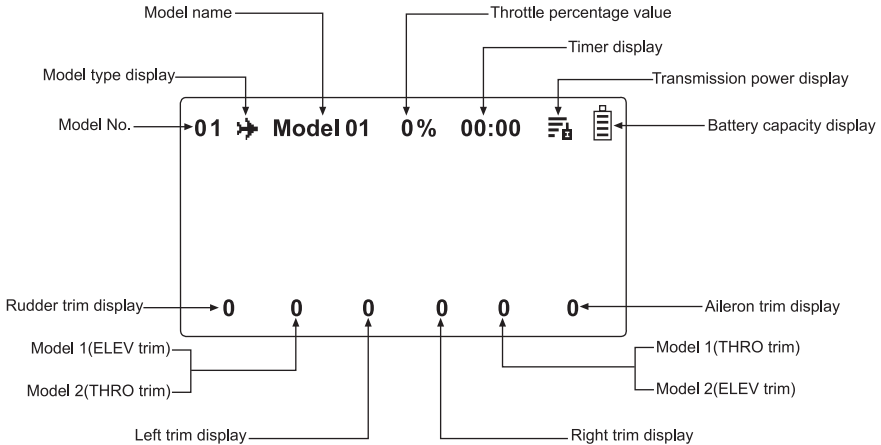

● Model Select

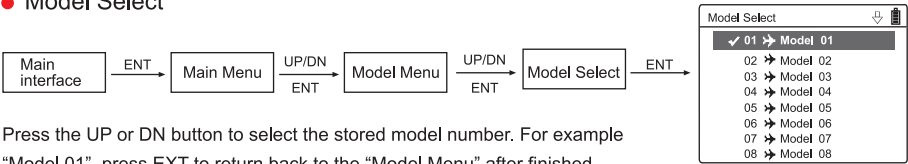

Press the UP or DN button to select the stored model number. For example "Model 01", press EXT to return back to the "Model Menu" after finished.

● Model Name

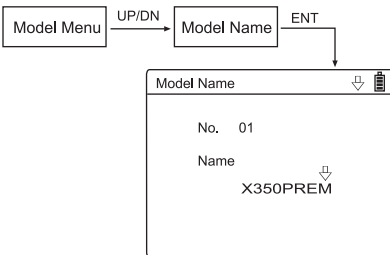

Press UP or DN button to select the characters which need to be changed, Name model "X350PREM". Press EXT to return to the "Model Menu".

● Wing Type

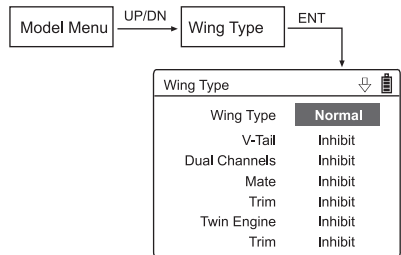

Press R or L to select "Normal", then press EXT to return to the "Model Menu".

● Sensor Setting



Press R or L to select “Active”.

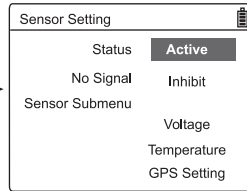

(1) Voltage Setting

Press UP or DN to select Voltage in the Sensor Setting. Press ENT to enter the Voltage interface.

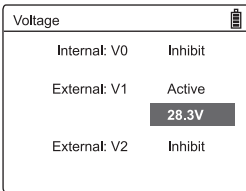

Internal shows the Radio battery voltage.

External shows the aircraft battery voltage.

The QR X350 Premium default voltage settings is 28.3 volts.

When the radio give you the low-voltage warning.

it is **URGENT to land as quickly as possible.**

* Optional you can adjust the voltage to 28.5

this will give you a earlier warning.

(2) GPS Receive Setting

Press UP or DN to select the GPS setting on the Sensor Setting interface, then press ENT to enter the GPS Setting interface.

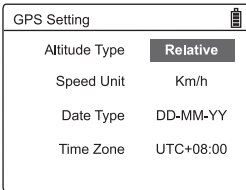

(2.1) Altitude Type setting:

Press R or L to select Absolute or Relative.

(2.2) Speed Unit setting:

Press R or L to select Km/h or Knot.

(2.3) Date Type setting:

Press R or L to select DD-MM-YY\ MM-DD-YY\ YY-MM-DD.

(2.4) Time Zone:

Press R or L to select Time Zone, then press EXT to return to the “Main Menu”.

● Reverse Switch

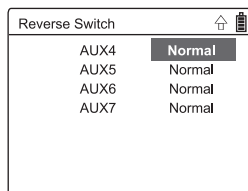
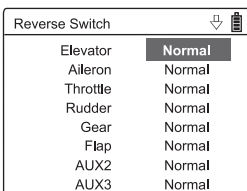
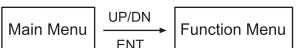

Press EXT to return back to the

“Function Menu” after finished.

● Servo Travel Adjust

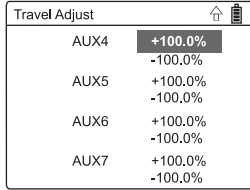
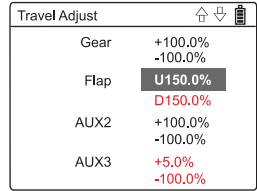
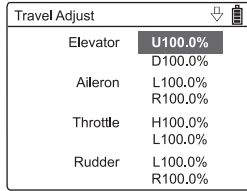

Press UP or DN to select Flap channel,
Press R or L to set as **U150.0%** and **D150.0%**.

Press UP or DN to select AUX3 channel,
press R or L to set **+5.0%**(5 means **Roundfly radius is 5 meters**)
and **-100.0%**, then press EXT to return Function Menu.

● Video Setting/OSD information

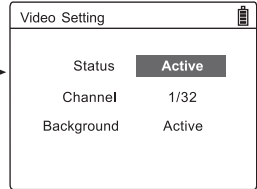

Status: Press R or L to select "Active".

Channel: press R or L to choose the video channel corresponding to the camera. It will display automatically "OSD" after connection.

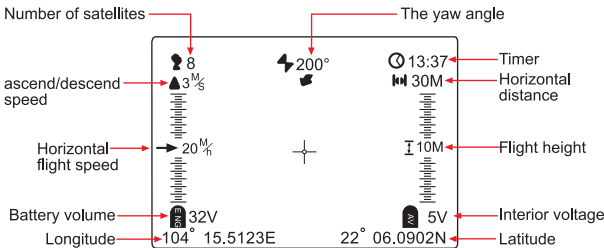

Background:
Press R or L to select Active,
Real-time image will be set
as background in Main Menu.

**Press EXT to switch full screen
or half screen to display image
and OSD information when in
the main interface**

● Senser Viem: select according to your needs

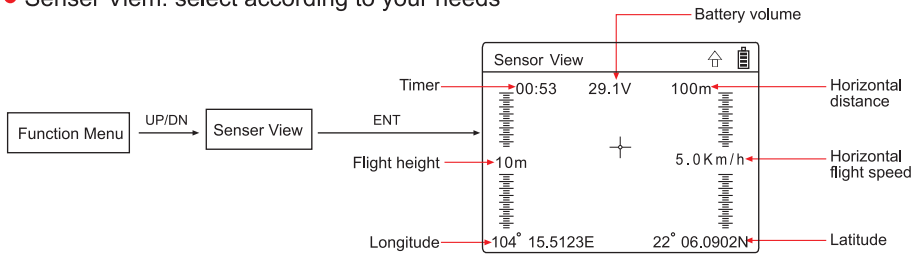

Press R or L to select viewport display. When the image is set as the background, Information will be displayed on the image.

QR X350 Premium

- Timer Setting: select according to your needs

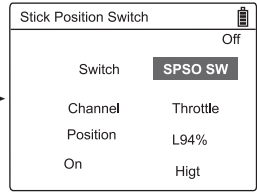

Switch: Press R or L to select “SPSO SW”.

Channel: Press R or L to select “Throttle”.

Position: Press L to set percentage(Suggested setting is L94%).

On setting: Press R or L to select “High” as rocker direction for on.

Move up and down of the throttle to check if the direction of the switch is set correctly.

Then press EXT to return to the “Main Menu”.

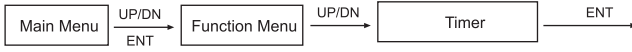

Type: Press R or L to select stopwatch or countdown.

Switch: Press R or L to select “SPSO SW”.

Press EXT to return back to the main interface when finished.

Usage: Toggle the throttle up to L94% to start the time, toggle the throttle down to L94% to stop the time, press DN to reset.

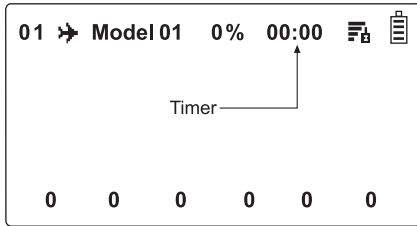

4.2 QR X350 Premium Main Controller Guideline

- ① GPS port: used to connect GPS module
- ② USB port: used to USB upgrade
- ③ Input switch
Interior ↔ Exterior
(Factory default the switch as interior position)
- ④ Data port

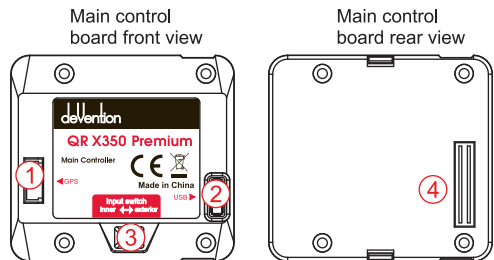

4.3 Camera Setting

● Video user guide

 Warm tips:

- A Micro SD card must be inserted into the camera before connecting the power, and should be removed after disconnecting the power. (A high speed SD card is recommended.)
- Insert the Micro SD card, and power on the camera. The red indicator lights indicate that the camera is initialized, The red light turned off indicates that the camera is in standby mode and initialization is complete.
- Insert Micro SD card, and power on the camera. The red indicator light blinking rapidly means the SD card needs to be formatted.

Switch	Instructions
Start/Stop Video Rec	<p>(1) Start video: turn the Start/Stop Video Rec switch from "0" position to "1" position, wait for 1-2 seconds, then return to the "0" position, the camera will start recording (the red indicator keeps flash with an interval of 0.5 second). The red indication of video status can be seen on the transmitter.</p> <p>Stop video: turn the Start/Stop Video Rec switch from "0" position to "1" position, wait for 1-2 seconds, then return to the "0" position, the camera will stop recording (the red indicator light turns off along with the red indicator light on transmitter).</p> <p>(2) You must stop recording to store the video on the SD card. The video will not be stored if you turn off the power without stopping the recording.</p>

4.4 Connect e8 charger instruction

Slide the power switch to the "ON" position when charging, press the power button for 3~5 seconds until the power indicator remains on.

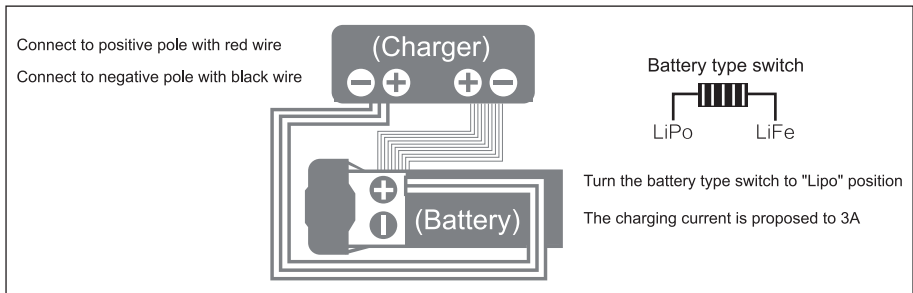

Tel.: (8620) 8491 5115 8491 5116

Fax.: (8620) 8491 5117

Email: heli@walkera.com
info@walkera.com

Add.: Taishi Industrial Park, Dongchong Town
nansha District, 511475 Guangzhou

devention

Specifications, contents of parts and availability
are subject to change, Walkera is not responsible
for inadvertent errors
in this publication.



Web: www.walkera.com

Warning: Changes or modifications to this unit not expressly approved by the party responsible for compliance could void the user's authority to operate the equipment.

NOTE: This equipment has been tested and found to comply with the limits for a Class B digital device, pursuant to Part 15 of the FCC Rules. These limits are designed to provide reasonable protection against harmful interference in a residential installation. This equipment generates, uses and can radiate radio frequency energy and, if not installed and used in accordance with the instructions, may cause harmful interference to radio communications.

However, there is no guarantee that interference will not occur in a particular installation. If this equipment does cause harmful interference to radio or television reception, which can be determined by turning the equipment off and on, the user is encouraged to try to correct the interference by one or more of the following measures:

- Reorient or relocate the receiving antenna.
- Increase the separation between the equipment and receiver.
- Connect the equipment into an outlet on a circuit different from that to which the receiver is connected.
- Consult the dealer or an experienced radio/TV technician for help.

This device complies with Part 15 of the FCC Rules. Operation is subject to the following two conditions:

- (1) this device may not cause harmful interference, and
- (2) this device must accept any interference received, including interference that may cause undesired operation.

“FCC RF Radiation Exposure Statement Caution: To maintain compliance with the FCC's RF exposure guidelines, place the product at least 20cm from nearby persons.”