



WK-2603

User Manual

Note: read though the manual before operation and keep it in a safe place for the future reference.



Content

Part one: General Information

1.0 Foreword	1	4.2 Wiring Diagram	6
1.1 Important Statements	1	4.3 WK-2603 Input Key Function	7
1.2 Safety Guidelines Needing Attention	1	5.0 Control Stick Length Adjustment	7
1.3 Attention before flight	2	5.1 Control Stick Tension Adjustment	7
2.0 Features	3	5.2 Neck Strap Usage	7
2.1 Transmitter WK-2603	3	5.3 Mechanical throttle switch methods	8
3.0 Specifications	3	5.3.1 Right-hand throttle switched to left-hand throttle	8
3.1 Transmitter Specification	3	5.3.2 Left-hand throttle switched to right hand	9
3.2 Receiver Specification	3	5.4 Stick Tension Adjustment	10
4.0 Face	4	6.0 Installation Requirements	10
4.1 Back	5		

Party two: Function Setup

1.0 Main Menu	12	6.2 PLT adjustment	17
2. 0 Swashplate type	12	7.0 Adjustment of gyro sensitivity and rudder mixing	18
3. 0 Channel reverse setup	13	7.1 Direction adjustment of rudder mixing	18
4.0 Buzzer setup	15	7.2 Adjustment of gyro sensitivity and rudder mixing	18
5.0 Exponential function	15	7.2.1 Adjustment of gyro sensitivity	18
5.1 Throttle curve and servo exponential function	15	7.2.2 Adjustment of rudder sensitivity	18
5.1.1 Adjustment for normal throttle curve	16	7.3 Dual Rate (D/R)	18
5.1.2 Adjustment for stunt throttle curve	16	7.4 Throttle limited height switch	19
5.1.3 Adjustment for servo exponential	16	8.0 Setting for compatibility	19
5.1.4 Compatibility setting for exponential function	17	8.1 Flight mode	19
6.0 PIT adjustment	17		
6.1 PIT adjustment	17		

Part one: General Information

1.0 Foreword

The WK-2603 adopts the frequency-hopping spread spectrum 2.4G technology which features automatic code pairing, ID assignment and high capacity of anti-jamming. it uses the graphic menu which features simple easy-to-read operation.

1.1 Important Statements

- (1) The transmitter is suitable for experienced radio controlled helicopter modelers beyond 14 years old.
- (2) Flying the model aircraft in approved ground is a must.
- (3) We are not responsible for any safety caused by operation, usage or control as soon as the transmitter is sold .
- (4) We consign our distributors to offer technical support and service after sale. Please contact the local distributors for problem solutions caused by usage, operation, maintenance, etc.

1.2 Safety Needing Attention

- (1) Far away from obstacle and people

RC helicopter in flight is uncertain of flight speed and status, which potential risk exists in. when flying, please keep your RC helicopter far away from people, high buildings, high-tension line, etc, and avoid operating in rain, storms, thunder and lightening.

- (2) Away from humidity environment

RC helicopter should be kept away from humidity and vapor because it is composed of complicated precise electronic elements and mechanic parts.

(3) Proper operation

Please use Walkera original spare parts to upgrade, modify or maintain your equipment in order to assure its safety. Please operate your equipment within the range of functions permitted. It is forbidden to use of the safety laws or regulations.

(4) Safety operation

Please fly your equipment according to your body status and flight skills. Fatigue, listlessness and miss-operation will increase the possibilities of accidental hazard.

(5) Away from heat source

The inside of the transmitter is composed of many precise electronic components and mechanical parts. Keep it far away from heat sources and sunshine to avoid distortion, or even damage caused by high temperature.

(6) Correct Charging Method

It is prohibited to charge the battery by the CHG jack when using a non-rechargeable battery pack.

1.3 Attention before flight

(1) Ensure the battery packs of both transmitter and receiver are fully charged (saturated).

(2) Ensure both the throttle stick and the throttle trim of your transmitter stay at the lowest positions before operation.

(3) Please strictly obey the order of turn-on and turn-off before operation. When starting your flight, turn on your transmitter first, then connect the battery to the heli. When turning off the heli, disconnect the battery first, then turn off the transmitter. An upset in the order of connection may cause your helicopter to lose control. Please cultivate a correct habit of turn-on and turn-off.

(4) Ensure the directions and actions of the servos are correct when executing commands of the transmitter. Using a broken servo will result in unforeseen dangers.

2.0 Features

2.1 Transmitter WK-2603

1. The WK-2603 adopts 2.4G frequency-hopping spread spectrum technology and features automatic code pairing and ID assignment.
2. Graphic display menu is simple to understand and to set.
3. The appearance design accords with ergonomics and features easy holding. The LCD screen with backlight and graphic interface looks more personalized.
4. Both the length and tension of the stick can be adjustable. It is convenient to freely switch among the 4 stick modes.

3.0 Specifications

3.1 Transmitter Specification:

Encoder	6-channel micro computer system
Frequency	2.4G spread spectrum
Output Power	$\leq 10\text{mW}$ or $\leq 100\text{mW}$
Current Drain	$\leq 120\text{mA}$ (at 10mW) or $\leq 230\text{mA}$ (at 100mW)
Power Source	1.2V \times 8NiCad(9.6V600mAh) or 1.5V \times 8 AA dry batteries
Output Pulse	1050-1850Ms(1500 Neutral)

3.2 Receiver Specification:

Type	Type: 2.4G 7 channel
Sensitivity	95dbm
Frequency Interval	$\geq 4\text{M}$
Weight	10g
Dimension	39 \times 28.5 \times 14.5mm
Receiver Battery	-4.8V 1100mAh

WK-2603

4.0 Face



WK-2603

4.1 Back

Charging Jack: Input Voltage: 12V, Current: 50-100mA. Polarity: $\oplus \rightarrow \bullet \rightarrow \ominus$

It's only fit for the rechargeable battery pack. Non-rechargeable one is strictly forbidden to use the charge function!

Analog signals output jack/ training jack (DSC): for simulator flight practice via computer (You need a software and its dongle which are available in hobby stores), and for training.



4.2 Wiring Diagram:

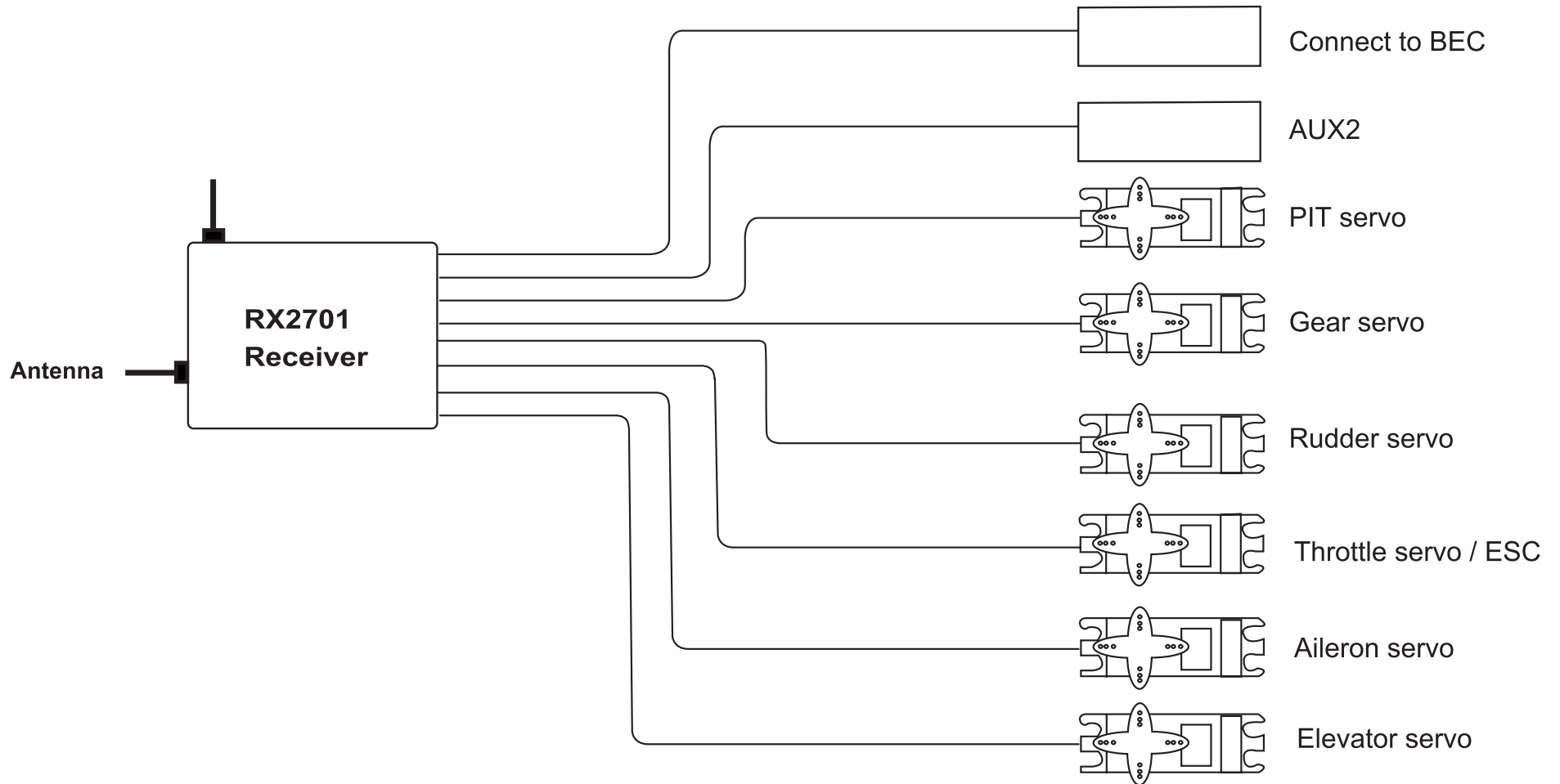

4.3 WK-2603 Input Key Function

- EXT:** Reset key, press EXT to exit the setting mode.
- ENT:** Enter key, press ENT to enter the setting and confirmation status.
- UP:** Selection key, moves cursor up to the previous function item.
- DN:** Selection key, moves cursor down to the next function item.
- +R:** Change the setting.
- L-:** Change the setting.

5.0 Control Stick Length Adjustment

Prolong the stick length: CCW rotate the stick head until the length you hope, and then CCW tighten the stick sleeve;

Shorten the stick length: CW rotate the stick sleeve until the length you hope, and then CW tighten the stick head.

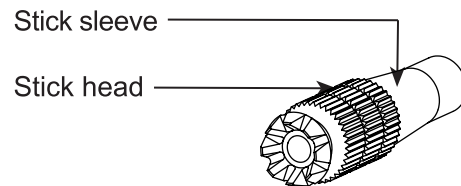

5.1 Control Stick Tension Adjustment

Remove the 6 screws in the back cover of WK-2603, and remove the transmitter back cover (Be careful not to break the wires). Then use a Phillips screwdriver to adjust each screw on the throttle arresting spring for the desired tension (Note: CW rotate to tighten the stick and CCW rotate to loosen).

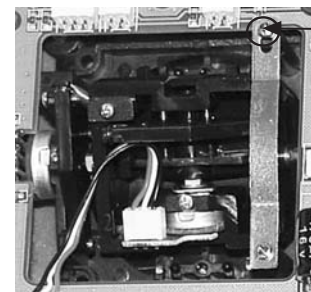

Right Throttle Stick

Control Stick
Tension
Adjustment Screw

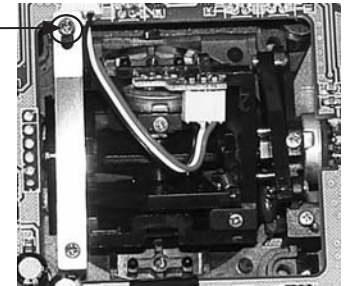

Left Throttle Stick

5.2 Neck Strap Usage

The neck strap can be hooked on the face of the WK-2603 transmitter. The Hook located at the center helps to get optimal balance of the transmitter.



Neck Strap Eyelet

5.3 Mechanical throttle switch methods

5.3.1 Right-hand throttle switched to left-hand throttle

A. The stick position change

Remove the battery pack and the 6 fixing screws in the back of transmitter, and then remove the transmitter back case (Be careful not to break the wires inside). Use a Phillips screwdriver to loosen the linkage screws, screw A, screw B and the throttle arresting spring in the right throttle position. Then mount them to the corresponding positions in the left throttle position. Adjust screw A according to the personal hand feeling (adjust the tension of the throttle stick). Then install the transmitter back case.

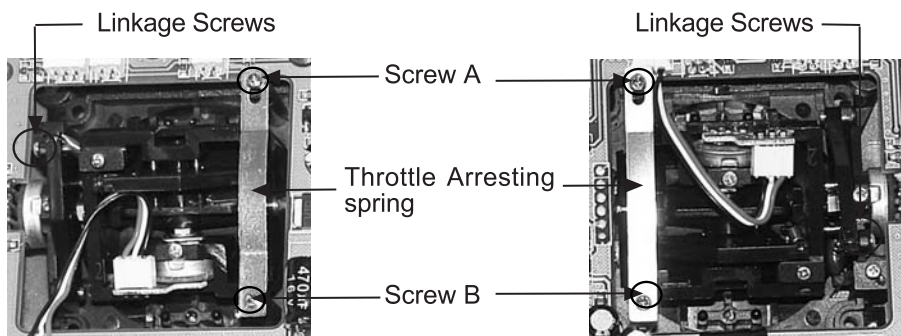

Right Throttle Position

Left Throttle Position

B. The data switch

Press ENT and both STICK MOD and its current status of stick (any one number from 1 through 4) flash. That means the setting status is entered. Press R or L to flash the number 1 or 3 behind STICK MOD. Press ENT to confirm and exit by pressing EXT.

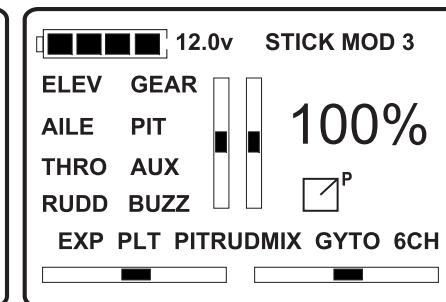
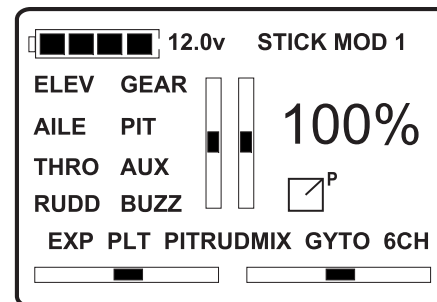

The right-hand throttle includes two modes: MODE 1 and MODE 3; The left-hand includes another two modes: MODE 2 and MODE 4. Refer to the following sketch map:

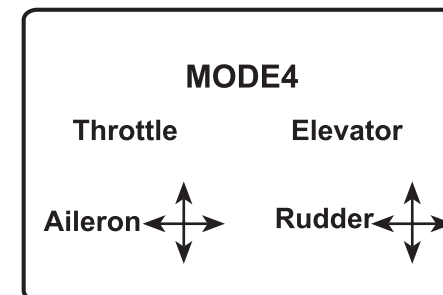
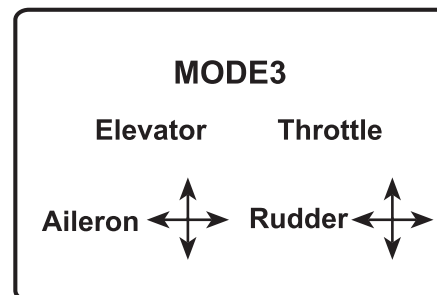
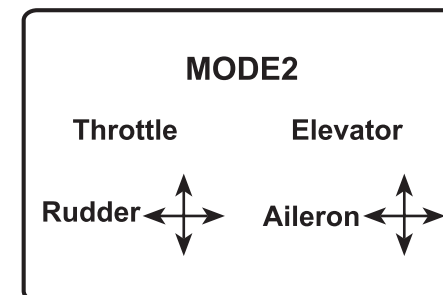
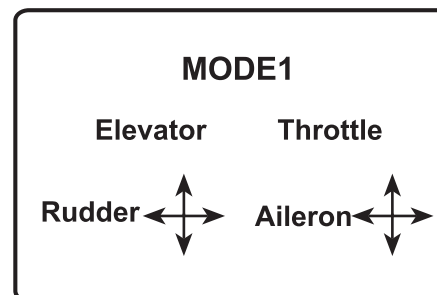

The switch from right hand throttle to left is completed and your WK-2603 is ready for normal flying.

5.3.2 Left-hand throttle switched to right hand

A. The stick position change

Remove the battery pack and the 6 fixing screws in the back of transmitter, and then remove the transmitter back case (Be careful not to break the wires inside). Use a Phillips screwdriver to loosen the linkage screws, screw A, screw B and the throttle arresting spring in the left throttle position. Then mount them to the corresponding positions in the right throttle position. Adjust screw A according to the personal hand feeling (adjust the tension of the throttle stick). Then install the transmitter back case.

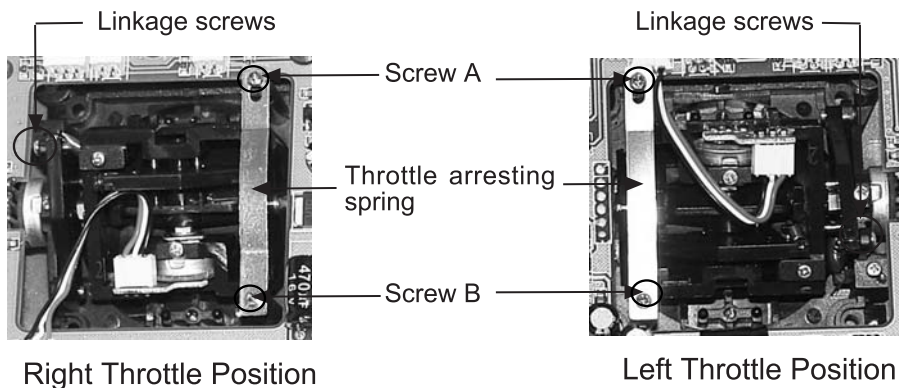

B. The data switch

Press ENT and both STICK MOD and its current status of stick (any one number of 1 through 4) are flashing. That means the setting status is entered. Press R or L to flash the number 2 or 4 behind STICK MOD. Press ENT to confirm and exit by pressing EXT.

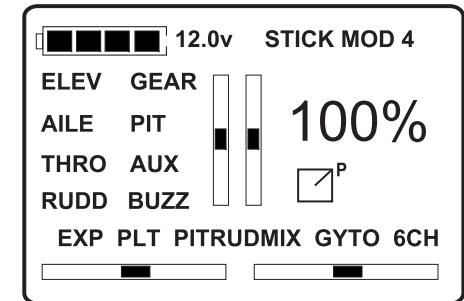
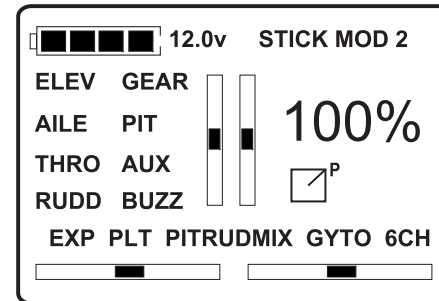

The left-hand includes two modes: MODE 2 and MODE 4; The right-hand throttle includes another two modes: MODE 1 and MODE 3. Refer to the following sketch map:

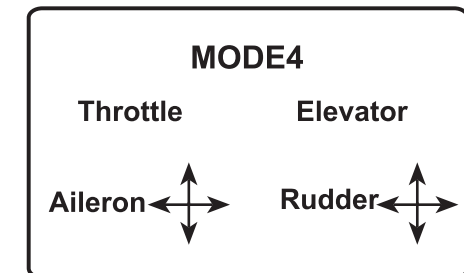
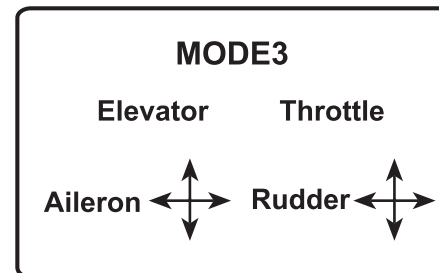
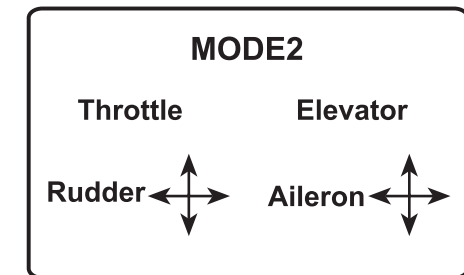
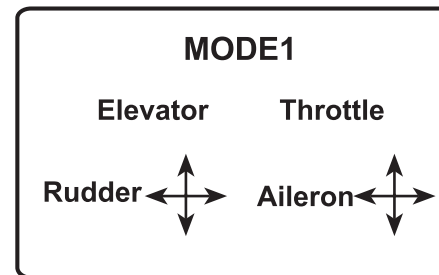

The switch from left hand throttle to right is completed and your WK-2603 is ready for normal flying.

Note: Pay attention to the strength when removing and adjusting the screws. Excessive strength may damage them.