

INSIGNIA™

v1  
R2

USER GUIDE

# Rugged Speaker System

NS-HMPS3018

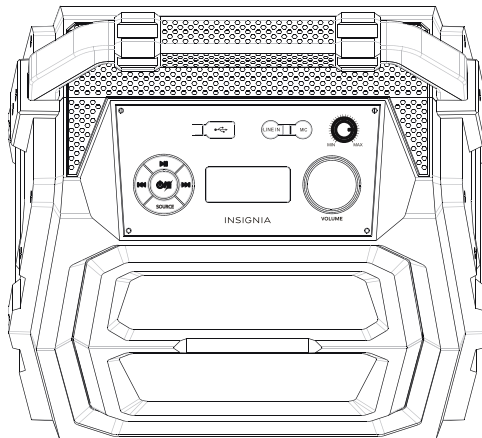

Before using your new product, please read these instructions to prevent any damage.

## Contents

Introduction .....	2
Important safety instructions .....	2
Package contents .....	5
Features .....	5
Top view .....	5
Side view .....	6
Setting up your speaker system .....	6
Choosing and evaluating your sound source .....	6
Powering your speaker system .....	6
Setting up and connecting your sound source .....	7
Using your speaker system .....	9
Listening to your speaker system .....	9
Controlling basic playback .....	10
Maintaining your speaker system .....	10
Troubleshooting .....	10
Specifications .....	12
Legal notices .....	12
ONE-YEAR LIMITED WARRANTY .....	14

## Introduction

Congratulations on your purchase of an Insignia Rugged Speaker System with Bluetooth. It features a variety of connections and sound source options.

This user guide explains how to correctly install, operate, and get the best performance from your speaker system. Read this user guide carefully before installing your system, and then keep it handy for quick reference.

## Important safety instructions

- 1 Read these instructions.
- 2 Keep these instructions.
- 3 Heed all warnings.
- 4 Follow all instructions.
- 5 Do not use this apparatus near water.
- 6 Clean only with dry cloth.
- 7 Do not block any ventilation openings. Install in accordance with the manufacturer's instructions.

- 8 Do not install near any heat sources such as radiators, heat registers, stoves, or other apparatus (including amplifiers) that produce heat.
- 9 Do not defeat the safety purpose of the polarized or grounding-type plug. A polarized plug has two blades with one wider than the other. A grounding type plug has two blades and a third grounding prong. The wide blade or the third prong are provided for your safety. If the provided plug does not fit into your outlet, consult an electrician for replacement of the obsolete outlet.
- 10 Protect the power cord from being walked on or pinched particularly at plugs, convenience receptacles, and the point where they exit from the apparatus.
- 11 Only use attachments/accessories specified by the manufacturer.
- 12 Use only with the cart, stand, tripod, bracket, or table specified by the manufacturer, or sold with the apparatus. When a cart is used, use caution when moving the cart/apparatus combination to avoid injury from tip-over.



PORTABLE CART WARNING  
(Symbol provided by RETAC)

- 13 Unplug this apparatus during lightning storms or when unused for long periods of time.
- 14 Refer all servicing to qualified service personnel. Servicing is required when the apparatus has been damaged in any way, such as power-supply cord or plug is damaged, liquid has been spilled or objects have fallen into the apparatus, the apparatus has been exposed to rain or moisture, does not operate normally, or has been dropped.

**WARNING:** To reduce the risk of fire or electric shock, do not expose this apparatus to rain or moisture.



The lightning flash with arrowhead symbol within an equilateral triangle is intended to alert the user to the presence of uninsulated "dangerous voltage" within the product's enclosure that may be of sufficient magnitude to constitute a risk of electrical shock to persons.



The exclamation point, within an equilateral triangle, is intended to alert the user to the presence of important operating and maintenance (servicing) instructions in the literature accompanying the product.

## Placement

- This speaker system is made out of plastic and is therefore sensitive to extreme temperatures and humidity. Do not put it in locations subject to direct sunlight or in humid places, such as near an air conditioner, humidifier, bathroom, or kitchen.
- Do not put water or other liquids close to the speaker system. If liquid is spilled on top of the speaker system, it may be damaged.
- The speaker system should be placed on a sturdy, flat surface that is free from vibration. Do not put the speaker system on an uneven or unstable surface, where it may fall and cause damage.

## Using close to a TV or computer

Some older TVs and computer monitors are magnetically sensitive devices. They are likely to suffer discoloration or picture distortion when conventional speakers are placed nearby. If discoloration problems persist, try moving the speaker system away from your TV or monitor.

# Package contents

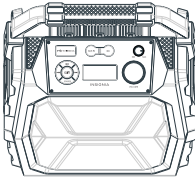

Speaker system



AC power cord

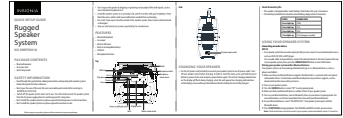

Quick Setup Guide

# Features

## Top view

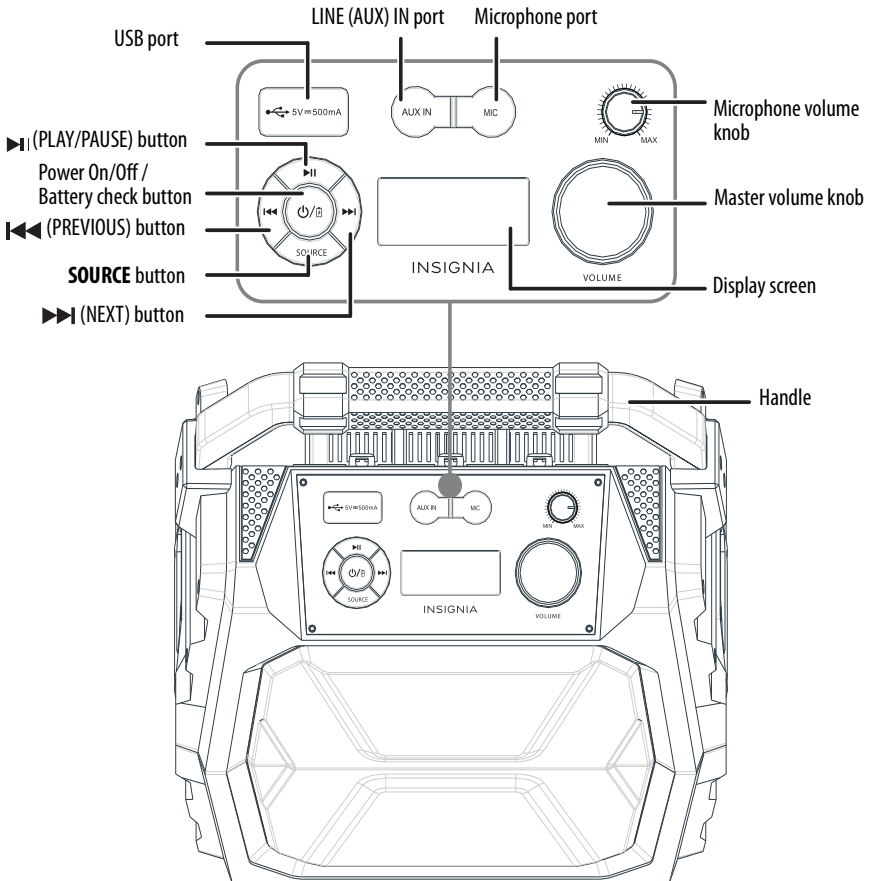

## Side view

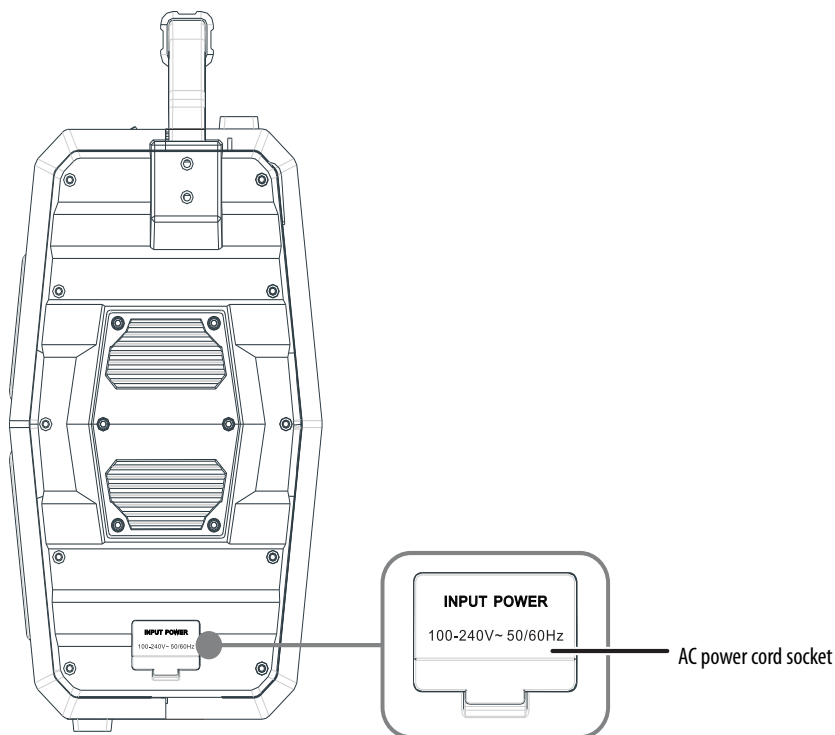

## Setting up your speaker system

### Choosing and evaluating your sound source

- Look at your sound source device, such as a TV, DVD/Blu-ray player, smartphone, or USB thumbdrive to identify the type of connection it requires. Choose the connection option below that fits your audio source. You can connect several devices and switch the sound source as required.

#### Caution

Turn off all devices while you are making connections.

### Powering your speaker system

After you have connected your speaker system to an audio source, you need to connect it to an AC power outlet.

- 1 Connect the AC power cord to the **AC power input socket** on the side of the speaker system.

- 2 Plug the other end of the AC power cord into a power outlet or surge protector.

## Charging the batteries

Your speaker system comes with built-in rechargeable batteries so you can use it in places without an AC connection. The batteries are charged automatically when you plug your speaker system into an AC power outlet.

To determine the current charge level of your batteries, press the Power On/Off/Battery check button (when your speaker system is powered on) on the top of your speaker system. The charge is indicated by the number of lines shown on the display.

- If one line lights, the charge level is 25%
- If two lines light, the charge level is 50%
- If three lines light, the charge level is 75%
- If all four lines light, the batteries are fully charged

## Setting up and connecting your sound source

### FM Tuner

- 1 Turn on your speaker system.
- 2 Press the **SOURCE** button on the speaker system repeatedly to select "TUNER".

### Bluetooth

Before you can use your speaker system with a Bluetooth device, you need to pair your device to the speaker system.

### Pairing your devices

- 1 Turn on your speaker system.
- 2 Place the Bluetooth device within 30 ft. (10 m) of your speaker system.
- 3 Press the **SOURCE** button on the speaker system repeatedly to select "BT". This puts your speaker system into pairing mode.
- 4 Navigate to your device's Bluetooth settings, turn on Bluetooth, then search for available devices. For additional information on pairing your device, see your device's documentation.
- 5 On your Bluetooth device, select "**NS-HMPS3018**" from the device list. Repeat steps 1-4 if "**NS-HMPS3018**" is not displayed.

- 6 If a PIN code is requested, enter "0000."

#### Notes

- Some devices, such as an iPhone, connect immediately after pairing. Other devices, such as notebook computers, may ask you if you wish to connect.
- Your speaker system saves pairing information for up to eight devices. However, it can only be connected and play content from one device at a time.
- When you turn on your speaker system, it automatically connects to the last connected device if that device is in range. To connect to a different paired device, turn off Bluetooth or unpair from the currently paired device and manually connect to the other paired device.

### Disconnecting your devices

- Turn off the Bluetooth function on your device.

### Reconnecting to a paired device

Your speaker system loses the Bluetooth connection if you...	To reconnect...
Turn it off.	Turn on your speaker system. Your speaker system searches for the last connected Bluetooth device and reconnects.
Move the Bluetooth device out of range.	Move your Bluetooth device within 30 feet of your speaker system.
Turn off your Bluetooth device.	Turn on your Bluetooth device, then make sure that Bluetooth is on.
Turn off Bluetooth on your Bluetooth device.	Turn on Bluetooth on your Bluetooth device.
Connect your Bluetooth device to another Bluetooth device.	Disconnect your Bluetooth device from the other Bluetooth device, then set your device to pairing mode. Select "NS-HMPS3018" on your Bluetooth device.

#### Note

If a device does not automatically reconnect, you may need to reselect "NS-HMPS3018" on your Bluetooth device.

### Receiving a phone call while playing music

- When a call is received while playing music through a phone, the music stops automatically.
- When the call ends, depending on the settings on your phone, the current track may resume playback.



### 3.5mm AUX (LINE IN) connection

- 1 Turn on your speaker system.
- 2 Press the **SOURCE** button on the speaker system repeatedly to select "LINE".
- 3 Connect one end of a 3.5 mm audio cable to your speaker system's LINE IN jack.
- 4 Connect the other end of the 3.5 mm audio cable to the headphone or **AUX Output** on your audio source device.

### USB connection

- 1 Turn on your speaker system.
- 2 Press the **SOURCE** button on the speaker system repeatedly to select "USB".
- 3 Plug a USB thumbdrive into the USB port on the top of your speaker system.

#### Note

You can also plug a memory card reader into the USB port to play audio from a memory card.

### Microphone

- Plug your microphone into the microphone jack on the top of your speaker system.

## Using your speaker system

This system lets you access five different sound sources (TUNER (FM), AUX (LINE IN), USB, Microphone, and Bluetooth (BT)).

### Listening to your speaker system

- 1 Turn on your speaker system.
- 2 Press the **SOURCE** button on the speaker system repeatedly to select the audio source you want, or to select TUNER mode (TUNER will appear on the display).
- 3 Turn on the audio source device connected to your speaker system and begin playback.
- 4 Adjust the volume on your speaker system or the source audio device to a comfortable level.

#### Warning

Continuous use of high volume sound may permanently damage your hearing.

## Controlling basic playback

Button	Function
<b>SOURCE</b>	Press repeatedly to select the sound source for your speaker system. Choices include <b>TUNER</b> (FM), <b>AUX</b> (LINE IN), <b>USB</b> , and <b>BT</b> (Bluetooth)
<b>▶▶</b> (Play/Pause)	<b>TUNER</b> mode - Press and hold to autoscan for channels. <b>USB</b> or <b>BT</b> - Press to begin playback. Press again to pause playback. <b>BT</b> - Press and hold to disconnect Bluetooth.
<b>▶▶▶</b> (Next)	<b>TUNER</b> mode - Press to skip to the next preset station. Press to fine tune the station frequency up. <b>USB</b> or <b>BT</b> - Press to skip to the next track.
<b>◀◀</b> (Previous)	<b>TUNER</b> mode - Press to skip to the previous preset station. Press to fine tune the station frequency up. <b>USB</b> or <b>BT</b> - Press to skip to the previous track.

### Microphone playback

- When using a microphone with your speaker system, control the volume with the Microphone Volume knob located on the top of your speaker system.

## Maintaining your speaker system

### Cleaning your speaker system

Clean the surface of your speaker system with a soft, dry cloth.

## Troubleshooting

Check this list for a possible troubleshooting solution before calling for service.

Problem	Possible Solutions
The power does not come on.	<ul style="list-style-type: none"> <li>• Make sure that the AC power cord is securely plugged into a working power outlet and the speaker system.</li> </ul>
There is no sound or very low-level sound is heard from the speaker system.	<ul style="list-style-type: none"> <li>• Make sure that you are connected to an audio <b>OUTPUT</b> jack on your sound source. The port will not send audio out if it is an input jack.</li> <li>• Make sure that the volume level of the speaker system is set to an adequate level.</li> <li>• If you are using Bluetooth, turn up the volume on your Bluetooth device.</li> <li>• Make sure that the correct audio source is selected. Press the <b>SOURCE</b> button repeatedly to switch to the correct audio source.</li> <li>• Make sure that the power is on and all connections are secure.</li> <li>• If you are using a 3.5 mm cable connection, make sure that the volume is turned up on your sound source.</li> <li>• Make sure that the audio cable you are using is not damaged or broken. Try using another one.</li> </ul>

Problem	Possible Solutions
Your speaker system is not working properly.	<ul style="list-style-type: none"> <li>• Unplug the AC power cord from the wall outlet and then try plugging it in again after 30 seconds.</li> <li>• Make sure that the audio cable you are using is not damaged or broken. Try using another one.</li> </ul>
The sound is breaking up or buzzing.	<ul style="list-style-type: none"> <li>• Make sure that you are connected to an audio <b>OUTPUT</b> jack on your sound source. The port will not send audio out if it is an input jack.</li> <li>• Make sure that all connections are secure and cables are not broken or damaged.</li> <li>• Connect to a different source device (such as a TV or DVD/Blu-ray player) to see if the buzzing still occurs. If it does not, this may indicate an issue with the original source device.</li> <li>• Try connecting both the audio source device and the speaker system to other devices to make sure the jacks on both devices are still working.</li> <li>• Make sure that the audio cable you are using is not damaged or broken. Try using another one.</li> </ul>
There is no sound or low volume in Bluetooth mode.	<ul style="list-style-type: none"> <li>• Make sure that your Bluetooth device is turned on, Bluetooth is turned on, and "NS-HMPS3018" is selected.</li> <li>• Turn up the volume on your speaker system.</li> <li>• Turn up the volume on your Bluetooth device.</li> <li>• Make sure that your Bluetooth device is not muted.</li> <li>• Make sure that you are playing audio from your Bluetooth device.</li> <li>• Make sure that you have selected the Bluetooth source on your speaker system.</li> <li>• Make sure that your speaker system is not paired to another Bluetooth device.</li> <li>• Make sure that your Bluetooth device is not paired to a different Bluetooth speaker.</li> </ul>
My speaker system won't connect to my Bluetooth device.	<ul style="list-style-type: none"> <li>• Shorten the distance between your speaker system and your Bluetooth device.</li> <li>• Turn your devices off, then on. Re-pair your speaker system and your Bluetooth device.</li> <li>• Make sure that your speaker system is not paired to another Bluetooth device.</li> <li>• Make sure that your speaker system and Bluetooth device are both in pairing mode.</li> <li>• Make sure that your Bluetooth device is not connected to any other device.</li> <li>• Make sure that you have selected "NS-HMPS3018" on your Bluetooth device.</li> </ul>
My Bluetooth device keeps unpairing.	<ul style="list-style-type: none"> <li>• Shorten the distance between your speaker system and your Bluetooth device.</li> <li>• If the battery on your Bluetooth device is low, recharge the battery.</li> </ul>
"NS-HMPS3018" does not appear on my Bluetooth device.	<ul style="list-style-type: none"> <li>• Shorten the distance between your speaker system and your Bluetooth device.</li> <li>• Put your speaker system into pairing mode, then refresh your list of Bluetooth devices. For more information, see the documentation that came with your Bluetooth device.</li> <li>• Make sure that your Bluetooth device is visible to other devices. For more information, see the documentation that came with your Bluetooth device.</li> </ul>

# Specifications

Designs and specifications are subject to change without notice.

Power requirement	100/240 V ~ 50/60 Hz
Power consumption	38 Watts
Amplifier output	30 Watts
Frequency response	±3dB (20 Hz ~ 20 kHz)
Dimensions (approx.) (W × D × H)	12.3 x 7.5 x 16.1 in. (313 x 190 x 410 mm)
Weight (net)	12.35 lb. (5.6 kg)
FM Tuner range	87.5 MHz - 107.9 MHz
Audio options	Tuner (FM) LINE (AUX) IN Bluetooth USB Microphone

## Legal notices

### FCC Part 15

This device complies with Part 15 of the FCC Rules. Operation of this product is subject to the following two conditions: (1) this device may not cause harmful interference, and (2) this device must accept any interference received, including interference that may cause undesired operation.

This equipment has been tested and found to comply within the limits for a class B digital device, pursuant to Part 15 of the FCC Rules. These limits are designed to provide reasonable protection against harmful interference in a residential installation. This equipment generates, uses, and can radiate radio frequency energy and, if not installed and used in accordance with the instructions, may cause harmful interference to radio communications. However, there is no guarantee that interference will not occur in a particular installation. If this equipment does cause harmful interference to radio or television reception, which can be determined by turning the equipment off and on, the user is encouraged to try to correct the interference by one or more of the following measures:

- Reorient or relocate the receiving antenna.
- Increase the separation between the equipment and receiver.
- Connect the equipment into an outlet on a circuit different from that to which the receiver is connected.
- Consult the dealer or an experienced technician for help.

### FCC warning

Changes or modifications not expressly approved by the party responsible for compliance with the FCC Rules could void the user's authority to operate this equipment.

### Canada IC statement

This device complies with Industry license-exempt RSS standard(s). Operation is subject to the following two conditions: (1) this device may not cause interference, and (2) this device must accept any interference, including interference that may cause undesired operation of the device.

Ce dispositif est conforme à la norme de l'industrie RSS exempts de licence (s). Son fonctionnement est soumis aux deux conditions suivantes: (1) cet appareil ne peut pas provoquer d'interférences et (2) cet appareil doit accepter toute interférence, y compris les interférences qui peuvent causer un mauvais fonctionnement du dispositif."

This equipment complies with IC radiation exposure limits set forth for an uncontrolled environment.

Cet équipement est conforme à l'exposition aux rayonnements IC limites établies pour un environnement non contrôlé.

# ONE-YEAR LIMITED WARRANTY

## Definitions:

The Distributor\* of Insignia branded products warrants to you, the original purchaser of this new Insignia-branded product ("Product"), that the Product shall be free of defects in the original manufacturer of the material or workmanship for a period of one (1) year from the date of your purchase of the Product ("Warranty Period").

For this warranty to apply, your Product must be purchased in the United States or Canada from a Best Buy branded retail store or online at [www.bestbuy.com](http://www.bestbuy.com) or [www.bestbuy.ca](http://www.bestbuy.ca) and is packaged with this warranty statement.

## How long does the coverage last?

The Warranty Period lasts for 1 year (365 days) from the date you purchased the Product. Your purchase date is printed on the receipt you received with the Product.

## What does this warranty cover?

During the Warranty Period, if the original manufacture of the material or workmanship of the Product is determined to be defective by an authorized Insignia repair center or store personnel, Insignia will (at its sole option): (1) repair the Product with new or rebuilt parts; or (2) replace the Product at no charge with new or rebuilt comparable products or parts. Products and parts replaced under this warranty become the property of Insignia and are not returned to you. If service of Products or parts are required after the Warranty Period expires, you must pay all labor and parts charges. This warranty lasts as long as you own your Insignia Product during the Warranty Period. Warranty coverage terminates if you sell or otherwise transfer the Product.

## How to obtain warranty service?

If you purchased the Product at a Best Buy retail store location, please take your original receipt and the Product to any Best Buy store. Make sure that you place the Product in its original packaging or packaging that provides the same amount of protection as the original packaging. If you purchased the Product from a Best Buy online web site ([www.bestbuy.com](http://www.bestbuy.com) or [www.bestbuy.ca](http://www.bestbuy.ca)), mail your original receipt and the Product to the address listed on the web site. Make sure that you put the Product in its original packaging or packaging that provides the same amount of protection as the original packaging.

To obtain warranty service, in the United States call 1-888-BESTBUY or in Canada call 1-866-BESTBUY. Call agents may diagnose and correct the issue over the phone.

## Where is the warranty valid?

This warranty is valid only in the United States and Canada at Best Buy branded retail stores or websites to the original purchaser of the product in the county where the original purchase was made.

## What does the warranty not cover?

This warranty does not cover:

- Customer instruction/education
- Installation
- Set up adjustments
- Cosmetic damage
- Damage due to weather, lightning, and other acts of God, such as power surges
- Accidental damage
- Misuse
- Abuse
- Negligence
- Commercial purposes/use, including but not limited to use in a place of business or in communal areas of a multiple dwelling condominium or apartment complex, or otherwise used in a place of other than a private home.

- Modification of any part of the Product, including the antenna
- Display panel damaged by static (non-moving) images applied for lengthy periods (burn-in).
- Damage due to incorrect operation or maintenance
- Connection to an incorrect voltage or power supply
- Attempted repair by any person not authorized by Insignia to service the Product
- Products sold “as is” or “with all faults”
- Consumables, including but not limited to batteries (i.e. AA, AAA, C etc.)
- Products where the factory applied serial number has been altered or removed
- Loss or Theft of this product or any part of the product
- Display panels containing up to three (3) pixel failures (dots that are dark or incorrectly illuminated) grouped in an area smaller than one tenth (1/10) of the display size or up to five (5) pixel failures throughout the display. (Pixel based displays may contain a limited number of pixels that may not function normally.)
- Failures or Damage caused by any contact including but not limited to liquids, gels or pastes.

REPAIR REPLACEMENT AS PROVIDED UNDER THIS WARRANTY IS YOUR EXCLUSIVE REMEDY FOR BREACH OF WARRANTY. INSIGNIA SHALL NOT BE LIABLE FOR ANY INCIDENTAL OR CONSEQUENTIAL DAMAGES FOR THE BREACH OF ANY EXPRESS OR IMPLIED WARRANTY ON THIS PRODUCT, INCLUDING, BUT NOT LIMITED TO, LOST DATA, LOSS OF USE OF YOUR PRODUCT, LOST BUSINESS OR LOST PROFITS. INSIGNIA PRODUCTS MAKES NO OTHER EXPRESS WARRANTIES WITH RESPECT TO THE PRODUCT, ALL EXPRESS AND IMPLIED WARRANTIES FOR THE PRODUCT, INCLUDING, BUT NOT LIMITED TO, ANY IMPLIED WARRANTIES OF AND CONDITIONS OF MERCHANTABILITY AND FITNESS FOR A PARTICULAR PURPOSE, ARE LIMITED IN DURATION TO THE WARRANTY PERIOD SET FORTH ABOVE AND NO WARRANTIES, WHETHER EXPRESS OR IMPLIED, WILL APPLY AFTER THE WARRANTY PERIOD. SOME STATES, PROVINCES AND JURISDICTIONS DO NOT ALLOW LIMITATIONS ON HOW LONG AN IMPLIED WARRANTY LASTS, SO THE ABOVE LIMITATION MAY NOT APPLY TO YOU. THIS WARRANTY GIVES YOU SPECIFIC LEGAL RIGHTS, AND YOU MAY ALSO HAVE OTHER RIGHTS, WHICH VARY FROM STATE TO STATE OR PROVINCE TO PROVINCE.

Contact Insignia:

For customer service please call 1-877-467-4289 (U.S. and Canada) or 01-800-926-3000 (Mexico)

[www.insigniaproducts.com](http://www.insigniaproducts.com)

INSIGNIA is a trademark of Best Buy and its affiliated companies.

Distributed by Best Buy Purchasing, LLC

7601 Penn Ave South, Richfield, MN 55423 U.S.A.

©2017 Best Buy. All rights reserved.

**Made in China**

# INSIGNIA™

[www.insigniaproducts.com](http://www.insigniaproducts.com)

1-877-467-4289 (U.S. and Canada) or 01-800-926-3000 (Mexico)

INSIGNIA is a trademark of Best Buy and its affiliated companies.

Distributed by Best Buy Purchasing, LLC

7601 Penn Ave South, Richfield, MN 55423 U.S.A.

©2017 Best Buy. All rights reserved.

**Made in China.**

V1 ENGLISH  
17-0059