

四川爱联

WIFI-2-R821USA1A

IEEE 802.11a/ b/g/n/ac 1T1R USB2.0 Wi-Fi Module with BT 4.0

特性 Features :

- **接收制式 Reserving System**
 - IEEE Std. 802.11a
 - IEEE Std. 802.11b
 - IEEE Std. 802.11g
 - IEEE Std. 802.11n
 - IEEE Std. 802.11ac
 - BT4.0
- **双波段 Dual Band**
 - 2.4G&5.8G
- **结构大小 Size**
 - 19.00mm x 17.00mm x 2.60mm



四川爱联科技有限公司

Sichuan iLink Technology Co.,Ltd

地址 Add: 四川省绵阳市安州工业园区
Anzhou,Industrial park,Mianyang,Sichuan

传真 Fax : +86-0816-2416943

网 址: <http://www.changhong.com>

技术 热线:

客户确认反馈

Feedback of customer's Confirmation

经确认，我方承认该规格书
We accept the specification after Confirmed

客户名称 Customer name	客户签字 Customer signature	确认日期 Confirmation Date

请签字后将此页与首页按以下地址回传我公司，谢谢！



Please feed back this paper and first paper after your signature by the address,thanks!

地址：四川省绵阳市安州工业园区

ADD: Anzhou,Industrial park,Mianyang,Sichuan

公司：四川爱联科技有限公司

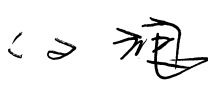
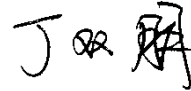
Factory: Sichuan iLink Technology Co.,Ltd.

批准 Approved	审核 Checked	拟制 Designed	产品 Product	WIFI 模组 WIFI MODULE
			型号 Model	WIFI-2-R821USA1A
			日期 Date	2017-08-18

更改记录 Record of Modification

序号 No	更改日期 Date of modification	主要更改内容 Main content of modification	更改原因 Reason of modification	更改通知编号 Serial number of modification	确认 Confirm
1	2017-03-23		首版		覃达开
2	2017-04-01	1、增加产品图片	客户要求		覃达开
3	2017-04-29	1、修改 AC 模式 POWER 功率值	修正 power 标准		覃达开
4	2017-08-12	1、增加标签	产品增加认证号		覃达开
5	2017-8-18	增加 FCC NOTE	产品进行 FCC 认证		覃达开

1. Introduction

WIFI-2-R821USA1A is based on realtek RTL8821AU, is a WLAN 11ac module, which fully supports the features and functional compliance of IEEE 802.11 a/b/g/n/ac standards. This documentation describes the engineering requirements specification.

1.1 RF module Overview

The general HW architecture for the module is shown in Figure 1. This WLAN Module design is based on Realtek RTL8821AU. It is a highly integrated single-chip SISO(Single In Single Out) Wireless LAN (WLAN) USB2.0 network interface controller complying with the 802.11ac specification. It combines a MAC, a 1T1R capable baseband, and RF in a single chip. The RTL8821AU provides a complete solution for a high throughput performance wireless client.

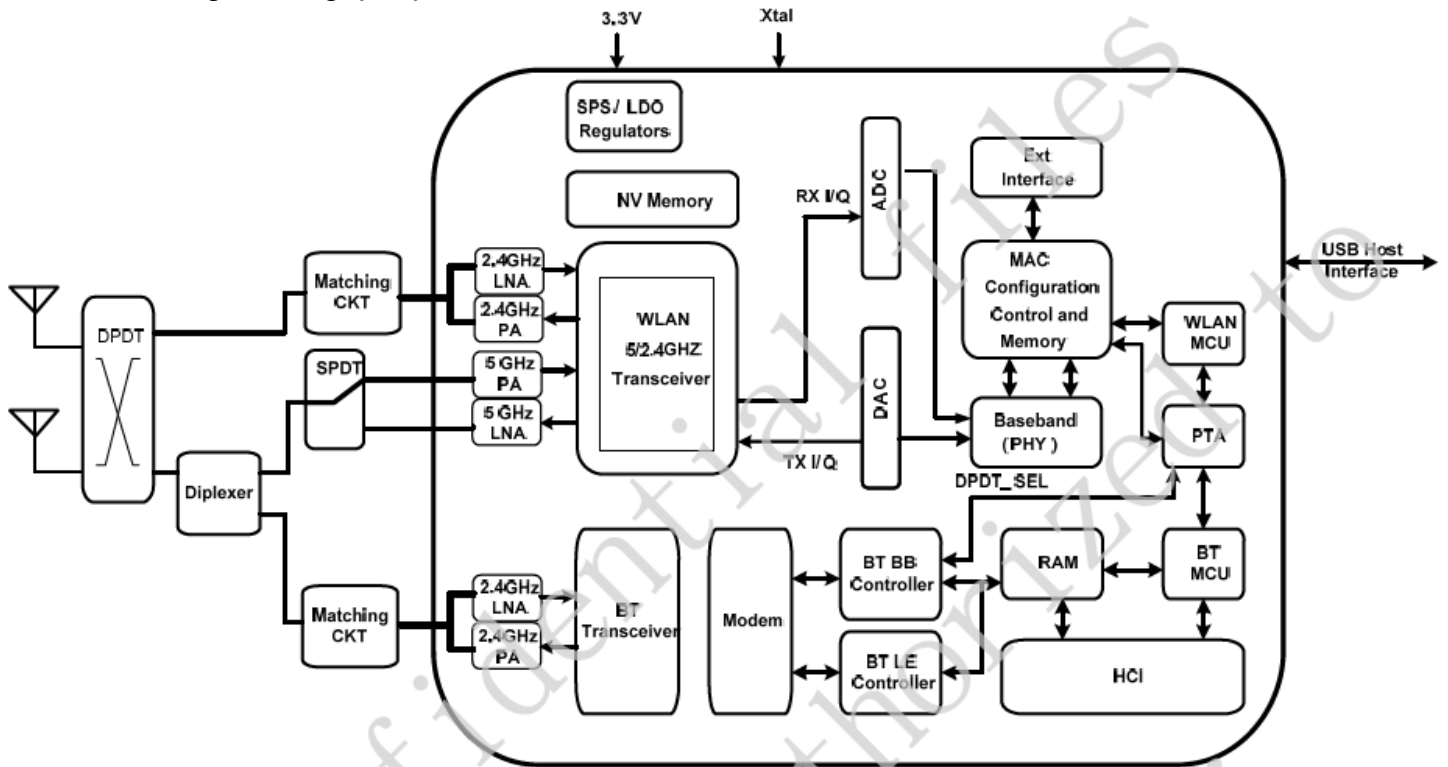

Figure 1 Module Block Diagram

1.2 Specification reference

This specification is based on additional references listed below.

- _ IEEE Std. 802.11a
- _ IEEE Std. 802.11b
- _ IEEE Std. 802.11g
- _ IEEE Std. 802.11n
- _ IEEE Std. 802.11ac
- _ Bluetooth 2.1/3.0/4.0

1.3 System Functions

Table1: General Specification as below:

Main Chipset	Realtek RTL8821AU-VS
Operating Frequency	2.412~2.472GHz & 5.18 -5.825 GHz
Wi-Fi Standard	802.11a/b/g/n (1x1)
Bluetooth	2.1/3.0/4.0
Modulation	WIFI: 11b: DBPSK, DQPSK and CCK and DSSS 11a/g: BPSK, QPSK, 16QAM, 64QAM and OFDM 11n: BPSK, QPSK, 16QAM, 64QAM and OFDM 11ac: BPSK, QPSK, 16QAM, 64QAM, 256QAM and OFDM BT: FHSS,GFSK,DPSK,DQPSK
Data rates	WIFI: 802.11b:11/5.5/2/1 Mbps 802.11g:54/48/36/24/18/12/9/6 Mbps 802.11n:up to 300Mbps 802.11ac:up to 433.5Mbps BT: 1M/2M/3M
Host Interface	USB 2.0
PCB Stack	4-layers design
Dimension	Typical, 19.00mm(L)*17.00mm(W) *2.60mm(H)
Operation Temperature	0°C to +60°C
Storage Temperature	-25°C to +85°C
Operation Voltage	3.3V +/-10%,350mA

2. Mechanical Specification

2.1 Mechanical Outline Drawing

Typical Dimension (L x W): 19.00mm x 17.00mm x 2.60mm

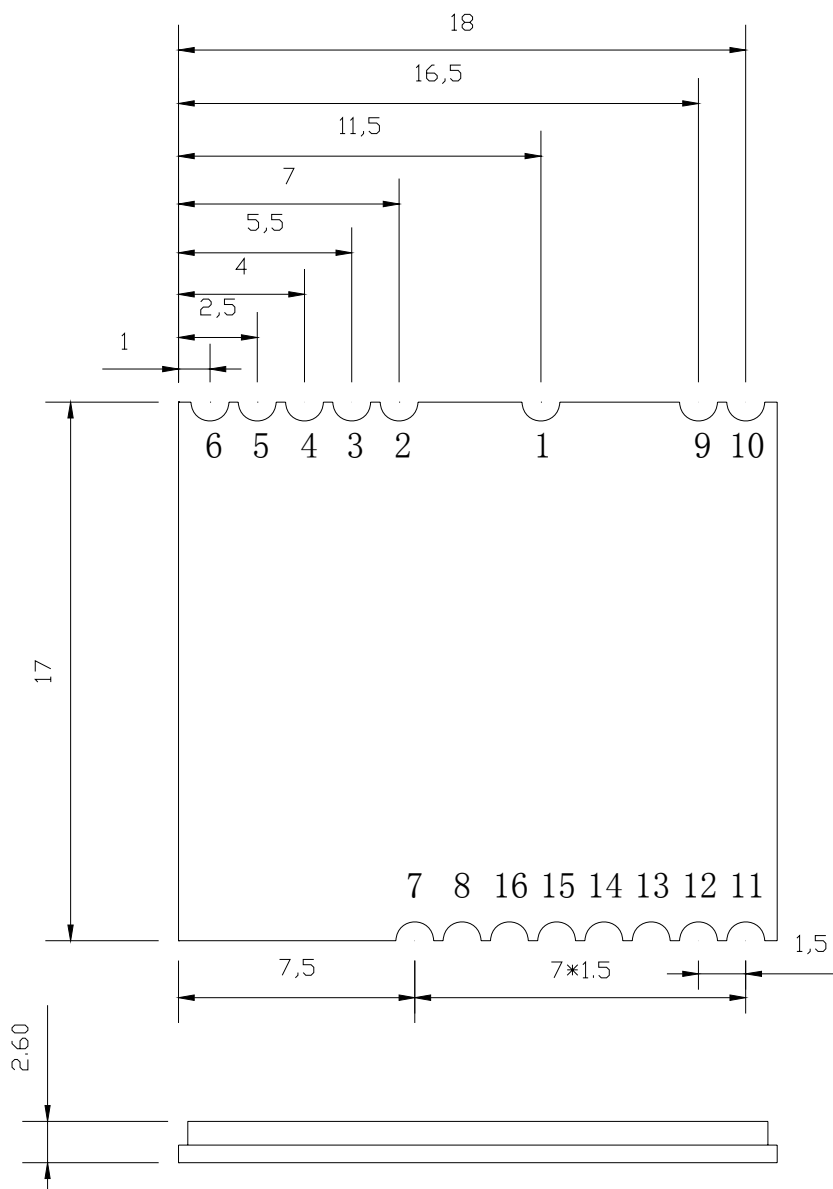

Pin definition

PIN	Type
1	LED0
2	AGND
3	MAIN
4	AGND
5	AUX
6	AGND
7	BT_DIS
8	WL_DIS
9	VDD33
10	AGND
11	HSDM
12	HSDP
13	AGND
14	Pdn
15	DEV_WAKE_HOST
16	HOST_WAKE_DEV

NOTE1:General tolerance ± 0.15 mm
unless otherwise stated

NOTE2:Unit mm

3. Electrical Specification

This Specification is based-on conductive DVT testing result. The extreme condition include overall temperature (0°C,+25°C,+60°C) and overall voltage (4.5V,5V,5.5V).

3.1 IEEE 802.11a Section:

Items	Contents				
Specification	IEEE802.11a				
Mode	OFDM				
Channel	CH36 to CH165				
Data rate	6, 9, 12, 18, 24, 36, 48, 54Mbps				
TX Characteristics	Min.	Typ.	Max.	Unit	Remark
1. Power Levels					
1) 11dBm Target (For Each antenna port)	9	11	13	dBm	
2. Spectrum Mask @ Target Power					
1) at fc +/-11MHz	-	-	-20	dBr	
2) at fc +/-20MHz	-	-	-28	dBr	
3) at fc > +/-30MHz	-	-	-40	dBr	
3. Constellation Error(EVM) @ Target Power					
1) 6Mbps	-	-	-5	dB	
2) 9Mbps	-	-	-8	dB	
3) 12Mbps	-	-	-10	dB	
4) 18Mbps	-	-	-13	dB	
5) 24Mbps	-	-	-16	dB	
6) 36Mbps	-	-	-19	dB	
7) 48Mbps	-	-	-22	dB	
8) 54Mbps	-	-30	-25	dB	
4. Frequency Error	-20	-5	20	ppm	
RX Characteristics	Min.	Typ.	Max.	Unit	
5. Minimum Input Level Sensitivity(each chain)					
1) 6Mbps (PER \leq 10%)	-	-85	-82	dBm	
2) 9Mbps (PER \leq 10%)	-	-84	-81	dBm	
3) 12Mbps (PER \leq 10%)	-	-82	-79	dBm	
4) 18Mbps (PER \leq 10%)	-	-80	-77	dBm	
5) 24Mbps (PER \leq 10%)	-	-77	-74	dBm	
6) 36Mbps (PER \leq 10%)	-	-73	-70	dBm	
7) 48Mbps (PER \leq 10%)	-	-69	-66	dBm	
8) 54Mbps (PER \leq 10%)	-	-68	-65	dBm	
6. Maximum Input Level (PER \leq 10%)	-30	-	-	dBm	

3.2 IEEE 802.11b Section:

Items	Contents				
Specification	IEEE802.11b				
Mode	DSSS / CCK				
Channel	CH1 to CH13				
Data rate	1, 2, 5.5, 11Mbps				
TX Characteristics	Min.	Typ.	Max.	Unit	Remark
1. Power Levels(Calibrated)					
1) 16dBm Target	14	16	18	dBm	
2. Spectrum Mask @ Target Power					
1) fc +/-11MHz to +/-22MHz	-	-	-30	dBr	
2) fc > +/-22MHz	-	-	-50	dBr	
3. Constellation Error(EVM) @ Target Power					
1) 1Mbps	-	-	-10	dB	
2) 2Mbps	-	-	-10	dB	
3) 5.5Mbps	-	-	-10	dB	
4) 11Mbps	-	-20	-10	dB	
4. Frequency Error	-20	-	20	ppm	
RX Characteristics	Min.	Typ.	Max.	Unit	
5. Minimum Input Level Sensitivity(each chain)					
1) 1Mbps (FER \leq 8%)	-	-83	-76	dBm	
2) 2Mbps (FER \leq 8%)	-	-80	-76	dBm	
3) 5.5Mbps (FER \leq 8%)	-	-79	-76	dBm	
4) 11Mbps (FER \leq 8%)	-	-76	-76	dBm	
6. Maximum Input Level (FER \leq 8%)	-10	-	-	dBm	

3.3 IEEE 802.11g Section:

Items	Contents				
Specification	IEEE802.11g				
Mode	OFDM				
Channel	CH1 to CH13				
Data rate	6, 9, 12, 18, 24, 36, 48, 54Mbps				
TX Characteristics	Min.	Typ.	Max.	Unit	Remark
2. Power Levels					
1) 14dBm Target	12	14	16	dBm	
3. Spectrum Mask @ Target Power					
1) at fc +/-11MHz	-	-	-20	dBr	
2) at fc +/-20MHz	-	-	-28	dBr	
3) at fc > +/-30MHz	-	-	-40	dBr	
4. Constellation Error(EVM) @ Target Power					
1) 6Mbps	-	-	-5	dB	
2) 9Mbps	-	-	-8	dB	
3) 12Mbps	-	-	-10	dB	
4) 18Mbps	-	-	-13	dB	
5) 24Mbps	-	-	-16	dB	
6) 36Mbps	-	-	-19	dB	
7) 48Mbps	-	-	-22	dB	
8) 54Mbps	-	-30	-25	dB	
5. Frequency Error	-20	-	20	ppm	
RX Characteristics	Min.	Typ.	Max.	Unit	
6 Minimum Input Level Sensitivity					
1) 6Mbps (PER ≤ 10%)	-	-85	-80	dBm	
2) 9Mbps (PER ≤ 10%)	-	-84	-79	dBm	
3) 12Mbps (PER ≤ 10%)	-	-82	-77	dBm	
4) 18Mbps (PER ≤ 10%)	-	-80	-75	dBm	
5) 24Mbps (PER ≤ 10%)	-	-77	-72	dBm	
6) 36Mbps (PER ≤ 10%)	-	-73	-68	dBm	
7) 48Mbps (PER ≤ 10%)	-	-69	-64	dBm	
8) 54Mbps (PER ≤ 10%)	-	-68	-63	dBm	
6. Maximum Input Level (PER ≤ 10%)	-20	-	-	dBm	

3.4 IEEE 802.11n HT20 Section:

Items	Contents				
Specification	IEEE802.11n HT20 @ 2.4GHz				
Mode	OFDM				
Channel	CH1 to CH13				
Data rate (MCS index)	MCS0/1/2/3/4/5/6/7/8/9/10/11/12/13/14/15				
TX Characteristics	Min.	Typ.	Max.	Unit	Remark
1. Power Levels					
1) 13dBm Target	11	13	15	dBm	
2. Spectrum Mask @ Target Power					
1) at fc +/-11MHz	-	-	-20	dBr	
2) at fc +/-20MHz	-	-	-28	dBr	
3) at fc > +/-30MHz	-	-	-45	dBr	
3. Constellation Error(EVM) @ Target Power					
1) MCS0	-	-	-5	dB	
2) MCS1	-	-	-10	dB	
3) MCS2	-	-	-13	dB	
4) MCS3	-	-	-16	dB	
5) MCS4	-	-	-19	dB	
6) MCS5	-	-	-22	dB	
7) MCS6	-	-	-25	dB	
8) MCS7	-	-31	-28	dB	
4. Frequency Error	-20	-	20	ppm	
RX Characteristics	Min.	Typ.	Max.	Unit	
5. Minimum Input Level Sensitivity					
1) MCS0 (PER \leq 10%)	-	-85	-82	dBm	
2) MCS1 (PER \leq 10%)	-	-84	-79	dBm	
3) MCS2 (PER \leq 10%)	-	-82	-77	dBm	
4) MCS3 (PER \leq 10%)	-	-80	-74	dBm	
5) MCS4 (PER \leq 10%)	-	-76	-70	dBm	
6) MCS5 (PER \leq 10%)	-	-72	-66	dBm	
7) MCS6 (PER \leq 10%)	-	-70	-65	dBm	
8) MCS7 (PER \leq 10%)	-	-69	-64	dBm	
6. Maximum Input Level (PER \leq 10%)	-20	-	-	dBm	

3.5 IEEE 802.11n HT20 Section:

Items	Contents				
Specification	IEEE802.11n HT20 @ 5GHz				
Mode	OFDM				
Channel	CH36 to CH165				
Data rate (MCS index)	MCS0/1/2/3/4/5/6/7/8/9/10/11/12/13/14/15				
TX Characteristics	Min.	Typ.	Max.	Unit	Remark
1. Power Levels					
1) 10dBm Target	8	10	12	dBm	
2. Spectrum Mask @ Target Power					
1) at fc +/-11MHz	-	-	-20	dBr	
2) at fc +/-20MHz	-	-	-28	dBr	
3) at fc > +/-30MHz	-	-	-45	dBr	
3. Constellation Error(EVM) @ Target Power					
1) MCS0	-	-	-5	dB	
2) MCS1	-	-	-10	dB	
3) MCS2	-	-	-13	dB	
4) MCS3	-	-	-16	dB	
5) MCS4	-	-	-19	dB	
6) MCS5	-	-	-22	dB	
7) MCS6	-	-	-25	dB	
8) MCS7	-	-31	-28	dB	
4. Frequency Error	-20	-	20	ppm	
RX Characteristics	Min.	Typ.	Max.	Unit	
5. Minimum Input Level Sensitivity					
1) MCS0 (PER \leq 10%)	-	-85	-82	dBm	
2) MCS1 (PER \leq 10%)	-	-84	-79	dBm	
3) MCS2 (PER \leq 10%)	-	-82	-77	dBm	
4) MCS3 (PER \leq 10%)	-	-80	-74	dBm	
5) MCS4 (PER \leq 10%)	-	-76	-70	dBm	
6) MCS5 (PER \leq 10%)	-	-72	-66	dBm	
7) MCS6 (PER \leq 10%)	-	-70	-65	dBm	
8) MCS7 (PER \leq 10%)	-	-69	-64	dBm	
6. Maximum Input Level (PER \leq 10%)	-30	-	-	dBm	

3.6 IEEE 802.11n HT40 Section:

Items	Contents				
Specification	IEEE802.11n HT40 @ 2.4GHz				
Mode	OFDM				
Channel	CH3 to CH11				
Data rate (MCS index)	MCS0/1/2/3/4/5/6/7/8/9/10/11/12/13/14/15				
TX Characteristics	Min.	Typ.	Max.	Unit	Remark
1. Power Levels					
1) 13dBm Target	11	13	15	dBm	
2. Spectrum Mask @ Target Power					
1) at fc +/-21MHz	-	-	-20	dBr	
2) at fc +/-40MHz	-	-	-28	dBr	
3) at fc > +/-60MHz	-	-	-45	dBr	
3. Constellation Error(EVM) @ Target Power					
1) MCS0	-	-	-5	dB	
2) MCS1	-	-	-10	dB	
3) MCS2	-	-	-13	dB	
4) MCS3	-	-	-16	dB	
5) MCS4	-	-	-19	dB	
6) MCS5	-	-	-22	dB	
7) MCS6	-	-	-25	dB	
8) MCS7	-	-31	-28	dB	
4. Frequency Error	-20	-	20	ppm	
RX Characteristics	Min.	Typ.	Max.	Unit	
5. Minimum Input Level Sensitivity					
1) MCS0 (PER \leq 10%)		-85	-79	dBm	
2) MCS1 (PER \leq 10%)		-82	-76	dBm	
3) MCS2 (PER \leq 10%)		-79	-74	dBm	
4) MCS3 (PER \leq 10%)		-77	-71	dBm	
5) MCS4 (PER \leq 10%)		-72	-67	dBm	
6) MCS5 (PER \leq 10%)		-69	-63	dBm	
7) MCS6 (PER \leq 10%)		-68	-62	dBm	
8) MCS7 (PER \leq 10%)	-	-66	-61	dBm	
6. Maximum Input Level(PER \leq 10%)	-20	-	-	dBm	

3.7 EEE 802.11n HT40 Section:

Items	Contents				
Specification	IEEE802.11n HT40 @ 5GHz				
Mode	OFDM				
Channel	CH38 to CH163				
Data rate (MCS index)	MCS0/1/2/3/4/5/6/7/8/9/10/11/12/13/14/15				
TX Characteristics	Min.	Typ.	Max.	Unit	Remark
1. Power Levels					
1) 10dBm Target	8	10	12	dBm	
2. Spectrum Mask @ Target Power					
1) at fc +/-21MHz	-	-	-20	dBr	
2) at fc +/-40MHz	-	-	-28	dBr	
3) at fc > +/-60MHz	-	-	-45	dBr	
3. Constellation Error(EVM) @ Target Power					
1) MCS0	-	-	-5	dB	
2) MCS1	-	-	-10	dB	
3) MCS2	-	-	-13	dB	
4) MCS3	-	-	-16	dB	
5) MCS4	-	-	-19	dB	
6) MCS5	-	-	-22	dB	
7) MCS6	-	-	-25	dB	
8) MCS7	-	-31	-28	dB	
4. Frequency Error	-20	-	20	ppm	
RX Characteristics	Min.	Typ.	Max.	Unit	
5. Minimum Input Level Sensitivity					
1) MCS0 (PER \leq 10%)		-85	-79	dBm	
2) MCS1 (PER \leq 10%)		-82	-76	dBm	
3) MCS2 (PER \leq 10%)		-79	-74	dBm	
4) MCS3 (PER \leq 10%)		-77	-71	dBm	
5) MCS4 (PER \leq 10%)		-72	-67	dBm	
6) MCS5 (PER \leq 10%)		-69	-63	dBm	
7) MCS6 (PER \leq 10%)		-68	-62	dBm	
8) MCS7 (PER \leq 10%)	-	-66	-61	dBm	
6. Maximum Input Level(PER \leq 10%)	-30	-	-	dBm	

3.8 IEEE 802.11ac HT20 Section:

Items	Contents				
Specification	IEEE802.11ac HT20 @ 5GHz				
Mode	OFDM				
Channel	CH36 to CH165				
Data rate (MCS index)	Nss1 MCS0/1/2/3/4/5/6/7/8 Nss2 MCS0/1/2/3/4/5/6/7/8				
TX Characteristics	Min.	Typ.	Max.	Unit	Remark
1. Power Levels					
1)10dBm Target	8	10	12	dBm	*
2. Spectrum Mask @ Target Power					
1) at fc +/-11MHz	-	-	-20	dBr	
2) at fc +/-20MHz	-	-	-28	dBr	
3) at fc > +/-30MHz	-	-	-40	dBr	
3. Constellation Error(EVM) @ Target Power					
1) Nss1 MCS0	-	-	-5	dB	
2) Nss1 MCS1	-	-	-10	dB	
3) Nss1 MCS2	-	-	-13	dB	
4) Nss1 MCS3	-	-	-16	dB	
5) Nss1 MCS4	-	-	-19	dB	
6) Nss1 MCS5	-	-	-22	dB	
7) Nss1 MCS6	-	-	-25	dB	
8) Nss1 MCS7	-	-	-27	dB	
9) Nss1 MCS8	-	-34	-30	dB	
4. Frequency Error	-20	-	20	ppm	
RX Characteristics	Min.	Typ.	Max.	Unit	
5. Minimum Input Level Sensitivity					
1) Nss1 MCS0 (PER \leq 10%)	-	-85	-82	dBm	
2) Nss1 MCS1 (PER \leq 10%)	-	-82	-79	dBm	
3) Nss1 MCS2 (PER \leq 10%)	-	-80	-77	dBm	
4) Nss1 MCS3 (PER \leq 10%)	-	-77	-74	dBm	
5) Nss1 MCS4 (PER \leq 10%)	-	-73	-70	dBm	
6) Nss1 MCS5 (PER \leq 10%)	-	-69	-66	dBm	
7) Nss1 MCS6 (PER \leq 10%)	-	-68	-65	dBm	
8) Nss1 MCS7 (PER \leq 10%)	-	-67	-64	dBm	
9) Nss1 MCS8 (PER \leq 10%)	-	-62	-59	dBm	
6. Maximum Input Level (PER \leq 10%)	-30	-	-	dBm	

*power by rate off

3.9 IEEE 802.11ac HT40 Section:

Items	Contents				
Specification	IEEE802.11ac HT40 @ 5GHz				
Mode	OFDM				
Channel	CH38 to CH159				
Data rate (MCS index)	Nss1 MCS0/1/2/3/4/5/6/7/8/9 Nss2 MCS0/1/2/3/4/5/6/7/8/9				
TX Characteristics	Min.	Typ.	Max.	Unit	Remark
1. Power Levels					
1) 10dBm Target	8	10	12	dBm	*
2. Spectrum Mask @ Target Power					
1) at fc +/-21MHz	-	-	-20	dBr	
2) at fc +/-40MHz	-	-	-28	dBr	
3) at fc > +/-60MHz	-	-	-40	dBr	
3. Constellation Error(EVM) @ Target Power					
1) Nss1 MCS0	-	-	-5	dB	
2) Nss1 MCS1	-	-	-10	dB	
3) Nss1 MCS2	-	-	-13	dB	
4) Nss1 MCS3	-	-	-16	dB	
5) Nss1 MCS4	-	-	-19	dB	
6) Nss1 MCS5	-	-	-22	dB	
7) Nss1 MCS6	-	-	-25	dB	
8) Nss1 MCS7	-	-	-27	dB	
9) Nss1 MCS8	-	-	-30	dB	
10) Nss1 MCS9	-	-35	-32	dB	
4. Frequency Error	-20	-	20	ppm	
RX Characteristics	Min.	Typ.	Max.	Unit	
5. Minimum Input Level Sensitivity					
1) Nss1 MCS0	-	-82	-79	dBm	
2) Nss1 MCS1	-	-79	-76	dBm	
3) Nss1 MCS2	-	-77	-74	dBm	
4) Nss1 MCS3	-	-74	-71	dBm	
5) Nss1 MCS4	-	-70	-67	dBm	
6) Nss1 MCS5	-	-66	-63	dBm	
7) Nss1 MCS6	-	-65	-62	dBm	
8) Nss1 MCS7	-	-64	-61	dBm	
9) Nss1 MCS8	-	-59	-56	dBm	
10) Nss1 MCS9	-	-57	-54	dBm	
6. Maximum Input Level (PER \leq 10%)	-30	-	-	dBm	

*power by rate off

3.10 IEEE 802.11ac HT80 Section:

Items	Contents				
Specification	IEEE802.11ac HT80 @ 5GHz				
Mode	OFDM				
Channel	CH42 to CH155				
Data rate (MCS index)	Nss1 MCS0/1/2/3/4/5/6/7/8/9 Nss2 MCS0/1/2/3/4/5/6/7/8/9				
TX Characteristics	Min.	Typ.	Max.	Unit	Remark
1. Power Levels					
1) 10dBm Target	8	10	12	dBm	*
2. Spectrum Mask @ Target Power					
1) at fc +/-41MHz	-	-	-20	dBr	
2) at fc +/-80MHz	-	-	-28	dBr	
3) at fc > +/-120MHz	-	-	-40	dBr	
3. Constellation Error(EVM) @ Target Power					
1) Nss1 MCS0	-	-	-5	dB	
2) Nss1 MCS1	-	-	-10	dB	
3) Nss1 MCS2	-	-	-13	dB	
4) Nss1 MCS3	-	-	-16	dB	
5) Nss1 MCS4	-	-	-19	dB	
6) Nss1 MCS5	-	-	-22	dB	
7) Nss1 MCS6	-	-	-25	dB	
8) Nss1 MCS7	-	-	-27	dB	
9) Nss1 MCS8	-	-	-30	dB	
10) Nss1 MCS9	-	-35	-32	dB	
4. Frequency Error	-20	-	20	ppm	
RX Characteristics	Min.	Typ.	Max.	Unit	
5. Minimum Input Level Sensitivity					
1) Nss1 MCS0	-	-79	-76	dBm	
2) Nss1 MCS1	-	-76	-73	dBm	
3) Nss1 MCS2	-	-74	-71	dBm	
4) Nss1 MCS3	-	-71	-68	dBm	
5) Nss1 MCS4	-	-67	-64	dBm	
6) Nss1 MCS5	-	-63	-60	dBm	
7) Nss1 MCS6	-	-62	-59	dBm	
8) Nss1 MCS7	-	-61	-58	dBm	
9) Nss1 MCS8	-	-56	-53	dBm	
10) Nss1 MCS9	-	-54	-51	dBm	
6. Maximum Input Level (PER \leq 10%)	-30	-	-	dBm	

*power by rate off

3.11 Bluetooth Section:

Items	Contents				
Specification	BT2.1/3.0/4.0				
Mode	FHSS,GFSK,DPSK,DQPSK				
Number of Channel	78 Channels				
Frequency Band	2.402 GHz ~2.480GHz				
	Min.	Typ.	Max.	Unit	Remark
1. Output Power	-6		20	dBm	
2. Gain step	2	4	8	dB	
3. Receiver sensitivity (BER \leq 0.1%)	-	-89	-85	dBm	
4. Maximum usable signal (BER \leq 0.1%)	-15	-6	-		
5. C/I co-channel (BER<0.1%)	-	10	11	dB	
6. C/I 1MHz (BER<0.1%)	-	-16	0	dB	
7. C/I 2MHz (BER<0.1%)	-	-41	-30	dB	
8. C/I \geq 3MHz (BER<0.1%)	-	-50	-40	dB	
9. C/I Image channel (BER<0.1%)	-	-24	-9	dB	
10. C/I Image 1MHz (BER<0.1%)	-	-35	-20	dB	
11. Inter-modulation	-	-13	-	dB	
12. Out-of-band blocking					
1). 30MHz to 2000MHz	-8	-	-	dBm	
2). 2000MHz to 2400MHz	-25	-	-	dBm	
3). 2500MHz to 3000MHz	-25	-	-	dBm	
4). 3000MHz to 12.75GHz	-8	-	-	dBm	
13. Modulation characteristics					
1). Δf_{1avg}	140	170	175	KHz	
2). Δf_{2max} (For at least 99.9% of all Δf_{2max})	115	145	-	KHz	
3). $\Delta f_{2avg} / \Delta f_{1avg}$	0.8	0.84	-	KHz	
14. ICFT	-75	± 8.0	+75	KHz	
15. Carrier frequency drift					
1). One slot packet (DH1)	-25	- 13	+25	KHz	
2). Two slot packet (DH3)	-40	- 12	+40	KHz	
3). Five slot packet (DH5)	-40	- 12	+40	KHz	
4). Max drift rate	-	5.853	20	KHz/50us	
16. TX output spectrum(20dB bandwidth)	-	796	1000	KHz	
17. In-Band spurious emission					
1). ± 2 MHz offset	-	-39	-20	dBm	
2). ± 3 MHz offset	-	-50	-40	dBm	
3). $> \pm 3$ MHz offset	-	-50	-40	dBm	

4 Antenna matching

The 3th Pin and 5th Pin connect to antenna, please refer to design demand

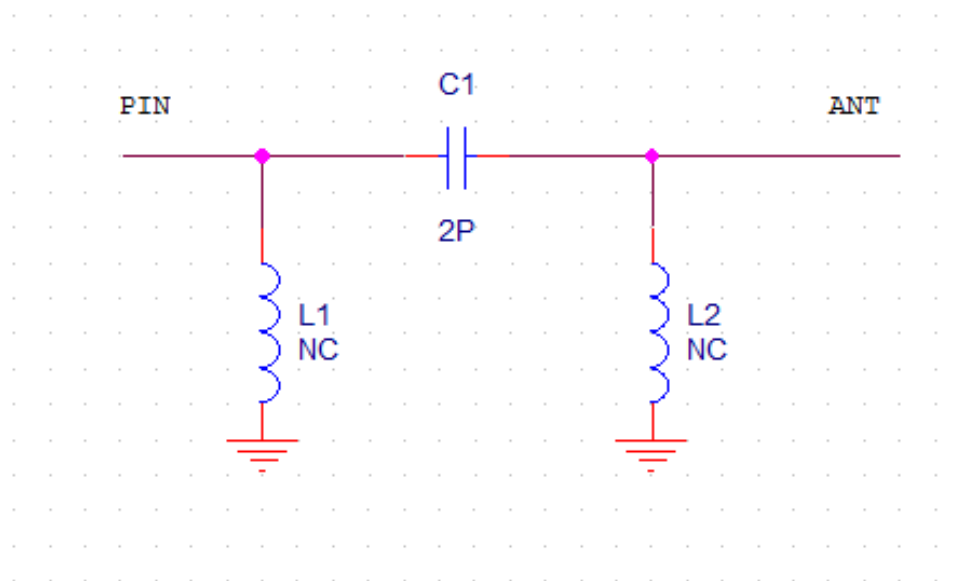

- 模块和天线要求远离干扰源，模块地和天线地要求为一个整体。
- PIN6为WIFI模组的RF接口，与天线之间布线要求共面阻抗为 $50\ \Omega$ ，建议使用弧线和直线，长度尽可能短。
- L1, L2, C1组成 π 型匹配网络并靠近天线接口设计，具体根据天线推荐及排版设计的实测效果进行调整。

5. Package Information

外箱标签粘贴位置及示意图

四川爱联科技有限公司 [RoHs]
V. C:
P/N:
Cvte. Des:
D. C:
LOT NO:
Q' TY:
V. DES:
G. W (kg):

1

N. W (kg): 3.8
C. SIZE (mm): 378*297*370

小箱标签粘贴位置及示意图

四川爱联科技有限公司 [RoHs]
V. C:
P/N:
Cvte. Des:
D. C:
LOT NO:
Q' TY:
V. DES:

1

包装说明:

- 1.每卷放900只产品，每小箱放1卷，大箱共5个小箱，产品数量共4500只/箱;
- 2.外箱尺寸：375mm*300mm*370mm，小箱尺寸：355mm*355mm*55mm;
- 3.最小包装、外箱、尾箱用同款标签纸打印;
- 4.真空包内放置2g干燥剂2袋，6色湿度卡1张。

6、Refelw Standard Condition

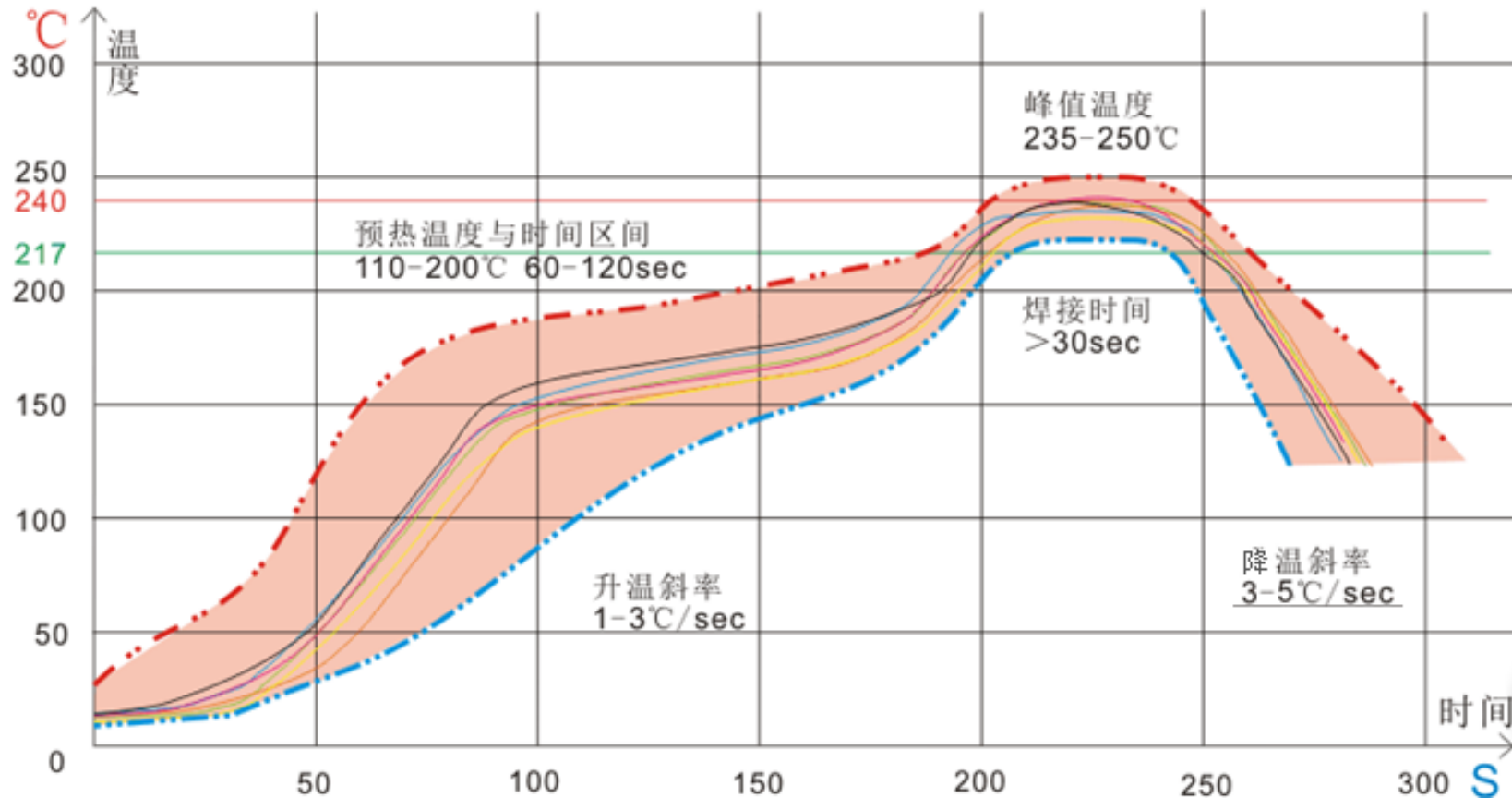

升温区：温度：<150°C，时间：60~90秒之间，斜率控制在1~3°C/S之间。

预热恒温区：温度：150°C~200°C，时间：60-120秒之间，斜率在0.3-0.8之间。

回流焊接区：峰值温度235°C~250°C(建议峰值温度<245°C)，时间30-70秒。

冷却区：温度：217°C~170°C，斜率在3~5°C/S之间。

焊料为锡银铜合金无铅焊料/ Sn&Ag&Cu Lead-free solder(SAC305)。

注意：产品可承受极限温度255度5秒，为保证产品质量，回流曲线应该在保证焊点质量时不损害PCB和元器件之间寻求平衡，并在以上曲线区间内进行为宜。

7、Product Picture



TOP VIEW

BOTTOM VIEW

产品丝印说明如下：

- 1、第一行“94V-0”为阻燃标志。
- 2、第二行“S”为PCB供应商代码。
- 3、第二行“Y16M12D21”为PCB生产批次信息，会稍有不同。
- 4、第三行“JUB7.820.1321-2”为我司产品图号。

FCC Statement

This device complies with part 15 of the FCC rules. Operation is subject to the following two conditions:

(1) this device may not cause harmful interference, and (2) this device must accept any interference received, including interference that may cause undesired operation.

Changes or modifications not expressly approved by the party responsible for compliance could void the user's authority to operate the equipment.

NOTE: This equipment has been tested and found to comply with the limits for a Class B digital device, pursuant to part 15 of the FCC Rules. These limits are designed to provide reasonable protection against harmful interference in a residential installation. This equipment generates uses and can radiate radio frequency energy and, if not installed and used in accordance with the instructions, may cause harmful interference to radio communications. However, there is no guarantee that interference will not occur in a particular installation. If this equipment does cause harmful interference to radio or television reception, which can be determined by turning the equipment off and on, the user is encouraged to try to correct the interference by one or more of the following measures:

- Reorient or relocate the receiving antenna.
- Reorient or relocate the receiving antenna.
- Reorient or relocate the receiving antenna.
- Consult the dealer or an experienced radio/TV technician for help important announcement

Important Note:

Radiation Exposure Statement

This equipment complies with FCC radiation exposure limits set forth for an uncontrolled environment. This equipment should be installed and operated with minimum distance 20cm between the radiator and your body.

This transmitter must not be co-located or operating in conjunction with any other antenna or transmitter.

Country Code selection feature to be disabled for products marketed to the US/Canada.

This device is intended only for OEM integrators under the following conditions:

1. The antenna must be installed such that 20 cm is maintained between the antenna and users, and
2. The transmitter module may not be co-located with any other transmitter or antenna,

Important Note:

In the event that these conditions cannot be met (for example certain laptop configurations or co-location with another transmitter), then the FCC authorization is no longer considered valid and the FCC ID cannot be used on the final product. In these circumstances, the OEM integrator will be responsible for re-evaluating the end product (including the transmitter) and obtaining a separate FCC authorization.

Any company of the host device which install this modular with limit modular approval should perform the test of radiated emission and spurious emission according to FCC part 15C:15.247 and 15.209 requirement, Only if the test result comply with FCC part 15.247 and 15.209 requirement, then the host can be sold legally.

End Product Labeling

If the FCC identification number is not visible when the module is installed inside another device, then the outside of the device into which the module is installed must also display a label referring to the enclosed module. This exterior label can use wording such as the following: Contains Transmitter Module FCC ID: 2AFG6-R821USA1A.

Manual Information to the End User

The OEM integrator has to be aware not to provide information to the end user regarding how to install or remove this RF module in the user's manual of the end product which integrates this module.

The end user manual shall include all required regulatory information/warning as show in this manual.

When the module is installed inside another device, the user manual of this device must contain below warning statements;

1. This device complies with Part 15 of the FCC Rules. Operation is subject to the following two conditions:
 - (1) This device may not cause harmful interference.
 - (2) This device must accept any interference received, including interference that may cause undesired operation.

Changes or modifications not expressly approved by the party responsible for compliance could void the user's authority to operate the equipment. The devices must be installed and used in strict accordance with the manufacturer's instructions as described in the user documentation that comes with the product.