

# **E-Kanban Call Button**

## ***Installation and Configuration Guide***

07-00090-001



---

# Contents

<b>About the E-Kanban Call Button .....</b>	<b>2</b>
<b>Powering the E-Kanban Call Button .....</b>	<b>3</b>
Battery Power .....	3
12VDC Central Supply Power .....	4
<b>Mounting the E-Kanban Call Button.....</b>	<b>5</b>

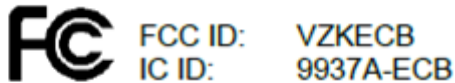

This device complies with Part 15 of the FCC Rules. Operation is subject to the following two conditions:

- (1) This device may not cause harmful interference, and
- (2) this device must accept any interference received, including interference that may cause undesired operation.

NOTE: THE GRANTEE IS NOT RESPONSIBLE FOR ANY CHANGES OR MODIFICATIONS NOT EXPRESSLY APPROVED BY THE PARTY RESPONSIBLE FOR COMPLIANCE. SUCH MODIFICATIONS COULD VOID THE USER'S AUTHORITY TO OPERATE THE EQUIPMENT.

This device complies with Industry Canada's license-exempt RSSs. Operation is subject to the following two conditions:

- (1) This device may not cause interference, and
- (2) This device must accept any interference, including interference that may cause undesired operation of the device.

Le présent appareil est conforme aux CNR d'Industrie Canada applicables aux appareils radio exempts de licence. L'exploitation est autorisée aux deux conditions suivantes :

- (1) l'appareil ne doit pas produire de brouillage, et
- (2) l'utilisateur de l'appareil doit accepter tout brouillage radioélectrique subi, même si le brouillage est susceptible d'en compromettre le fonctionnement.

## About the E-Kanban Call Button

The E-Kanban Call Button (ECB) is a call button intended for just-in-time parts replenishment to assembly lines in manufacturing operations (e-Kanban). Its true wireless nature enables easy deployment without need for wired power or communication lines. Alternately, a hard-wired power supply can be used if desired.

The ECB has a large multi-color LED indicator which is constructed in such a way that it can be observed from a distance in the well-lit environments characteristic of a production line.

Two large buttons enable workers to call for parts, and their robust construction allows for rough handling without fear of damage. Button functions are software configurable.

The ECB communicates to the rest of GuardRFID system utilizing the same infrastructure as GuardRFID tags, and communication frequency used (433 MHz), ensures reliable 2-way communication in the most difficult RF conditions. A variety of LED flashing patterns, colors and buzzer annunciations enable the device to signal a wide spectrum of notifications, under full control of software application.

- Rugged construction suitable for harsh environments
- Powered by battery or 12VDC power supply
- 12 months battery life – Replaceable batteries
- 2-way communication for sending requests and receiving audio-visual commands
- Two configurable buttons for custom functions
- Large multi-color LED indicator and buzzer
- Splash-resistant



# Powering the E-Kanban Call Button

You can supply power to the E-Kanban Call Button in two ways:

- The device can be powered by four AA batteries.
- The device can be connected to a +12VDC power source via its mini CT connector.

GuardRFID recommends that you use both power sources—if the device has access to both battery power and wired power, the batteries act as a back-up in case the central power supply fails.

Both the battery compartment and power connector are on the back of the E-Kanban Call Button, which is typically inaccessible once the device is mounted. Install power sources before mounting the device.

## Battery Power

You can supply power to the E-Kanban Call Button using four AA batteries, which will provide about 12 months of operating power. Battery life varies according on usage frequency.

Note that if the device is powered by both 12VDC wired power and batteries, it uses the wired power in preference.

### Inserting batteries into the E-Kanban Call Button

1. Using a Phillips screwdriver, remove the three screws on the back of the device. Remove the battery cover to expose the battery compartment.
2. Insert four fresh AA batteries into the compartment, taking care to orient them according to the diagram embossed into the compartment's surface.
3. Replace the battery cover and secure it in place using the screws.



## 12VDC Central Supply Power

You can supply power to the E-Kanban Call Button through a 2-pin mini CT connector accessible through the back of the device. The device requires +12VDC, and should not draw more than 35mA current during normal operation.

Note that if the device is powered by both 12VDC wired power and batteries, it uses the wired power in preference.

### Wiring and connector specifications

- The E-Kanban Call Button's mini CT connector is 2-pin, 2 position, 1.5mm pitch header connector (Digikey part number A98681-ND). It accepts a 1.5mm pitch female socket receptacle such as Digikey part number A100192-ND.
- The power wire should be 18AWG or thicker.

### Connecting the E-Kanban Call Button to 12VDC power

1. Wire a 2-pin socket receptacle to your 12VDC power source. Be sure to observe the polarity of the connector (see the diagram below).

2. Using a coin or similar small, flat object, twist the circular port cover on the back of the E-Kanban Call Button counter-clockwise  $\frac{1}{4}$  turn to unlock it. Remove the cover.

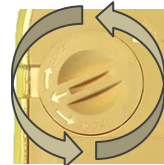

3. Plug the socket receptacle into the 2-pin connector. Lay the wires in the cable trough (see the diagram below).

4. Line up the arrow on the circular port cover to the **OPEN** arrow on the back of the device, then press it into place. Provided the wires are thin, the port cover should fit into place

5. Turn the port cover clockwise  $\frac{1}{4}$  turn to lock it.

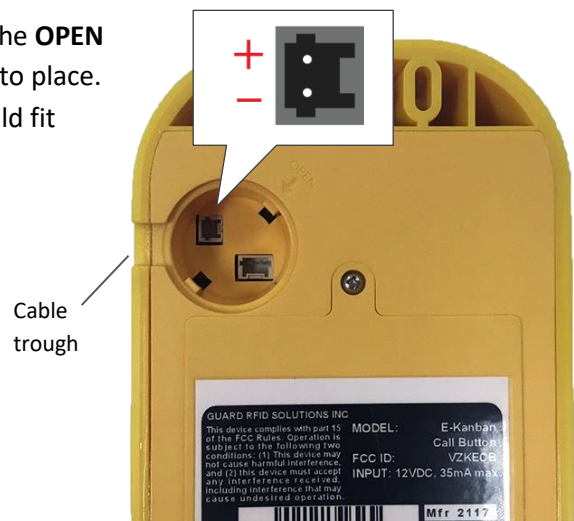

# Mounting the E-Kanban Call Button

The E-Kanban Call Button is a robust device designed for industrial environments, and can be mounted to a hard surface or left unmounted for portability (although this latter option will make wired power difficult).

Note that mounting the device usually makes it difficult to access the back of the device. Be sure to insert batteries/wire the device to power, and to record the device's serial number, before mounting it.

## Bolts or screws

The E-Kanban Call Button can be mounted to a solid surface using screws or bolts. Thread the bolts through the holes at either end of the device. Note that you will have to unfasten the device to access the battery compartment or connectors.

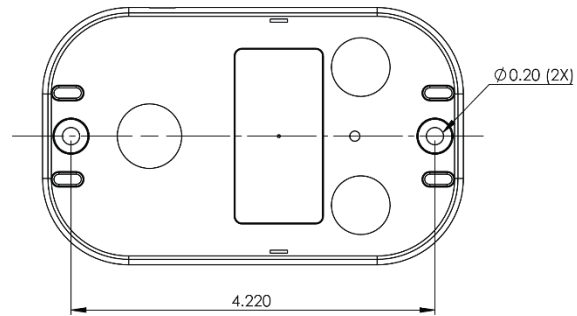

## Tie wraps

The E-Kanban Call Button can be mounted to a post or grate using tie wraps. Thread the tie wraps through the slots at either end of the device. Note that you will have to cut the tie wraps to access the battery compartment or connectors.

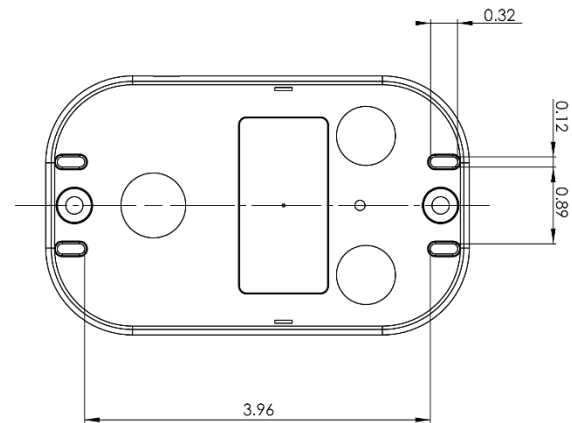

## Adhesives

You can mount the E-Kanban Call Button to a surface using double-sided adhesive pads, but this is not typically recommended. Although adhesive pads will not damage the device and can provide secure mounting, they are also more difficult to remove than fasteners and may obscure the device serial number label. Use this method only if you do not need to regularly access the back of the device (i.e., if you are primarily using wired power).