



# BP-10-27 MACHINE MANUAL

**BLASTPRO MANUFACTURING, INC. ~ WARRANTY & REGISTRATION CARD**  
**ONE YEAR LIMITED WARRANTY**  
(1-877-495-6464)

**A COPY OF THE WARRANTY CARD ON THE FOLLOWING PAGE, TOGETHER WITH PROOF OF PAYMENT, MUST BE SUBMITTED WITH ANY SERVICE REQUEST. THIS WARRANTY CARD MUST BE RETURNED TO: BLASTPRO MANUFACTURING, INC., 6021 MELROSE LANE, OKLAHOMA CITY, OK 73127, WITHIN TEN (10) DAYS OF ACQUIRING BLASTPRO PRODUCTS IN ORDER TO QUALIFY FOR THE ONE YEAR LIMITED WARRANTY CONTAINED IN THE SALES AGREEMENT.**

---

BlastPro provides as a limited warranty to Original Purchasers of BlastPro equipment, purchased within and situated within the United States of America, who notify BlastPro in writing through completion of the BlastPro Equipment Warranty Card within ten (10) days of acquiring BlastPro Equipment, the following limited warranty.

Subject to the exclusions, limitations and conditions stated above and below, BlastPro will warrant its products against defects in materials and workmanship, provided the Original Purchaser uses such equipment under normal and proper use, for a period of one year or 1,000 hours, whichever occurs first, from the date of delivery to the Original Purchaser.

During the applicable limited warranty period and subject to the exclusions, limitations and conditions contained herein, BlastPro shall, within a reasonable period of time, repair or replace, at its option, any defective components of the equipment. The limited warranty does not cover wear parts, including but not limited to, tires, magnets, seals, casters, liners, wear plates, bearings, cages, blast wheels, blades, belts, electrical wiring components and items of a similar nature.

This limited warranty does not cover damage to BlastPro equipment caused by any of the following: the use of the equipment for purposes other than which the equipment was designed and intended, all external causes such as (without limitation) acts of God, accidents, dropping, collision, fire, water damage, freezing, striking other objects, misuse or otherwise using the equipment contrary to the instructions and warnings contained in the User Manual; altering or modifying BlastPro equipment or accessories; exposure to environmental conditions beyond reasonable limits and the limits stated in the equipment manual; failure to properly maintain and service the equipment; damage caused by the use of any non-BlastPro parts or attachments on the equipment.

To obtain repair or replacement under this limited warranty, the Original Purchaser must contact BlastPro at 1-877-495-6464. The Original Purchaser must be prepared to describe any alleged problem, as well as provide proof of purchase and proof of date of delivery and return of the Equipment Warranty Card. Written authorization from BlastPro must be obtained prior to any BlastPro equipment being returned to BlastPro.

Once BlastPro provides the Original Purchaser with a written authorization, then the Original Purchaser shall deliver the equipment as instructed by BlastPro. The Original Purchaser shall pay the cost of shipping and shall also bear any risk of loss during shipping. Providing the BlastPro equipment is defective and the limited warranty applies, BlastPro shall, within a reasonable period of time, repair or replace any defective components. The Original Purchaser shall be responsible for picking up the repaired equipment or may arrange for shipment at Original Purchaser's expense.

BlastPro's repair or replacement of any defective parts on the equipment does not extend the term of this limited warranty, which shall expire on expiration of the period of one year from the date of Original delivery, subject to the further terms of this warranty.

---

**THIS LIMITED WARRANTY IS THE ONLY WARRANTY APPLICABLE TO BLASTPRO EQUIPMENT. BLASTPRO DISCLAIMS ALL OTHER WARRANTIES, EXPRESS OR IMPLIED, INCLUDING IMPLIED WARRANTIES OF MERCHANTABILITY OR FITNESS FOR A PARTICULAR PURPOSE, OTHER THAN THOSE WARRANTIES IMPLIED AND INCAPABLE OF EXCLUSION, RESTRICTION OR MODIFICATION UNDER APPLICABLE LAW. ANY SUCH IMPLIED WARRANTIES WHICH MAY BE REQUIRED BY LAW AND ARE NOT DISCLAIMED HEREBY, ARE LIMITED TO THE EXTENT ALLOWED BY LAW TO THE APPLICABLE PERIOD OF THIS IMPLIED WARRANTY OR TO THE APPLICABLE TIME PERIOD PROVIDED BY THE APPLICABLE STATE LAW, WHICHEVER PERIOD IS SHORTER.**

**UNDER NO CIRCUMSTANCES SHALL BLASTPRO BE LIABLE TO THE ORIGINAL PURCHASER OR ANY OTHER PERSON FOR ANY DIRECT, INDIRECT OR CONSEQUENTIAL DAMAGES RESULTING FROM THE USE OR MISUSE OF THE EQUIPMENT OR ARISING OUT OF ANY BREACH OF ANY WARRANTY OR FOR ANY SPECIAL OR CONSEQUENTIAL DAMAGES OF ANY CHARACTER, INCLUDING WITHOUT LIMITATION, DAMAGES FOR ANY LOSS OF GOODWILL, WORK STOPPAGE OR ANY AND ALL OTHER COMMERCIAL DAMAGES OR LOSSES.**

**NO CHANGE TO OR ADDITIONAL WARRANTY, NO MATTER BY WHOM MADE OR WHEN MADE, SHALL APPLY TO ANY EQUIPMENT SOLD BY BLASTPRO.**

**BlastPro Warranty Registration Card**

**NOTICE!**

To ensure the proper warranty coverage is extended to the owner of this machine, fill out the attached card **COMPLETELY** and **ACCURATELY** and return to BlasPro Mfg.

Keep this top portion for your records

**USER'S REFERENCE INFORMATION**

<b>Delivery Date</b> _____	<b>Machine Model No.</b> _____
<b>Delivering Distributors Name</b>	<b>Machine Serial No.</b> _____
<b>and Address</b> _____	<b>Modifications</b> _____
_____	_____
_____	_____
_____	_____
_____	_____

CUT HERE

**WARRANTY REGISTRATION CARD**

**IMPORTANT!** To ensure that your BlastPro machine is covered under warranty, please fill in the following information and mail it to BlastPro Manufacturing, Inc. 6021 Melrose Lane, Oklahoma City, OK 73127, or Fax to 405-495-1331

(All boxes must be checked or date filled in)

Operating Manual Received  Training Scheduled \_\_\_\_\_ Training Complete

(Please Print)

**Company** \_\_\_\_\_  
**Address** \_\_\_\_\_  
**City** \_\_\_\_\_ **State** \_\_\_\_\_ **Zip** \_\_\_\_\_  
**Phone Number** \_\_\_\_\_  
**Contact Person** \_\_\_\_\_  
**Purchase Date** \_\_\_\_\_ **Delivery Date** \_\_\_\_\_  
**Machine Model No.** \_\_\_\_\_  
**Distributor Name** \_\_\_\_\_



### SECTION 4.8: MAINTENANCE CHECK LIST

The items on the check list must be inspected before each operation. This will maximize production and minimize down time. Always place machine into "Maintenance Mode" prior carrying out any maintenance or repairs. See Machine Manual Section 2.2.



	Blast wheel	Check for balance and excessive wear.
	Blades	Check for excessive wear. Change blades as a kit.
	Top and Lower liner	Check for excessive wear; Change when ½ worn through.
	Pinch Bar	Check for proper clearance and excessive wear.
	Pinch Bar/Blade Gap	Gap should be approximately 1/8" – 3/16". Rotate pinch bar ¼ turn every 8 hours of operation.
	Blast Wheel Bearings	Check and tighten set screws as necessary. Apply 5 pumps of grease every 8-10 hours of operation <sup>2</sup> .
	Shot Valve	Check for shot leaks.
	Filters	Inspect filters for damage. Replace if clogged with dust. <b>DO NOT BANG FILTERS ON THE GROUND.</b>
	Engine Oil	Check level. Change oil every 100 hours <sup>1</sup> .
	Air Cleaner	Check for dirty, loose or damaged parts. Change every 100 hours <sup>1</sup> .
	Transmission Oil	Inspect transmission for leaks.
	Axle Seals	Inspect for leaks.
	Blast Housing seals	Inspect for excessive wear. Insure seals provide a solid seal around the blast housing.
	Blower Bearings	Check and tighten set screws as necessary. Apply 5 pumps of grease every 8-10 hours of operation <sup>2</sup> .
	Steering Assembly	Check chain tension. Check and tighten set screws as necessary. Apply 1 pump of grease to bearings every 40 hours of operation <sup>2</sup> .
	Belts	Check condition and tension. Re-tension as necessary and replace damaged belts.



	Idler Assembly	Check and tighten set screws as necessary. Apply 1 pump of grease to bearing every 40 hours. <sup>1</sup>
	Dust Collector Latches	Verify latches securely close the dust collector door. Adjust as necessary. Replace damaged latches.
	Air Compressor Oil <sup>2</sup>	Check level. Change at 20 hours (New comp. break in) Change at 40 hours (New comp. break in) Change every 100 hours (Following break in period). <sup>3</sup>
	Air Tank Water Drain	Drain water from the air tank.
	Other Engine Maintenance	See Engine "Owner's Manual" for additional maintenance points and schedule

1. Care should be taken not to over-grease bearings.  
Recommended: Mystik JT6 Hi-Temp multi-purpose grease.
2. Use only SAE 30, non-detergent, single-viscosity, compressor oil.
3. Perform maintenance interval more frequently under extremely dusty conditions.

## Maintenance Instructions

	 <b>WARNING</b>	<p>Before working on engine or equipment, disable engine as follows: 1) Disconnect spark plug lead(s). 2) Disconnect negative (-) battery cable from battery.</p>
	<p>Accidental Starts can cause severe injury or death.</p> <p>Disconnect and ground spark plug lead(s) before servicing.</p>	

Normal maintenance, replacement or repair of emission control devices and systems may be performed by any repair establishment or individual; however, warranty repairs must be performed by a Kohler authorized dealer found at KohlerEngines.com or 1-800-544-2444 (U.S. and Canada).

For safety and health reasons, many states require special licensing or certification for servicing propane fuel systems. Check local and state regulations before choosing a repair establishment to perform fuel system repairs.

## Maintenance Schedule

### Every 25 Hours<sup>1</sup>

- Service/replace low-profile precleaner (if equipped).

### Every 100 Hours<sup>1</sup>

- Check oil cooler fins, clean as necessary (if equipped).
- Change oil.
- Replace low-profile air cleaner element (if equipped).
- Remove cooling shrouds and clean cooling areas.

### Every 150 Hours<sup>1</sup>

- Check heavy-duty filter minder.
- Inspect heavy-duty air filter paper element and inlet screen area.

### Every 200 Hours<sup>1</sup>

- Change oil filter.
- Replace unique EFI fuel filters.

### Every 300 Hours<sup>1</sup>

- Replace heavy-duty air cleaner element and check inner element.

### Every 500 Hours or Annually<sup>1</sup>

- Check all lines (high pressure/vacuum) including fittings for leaks.
- Drain vaporizer/regulator of accumulated fuel deposits.
- Replace spark plugs and set gap.

### Every 500 Hours or Annually<sup>1,2</sup>

- Inspect lock-off assembly for damage/leakage.
- Have combustion deposits removed if using non-synthetic oil.

### Every 600 Hours or Annually<sup>1</sup>

- Replace heavy-duty air cleaner inner element.

### Every 1500 Hours<sup>1,2</sup>

- Have vaporizer/regulator tested.

<sup>1</sup> Perform these procedures more frequently under severe, dusty, dirty conditions.

<sup>2</sup> Must be performed by a Kohler authorized dealer or qualified propane personnel only.



MACHINE MANUAL  
TABLE OF CONTENTS

BP-10-27

<b>SECTION 1.1: APPLICATIONS</b> .....	4
<b>SECTION 1.2: SPECIFICATIONS</b> .....	4
<b>SECTION 1.3: MANUFACTURER</b> .....	5
<b>SECTION 2.1: GENERAL</b> .....	7
<b>SECTION 2.2: MAINTENANCE AND WEAR PARTS REPLACEMENT MODES</b> .....	7
<b>SECTION 2.3: WORK SITE ASSESSMENT AND INSPECTION</b> .....	8
<b>SECTION 2.4: PERSONAL PROTECTIVE EQUIPMENT</b> .....	11
<b>SECTION 2.5: OPERATIONAL</b> .....	11
<b>SECTION 3.1: START-UP</b> .....	14
FIGURE 3.1.1 .....	15
<b>SECTION 3.2: SHUT DOWN</b> .....	17
<b>SECTION 3.3: SHOT SELECTION</b> .....	18
<b>SECTION 3.4: TRANSPORT</b> .....	19
FIGURE 3.4.1 .....	19
<b>SECTION 4.1: WEAR BAR REMOVAL AND INSTALLATION</b> .....	21
FIGURE 4.1.1 .....	22
<b>SECTION 4.2: BLAST WHEEL REMOVAL AND INSTALLATION</b> .....	22
<b>SECTION 4.3: TOP LINER REMOVAL AND INSTALLATION</b> .....	23
<b>SECTION 4.4: BLADE REMOVAL AND INSTALLATION</b> .....	24
FIGURE 4.4.1 .....	25
<b>SECTION 4.5: DUST COLLECTOR FUNCTION AND MAINTENANCE</b> .....	25
<b>SECTION 4.6: PARTS LIST</b> .....	28
<b>SECTION 4.7: ELECTRICAL SCHEMATIC</b> .....	30
<b>SECTION 4.8: MAINTENANCE CHECK LIST</b> .....	31



MACHINE MANUAL  
SPECIFICATIONS

BP-10-27

SECTION 1.1: APPLICATIONS

SECTION 1.2: SPECIFICATIONS

SECTION 1.3: MANUFACTURER



### SECTION 1.1: APPLICATIONS

The BP-10-27 shot blast machine is specifically designed for horizontal applications. It is designed to simultaneously remove material, clean and profile the substrate.

The BP-10-27 shot blast machine runs on a Kohler 27 hp lp motor

When in operation, the machine continuously recycles shot so that up to 1,500 square feet of surface area can be cut per hour while achieving a brush blast. To accomplish this feat, the machine first moves shot from the shot valve into the blast wheel. After being thrown by the blast wheel onto the surface below the machine, the shot and the debris then rebound up to the dust separator where the dust is automatically transferred to the dust collector. Next, the shot returns to the shop hopper where it is once again passed through the machine. The BP-10-27 constantly recycles the shot from the time the shot valve is opened until the time when the shot valve is closed by the operator. While the machine is in operation, the auto pulse dust collector cleans all six cartridge filters.

### SECTION 1.2: SPECIFICATIONS

DIMENSIONS (L x W x H)	78" x 34" x 57" (1981.5mm x 863.5mm x 1448mm)
WEIGHT	1525 LBS (692 kg)
DRIVE MOTOR	27 hp Kohler
DUAL FUEL	LP
FUEL CAPACITY	33LB
BLASTING WIDTH	10"
ELECTRICAL SYSTEM	12 VDC
DUST COLLECTOR COMPRESSOR	90 PSI
DUST COLLECTOR FAN	2600 CFM
FRONT END LIFT	HYDRAULIC
SHOT VALVE	ELECTRIC
STEERING	MANUAL STEERING WHEEL



**SECTION 1.3: MANUFACTURER**

BlastPro Manufacturing, Inc.  
6021 Melrose Lane  
Oklahoma City, OK 73127  
Toll free: 877-495-6464  
Phone: 405-491-6464  
Fax: 405-495-4994  
Website: [www.BlastProMfg.com](http://www.BlastProMfg.com)



# DANGER



**Respirable crystalline silica**  
**May cause cancer**  
**Causes damage to lungs**



**Insure compliance with**  
**OSHA 29 CFR §1926.1153**



SECTION 2.1: GENERAL

SECTION 2.2: MAINTENANCE AND WEAR PARTS REPLACEMENT MODES

SECTION 2.3: WORK SITE ASSESSMENT AND INSPECTION

SECTION 2.4: PERSONAL PROTECTIVE EQUIPMENT

SECTION 2.5: OPERATIONAL



## **SECTION 2.1: GENERAL**

Read and understand this Machine Manual prior to operating or performing maintenance on the BP-10-27.

This Machine Manual has been developed as a guideline for machine operation. It is not a substitute for proper organizational training and management.

All machine operators and maintenance personnel should be properly trained in operation and safety features of the BP-10-27.

Make these operating instructions accessible to all operating and maintenance personnel.

Never weld, modify, cut or grind components of the BP-10-27 without prior written consent from the manufacturer.

Never use aggressive cleaning chemicals to clean the machine.

All operators and maintenance personnel should receive training on the dangers of carbon monoxide, or CO. All personnel should be able to identify signs and symptoms of CO poisoning. Common signs associated with overexposure include headache, nausea, weakness, dizziness, lethargy, visual disturbances, and changes in personality and/or loss of consciousness.

## **SECTION 2.2: MAINTENANCE AND WEAR PARTS REPLACEMENT MODES**

Maintenance mode is defined as placing the machine in a configuration, which minimizes potential electric, hydraulic or stored energy hazards.

In general, the machine should be placed in Maintenance Mode prior to performing any maintenance and/or troubleshooting activities.

### **MAINTENANCE MODE:**

1. Move the machine to a level surface.
2. Reduce machine RPM to low idle.
3. Turn key switch to "OFF" position.
4. Remove key from switch to prevent accidental or unintended starting.
5. Block wheels to prevent the machine from moving.
6. Turn the LP bottle valve to "CLOSED" position.
7. Allow engine and exhaust tube to cool down prior to carrying out any maintenance work.



In general, the machine should be placed in Wear Parts Replacement Mode prior to changing the blade(s).

**WEAR PARTS REPLACEMENT MODE:**

1. Move the machine to a level surface.
2. Raise the blast head to the upper most position.
3. Reduce machine RPM to low idle.
4. Turn key switch to "OFF" position.
5. Remove key from switch to prevent accidental or unintended starting.
6. Place jack stands or blocks under blast head to ensure it does not move down.
7. Verify all rotating parts have stopped moving and are secured against unintended movement.

After performing any maintenance or repair work verify that all safety labels, guards, lids and bolted connections are properly and securely installed on the machine.

**SECTION 2.3: WORK SITE ASSESSMENT AND INSPECTION**

Before starting blasting operations, a site assessment must be performed. During the site assessment verify the following:

- Work area is flat, clean, and dry, free of debris, frost-free, and has no flammable liquids nearby. Also, make sure that the machine will be able to clear all obstructions. **NEVER BLAST A WET FLOOR. NEVER BLAST OVER BOLTS, NUTS, SCREWS, NAILS, OR OTHER DEBRIS AS THIS MAY RESULT IN SIGNIFICANT DAMAGE TO THE MACHINE AND SERIOUS INJURY TO THE OPERATOR.**
- Work area is well ventilated. **IF WORK AREA IS ENCLOSED OR PARTIALLY ENCLOSED (WAREHOUSE, PARKING GARAGE, TUNNELS, ETC.), THEN GASOLINE CAN NEVER BE USED AS THE FUEL SOURCE FOR THE BP-10-27 SHOT BLASTING MACHINE.** This is because carbon monoxide, which is a byproduct all internal combustion engines, can be extremely hazardous when allowed to accumulate in an area. An odorless, tasteless, and non-irritating gas, carbon monoxide can quickly become lethal. As a result, liquid propane must be used in all instances when the work area is enclosed or partially enclosed. **THE WORK AREA MUST STILL BE WELL VENTILATED, HOWEVER, AS LIQUID PROPANE ALSO RELEASES CARBON MONOXIDE. THIS MEANS THAT EXTREME CAUTION MUST STILL BE USED WHEN USING THIS FUEL SOURCE.**



- Each worker has a carbon monoxide monitor on their persons. These carbon monoxide monitors should be calibrated, in working order, and should be equipped with audible alarms that will warn workers if carbon monoxide levels become too high. **IF CARBON MONOXIDE LEVELS EXCEED 35 PARTS PER MILLION, ALL WORK MUST CEASE IMMEDIATELY! THIS REPRESENTS A POTENTIALLY DEADLY SITUATION WHICH NECESSITATES AN IMMEDIATE SHUTDOWN.**
- All workers have received training on the dangers of overexposure to carbon monoxide. Staff members must also be able to identify all of the signs and the symptoms associated with carbon monoxide poisoning. This training should ensure that work would stop immediately and emergency medical personnel would be notified promptly if one or more workers exhibited or complained of any of the common signs and symptoms associated with carbon monoxide overexposure, including: headache, nausea, weakness, dizziness, lethargy, visual disturbances, changes in personality, and/or loss of consciousness.
- All operators and other personnel within the work area have received training on proper ventilation procedures and on proper operation procedures for the engine and for other types of equipment.
- **FLOORS HAVE BEEN THOROUGHLY INSPECTED. SOME FLOOR OR DECK SURFACES MAY BE COATED WITH OR CONTAMINATED BY DANGEROUS MATERIALS SUCH AS:**
  - **PCBs**
  - **LEAD**
  - **ASBESTOS**
  - **PESTICIDES**
  - **SOLVENTS**
  - **CLEANING FLUIDS**
  - **AND/OR OTHER HARMFUL CHEMICALS**

**THE DUST PRODUCED FROM SHOT BLASTING SUCH SURFACES CAN CREATE A SERIOUS HEALTH THREAT TO THOSE WHO INHALE OR COME INTO CONTACT WITH THE DUST. THE WORK AREA MUST BE CHECKED FOR THESE MATERIALS BEFORE WORK CAN BEGIN. BLASTPRO MANUFACTURING, INC. DOES NOT WARRANT ITS EQUIPMENT TO BE SUITABLE FOR, OR APPROVED FOR, REMOVING DANGEROUS MATERIALS. IT IS THEREFORE THE RESPONSIBILITY OF THE CONTRACTOR TO CONFIRM THE SAFETY OF THE WORK AREA AND THE EQUIPMENT WITH THE PROPER AUTHORITIES. IT IS ALSO THE RESPONSIBILITY OF THE CONTRACTOR TO WARN ALL STAFF MEMBERS OF ALL THE**



**POTENTIAL SHORT-TERM AND LONG-TERM HEALTH RISKS ASSOCIATED WITH INHALING AND COMING INTO CONTACT WITH DANGEROUS MATERIALS. THE CONTRACTOR IS RESPONSIBLE FOR PROTECTING ALL WORKERS FROM BEING EXPOSED TO DANGEROUS MATERIALS. SINCE THE BP-10-27 SHOT BLASTING MACHINE HAS NOT BEEN DESIGNED TO REMOVE, CLEAN, PROFILE, OR ALTER ANY SURFACE COATED WITH OR OTHERWISE CONTAMINATED BY DANGEROUS MATERIALS, BLASTPRO MANUFACTURING, INC. EXPRESSLY DISCLAIMS ANY LIABILITY FOR INJURY, ILLNESS, DEATH, OR DAMAGE THAT MIGHT OCCUR OR RESULT FROM SUCH IMPROPER USE.**

- Operator and any other personnel in the work area are wearing safety glasses with side shields, dust masks, ear plugs, hard hats, steel toed work boots, long sleeved shirts, tight fitting clothing, and gloves. It is also imperative for staff to tie back long hair and to remove all jewelry.
- Work area has been blocked off to pedestrians, unprotected personnel, and untrained personnel. In the event pedestrians, unprotected personnel, or untrained personnel enter the work area, blasting operations are to be stopped immediately.
- Fire extinguishers are nearby. Also, take note of the location and the contact information of fire departments close to the work site.
- All guards and protective shields are properly installed and secured.
- All glass and equipment, including vehicles, are protected from steel shot. This can be done by loosely hanging a sheet of visqueen or other protective material in front of the glass or equipment in a curtain-like fashion. The importance of protecting glass and equipment from steel shot cannot be overemphasized.
- Plug or cover all floor drains to prevent steel shot from falling into the drains.
- This equipment is only to be used for commercial purposes. This equipment is only to be operated by professional, trained, and competent operators.
- The operator must be aware of their surroundings and use common sense. **THE OPERATOR IS NOT TO OPERATE THE EQUIPMENT IF HE IS TIRED, DISTRACTED, OR UNDER THE INFLUENCE OF DRUGS, ALCOHOL, OR MEDICATION THAT DECREASES AWARENESS.**



## **SECTION 2.4: PERSONAL PROTECTIVE EQUIPMENT**

All personnel working with, or in the vicinity of the BP-10-27 should, at a minimum, utilize the following PPE:

- Protective boots or shoes
- Eye protection with side shields
- Hearing protection
- Appropriate respiratory protection
- Protective leather gloves for handling blades

Additionally, all personnel should utilize a carbon monoxide monitor while working indoors. The BP-10-27 utilizes an internal combustion engine, which produces carbon monoxide, or CO. CO can be fatal at high exposure levels. In addition to CO monitoring equipment, the work site should be properly ventilated to minimize exposure potential.

All personnel should observe PPE requirements particular to each job site.

## **SECTION 2.5: OPERATIONAL**

When operating the BP-10-27, perform the following safety procedures:

- **SUPPORT PERSONNEL MUST KEEP A SAFE DISTANCE FROM THE MACHINE WHILE IT IS IN OPERATION! DO NOT STAND IN FRONT OF THE MACHINE WHILE IT IS IN OPERATION.**
- Since the speed of the machine determines the depth of its cut, it is advised that the operator run a test pattern. Failure to run a test pattern could result in the machine gouging the floor.
- The pattern needs to be inspected by the operator at least every ten feet as variation in concrete means that the concrete or the coated surface may be softer in some areas than it is in others.
- Whenever the dust collector becomes full, it must be emptied. Failure to empty the dust collector could result in the machine losing its suction to the floor. If this happens, then all of the shot will fall out of the shot hopper.
- If the gap between the blades and the wear bar is 3/16 of an inch or greater, then shot will begin to fall out of the machine. Eventually, all shot will escape if the gap between the blades and the wear bar remains at 3/16 of an inch or greater.



- **HYDRAULIC FLUID UNDER PRESSURE IS DANGEROUS AND CAN CAUSE SERIOUS INJURY OR EVEN DEATH. WHEN IGNITED, HYDRAULIC FLUIDS CAN EXPLODE AND/OR CAUSE FIRES.**
- **THE HYDRAULIC SYSTEM RUNS AT OR BELOW 500 PSI, NEVER LOOK FOR A LEAK WHEN THE BP-10-27 SYSTEM IS UNDER PRESSURE. HANDS SHOULD NEVER BE USED TO LOOK FOR A LEAK WHEN THE SYSTEM IS UNDER PRESSURE! EVEN A PINHOLE LEAK CAN CAUSE SERIOUS INJURY. THE LEAK COULD BE ALMOST INVISIBLE WHEN ESCAPING FROM A PINHOLE-SIZED LEAK. ESCAPING HYDRAULIC FLUID UNDER PRESSURE CAN PIERCE THE SKIN AND ENTER THE BODY. NEVER ALLOW PERSONNEL TO TOUCH ANY HYDRAULIC LINE OR FITTING WITH ANY PART OF THEIR BODY WHEN THE SYSTEM IS UNDER PRESSURE.**



MACHINE MANUAL  
MAINTENANCE

BP-10-27

SECTION 3.1: START-UP

SECTION 3.2: SHUT DOWN

SECTION 3.3: SHOT SELECTION

SECTION 3.4: TRANSPORT



### **SECTION 3.1: START-UP**

Only trained, authorized personnel should be allowed to run the BP-10-27. If training is needed, please consult with your Blastpro Manufacturing representative or authorized distributor.

Prior to start-up, the work surface should be inspected for hidden studs, electrical boxes, or any other hidden obstructions. These items should be removed or clearly marked so they can be avoided.

To move machine:

1. Verify that LP bottle is installed and has fuel in it.
2. Verify that the LP bottle valve is turned to the "OPEN" position.
3. Operator should be firmly seated in the operator's seat.
4. Turn the key switch to start until the motor starts (SEE FIGURE 3.1.1).
5. Increase the RPM enough to move the machine, but not to full throttle.
6. Only raise the blast head enough to clear obstacles. Some abrasive may escape, so it is important to minimize the gap between the seals and the surface.
7. Push lever forward to move forward; pull backward to reverse and use the steering wheel to guide the machine.
8. Move machine to desired location.

Normal Operation:

1. Verify that personnel are competent and that they have read and understood the safety information in this manual. Make certain that all personnel follow all safety instructions and programs required by their company and by the worksite.
2. Verify that the BP-10-27 is on a level, clean, debris-free, and dry surface.
3. Verify that the dust bin in the dust collector is empty.
4. Open propane tank valve.
5. Sit down in the seat of the BP-10-27.
6. Ground drive control lever is centered.
7. Make sure that the throttle is pushed all the way down.
8. Adjust throttle by pulling up on the throttle control.
9. Lock throttle for shot blasting by turning the throttle clockwise.
10. Turn the ignition switch to the ON position.
11. To steer the machine, rotate the steering wheel in the desired direction.
12. Start moving the machine forward and then slowly open up the shot valve (the slower the machine moves while the blast wheel is engaged, the deeper the cut will be to the underlying surface).



13. When arriving at a stopping point, shut off the shot valve about ten feet before stopping the machine. Performing this operation will clear the machine's housing of shot which will prevent the BP-10-27 from blasting a hole in the underlying surface when it comes to a complete stop.
14. Turn ignition switch on BP-10-27 to the OFF position.

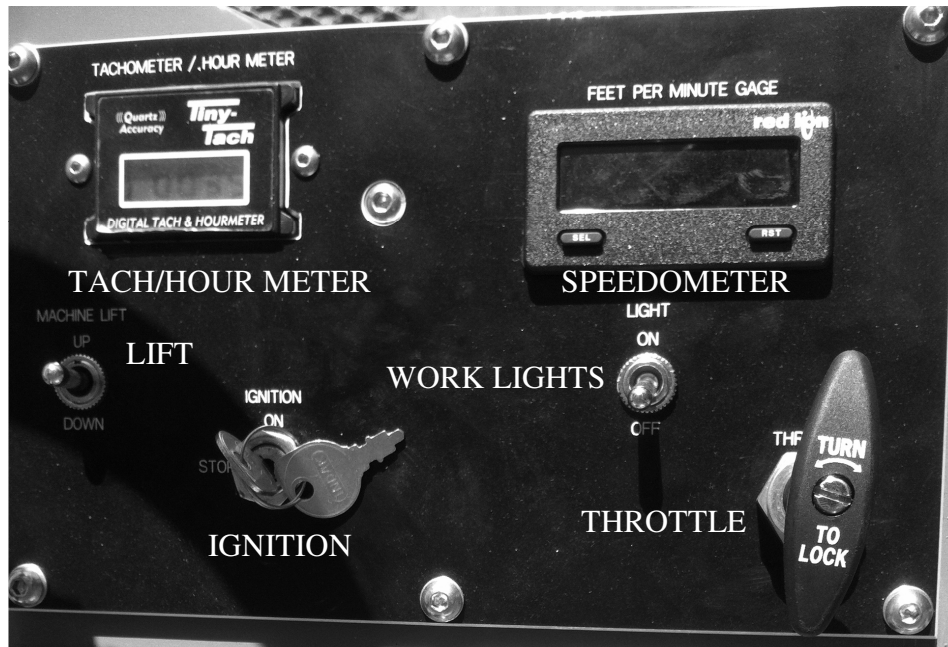

FIGURE 3.1.1

### Operational Adjustments:

The BP-10-27 can be manipulated to make blasting easier for the operator.

- **Wear Bar:** Before operating the BP-10-27, the wear bar clearance must be checked by the operator. The wear bar should have 3/16 of an inch of clearance for all applications in order to ensure the best blasting results. After adjusting the wear bar, it is highly recommended that the operator spin the blast wheel to make certain that all blades have clearance.
- **Vacuum Adjust Plate:** This plate allows the operator to adjust the amount of vacuum force that is pulled through the blast housing. It can be adjusted to alter the amount of air flow allowed. Located within the shot hopper, opening this plate allows more vacuum force and air flow. Closing this plate, conversely, dampens/restricts the vacuum force and air flow.
- **Front End Lift:** Although used primarily for loading and unloading the BP-10-27, this feature can also be used to adjust the blasting seals while the



machine is in operation. This allows the operator to adjust the seals without having to stop the machine and manually manipulate the seals.

- **Seals:** In order to set the seals to the correct height, first make sure that the machine is on a level surface. Then, put the BP-10-27 in a slow forward motion. Next, bump the machine lower switch until the front seal touches the surface being blasted and bends slightly. Finally, stop the machine and assure that the side seals are also touching the floor.

#### **Additional Operational Considerations:**

- **SUPPORT PERSONNEL MUST KEEP A SAFE DISTANCE FROM THE MACHINE WHILE IT IS IN OPERATION. DO NOT STAND IN FRONT OF THE MACHINE WHILE IT IS IN OPERATION.**
- Since the speed of the machine determines the depth of its cut, it is advised that the operator run a test pattern. Failure to run a test pattern could result in the machine gouging the floor.
- The pattern needs to be inspected by the operator at least every ten feet as variation in concrete means that the concrete or the coated surface may be softer in some areas than it is in others.
- Whenever the dust collector becomes full, it must be emptied. Failure to empty the dust collector could result in the machine losing its suction to the floor. If this happens, then all of the shot will fall out of the shot hopper.
- If the gap between the blades and the wear bar is 3/16 of an inch or greater, then shot will begin to fall out of the machine. Eventually, all shot will escape if the gap between the blades and the wear bar remains at 3/16 of an inch or greater.
- **HYDRAULIC FLUID UNDER PRESSURE IS DANGEROUS AND CAN CAUSE SERIOUS INJURY OR EVEN DEATH! WHEN IGNITED, HYDRAULIC FLUIDS CAN EXPLODE AND/OR CAUSE FIRES.**
- **THE HYDRAULIC SYSTEM RUNS AT OR BELOW 500 PSI, NEVER LOOK FOR A LEAK WHEN THE BP-10-27 SYSTEM IS UNDER PRESSURE. HANDS SHOULD NEVER BE USED TO LOOK FOR A LEAK WHEN THE SYSTEM IS UNDER PRESSURE. EVEN A PINHOLE LEAK CAN CAUSE SERIOUS INJURY. THE LEAK COULD BE ALMOST INVISIBLE WHEN ESCAPING FROM A PINHOLE-SIZED LEAK. ESCAPING HYDRAULIC FLUID UNDER PRESSURE CAN PIERCE THE SKIN AND ENTER THE BODY. NEVER ALLOW PERSONNEL TO TOUCH ANY HYDRAULIC LINE OR FITTING WITH ANY PART OF THEIR BODY WHEN THE SYSTEM IS UNDER PRESSURE.**



### SECTION 3.2: SHUT DOWN

At end of shift or work day:

1. Move machine to level ground for storage.
2. Lower the blast head until the seals just touch the surface.
3. Lower RPM to low idle.
4. Turn key switch to "OFF" position.
5. Remove key to protect against unauthorized operation.
6. Turn the LP bottle valve to "CLOSED" position.

For long term storage:

The steps for long term storage are the same as the end-of-shift/day procedures, with a few additions. For long term storage, the LP tank should be removed and stored in a secure location. Additionally, the BP-10-27 should be covered to protect it from dust and moisture.

Additional Steps for Machine Shut Down or Storage:

- Empty dust from the dust collector. **WHEN REMOVING DUST FROM DUST COLLECTOR, ALWAYS WEAR A PARTICLE MASK. CONCRETE DUST MAY CONTAIN PARTICLES WHICH ARE EXTREMELY HAZARDOUS! THESE PARTICLES SHOULD NEVER BE INHALED.**
- Empty all shot from the shot hopper on the BP-10-27. Shot should never be left in BP-10-27 after work is performed. Never move or transport BP-10-27 with shot in the shot hopper as this may result in damage to the equipment.
- **AFTER COMPLETING WORK, CLEAN ALL STRAY SHOT FROM WORK AREA. SHOT CAN BE CLEANED WITH A MAGNETIC BROOM OR WITH A SHOP VACUUM. NEVER LEAVE STRAY SHOT IN WORK AREA AS SHOT REPRESENTS A SLIP AND FALL HAZARD! STEPPING AND FALLING ON STEEL SHOT CAN RESULT IN SERIOUS INJURY OR EVEN DEATH.**



### **SECTION 3.3: SHOT SELECTION**

The BP-10-27 can utilize a variety of shot. Selection of shot is important to achieve the most efficient removal, cleaning and profiling of the surface. Incorrect shot selection can lead to increased production times and cost.

In general, if the machine is being used to simply profile a surface, a smaller shot size should be used. This will provide more impacts per square inch, resulting in a better profile.

If the job calls for heavy removal, a larger shot size should be used. This will result in fewer impacts, but each impact will carry more momentum for removal.

Jobs involving heavy removal, which also need a more aggressive profile, can employ mixed shot sizes. This will allow for more efficient removal of material by the larger shot, while imparting a profile with the smaller shot.

For particularly difficult removal jobs, such as non-skid on naval vessels, grit can be used. The irregular, angular nature of grit will speed wear on internal components. Generally, grit should be mixed with shot to achieve a more aggressive removal, while trying to minimize wear to internal components.



### SECTION 3.4: TRANSPORT

Only use factory installed tie-down/lifting lugs when transporting or moving the equipment (SEE FIGURE 3.4.1).



**FIGURE 3.4.1**

Verify that lifting straps or chains are rated for the weight of the machine.

Verify that trailer or truck bed is rated for the weight of the machine.

Remove all shot from the hopper and dust from the dust collector prior to loading onto a truck or trailer.

Never allow personnel to stand under the machine when it is being lifted.

Verify that LP bottle valve is in “CLOSED” position and that the bottle is securely stored during transport.



- SECTION 4.1: WEAR BAR REMOVAL AND INSTALLATION
- SECTION 4.2: BLAST WHEEL REMOVAL AND INSTALLATION
- SECTION 4.3: TOP LINER REMOVAL AND INSTALLATION
- SECTION 4.4: BLADE REMOVAL AND INSTALLATION
- SECTION 4.5: DUST COLLECTOR FUNCTION AND MAINTENANCE
- SECTION 4.6: PARTS LIST
- SECTION 4.7: ELECTRICAL SCHEMATIC



## **SECTION 4.1: WEAR BAR REMOVAL AND INSTALLATION**

**PLACE THE MACHINE INTO MAINTENANCE MODE PRIOR TO PERFORMING ANY MAINTENANCE. SEE SECTION 2.2.**

When the blast wheel is turned the blades are as close as possible to the wear bar. There should be a gap of no more than 1/8 of an inch. If the gap is greater than 1/8 of an inch, the wear bar will need to be repositioned.

**Caution:** All power must be disconnected and all rotation parts completely stopped before attempting any maintenance procedure.

1. Remove the Pinch Bar retaining lug.
2. Insert a slide hammer into the threaded hole in the end of the Pinch Bar.  
NOTE: Slide hammer is provided with all Pinch Bar machines.
3. Withdraw the Pinch Bar from the blast head.
4. Insert the new Pinch Bar and tap into place with a hammer.
5. Reinstall the Pinch Bar lug bolt.

**Caution:** All power must be disconnected and all rotation parts completely stopped before attempting any maintenance procedure.

1. Remove the Pinch Bar retaining lug.
2. Rotate the Pinch Bar clockwise one notch if it does not exceed 1/8 inch from blast wheel blades.
3. If Pinch Bar gap is larger than 1/8 inch, the Pinch Bar should be rotated two (2) notches clockwise.
4. Rotate Pinch Bar with a large adjustable wrench.
5. Reinstall the Pinch Bar lug bolt.

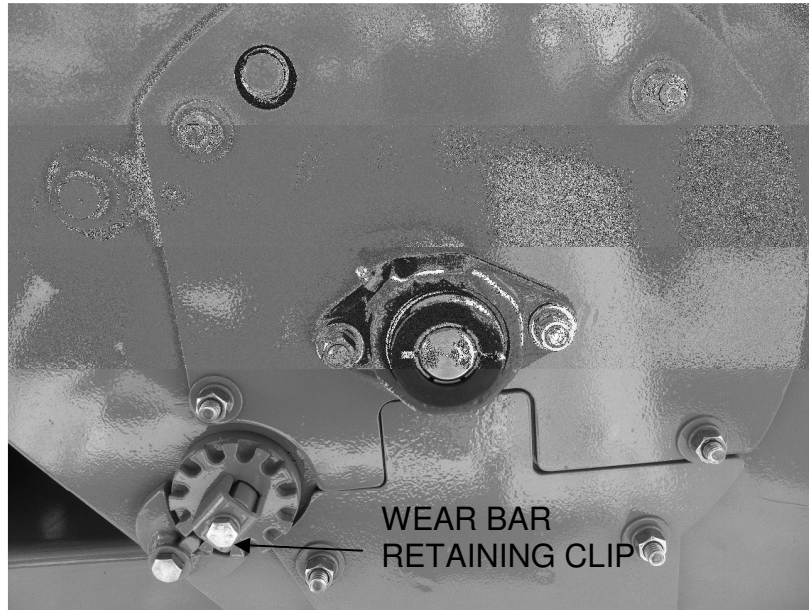

**FIGURE 4.1.1**

## **SECTION 4.2: BLAST WHEEL REMOVAL AND INSTALLATION**

**PLACE THE MACHINE INTO MAINTENANCE MODE PRIOR TO PERFORMING ANY MAINTENANCE. SEE SECTION 2.2.**

### **Blast Wheel Removal:**

#### **1. Belts:**

- a) Remove the seat for better access to the work area.
- b) Remove the lower portion of the belt guard and take the six belts off the blast wheel sheave using a flathead screwdriver.

#### **2. Taper Lock and Sheave Assembly:**

- a) Remove the two set screws from the taper lock.
- b) Install one set screw in the hole, which did not originally have a set screw.
- c) Tighten the set screw until you hear the taper lock “pop”. If the taper lock does not pop, tap the outside of it lightly with a hammer.
- d) Slide the taper lock off the shaft. If the assembly does not slide off the shaft easily, insert a screwdriver in the slot and pull off.

**Note:** Be careful not to pry open too far as the taper lock can split in half.



3. **Bearing Collar:**
  - a) Remove the two Allen head set screws on each of the two bearing collars.
  - b) Remove the bearing collars.
4. **Blast Wheel Bearing:**
  - a) Remove the two bolts holding the outside bearing.
  - b) Pry the outside bearing off of the shaft.
5. **Inspection Plate:**
  - a) Remove the two bolts, which connect the inspection plate to the housing.
  - b) Remove the inspection plate.
6. **Cover Plate:**
  - a) Remove the four nuts, which connect the cover plate to the housing.
  - b) Remove the cover plate.
7. **Blast Wheel:**
  1. Remove the blast wheel drum by pulling the drum shaft through the inside bearing.  
**Note:** If the drum shaft is resistant to come through the bearing, you may use a block of wood and a hammer to force it through.

Install the new blast wheel by reversing the blast wheel removal steps listed above. Make sure that all the liners come together, that the blast wheel blades are aligned and are parallel to the edge of the wear bar, and that the blast wheel is centered equidistant from both sides of the inside of the housing.

#### **SECTION 4.3: TOP LINER REMOVAL AND INSTALLATION**

**PLACE THE MACHINE INTO MAINTENANCE MODE PRIOR TO PERFORMING ANY MAINTENANCE. SEE SECTION 2.2.**

##### **Top Liner Removal:**

1. **COMPLETE BLAST WHEEL REMOVAL BEFORE ATTEMPTING TO REMOVE THE TOP LINER.**
2. Remove the two 1/2 inch bolts and washers that hold the top liner in place.  
**Note: These bolts and washers are on both sides of the outside of the housing, just above and to the rear of the machine from where the blast wheel is.**
3. There is a nut behind a protective bar attached to the bottom front on the top liner; loosen this nut all the way.



**Note: You will have to go underneath and inside the housing to access this nut.**

4. Rotate the top liner slightly clockwise until you can see the tabs through a small square cutout that the bolts went in to.
5. Pull the top liner out.

#### **Top Liner Installation:**

Install the new top liner by reversing the top liner removal steps listed above.

### **SECTION 4.4: BLADE REMOVAL AND INSTALLATION**

**PLACE THE MACHINE INTO MAINTENANCE MODE PRIOR TO PERFORMING ANY MAINTENANCE. SEE SECTION 2.2.**

1. Remove inspection plate below outside blast wheel bearing by removing the 1/2 inch nuts and washers and the one 3/8 inch nut and washer (SEE FIGURE 4.4.1).
2. Remove the liner located behind the outside inspection plate.
3. Remove the four Allen head screws that hold the blade retainers.
  - a. Rotate blast wheel until one of the blades is straight up.
  - b. Insert Allen wrench through the small notch at the top center of the blast wheel retaining plate.
  - c. Remove the screw.
  - d. Rotate blast wheel ninety degrees, or a quarter of a turn, and remove the next screw.
  - e. Repeat two more times.
4. Pull retaining ring out and allow it to drop down.
5. Remove each blade individually by pulling each out with pliers or vice grips and then turning the blast wheel one quarter of a turn to remove the next blade.

**Note: If the blade is difficult to remove, then it may be necessary to remove the inside inspection plate and knock the blade out with a hammer and a large punch or something similar.**

6. Replace blades individually in the same manner that they were removed.

**Note: Never replace individual blades. When replacing blades, all must be removed and replaced as a set.**
7. Replace retainers and screws.
8. Replace the half moon liner and upper outside inspection plate.

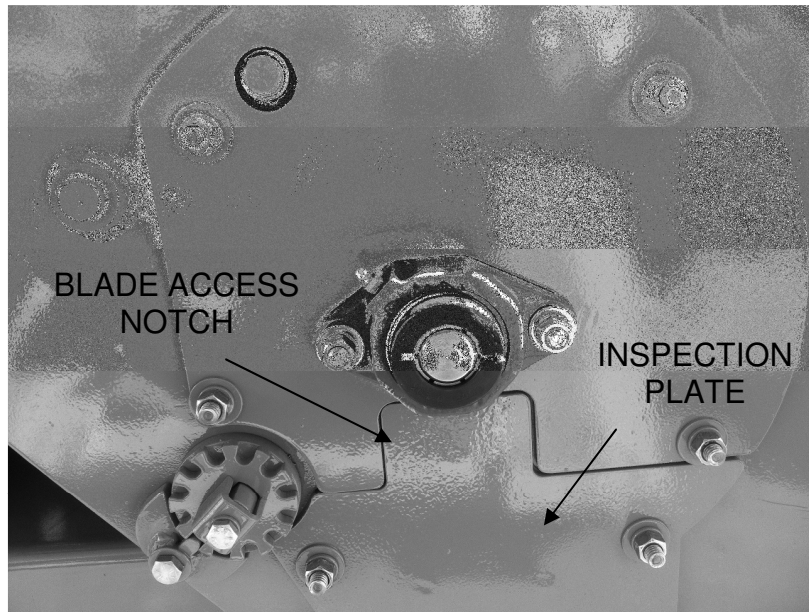

**FIGURE 4.4.1**

## **SECTION 4.5: DUST COLLECTOR FUNCTION AND MAINTENANCE**

### **Dust Collector Function:**

The BP-10-27 shot blasting machine is equipped with an auto pulse dust collector that helps to both separate the dust from the shot and to return clean air back into the environment.

The most fundamental part of the dust collector is referred to as the filter chamber. Air containing dust particles enters the filter chamber from the blasthead via the exhaust hose. This air then moves into the dust collector inlet connection located on the left, front side of the dust collector. Next, the air passes through a plenum and moves through eight filter cartridges. These eight filter cartridges capture the dust particles and prevent them from moving on with the air. Now dust-free, the air then passes to the clean air portion of the dust collector where it is subsequently released back into the environment by way of the silencer box.

The dust captured by the filter cartridges is removed at regular intervals. This dust is removed by the pulsing of the filter cartridges with a blast of compressed air released from the header tank by means of a diaphragm valve. One of the BP-10-27's three blow-down tubes delivers the compressed air. The temporary pulse of compressed air causes the dust to plummet into the dust bins located at



the base of the filter chamber. Three filters are sequentially pulsed. The timing of the pulsing is determined by a timer board which is located in the control box on the front of the dust collector. The timer board is typically configured so as to pulse a three filter section every ten seconds. The timer board acts to determine the time between pulses and the length of each pulse. Venturi valves are positioned above each filter cartridge to increase the effectiveness of the filter cleaning process.

### **Dust Collector Maintenance:**

The dust collector must be examined on a regular basis. This is because adequate ventilation is essential for the dust collector. It is therefore essential that the following areas are routinely examined.

- Leaks on the blower housing assembly seal and on the dust collector access door seal should be kept at a minimum. The dust collector access door seal can be checked for leaks by carefully feeling for air leaks around the seal.
- Check door seal for missing or damaged sections.
- The hose connections between the blast head and the dust collector must be tight and kept in place with the use of metal clamps.
- The hose must be in good condition. Flattened spots, holes, and wear spots should be corrected without haste. Hose must be replaced if necessary.
- Filter cartridges must be kept in good, working condition.

If the dust collector is not in proper, working order, this can have a detrimental effect on the entire system. Improper ventilation can result in inadequate abrasive cleaning which hastens blast wheel and liner wear. It is essential that the dust collector be well maintained. A dust collector that receives timely, regular maintenance will result in less abrasive contamination which will help to both reduce operating costs and increase overall effectiveness.



**Filter Cartridge Removal:**

**PLACE THE MACHINE INTO MAINTENANCE MODE PRIOR TO PERFORMING ANY MAINTENANCE. SEE SECTION 2.2.**

Filter cartridges can be accessed through the same door from which the dust is removed. To remove filter cartridges:

1. Remove dust from the dust collector with a shovel.
2. Remove wing nut from the bottom of the filter cartridge.
3. Slide filter cartridge down hanger rod.

To replace filter cartridges reverse steps 2-3 above.



**SECTION 4.6: PARTS LIST**

PART NUMBER	DESCRIPTION	QTY
BT08300173	10-18 SEAL PINCH BAR	1
BTSL023506	SIDE SEAL FOR BLASTHOUSING	2
BTSL023507	FRONT SEAL FOR BLASTHOUSING	1
BTWP163711	REAR BRUSH	1
BTWP193708	ABRASIVE CONTROL SEAL	1
BTWP183709	RETAINER/ABR CNTL VALVE SEAL/	2
BTWP103710	PINCH BAR LINER 1018	1
BTWP103713	LOWER PINCH BAR LINER 10-18	1
BTP000524	BLASTHOUSING 10-27	1
BTP000526	BLAST HOUSING INSP COVER 10-18	1
BTWP033710	PINCH BAR 1018	1
BT08300044	RETAINER OUTER PINCH BAR 10-18	1
BT06150031	3/3V 4.75 SHEAVE	1
BT06300024	1610 X 1 TL BUSHING	1
BT06100006	3VX425 V-BELT/BLASTWHEEL 1018	3
BTP001083	2 BOLT FLANGE BR 1018 BW	2
BT08300170	SHAFT SEAL GPX 10-18LP	2
BT08300173	10-18 SEAL PINCH BAR	1
BTP000525	HOUSING COVER PLATE 10-18	1
BTWKIT1018	DOVETAIL BLADES 1018/ SET OF 3	1
BTP001183	BELT GUARD/FRONT/GPX 10-18	1
BT4835510	CLAMP/DE-STA-CO 351	1
BT4835510-BLOCK	BT4833510-MOUNTING BLOCK	1
SHAFT COLLAR-05	1" SHAFT COLLAR	4
BT06430030	10 X 3 CASTER 10-18	3
BT02100002	1" PILLOW BLOCK BEARING 10-18	1
BT07300010	TRANSAXLE CABLE 10-18	1
BT03400013	E CLIP/FOR 1.0" OD SHAFT .822	2
BT03500004	Wave Washer, 1" I.D.	2
BT4528370	OFF SET LINK # 40 CHAIN	1
BT4920110	CHAIN ASA #40 10'feet 1 box	2
BT4920110-1	MASTER LINK #40 CHAIN	1
BT02110025	10-18 PILOT BEARING 1" STEERIN	2
BT02110026	10-18 LIFT PILOT BEARING	2
BT08300137-A	1 SPROCKET	1
BT08300007	FRONT FORK ASSEMBLY 1018	1
BT06300064	1500 LB LIFT ACTUATOR 10-18	1
BT-06-550-17	RIGHT ANGLE CORD GRIP	4
BTP000510	DECK WELDMENT 10-18	1
BT06600001	TRANSAXLE ASSBLY 10-18	1
BT06800001	PUMP TRANSAXLE/ CCW ROTATION	1
BT06300030	17MM TAPERLOCK/FOR 06150002	1
BT06300064	1500 LB LIFT ACTUATOR 10-18	1



MACHINE MANUAL  
MAINTENANCE

BP-10-27

BT08300075	KEY/REAR WHEEL GPX 10-18	2
BT03400013	E CLIP/FOR 1.0" OD SHAFT .822	2
BTP004043	1018 DUST COLLECTOR	1
BT4984990	HANGER RODS 9-54	6
BT4932060	FILTER/ELEMENT 6-54 9-54	6
BT06150007	1GR3V6.9 PULLEY 10-27	1
BT02110003	2 BOLT FLANGE BRG 1 1/8"	2
BT09100002	HOUSING/BLOWER #PB-12A CCW	1
BT09200003	BLOWER/WHEEL 14 X 3.25	1
BT4835510	CLAMP/DE-STA-CO 351	2
BT4835510-BLOCK	BT483510-MOUNTING BLOCK	2
BP75000001	SHEAVE BLOWER SHAFT 10-18	1
BP75000002	T/L BUSHING BLOWER SHAFT 10-18	1
BT6765530	GOYEN VALVE 9-54 dust coll-17	2
BTP001181	WIRING HARNESS 1018	1
BTP004044	SILENCER BOX 1018	1
ZT-00043	COMPRESSOR	1
ZT-00043-1	FILTER/SILENCER	1
BT06150001	SHEAVE/TL 1A4.2BF.6-1610	1
BTP003734	ENGRAVED LEGEND PLATE 10-18	1
BT-06300065	500 LB ACTUATOR 1018	1
BT6749040	VENTURI 2186900	6
ZT-00006	GEAR BOX BELT-3VX560	1
BELT SYSTEMS-05	3VX710 V-BELT	1
BT06100006	3VX425 V-BELT/BLASTWHEEL 1018	3
BT06120005	ACCULINK BELT	5
BT03130002	U BOLT 7/16" X 2" X 5" 10-27	4
BP1027-0001	36" BRAIDED AIRLINE	1
BT6916120	SHOT VALVE NIPPLE	1
BTP004104	ENGINE ASSEMBLY 27 HP	1
BTP001409-27HP	27HP MOTOR FOR 10-27	1
BT06150045	SHEAVE/TL 4GR3V8.0-2517	1
BT06300025	1610 TAPERLOCK 1 1/8"	1
BT06300052	2517 X 1 1/8" TL BUSHING	1
BT07100030	MUFFLER TIP 1018/BMS 270	1
BTP000882	IDLER ASSEMBLY GPX 10-18	1
BTP003066	TERMINAL HOUSING 5P CABLE 1018	1
PIPE ELBOW-01	3/8" ELBOW BLACK PIPE	1
PIPE NIPPLES-07	3/8" X 6" BLACK PIPE NIPPLE	1
PIPE NIPPLES-06	3/8" X 3" BLACK PIPE NIPPLE	1
PIPE CAP-01	3/8" PIPE CAP BLACK	1
BTP001409-8	VAPORIZER ASSBLY/W FILTER	1
BTP001409-13	REGULATOR 25HP/KOEHLER	1
BP75000503	3/8" LPG GAS HOSE	1



**SECTION 4.7: ELECTRICAL SCHEMATIC**

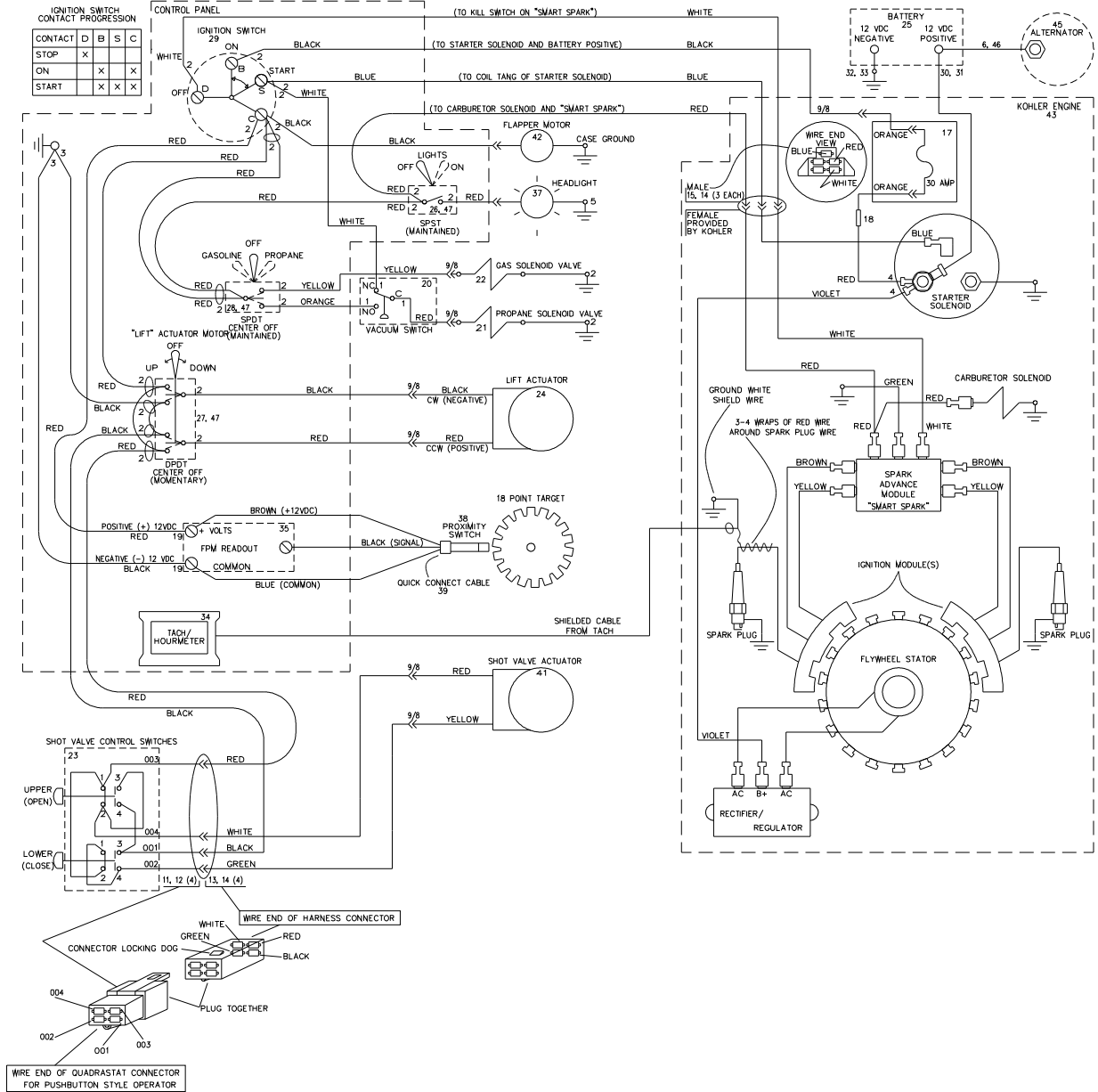



**SECTION 4.8: MAINTENANCE CHECK LIST**

The items on the check list must be inspected before each operation. This will maximize production and minimize down time. Always place machine into “Maintenance Mode” prior carrying out any maintenance or repairs. See Machine Manual Section 2.2.

	Blast wheel	Check for balance and excessive wear.
	Blades	Check for excessive wear. Change blades as a kit.
	Top and Lower liner	Check for excessive wear; Change when ½ worn through.
	Pinch Bar	Check for proper clearance and excessive wear.
	Pinch Bar/Blade Gap	Gap should be approximately 1/8” – 3/16”. Rotate pinch bar ¼ turn every 8 hours of operation.
	Blast Wheel Bearings	Check and tighten set screws as necessary. Apply 5 pumps of grease every 8-10 hours of operation <sup>2</sup> .
	Shot Valve	Check for shot leaks.
	Filters	Inspect filters for damage. Replace if clogged with dust. <b>DO NOT BANG FILTERS ON THE GROUND.</b>
	Engine Oil	Check level. Change oil every 100 hours <sup>1</sup> .
	Air Cleaner	Check for dirty, loose or damaged parts. Change every 100 hours <sup>1</sup> .
	Transmission Oil	Inspect transmission for leaks.
	Axle Seals	Inspect for leaks.
	Blast Housing seals	Inspect for excessive wear. Insure seals provide a solid seal around the blast housing.
	Blower Bearings	Check and tighten set screws as necessary. Apply 5 pumps of grease every 8-10 hours of operation <sup>2</sup> .
	Steering Assembly	Check chain tension. Check and tighten set screws as necessary. Apply 1 pump of grease to bearings every 40 hours of operation <sup>2</sup> .
	Belts	Check condition and tension. Re-tension as necessary and replace damaged belts.



	Idler Assembly	Check and tighten set screws as necessary. Apply 1 pump of grease to bearing every 40 hours. <sup>1</sup>
	Dust Collector Latches	Verify latches securely close the dust collector door. Adjust as necessary. Replace damaged latches.
	Air Compressor Oil <sup>2</sup>	Check level. Change at 20 hours (New comp. break in) Change at 40 hours (New comp. break in) Change every 100 hours (Following break in period). <sup>3</sup>
	Air Tank Water Drain	Drain water from the air tank.
	Other Engine Maintenance	See Engine "Owner's Manual" for additional maintenance points and schedule

1. Care should be taken not to over-grease bearings.  
Recommended: Mystik JT6 Hi-Temp multi-purpose grease.
2. Use only SAE 30, non-detergent, single-viscosity, compressor oil.
3. Perform maintenance interval more frequently under extremely dusty conditions.

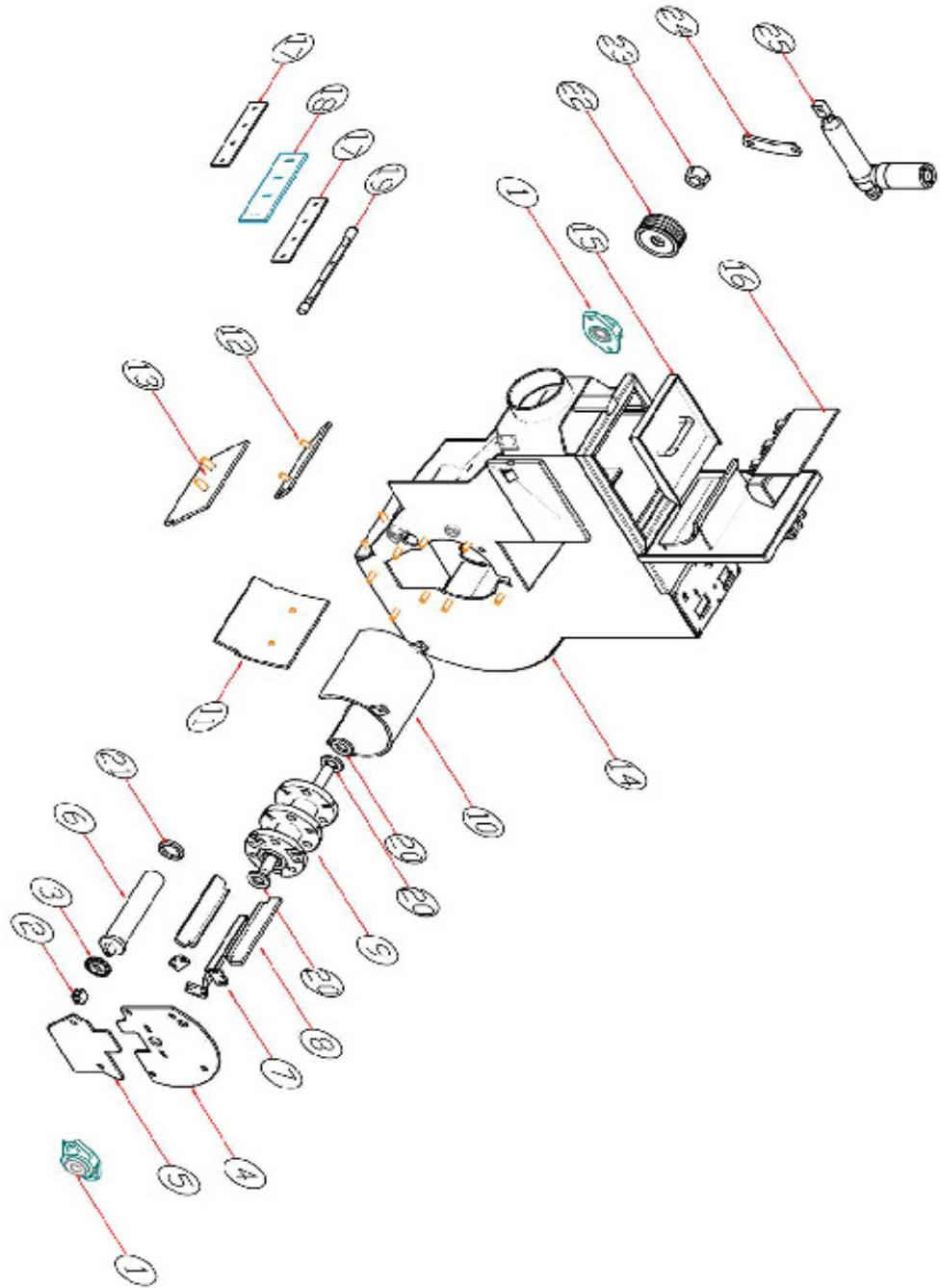

4.



ITEM	PART NUMBER	DESCRIPTION
1	BTP001083	BLASTWHEEL BEARING
2	BT08300093	RETAINER CLIP
3	BT08300042	PINCH BAR INDEXER
4	P000525	COVER PLATE
5	P000526	INSPECTION DOOR
6	WP033710	PINCH BAR
7	BT08300172	BLADE RETAINER
8	BTWKIT 10-18	BLASTWHEEL BLADE
9	WP123716	BLASTWHEEL
10	WP113721	TOP LINER
11	BP75000504	FRONT LINER
12	WP103710	PINCH BAR LINER
13	WP103713	LOWER PINCH BAR LINER
14	BTP000524	BLAST HOUSING
15	BT08300107	SHOT HOPPER SCREEN
16	BT08300100	SHOT TRAY
17	BTWP183709	SHOT VALVE SEAL PLATE
18	BTWP193708	SHOT VALVE SEAL
19	BTWP203710	SHOT VALVE SHAFT
20	BT08300170	SHAFT SEAL
21	BT08300173	PINCH BAR SEAL
22	BT06150031	TAPER LOCK SHEAVE
23	BT06300024	TAPER LOCK BUSHING
24	BT08300030	ABRASIVE CONTROL ARM
25	BT06300065	ACTUATOR/#500



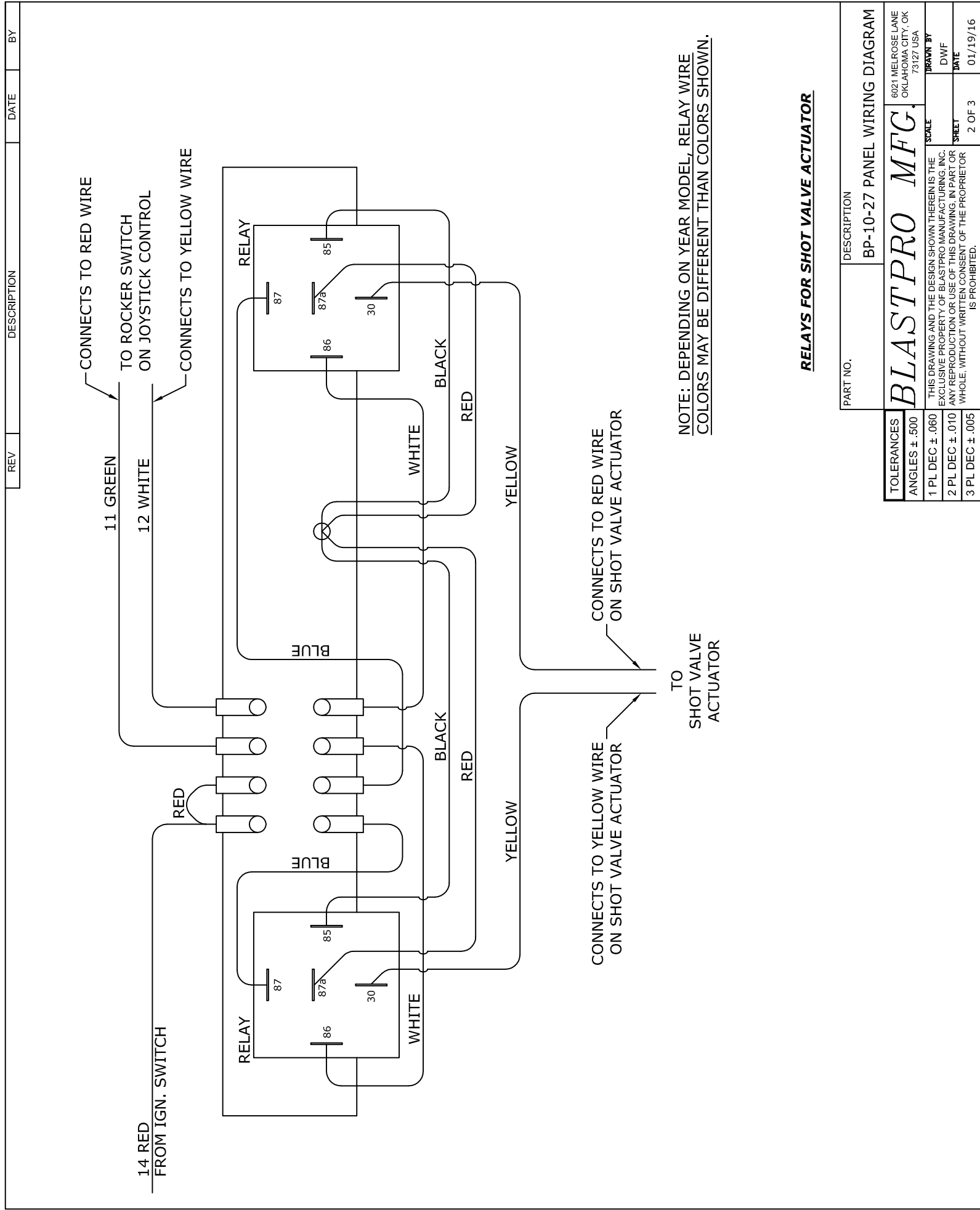

NOTE: DEPENDING ON YEAR MODEL, RELAY WIRE COLORS MAY BE DIFFERENT THAN COLORS SHOWN.

**RELAYS FOR SHOT VALVE ACTUATOR**

REV		DESCRIPTION		DATE		BY	
PART NO.		DESCRIPTION		BP-10-27 PANEL WIRING DIAGRAM		6021 MELROSE LANE OKLAHOMA CITY, OK 73127 USA	
TOLERANCES		BLASTPRO MFG.		SCALE		DRAWN BY	
ANGLES ± .500		THIS DRAWING AND THE DESIGN SHOWN THEREIN IS THE EXCLUSIVE PROPERTY OF BLASTPRO MANUFACTURING, INC. ANY REPRODUCTION OR USE OF THIS DRAWING, IN PART OR WHOLE, WITHOUT WRITTEN CONSENT OF THE PROPRIETOR IS PROHIBITED.		1 PL DEC ± .060		DWF	
1 PL DEC ± .060				2 PL DEC ± .010		DATE	
2 PL DEC ± .010				3 PL DEC ± .005		2 OF 3	
3 PL DEC ± .005						01/19/16	

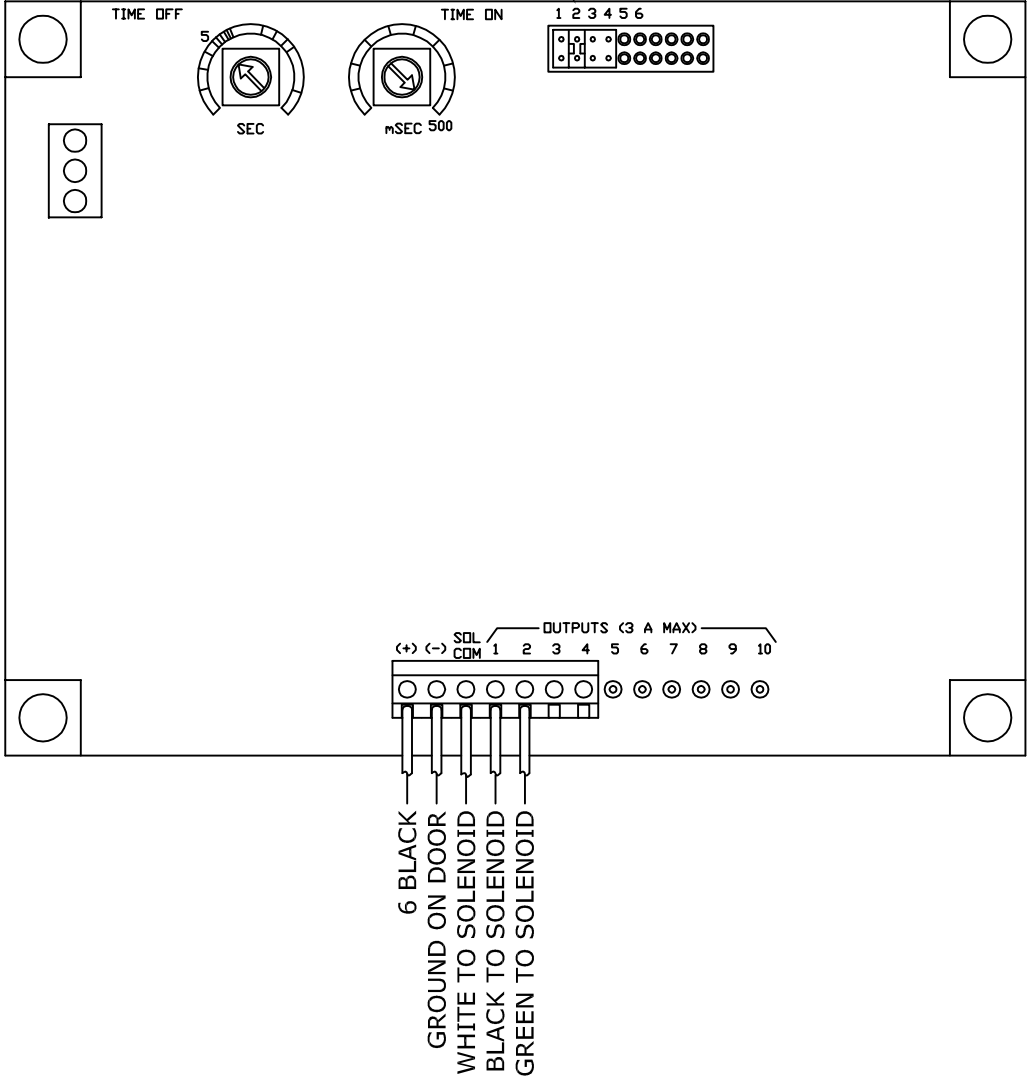
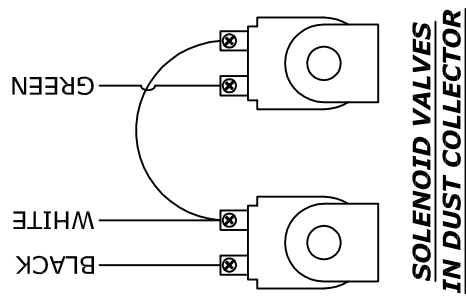

**TIMER BOARD ON DUST COLLECTOR**

PART NO.		DESCRIPTION	
BP-10-27		PANEL WIRING DIAGRAM	
TOLERANCES		SCALE	
ANGLES ± .500	1 PL DEC ± .060	6021 MELROSE LANE OKLAHOMA CITY, OK 73127 USA	
2 PL DEC ± .010	3 PL DEC ± .005	DRAWN BY	DWFF
		DATE	01/19/16
THIS DRAWING AND THE DESIGN SHOWN THEREIN IS THE EXCLUSIVE PROPERTY OF BLASTPRO MANUFACTURING, INC. ANY REPRODUCTION OR USE OF THIS DRAWING, IN PART OR WHOLE, WITHOUT WRITTEN CONSENT OF THE PROPRIETOR IS PROHIBITED.			

**BLASTPRO MFG.**

EFI Wiring Diagram 5-Terminal Connector (Key Switch Optional)

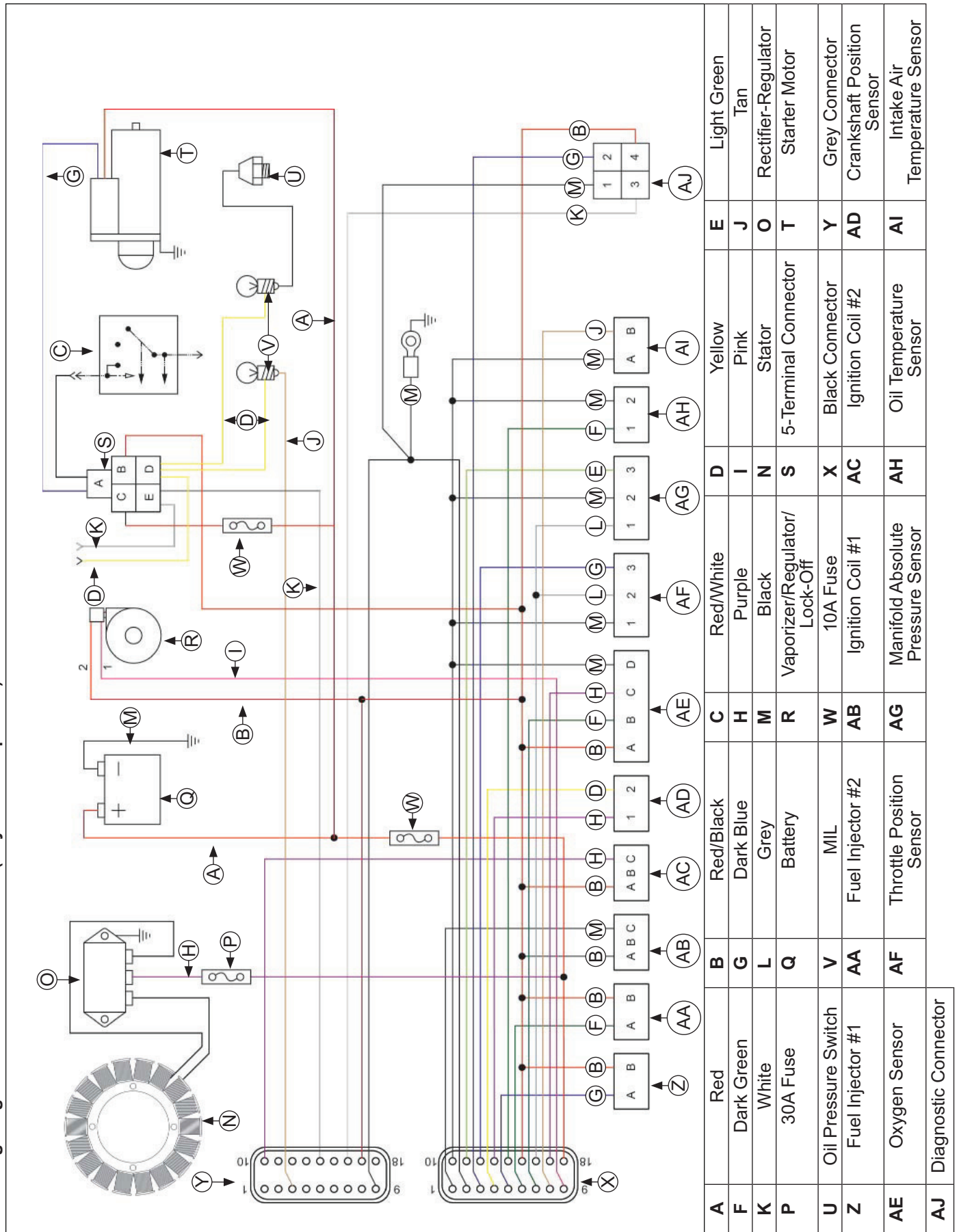

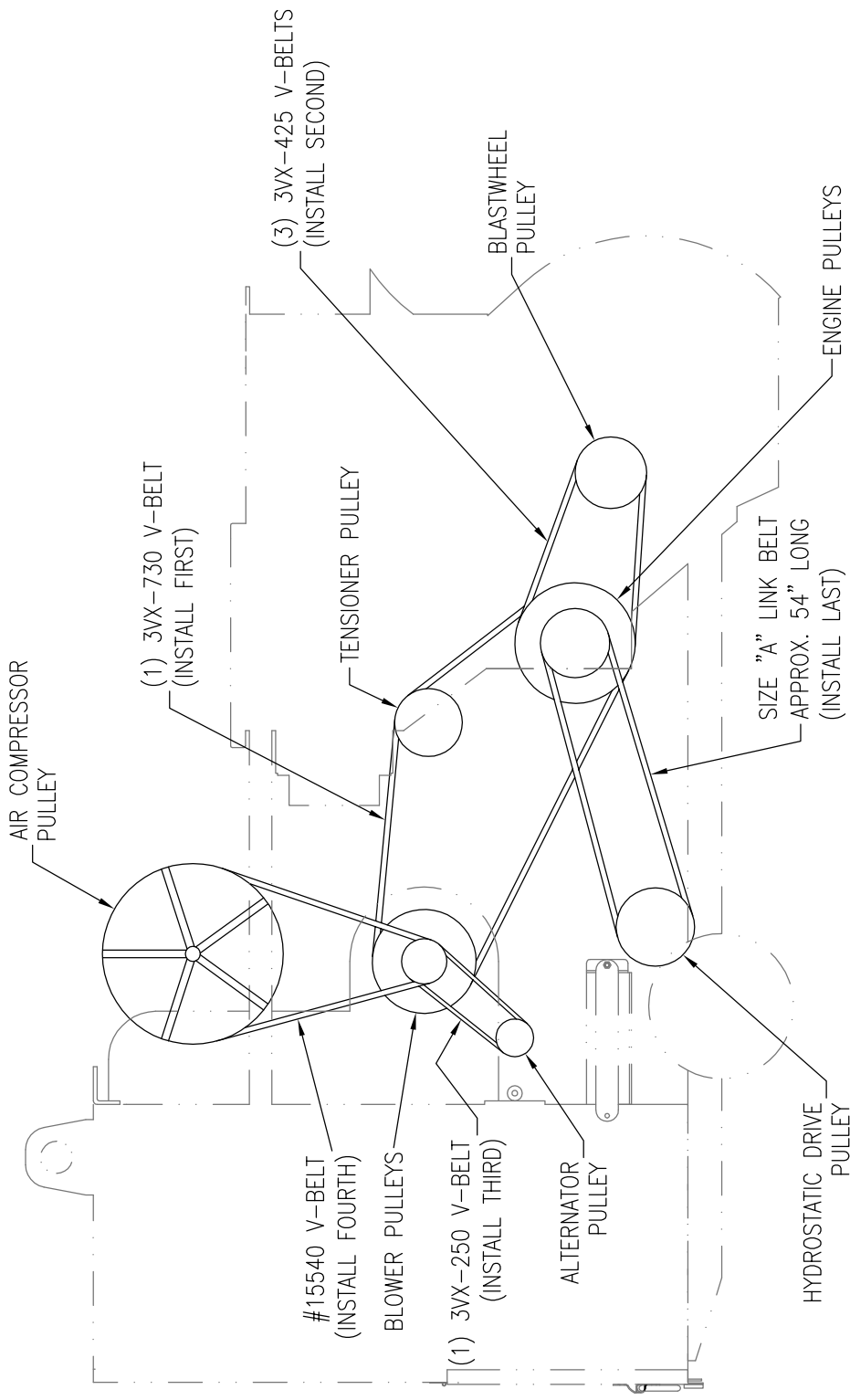

NOTE: INSTALL BELTS IN THE ORDER SHOWN.  
STARTING WITH THE BELT CLOSEST TO THE ENGINE.

PART NO.		DESCRIPTION	
		BP 10-27 BELT DIAGRAM	
TOLERANCES		SCALE	
ANGLES ± .500		6021 MELROSE LANE OKLAHOMA CITY, OK 73127 USA	
1 PL DEC ± .060		DRAWN BY	DWF
2 PL DEC ± .010		DATE	06/10/16
3 PL DEC ± .005		SHEET	1 OF 1

**BLASTPRO MFG.**

THIS DRAWING AND THE DESIGN SHOWN THEREIN IS THE EXCLUSIVE PROPERTY OF BLASTPRO MANUFACTURING, INC. ANY REPRODUCTION OR USE OF THIS DRAWING, IN PART OR WHOLE, WITHOUT WRITTEN CONSENT OF THE PROPRIETOR IS PROHIBITED.

# KOHLER® Command PRO

PCH680, PCH740

PCV680, PCV740

Propane Electronic Fuel Injection (EFI)

## Owner's Manual

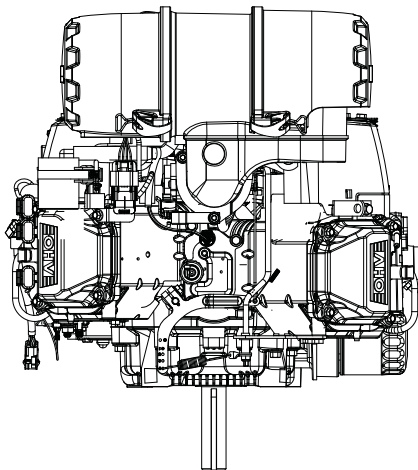
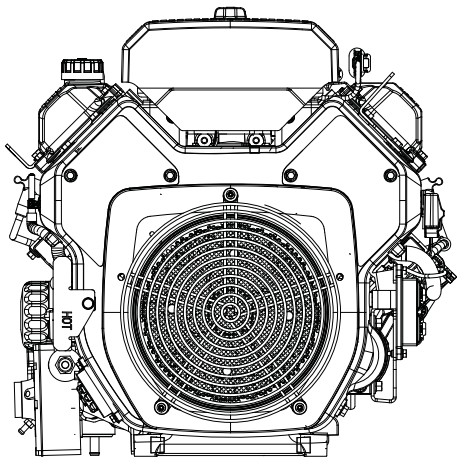

---

**IMPORTANT:** Read all safety precautions and instructions carefully before operating equipment. Refer to operating instruction of equipment that this engine powers.

Ensure engine is stopped and level before performing any maintenance or service.

Warranty coverage as outlined in warranty card and on [KohlerEngines.com](http://KohlerEngines.com). Please review carefully as it provides you specific rights and obligations.

To maintain compliance with applicable emission regulations, exhaust system backpressure may not exceed limits which can be found on [KohlerEngines.com](http://KohlerEngines.com). Search by Model No., select Read More, then select Specs tab.

---

Record engine information to reference when ordering parts or obtaining warranty coverage.

Engine Model \_\_\_\_\_

Specification \_\_\_\_\_

Serial Number \_\_\_\_\_

Purchase Date \_\_\_\_\_

## Safety Precautions

**⚠ WARNING:** A hazard that could result in death, serious injury, or substantial property damage.

**⚠ CAUTION:** A hazard that could result in minor personal injury or property damage.

NOTE: is used to notify people of important installation, operation, or maintenance information.

	<p><b>⚠ WARNING</b></p> <p>Explosive Fuel can cause fires and severe burns.</p> <p>If a gaseous odor is detected, ventilate area and contact an authorized service technician.</p>
	<p>Propane is extremely flammable and is heavier than air and tends to settle in low areas where a spark or flame could ignite gas. Do not start or operate this engine in a poorly ventilated area where leaking gas could accumulate and endanger safety of persons in area.</p> <p>To ensure personal safety, installation and repair of propane fuel supply systems must be performed only by qualified propane system technicians. Improperly installed and maintained propane equipment could cause fuel supply system or other components to malfunction, causing gas leaks.</p> <p>Observe federal, state and local laws governing propane fuel, storage, and systems.</p>

<p>Propane is extremely flammable and is heavier than air and tends to settle in low areas where a spark or flame could ignite gas. Do not start or operate this engine in a poorly ventilated area where leaking gas could accumulate and endanger safety of persons in area.</p> <p>To ensure personal safety, installation and repair of propane fuel supply systems must be performed only by qualified propane system technicians. Improperly installed and maintained propane equipment could cause fuel supply system or other components to malfunction, causing gas leaks.</p> <p>Observe federal, state and local laws governing propane fuel, storage, and systems.</p>
--

	<p><b>⚠ WARNING</b></p> <p>Carbon Monoxide can cause severe nausea, fainting or death.</p> <p>Avoid inhaling exhaust fumes.</p>
	<p>Engine exhaust gases contain poisonous carbon monoxide. Carbon monoxide is odorless, colorless, and can cause death if inhaled.</p>

<p>Engine exhaust gases contain poisonous carbon monoxide. Carbon monoxide is odorless, colorless, and can cause death if inhaled.</p>
--

	<p><b>⚠ WARNING</b></p> <p>High Pressure Fluids can puncture skin and cause severe injury or death.</p> <p>Do not work on fuel system without proper training or safety equipment.</p>
	<p>Fluid puncture injuries are highly toxic and hazardous. If an injury occurs, seek immediate medical attention.</p>

<p>Fluid puncture injuries are highly toxic and hazardous. If an injury occurs, seek immediate medical attention.</p>
---



	<p><b>⚠ WARNING</b></p> <p>Rotating Parts can cause severe injury.</p> <p>Stay away while engine is in operation.</p>
	<p>Keep hands, feet, hair, and clothing away from all moving parts to prevent injury. Never operate engine with covers, shrouds, or guards removed.</p>

<p>Keep hands, feet, hair, and clothing away from all moving parts to prevent injury. Never operate engine with covers, shrouds, or guards removed.</p>
---

	<p><b>⚠ CAUTION</b></p> <p>Electrical Shock can cause injury.</p> <p>Do not touch wires while engine is running.</p>
	<p>Never operate engine with heat shields or guards removed.</p>

<p><b>California Proposition 65 Warning</b></p> <p>Engine exhaust from this product contains chemicals known to State of California to cause cancer, birth defects, or other reproductive harm.</p>
---

<p><b>California Proposition 65 Warning</b></p> <p>This product contains chemicals known to State of California to cause cancer, birth defects, or other reproductive harm.</p>
---

  	<p><b>⚠ WARNING</b></p> <p>Accidental Starts can cause severe injury or death.</p> <p>Disconnect and ground spark plug lead(s) before servicing.</p>
	<p>Before working on engine or equipment, disable engine as follows: 1) Disconnect spark plug lead(s). 2) Disconnect negative (-) battery cable from battery.</p> <p>Before disconnecting negative (-) ground cable, make sure all switches are OFF. If ON, a spark will occur at ground cable terminal which could cause an explosion if hydrogen gas or propane fuel vapors are present.</p>

<p>Before working on engine or equipment, disable engine as follows: 1) Disconnect spark plug lead(s). 2) Disconnect negative (-) battery cable from battery.</p> <p>Before disconnecting negative (-) ground cable, make sure all switches are OFF. If ON, a spark will occur at ground cable terminal which could cause an explosion if hydrogen gas or propane fuel vapors are present.</p>
--

	<p><b>⚠ WARNING</b></p> <p>Hot Parts can cause severe burns.</p> <p>Do not touch engine while operating or just after stopping.</p>
	<p>Never operate engine with heat shields or guards removed.</p>

<p>Never operate engine with heat shields or guards removed.</p>
--

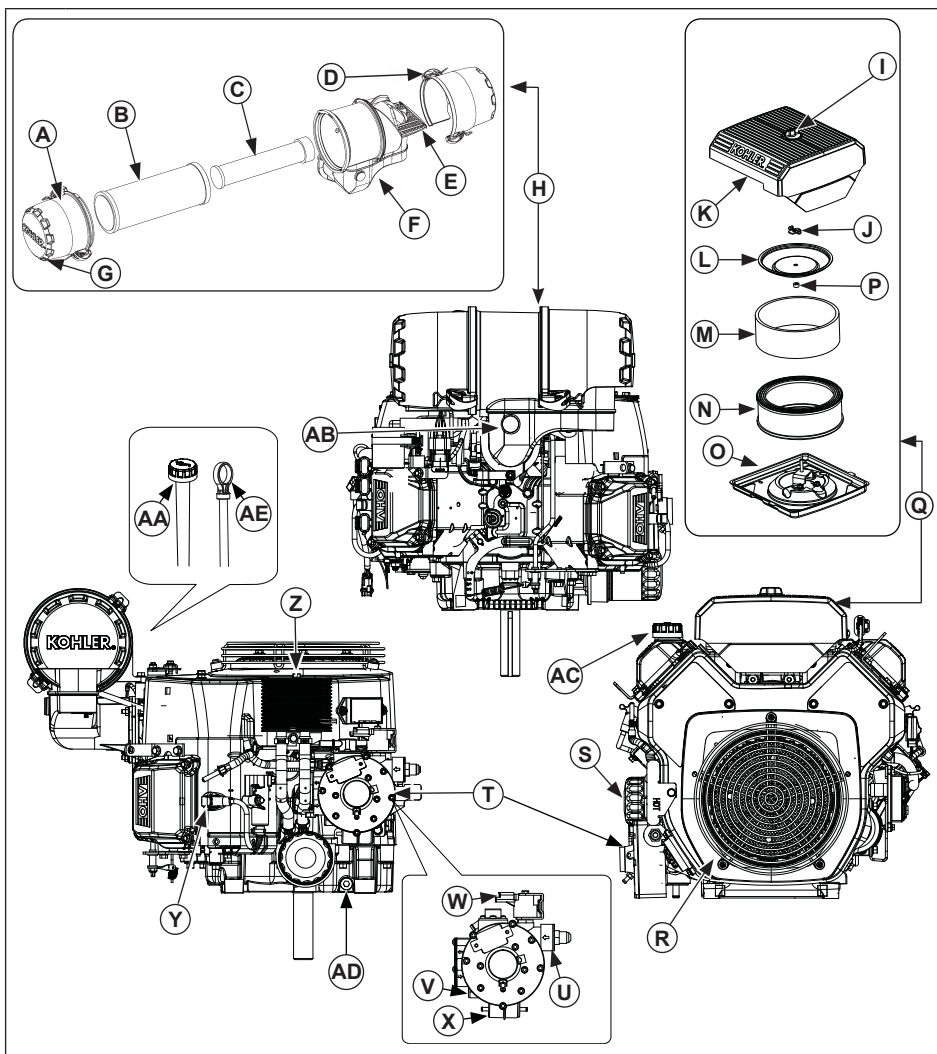

<b>A</b>	End Cap	<b>B</b>	Element	<b>C</b>	Inner Element	<b>D</b>	Retaining Clip
<b>E</b>	Inlet Screen	<b>F</b>	Air Cleaner Housing	<b>G</b>	Ejector Area	<b>H</b>	Heavy-Duty Air Cleaner
<b>I</b>	Air Cleaner Knob	<b>J</b>	Wing Nut	<b>K</b>	Air Cleaner Cover	<b>L</b>	Element Cover
<b>M</b>	Precleaner	<b>N</b>	Paper Element	<b>O</b>	Air Cleaner Base	<b>P</b>	Rubber Seal
<b>Q</b>	Low-Profile Air Cleaner	<b>R</b>	Debris Screen	<b>S</b>	Oil Filter	<b>T</b>	Vaporizer/Regulator
<b>U</b>	Vaporizer/Regulator Inlet Filter	<b>V</b>	Vaporizer/Regulator Drain Plug	<b>W</b>	Lock-Off	<b>X</b>	Unique EFI Fuel Filter
<b>Y</b>	Spark Plug	<b>Z</b>	Oil Cooler	<b>AA</b>	Oil Fill/Dipstick	<b>AB</b>	Filter Minder
<b>AC</b>	Oil Fill	<b>AD</b>	Oil Drain Plug	<b>AE</b>	Dipstick		

Visit [KohlerEngines.com](http://KohlerEngines.com) for service parts information and purchasing options.

## Pre-Start Checklist

1. Check oil level. Add oil if low. Do not overfill.
2. Check fuel gauge (if equipped). If propane tank is low, have it refilled. Check fuel system components and lines for leaks.
3. Check and clean cooling areas, air intake areas and external surfaces of engine (particularly after storage).
4. Check that air cleaner components and all shrouds, equipment covers, and guards are in place and securely fastened.
5. Check spark arrestor (if equipped).

## Starting



### **WARNING**

Carbon Monoxide can cause severe nausea, fainting or death.  
Avoid inhaling exhaust fumes.

Engine exhaust gases contain poisonous carbon monoxide. Carbon monoxide is odorless, colorless, and can cause death if inhaled.



### **WARNING**

Rotating Parts can cause severe injury.  
Stay away while engine is in operation.

Keep hands, feet, hair, and clothing away from all moving parts to prevent injury. Never operate engine with covers, shrouds, or guards removed.

**NOTE:** Do not crank engine continuously for more than 10 seconds. Allow a 60 second cool down period between starting attempts. Failure to follow these guidelines can burn out starter motor.

**NOTE:** Upon start-up, a metallic ticking may occur. Run engine for 5 minutes. If noise continues, run engine at mid throttle for 20 minutes. If noise persists, take engine to your local Kohler authorized dealer.

1. Place throttle control midway between slow and fast positions.
2. Slowly turn fuel valve on propane tank to full open position.
3. Turn key switch to START position. Release switch as soon as engine starts. If starter does not turn engine over, shut off key switch immediately. Do not make further attempts to start engine until condition is corrected. Do not jump start. See your Kohler authorized dealer for trouble analysis.

## Cold Weather Starting Hints

1. Use proper oil for temperature expected.
2. Disengage all possible external loads.

## Stopping

1. If possible, remove load by disengaging all PTO driven attachments.
2. Turn fuel valve to full closed position and allow engine to continue running until it runs out of fuel. Turn key switch to OFF position.



## Angle of Operation

Refer to operating instructions of equipment this engine powers. Do not operate this engine exceeding maximum angle of operation; see specification table. Engine damage could result from insufficient lubrication.

## Engine Speed

**NOTE:** Do not tamper with governor setting to increase maximum engine speed. Overspeed is hazardous and will void warranty.

## Maintenance Instructions

	 <b>WARNING</b>	<p>Before working on engine or equipment, disable engine as follows: 1) Disconnect spark plug lead(s). 2) Disconnect negative (-) battery cable from battery.</p>
	<p>Accidental Starts can cause severe injury or death.</p> <p>Disconnect and ground spark plug lead(s) before servicing.</p>	

Normal maintenance, replacement or repair of emission control devices and systems may be performed by any repair establishment or individual; however, warranty repairs must be performed by a Kohler authorized dealer found at KohlerEngines.com or 1-800-544-2444 (U.S. and Canada).

For safety and health reasons, many states require special licensing or certification for servicing propane fuel systems. Check local and state regulations before choosing a repair establishment to perform fuel system repairs.

## Maintenance Schedule

### Every 25 Hours<sup>1</sup>

- Service/replace low-profile precleaner (if equipped).

### Every 100 Hours<sup>1</sup>

- Check oil cooler fins, clean as necessary (if equipped).
- Change oil.
- Replace low-profile air cleaner element (if equipped).
- Remove cooling shrouds and clean cooling areas.

### Every 150 Hours<sup>1</sup>

- Check heavy-duty filter minder.
- Inspect heavy-duty air filter paper element and inlet screen area.

### Every 200 Hours<sup>1</sup>

- Change oil filter.
- Replace unique EFI fuel filters.

### Every 300 Hours<sup>1</sup>

- Replace heavy-duty air cleaner element and check inner element.

### Every 500 Hours or Annually<sup>1</sup>

- Check all lines (high pressure/vacuum) including fittings for leaks.
- Drain vaporizer/regulator of accumulated fuel deposits.
- Replace spark plugs and set gap.

### Every 500 Hours or Annually<sup>1,2</sup>

- Inspect lock-off assembly for damage/leakage.
- Have combustion deposits removed if using non-synthetic oil.

### Every 600 Hours or Annually<sup>1</sup>

- Replace heavy-duty air cleaner inner element.

### Every 1500 Hours<sup>1,2</sup>

- Have vaporizer/regulator tested.

<sup>1</sup> Perform these procedures more frequently under severe, dusty, dirty conditions.

<sup>2</sup> Must be performed by a Kohler authorized dealer or qualified propane personnel only.

## Oil Recommendations

Synthetic oil is recommended for use in propane fueled engines. Non-synthetic oil must be low ash\* rated oil. Oils (including synthetic) must meet API (American Petroleum Institute) service class SG, SH, SJ, or SL. Select viscosity based on air temperature at time of operation as shown in table below.

\*Low ash is defined as less than 1% sulfated ash.

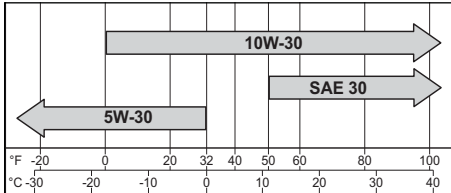

## Check Oil Level

**NOTE:** To prevent extensive engine wear or damage, never run engine with oil level below or above operating range indicator on dipstick.

Ensure engine is cool. Clean oil fill/dipstick areas of any debris.

1. Remove dipstick; wipe oil off.
  - a. Press-in cap: reinsert dipstick into tube; press completely down.  
or
  - b. Thread-on cap: reinsert dipstick into tube; rest cap on tube, do not thread cap onto tube.
2. Remove dipstick; check oil level. Level should be at top of indicator on dipstick.
3. If oil is low on indicator, add oil up to top of indicator mark.
4. Reinstall and secure dipstick.

## Change Oil and Filter



Change oil while engine is warm.

1. Clean area around oil fill cap/dipstick and drain plug. Remove drain plug and oil fill cap/dipstick. Allow oil to drain completely.
2. Clean area around oil filter. Place a container under filter to catch any oil and remove filter. Wipe off mounting surface. Reinstall drain plug. Torque to 10 ft. lb. (13.6 N·m).
3. Place new filter in shallow pan with open end up. Fill with new oil until oil reaches bottom of threads. Allow 2 minutes for oil to be absorbed by filter material.
4. Apply a thin film of clean oil to rubber gasket on new filter.
5. Refer to instructions on oil filter for proper installation.
6. Fill crankcase with new oil. Level should be at top of indicator on dipstick.
7. Reinstall oil fill cap/dipstick and tighten securely.
8. Start engine; check for oil leaks. Stop engine; correct leaks. Recheck oil level.
9. Dispose of used oil and filter in accordance with local ordinances.

## Oil Sentry™ (if equipped)

This switch is designed to prevent engine from starting in a low oil or no oil condition. Oil Sentry™ may not shut down a running engine before damage occurs. In some applications this switch may activate a warning signal. Read your equipment manuals for more information.

## Fuel Recommendations

	 <b>WARNING</b>
	<p>Explosive Fuel can cause fires and severe burns.</p> <p>If a gaseous odor is detected, ventilate area and contact an authorized service technician.</p>
<p>Propane is extremely flammable and is heavier than air and tends to settle in low areas where a spark or flame could ignite gas. Do not start or operate this engine in a poorly ventilated area where leaking gas could accumulate and endanger safety of persons in area.</p> <p>To ensure personal safety, installation and repair of propane fuel supply systems must be performed only by qualified propane system technicians. Improperly installed and maintained propane equipment could cause fuel supply system or other components to malfunction, causing gas leaks.</p> <p>Observe federal, state and local laws governing propane fuel, storage, and systems.</p>	

This engine is certified to operate on commercial propane (per GPA STD 2140). If you have any questions, contact your propane supplier.

Propane from an appropriate propane fuel tank (supplied separately) is required to operate this engine.

## Vaporizer/Regulator

In compliance with government emission standards, vaporizer/regulator is preset at factory to provide proper supply of fuel. No adjustment or resetting of vaporizer/regulator is to be made. All service relating to vaporizer/regulator must be performed by a Kohler authorized dealer or qualified propane personnel only.

Vaporizer/regulator can change propane from supply tank to a gaseous/vapor state.

Lock-Off assembly opens and closes controlling fuel flow from supply tank before reaching vaporizer/regulator.

Over time, fuel deposits can accumulate inside vaporizer/regulator. Removing these deposits is recommended. Follow steps below to drain vaporizer/regulators.



1. Turn fuel supply valve off, run engine out of fuel, and turn off ignition switch.
2. Disconnect and ground spark plug leads.
3. Remove drain plug from bottom of vaporizer/regulator. Remove any accumulated deposits.

4. Reinstall plug and tighten securely. If required, a replacement plug can be found at KohlerEngines.com.

## Fuel Line

High pressure fuel line meeting a minimum of SAE R7 standard must be installed on Kohler Co. engines equipped with propane EFI system (from vaporizer/regulator to injectors).

## Spark Plugs

	 <b>CAUTION</b>
	<p>Electrical Shock can cause injury.</p> <p>Do not touch wires while engine is running.</p>

Clean out spark plug recess. Remove plug and replace.

1. Check gap using wire feeler gauge. Adjust gap, see specification table for adjustment.
2. Install plug into cylinder head.
3. Torque plug to 20 ft. lb. (27 N·m).

## Electronic Fuel Injection (EFI) System

EFI is an electronically-controlled fuel management system which is monitored by an Electronic Control Unit (ECU). A Malfunction Indicator Light (MIL) will illuminate if problems or faults are detected. Servicing by a Kohler authorized dealer is necessary.

## Fuel System Components

Engines are equipped with special EFI fuel filters. See Maintenance Schedule.

## Fuse Replacement

This engine has three (3) blade type automotive fuses. Replacement fuses must have same rating as blown fuse. Use fuse chart below to determine correct fuse.

Wire Color	Fuse Rating
2 Solid Red Wires	10-amp Fuse
1 Red Wire with Black Stripe 1 Red Wire with White Stripe	10-amp Fuse
2 Purple Wires	30-amp Fuse

## Air Cleaner

NOTE: Operating engine with loose or damaged air cleaner components could cause premature wear and failure. Replace all bent or damaged components.

NOTE: Paper element cannot be blown out with compressed air.

### Low-Profile

Loosen knob and remove air cleaner cover.

Precleaner:

1. Remove precleaner from paper element.
2. Replace or wash precleaner in warm water with detergent. Rinse and allow to air dry.
3. Saturate precleaner with new engine oil; squeeze out excess oil.
4. Reinstall precleaner over paper element.

Paper Element:

1. Clean area around element. Remove wing nut, element cover, and paper element with precleaner.
2. Separate precleaner from element; service precleaner and replace paper element.
3. Check condition of rubber seal and replace if necessary.
4. Install new paper element on base; install precleaner over paper element; reinstall element cover and secure with wing nut.

Reinstall air cleaner cover and secure with knob.

### Heavy-Duty

1. Unhook retaining clips and remove end cap(s).
2. Check and clean inlet screen (if equipped).
3. Pull air cleaner element out of housing and replace. Check condition of inner element; replace when dirty.
4. Check all parts for wear, cracks, or damage, and that ejector area is clean.
5. Install new element(s).
6. Reinstall end cap(s) with dust ejector valve/screen down; secure with retaining clips.

## Breather Tube (if equipped)

Ensure end of breather tube is properly connected.

## Oil Cooler (if equipped)

1. Clean fins with a brush or compressed air.
2. Remove two screws securing oil cooler, and tilt to clean back side.
3. Reinstall oil cooler.

## Air Cooling

	<b>! WARNING</b>
	Hot Parts can cause severe burns. Do not touch engine while operating or just after stopping.
Never operate engine with heat shields or guards removed.	

Proper cooling is essential. To prevent over heating, clean screens, cooling fins, and other external surfaces of engine. Avoid spraying water at wiring harness or any electrical components. See Maintenance Schedule.

## Repairs/Service Parts

We recommend that you use a Kohler authorized dealer for all maintenance, service, and engine parts. To find a Kohler authorized dealer visit [KohlerEngines.com](http://KohlerEngines.com) or call 1-800-544-2444 (U.S. and Canada).

## Leakage Check/Testing

With fuel valve fully opened, engine not running, turn key switch ON. Check all fuel system connections and lines for leaks using soapy water. Any leakage must be corrected before restarting engine. Have service performed by a Kohler authorized dealer or qualified propane personnel only.

## Storage

If engine will be out of service for 2 months or more follow procedure below.

1. Change oil while engine is still warm from operation. Remove spark plug(s) and pour about 1 oz. of engine oil into cylinder(s). Replace spark plug(s) and crank engine slowly to distribute oil.
2. Disconnect negative (-) battery cable.
3. Separate propane tank from unit and store separately in an area designated for safe propane tank storage.
4. Store engine in a clean, dry place.

## Troubleshooting

Do not attempt to service or replace major engine components, or any items that require special timing or adjustment procedures. This work should be performed by a Kohler authorized dealer.

### Possible Cause

Problem	Possible Cause											
	No Fuel	Tank Nearly Empty	Improper Fuel	Dirt In Fuel Line	Broken Fusible Link	Dirty/ Restricted Vaporizer/ Regulator Inlet Filter	Dirty Debris Screen	Incorrect Oil Level	Engine Overloaded	Dirty Air Cleaner	Faulty Spark Plug	Dirty/ Restricted Vaporizer/ Regulator
Will Not Start	•			•	•	•	•	•	•	•	•	•
Hard Starting	•		•	•		•	•	•	•	•	•	•
Stops Suddenly	•			•		•	•	•	•	•		•
Lacks Power		•	•	•		•	•	•	•	•	•	•
Operates Erratically			•	•		•	•	•	•	•	•	•
Knocks or Pings			•			•	•	•			•	•
Skips or Misfires			•	•		•	•			•	•	•
Backfires				•		•				•	•	•
Overheats			•	•		•		•		•		•
High Fuel Consumption										•		•

<b>Engine Specifications</b>						
<b>Model</b>	<b>Bore</b>	<b>Stroke</b>	<b>Displacement</b>	<b>Oil Capacity (Refill)</b>	<b>Spark Plug Gap</b>	<b>Maximum Angle of Operation (@ full oil level)*</b>
PCH680	3.27 in. (83 mm)	2.72 in. (69 mm)	45.6 cu. in. (747 cc)	1.7-2.0 U.S. qt. (1.6-1.9 L)	0.03 in. (0.76 mm)	25°
PCV680						
PCH740						
PCV740						

\*Exceeding maximum angle of operation may cause engine damage from insufficient lubrication.

Additional specification information can be found in service manual at [KohlerEngines.com](http://KohlerEngines.com).

Exhaust Emission Control System for propane EFI models PCH680, PCH740, and PCV680, PCV740 is EM, O2S, ECM, MPI for U.S. EPA, California, and Europe.

Any and all horsepower (hp) references by Kohler are Certified Power Ratings and per SAE J1940 & J1995 hp standards. Details on Certified Power Ratings can be found at [KohlerEngines.com](http://KohlerEngines.com).



