

ARRAY™

Smart Deadbolt
Secure control from anywhere.™

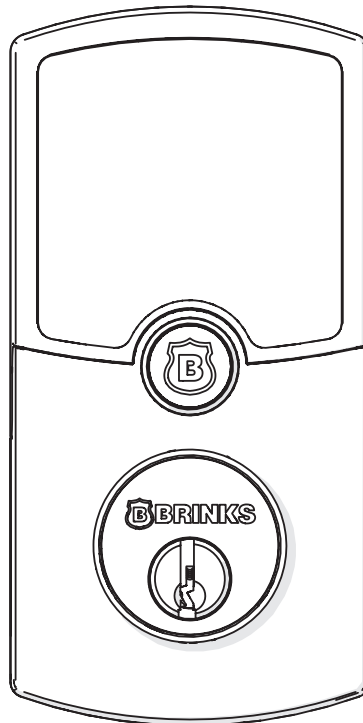

Installation Instructions

Simply Smart Security.™

Installation Instructions

999-00451

Box Contents



Exterior Assembly



Gasket

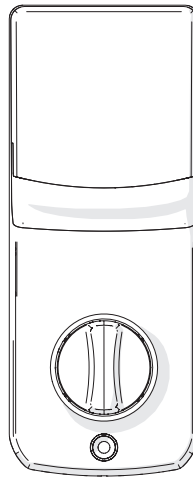

Interior Assembly

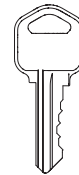

Key (2)



Screw Cover

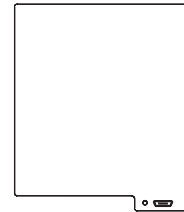

Rechargeable Battery

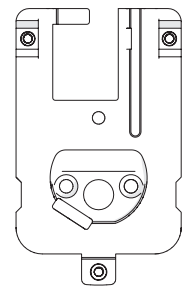

Interior Mounting Plate

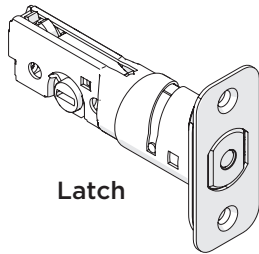

Latch

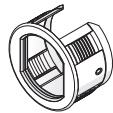

Drive-in Collar

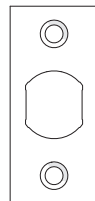

Square Corner Face Plate

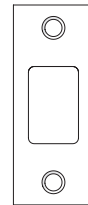

Strike Plate

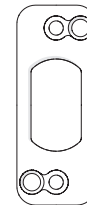

Reinforcement Plate

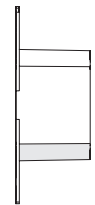

Dust Box (Optional)

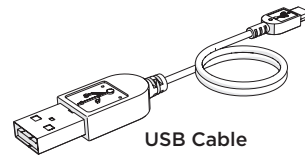
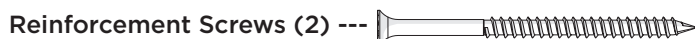
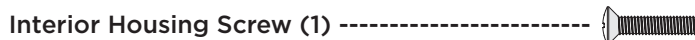

USB Cable

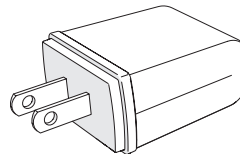

Wall Adapter

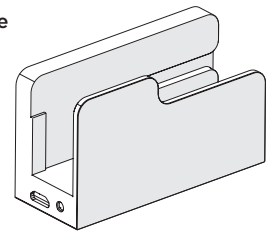

Battery Charging Cradle

Need help? Download the ARRAY™ app or visit www.arraylock.com for installation videos or call 1-800-850-LOCK (5625).

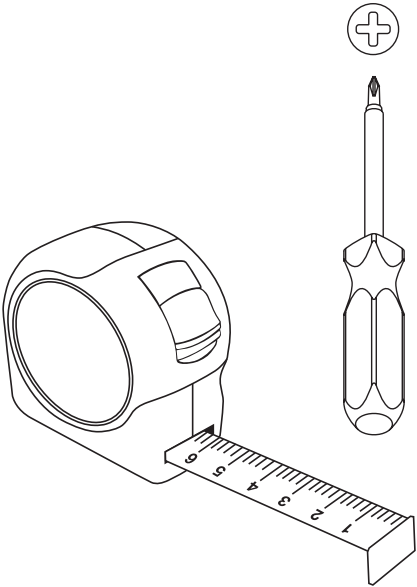
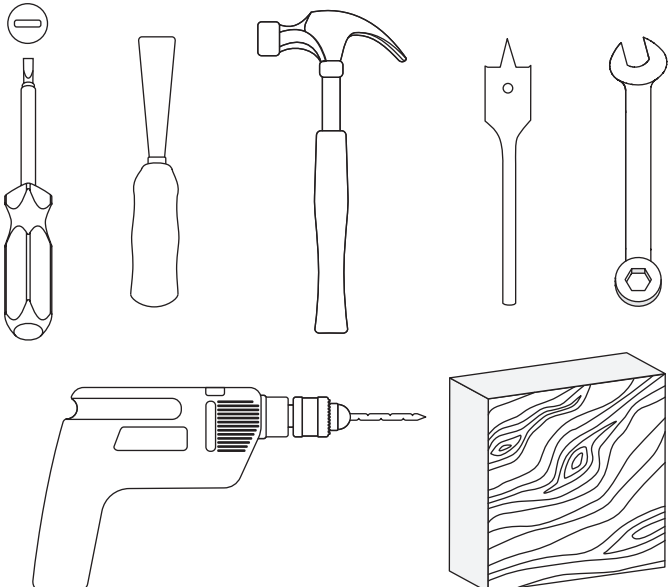
Tools you will need:	Tools you may need:
	

⚠ IMPORTANT INSTALLATION NOTES. PLEASE READ:

- Remove the battery from the battery compartment and charge it in the Charging Cradle until the LED turns green.
- The ARRAY™ lock has a built-in solar panel that will charge the battery if positioned in direct sunlight. If unable to position the lock in direct sunlight, you may need to charge the battery more frequently. You will see the battery status on the app.
- Do not attempt to disassemble any internal components of the lockset. You will void the warranty.
- Do not install the battery until you've installed the lock and downloaded the app. Follow the instructions in order.
- Do NOT use a power drill to install the lock. A power drill should only be used for door preparation.
- Make sure your door is properly aligned and can be closed without pushing, pulling or lifting the door.





Compatible Devices:

Note: New devices will continue to be added to enhance your experience with the ARRAY™ lock. Please visit our website www.arraylock.com for a complete list of compatible devices.

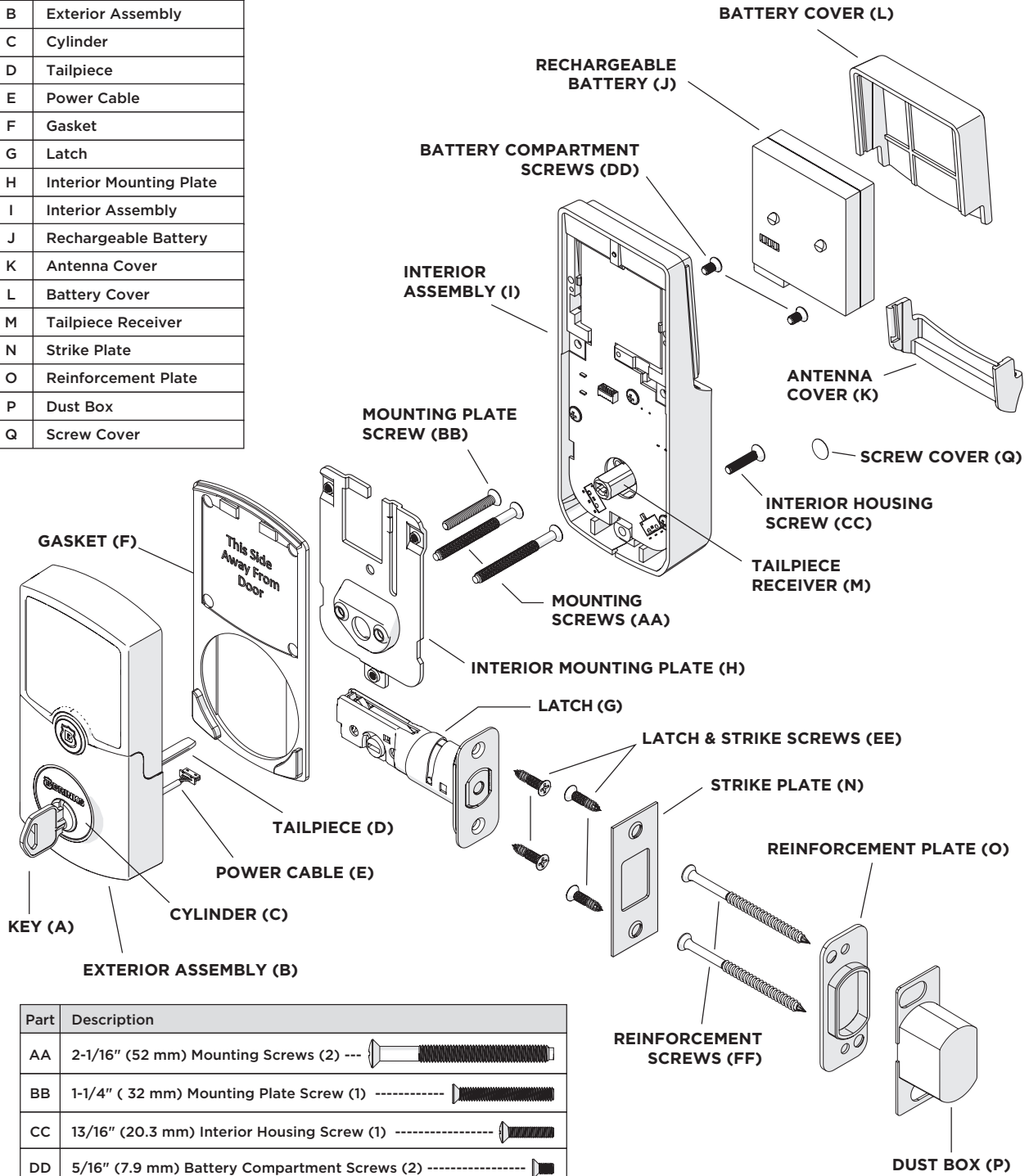
Installation Overview

Part	Description
A	Key
B	Exterior Assembly
C	Cylinder
D	Tailpiece
E	Power Cable
F	Gasket
G	Latch
H	Interior Mounting Plate
I	Interior Assembly
J	Rechargeable Battery
K	Antenna Cover
L	Battery Cover
M	Tailpiece Receiver
N	Strike Plate
O	Reinforcement Plate
P	Dust Box
Q	Screw Cover

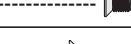

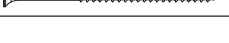
Part	Description
AA	2-1/16" (52 mm) Mounting Screws (2) --- 
BB	1-1/4" (32 mm) Mounting Plate Screw (1) ----- 
CC	13/16" (20.3 mm) Interior Housing Screw (1) ----- 
DD	5/16" (7.9 mm) Battery Compartment Screws (2) ----- 
EE	3/4" (19.2 mm) Latch & Strike Screws (4) ----- 
FF	3" (76.2) Reinforcement Screws (2) ---- 

Pre-Installation Instructions

1. Charge Battery

a. Remove the Battery Cover (L), Rechargeable Battery (J), Battery Charging Cradle, USB Cable and Wall Adapter. Remove the plastic tab on the Battery (J). Slide the Battery (J) into the Charging Cradle from the side. Charge the Battery (J) until the LED Light turns from red to green.

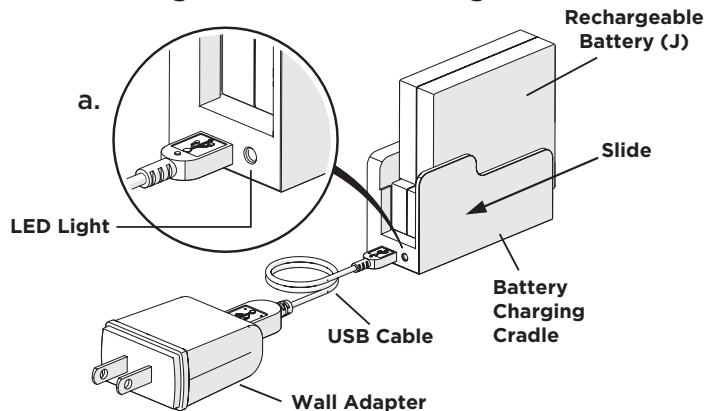

b. Carefully remove the Antenna Cover (K) by gently pulling the edges outward slightly and lifting.

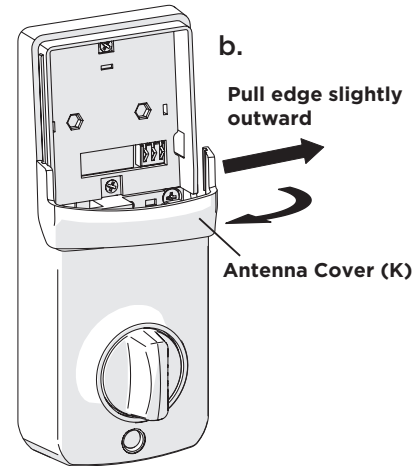

2. Watch the Installation Video



The ARRAY™ lock is compatible with either iOS® or Android™ devices. Search for “ARRAY™ Lock” at the App Store or Play Store to download the free app. Once the app is downloaded, register your lock and watch the installation video. Install your ARRAY™ lock (Steps 3 - 5) and then follow the instructions to add a lock or visit www.arraylock.com/pages/installation.

3. Prep the Door • FITS DOORS 1-3/8" (35 mm) TO 1-3/4" (45 mm) THICK •

- If replacing an existing deadbolt. Remove the old hardware and begin at **STEP 4**.
- If installing ARRAY™ on a new door, follow the door preparation instructions on **PAGE 9** and use the template provided on **PAGE 10**.

4. Install Latch and Strike Plate

Install Strike Plate (N) in the Door Frame

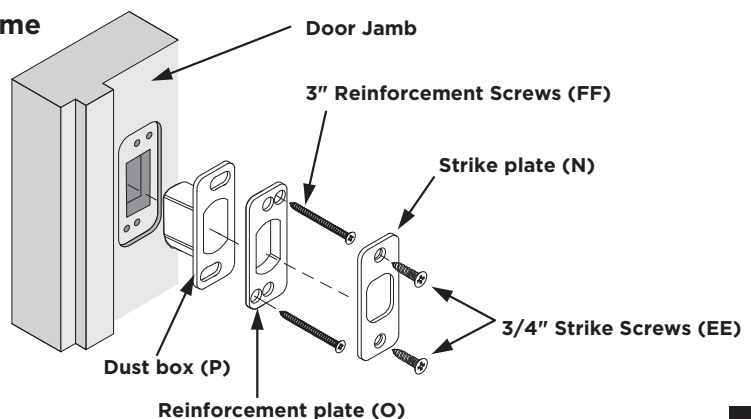

4. Install Latch and Strike Plate (Continued)

Determine the Proper Faceplate

Mortise on door edge chiseled:

a. Square corner faceplate

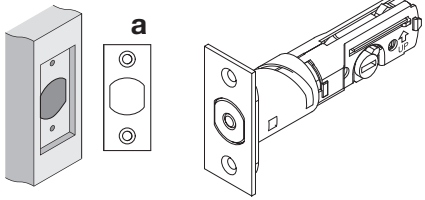

b. Round corner faceplate

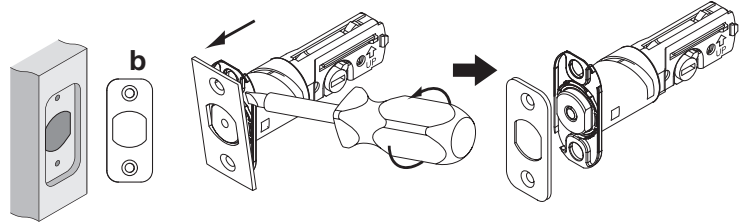

OR

Door edge not chiseled:

c. Drive-in collar option

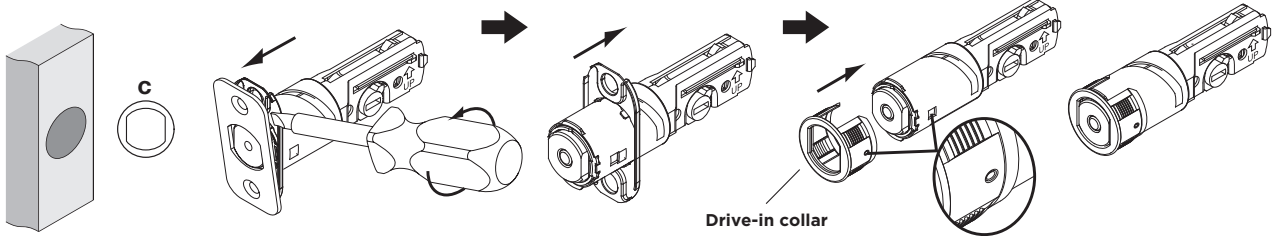

Set the Latch Backset

The distance from the center of the bore hole to the edge of the door is called the backset. If the backset of your door is 2-3/8", you don't need to adjust the latch. The backset is preset for 2-3/8".

If the backset of your door is 2-3/4", you'll need to adjust the latch as shown.

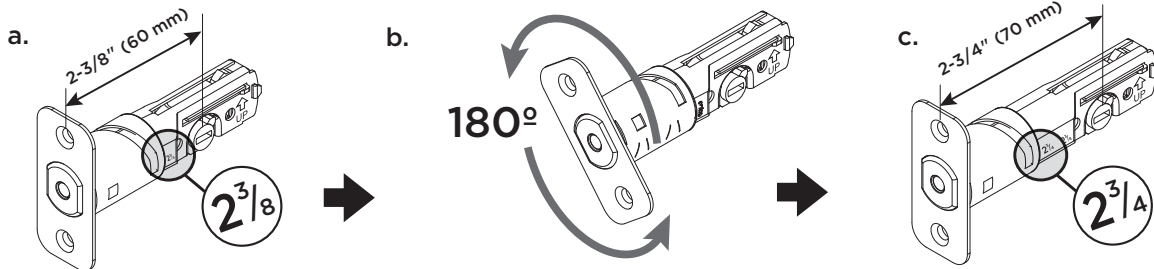

Install the Latch

CAUTION: Be sure the latch is in the upright position.

Option 1

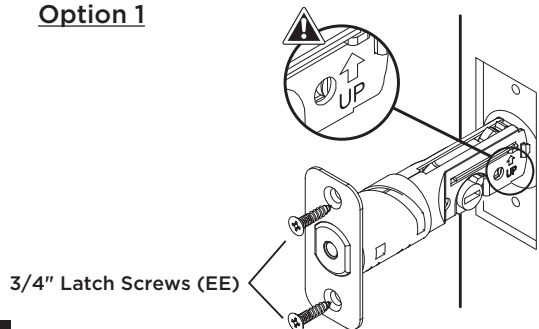

3/4" Latch Screws (EE)

Option 2

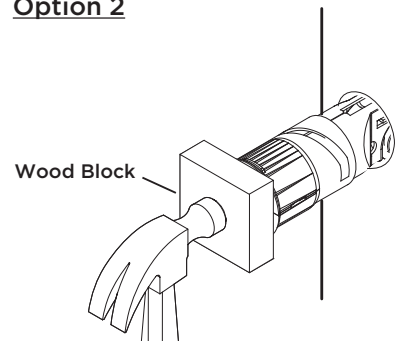

Wood Block

OR

Deadbolt Installation Instructions

5. Install Lock Assemblies

A. Door Bore Hole Options

Option 1

For door with bore hole 2-1/8" diameter proceed to STEP D.

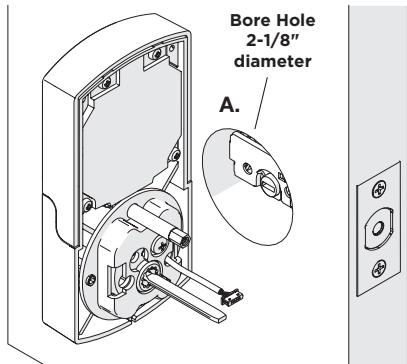

Option 2

For door with bore hole 1-1/2" diameter follow Steps B and C for Mounting Plate Screw (BB) and Mounting Plate removal.

OR

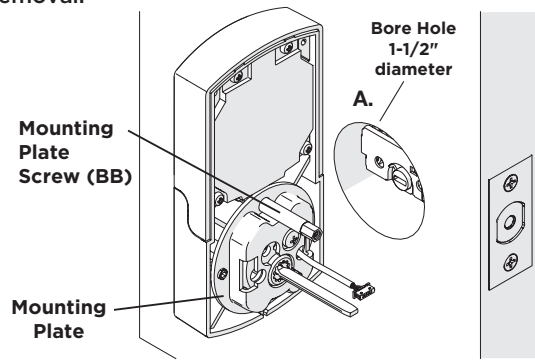

B. Remove Mounting Plate Screw

Use a wrench and in a counter-clockwise motion, remove the Mounting Plate Screw (BB).

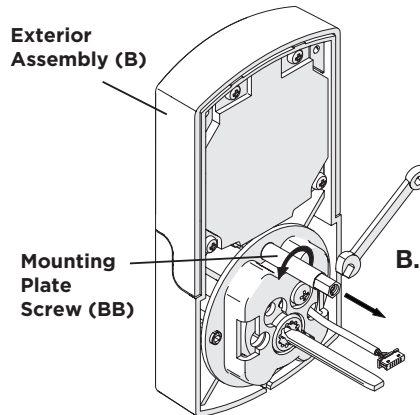

C. Remove Mounting Plate

Use a flathead screwdriver to remove the Mounting Plate.

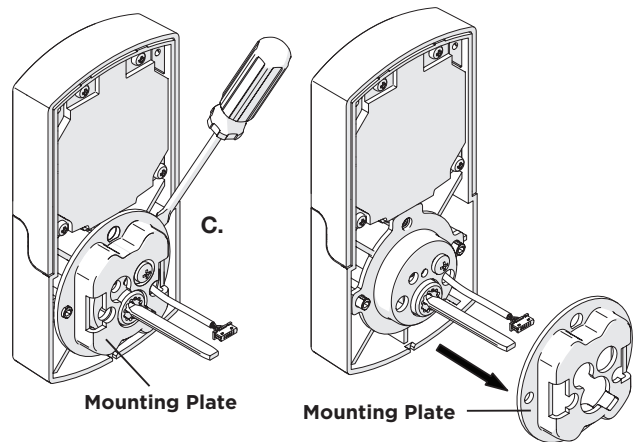

D. Apply Gasket

- ① Slide keypad cover up.
- ② Apply Gasket (F).
- ③ Slide keypad cover down.

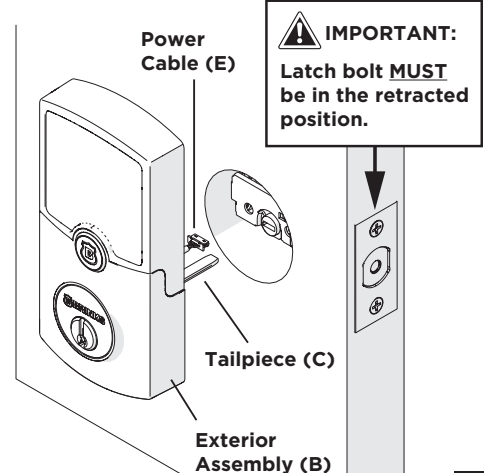
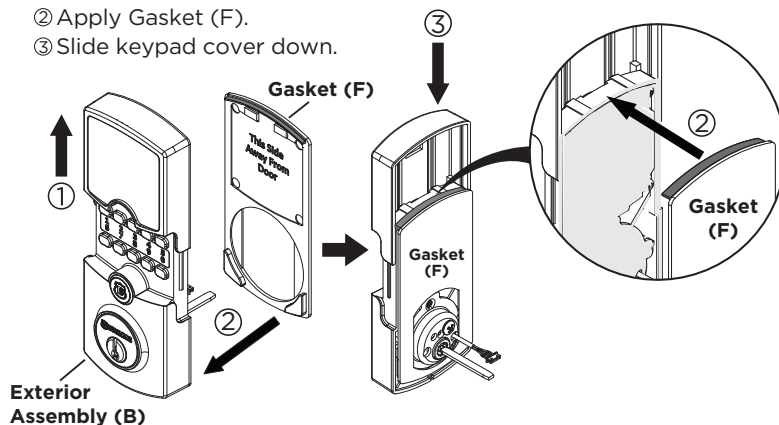

IMPORTANT:
Latch bolt **MUST**
be in the retracted
position.

5. Install Lock Assemblies (Continued)

E. Power Cable (E) goes underneath the latch. Insert Tailpiece (D) horizontally.

EXTERIOR VIEW

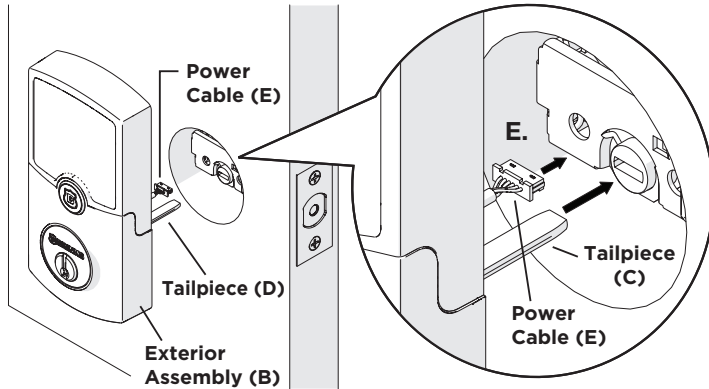

F. Bulged part of the Interior Mounting Plate (H) must be toward the door.

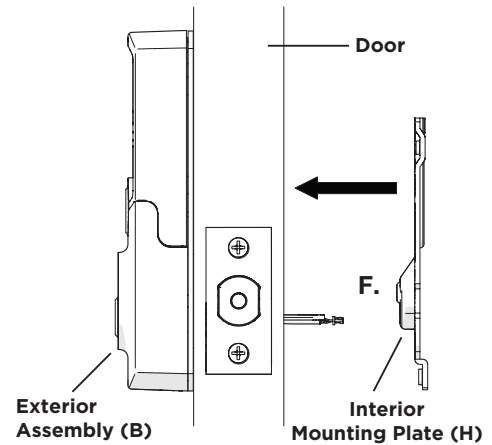

G. Feed Power Cable (E) through Interior Mounting Plate (H) as shown. Insert Mounting Screws (AA) and Mounting Plate Screw (BB) as shown and tighten.

INTERIOR VIEW

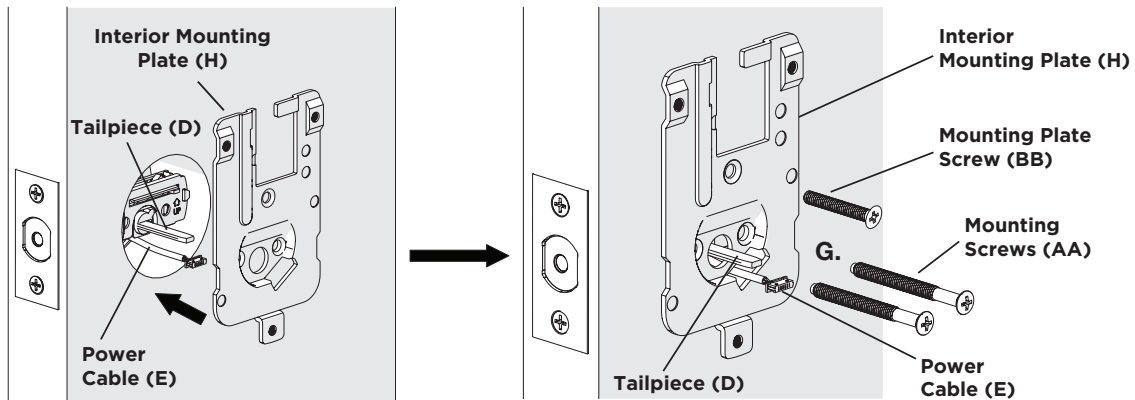

H. Install the Power Cable (E) firmly into the Connector Port.

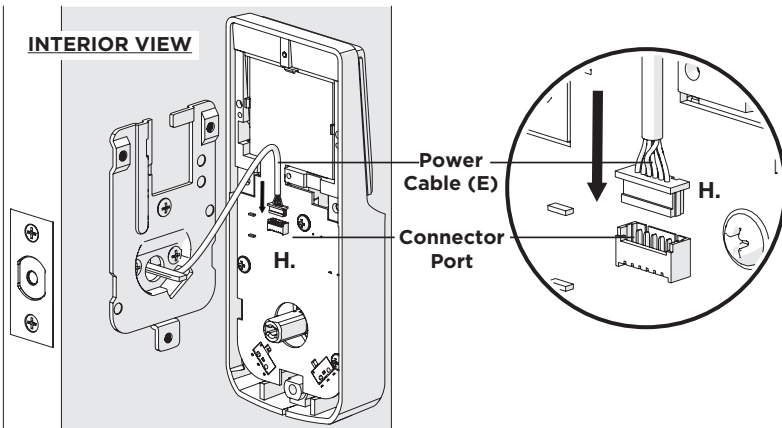

I. Secure the Power Cable (E) onto the Interior Mounting Plate (H) as shown.

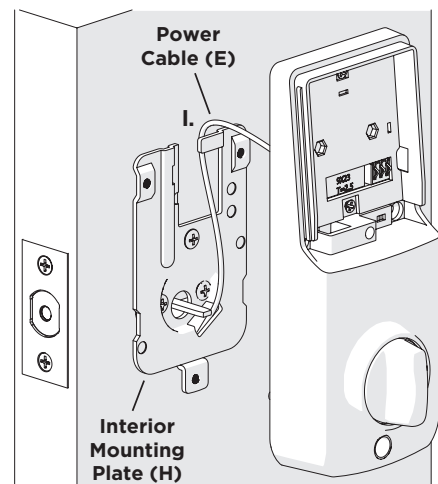

5. Install Lock Assemblies (Continued)

J. Align the Tailpiece Receiver (M) of the Interior Assembly (I) into the Tailpiece (D).

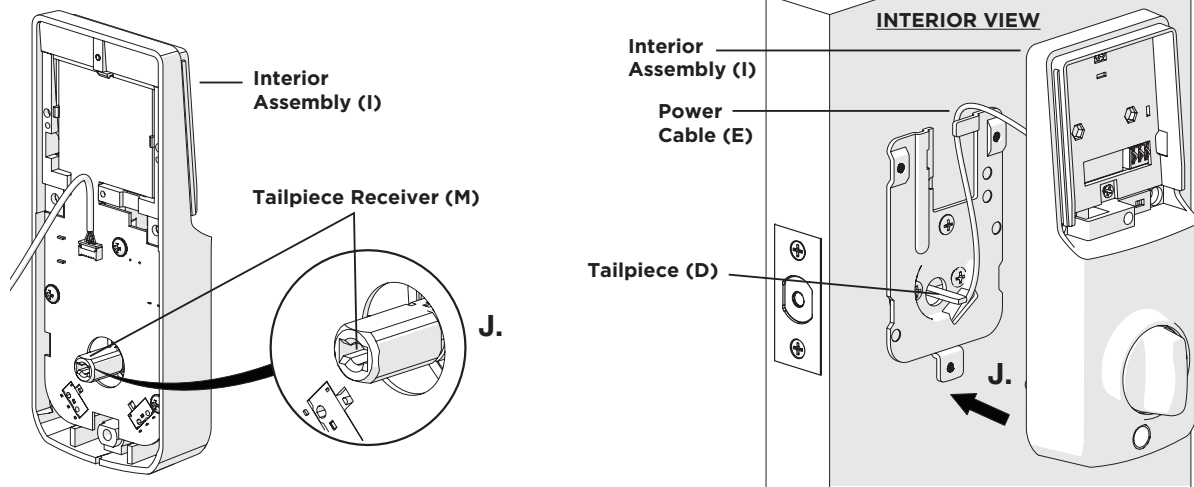

K. Insert the two Battery Compartment Screws (DD) and tighten. Insert the Interior Housing Screw (CC) and tighten.



CAUTION:

Take care not to damage the antenna when inserting the Battery Compartment Screws (DD).

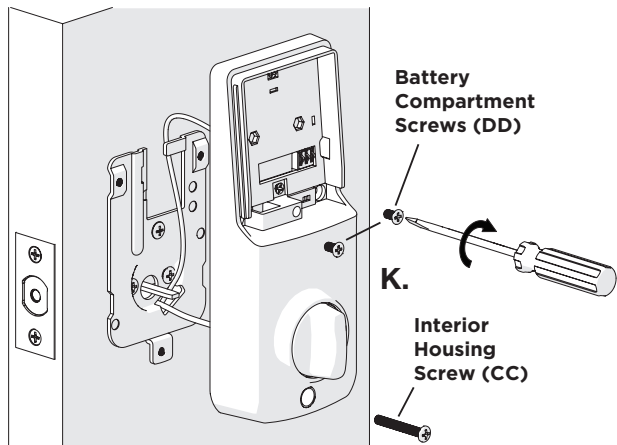

L. Re-install the Antenna Cover (K) by gently separating both sides of the Cover (K) and snapping the Cover (K) onto the side ridges of the Interior Assembly (I). Apply Screw Cover (Q).

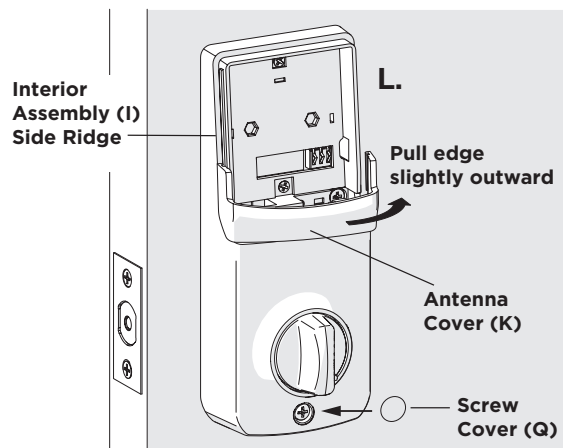

6. Return to the app and follow the instructions to Add a Lock

Door Preparation Instructions for New Doors

If installing ARRAY™ on a new door, follow the door preparation instructions and use the template on *Page 10*.

Mark Door with Template

- Mark the centerline for the deadbolt about 44" (1120 mm) from the floor, or about 5-1/2" (140 mm) above the center of an existing knob or lever.
- Apply the template to the door with the dotted fold line on the door edge.
- Select the 2-3/8" (60 mm) or 2-3/4" (70 mm) backset and mark the center for the hole for the deadbolt on the door face. (Most residential doors have a 2-3/8" backset.)
- Mark the center for the latch hole on the door edge according to the thickness of your door.

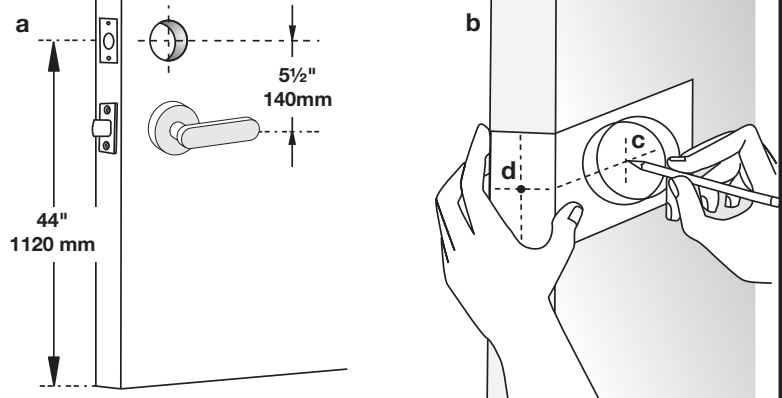

Drill Holes

- Drill a 2-1/8" (54 mm) hole on the door face from both sides to avoid splitting wood.
- Drill a 1" (25.4 mm) hole in the door edge for the latch.
- Insert latch into hole, mark outline of faceplate, and chisel 1/8" (3 mm) deep or until the faceplate is flush with the door edge.
- Mark latch screw holes and drill two 1/8" (3 mm) pilot holes for the Latch Screws.

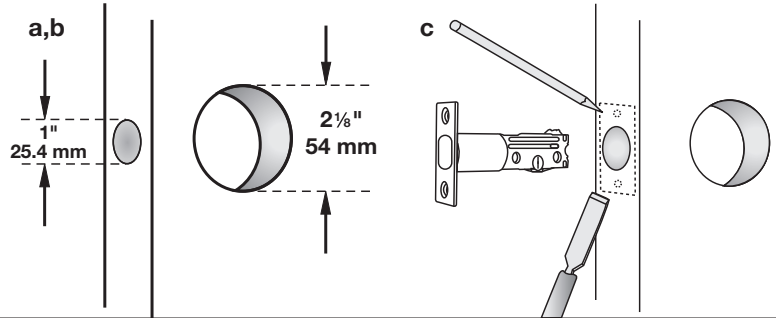

Prepare Door Jamb for Strike Plate

- Mark centerline on the door jamb exactly opposite the latch hole in the door edge. Make sure that the mark is correct so that the latch bolt will enter the strike plate without interference when the deadbolt is locked.
- Using the strike plate as a pattern, drill the latch and screw holes, and chisel out a mortise until the strike plate fits flush.

Door Jamb Hole Dimension

- 1-3/16" (30 mm)
- 1-9/16" (40 mm)
- 1" (25 mm)

Strike Plate Dimension

- 5/32" (4 mm)
- 2-3/4" (70 mm)
- 1-1/8" (28 mm)

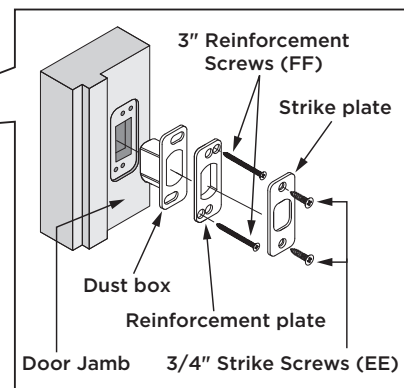
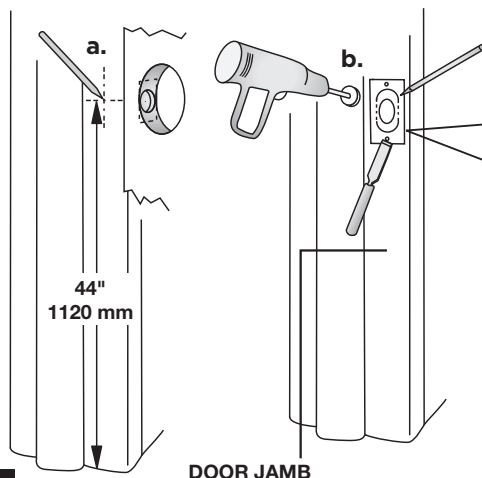
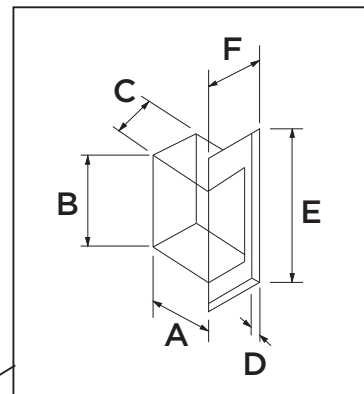

TEMPLATE

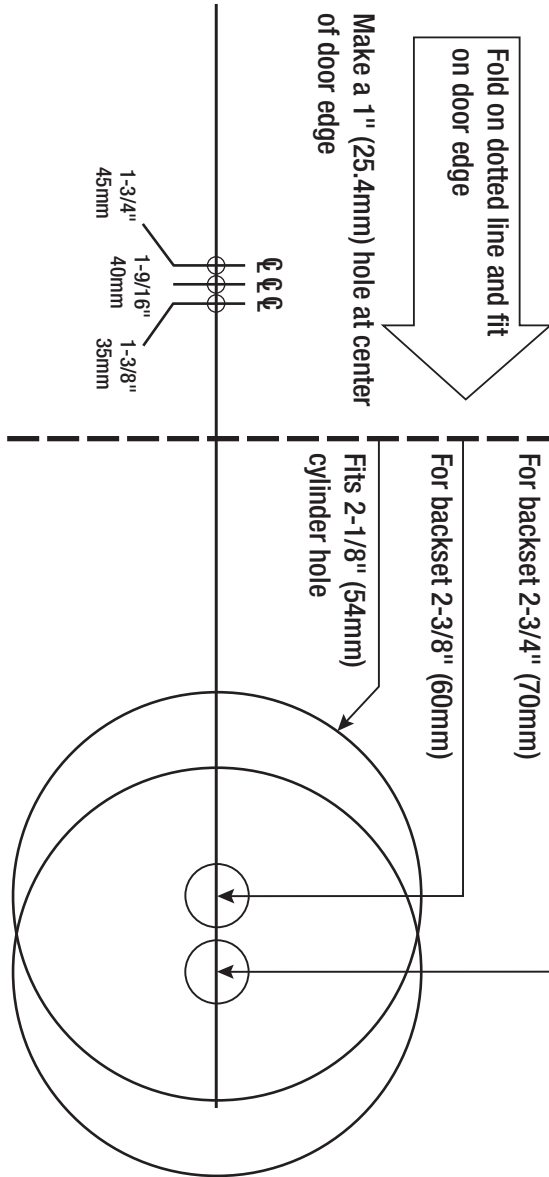

This line should be 3 inches. Measure it before using this template. If the line is not 3 inches when measured, print this instruction out, full scale on paper that is 8.5" x 11" and measure again.

ARRAY™ BATTERY MANUFACTURER'S INSTRUCTIONS

WARNING:

- Misusing the battery may cause it to get hot, explode, or ignite and cause injury. Follow the safety rules listed below:
 - Do not place battery in fire or heat the battery.
 - Do not penetrate the battery with nails, strike the battery with a hammer, step on the battery, or otherwise subject it to strong impacts or shocks.
 - Do Not Open, Crush, Heat Above 60°C (140°F), or Incinerate.
 - Do not solder directly onto the battery.
- Do not disassemble or modify the battery. The battery contains safety and protection devices which, if damaged, may cause the battery to generate heat, explode, or ignite.
- Do not place the battery on or near fires, stoves, or other high-temperature locations.
 - Do not place the battery in direct sun or use or store the battery inside hot conditions. Doing so may cause the battery to generate heat, explode, or ignite.
- Immediately discontinue use of the battery if, while using, charging, or storing the battery, it emits an unusual smell, feels hot, or appears abnormal in any other way.
- In the event that the battery leaks and the fluid gets into one's eye, do not rub the eye. Rinse well with water and immediately seek medical care. If left untreated, the battery fluid could cause damage to the eye.
- The temperature range for using the battery is -10°C to 60°C (14°F to 140°F). Use of the battery outside of this temperature range may damage the performance of the battery or may reduce its life expectancy.
- Do not use the battery in any device except the BRINKS HOME SECURITY ARRAY™ Smart Deadbolt.

FCC GENERAL STATEMENT

This device complies with part 15 of the FCC Rules. Operation is subject to the following two conditions: (1) This device may not cause harmful interference, and (2) this device must accept any interference received, including interference that may cause undesired operation.

This equipment has been tested and found to comply with the limits for a Class B digital device, pursuant to part 15 of the FCC Rules. These limits are designed to provide reasonable protection against harmful interference in a residential installation. This equipment generates, uses and can radiate radio frequency energy and, if not installed and used in accordance with the instructions, may cause harmful interference to radio communications. However, there is no guarantee that interference will not occur in a particular installation. If this equipment does cause harmful interference to radio or television reception, which can be determined by turning the equipment off and on, the user is encouraged to try to correct the interference by one or more of the following measures:

- Reorient or relocate the receiving antenna, or increase the separation between the equipment and receiver.
- Connect the receiver to a different outlet.
- Consult Hampton Products International Corporation or an experienced radio/TV technician for help.

Any changes or modifications not expressly approved by the party responsible for compliance could void the user's authority to operate the equipment (i.e. any changes or modification that may influence the specification of radio frequency relating to the Wi-Fi® is prohibited).

FCC ID Number: 2ANTYA2350X

Wi-Fi® is a required trademark of Wi-Fi Alliance®.

WARRANTY - Full Lifetime mechanical & finish warranty and limited one-year electronics warranty.

Subject to the terms and conditions of this warranty, Hampton Products Int'l Corp. ("Hampton") extends a full lifetime mechanical and finish warranty and a limited one-year electronics warranty to the original residential user ("Original User") of this product ("Product") against defects in material and workmanship as long as the Original User occupies the residential premises upon which the Product was originally installed. This warranty only applies to the Original User of Product. This Warranty is not transferable. Upon pre-authorized return of defective Product to Hampton, Hampton may repair or replace the Product with a new or refurbished product at Hampton's sole discretion.

What is NOT covered: The following costs, expenses and damages are not covered by the provisions of this limited warranty: (1) labor costs including, but not limited to, such costs for the removal and reinstallation of Product; (2) shipping and freight expenses required to return Product to Hampton; (3) failures, defects, or damage (including, but not limited to, any security failure or loss of data), caused by any third party product, service, or system connected or used in conjunction with the Product, and; (4) any other incidental, consequential, indirect, special and/or punitive damages, whether based on contract, warranty, tort (including, but not limited to, strict liability or negligence), patent infringement, or otherwise, even if advised of the possibility of such damages. Some states do not allow the exclusion or limitation of incidental or consequential damages, so the above exclusion or limitation may not apply to you. This warranty give you specific legal rights and you may also have other rights that vary from state to state.

The provisions of this Warranty do not apply to Product: (i) used in commercial applications; (ii) used in common area applications; (iii) used for purposes for which they are not designed or intended; (iv) which have been subjected to alteration, abuse, misuse negligence or accident; (v) which have been improperly stored, installed, maintained or operated; (vi) which have been used in violation of written instructions provided by Hampton; (vii) which have been subjected to improper temperature, humidity or other environmental conditions; (viii) which, based on Hampton's examination, do not disclose to Hampton's satisfaction non-conformance to the warranty. Additionally, the limited lifetime warranty **DOES NOT COVER** scratches, abrasions, or deterioration due to the use of paints, solvents or other chemicals, abuse, misuse, or Product used in commercial applications.

Additional terms: Hampton does not authorize any person to create for it any obligation or liability in connection with the Product. Hampton's maximum liability is limited to the original purchase price of the Product. No action arising out of any claimed breach of this warranty by Hampton may be brought by the Original User more than one (1) year after the cause of action has arisen.

Exclusions: Tuscan Bronze® finish is designed to improve over time and change in appearance, creating a living finish through daily use and, thus, finish discoloration is not applicable to the above warranty.

For assistance or specific warranty details and limitations information, please call 1-800-850-5625 in the U.S and Canada, or visit www.arraylock.com.



BRINKS HOME SECURITY and all related logos are trademarks or registered trademarks of Brink's Network, Inc., and are used with permission.



50 Icon, Foothill Ranch, CA 92610-3000 USA
email: info@hamptonproducts.com
www.arraylock.com | 1-800-850-5625
Made in Taiwan
©2017 Hampton Products International Corp.
999-00451_REVE 10/17