

HAN ACCESS POINT  
AP271  
Installation Guide



1. Introduction

The high performance and rugged AP271 supports IP67 standard for harsh outdoor environments, such as exposure to high and low temperatures, persistent moisture and precipitation, and electrical interfaces include industrial strength surge protection. The AP271 supports a maximum concurrent data rate of 1.267Gbps (867Mbps in 5GHz and 400Mbps in 2.4GHz), and dual Gigabit Ethernet links, integrated omni-directional antennas, it is ideal for medium density outdoor environments.

1.1. Package Contents

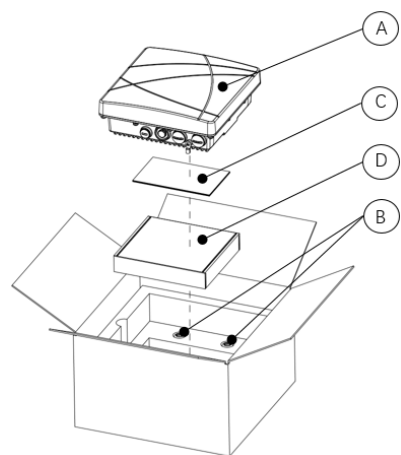

Figure 1

- A. AP271 - Outdoor Access Point (AP)  
B. Cable Gland x 2 pcs  
C. Documents:  
1) Installation Guide (this document)  
2) Quick Start Guide  
3) User Guide Info Card  
4) Regulatory Compliance and Safety Information  
D. Outdoor AP mounting kit package, which contains the following items

Table 1

Item	Description	Graphics	Qty
D1	Mounting bracket ( D1 )		1
D2	Mounting bracket ( D2 )		1
D3	Mounting bracket ( D3 )		1
D4	Spacing tube		1

Item	Description	Graphics	Qty
D5	Screw bolt M8 x 65		1
D6	Screw bolt M8 x 25		1
D7	Screw bolt M6 x 12		3
D8	Spring washer Φ8		2
D9	Spring washer Φ6		3
D10	Screw nut M8		2
D11	Locknut M8		2
D12	Hose clamp (102-152mm)		2
D13	Expansion bolt M6x60		4

NOTES :

- Component dimensions are in metric.
- The weatherproof caps for Ethernet and Console are connected to the AP, not loose in the package.
- Do not open or remove the Protective vents.
- Inform your supplier if there are any incorrect, missing, or damaged parts. If possible, retain the carton, including the original packing material. Use these materials to repack and return the unit to the supplier if needed.

1.2. Hardware Overview

- AP271 Front View

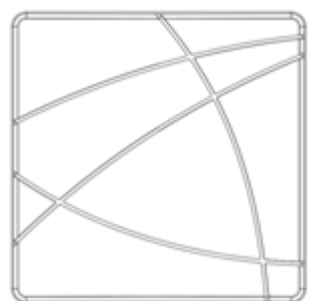

Figure 2

- AP271 Rear View

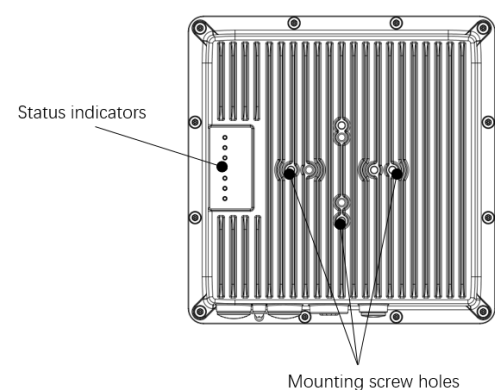

Figure 3

- AP271 Bottom View

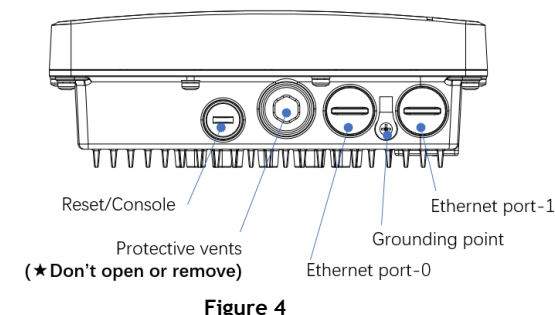

Figure 4

1.3. Pre-Installation Checklist

Before installing your AP271, be sure that you have the materials and tools listed below:

- IEEE 802.3af compliant PoE source.
- Gigabit Ethernet cable of required length and RJ45 connector.
- Grounding wire #8AWG of required length.
- Tools:

- Ratchet wrench
- Hexagon sockets
- Screw driver
- Rotary hammer
- Percussion bit Φ8
- Ratchet Crimping Plier for non-insulated terminal

- Crimping Tool for RJ45 Modular Plug
- Ethernet cable tester.
- Heat shrinkable tube
- Heat gun

1.4. Deployment Process Overview

The deployment of an Access Point typically consists of the following stages:

- WLAN Planning—The administrator determines how many APs will be needed for their wireless network strategy and where they will be deployed.
- AP Installation—Each AP can be physically installed at proper location. Each location should be as close as possible to the center of the intended coverage area and should be free from obstructions or obvious sources of interference.
- AP Configuration—The administrator defines the operational behavior for each AP, such as RF characteristics and security features.

NOTES:

- Installing the Outdoor Access Point requires professional training. The AP must be professionally installed by a qualified engineer familiar with WLAN system.
- For AP configuration information, please refer to the User Guide.

2. Installing the AP

2.1. Using the Mounting Kits

2.1.1. Assembling Access Point(A) with Mounting bracket(D1), to get Subassembly (E1)

2.1.1.1. Materials Preparation

Table 2

Item	Description	Graphics	Qty
A	Access Point AP271		1
D1	Mounting bracket ( D1 )		1
D7	Screw bolt M6 x 12		3
D9	Spring washer Φ6		3

2.1.1.2. Assembly Processes

Step-1. Connecting the AP(A) with Mounting bracket(D1)

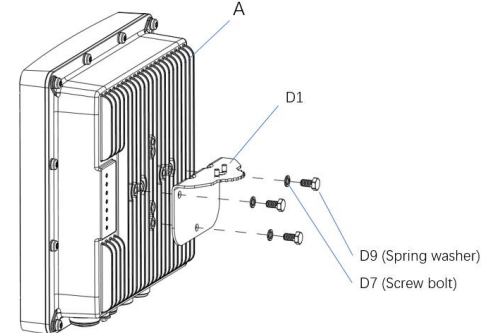

Step-1

Step-2. Get Subassembly (E1)

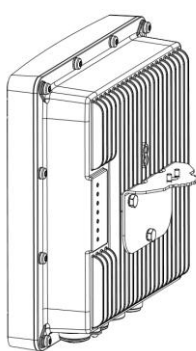

Step-2

Note :

- Must use a proper Ratchet wrench to tighten the Screw bolt(D7)

2.1.2. Assembling Mounting bracket(D2) with bracket(D3), to get Subassembly(E2)

2.1.2.1. Materials Preparation

Table 3

Item	Description	Graphics	Qty
D2	Mounting bracket ( D2 )		1
D3	Mounting bracket ( D3 )		1
D4	Spacing tube		1
D5	Screw bolt M8 x 65		1
D8	Spring washer Φ8		1
D10	Screw nut M8		1
D11	Locknut M8		1

2.1.2.2. Assembly Processes

Step-3. Insert the Mounting bracket (D2) into bracket (D3), and align Mounting bolt hole(A) with Mounting bolt hole(B).

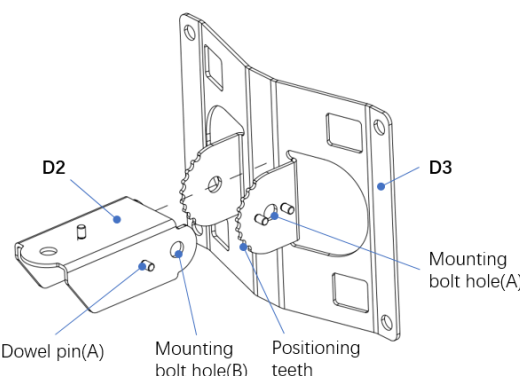

Step-3

Step-4. To get a required installation angle of pitch, adjusting the Dowel pin(A) on Bracket(D2) to match up with the Positioning teeth of Mounting bracket(D3)

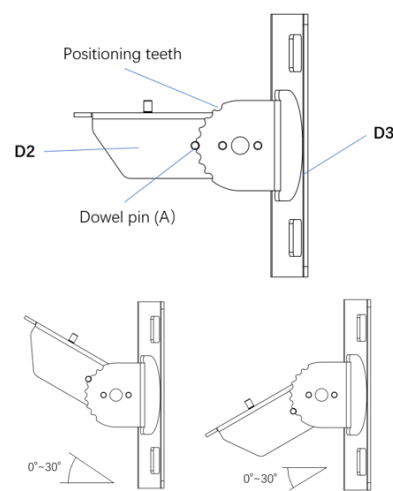

Step-4

Step-5. Insert the Spacing tube (D4) into bracket (D2), align the hole of the tube (D4) with the Mounting bolt hole (B) of bracket (D2).

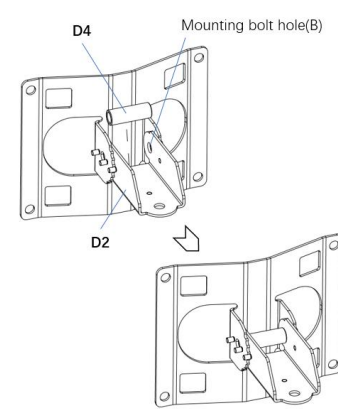

Step-5

Step-6. From the side of bracket (D3), where Dowel pin (B) stands, put the Screw bolt (D5) through

the Mounting bolt hole(A) and stick out at the other side. Make sure the Screw bolt goes through Mounting bracket(D3), bracket(D2) and Spacing tube(D4) in sequence. Then put a Spring washer (D8) and a Screw nut (D10) on it in sequence. Finally, tighten the Screw nut (D10) with ratchet wrench.

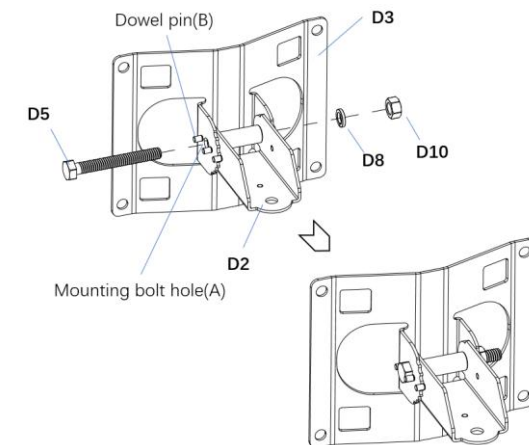

Step-6

Step-7. To prevent the screw nut from loosening and for better reliability, put a Locknut(D11) on the end of the Screw bolt(D5). Then tighten it up with ratchet wrench.

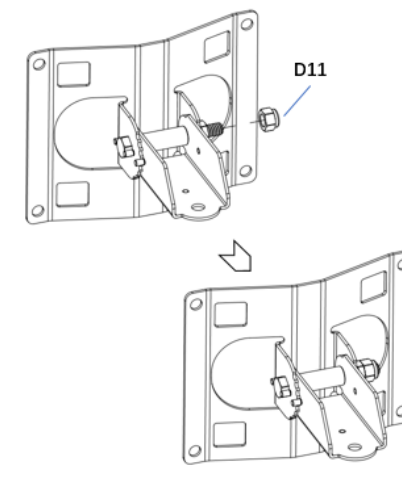

Step-7

Note :

- Must use a proper Ratchet wrench to tighten the Screw nut(D10) and the Locknut(D11)

Step-8. Get Subassembly (E2)

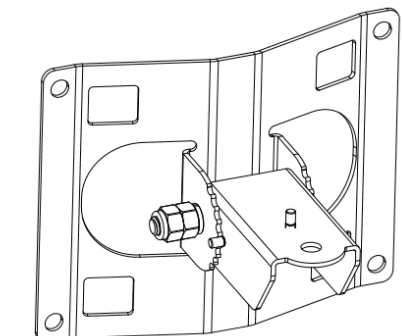

Step-8

2.1.3. Assembling Subassembly(E1) with Subassembly(E2), to get Final-Assembly (F)

2.1.3.1. Materials Preparation

Table 4

Item	Description	Graphics	Qty
E1	Subassembly ( E1 )		1
E2	Subassembly ( E2 )		1
D6	Screw bolt M8 x 25		1
D8	Spring washer Φ8		1
D10	Screw nut M8		1
D11	Locknut M8		1

2.1.3.2. Assembly Processes

Step-9. Overlap Subassembly (E1) to Subassembly (E2), align the Mounting bolt hole(C) with Mounting bolt hole(D).

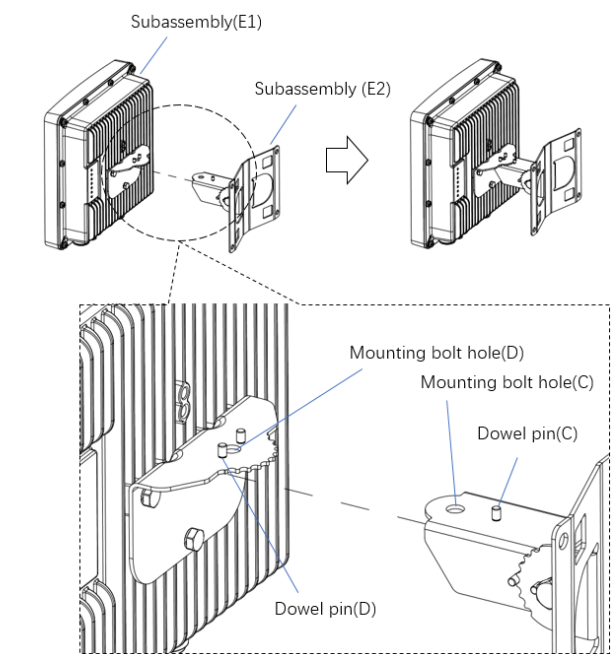

Step-9

Step-10. To get a required horizontal angle, adjusting the Dowel pin(C) on Bracket(D2) to match up with the Positioning teeth of Bracket (D1).

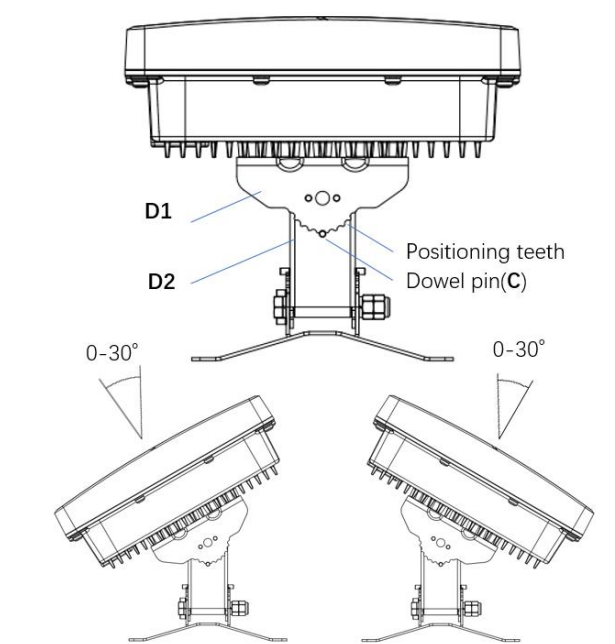

Step-10

Step-11. From the side of Bracket (D1), where Dowel pin (D) stands, put the Screw bolt (D6) through the Mounting bolt hole(D) and stick out at the other side. Make sure the Screw bolt goes through Mounting bracket(D1) and bracket(D2). Then put a Spring washer (D8) and a Screw nut (D10) on it in sequence. Finally, tighten the Screw nut (D10) with ratchet wrench.

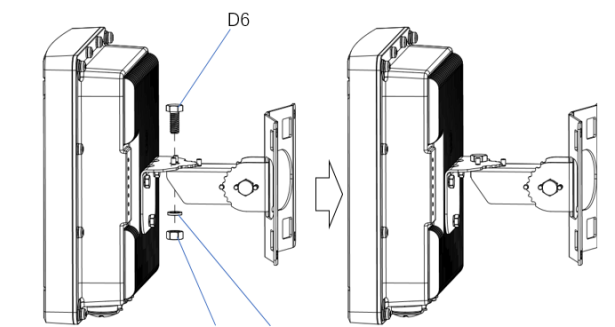

Step-11

Step-12. To prevent the screw nut from loosening and for better reliability, put a Locknut (D11) on the end of the Screw bolt(D6). Then tighten it up with ratchet wrench



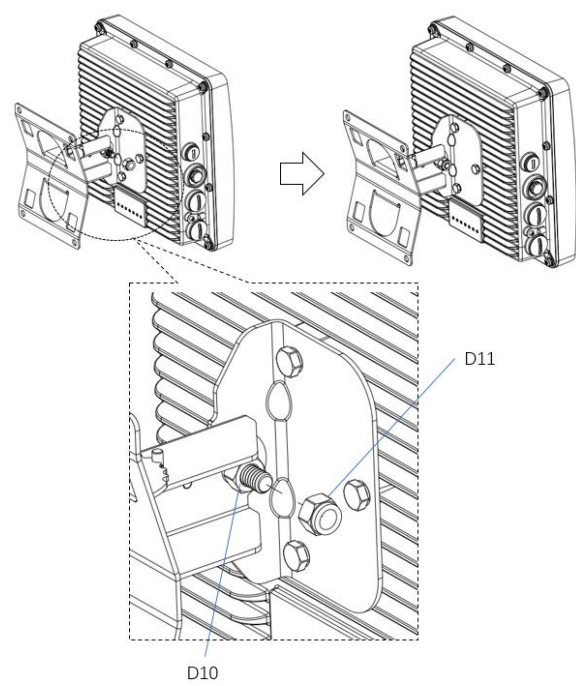

Step-12

Note :

- Must use a proper Ratchet wrench to tighten the **Screw nut(D10)** and the **Locknut(D11)**

Step-13. Final assembly (F)

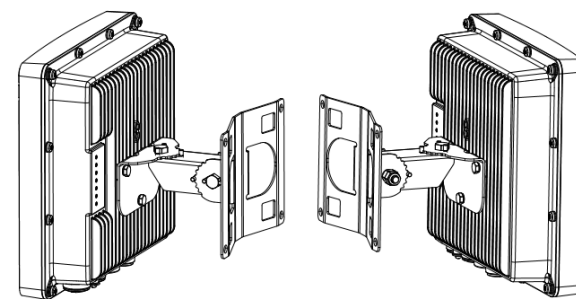

Step-13

## 2.2. Mounting the AP to a Pole or a Wall

The OmniAccess Stellar AP271 is for outdoor deployment, it can be mounted to a pole or a wall by using the accessories in the mounting kit package.

### 2.2.1. Pole Mounting

#### 2.2.1.1. Materials Preparation

Table 5

Item	Description	Graphics	Qty
F	Final assembly ( F )		1
D12	Hose clamp		2

#### 2.2.1.2. Mounting Processes

**Step-14.** Threading the **Hose clamps(D12)** through the **square mounting holes** in **bracket (D3)** separately. Considering your handedness, the direction of the **screw head** on the hose clamp should be determined before you thread.

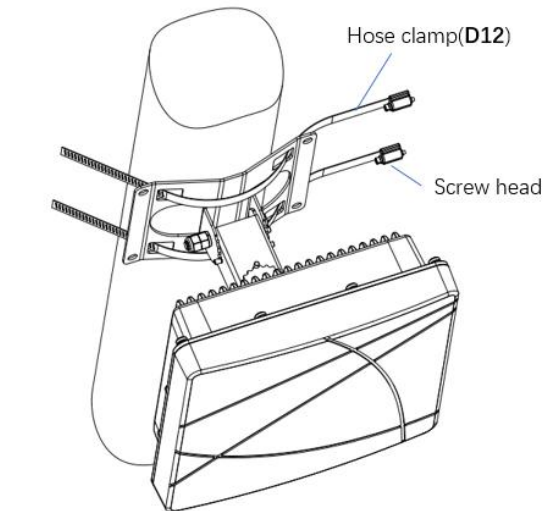

Step-14

### Step-15. Mounting to a pole

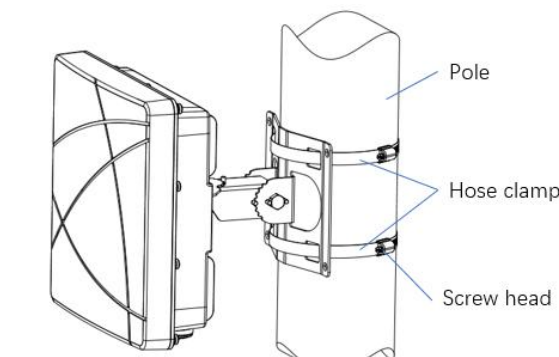

Step-15

Caution :

- Use caution to prevent hand injury!
- For safety, the **stencil area** in steel belt of the **hose clamps(D12)** should avoid overlapping the edge of square mounting holes on **bracket (D3)**.

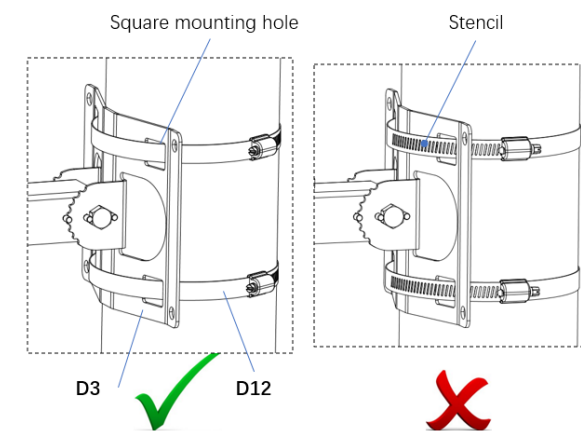

### 2.2.2. Wall Mounting

#### 2.2.2.1. Materials Preparation

Table 6

Item	Description	Graphics	Qty
F	Final assembly ( F )		1
D13	Expansion bolt M6 x 60		4

#### 2.2.2.2. Mounting Processes

**Step-16.** Draw four center marks on the wall where is planned to mount the outdoor AP. And then drill four  $\Phi 8 \times 45$  mm holes on the wall for expansion bolts.

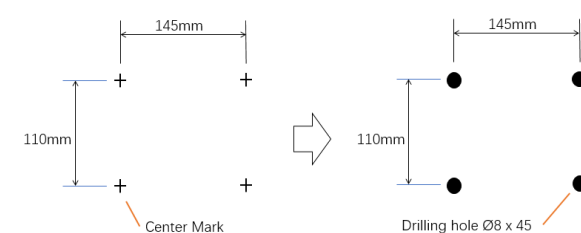

Step-16

**Step-17.** Insert 4 **Expansion bolts(D13)** into the holes on the wall separately. Make sure that the end of the **expansion tube** should be coplanar to wall surface.

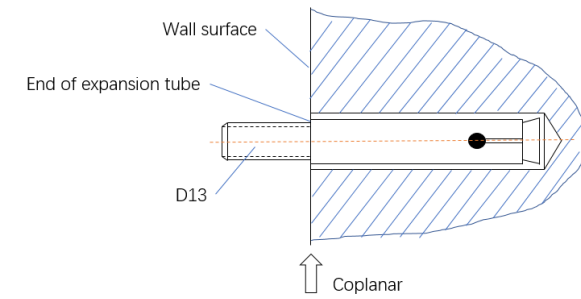

Step-17

**Step-18.** Put the 4 **expansion bolts** through the 4 mounting holes in **bracket(D3)**. Then put a **flat washer**, a **spring washer** and a **screw nut** on each expansion bolt in sequence. Finally, tighten the 4 screw nuts with ratchet wrench.

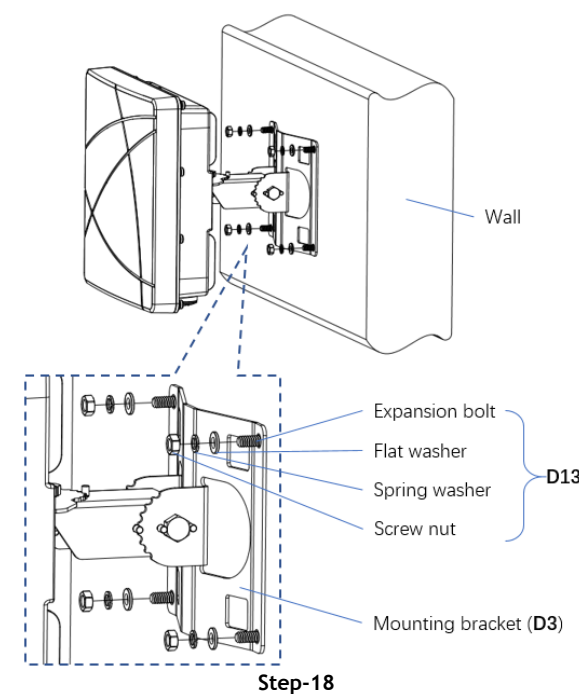

Step-18

## 2.3. Grounding the AP

Never forget to protect the AP by installing grounding wire. The grounding must be completed before powering up the AP.

### 2.3.1. Grounding Preparation

**Step-19.** Screw off the **O-Terminal** from the AP and keep it with the **Assembled bolt**.

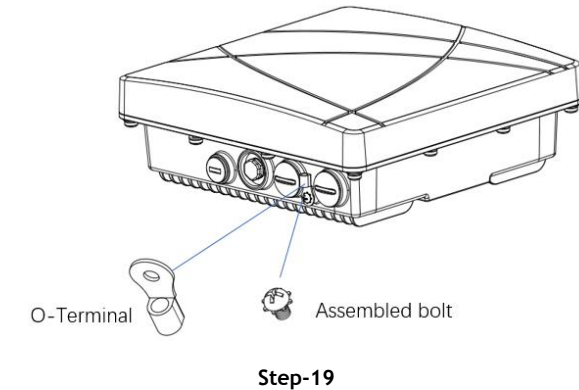

Step-19

### 2.3.2. Crimping the Grounding wire

**Step-20.** Peel the cover of one end of the grounding wire and place the bare grounding wire into the **O-Terminal**, and press firmly with the crimping pliers. A heat shrinkable tube is suggested to put on.

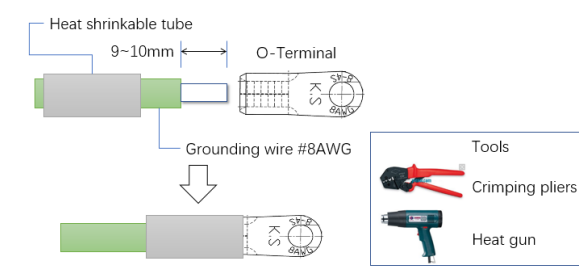

Step-20

### 2.3.3. Connecting the Grounding Wire

**Step-21.** Fasten the **O-Terminal** to the grounding hole on the AP with the **Assembled bolt**, take pole mounting circumstances for example as shown in figure (Step-21).

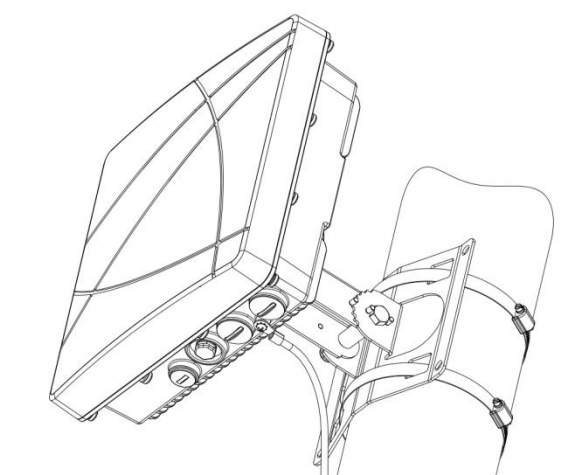

Step-21

## 2.4. Connecting the Ethernet Cable

To connect the Ethernet cable to the AP, perform the following steps using the **Cable glands(B)** that ships with your AP

### 2.4.1. The Cable Gland(B)

The **Cable gland(B)** is composed of 5 elements, which are **Sealing nut(B1)**, **Clamping ring(B2)**, **Seals(B3)**, **Gland body(B4)** and **O-ring(B5)**

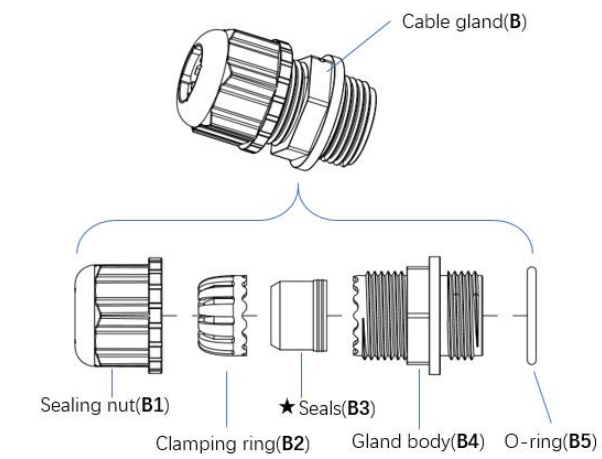

Cable gland(B) composition

★ The **Seals(B3)** inside the **Cable gland(B)** by factory default is applicable for cables with 4-6mm diameter. In the cable gland kit, another seals is provided for use with cable with 6-10mm diameter.

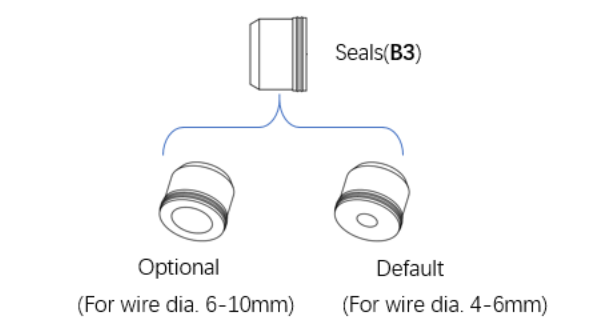

### 2.4.2. Crimping the Ethernet cable

**Step-22.** The following figure shows the process of crimping an Ethernet cable.

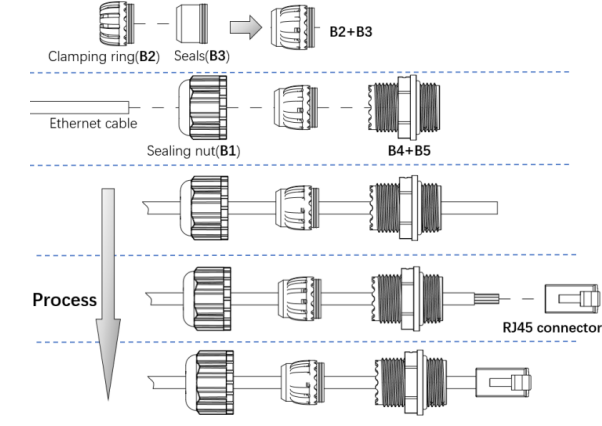

Step-22

Caution :

- Do Not peel the cover of the Ethernet cable or attach the RJ45 connector to the cable before sliding the **Cable gland(B)** over the cable.
- Failure to use the included Ethernet cable glands can lead to product issues.

### 2.4.3. Remove the Weatherproof Cap

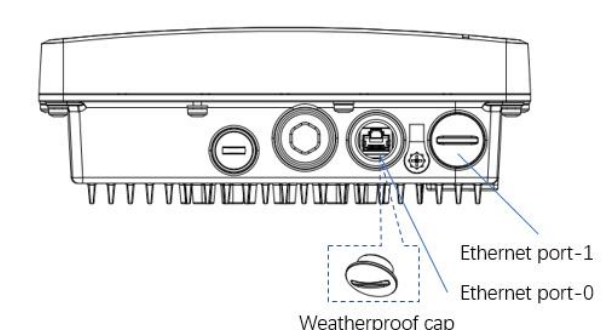

Note :

- Keep the weatherproof caps on the AP tightly while you don't plan to use the related ports.

### 2.4.4. Connecting the cable

**Step-23.** Connect the Uplink Ethernet cable, which will be powered up and was crimped in Step-22, to either Ethernet Port-0 or Ethernet Port-1. And then, screw the **Gland body(B4+B5)** onto the Ethernet port with proper wrench.

**Step-24.** Connect the **Seals with Clamping ring(B2+B3)** to the **Gland body(B4)**, and then screw the **Sealing nut(B1)** onto the **Gland body(B4)** and tighten it firmly.

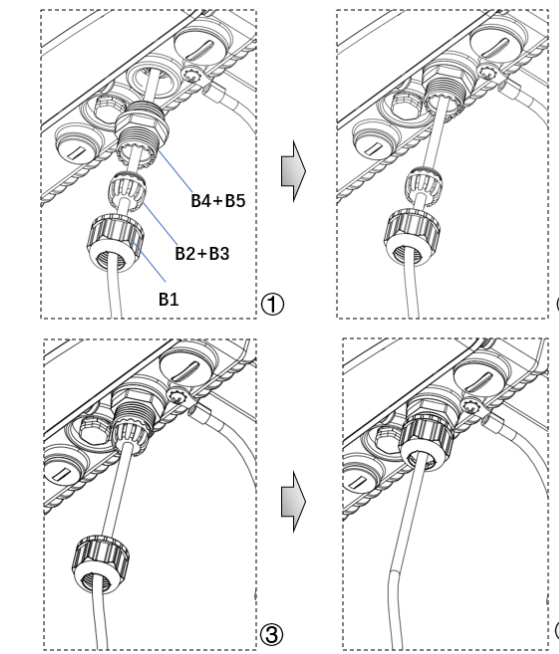

Step-23 & Step-24

Caution :

- Do not screw the **Sealing nut(B1)** onto the **Gland body(B4)** before connecting the RJ45 connector to the Ethernet port.
- Must use a proper wrench to tighten the Gland body.

### 2.5. Powering up the AP by PoE Source

**Step-25.** The AP271 supports IEEE 802.3af Compliant PoE source, accepting 48V DC(Nominal). A PoE injector as example is shown in the following figure.

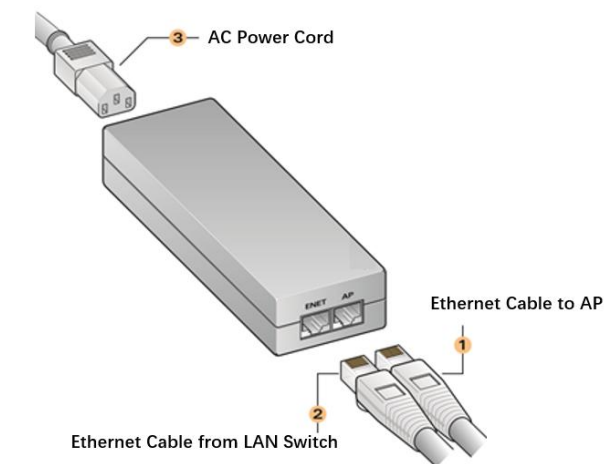

Step-25

## 3. Product Specifications

### 3.1. Dimensions/weight

- Single AP excluding packing box and accessories:  
243mm (W) × 243mm (D) × 85mm(H) / 2230g.

### 3.2. Interfaces

#### 3.2.1. Ports List

Table 7

Item Name	Description
✧ENET0	1x10/100/1000Base-T auto-sensing (RJ-45) port, Power over Ethernet (PoE)
✧ENET1	1x 10/100/1000Base-T auto-sensing (RJ-45) port, Power over Ethernet (PoE)
★Console Port	1x management console port (Micro-USB)
★Reset Button	Factory reset, for more information, refer to datasheet.

☆ Either ENET0 or ENET1 supports PoE source. If both ports are connected to PoE source, the PoE function will only be activated in the first connected port.

★ Screw off the smaller weatherproof cap on the left side in Bottom View of AP, you can see the Micro-USB console port and the reset button as shown in the following figure.

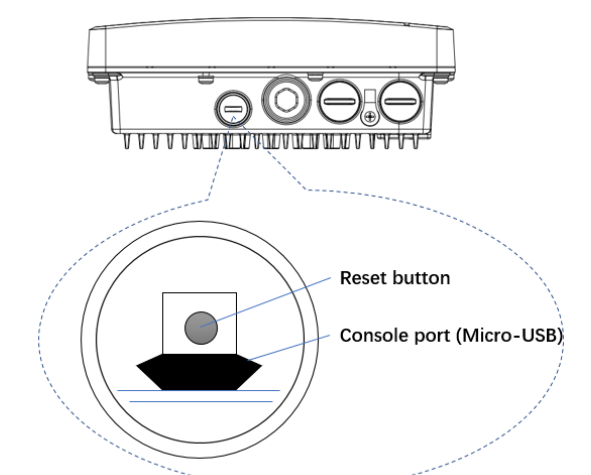

### 3.2.2. Ethernet Port Pin-outs

The Ethernet Ports of AP271 have RJ-45 female connectors with pin-outs shown in table 8.

Table 8

Ethernet Port / RJ45 Female	Pin	Signal Name	Function
	1	BI_DA+	Bi-directional pair +A, PoE Negative
	2	BI_DA-	Bi-directional pair -A, PoE Negative
	3	BI_DB+	Bi-directional pair +B, PoE Positive
	4	BI_DC+	Bi-directional pair +C, PoE Positive
	5	BI_DC-	Bi-directional pair -C, PoE Positive
	6	BI_DB-	Bi-directional pair -B, PoE Positive
	7	BI_DD+	Bi-directional pair +D, PoE Negative
	8	BI_DD-	Bi-directional pair -D, PoE Negative

### 3.3. Power

- Maximum (worst case) power consumption:  
<11.8W (802.3af PoE)

### 3.4. Environmental

- Protective level of enclosure: IP67
- Operating  
Temperature: -40°C to 65°C  
Humidity: 5% to 95% non-condensing
- Storage and transportation  
Temperature: -40°C to 85°C

For additional specifications on this product, please refer to the Data Sheet.