

# **NVR / Wi-Fi NVR User Manual**

2018-6

# 1 Important Safeguards and Warnings

## **Electrical safety**

Installation and operation should conform to your local electrical safety codes. We assume no liability or responsibility for any fires or electrical shock caused by improper handling or installation.

## **Transportation security**

Heavy stress, violent vibration or water splash should be avoided during transportation, storage and installation.

## **Installation**

Keep upright. Handle with care.

Do not apply power to the NVR before completing installation.

Do not place objects on top of the NVR

## **Qualified engineers needed**

All examination and repair work should be done by qualified service engineers.

We are not liable for any problems caused by unauthorized modifications or attempted repair.

## **Environment**

The NVR should be installed in a cool, dry place away from direct sunlight and inflammable or explosive substances, etc.

This product should be transported, stored and operated in the specified environments.

## **Accessories**

Be sure to use all the accessories available in the package.

Before installation, please open the package and check all the components are included.

Contact your local retailer if something is broken or missing in your package.

## **Lithium battery**

Improper battery use may result in fire, explosion, or personal injury.

When replacing the battery, please make sure you use the same model.

## **2 Declaration**

Please prevail in kind. The manual is for reference only.

This manual may contain inaccurate data or printing error.

The products described in this manual may be updated at any time.

Screenshots of the manual is not in a machine and only for display.

If in doubt, obtaining a copy of the latest procedure or the additional document, please contact with the company's after-sales department.

## TABLE OF CONTENTS

1 Important Safeguards and Warnings .....	2
2 Declaration .....	3
3 Product Introduction.....	1
3.1 Product Overview.....	1
3.2 Feature.....	1
4 Configuring the IP camera to work on the NVR .....	2
5 Optimize the WIFI performance.....	4
6 Read First .....	5
6.1 Remote Control .....	5
6.2 The Mouse.....	7
6.3 On-screen keyboard.....	7
6.4 Icon.....	8
6.4.1 The Screen Icons.....	8
6.4.2 Operation Icons .....	8
7 Installation .....	9
7.1 Unpacking Inspection.....	9
7.2 HDD Installation .....	9
7.3 Wi-Fi Camera Installation .....	9
8 Basic Operations Guide .....	10
8.1 Power On/Off.....	10
8.1.1 Power On.....	10
8.1.2 Power Off (Shutdown).....	10
8.1.3 Restart .....	11
8.1.4 Power recovery .....	11
8.2 Start-up Wizard .....	11
8.3 The right-click Menu.....	13
8.3.1 The screen Switching.....	14
8.3.2 Wireless Setting.....	14
8.3.3 P/T/Z .....	15
8.3.3.1 PTZ Configuration .....	15
8.3.3.2 Quick Location .....	16
8.3.4 Color Setting.....	16
8.3.5 Search.....	17
8.3.6 Manual Control .....	17
8.3.7 Channel Manage .....	18
8.3.8 The Main Menu.....	19
8.3.9 Live Preview.....	20
8.3.9.1 Channel Toolbar.....	20
8.3.9.2 Task Toolbar.....	21
9 Local Configuration .....	24
9.1 The Introduction of the Main Menu .....	24
9.2 Device Operation .....	25
9.2.1 Search (The Video Inquiry).....	25

9.2.1.1	Normal Search .....	26
9.2.1.2	Tag Search.....	29
9.2.1.3	Smart Search.....	30
9.2.2	Backup.....	31
9.2.3	Shutdown .....	32
9.3	Info Service .....	33
9.3.1	System .....	33
9.3.2	Disk.....	33
9.3.3	Event.....	34
9.3.4	Log.....	35
9.4	Device Config .....	36
9.4.1	Channel .....	36
9.4.1.1	Channel Manage .....	36
9.4.1.2	Advanced .....	37
9.4.1.3	Add IP Cameras .....	38
9.4.1.4	Modify channel configuration.....	39
9.4.1.5	Configure Front Device .....	39
9.4.1.6	Basic Setting .....	43
9.4.1.7	Encode Setting.....	44
9.4.1.8	Snapshot.....	44
9.4.1.9	P/T/Z.....	45
9.4.2	Network.....	46
9.4.2.1	Basic .....	46
9.4.2.2	Wireless Setting .....	47
9.4.2.3	Application.....	47
9.4.3	Alarm.....	48
9.4.3.1	Video Detection Configuration .....	48
9.4.3.2	Alarm Input.....	49
9.4.3.3	Abnormality .....	50
9.4.4	Storage .....	51
9.4.4.1	HDD Manage.....	51
9.4.4.2	Basic .....	52
9.4.4.3	Recording plan .....	53
9.4.5	System Configuration .....	54
9.4.5.1	Basic setting.....	54
9.4.5.2	Display Output.....	55
9.4.5.3	Maintain .....	56
9.4.5.4	Account.....	56
9.4.5.5	Default .....	58
9.4.5.6	Upgrade.....	58
9.4.6	APP Center .....	59
9.4.6.1	DDNS .....	59
9.4.6.2	Email.....	61
9.4.6.3	P2P.....	61

	9.4.6.4	Cloud Storage .....	62
	9.4.6.5	Push.....	62
10	WEB Access.....		63
	10.1	WEB Operation .....	63
	10.1.1	Network Connection.....	63
	10.1.2	The control installation and the user login logout.....	63
	10.1.3	The Interface of Web Operations.....	64
	10.1.4	Configuration .....	68
	10.1.5	Search Record .....	68
	10.1.6	Alarm Configuration.....	70
11	Appendix.....		72
	11.1	Alarm linkage setting .....	72
	11.1.1	Alarm Out.....	72
	11.1.2	Linkage Record.....	72
	11.1.3	Snapshot .....	73
	11.1.4	PTZ Linkage .....	73
	11.1.5	Tour .....	73
	11.1.6	Show Message .....	73
	11.1.7	Buzzer.....	74
	11.1.8	Send Email .....	74
	11.1.9	Server Push .....	75
	11.1.10	Send NetDisk.....	75
	11.2	Port Mapping.....	76
	11.2.1	UPNP Function .....	76
	11.2.2	Port mapping Manually.....	77
	11.3	Voice Intercom.....	78
	11.3.1	Summarize .....	78
	11.3.2	Configuration .....	78
	11.4	HDD S.M.A.R.T.....	78
	11.5	Hard disk problem .....	80
	11.6	HDD Capacity Calculation.....	82
	11.7	Terms .....	83
	11.8	FAQ .....	84

# 3 Product Introduction

## 3.1 Product Overview

This kit is a high performance network video recorder system, combined with H.265 video compression, high-capacity hard disk storage, TCP / IP transmission, embedded Linux operating system and a variety of other advanced technologies in the electronic information industry, all those ensure that a high-quality, low bit rate video storage characteristics, and good system stability.

This product complies with GB 20815-2006 standard video security surveillance digital video recording promulgated by the State.

This series product support local preview, multiple-window display, recorded file local storage, remote control and mouse shortcut menu operation, and remote management and control function. recording, playback, monitoring, synchronization of audio and video. Besides, the products support advanced control technology and strong network data transmission capacity.

## 3.2 Feature

### **Real-time monitoring**

Have a composite video signal interface and support TV, VGA or HDMI output simultaneously.

### **Compression function**

Using H.264/H.265 video compression standard and G.711 audio compression standard, can realize high definition, low code rate of the video coding to decrease the amount of data to save to HDD storage.

### **Recording function**

Support timing alarm linkage, motion detection, and other recording modes. Support SATA hard disk and local hard disk S. M.A.R.T technology. Support USB backup and network backup.

### **Video playback function**

You can search videos, within the local and network, by using the playback interface. As well as this it supports multiple videos playback, fast playing, slow playing and frame-by-frame playback. Video playback can be displayed the exact time of the incident using a graphical timeline to allow you to search for event footage much more efficiently.

### **Camera control and alarm**

Remotely installed cameras can be controlled and various alarm devices can be connected to ensure that you know when an event has been detected, The NVR integrates Motion Detection, Video Loss, Video Block, multiple alarm output and scene lighting control into its controller options.

### **Communication Interface**

Equiped USB 2.0 high-speed interface to allow for external video backup devices. Equiped the standard Ethernet interface port (plug and play).

### **Network functions**

Support

- TCP / IP
- UDP
- RTP / RTSP
- DHCP
- PPPOE
- DDNS
- NTP
- P2P

Also support real-time network monitoring, video playback, remote control and management functions. The built-in WEB Server allows you to directly access the NVR through a web browser.

### **Operation Mode**

You can operate by the NVR's front panel or using a mouse. A simple, intuitive graphical interface is provided for intuitive operation.

### **Intelligent Search**

You can search video by the intelligent analysis, such as face image retrieval through face detection data, or through the perimeter video analysis data to achieve event retrieval.

## **4 Configuring the IP camera to work on the NVR**

If you are trying to connect a Wi-Fi camera to the NVR, which is a new one out of the kit, then you will need to manually setup the camera so that it can be used on the system.

Follow the steps below to successfully configure and setup Wi-Fi camera with the NVR:



- 1) Power on the NVR and WIFI camera, then take the network cable out of the accessories box, and connect camera and NVR via this cable.

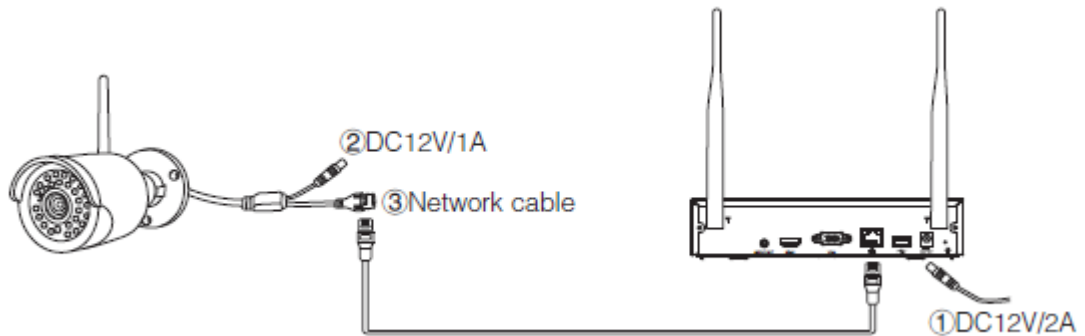

 The light of NVR on the wan port interface should be on, if the light is off, then can't match code, please check if the cable or device can work well or not.

- 2) Go to menu [MAIN MENU] > [Wireless Setting], click match button **Auto-Pair** to match code.

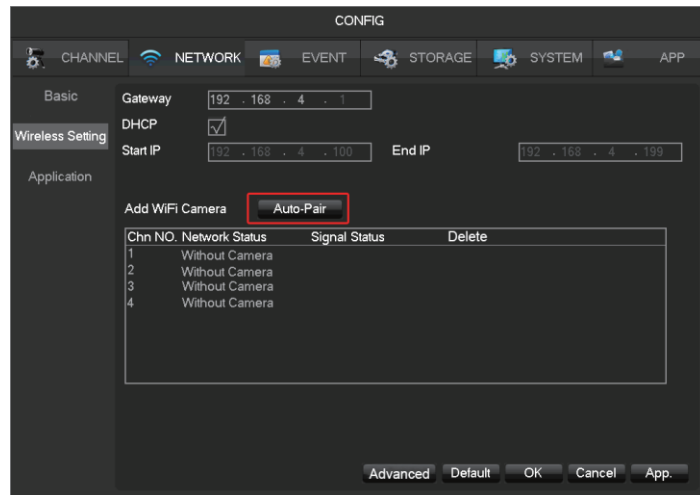

- 3) If match code successfully, the network status will show "OK" and video coming out. Then you can disconnect the network cable.

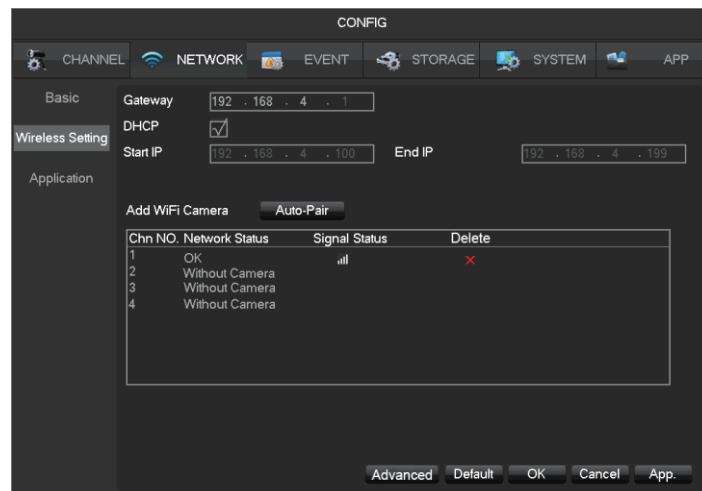

## 5 Optimize the WIFI performance

- 1) The signal coverage of antenna is similar to a round circle. Antenna located in center of the round circle, signal of surrounding is much stronger, but much weaker if antenna endpoints backoff direction. According to the signal divergency characteristics of antenna, and in order to guarantee the video quality, IPC antenna should try to keep in parallel with NVR antenna.

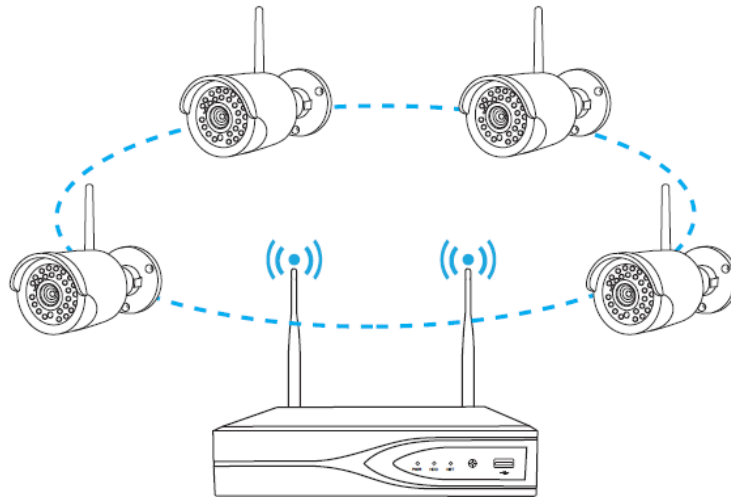

- 2) If the distance between IPC and NVR is too far, the signal is not strong enough, you can take off the original antenna and substitute antenna extension cord, then put it where WIFI signal is strong.

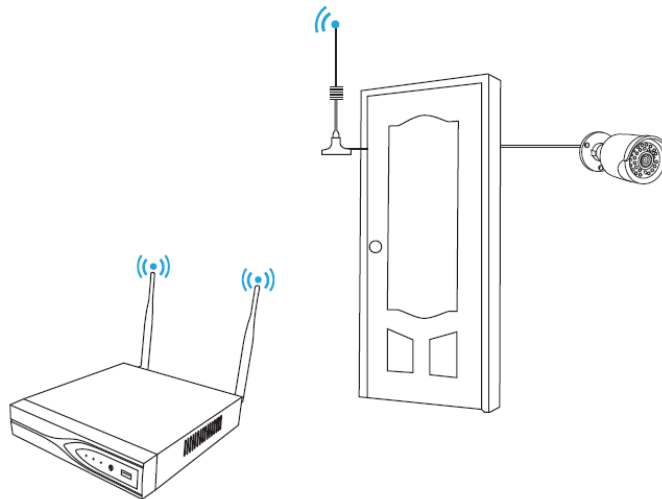

# 6 Read First

## 6.1 Remote Control

The remote control interface is shown as below:

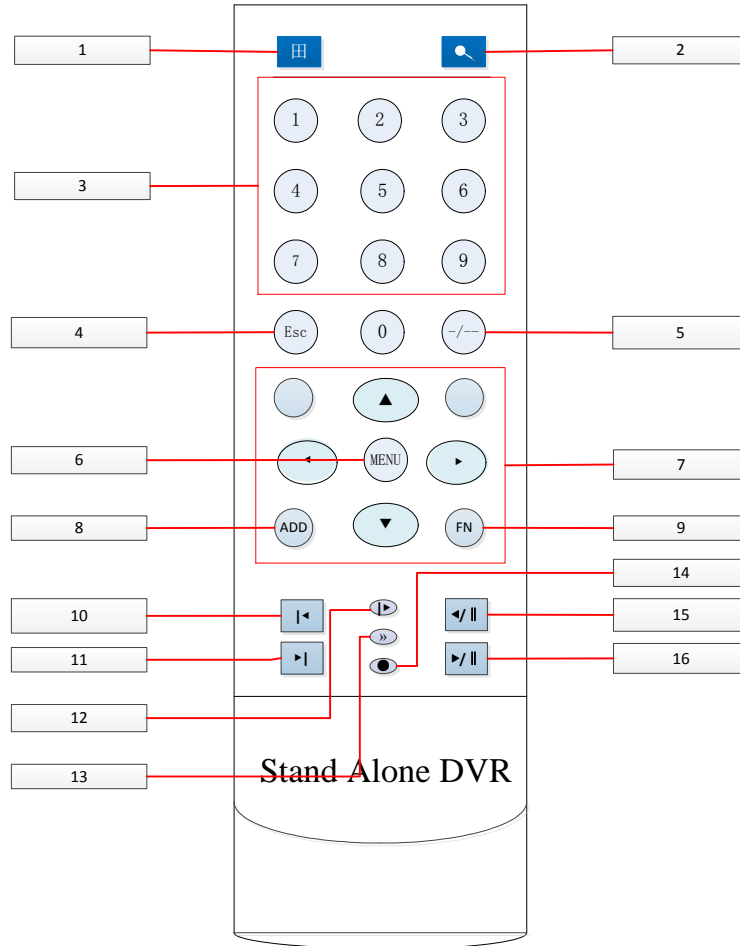

No.	Icon	Name	Description
1	田	Multiple-Window Switch	Switch between multiple-window and one-window.
2		Search	Access into the recording search menu.
3	1-9	Number Key	1. Input numbers (in number mode) 2. Input English character (in English mode) 3. Switch channel (one-window mode) 4. Input the password.
4	Esc	ESC	1. Go to previous menu 2. Cancel current operation.
5	-/--	Digital Switch	Enter a digital larger than 10, press two-digit number: 1. Press the tens digit; 2. Press digital switch button; 3. Press ones digit.

6	MENU	Confirm/Menu Key	<ol style="list-style-type: none"> <li>1. Confirm current operation;</li> <li>2. Go to OK button;</li> <li>3. Go to menu.</li> </ol>
7	▲	Up	<ol style="list-style-type: none"> <li>1. Assistant function such as PTZ menu;</li> <li>2. In monitor mode, switch between multiple-window and one-window;</li> <li>3. Activate the digital input box increase or decrease the number;</li> <li>4. Active pull-down menu to switch the drop-down box options;</li> </ol>
	▼	Down	<ol style="list-style-type: none"> <li>5. Activate checkbox to change status;</li> <li>6. Activate the text input box and step down carry and abdication;</li> <li>7. Activate the control box to move the slider;</li> <li>8. Activate display window to select the previous channel, next channel.</li> </ol>
	◀	Left	<ol style="list-style-type: none"> <li>1. Shift current activated control, and then move left and right;</li> <li>2. In monitor mode, switch channel;</li> </ol>
	▶	Right	<ol style="list-style-type: none"> <li>3. Assistant function such as PTZ menu.</li> </ol>
8	ADD	Remote Address	Click it to input device number, so that you can control it.
9	FN	Auxiliary Key	<ol style="list-style-type: none"> <li>1. One-window monitor mode, click this button to display assistant function: PTZ control and image color;</li> <li>2. Detection areas setting(like in motion detection setup), working with Fn and direction keys to realize setup;</li> <li>3. In text mode, click it to delete the character before the caret(if there is no shift on the front panel, it can switch input methods), press this button for 1.5sec to clear all of the characters;</li> <li>4. In playback mode, switch the full screen;</li> <li>5. Realize other special functions.</li> </ol>
10	◀	Previous record/ Iris-	<ol style="list-style-type: none"> <li>1. In playback mode, playback the previous video;</li> <li>2. In PTZ mode, Iris-.</li> </ol>
11	▶	Next record/Iris+	<ol style="list-style-type: none"> <li>1. In playback mode, playback the next video;</li> <li>2. In PTZ mode, Iris+.</li> </ol>
12	▶	Next Frame	Playback the next frame (frame by frame)
13	»	Fast Playback	Various forward speeds and normal speed playback.
14	●	Stop	In normal playback click this button to stop playback.
15	◀/I	Reverse/Pause	<ol style="list-style-type: none"> <li>1. In normal playback click this button to pause playback;</li> <li>2. In pause mode, click this button to reverse playback.</li> </ol>
16	▶/I	Play/Pause	<ol style="list-style-type: none"> <li>1. In normal playback click this button to pause playback;</li> <li>2. In pause mode, click this button to resume playback.</li> </ol>

The procedures of controlling multiple DVR by remote control:

The DVR ID default is 8. It's no need to reset it when control one single DVR by the remote control. If you need to control multiple DVR, do as below:

First activate the remote control: choose controlled DVR, starts successfully, aim the remote control to control the hard disk video recorder, press the "Add" button, input device ID) between (1-999), then press ENTER to

determine can control the corresponding number of hard disk video recorder.

## 6.2 The Mouse

The mouse is used to operate all aspects NVR.

### **Right mouse click is used to:**

- Open up a new menu in the real-time monitoring screen.
- Exit the current screen without saving.

### **Left click is used to:**

- Enter the desired menu or the main screen.
- Select menu options.
- Select/unselect the checkboxes.
- When controlling a PTZ camera.

### **Double click is used to:**

- Play video.
- Make selected camera full screen or to exit full screen mode.

### **Scrolling wheel is used to:**

- Change the value in the digital box.
- Switch the option of the combination box.
- Control the zoom function of the PTZ cameras.

### **Mouse drag can be used to select:**

- Area for facial detection.
- Areas to block (for motion detection).
- Select zooming function of PTZ control.

## 6.3 On-screen keyboard

The onscreen keyboard is operated via the mouse's left click. To enter passwords, usernames, values, etc.

Shift = Caps on/Caps off







Left pointing arrow = Left/delete

␣ = Space between characters











## 6.4 Icon

### 6.4.1 The Screen Icons

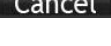
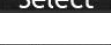
-  : The channel is recording.
-  : The video feed of the channel has been lost.
-  : Motion detection functionality is on.
-  : The channel is in monitoring and locked status.
-  : Adjust the volume of audio output.
-  : Slideshow of all connected cameras, in full screen.

### 6.4.2 Operation Icons

-  : Not selected.
-  : Be selected.
-  : The drop - down button
-  : Leave the interface.
-  : Cancel the settings.
-  : Set parameters.
-  : Save parameters.
-  : Restore the factory settings.
-  : Apply current settings to the system.
-  : Copy current settings to other channels.

**Set**: Enter the configuration interface.

**Process**: Select and configure the processing operation triggered by video detection or alarm.

## 7 Installation

### 7.1 Unpacking Inspection

When you receive the product, check according to the packing list in the box.

### 7.2 HDD Installation

#### Installation Preparation

Prepare a Cross Screwdriver.



*Note: HDD quantity by each model's specifications shall be final, HDD capacity up to 64 TB.*

#### Steps

Remove the metal top cover by removing two screws from the sides of the cover.

Place the hard disks on a flat table and tighten the screws.

Connect the power and the data lines to the HDD.

Reinstall the metal top cover and tighten the screws.

#### Caution

Only use the HDD specified by the manufacturer.

The HDD will be formatted automatically during booting and it may cause data loss.

The total duration of video data saved is decided by the HDD's capability and the DVR's parameters (recording setup, encoding setup). Please refer to the form in chapter 11.5.

### 7.3 Wi-Fi Camera Installation

Follow the steps below to successfully install Wi-Fi cameras:

- 1) Power on the NVR and Wi-Fi camera, all cameras are placed around NVR and connected antennas. The system will run finishing after about 5min, if all channels come video, it means the system works well and then you can go to choose the install place.
- 2) To confirm the NVR's placement. It is recommended that NVR should be placed in the center of the

monitoring area. As far as possible, the installation position of IPC and NVR avoid obstacles (the coverage is affected by the physical properties and surrounding environment of obstacles).

3) To confirm the IPC's placement:

- Install the camera in the wireless signal effective coverage area, and provide 12V power.
- Power on after 1min, the NVR will display the video.
- If no video, the distance is too far to connect, please shorten the distance.

## 8 Basic Operations Guide

### 8.1 Power On/Off

#### 8.1.1 Power On

Install the system correctly (as above) and then connect the power, the system will boot automatically.

The NVR will then automatically detect any connected hardware (cameras, monitors, etc.), this process should last about 30 seconds. When this process has been completed the NVR will enter the multi-screen real-time surveillance mode.

If your hard drive is not properly connected, the following message will appear on your screen.

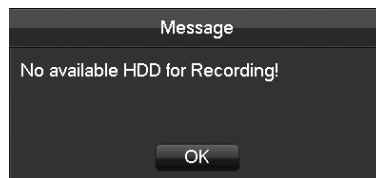

*Note: Please do not use any type of power supply which is different from the power supply included in this kit.*

#### 8.1.2 Power Off (Shutdown)

Right mouse click -[Main Menu]-[Shutdown]

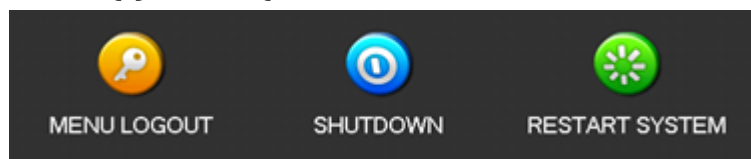





*Note: Only change or attempt to reconnect the hard disk drive after shutting down the NVR.*

### 8.1.3 Restart

Right mouse click -[Main Menu]-[Shutdown]-[Restart system]

### 8.1.4 Power recovery

Reboot after an outage or forceful shutdown, DVR will save the record before outage and return to the normal operation mode.

## 8.2 Start-up Wizard

Quick configuration includes System Generic Config, network configuration, etc.

### **System Generic Config**

System Generic Config includes System Time, DST, Time Zone, NTP enable, Language, Video Standar.

System Time	2018 - 05 - 31   09 : 06 : 32
DST	<input type="checkbox"/> <b>Setting</b>
Time Zone	((GMT+08:00)Beijing, Singapore, T ▼)
NTP Time	<input checked="" type="checkbox"/>
Language	ENGLISH ▼
Video Standar	PAL ▼

Save Previous Next Step

**[System Time]** Set the current time.

**[Daylight Saving Time (DST)]** Enable the function, and enter the local DST starting and ending time.

**[Time Zone]** Current local time in cities worldwide.

**[NTP]** Turn the NTP On/Off. The network time protocol allows the NVR to sync with NTP server time automatically.

**[Language]** Select language.

**[Video Standard]** PAL/NTSC.

## Network config

The screenshot shows a 'Network Config' window with the following settings:

DHCP	<input checked="" type="checkbox"/>
IP Address	10 . 12 . 4 . 133
Subnet Mask	255 . 255 . 255 . 0
Gateway	10 . 12 . 4 . 1
AUTO DNS	<input checked="" type="checkbox"/>
Preferred DNS	8 . 8 . 8 . 8
Alternate DNS	8 . 8 . 8 . 8

Buttons at the bottom: Save, Previous, Test

**[DHCP]** Enable the NVR to obtain an IP address automatically. If it is enabled, the NVR will reboot and search for a DHCP server, and then assign a dynamic IP address. The dynamic IP address will be displayed in the menu. Enter a static IP address if there is no DHCP service available. If you are using the advanced feature PPPOE, then the IP/mask/gateway and DHCP are unable to be changed.

**[IP address]** Use (▲▼) or input numbers to modify IP, then set **[subnet mask]** and **[gateway]** for this IP.

**[AUTO DNS]** Enable the NVR to obtain a DNS address automatically.

**[DNS 1]** DNS server IP address.

**[DNS 2]** DNS alternate IP address.

**[Test]** To test whether the NVR connect internet successfully.

Message	Message	Message
network testing,please wait a moment...	Network connection success	Network connection failed. Please reconfigure or skip configuration
OK	OK	configurat Ignore

## Network Application

1) Show the download information, includes P2P WEB, android app and iPhone app.

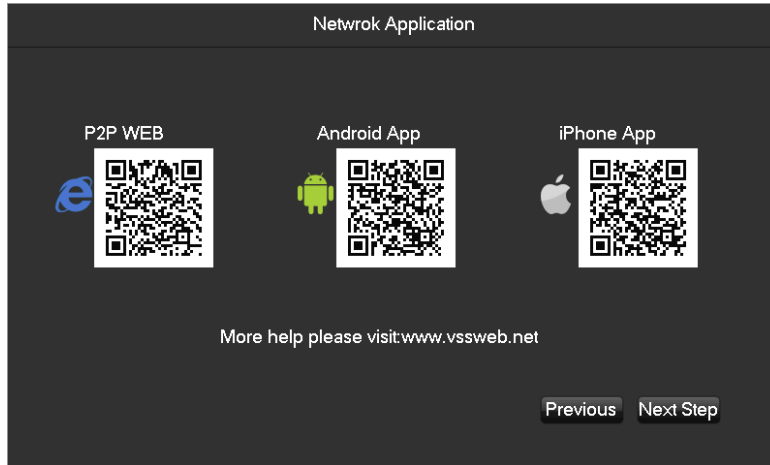

2) Show the P2P information, scan the QR code by app, then can remote control the NVR.

### Hard disk management

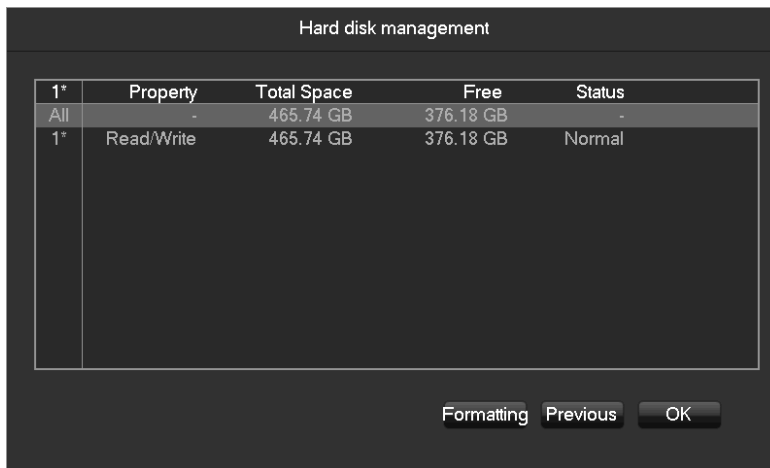

[Format] It is possible to format an individual HDD.



*Hard disk format operation result in the loss of video data.*

## 8.3 The right-click Menu

Enter the real-time channel browsing interface. Click the right button on the mouse to bring up the pop-up menu as shown in the figure below.

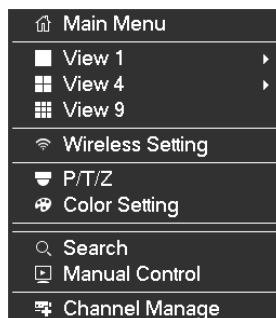

### 8.3.1 The screen Switching

Click the right mouse button on the real time monitoring screen to bring up the options list, and select either 'View 1', 'View 4' or 'View 9' from the list.

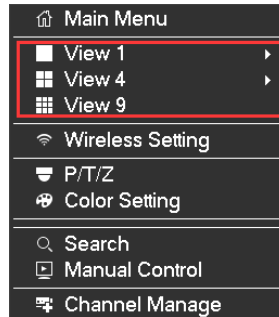

Users can choose to have either single or four channels.

### 8.3.2 Wireless Setting

Click the right mouse button on the real time monitoring screen to bring up the options list, and select 'Wireless Setting' from the list.

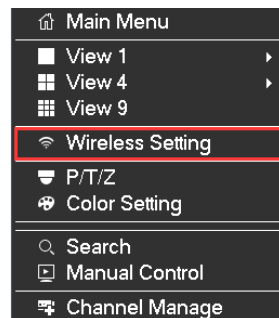

The wireless setting interface is show in the following image:

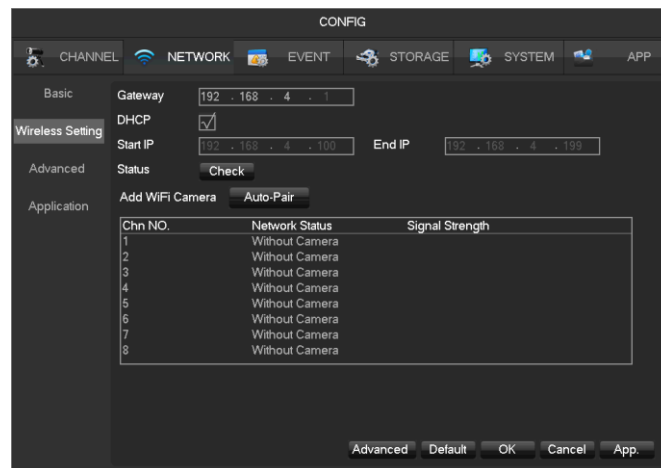

See **Chapter 4 Configuring the IP camera to work on the NVR** for further instructions.

### 8.3.3 P/T/Z

Click the right mouse button on the real time monitoring screen to bring up the options list, and select 'P/T/Z' from the list.

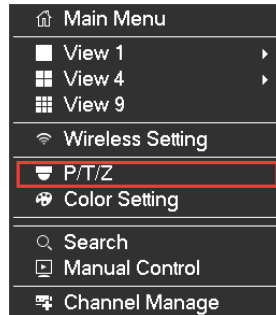

When the NVR is connected with a network PTZ camera, right click the corresponding network channel and select [PTZ] to enter into the PTZ interface.

The PTZ control interface is shown in the following image:



Click  to enter the PTZ configuration page:

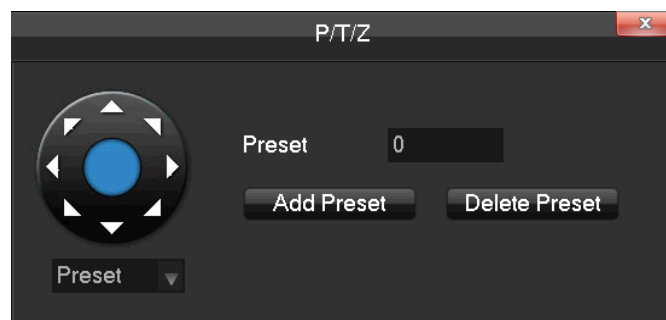

#### 8.3.3.1 PTZ Configuration

The direction of the PTZ camera, steps, zoom, focusing, iris, preset points, cruising between points, patrols, sweeping the boundary, calling an auxiliary switch, light switch, horizontal rotation are controlled using the directional arrow keys.

The [Step] is mainly used to control directions. The figure can be set from 1 to 8. Directly click  or  to

adjust the zoom, sharpness and brightness. PTZ supports eight directions.

### 8.3.3.2 Quick Location

Quick location: <SIT> is in the middle of the direction arrows, shown in the red circle below:



Make sure that the PTZ's protocols support this function. The PTZ will turn to the clicked point and move it to the centre of screen. It also supports zooming into and out of the video image. Drag the mouse in the quick location page to zoom into an area of the footage. The dragged box can zoom in to the image in between 4 to 16 times. Hold the mouse and drag it up to complete zoom of the box. Drag it down to narrow the box.

### 8.3.4 Color Setting

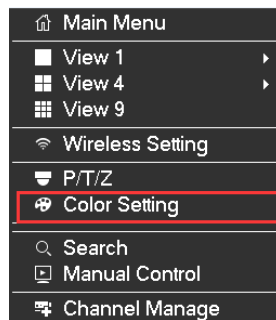

If you need to set a certain color level configuration on the channel browsing display interface for a certain time of day (e.g. one configuration for the daytime and another configuration for the night time), you can set this up via the 'Color Setting' menu found on the right-click menu. You can set two time periods for two separate color configurations that suit the lighting environment around where you view the footage from the cameras on the display monitor.

Image color hue, brightness, contrast, saturation, sharpness can all be adjusted to desired levels, also can change the color mode and image mode. See screen shot of the Color Setting menu on the next page.

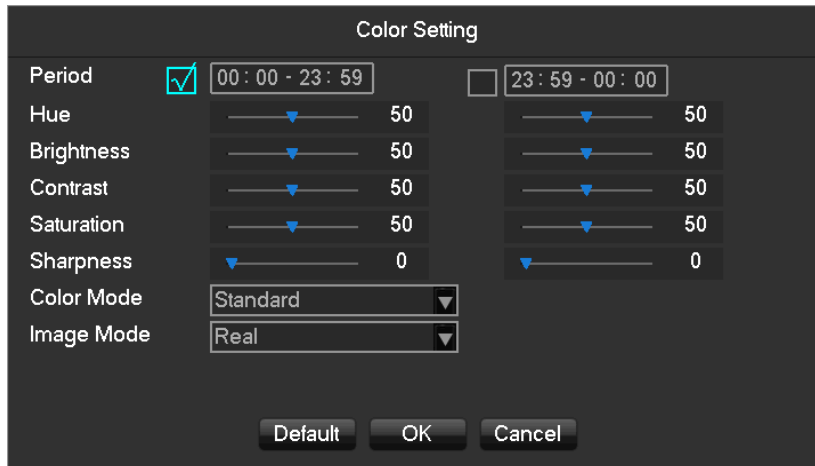

**[Period]** Two periods can be set according to ambient light during the day and night, device will automatically switch configuration time. Need to select the Enable box.

**[Hue]** Adjust the image color cast.

**[Brightness]** Visual image brightness (according to the environment), reduces or increases the brightness of the image to try to make it clearer.

**[Contrast]** Adjusts the black and white color the image (the greater the ratio, the brighter the image).

**[Saturation]** Image color purity. The greater the value the more colorful the images will become.

**[Color Mode]** Support Standard mode and Gorgeous mode.

**[Image Mode]** Support Real mode and Transparent mode.



*Different mode different function.*

### 8.3.5 Search

To playback recorded footage and search for particular video incident on a particular date and time right click button on the real time monitoring screen to bring up the options list Select 'Search' from the options and the video enquiry console will appear.

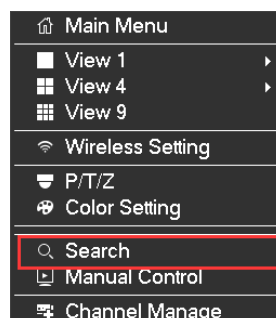

See **Chapter 9.2.1 Search (The Video Inquiry)** for further instructions.

### 8.3.6 Manual Control

To set which camera channels to have scheduled recording times or to record continuously through the day, click

the right mouse button on the real time monitoring screen and select 'Record' from the options list.

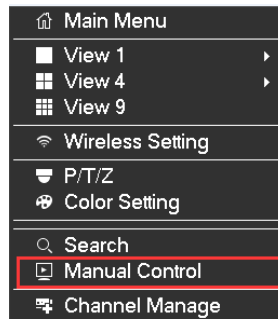

You will see this window appear:

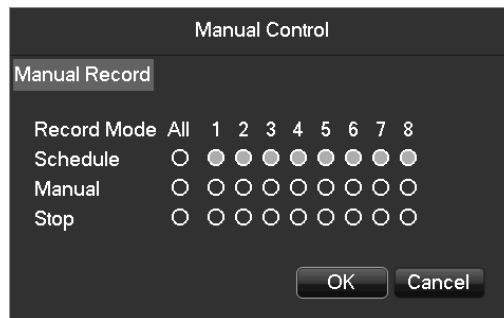

**[Manual]** The tick boxes in this row have the highest priority and when you have ticked the corresponding channels the NVR will record continuously.

**[Schedule]** Record footage from the cameras at customized times during the week.

**[Stop]** Stop recording on that channel.

### 8.3.7 Channel Manage

To manage the IP cameras on your network, click the right mouse button on the real time monitoring screen and select 'Channel Management' from the options list.

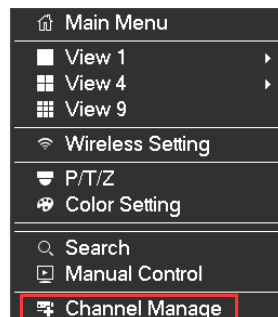

The window that appears is shown below:



QUICK ADD IP CAMERA

ID	Add/Del	Status	IP/DoMain	Port	Protocol	Edit	Advanced
01	+	--	10.12.4.68	8000	TYPE1	⚡	⚡
02	+	--	10.12.4.70	8000	TYPE1	⚡	⚡
03	+	--	10.12.4.71	8000	TYPE1	⚡	⚡
04	+	--	10.12.4.84	8000	TYPE1	⚡	⚡
05	+	--	10.12.4.115	8000	TYPE1	⚡	⚡
06	+	--	10.12.4.116	8000	TYPE1	⚡	⚡
07	+	--	10.12.4.168	8000	TYPE1	⚡	⚡
08	+	--	10.12.4.193	8000	TYPE1	⚡	⚡
09	+	--	10.12.4.194	8000	TYPE1	⚡	⚡
10	+	--	10.12.4.217	8000	TYPE1	⚡	⚡
11	+	--	192.168.1.11	8000	TYPE1	⚡	⚡
12	+	--	192.168.1.21	8000	TYPE1	⚡	⚡
13	+	--	192.168.1.22	8000	TYPE1	⚡	⚡
14	+	--	192.168.1.26	8000	TYPE1	⚡	⚡
15	+	--	192.168.1.86	8000	TYPE1	⚡	⚡
16	+	--	192.168.1.87	8000	TYPE1	⚡	⚡
17	+	--	192.168.1.88	8000	TYPE1	⚡	⚡
18	+	--	192.168.1.89	8000	TYPE1	⚡	⚡
19	+	--	192.168.1.90	8000	TYPE1	⚡	⚡

Filter: TYPE1   Search   Add   Delete   Ping   Status   Open UPnP

**[Add]** Add the IP Camera(s) into the Net channels, which you have selected.

**[Delete]** Delete the IP cameras you have selected from NET channel list

**[Protocol]** The protocol used by the IP camera(s).

**[Search]** Search for the online IP Camera(s) in the network.

**[Ping]** Input the remote IP address and check the connection status.

To setup an IP camera with the NVR please go to **Chapter 9.4.1.1 Channel Manage** for future instructions.

### 8.3.8 The Main Menu

To go to the Main Menu of the NVR, click the right mouse button on the real time monitoring screen and select 'Main Menu' from the options list.

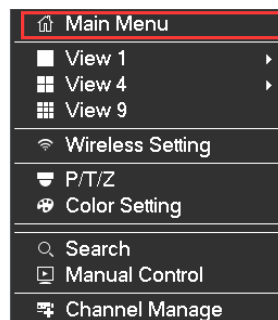

Input a user name and a password.

System Login

User Name:

Password:

OK   Cancel

Default users:

User Type	Name	Default Password
Administrator	admin	123456
User	user	123456
Hidden	Default	default



*security measures of the password: If you input the wrong password three times, the device will produce an alarm sound. After incorrectly inputting the password in five times, the account will be locked. Please change the default password and the user name. Refer to **Chapter 9.4.5.4 'Accounts'** for more details.*

### 8.3.9 Live Preview







Below is the multi-screen real-time surveillance mode:



#### 8.3.9.1 Channel Toolbar

Move mouse to the top of channel screen, it will show channel toolbar as follow:



-  Real-time playback in five minutes.
-  Backup the last five-minute video to U disk, backup time can be set.
-  Snapshot and backup to U-disk.
-  Channel toolbar is temporarily closed within 30 seconds.
-  Set the volume of sound.
-  Set the bothway talk.

### 8.3.9.2 Task Toolbar

Move mouse to the bottom of screen, it will show task toolbar as follow:



#### 1) The Screen Switching

Click the task toolbar, and select either 'View 1', 'View 4' or 'View 9' from the list.



Users can choose to have either single, four or nine channels.

#### 2) Search



To playback recorded footage and search for particular video incident on a particular date and time right click button on the real time monitoring screen to bring up the options list Select 'Search' from the options and the

video enquiry console will appear.

### 3) **Manual Record**

To set which camera channels to have scheduled recording times or to record continuously through the day, click the right mouse button on the real time monitoring screen and select 'Record' from the options list.



### 4) **Wireless Setting**

To set wireless parameters, and add new Wi-Fi cameras.



### 5) **Channel Management**

To manage the IP cameras on your network.



### 6) **Network Application**

To show the application download information and P2P ID information.



The window that appears is shown below:

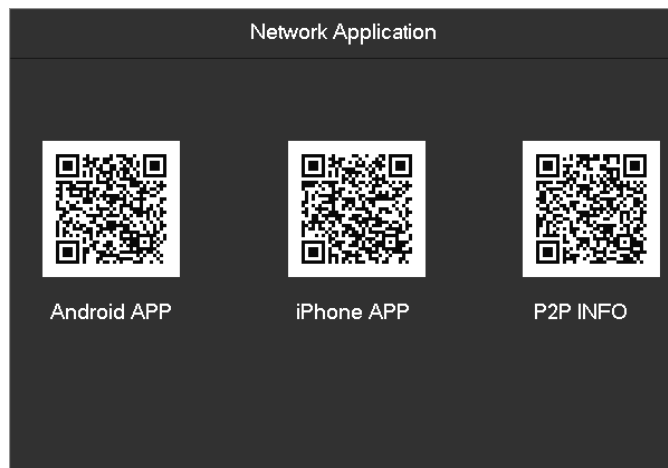

### 7) **Alarm Status**

Check the recent alarm status, click to show the following alarm message



The window that appears is shown below:

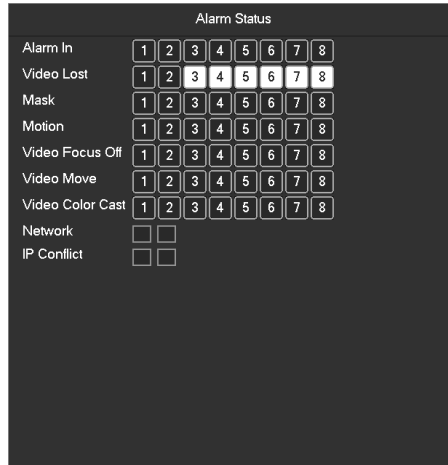

### 8) PTZ control

Brings up the PTZ control Menu.



### 9) Event List

When the system is face/perimeter analysis status, click to switch show/hide the intelligent window in the right side of real-time monitoring screen.



The window that appears is shown below:

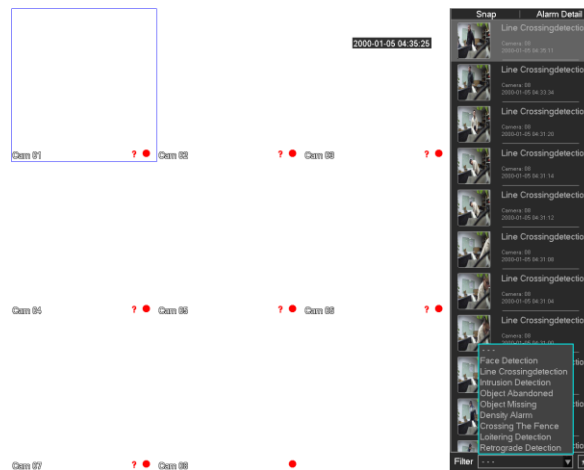

**[Filter]** Events filter: Face detection, Line Crossing detection, Intrusion detection, Object abandoned, Object missing, Density alarm, Crossing the fence, Loitering detection, Retrograde detection.

 Tag the event.

### 10) Taskbar Config

Chose the taskbar resident or automatically, and display at Bottom or TOP.



The window that appears is shown below:

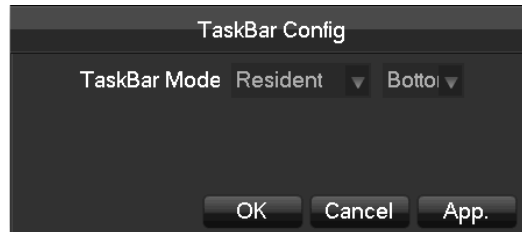

## 11) Shutdown

Menu logout, device shutdown, system reboot.



# 9 Local Configuration

## 9.1 The Introduction of the Main Menu

The main menu is shown in the image below:

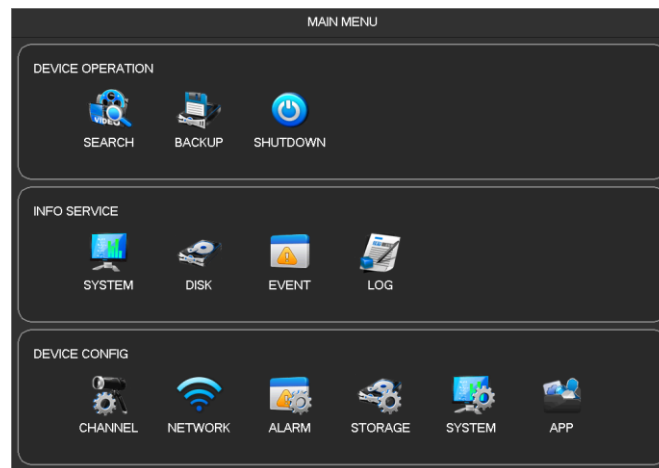

### 1) DEVICE OPERATION

**[Search]** Search recorded footage by types, channels, time and playback records.

**[Backup]** Backup records.

**[Shut Down]** Takes you to the Shutdown menu.

### 2) INFO SERVICE

**[System]** Displays the system status, version information.

**[Disk]** Displays the HDD information.

**[Event]** Display the alarm information.

**[Log]** System log information.

### 3) **Device Config**

**[Channel]** Add / Remove the camera, the camera parameters, the basic parameters of the channel configuration, channel mode switch, channel events and joint management parameters.

**[Network]** Basic network configuration parameters settings, manage network interfaces, configure advanced network services.

**[Alarm]** External alarm events and abnormal events of the configuration parameters of the device and joint management.

**[Storage]** Hard disk storage configuration management, video parameter settings, set the record schedule.

**[System]** Configuration System parameters time, date, language configuration, management and video output parameters polling settings.

**[APP]**E-mail, P2P, cloud storage, mobile phones and other common functions push settings.

## 9.2 Device Operation

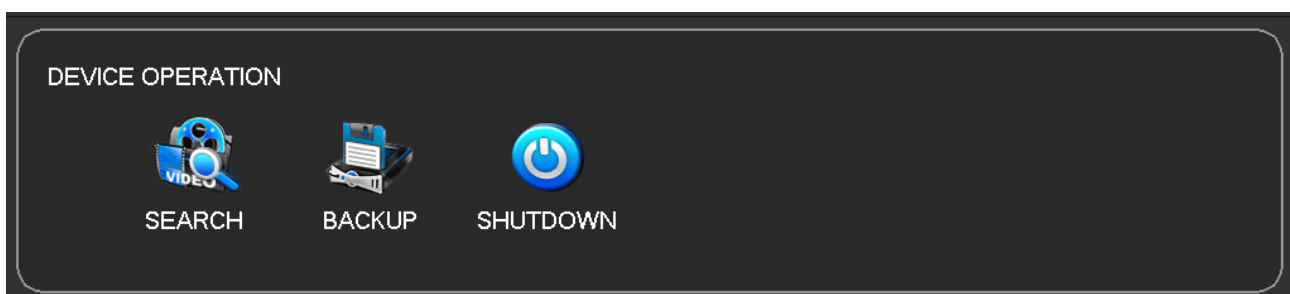

### 9.2.1 Search (The Video Inquiry)

You can access the Video Inquiry either right clicking the mouse button In the real-time monitoring screen and selecting [search] or you can select the 'Search' option in the main menu.

## 9.2.1.1 Normal Search

Video Inquiry console: this is the view after you have selected which time & date you would like to view footage from. You can see on the right hand side the list of video records to look through.

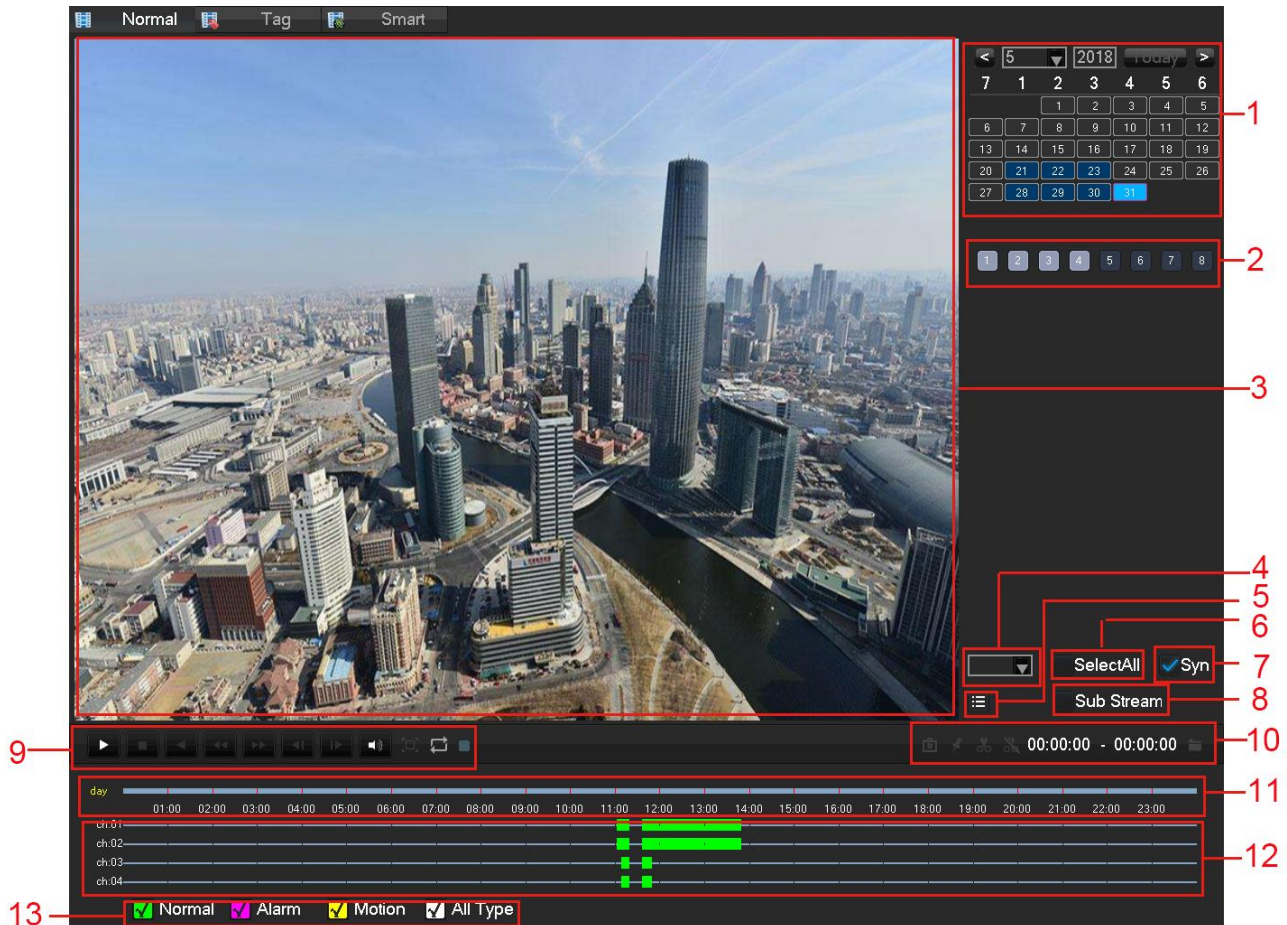

### Record Search interface description:

Index	Type	Description
1	Choose the date	Select the time and date to search records.
2	Select channels	Choose the channels for querying.
3	Playback window	Playing video.
4	Time bar channel	When you select the number of channels is more than 4, a channel number value for the timeline display
5	List	Show the status information of channels' video recording within one day by green, red, yellow.
6	All Channel Select	All select, all cancel
7	Synchronization	Achieve the playback of each channel's record is of synchronization in time and of consistency in operations.
8	Sub Stream	Playback with sub stream recording file.
9	Playback control	Full screen, Loop, Stop/Play, Pause, Fast, Slow, Back, Previous Frame, Next Frame.
10	Video Edit Tool	To realize snap, tag, video cut, etc. functions.



11	Event list	Show all events and time
12	Timeline display	Green, red and yellow colors show the video recording in the one day
13	Search Type	128 video records are shown in the list. Type: R—normal record, A—alarm record, M—motion detection record.

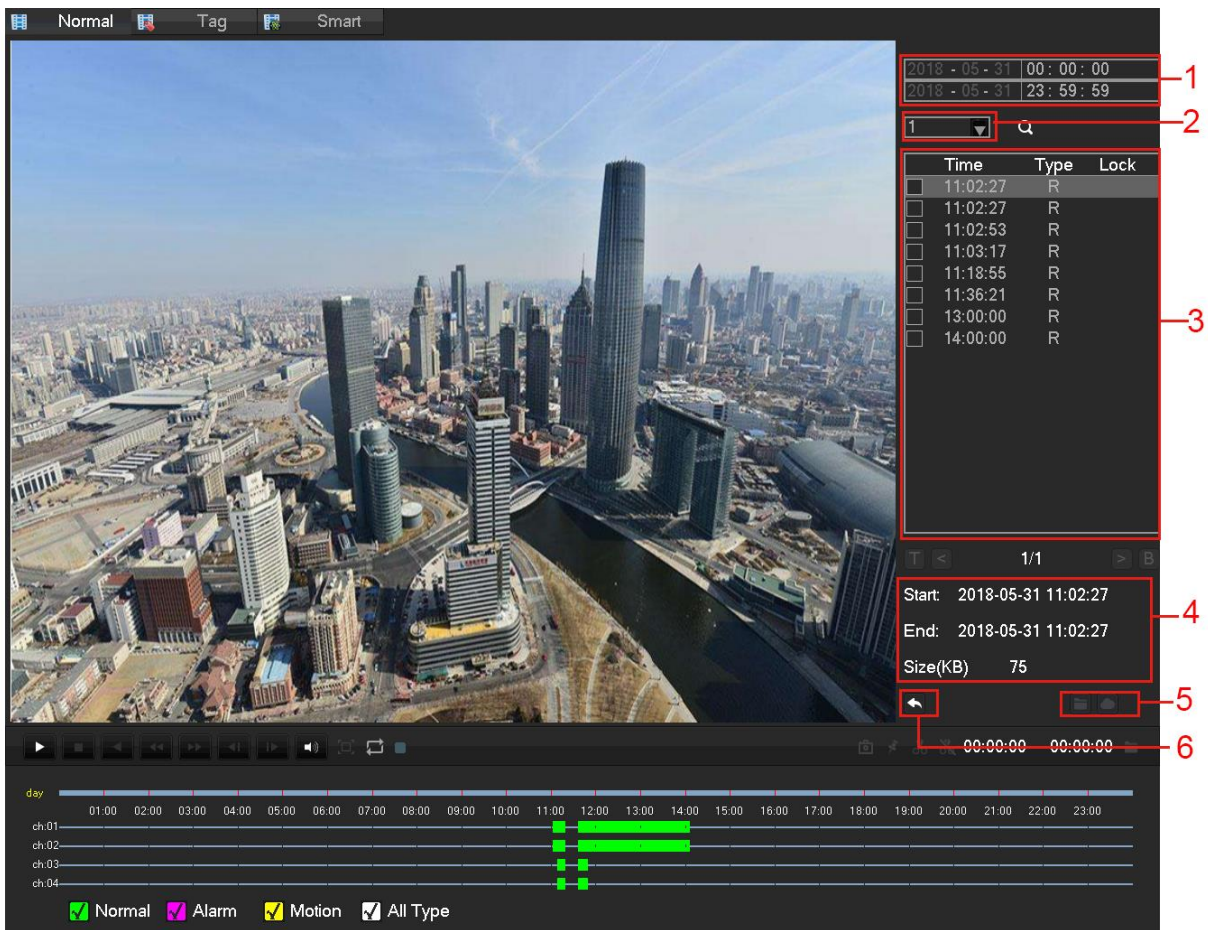













**List:**

Key	Type	Description
1	Time	Choose video query time
2	Channel	Select the desired query video channel
3	File	Query channel video display a list of files
4	File information	Display start time for a single video file, the end time, and video file size.
5	Backup	In the file list box, select the user needs to back up files in the list box playing "📁" to  check, and then click the button (backup) or (uploaded to the cloud disk), the backup operation menu appears, click the Start button, users can also do not want to cancel the backup files in the backup operation menu before you want to cancel the file list box cancel "✓".
6	Back	Exit File List

**Playback Control:**





Key	Description	Remark
-----	-------------	--------





Video playback: Fast-forward Key 	Under playback mode, pressing this key, you can get a variety of fast cycle switching speeds; fast-forward button can be used as slow-release button reverse switch key.	Actual play rate based on version
Video playback : Slow key 	Under playback mode, pressing this key, switch cyclically support a variety of slow-release rate, slow release button can be used as fast-forward button reverse switch key.	
Play/pause  / II	Play/pause switch when slow-play	
Backward: Backward key 	Single left click backward key	To play backwards and single click again to stop back run under common playback Rewind or single-frame playback, press the play button  /  to enter the normal playback .
Manual single frame playback 	single frame playback by clicking    and    when common playback pause	
Audio 	Adjust the audio	
Full screen 	Full screen	
	When the loop is turned on, the day after the end of the video playback, video playback file start over again	
	Display the current status: normal playback, reverse playback, fast playback level, etc.	Just display the status, can't set.



1. The player playback control bar shows file playback speed, channel, time, playback progress and other information.
2. Playback speed and rewind function are related to DVR version, and please prompt on the player panel shall prevail.

### Video edit button:

Key	Description	Remark
Snapshot: 	When Playback, left-click on the icon, the snapshot of focus on window will back up to the U disk	Insert U disk, enter Search , supports a maximum resolution of 1080P
Tag: 	Left-click the icon, you can add tags to focus channel	set the tag name letters, numbers, special characters, the total length of no more than 31 characters. The tags can be used to add labels to retrieve.
Cut: 	Left click  , start to cut record, Starting time: click  focus	If the focus of the shearing process channel change, places the focus of the channel when the end of the

	<p>window, icon turn to ; left click again  complete cutting,</p> <p>End time: click  focus window. After finish cutting, click  to back up record, or right click to exit cut feature.</p>	<p>shear cut as a video channel. Shearing process can playback control. When the cut end time is earlier than the start time cut, cut start time automatically reversed.</p>
--	--	--

### 9.2.1.2 Tag Search

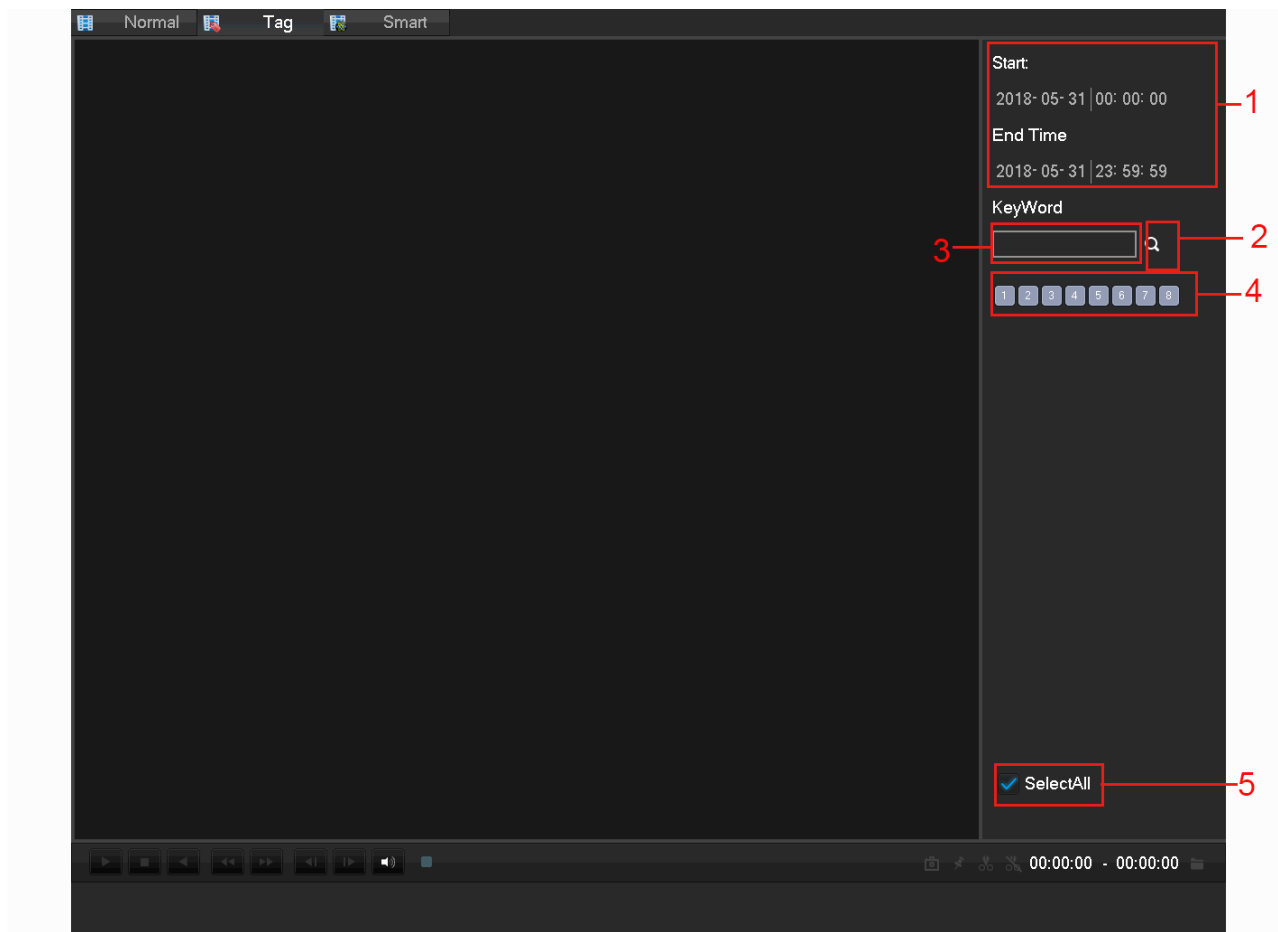

Index	Type	Description
1	Play Timeline	Display the progress bar of the current event
2	Search	Search recoding
3	Event Type	Select the type of event
4	Channel selection	Select the channel
5	Select al channel	Select al channel

3	Channel	Tag Name	Time
1	02	tag2	11-03-2016 12:23:05
2	03	tag1	11-03-2016 12:23:13
3	01	tag	11-03-2016 12:27:26

Total 3 Page 1/1  
 Before/After 30 Sec Turn < > Delete

### 9.2.1.3 Smart Search

Intelligent playback that video playback time, according to the input retrieval conditions, video analysis, quickly locating the qualified video, and playback.

Currently our DVR, TVR device supports retrieval based on intelligent motion detection playback area.

Enter the smart playback interface, the interface as shown in FIG.

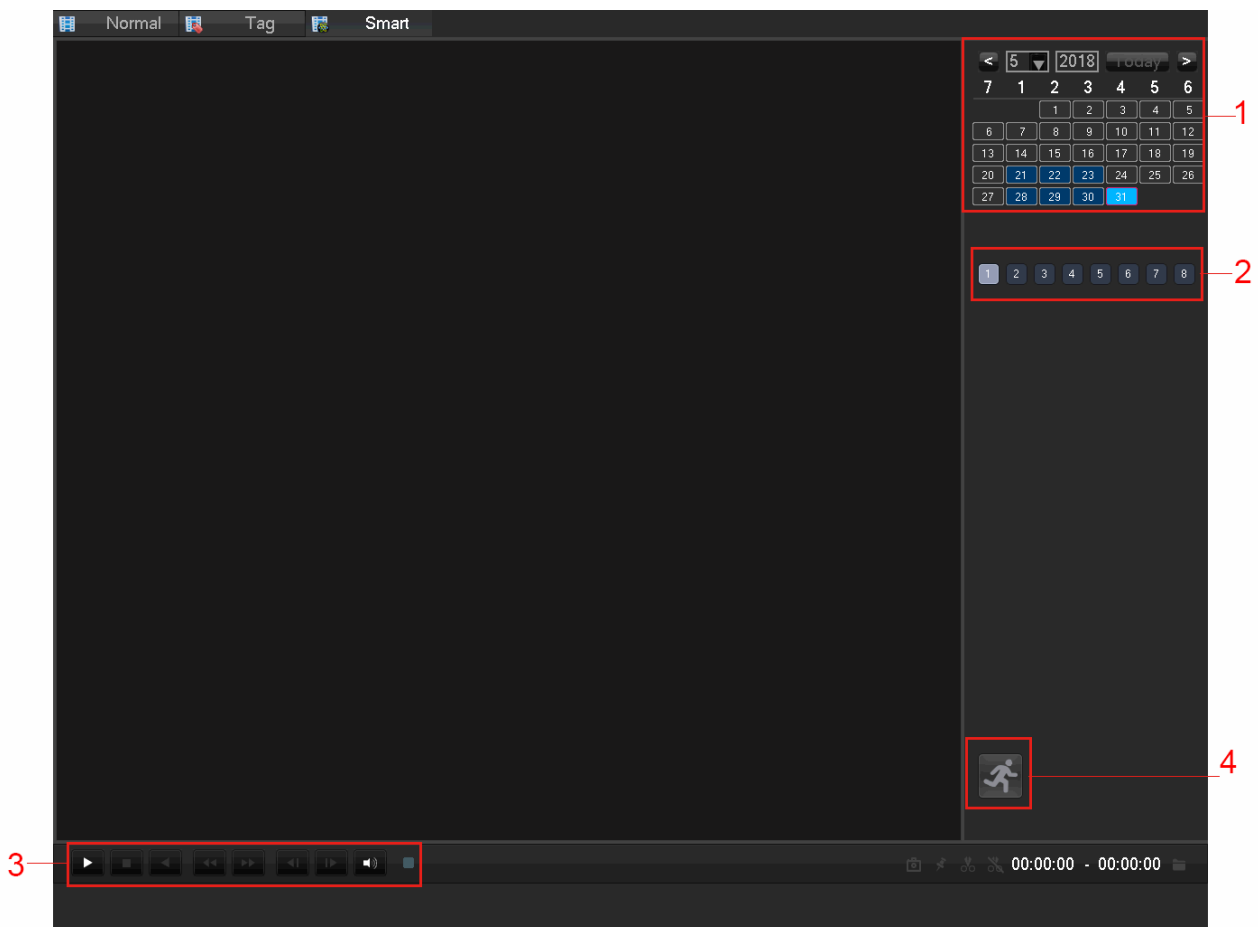

Intelligent playback using the following process

1. Position 1, select the desired search date.
2. Position 2, select the desired search channel (radio).
3. Left-click on the third position to start playback.
4. Left-click on the icon position 4, select dynamic inspection area.
5. Full-screen setting area is completed, the right mouse button to exit the configuration. Complete search, video recording shall be the date the presence of all the moving subject information of the channel region is configured to display on the timeline.

## 9.2.2 Backup

### 1) Interface Description

Connect an External USB device with the USB port to backup file in the **[Record Backup]** menu.

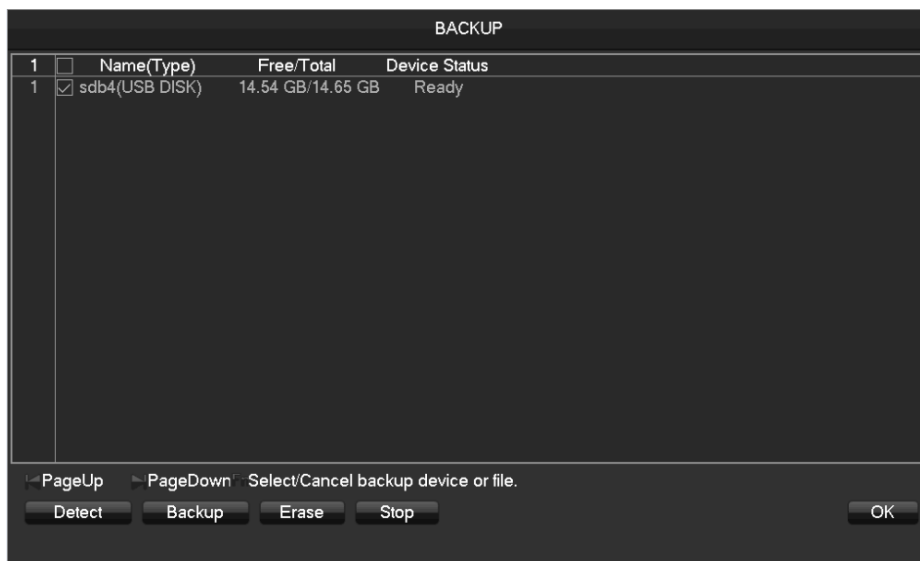

**[Detect]** Identify external USB device and display the device information.

**[Backup]** Tick the external device and click **[Backup]** to enter the backup menu .

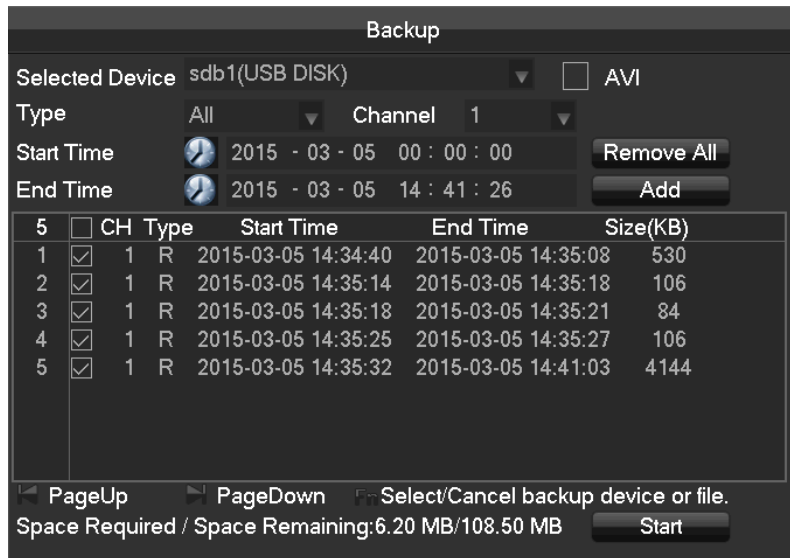

[Cancel] Delete all data in USB backup device

## 2) Backup Operations

Connect an External USB device with the USB port, click **[Detect]** to Identify external USB device, click **[Backup]** to enter the backup menu, select the record start -stop time and click to add files in list, click **[Start]** to backup and display time remaining.



*USB backup carry player automatically. This operation probably will cause permanent data loss.*

## 9.2.3 Shutdown

Takes you to the Shutdown menu.

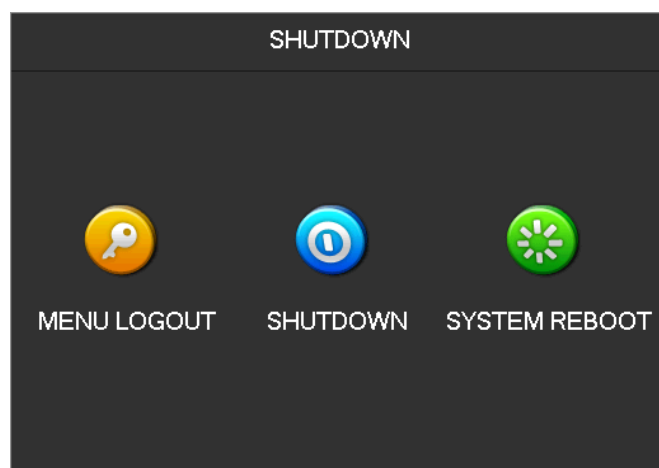

## 9.3 Info Service

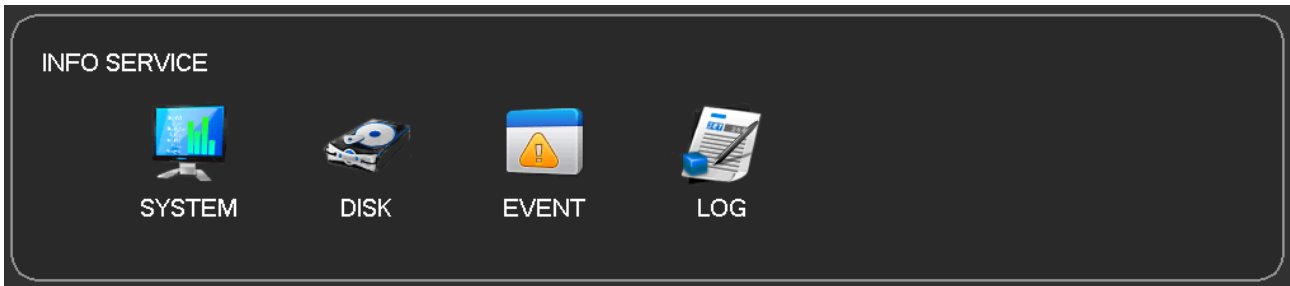

### 9.3.1 System

To display device serial number, system hardware features, software version and release date information. As shown below:

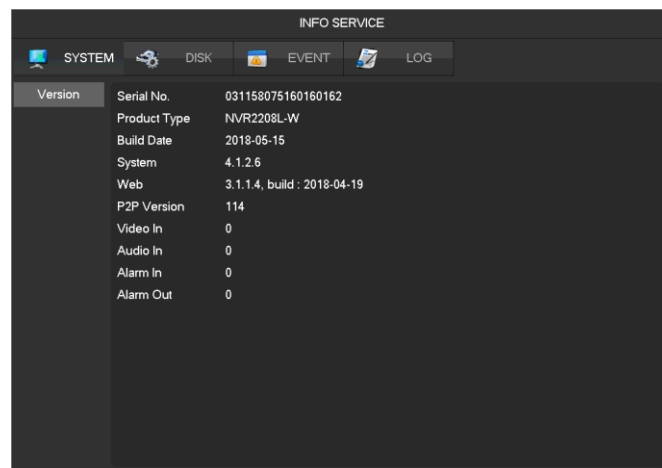

The screenshot shows the "INFO SERVICE" interface with the "SYSTEM" tab selected. It displays a list of system information:

Version	Serial No.	031158075160160162
Product Type	NVR2208L-W	
Build Date	2018-05-15	
System	4.1.2.6	
Web	3.1.1.4, build : 2018-04-19	
P2P Version	114	
Video In	0	
Audio In	0	
Alarm In	0	
Alarm Out	0	

### 9.3.2 Disk

#### 1) HDD Manage

Display the HDD healthy and capacity.

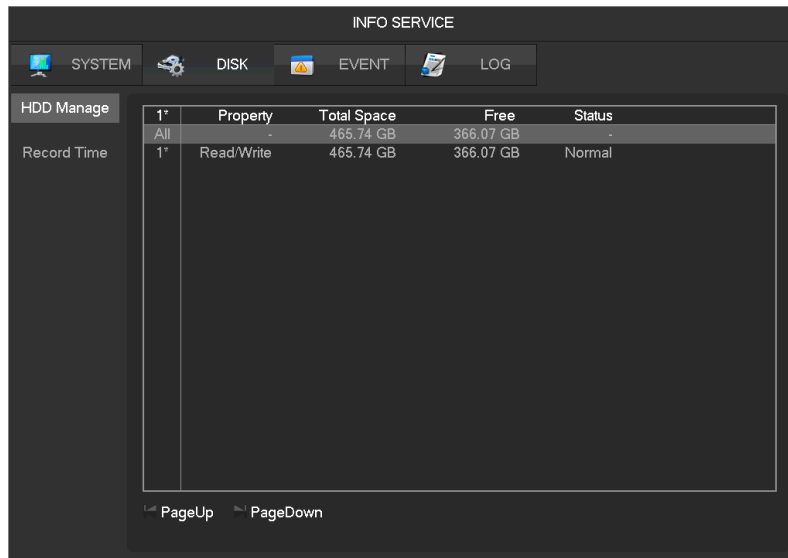

## 2) Record Time

Displays the recording time in the HDD.

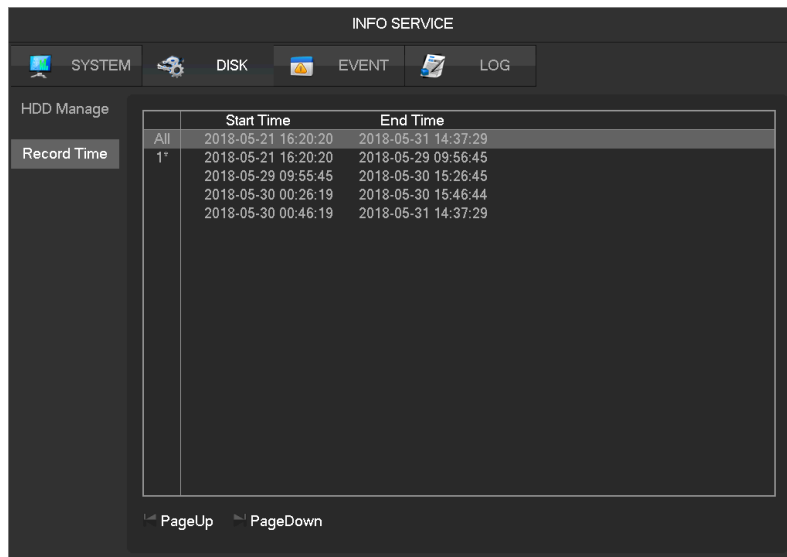

## 9.3.3 Event

Display the alarm status, includes alarm in, video lost, mask, motion, VQC (video focus off, video move, video color cast), network, ip conflict.



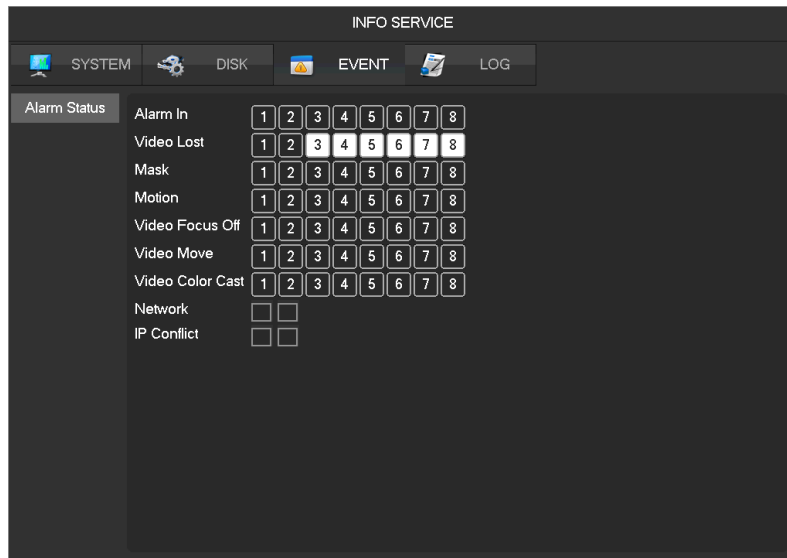

The selected channel means alarm alert.

### 9.3.4 Log

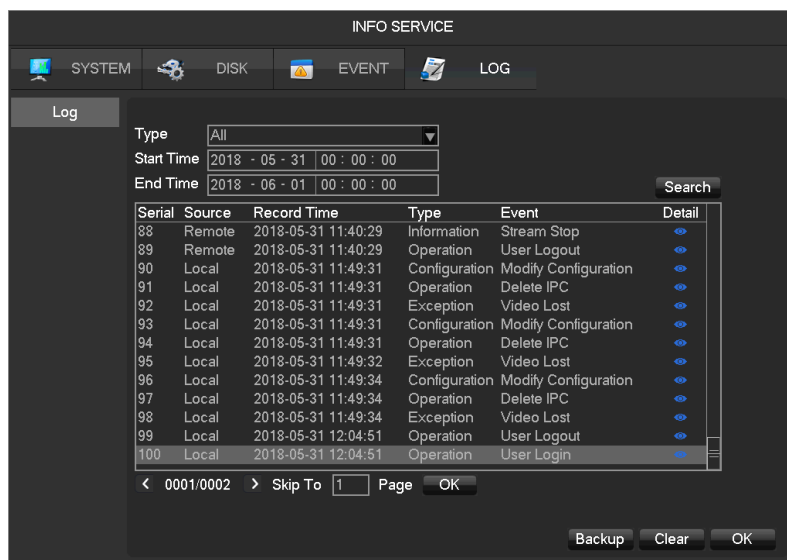

Log information can be divided into system operation, configuration operation, data management, alarm event, recording operation, user management, log clear, file operations.

Select the type and time of the query, press the Find button, the system displays the log as a list, and click the Backup button will log export backup to your computer.

Click the Clear button, the system will remove all types of log files.



## 9.4 Device Config

### 9.4.1 Channel

#### 9.4.1.1 Channel Manage

You can use channel management to add or delete IP devices and set the front-end configuration.





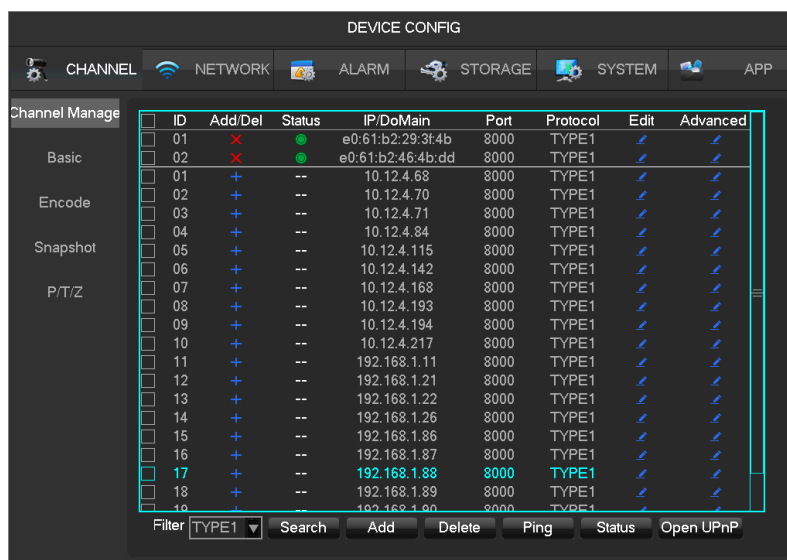

There are three ways to log in [Channel Manage]

- 1) Living preview, click the button  in the task toolbar.
- 2) Right click the mouse on the living preview, click the button  Channel Manage in the right-click menu.
- 3) [Main Menu]-[Channel]-[Channel Manage].

Channel management menu as the following page:



[Check Box] Click the check channel, double click can deselect channel, Click the title bar to achieve selection, double click can deselect all.

- [Serial Number] Display the network channel number to add equipment serial number.
- [Add、Delete] Click  to delete the current IP camera. Click  to add new cameras.
- [Status] Show the current channel connection status:  Connection is normal,  ID or Password is wrong,  the equipment is offline,  User is lock.
- [IP Address/Domain Name] Display the equipment's IP address/domain name.
- [Edit] Configure the channel information, see **Chapter 9.4.1.3 Modify channel configuration** for further instructions.

- [Advanced] Configure the camera's parameters, see **Chapter 9.4.1.2 Advanced** for further instructions.

## 9.4.1.2 Advanced

Click the advanced setting button, will show the Advanced Setting menu.

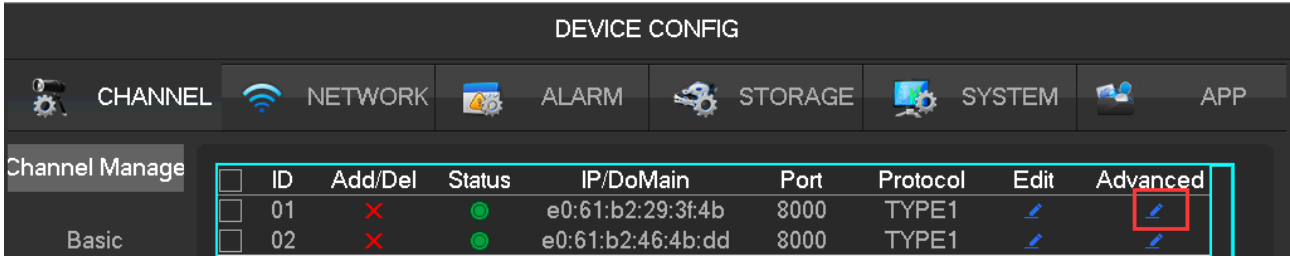

- The front-end device has been added into IP channel:

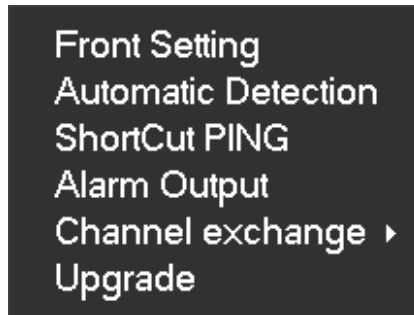

[Front Set] See **9.4.1.5 Configure Front Device** for further instructions.

[Automatic Detection] Check connection status of the current channel.

[ShortCut PING] Check the current channel network whether is connected.

[Alarm Output] Set the front-end device alarm output mode.

[Channel exchange] Exchange position of channels.

[Upgrade] Upgrade the Wi-Fi camera.

- The front-end device has not been added into IP channel:



[ShortCut PING] Check the current equipment whether is connected.

[Add To] Add device into the special channel.

### 9.4.1.3 Add IP Cameras

There are three ways to add IPCs.

#### 1) **Automatically Add**

No configuration, the device is automatically added.

Click **[Open UPNP]** in **[Channel Management]** menu page.



*Note: The device should support UPNP and should be in the same LAN.*

#### 2) **Searching Add**

Search all the IPCs in the network environment and then choose one or mass to add. To do the following steps in **[Channel Management]** menu page:

- Click **[Filter]** to select the protocol;
- Click **[Search]** to search devices;
- Click + to add device or Right click **[Add to]** to choose the channel you want or tick the devices you want to add, then click **[Group Add]**.



*Need to update the password by manually after connecting the camera.*

#### 3) **Manual Add**

The screenshot shows a 'Channel Set' dialog box with the following fields and values:

Field	Value
Channels	3 - NET
Protocol Type	TYPE 1
IP/DoMain	
TcpPort	8000
UserName	
Password	
Remote Detect	Detect
Remote Channel	1

Buttons at the bottom: Copy, OK, Cancel, App.

**[Channels]** Choose one channel.

**[Protocol]** Choose protocol supported by the device.

**[IP/ Domain Name]** Input front device IP address or domain name.

**[Port]** Input front device TCP port.

[Username] Input front device username.

[Password] Input front device password.

[Remote Detect]After completing the above settings, click detect button to check connection status.

[Remote Channel]When the front device includes multiple channels, choose one channel for it.

Click “App” button to finish.

### 9.4.1.4 Modify channel configuration

- 1) Click “Edit” button in the Channel list.
- 2) Modify the information table, the table details as follow:

Channel Setting	
Channels	1 - NET
Protocol Type	TYPE1
IP/DoMain	e0:61:b2:29:3f:4b
TcpPort	8000
UserName	admin
Password	••••••
Remote Detect	Detect
Remote Channel	1

Copy OK Cancel App.

### 9.4.1.5 Configure Front Device

Modify the IPC’s Basic configuration, encoding configuration, snapshot, network and motion detection in NVR.

Click “Front Setting” button of device in [Channel Management] –[Advance] menu.

- 1) **Basic**

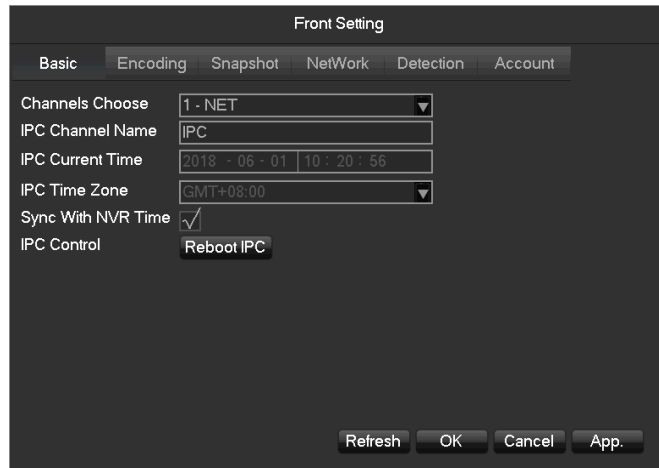

**[Channel Choose]** Choose a channel.

**[IP Channel Name]** Modify current channel name.

**[IPC Current Time]** Set IPC time.

**[Time Zone]** Set time zone.

**[Time Sync]** Enable IPC time sync with NVR.

**[IPC Control]** Click the prompt whether restart the IPC, **[OK]**Restart the IPC, **[Cancel]**Return.

## 2) **Encoding**

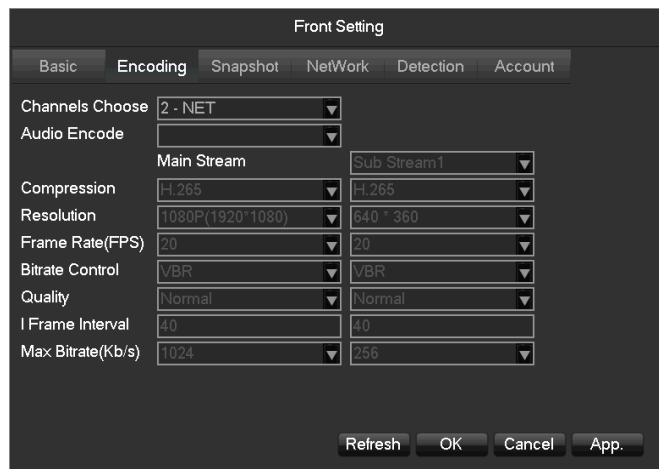

**[Channels Choose]** Choose one channel.

**[Audio coding]** Select the current audio encoding

**[Code Level]** H.264/H.265

**[Resolution]** Choose main resolution and sub resolution.

**[Frame Rate]** 1~20FPS

**[Bit Rate Control]** Choose CBR or VBR. When choose CBR, bit rate can be set. When choose VBR, image quality can be set.

**[Picture Quality]** Choose the picture quality by the Variable stream, there are 6 range to choose.

**[I frame interval]** Set interval of adjacent frames. Max is 150.

**[Bit Rate]** Choose 1280,1536,1792,2048,3072,4096,5120,6144,7168,8192 or set by yourself.



*The range of resolution and frame rate subject to the actual device.*

### 3) **Snapshot**

**[Choose Channel]** Choose the channel to be modified.

**[Snapshot Mode]** Support two modes: trigger snapshot and timing snapshot, the timing snapshot must tick the checkbox.

**[Picture Resolution]** Set the captured picture resolution.

**[Image Quality]** Choose the picture quality, there are 6 range to choose.

**[Snapshot Frequency]** Support 1sec./pcs.~8sec./pcs 8 ranges of snapshot to choose.

### 4) **Network**

Wi-Fi camera supports both Wi-Fi network and LAN network, this page is for Wi-Fi.

**[Channels Choose]** Choose one channel.

[DHCP] Automatic get the IP address.

[IP Version] Choose the internet protocol version, IPV4 /IPV6.

[IP Address][Subnet Mask][Gateway] Set IP address, subnet mark and gateway for the device.

[First DNS Server] Set DNS server IP address.

[Alternate DNS Server] Set standby DNS server IP address.

[MAC/Serial] Show MAC address of front device.

## 5) **Detection**

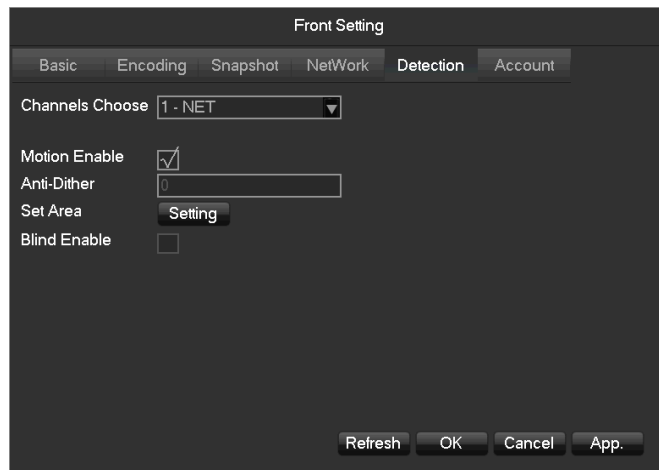

[Channels Choose] Choose one channel.

[Motion Enable] Enable the motion detection alarm or not.

[Dejitter] Only record one alarm event in this time, the default is 5sec.

[Set Area] Set the motion detection area. There are 396 (22\*18) regions can be set.

There are 6 sensitivity levels for motion detection.

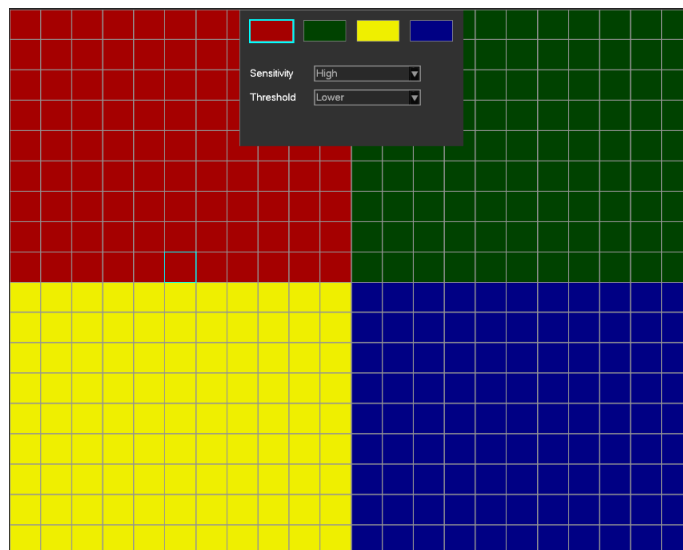





The network protocol selected when connecting the IPC must supporting to configurate this feature. All the settings are for front device.

**[Blind Enable]** Enable the blind detection alarm or not.

## 6) **Account**

To get the IPC's account list.

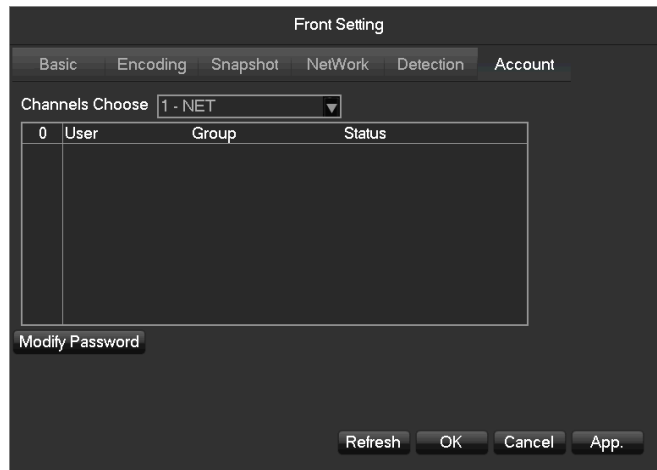

If the current account is administrator will get the whole account list, or can't get the other accounts information.

## 9.4.1.6 Basic Setting

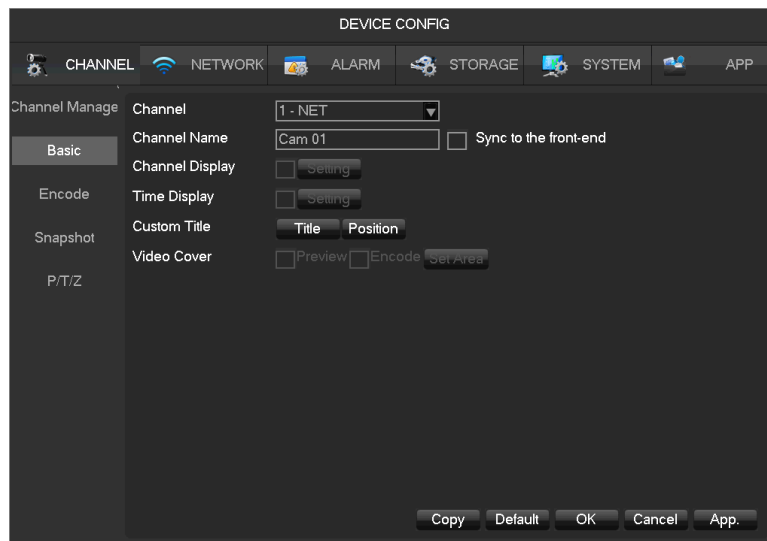

**[Channel]** Select the desired channel.

**[Channel name]** Select the channel name.

**[Channel display]** Set the position of the channel title.

**[Time display]** The position of the time title on the screen.

[**Time Synchronization**] Time synchronization of network channels and the device.

[**Custom Title**] Customized title and location.

[**Video cover**] Set protected area of previewing and recording.

### 9.4.1.7 Encode Setting



[**Channel**] Select the desired channel.

[**Compression**] H.264 / H.265.

[**Resolution**] The resolution of main stream and sub stream. Different channels correspond to different resolutions. Frame rate setting range is also different.

[**Frame Rate**] 1fps-20fps.



*Resolution and frame rate are vary depending on NVR model.*

[**Bitrate Control**] Constant Bit rate or Variable Bitrates. Bit rate can be set as Constant Bit Rate (CBR).

There are 6 levels for image quality in Variable Bit Rate (VBR), 6 is the best but it has to be fixed to Constant Bit Rate when selected.

### 9.4.1.8 Snapshot

Store an image snapshot from the camera(s) when the alarm has been triggered.

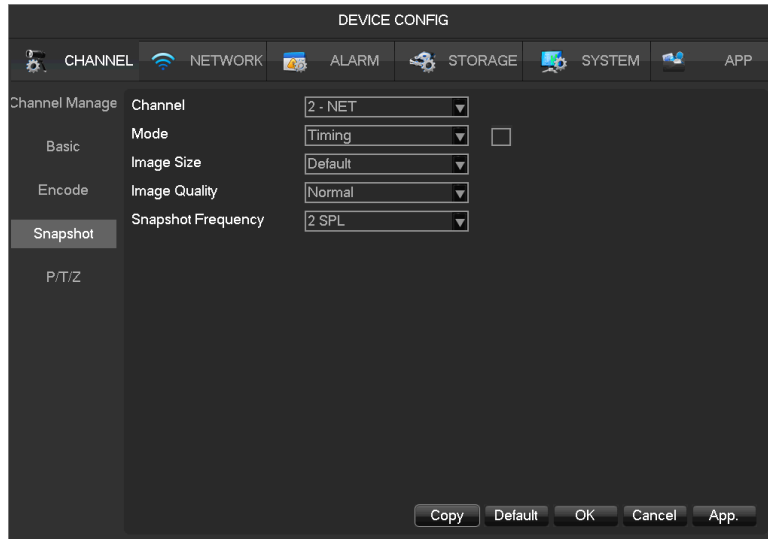

**[Channel]** Select a channel.

**[Mode]** Trigger: When this option is set the NVR will capture an image snapshot as the alarm gets triggered.

**[Image size]** Choose different resolution for snapshot.

**[Image Quality]** There are 6 levels of quality.

**[Snapshot frequency]** set highest capture rate for single channel, 1/2/3/4/5/6/7/8 s/p.

### 9.4.1.9 P/T/Z

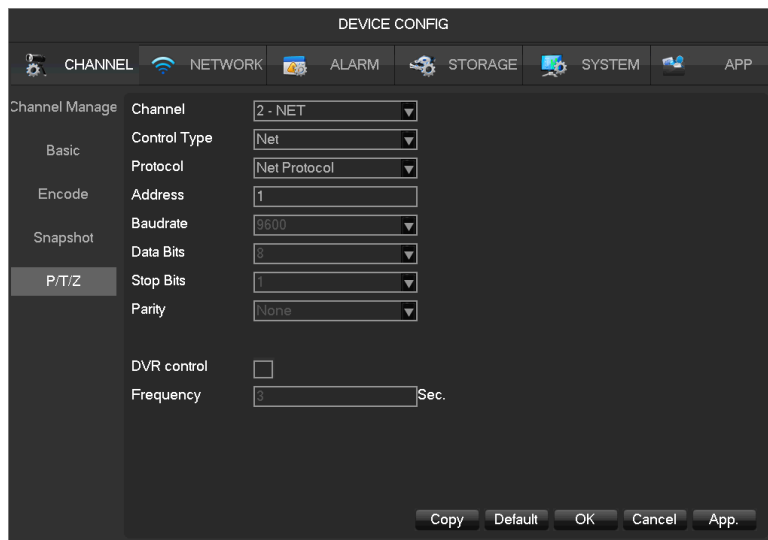

**[Channel]** Select the PTZ channel to set.

**[Control Type]** NET, based on the channel type.

**[Protocol]** Select the PTZ protocol (e.g. Net Protocol).

**[Address]** The PTZ's address.

**[Baudrate]** The PTZ's baudrate, can find it in the PTZ OSD, the default is 9600.

**[Data Bits]** Default is 8.

**[Stop Bits]** Default is 1.

**[Parity]** Default is none.

**[DVR Control]** Enable it can virtual the PTZ features.

**[Frequency]** Default is 3sec. The value range is 1~30secs.

## 9.4.2 Network

This menu section allows you to configure the network settings of the NVR. It is recommended that an experienced network technician should only be able to configure settings in this menu section.

### 9.4.2.1 Basic

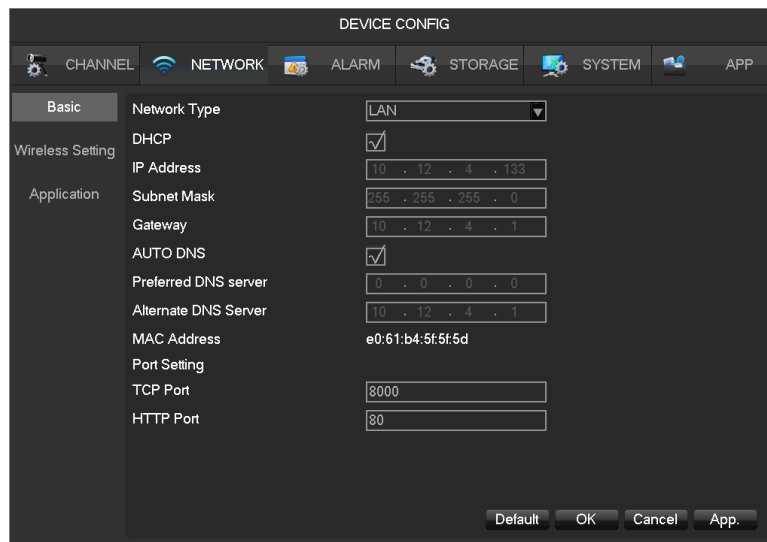

The screenshot shows the 'DEVICE CONFIG' window with the 'NETWORK' tab selected. The 'Basic' sub-tab is active, displaying various network configuration options. The 'Network Type' is set to 'LAN'. The 'DHCP' checkbox is checked. The 'IP Address' is set to '10 . 12 . 4 . 133', 'Subnet Mask' to '255 . 255 . 255 . 0', and 'Gateway' to '10 . 12 . 4 . 1'. The 'AUTO DNS' checkbox is checked, with 'Preferred DNS server' set to '0 . 0 . 0 . 0' and 'Alternate DNS Server' set to '10 . 12 . 4 . 1'. The 'MAC Address' is 'e0:61:b4:5f:5f:5d'. The 'TCP Port' is '8000' and the 'HTTP Port' is '80'. At the bottom, there are buttons for 'Default', 'OK', 'Cancel', and 'App.'.

Category	Setting	Value
Basic	Network Type	LAN
Wireless Setting	DHCP	<input checked="" type="checkbox"/>
Application	IP Address	10 . 12 . 4 . 133
	Subnet Mask	255 . 255 . 255 . 0
	Gateway	10 . 12 . 4 . 1
	AUTO DNS	<input checked="" type="checkbox"/>
	Preferred DNS server	0 . 0 . 0 . 0
	Alternate DNS Server	10 . 12 . 4 . 1
	MAC Address	e0:61:b4:5f:5f:5d
Port Setting	TCP Port	8000
	HTTP Port	80

**[DHCP]** Enable the NVR to obtain an IP address automatically. If it is enabled, the NVR will reboot and search for a DHCP server, and then assign a dynamic IP address. The dynamic IP address will be displayed in the menu. Enter a static IP address if there is no DHCP service available. If you are using the advanced feature PPPOE, then the IP/mask/gateway and DHCP are unable to be changed.

**[IP Address]** Use (▲▼) or input numbers to modify IP, then set **[mask]** and **[gateway]** for this IP.

**[AUTO DNS]** Get the DNS from the DNS server automatically.

**[First DNS Server]** DNS server IP address.

**[Alternate DNS Server]** DNS alternate IP address.

**[Physical Address]** Physical address of current net port.

**[HTTP Port]/[TCP Port]** Most is used for net connection.

### 9.4.2.2 Wireless Setting

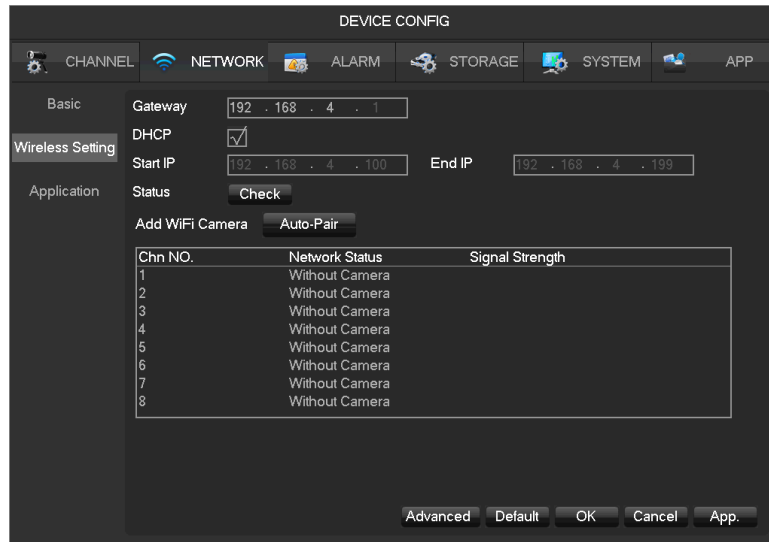

[Gateway] Wi-Fi gateway, default is 192.168.4.1, you can change the segment.

[DHCP] Enable the DHCP, then will assign IP address to Wi-Fi camera automatically.

[Start IP]/[End IP] The IP address pool which Wi-Fi cameras can use.

[Status] Wireless channels healthy.

[Add WiFi Camera] Add new Wi-Fi camera into the kit, see **Chapter 4 Configuring the IP camera to work on the NVR** for further instructions.

### 9.4.2.3 Application

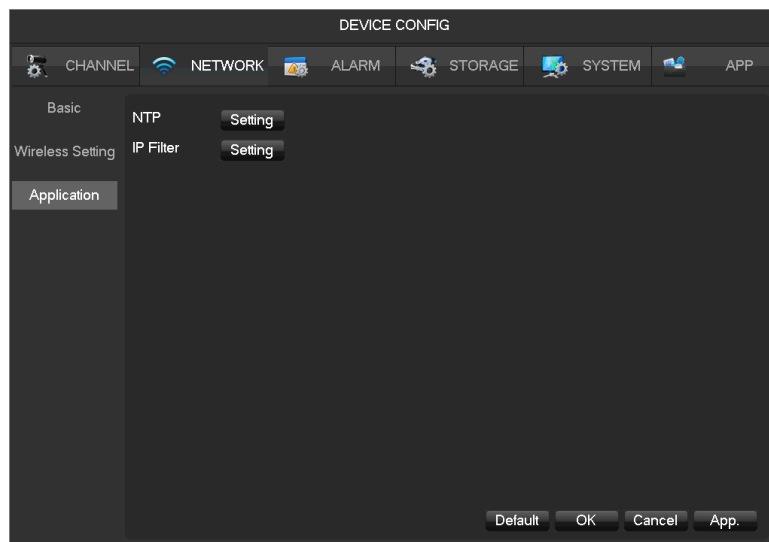

[NTP] Select Enable switch to turn on the NTP protocol support, can be with SNTP communication server to realize automatic calibration function.

**NTP**

Server IP   Enable

Port

Update Period  min.

- **[Host IP]** Enter the IP of NTP service NTP, default is windows NTP server.
- **[Port]** Supports TCP transport only, port is limited only 123.
- **[Update Period]** Interval time is 1 minute or more, the maximum update period is set to 65,535 minutes.

**[IP Permissions]** For permission to access the DVR IP rights management. When choosing the white list, the list indicates that only the IP to connect this DVR. Up to 64 IPs. If the selected item is not ticked, no restrictions on accessing to the device's IP.

**IP Filter**

Restricted Type   Enable

### 9.4.3 Alarm

Support video detect, external alarm detect, and abnormality alarm.

#### 9.4.3.1 Video Detection Configuration

The video detection includes motion detection, video lost, video blind and VQD (video quality detectio).

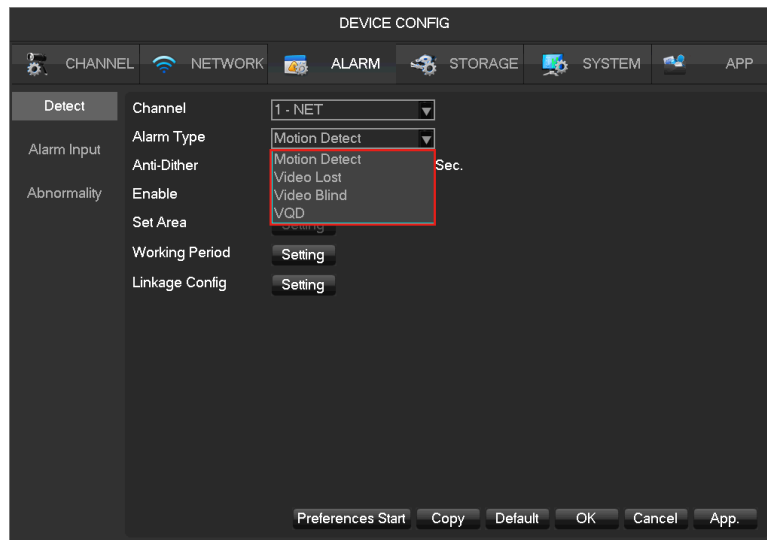

**[Channel]** Select a channel.

**[Alarm Type]** Motion detection, video lost, video blind and VQD.

**[Motion Detection]** Detect the motion in the picture, and send alarm according to setting.

**[Video Lost]** Detect the video loss and send alarm according to setting.

**[Video Blind]** Detect the video which was covered and send alarm according to setting.

**[VQD]** Analysis the video quality, if virtual, camera move or color cast, then will alarm based on the alarm plan.

**[Anti-Dither]** Will only alarm one time during this time, the default is 5sec.

**[Enable]** Enable the alarm or not.

**[Set Area]** There are totally  $22 \times 18 = 396$  area can be set, support 4 kinds of sensitivity.

- **[Sensitivity]** Highest, higher, middle, low, lower, lowest.

**[Working Period]** Set the alarming schedule.

**[Linkage Config]** Set the alarm linkage and the handling method.

**[Preferences End]** It will show a test on the current setting.

**[Copy]** Copy the setting to other channels.

### 9.4.3.2 Alarm Input

Alarm come from IP cameras.

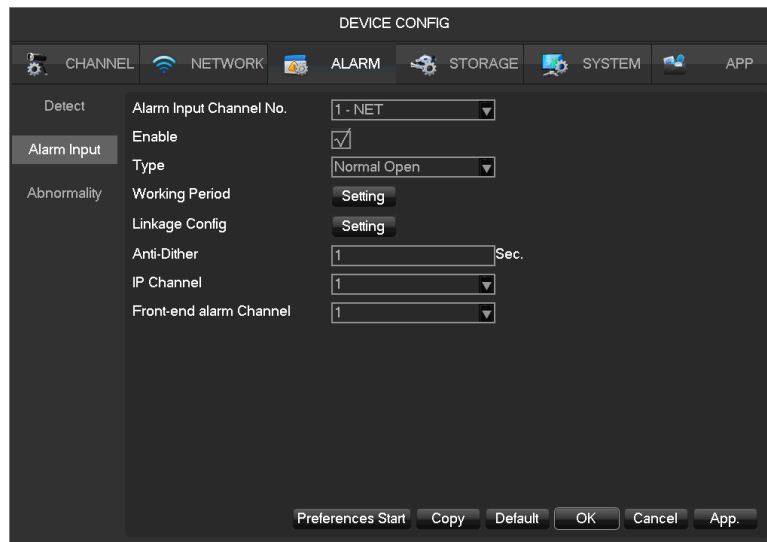

**[Alarm Input Channel No]** Select a channel.

**[Enable]** Control the open and close of alarm.

**[Type]** Choose Normal open and Normal close.

**[Working Period]** Set the alarming schedule.

**[Linkage Config]** Set the alarm linkage and the handling method.

**[Anti-Dither]** Will only alarm one time during this time, the default is 1sec.

**[Front-end alarm Channel]** If IP camera supports more than 1 alarm in, then should choose which for this net channel.

**[Copy]** Copy the setting to other channels.

### 9.4.3.3 Abnormality

Provide multiple equipment abnormal monitoring function, and it can do the corresponding alarm linkage of equipment abnormal events.

**[Main Menu]-[Alarm]-[Abnormality]** Enter the configuration interface as shown in the figure below:



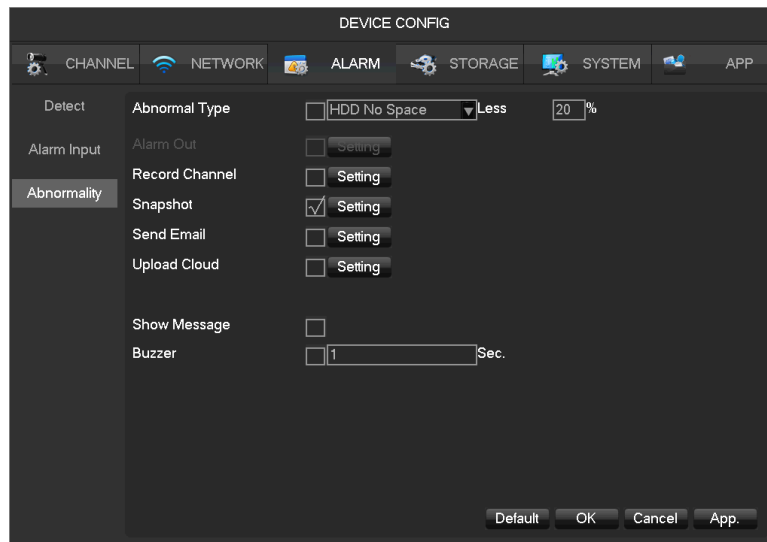

### [Exception type]

- [No HDD] Alarm when HDD is not present or cannot be detected.
- [HDD No Space] Alarm when hard disk capacity is lower than setting.
- [Off Network Events] Alarm when network is not connected.
- [IP Conflict] Alarm when IP address conflict.
- [HDD Error] Alarm when there is error in reading and writing hard disk.

[Alarm Output], [linkage record], [snapshot], [Send Email], [show message], [Send to network drive],

[buzzer] Regarding linkage setting, see **Chapter 11.1 ‘Alarm Linkage Setting’** for future instructions.

## 9.4.4 Storage

### 9.4.4.1 HDD Manage

Show the HDD space and status.

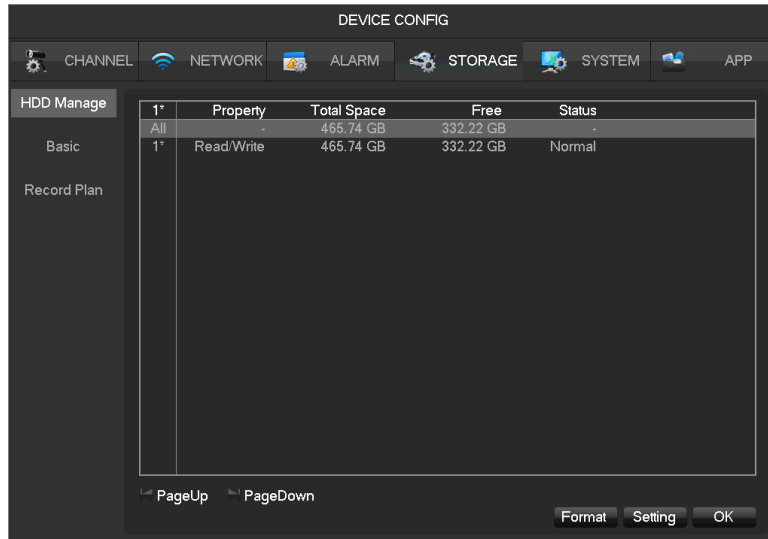

 *Hard disk format operation results in the loss of video data.*

[Set] Set HDD as read-write, read only or redundancy mode. Video data can be protected from covering under read only mode. It supports HDD S.M.A.R.T smart detection at the same time.

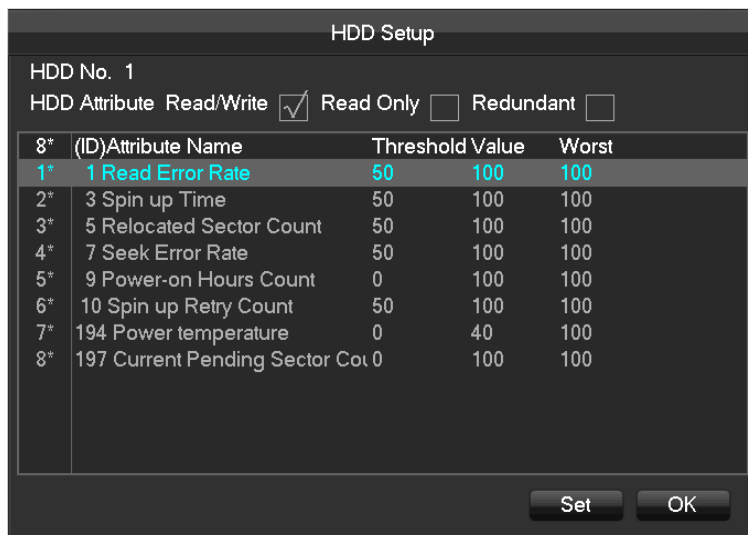

### 9.4.4.2. Basic

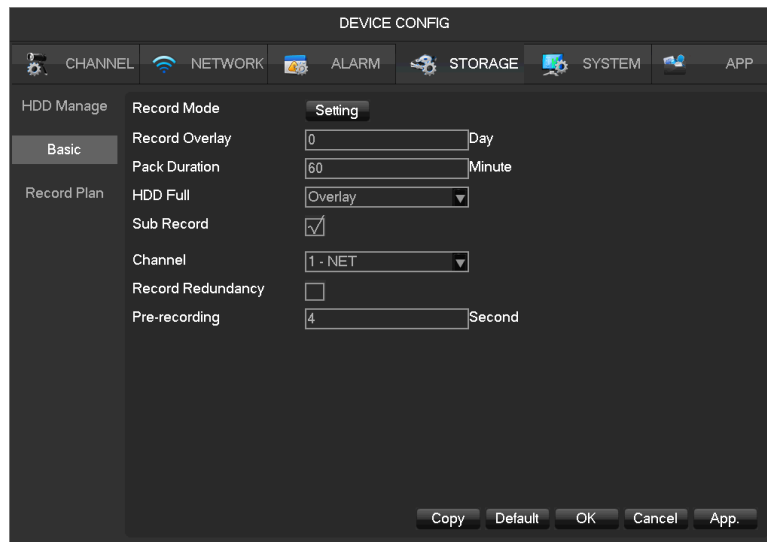

**[Record Mode]** Support three modes, ‘record automatically’, ‘manually’ or ‘not record’.

**[Record Overlay]** The range is 0~31.

**[Video Package Time]** The figure is between 5 to 120 minutes.

**[HDD Full]** Overwrite or stop recording.

**[Sub Record]** Sub-stream recording switch. Enable it, then will recording with sub-stream and main stream.

**[Channel]** Select a channel.

**[Video Redundancy]** Open or close the redundant recording.

**[Pre-recorded]**The figure is between 0 to 30 seconds, default is 4 seconds.

### 9.4.4.3. Recording plan

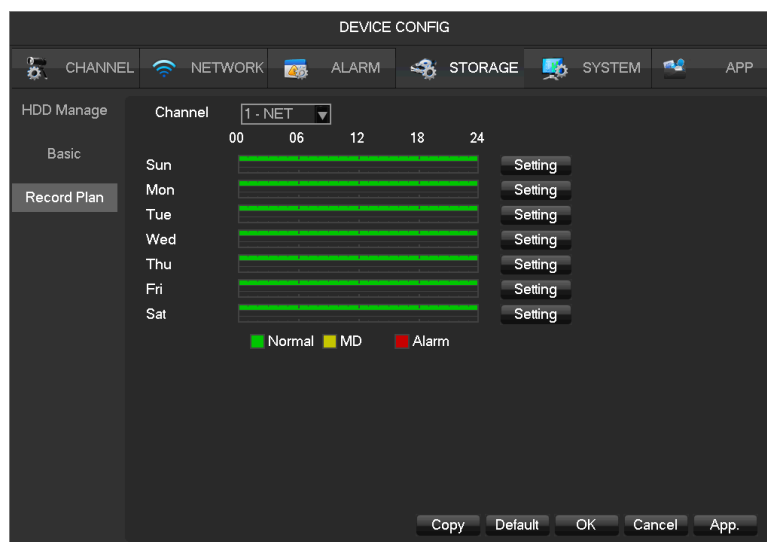

**[Channel]** Select a channel. Green shows normal recording, Yellow shows motion detection, and Red shows Alarm. Users can set or change setting according to date.

**[Setting]** Select recording method.

Record Type	Normal	MD	Alarm
Period 1 00 : 00 - 24 : 00	<input checked="" type="checkbox"/>	<input type="checkbox"/>	<input type="checkbox"/>
Period 2 00 : 00 - 24 : 00	<input type="checkbox"/>	<input type="checkbox"/>	<input type="checkbox"/>
Period 3 00 : 00 - 24 : 00	<input type="checkbox"/>	<input type="checkbox"/>	<input type="checkbox"/>
Period 4 00 : 00 - 24 : 00	<input type="checkbox"/>	<input type="checkbox"/>	<input type="checkbox"/>
Period 5 00 : 00 - 24 : 00	<input type="checkbox"/>	<input type="checkbox"/>	<input type="checkbox"/>
Period 6 00 : 00 - 24 : 00	<input type="checkbox"/>	<input type="checkbox"/>	<input type="checkbox"/>

Select All  
 Sun  Mon  Tue  Wed  
 Thu  Fri  Sat

OK Cancel App.

- **[Period]** Set the recording period, there will be 6 period to choose.
- **[Regular]** Regular recording.
- **[MD]** Motion detection recording.
- **[Alarm]** Alarm recording.

**[Copy]** Copy the setting to other channels.

## 9.4.5 System Configuration

### 9.4.5.1 Basic setting

Get into the **[Basic]** menu under **[Device Config]**

Basic	System Time	2018 - 06 - 01   14 : 11 : 05
Display Output	DST	<input type="checkbox"/> Setting
Maintain	Date Format	YYYY MM DD
Account	Date Separator	.
Default	Time Format	24-HOUR
Upgrade	Time Zone	GMT+08:00
Toolbar	Language	ENGLISH
	Auto Logout	10 min.
	DVR No.	8
	Video Standard	NTSC
	Startup Wizard	<input checked="" type="checkbox"/>
	Device Name	NVR2208L-W

Default OK Cancel App.

**[System Time]** Set the HD record system time.



*please click the "save" button to save the time after setting.*

**[Daylight Saving Time (DST)]** Enable the function and click "Set" to enter the local DST starting and ending time setting.

**[Date Format]** Modify the date display format.

**[Date Separator]** Select the separator for date.

**[Time Format]** 24 hour or 12 hour display mode.

**[Time Zone]** Select the time zone.

**[Language]** Select language (different models have different language choice).

## 9.4.5.2 Display Output

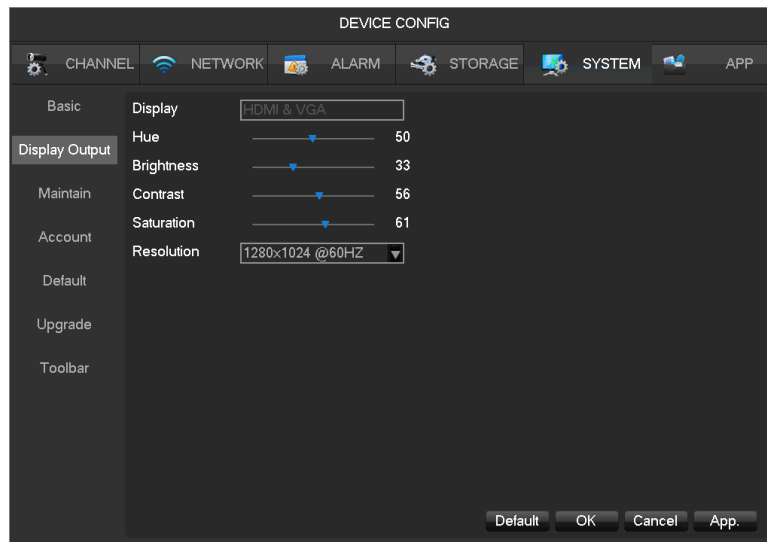

**[Display]** HDMI&VGA

**[Resolution]** Select the VGA output resolution and refresh rate.

**[Enable Tour]** Enable switch.

**[Interval]** Tour interval time is 5-120s.

**[View]** It includes single screen, four-, nine-, sixteen-screen.

**[Motion Tour]** Set the motion detection tour mode.

**[Alarm Tour]** Set the alarm tour mode.

### 9.4.5.3 Maintain

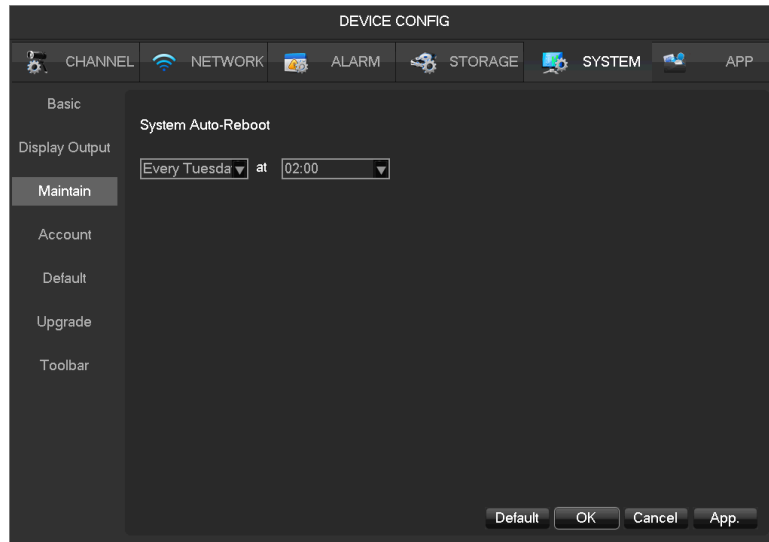

[Auto maintain] Set the desired the project of automatic maintenance.

### 9.4.5.4 Account

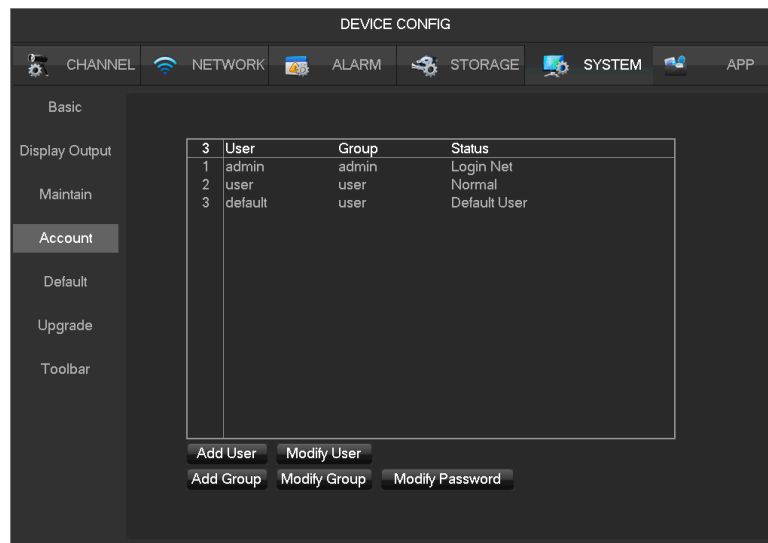

[Add User] Increase users within the group and settings user access control.

[Modify User] Modify the user and settings user access control.

[Add Group] Add group and settings group access control. Enter into the menu interface of Increase the group, determine the group name, select 83 access control, left click mouse button to confirm, save the new user group.

[Modify Group] To modify the group attribute which already exists.

[Modify Password] To modify password.

- Select the user, enter old password then enter new password and confirm
- Click **[confirm]** button to make sure modify password.
- The password can be set 1-6. Beginning and ending spaces is invalid password, you can have a space in the middle.
- Users which has User Account Control permission can change their own passwords, can also modify other users' passwords.



- *The following user names and user group names, etc., character and length consisting up to six bytes, the invalid string is trailing spaces. Legal characters: letters, numbers, underscores, minus sign, point, other characters are not allowed to use.*
- *the number of users and groups is not limited, User Group increased or delete according to user-defined: The factory settings are user \ admin two groups. Users can set their own related group, the group of users can be freely re-assign permissions at the group permissions.*
- *user management using two methods of user and group, Group name and the user name cannot be repeated, each user must belong to a group, a user can belong to only one group.*
- *There are three users: admin, user, and hidden default initialization. The factory password for first two are 123456. Admin default user permissions are high at the factory, and the factory default user as a low privileged user, only for monitoring, playback.*
- *Hidden default: This user system for internal use and cannot be deleted. When local is in "no user is logged" state, the system will automatically log in with this account. Users can modify this account permission to do what free login can do.*
  - *Enter to the menu interface of increase user, Enter your user name and password, select belongs to which group, and select whether to reuse this user. Reuse means that the account can be used simultaneously, multiple clients can use the account. ◦*

*Once the group belongs selected, the user's permissions only a subset of the group, not ultra vires the properties of the group.*

### 9.4.5.5 Default

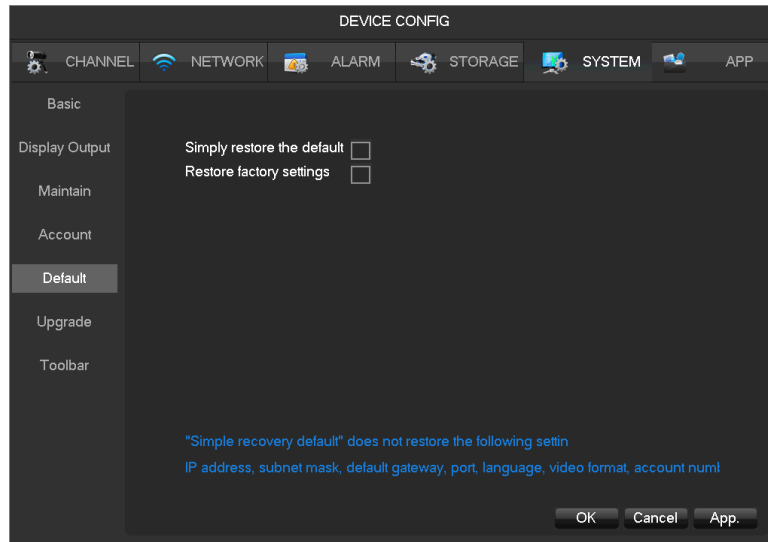

System back to the default configuration factory state (specific items recovered optional)



*simply restore the default won't restore the following setting:*

- *IP address, mask, gateway, port*
- *Language*
- *Video format*
- *Account and password.*

### 9.4.5.6 Upgrade

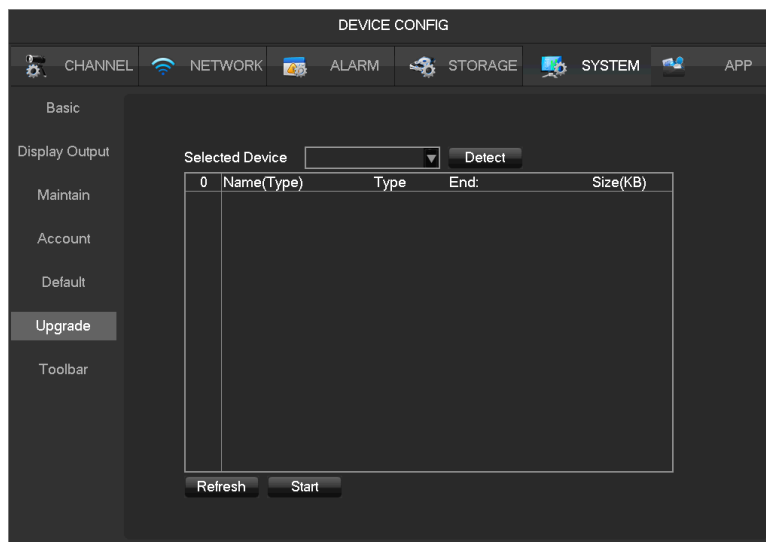

System software can be upgraded: Insert a USB storage device, click Upgrade.





System upgrade may cause the NVR can not start properly, please Operation under the guidance of the company's technical staff.

## 9.4.6 APP Center

### 9.4.6.1 DDNS

Dynamic DNS is a kind of system which point internet domain name to variable IP. According to the rule of internet domain name, domain name must associate with the fixed IP address. Dynamic DNS provide a fixed Name server for the dynamic domain, and then guide the domain search to the IP address of dynamic user through Name server, which can make the outside user connect to the dynamic user's URL.

The screenshot shows the 'DEVICE CONFIG' window with the 'DDNS' tab selected. The configuration fields are as follows:

Category	Field	Value
DDNS	DDNS Type	FNT DDNS
	Enable DDNS Register	<input type="checkbox"/>
Email	Domain Name	faceaip.net
	User Name	
P2P	Password	
	Server IP	faceaip.net
Cloud Storage	Port	39012
Push	Status	Not Connected...

Buttons at the bottom: OK, Cancel, App.

#### 1) FNT DDNS

FNT DDNS is built-in professional dynamic DNS service in our network DVR. You can register directly in the device .Specific steps are as following.

**[Main menu]-[APP]-[DDNS], choose FNT DDNS.**

- Select FNT DDNS and Enabled it.
- Input one user name, there will be a domain name generated auto. Domain name = user name.faceaip.net.
- Input the password
- Click “Register” button. If the domain name is not registered, it will pop up a message that connect DDNS server successfully otherwise it will prompt that the registration is failed.



*Suggestion: you'd best change the DNS server in basic configuration to the router's DNS server*

- Click the “ok” button to complete the settings.

## 2) No-IP DDNS

Register new account at [www.no-ip.com](http://www.no-ip.com).

### Embedded NVR Setting:

- Open [Main Menu]-[APP Centre]-[DDNS], choose NO-IP DDNS.
- Refer to the following configuration:

Name	Configuration
DDNS type	NO-IP DDNS
Host IP	dynupdate.no-ip.com
port	80
Domain name	xxx.xxx.org (xxx: domain name created)
User name	xxx (user name registered)
password	xxxxxx (password registered)

## 3) Dyndns DDNS

Register new account at [www.dyndns.com](http://www.dyndns.com).

### Embedded NVR Setting:

- Open [Main Menu]-[APP Centre]-[DDNS], choose NO-IP DDNS.
- Refer to the following configuration:

Name	Configuration
DDNS type	Dyndns DDNS
Host IP	Members.dyndns.org
port	80
Domain name	xxx.xxx.com (xxx: domain name created)
User name	xxx (user name registered)
password	xxxxxx (password registered)

## 9.4.6.2 Email

DEVICE CONFIG

CHANNEL NETWORK ALARM STORAGE SYSTEM APP

DDNS SMTP Server MailServer  Enable

Email Port 25

Anonymous

P2P User Name

Password

Cloud Storage From

Encryption None

Push Title DVR ALERT

Receiver

Receiver

Receiver

Event Interval 0 Sec.

Test

OK Cancel App.

See Chapter 11.1.8 ‘Send Mail’ for future instructions.

## 9.4.6.3 P2P

DEVICE CONFIG

CHANNEL NETWORK ALARM STORAGE SYSTEM APP

DDNS Enable OPEN

Email Transfer Mode None

Account Reuse

P2P Device ID 004b0017

Password iLMTO0

Local Port 3000

Cloud Storage

Push P2P Server URL http://www.vssweb.net

Status Online Ping Diagnose

NAT Server Address NULL

QR Code

OK Cancel App.

**[Enable]** Open/Close P2P function.

**[Transfer Mode]** Network transfer strategy, choose Quality priority or Fluency priority.

**[Account Reuse]** Enable it supports multiple users log in the same device.

**[Device ID]** Display device ID.

**[Password]** Device password.

**[Local Port]** Set local port.

**[P2P Server URL]** P2P server URL.

[State] Current connection state.

## 9.4.6.4 Cloud Storage

DEVICE CONFIG

CHANNEL NETWORK ALARM STORAGE SYSTEM APP

DDNS

Email  Dropbox  
 Google Drive

P2P Upload Path

Cloud Storage

ALARM

Push Channel 1 - NET  
Source Motion Detect  
CloudStorage   
Snapshot   
Linkage Config Select

Copy OK Cancel App.

See Chapter 11.1.10 'Send NetDisk' for future instructions.

## 9.4.6.5 Push

DEVICE CONFIG

CHANNEL NETWORK ALARM STORAGE SYSTEM APP

DDNS

Email Message   
Picture   
P2P Time Lag 60s Test

Cloud Storage

Push Info

Event External Alarm Emergency Level Middle  
Device Status Device Start High

OK Cancel App.

See Chapter 11.1.9 'Server Push' for future instructions.

# 10 WEB Access

## 10.1 WEB Operation

### 10.1.1 Network Connection

Check whether the DVR is on the network by checking B-Lamp on front panel, light indicates connection, otherwise connection error.

Set IP, subnet mask and gateway for computer and DVR. Please assign the same segment IP address without router, need to set the appropriate subnet mask and gateway with router.

The detail of DVR network configuration please see [Configuration]-[Network Setting].

Ensure the IP is correct and check whether the DVR is on the network by using the Windows command “ping”.

### 10.1.2 The control installation and the user login logout

Users can remote access to DVR by Internet Explorer, assuming you have a correct network configuration.

The following interface will pop up when you access the IP address in Internet Explorer.

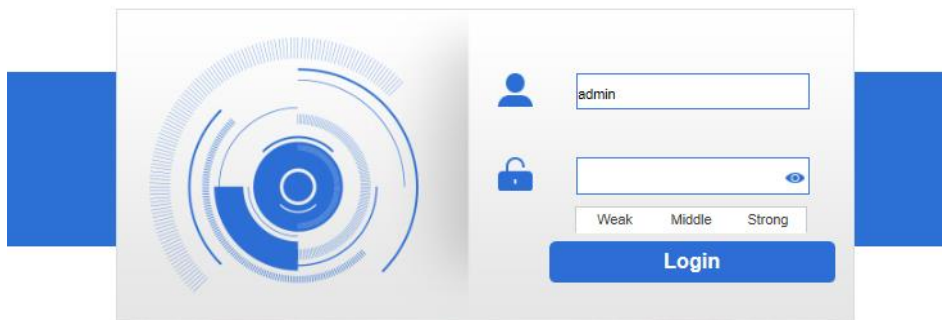

The following interface will pop up when you log in.

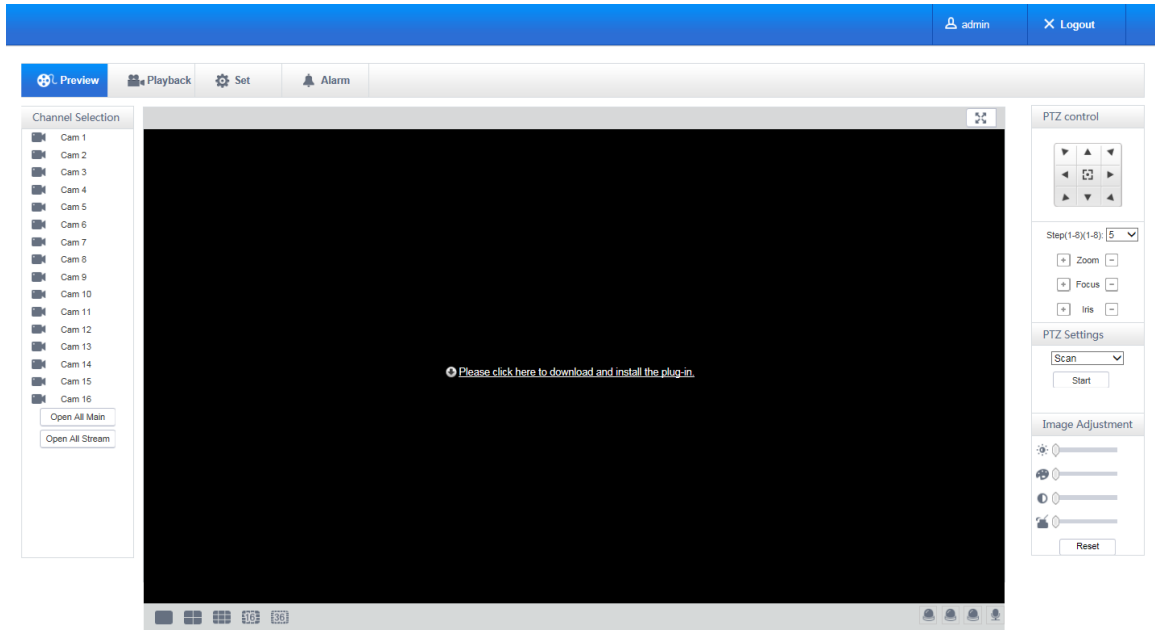

Will be displayed in Compatibility View option is checked on all websites.

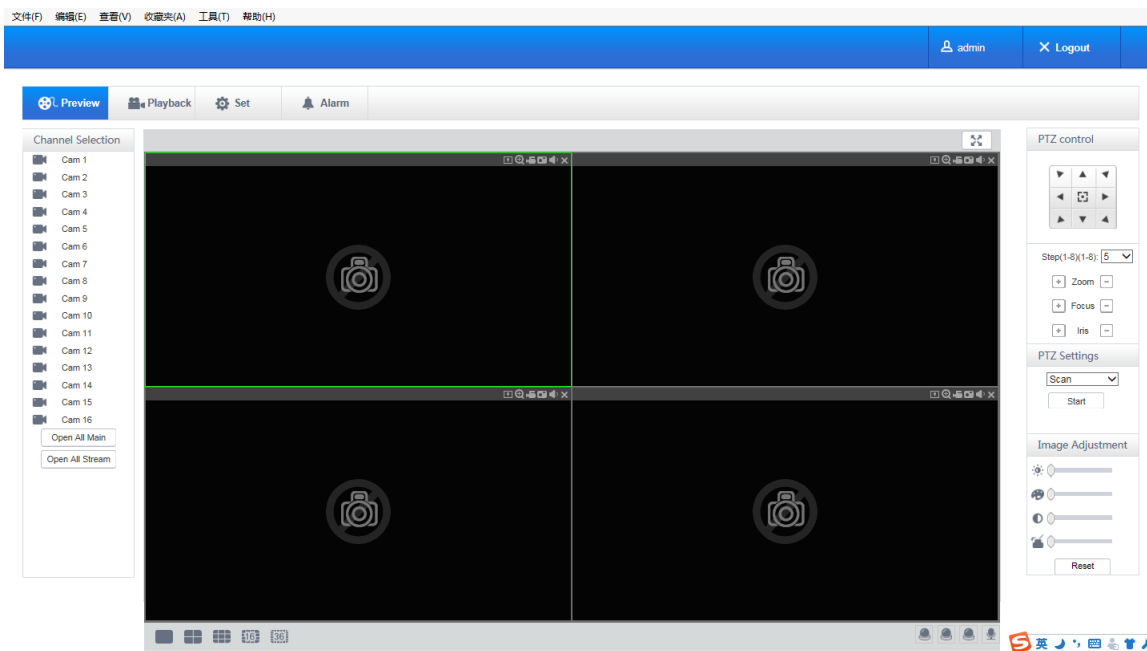

### 10.1.3 The Interface of Web Operations

#### WEB Interface Description

After log in the web, the preview interface will pop as following:

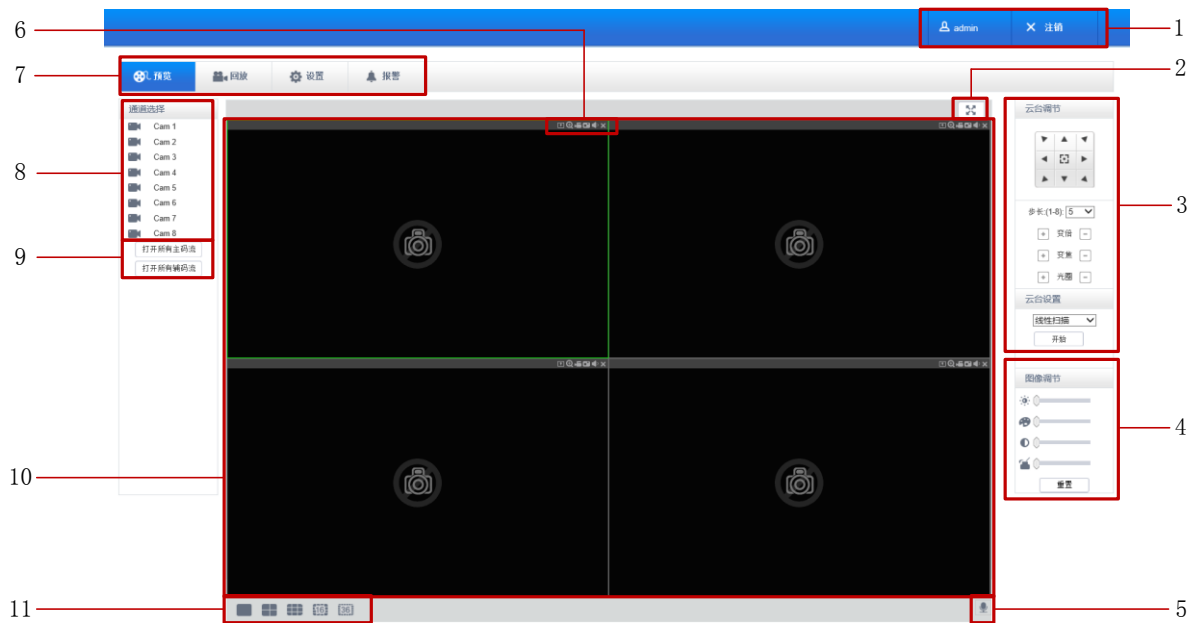

### WEB Interface

#### Description

Index	Name	Description
1	Log out	Show the current login user, click on log out
2	Full Screen	Full screen preview
3	PTZ control	PTZ control menu
4	Image color & other saturation	Image color: modify brightness, contrast and Other: set capture path, record download path and reboot
5	Device function key	Two way talk function key and etc.
6	Channel function key	screenshots, electronic amplification function keys and etc
7	Menu	System configuration, record search, alarm setting, exit, etc.
8	Channel Selection	Realtime channel preview selection
9	All open key	Open all can be open all channels real-time monitoring (main/auxiliary stream) in the video monitoring window
10	Surveillance window	Real time recording or playback
11	Channel segmentation window	Provide the single picture, 9, 4 picture image segmentation method.

#### Select the focus window

Into the WEB interface, select the focus window in live window, the focus window has a light green border.

#### Preview Channel Selection

The left channel column is as following picture:

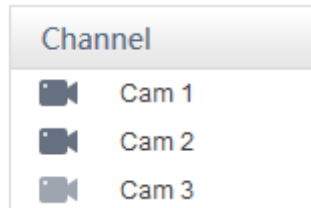

Left-click on any channel, the focal channel open with the main stream, and channel focus automatically moves to the next channel.

After opening the live video, the left channel column is as following picture:

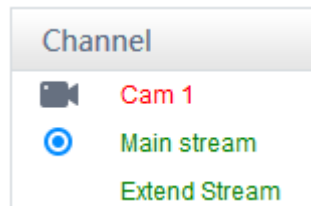

### The Real-time Monitoring





Preview window's Lower left corner shows the current video channel name.

Preview window's Upper right corner shows the current video time information.

Upper left corner shows the current DVR's IP, resolution, bit rate.

Upper right corner shows the function keys.

 Smart Information: Show the intelligent analysis information.

 Local Range: Video images can be enlarged.

 Local Record: Save and record video to a local HDD while in a live view. Set recording path in configuration.



 Capture: capture of the present channel, set the path in “other.

 Audio: on/off sound.

 Close video: off the focus window video.

## Screen split

Click “” (Lower left corner of the display window) to switch between single screen and multi-screen.

## PTZ Control

Set protocol (see [Setting]-[PTZ])

Control PTZ direction, step size, zoom, IRIS, preset, tour, pattern, border scan, light, wiper, auto pan, etc.

Step size controls PTZ direction and speed, e.g. step size 8 is moved faster than step size 1.

Eight direction rotations: up, down, right, left, up-left, up-right, lower left, lower right.

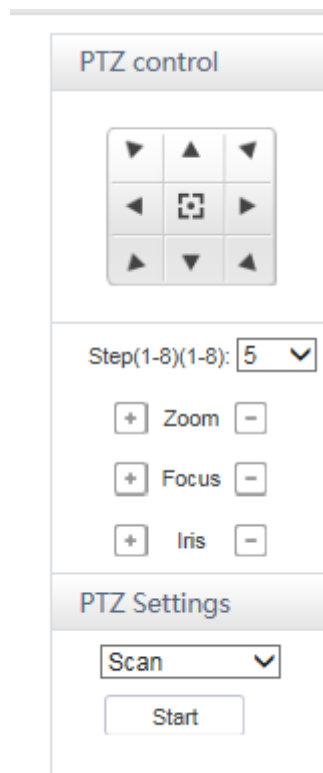

## Border scan

Operation: select the camera line scan of the left/right margin by direction button, and click the Settings button in the left /right margin position to determine the left border.

## Preset

Operation: modify preset position by direction button and inputting a preset number, then click “Add” to save.

## Tour

Operation: select “Tour”; Point between the first cruise line cruise input box value. And input numbers in “Path” and “preset”. Click[Add Preset]to add one preset in the cruise path, and repeat to add additional presets. Click [Clear Preset]to delete a preset, repeat to delete more.

## Pattern

Operation: Click “Pattern” in order to record an automated pattern. Then, go back to the PTZ controls in order to modify the zoom, focus and IRIS, etc. Stop recording in “Pattern” setting to save the pattern.

## AUX

On/off one of AUX.

## Wiper

On/off wiper under protocol.

## 10.1.4 Configuration

Access DVR local configuration menu by click “System Setting”, the further details please refer. [Local operation guide]

The screenshot displays the 'Set' configuration menu of a DVR system. The interface includes a top navigation bar with 'Preview', 'Playback', 'Set', and 'Alarm' options. The 'Set' menu is expanded to show 'Video Config' with sub-options: 'Channel Set', 'Remote Intelligence', 'Local intelligence', 'Network Settings', 'Event', 'Storage Management', and 'SYSTEM'. The 'Encoding' tab is selected, showing settings for 'Chn NO.' (1), 'Master Stream', and 'Sub-Stream'. The 'Master Stream' settings include: Coding mode (H.264), Resolution (1080P), Frame Rate(FPS) (25), Bit Rate Type (CBR), Reference Bit Rate (1280-8192Kb/S), and Bit Rate (4096). The 'Sub-Stream' settings include: Coding mode (H.264), Resolution (D1), Frame Rate(FPS) (25), Bit Rate Type (CBR), Reference Bit Rate (1000-2200Kb/S), and Bit Rate (2048). A 'Watermark Settings' section is also visible, with 'Watermark Character' set to 'Watermark'. At the bottom, there are 'Default', 'Refresh', and 'OK' buttons.

## 10.1.5 Search Record

Click [Playback] to open the search interface:

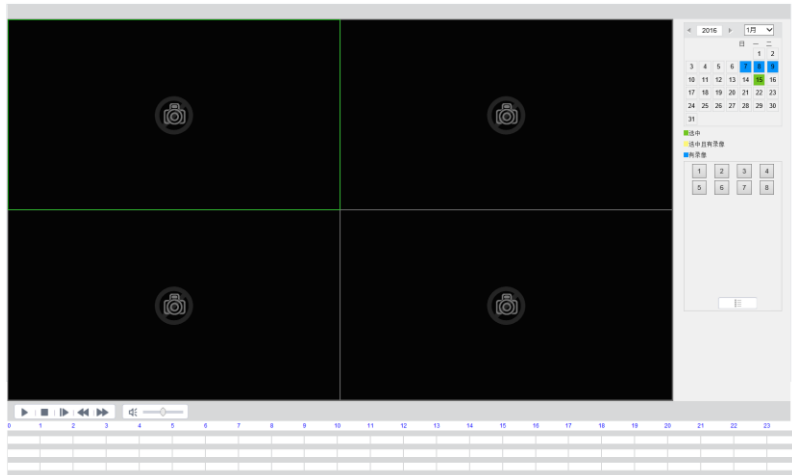

Up to playback 4 channels simultaneously.

### **Search record**

By selecting the record type, start and end times, and click the check button, get a list of files on the DVR.

Select the appropriate file and download can be played

### **Play**

Double click a search result to play in video window. Control the playing video by the control keys on the bottom. At this point, the bottom of the video window will display the video control buttons, video playback can be controlled.



### **Download**

Select a searched video to download to local. The download speed and percentage are displayed on the bottom of the screen.

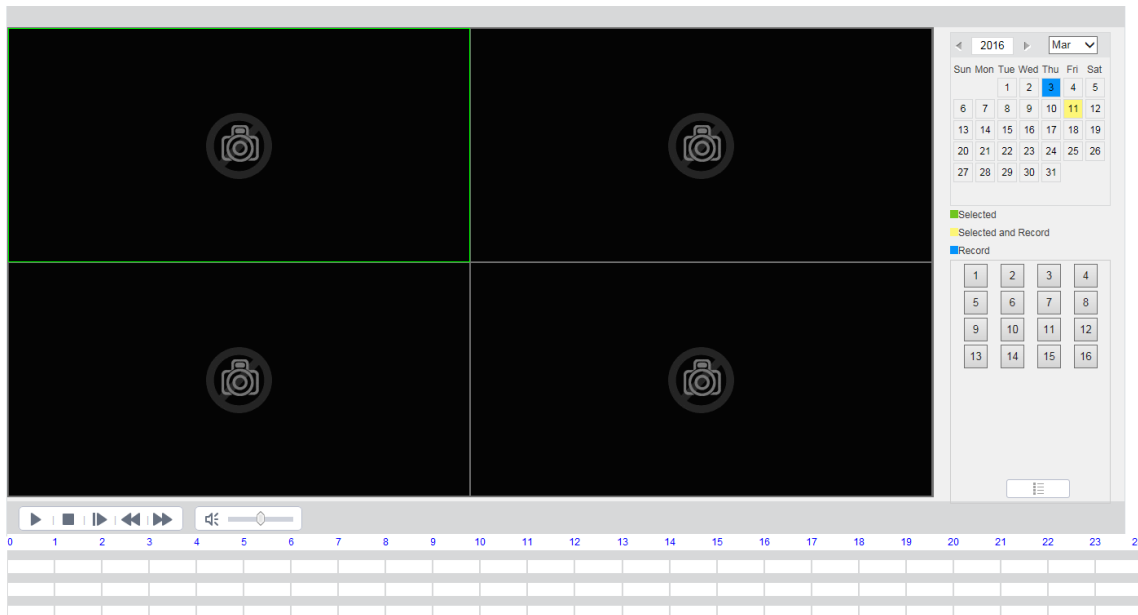

## 10.1.6 Alarm Configuration

Click the **[Alarm]** to enter the alarm setup menu:

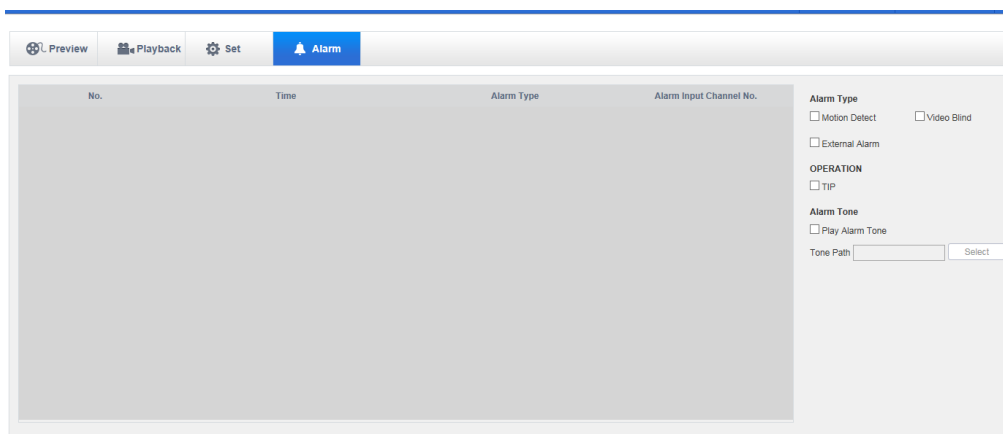

If need warning message displayed and real-time pop up on the WEB interface, open the **[monitor alarm]**, and select the appropriate type of alarm.

Choose type of alarm on menu, monitor video loss, motion detection, disk full, disk error, video mask, external alarm.

Click **[Video Pop-up]**, open the video loss, motion detection, hard disk full, hard disk failure, video block, video encoder alarm pop-up linkage.

Click **[prompt]** open the prompt: When an alarm occurs in real-time monitoring will popup alarm window menu.

Click **[Sound Pop-up]**, you can choose alarm tone pre-recorded on the local hard drive when an alarm

occurs, tone file in WAV format.

# 11 Appendix

## 11.1 Alarm linkage setting

Alarm linkage settings interface as following.

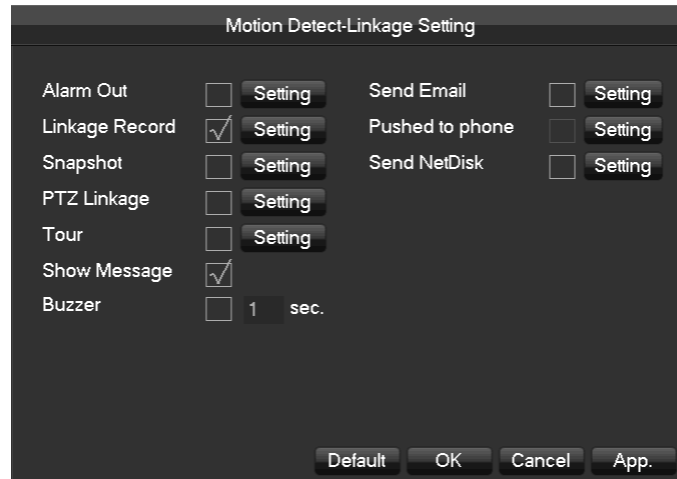

### 11.1.1 Alarm Out

Linkage the device alarm through the interface as following:



Support 10s-300s alarm-delay.

### 11.1.2 Linkage Record

Video channel linkage.

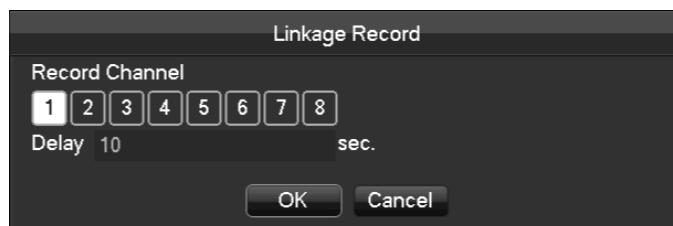

Support 10s-300s alarm-delay.

### 11.1.3 Snapshot

Screenshots through channel linkage as the interface following:

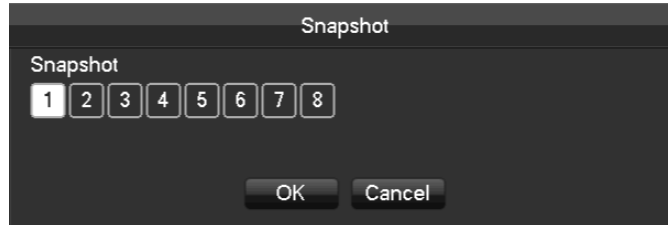

Configure the screenshots by setting [main menu]-[screenshot setting].



*If the access channel is the network channel, please check if the screenshot function is open of the camera.*

### 11.1.4 PTZ Linkage

Preset position, cruise, trace by setting the PTZ linkage.

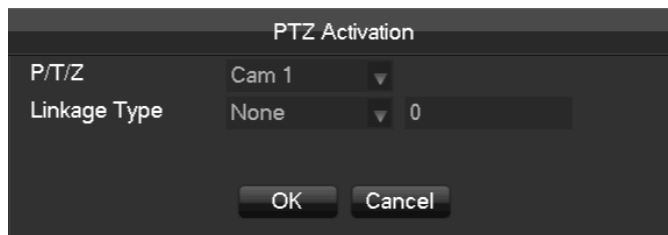

Preset position, cruise, trace by setting the PTZ configuration. See details on page 6.6.2.

### 11.1.5 Tour

Select the round tour channel when the alarm occurs, select the single channel to the round tour.

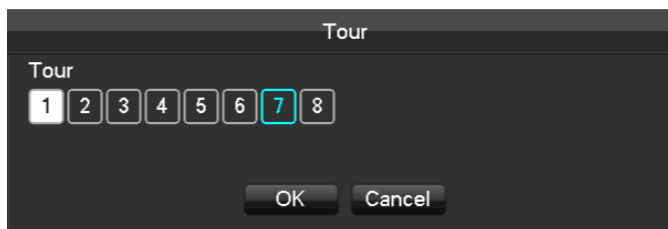

### 11.1.6 Show Message

Select the prompt to open the screen, if it occurs alarm, the preview screen will pop up the prompt as following:

Alarm Status

Alarm In	1	2	3	4	5	6	7	8	9	10	11	12	13	14	15	16
Video Lost	1	2	3	4	5	6	7	8								
Mask	1	2	3	4	5	6	7	8								
Motion	1	2	3	4	5	6	7	8								
Network	<input type="checkbox"/>	<input type="checkbox"/>														
IP Conflict	<input type="checkbox"/>	<input type="checkbox"/>														

### 11.1.7 Buzzer

Select the buzzer, the buzzer can last 1s-600s.

### 11.1.8 Send Email

Email configuration interface is as following:

CONFIG

CHANNEL NETWORK EVENT STORAGE SYSTEM APP

DDNS

Email

P2P

Cloud Storage

Push

SMTP Server MailServer  Enable

Port 25

Anonymous

User Name

Password

From

Encryption None

Title DVR ALERT

Receiver

Receiver

Receiver

Event Interval 0 Sec.

Test

OK Cancel App.

Configure the SMTP server, IP address, ports, user name, password and the email address of the sender, SSL/TLS encrypt the email, and support sending anonymous messages. The title of the email can support English and the Arab number, the maximum input characters reach as much as 32 characters.



## 11.1.9 Server Push

Server push configuration interface as following:

**[Send Message]** Open or close the mobile phone message sending.

**[Image Attachment]** Open the function of image attachment.

**[Time Lag]** Set the time lag of the message sending, 60s/90s/120s is optional.

**[Test]** Click Send to test the message sending function

**[Event]** Open or close the event sending, the events including external alarm, face detection, perimeter intrusion detection.

**[Device exception]** Open and close the device exceptional sending, the exception including the device startup, no hard dick, error hard dick, start recording/stop recording.

**[Urgency Degree]** The message sending level can be divided into High/Medium/Low level.

## 11.1.10 Send NetDisk

Choose Dropbox, Google drive, according to clew for binding.

Support motion detection, video occlusions, local alarm (face/perimeter ) alarm and other alarm types.

Can linkage other channels to upload the captured pictures

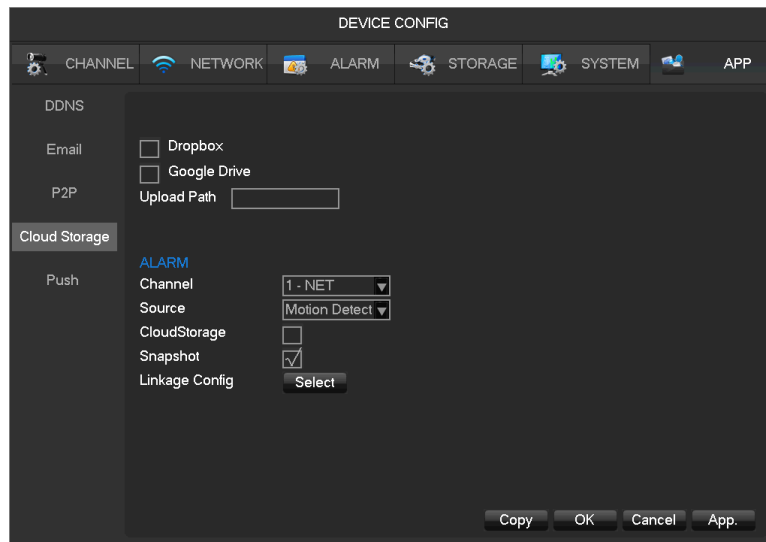

## 11.2 Port Mapping

Port mapping is mapping a port of outside web host's IP address to a machine inside web, and provide the service. When user connects to the port of the IP, the server will automatically map the request to the corresponding machine inside LAN. With this function, we can map many ports of a machine's IP address to different machines' different ports inside web.

The port mapping can also have other special agent functions, like POP, SMTP, Telnet and so on. Theoretically, it can provide more than sixty thousand ports. For example, if we want to map a web server which has an IP address of 192.168.111.10, we just need to input the IP address and TCP port 80 into the port mapping chart of the router.

There are two ways to map the port: UPnP function automatically map and modify the router's port mapping chart by manual.

### 11.2.1 UPNP Function

In order to get connection to the Embedded DVR through Public network, we need to set the Router to cross the NAT of Embedded DVR. UPnP can make the NAT cross automatically by the UPnP agreement of Embedded DVR, and don't have to set the Router.



*To realize the UPnP Function, there must be Router support and enable the UPnP Function.*

#### **The first step**

Connect the Router to the network, get to the Menu of the Router, set the Router, and enable the UPnP

Function.

Routers made by different manufacturers may have some difference, please refer to the specification carefully before setting the Router.

#### **The second step**

Connect the Embedded DVR to the Router; the configuration will automatically gain the IP address or static IP. After setting up the IP, click the Advanced. And get to the XXX, ports and multicast etc. choose to open the Enable at the **[UPnP port mapping]**

#### **The third step**

Enter into the Router management interface; detect the port if there is already a Port mapping. If there is, it shows UPnP setting's finished.

#### **The fourth step**

Input the IP address in IE, and add port number of the Embedded DVR, for example: 155.157.12.227:81. If you want to enter by the Client Software, use the TCP port offered by the outer net.



*If there are a few embedded DVRs need to set the UPnP function, in order to avoid IP conflict, set the ports of embedded DVR into different ports numbers. Otherwise, it will choose the embedded DVR port set preceded as the first choice.*

## **11.2.2 Port mapping Manually**

#### **The first step**

Connect the Embedded DVR to the Router, set the static IP.

#### **The second step**

Log in Router, enter into the configuration menu of Router, and set the menu. Then get to port, set the IP distributed by the Embedded DVR, and set the rule of port mapping, add HTTP and TCP port into mapping list.

Default access ports of Embedded DVR include HTTP port 80 and TCP port 8000, if the ports are occupied by the other device, please modify the default port of the Embedded DVR into other vacant ports.

#### **The third step**

Input the public net IP address in the IE, and add the port number of the Embedded DVR you want to access after the IP, for example: http://155.157.12.227:81. If you want to access by Client Software, you can use the outer net TCP port directly.



*For detail configuration setting, please refer to the user manual of Router.*

## 11.3 Voice Intercom

### 11.3.1 Summarize

Embedded DVR Bidirectional Talk: user can talk to remote client software or Web via DVR audio input and output ports; user can listen voice from Client Software and WEB via DVR audio output ports.

Two types of bidirectional talk ---- sharing and standalone ----for different models, exact info please refer to specifications.

### 11.3.2 Configuration

#### **Local configuration**

Connect a microphone to the MIC input port, connect loudspeaker to the audio output port.

If no standalone MIC input port, please connect microphone to the number 1 audio input port



*Local output needs active audio output device.*

#### **Remote PC Configuration**

Connect microphone and loudspeaker to computer.

Enable bidirectional talk in IMS software or WEB.

## 11.4 HDD S.M.A.R.T

### **S.M.A.R.T: “Self-Monitoring, Analysis and Reporting Technology”**

S.M.A.R.T HDD can analysis head, disc, motor, circuit operation, history and default security values via monitor instruction in HDD and surveillance software in host. Alarm will be sent to user automatically when the value is outside the scope of the security situation.

Detection parameters of Seagate HDD for example are divided into seven: ID detection code, Attribute Description, Threshold, Attribute Value, Worst, Date, and Status.

## 1、 ID detection code

ID detection code is not the only; manufacturer can use different ID code or increase or decrease its quantity according to the detected parameter's quantity.

For example: the ID detection code of WEASTERN DIGITAL's product is "04", parameter is Start/Stop Count, but the parameter of same code in Fujitsu's product is "Number of times the spindle motor is activated".

## 2、 Attribute Description

Attribute Description: name of detection item. Manufacturer can increase or decrease. As ATA standard update constantly, sometimes different models in same brand maybe different ,but must ensure major test items specified in S.M.A.R.T .(although different manufacturers have specific naming convention ,the essence of monitoring is the same.)

1 Read Error Rate

2 Spin up Time

4 Start/Stop Count

5 Relocated Sector Count

7 Seek Error Rate

9 Power-on Hours Count

10 Spin up Retry Count

194 Power temperatures

195 ECC on the Fly count

197 Current Pending Sector Count

198 Disconnection beyond repair

199 CRC cyclic redundancy check

200 Write Error Count



*Different manufacturers and different models have different attribute description , the user has no need to know exact meaning ,attribute detection values enough for them.*

## 3、 Threshold

It is specified by manufacturer calculated through a specific formula. If there is a attribute value lower than the threshold, which means HDD become unreliable and data stored is very easy to lose. Composition

and size of reliable attribute values is different for different HDD. It should be noted that, ATA standard only provides some SMART parameters; it does not provide a specific value. "Threshold" value is determined by manufacturers based on products' features. Thus, results tested by manufacturer provided detection software is very different from testing software under Windows (such as AIDA32)

#### **4、 Attribute Value**

Attribute value is the maximum normal value; the general range is from 1 to 253. Typically, the maximum attribute value is 100 (for IBM, Quantum, and Fujitsu) or 253 (for Samsung). Of course, there are some exceptions, for example, some models produced by Western Digital have two different attribute values, and property value is set 200 when initial production, but after then it is changed into 100.

#### **5、 Worst**

Worst value is the largest non-normal value in HDD's running. It is a value calculate for HDD's cumulative running, it is constantly refreshed according to running cycle, and very closed to the threshold. Whether the HDD is normal by S.M.A.R.T analysis is based on the comparison with threshold. The maximum value appear when new HDD start to use, which would continue to decrease with the everyday use or error happen. Consequently, larger attribute values mean better quality and higher reliability; smaller values mean more possibility of failure increases.

#### **6 、 Dates**

Actual values of HDD's detection items, many items are cumulative values.

#### **7、 Status**

It is current statuses of HDD's every attribute after analyzing and comparing above attribute values by S.M.A.R.T, also is important information to judge HDD healthy or not.

There are three statuses: Normal, Alarm and Error----which is closely related with Pre-failure/advisory BIT.

## **11.5 Hard disk problem**

Use Detection Tool provided by the HDD manufacturer to detect the Function of HDD to solve data problem.

We recommend Seagate and Western Digital.



#### **How to detect Seagate HDD**

a) Get into [www.seagate.com](http://www.seagate.com), Click Support & Downloads →choose Sea Tools, download tool, as Diagram

## SeaTools for Windows

SeaTools for Windows tests SATA, USB, 1394, ATA (PATA/IDE) and SCSI drives. It installs onto your system. SeaTools for Windows is completely data safe. If the drive passes SeaTools for Windows, your troubleshooting can move to other areas.



b) Double-click  to install downloaded file, click  installed file to detect the HDD information on PC.

c) Choose the HDD for detection (other manufacturer's hard disk suitable too).



## How to detect WDC HDD

a) Get into [www.wdc.com](http://www.wdc.com), choose WD support / download / SATA&SAS / WD Caviar / GP, download software as 错误!未找到引用源。

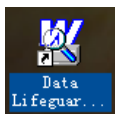

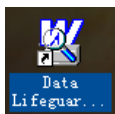
b) Click  to hard disk detection after downloading.

c) Double click hard desk in device list, as 错误!未找到引用源。 :

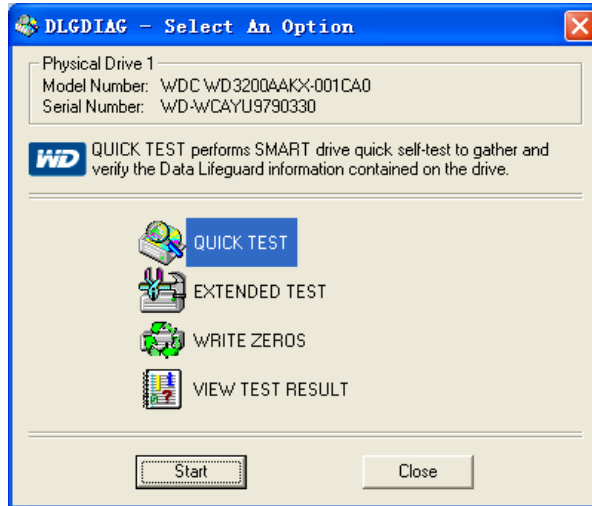

## 11.6 HDD Capacity Calculation

### Reference of HDD Capacity Calculation

The first time install DVR, please check if the HDD has installed.

### The capacity of the HDD

There is no limitation of capacity of single HDD to DVR, please choose the HDD according to the saving time.

### The choose of the Capacity

Computational formula of HDD Capacity:

Whole HDD Capacity = number of the channels × time in need (hour) × spent of HDD Capacity per hour (MB/hour)

Similarly we can have the formula of recording time:

$$\text{Recording time (hour)} = \frac{\text{Total HDD Capacity (MB)}}{\text{Capacity Occupation per Hour (MB/hr)} \times \text{Amount of Channel}}$$



1GB=1000MB, not 1GiB=1024MiB, so HDD capacity shown in Base Configuration under HDD Management less than real marked.

File size per hour (CBR).

Bit Rate	File	Bit Rate	File	Bit Rate	File
96k	42M	320k	140M	896k	393M
128k	56M	384k	168M	1.00M	450M
160k	70M	448k	196M	1.25M	562M
192k	84M	512k	225M	1.50M	675M



224k	98M	640k	281M	1.75M	787M
256k	112M	768k	337M	2.00M	900M

File size is more unpredictable when VBR style, please refer to the real size of recording file.

## 11.7 Terms

### Dual-stream

Dual-stream: one high bit rate stream for the local HD store, QCIF/CIF/2CIF/DCIF/4CIF coding, other low bit rate stream for network transmission, such as QCIF / CIF coding,

### I Frame

I frame: intra frame image, remove redundant information to compress the transmittal data, also called key frames.

### B Frame

B frame: According to time redundant of the source image sequence previously encoded frame and account the source image after the encoded frame to compress transmittal data, also known as bi-directional prediction frame.

### P Frame

P-frame: according to image frame lower than the previous time redundant to compress transmittal data, also called predicted frames.

### Wide Dynamic

Bright parts and dark parts in particular can be seen very clearly at the same time. Wide dynamic range is a ratio between the brightest luminance signal value and the darkest value.

### S. M. A. R. T

SMART (Self Monitoring, Analysis and Reporting Technology): now widely used in hard disk data security technology, monitoring system analysis Motor, circuit, HDD and disk head when HDD working, warn when abnormality, sometimes will automatically slow down and back up data.

### CVBS

Composite Video Broadcast Signal, consists of luminance and color signal from the composite baseband signal.

### BNC

Coaxial cable connector, composite video signals or audio signals, commonly use 75 ohm connectors. BNC welding and should pay attention to weld strength and remove burrs, or the signal wire and shield's contact will lead to a substantial attenuation of signal strength

## 11.8FAQ

### **DVR startup failure or continuously reboot**

Possible reasons:

1. The system has been damaged from a bad DVR update.
2. There is a problem with the DVR main board error, please contact supplier.
3. There is an HDD error. Replace faulty HDD.

### **Remote control does not work**

Possible reasons:

1. Check for batteries in remote control, especially positive and Negative.
2. Check for batteries' power.
3. Check if remote receiver is obscured.
- 3 Check if DVR address corresponds to the remote address.

### **DVR cannot control PTZ**

Possible reasons:

1. RS-485 cable connection error, A, B ports are inversely connected;
2. PTZ decoder, protocol, baud rate, address are incorrect;
3. Parallel connect a 120Ω resistance to resolve signal reflex caused by too many PTZs on the line.
4. The RS-485 on the DVR is defective

### **Blurred screen in preview mode**

Possible reasons:

Please make sure your cameras match your video format selected in the General menu. E.g. camera is NTSC standard but the DVR is PAL standard, the preview would be blurred.

### **Blurred screen in playback mode or failure to playback records**

Possible reasons:

1. Procedure error, reboot the DVR
2. HDD error, test or change out the HDD
3. DVR hardware failure, contact your local supplier

### **Fail to connect DVR through network**

Possible reasons:

- 1、 check the physical network connection is correct.
- 2、 check the DVR network configuration parameters.
- 3、 check whether IP conflicts exist in network.

### **Download records can't be played**

Possible reasons:

- 1 、 Player installation error.
- 2 、 The USB or HDD device has an error.
- 3 、 Do not install graphic software later than DX8.1.

### **Internet Explore Crash**

Possible reasons:

Close IE explore, enter into the tool bar

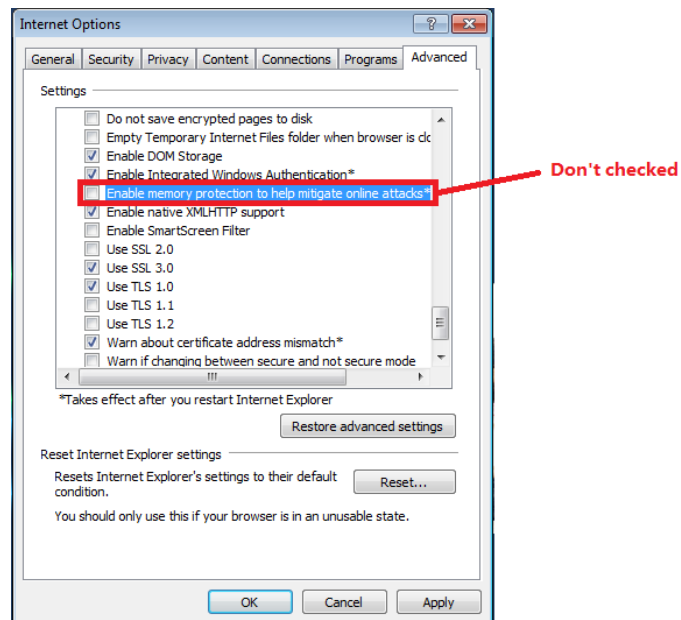

## **FCC Statement**

This equipment has been tested and found to comply with the limits for a Class B digital device, pursuant to part 15 of the FCC rules. These limits are designed to provide reasonable protection against harmful interference in a residential installation. This equipment generates, uses and can radiate radio frequency energy and, if not installed and used in accordance with the instructions, may cause harmful interference to radio communications. However, there is no guarantee that interference will not occur in a particular installation. If this equipment does cause harmful interference to radio or television reception, which can be determined by turning the equipment off and on, the user is encouraged to try to correct the interference by one or more of the following measures:

- Reorient or relocate the receiving antenna.
- Increase the separation between the equipment and receiver.
- Connect the equipment into an outlet on a circuit different from that to which the receiver is connected.
- Consult the dealer or an experienced radio/TV technician for help.

To assure continued compliance, any changes or modifications not expressly approved by the party.

Responsible for compliance could void the user's authority to operate this equipment. (Example- use only shielded interface cables when connecting to computer or peripheral devices).

This equipment complies with Part 15 of the FCC Rules. Operation is subject to the following two conditions:

- (1) This device may not cause harmful interference, and
- (2) This device must accept any interference received, including interference that may cause undesired operation.

## **FCC Radiation Exposure Statement:**

The equipment complies with FCC Radiation exposure limits set forth for uncontrolled environment. This equipment should be installed and operated with minimum distance 20cm between the radiator and your body.