

Installation Manual

PANTHER™ 300M Mobile Radio



NOTICE!

Repairs made to this equipment should be made only by an authorized service technician or facility designated by the supplier. Any repairs, alterations, or substitution of recommended parts made by the user to this equipment not approved by the manufacturer could void the user's authority to operate the equipment in addition to the manufacturer's warranty.

NOTICE!

The software contained in this device is copyrighted by Com-Net Ericsson Critical Radio Systems, Inc. Unpublished rights are reserved under the copyright laws of the United States.

This manual is published by **Com-Net Ericsson Critical Radio Systems, Inc.**, without any warranty. Improvements and changes to this manual necessitated by typographical errors, inaccuracies of current information, or improvements to programs and/or equipment, may be made by **Com-Net Ericsson Critical Radio Systems, Inc.**, at any time and without notice. Such changes will be incorporated into new editions of this manual. No part of this manual may be reproduced or transmitted in any form or by any means, electronic or mechanical, including photocopying and recording, for any purpose, without the express written permission of **Com-Net Ericsson Critical Radio Systems, Inc.**

TABLE OF CONTENTS

SAFETY INFORMATION	4
MAXIMUM PERMISSIBLE EXPOSURE (MPE) LIMITS	5
DETERMINING MPE RADIUS	5
SAFETY TRAINING INFORMATION	6
INTRODUCTION	8
UNPACK AND CHECK THE EQUIPMENT	8
OPTIONS AND ACCESSORIES	9
INSTALLATION	10
STEP 1 - PLAN THE INSTALLATION	10
STEP 2 - LOCATE THE TOOLS REQUIRED	10
STEP 3 – EQUIPMENT PREPARATION	11
Mounting	11
STEP 4 – PROGRAM THE RADIO	16
STEP 5 – INSTALL CABLES	17
Power Cable	17
Connect To Ignition Sense	18
Radio Mounting Procedures	20
STEP 7 – INSTALL OPTIONS AND ACCESSORIES	22
Radio Option Cable	22
External Speaker – 19A149590P11	25
Alarm (Horn) Relay Kit - 19A705499P1	28
Microphone Hanger/Hook Switch Mounting – 344A4678P1	30
Antenna	30
Noise Suppression Kit - Option KMPD1A (19A148539G1)	32

FIGURES

Figure 1 – Typical Connection Diagram	12
Figure 2 – Removing Top Cover	13
Figure 3 – Factory Default Internal Speaker Jumper Setting (Enabled)	14
Figure 4 – Factory Default Settings For Jumper JP600	15
Figure 5 – Removing Plastic Cover	16
Figure 6 – Power Cable RPM 113 7674/10	18
Figure 7 – Mounting Bracket and Mounting Bracket Hardware Kit	20
Figure 8 – Mounting Bracket Installation	21
Figure 9 – Mounting Radio to Bracket	22
Figure 10 - Mounting the External Speaker	25
Figure 11 – External Speaker Option	26
Figure 12 – Internal/External Speaker Relay	27
Figure 13 - External Car Alert	29
Figure 14 - External Alarm Relay	29
Figure 15 – Ignition Sense Option	30

TABLES

Table 1 - PANTHER 300M Mobile Radio Options and Accessories	9
Table 2 – Radio Option Connector P3 Interface Description	23

SAFETY INFORMATION

The operator of any mobile radio should be aware of certain hazards common to the operation of vehicular radio transmissions. **A list of several possible hazards is given:**

1. **Explosive Atmospheres** - Just as it is dangerous to fuel a vehicle with the motor running, similar hazards exist when operating a mobile radio, be sure to turn the radio off while fueling the vehicle. Do not carry containers of fuel in the trunk of the vehicle if the radio is mounted in the trunk.
2. **Interference to Vehicular Electronics Systems** - Electronic fuel injection systems, electronic anti-skid braking systems, electronic cruise control systems, etc., are typical electronic systems that may malfunction due to the lack of protection from radio frequency energy present when transmitting. If the vehicle contains such equipment, consult the dealer and enlist their aid in determining the expected performance of electronic circuits when the radio is transmitting.
3. **Dynamite Blasting Caps** - Dynamite blasting caps may be caused to explode by operating a radio within 500 feet of the blasting caps. Always obey the "**Turn Off Two-Way Radios**" signs posted where dynamite is being used.

When transporting blasting caps in your vehicle:

- a. Carry the blasting caps in a closed metal box with a soft lining.
 - b. Leave the radio OFF whenever the blasting caps are being put into or removed from the vehicle.
4. **Liquefied Petroleum (LP) Gas Powered Vehicles** - Mobile radio installations in vehicles powered by liquefied petroleum gas with the LP gas container in the trunk or other sealed-off space within the interior of the vehicle must conform to the National Fire Protection Association standard (NFPA) 58 requiring:
- a. The space containing the radio equipment shall be isolated by a seal from the space containing the LP gas container and its fittings.
 - b. Outside filling connections shall be used for the LP gas container.
 - c. The LP gas container shall be vented to the outside of the vehicle.

MAXIMUM PERMISSIBLE EXPOSURE (MPE) LIMITS

Do not transmit with this radio and antenna when persons are within the MPE Radius of the antenna, unless such persons (vehicle occupants or bystanders, for example) are shielded from the antenna field by a grounded metallic barrier (such as the user's vehicle rooftop). The MPE Radius is the minimum distance from the antenna axis that ALL persons should maintain in order to avoid RF exposure higher than the allowable MPE level set by the FCC.



FAILURE TO OBSERVE THESE LIMITS MAY ALLOW ALL PERSONS WITHIN THE MPE RADIUS TO EXPERIENCE RF RADIATION ABSORPTION, WHICH EXCEEDS THE FCC MAXIMUM PERMISSIBLE, EXPOSURE (MPE) LIMIT. IT IS THE RESPONSIBILITY OF THE RADIO OPERATOR TO ENSURE THAT THE MAXIMUM PERMISSIBLE EXPOSURE LIMITS ARE OBSERVED AT ALL TIMES DURING RADIO TRANSMISSION. THE RADIO OPERATOR IS TO ENSURE THAT NO BYSTANDERS COME WITHIN THE RADIUS OF THE MAXIMUM PERMISSIBLE EXPOSURE LIMITS SHOWN BELOW.

DETERMINING MPE RADIUS

THE MAXIMUM PERMISSIBLE EXPOSURE RADIUS HAS BEEN ESTIMATED TO BE A RADIUS OF ABOUT 55 INCHES (OR 138 CM) FOR THE VEHICULAR MOUNTED ANTENNA SYSTEMS, AND 77 INCHES (OR 195 CM) FOR BASE STATION MOUNTED ANTENNA SYSTEMS PER OET BULLETIN 65 OF THE FCC. THIS ESTIMATE IS MADE USING THE MAXIMUM CAPABLE POWER OF THE RADIO, ANTENNAS WITH A MAXIMUM GAIN OF 3 dBd (FOR VEHICULAR MOUNTED SYSTEMS) OR 6 dBd (FOR BASE STATION SYSTEMS), AND A MAXIMUM 50% TRANSMIT DUTY CYCLE (DUE TO THE PUSH-TO-TALK STATUS FOR THIS MOBILE).

SAFETY TRAINING INFORMATION



YOUR COM-NET ERICSSON PANTHER 300M MOBILE RADIO GENERATES RF ELECTROMAGNETIC ENERGY DURING TRANSMIT MODE. THIS RADIO IS DESIGNED FOR AND CLASSIFIED AS “OCCUPATIONAL USE ONLY” MEANING IT MUST BE USED ONLY IN THE COURSE OF EMPLOYMENT BY INDIVIDUALS AWARE OF THE HAZARDS AND THE WAYS TO MINIMIZE SUCH HAZARDS. THIS RADIO IS NOT INTENDED FOR USE BY THE “GENERAL POPULATION” IN AN UNCONTROLLED ENVIRONMENT. IT IS THE RESPONSIBILITY OF THE RADIO OPERATOR TO ENSURE THAT THE MAXIMUM PERMISSIBLE EXPOSURE LIMITS DETERMINED IN THE PREVIOUS SECTION ARE OBSERVED AT ALL TIMES DURING TRANSMISSION. THE RADIO OPERATOR IS TO ENSURE THAT NO BYSTANDERS COME WITHIN THE RADIUS OF THE MAXIMUM PERMISSIBLE EXPOSURE LIMITS.

This radio has been examined and complies with the FCC RF exposure limits when persons are beyond the MPE radius of the antenna. In addition, your Com-Net Ericsson radio complies with the following Standards and Guidelines with regard to RF energy and electromagnetic energy levels and evaluation of such levels for exposure to humans:

- FCC OET Bulletin 65 Edition 97-01 Supplement C, Evaluating Compliance with FCC Guidelines for Human Exposure to Radio Frequency Electromagnetic Fields.
- American National Standards Institute (C95.1 – 1992), IEEE Standard for Safety Levels with Respect to Human Exposure to Radio Frequency Electromagnetic Fields, 3 kHz to 300 GHz.
- American National Standards Institute (C95.3 – 1992), IEEE Recommended Practice for the Measurement of Potentially Hazardous Electromagnetic Fields – RF and Microwave.



CAUTION

TO ENSURE THAT YOUR EXPOSURE TO RF ELECTROMAGNETIC ENERGY IS WITHIN THE FCC ALLOWABLE LIMITS FOR OCCUPATIONAL USE, ALWAYS ADHERE TO THE FOLLOWING GUIDELINES:

- DO NOT operate the radio without a proper antenna attached, as this may damage the radio, and may also cause you to exceed FCC RF exposure limits. A proper antenna for installation on a vehicle has a maximum gain of 3 dBd. A proper antenna for installation on a rooftop or tower in a desktop base station setup has a maximum gain of 6 dBd.

INTRODUCTION

The PANTHER™ 300M mobile radio is designed for installation as a front mount radio. This manual provides the mobile installation instructions and includes the instructions to install the external horn or external speaker options.

UNPACK AND CHECK THE EQUIPMENT

Carefully unpack the equipment and verify the items listed below are included in the shipping container. If damage has occurred to the equipment during shipment, file a claim with the carrier immediately. Table 1 on page 9 provides a complete list of the options and accessories available for the PANTHER 300M mobile radio.

PANTHER 300M Radios Are Shipped With The Following:

- PANTHER 300M Mobile RadioKRD 103 154/(1-7)
- Power CableRPM 113 7674/10
- Mounting Bracket
- Mounting Bracket Hardware Kit.....
- Operator's ManualMM101030V1
- Installation ManualMM101031V1

OPTIONS AND ACCESSORIES

The following table lists the options and accessories available for the PANTHER 300M Mobile Radio.

Table 1 - PANTHER 300M Mobile Radio Options and Accessories

DESCRIPTION	PART NUMBER	OPTION NUMBER
Microphone, Standard	KRY 101 1654/1	KAMC7J
Microphone, DTMF	KRY 101 1654/10	KAMC7K
Microphone Hanger	344A4678P1	KAMN1A
External Speaker (4 ohm, 10W)	19A149590P11	KALS1H
Option Cable	RPM 113 7674/1	KACJ7G
External Relay Kit	19A705499P1	KASU1C
Noise Suppression Kit	19A148539G1	KAPD1A
Power Cable	RPM 113 7674/10	KACJ7H
Audio Test Cable	RPM 113 2472/48	
Audio Test Box		TQ0613
Conventional ProGrammer Software or	AE/LZY 213 766/5	TQ3389 R9A or later
ProGrammer Software	AE/LZY 213 766/1	TQ3385 R9A or later
Radio Programming Interface Cable	RPM 113 2472/47	TQ3393
Copy Cat™ Cable, 300M-to-300M	RPM 113 2472/42	TQ3394
Copy Cat™ Cable, 300M-to-300P	RPM 113 2472/41	TQ3395

INSTALLATION

STEP 1 - PLAN THE INSTALLATION

Figure 1 shows an example of a typical connection diagram. Before beginning, plan the radio installation carefully so that it will:

- Be safe for the operator and passengers,
- Be convenient for the operator to use,
- Be neat in appearance,
- Be protected from water damage,
- Be easy to service,
- Be out of the way of auto mechanics,
- Be out of the way of passengers, and
- Allow for good air flow around the unit's cooling fins.

For passenger safety, mount the radio securely so the unit will not break loose in the event of a collision. This is especially important in station wagons, vans and similar type installations where a loose radio could be extremely dangerous to the vehicle occupants.

The procedures in this section provide a guideline for installing the mobile radio. In some applications, it may be necessary to deviate slightly from the recommended procedure and the order in which the equipment is installed.

To assure the feasibility of the cable routes you plan to use, it is suggested that you run the cables before installing the radio. Be sure to leave some slack in each cable so that the radio may be pulled out for servicing with the power applied.

It is recommended the unit be installed by one of the many Com-Net Ericsson Authorized Service Centers located throughout the United States. Personnel at these centers are experienced in installations of this type and can provide a safe, neat, and functional installation.

STEP 2 - LOCATE THE TOOLS REQUIRED

The following tools are required to install the PANTHER 300M Mobile Radio:

- Electric drill for drilling mounting holes

- Drills and circle cutters as follows:
 - No. 31 (1/8-inch) drill
 - 1/2-inch drill or circle cutter
 - 3/4-inch circle cutter, hole saw or socket punch
- Phillips and flat-blade screwdrivers
- No. 10 Torx® driver

Torx is a registered trademark of CAMCAR Division TEXTRON, Inc.

STEP 3 – EQUIPMENT PREPARATION

Mounting

This section describes the radio preparation for installation. In most applications, the following procedures should be completed before the radio is mounted. Depending upon the mounting location, these procedures could become very difficult after the radio is mounted. The preparation list includes:

- Configuring the Internal Speaker Jumper
- Configuring the Ignition Sense Line Jumper
- Connecting the Option Cable to the Radio

Read through the procedures provided in this section. If you are satisfied with the default factory jumper settings and your installation does not require an option cable, skip this section and go to **STEP 4 – PROGRAM THE RADIO** on page 16.

Removing the Top Cover and Shield

The top cover and shield must be removed to change the Internal Speaker jumper (JP701) or the ignition sense line jumper (JP600), to connect the option cable to the radio.

1. The top cover is secured with three screws from the bottom of the radio. Using a No. 10 Torx® driver, loosen the three screws Ⓐ on the top of the radio as shown in Figure 2.
2. Remove the two control knobs from the front of the radio.
3. Pry the cover loose from the two tabs on the bottom of the radio.

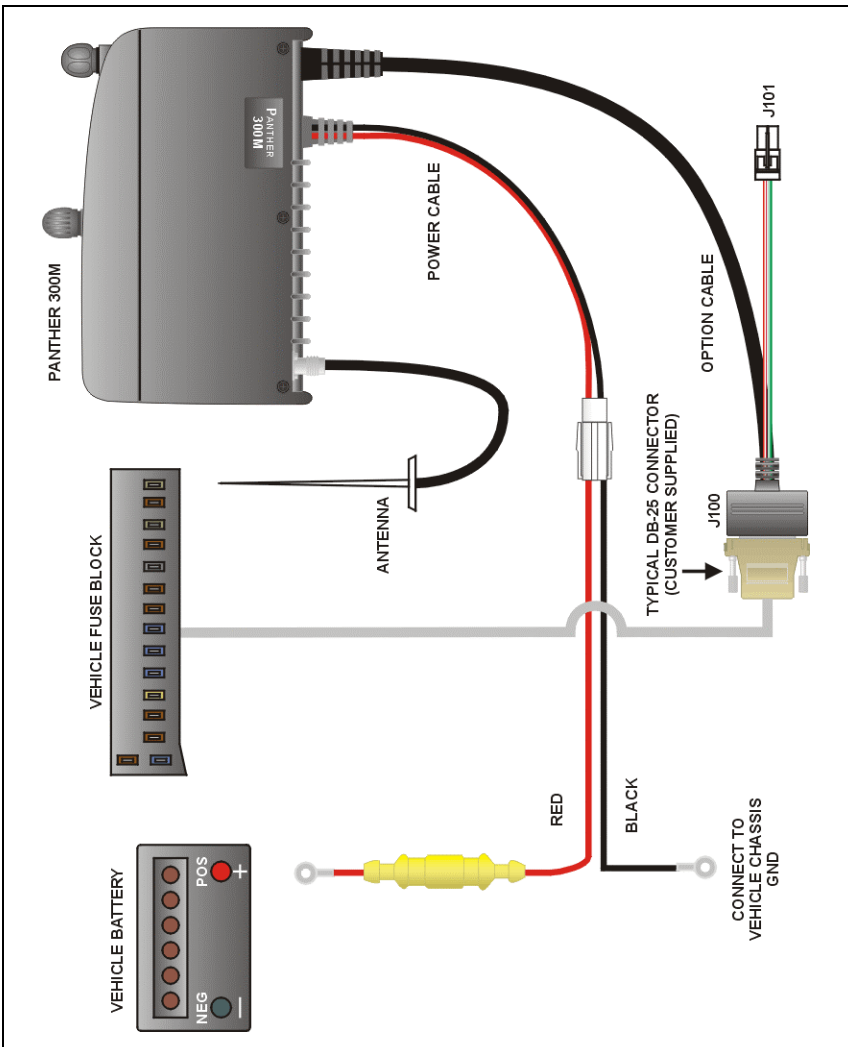

Figure 1 – Typical Connection Diagram

4. Remove the top cover by lifting the back and sliding it forward away from the chassis.



Figure 2 – Removing Top Cover

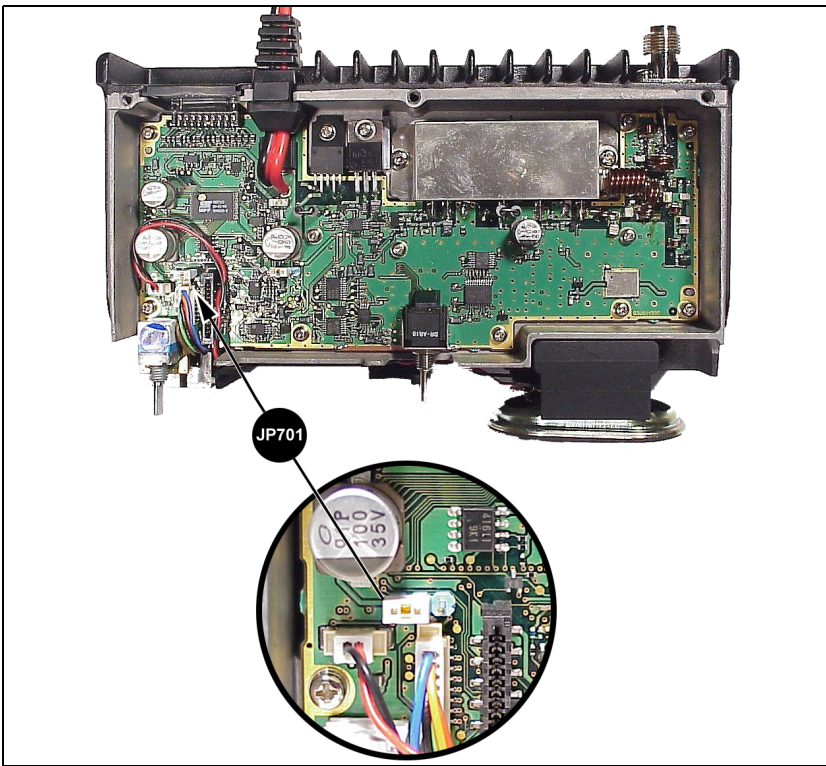

Figure 3 – Factory Default Internal Speaker Jumper Setting (Enabled)

Configure the Internal Radio Speaker Jumper (JP701)

The PANTHER 300M radio is shipped from the factory with the internal radio speaker jumper (JP701) set to 1-2 as shown in Figure 3. This setting enables the internal radio speaker. Set the jumper to 2-3 if 1) only the External Speaker is to be enabled or 2) the Internal/External Speaker option is to be enabled.

Configure Ignition Sense Jumper (JP600)

The Ignition Sense line is used to enable or disable transmit or car horn alert option through the vehicle ignition switch. If the Ignition Sense option is desired, Ignition Sense jumper JP600 must be set to 2-3. The PANTHER 300M radio is shipped from the factory with the Ignition Sense jumper (JP600) set to 1-2 as shown in Figure 4. This default setting disables the Ignition Sense option. If your installation will not take advantage of the Ignition Sense line, skip this section and proceed to the next section.