

Connect Option Cable

This section applies to installations that require an option cable. The option cable (RPM 113 7674/1) is required if you are installing:

- External Speaker
- Internal/External Speaker Option
- Car Horn Alert
- Ignition Sense
- External Modulation
- External Demodulation

To connect the option cable to the radio:

1. Remove the two Phillips screws holding the plastic cover in place, from the back of the radio, see Figure 5.

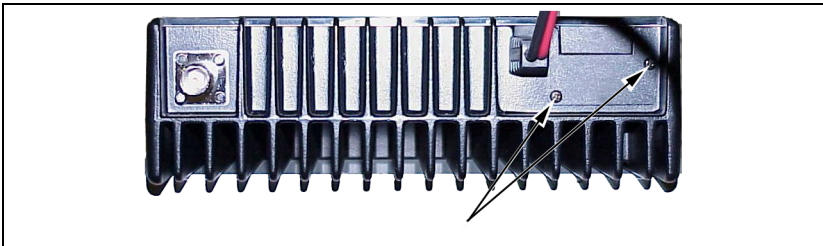

Figure 5 – Removing Plastic Cover

2. Insert the option cable through the hole left by removing the plastic cover. This will allow the connector to fit through the hole in the back of the radio.
3. Plug the option cable connector into J3 on the radio circuit board.
4. Finally, attach cable with the two Phillips screws.

STEP 4 – PROGRAM THE RADIO

All radios must be programmed with a radio personality. There are many parameters in the PANTHER 300M mobile radio that need to be setup and defined for the radio to operate appropriately for each application. Conventional ProGrammer (TQ-3389 R9A or later) or ProGrammer (TQ-3385 R9A or later) is the software used to create

the personality for the PANTHER 300M radio. The radio personality is a computer file that defines all the operating parameters for the radio. For more information on programming the PANTHER 300M radio, see the On-Line Help provided with Conventional ProGrammer (TQ-3389 R9A or later) or ProGrammer (TQ-3385 R9A or later). Typically, the radio is programmed before it is installed in a vehicle.

STEP 5 – INSTALL CABLES

The PANTHER 300M Mobile Radio is installed as a front mount radio. The location of the mount, the application, and the options to be installed should be considered when planning the cable runs. The cable diagram in Figure 1 should be referenced throughout the installation process.

Power Cable

The power cable RPM 113 7674/10 consists of a two-wire cable, see Figure 6. The red fused lead supplies power to the radio directly from the vehicle battery. Ignition Sense lead, through the separate option cable, is used by the radio electronics to determine when the ignition switch is turned on. The black lead is the radio ground connection.

To install the power cable:

1. Remove the fuse from the power cable.
2. When the power cable is wired directly to the vehicle's battery, it is necessary to route the red power lead through the vehicle's firewall. If an existing hole is not conveniently located in the firewall, drill a 1/2-inch hole in the firewall for the cable run and insert a rubber grommet. This grommet is required to prevent lead chaffing. Additional grommets may be required if the leads must pass through shields or guards in the engine compartment.

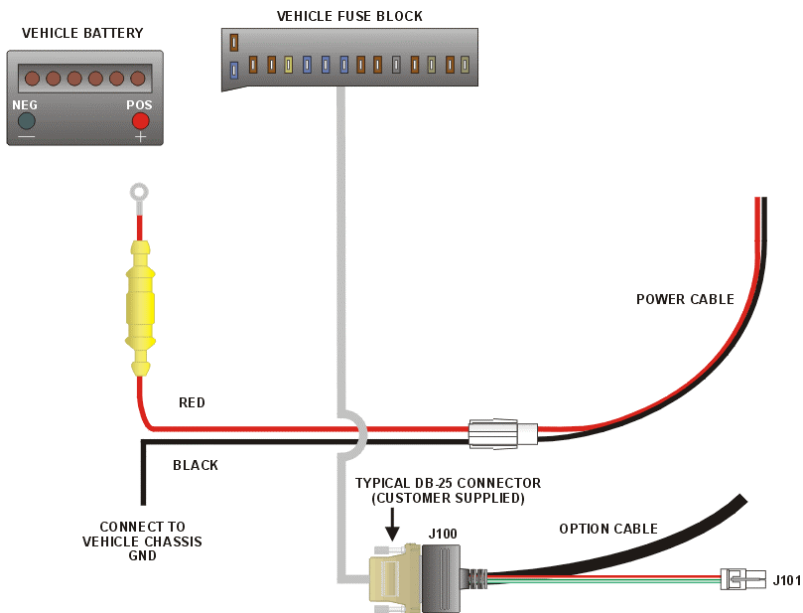

Figure 6 – Power Cable RPM 113 7674/10

Route the lead away from high heat sources in the engine compartment that may cause lead damage and introduce a fire hazard. In addition, the lead ***should not*** be routed near electrical noise sources such as electronic ignition modules or cruise control modules.

3. Secure the cable at several locations within the engine compartment to prevent possible damage to the cable.
4. Connect the BLACK lead to the vehicle chassis. Connect the lead as close to the radio as possible. DO NOT connect the BLACK lead to the “NEG” or “-“ battery post. Connect the RED lead to the positive (“POS” or “+”) battery post. See Figure 6.



The power source must have a minimum current supply capability of 13 amps.

Connect To Ignition Sense

The ignition sense line is used to enable or disable transmit or the Car Horn Alert option through the vehicle ignition switch. For a

detailed description on how to configure the Ignition Sense line, see the section **Configure Ignition Sense Jumper** on page 14. Regardless of how the ignition sense line is configured, the option cable must be wired as described below for the feature to work.

Connect Pin 13 of the option cable to an ignition “ON” sense point (preferably an “Accessory” point in the vehicle fuse panel) that is switched on when the vehicle ignition switch is in the ACCESSORY and RUN positions. This lead should be connected so the vehicle fuse protection is used. See Figure 6.



The DB-25 male connector that connects to the option cable is user-supplied.

CAUTION

The “Accessory” point should drop to ZERO volts when cranking the engine and return to +12 volts after the engine is started. If a point is chosen that drops to a voltage between zero and +12 volts, the radio may execute a power-up cycle several times during start up. It is recommended that the terminal be measured with a voltmeter to be sure it shuts off (goes to zero volts) during the cranking of the engine.

Certain problems may be encountered when accessory equipment is connected to the ignition or accessory lines of the vehicle, where these lines may have large filter capacitors and a leakage path present. If the radio does not turn off within a reasonable amount of time after the ignition is turned off, first try a different accessory or ignition A+ pick up point in the vehicle. Many vehicles have more than one circuit that is switched by the ignition switch, and one may be available that does not have large filter capacitors or a leakage path present.

If a different pickup point cannot be found, then add a 470-ohm, 1-watt resistor from the ignition A+ pick point to ground. This will discharge the capacitor(s) or reduce the leakage voltage to a low value. Current drain through this resistor will be minimal (less than 0.03A) when the ignition is switched on.



Figure 7 – Mounting Bracket and Mounting Bracket Hardware Kit

Radio Mounting Procedures

The following procedures are used to mount the radio.

1. Using the bracket as a template, mark and drill the mounting holes using a No. 31 (1/8) drill bit. Be sure to leave enough room at the rear of the radio unit for the cable connections and airflow.

CAUTION

Be careful to avoid damaging some vital part (fuel tank, transmission housing, etc.) of the vehicle when drilling mounting holes. Always check to see how far the mounting screws will extend below the mounting surface before installing.

If pilot holes must be drilled, remove all metal shavings from drilling holes before installing screws.

2. Mount the bracket using the four 3/4” Phillips sheet metal screws and spacers provided in the mounting bracket hardware kit. (Refer to Figure 8.)

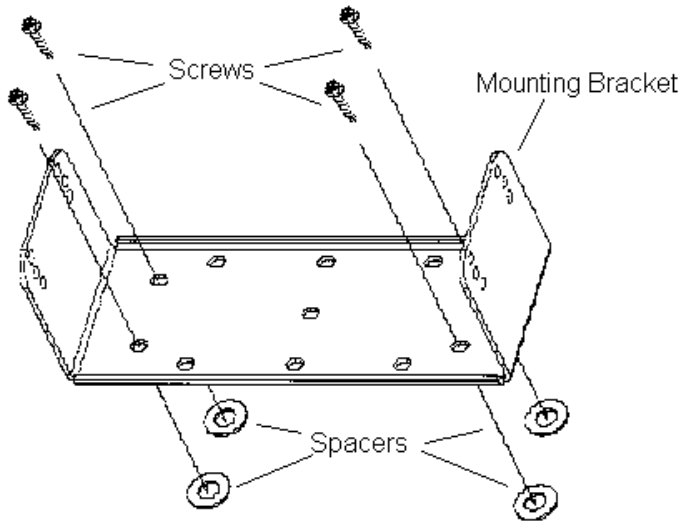

Figure 8 –Mounting Bracket Installation

3. Place the radio into the mounting bracket and secure with the four 3/8" Phillip's screws supplied. The radio can be fastened in any of three different positions: parallel to the mounting surface or tilted slightly from the parallel position. (Refer to Figure 9.)
4. Connect antenna coaxial cable to antenna connector (TNC).
5. Insert power cable into power connector running from rear of radio unit and push until the connectors snap together.
6. Recheck all connections and then reinsert fuse into the fuse assembly on the power cable.

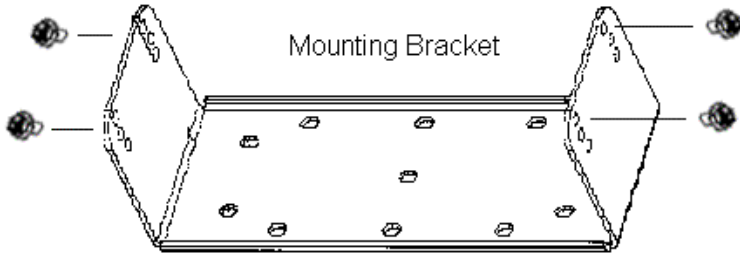

Figure 9 – Mounting Radio to Bracket

STEP 7 – INSTALL OPTIONS AND ACCESSORIES

Radio Option Cable

The radio option cable (RPM 113 7674/1) is required if you are installing:

- External Speaker
- Internal/External Speaker Option
- Car Horn Alert
- Ignition Sense
- External Modulation
- External Demodulation

The section **STEP 3 – EQUIPMENT PREPARATION**, on page 11, describes how to connect the option cable to the radio. The other end of the option cable consists of a standard female DB-25 connector, which is used to connect to the optional accessories listed above. Table 2 provides a description for each input and output on the radio option connector J603.

Table 2 – Radio Option Connector P3 Interface Description

DB-25 Pin No (J100)	Pin No (P3)	I/O	Description
2	1	---	Ground: <input type="checkbox"/> Audio Ground
5	2	I	Internal Speaker Input #1: <input type="checkbox"/> 5W across Internal Speaker
6	3	O	Audio Amp Output #1: <input type="checkbox"/> $V_o \approx 6.6$ VDC
18	4	O	Audio Amp Output #2 to Internal or External Speaker <input type="checkbox"/> $V_o \approx 6.6$ VDC; 10W maximum across External Speaker
19	5	I	External Mic Input: <input type="checkbox"/> 300-3000 Hz <input type="checkbox"/> Input level @ 1kHz for 60% of RSD: 82 ± 28 mV _{RMS} (if external audio source has $R_o=600\Omega$) <input type="checkbox"/> Input level @ 1kHz for 60% of RSD: 41 ± 14 m V _{RMS} (if external audio source has $R_o<1\Omega$)
7	6	I	External Mod Input: <input type="checkbox"/> 5-10,000 Hz (3 db BW) <input type="checkbox"/> Modulation-Sensitivity: 4.2 kHz/Vrms \pm 3dB
20	7	O	Switched DC Output: <input type="checkbox"/> $I_{cc}=500$ mA Max
8	8	I	Push To Talk: <input type="checkbox"/> TX ON: Low <input type="checkbox"/> TX OFF: Open
21	9	I	Mic Hookswitch: <input type="checkbox"/> "Disable" or "Enable" is selected by PC Programmer <input type="checkbox"/> Hookswitch ON: Low <input type="checkbox"/> Hookswitch OFF: Open
9	10	O	Rx Discriminator Detect Audio: <input type="checkbox"/> 20-4,000 Hz (3 dB Bandwidth) <input type="checkbox"/> 75 m V _{RMS} \pm 3 dB into a 10K ohm load
22	11	---	Ground
10	12	I	Internal Mic Mute: <input type="checkbox"/> Mute ON: Low <input type="checkbox"/> Mute OFF: Open
23	13	O	Radio UnSquelch: <input type="checkbox"/> Squelch Open: Low <input type="checkbox"/> Squelch Close: High <input type="checkbox"/> RL = 4.7 kohms
11	14		Spare

Table 2 - Radio Option Connector P3 Interface Description Cont'd

DB-25 Pin No (J100)	Pin No (P3)	I/O	Description						
24	15	O	<p>(1) HORN CONTROL At Signaling Mode</p> <table border="0" data-bbox="386 252 791 323"> <tr> <td><u>Display In Menu</u></td> <td><u>Action</u></td> </tr> <tr> <td>On</td> <td>Enable</td> </tr> <tr> <td>Off</td> <td>Disable</td> </tr> </table> <ul style="list-style-type: none"> <input type="checkbox"/> When select "ON"(enable) and a correct T99 Individual Call is received, the output of pin 15 is "low." <input type="checkbox"/> Horn Alarm ON : Low <input type="checkbox"/> Horn Alarm OFF: Open <p>(2) SPEAKER SELECT INTERNAL/EXTERNAL</p> <ul style="list-style-type: none"> <input type="checkbox"/> Enabling or disabling of the Internal/External Speaker option is done by proper setting of an internal jumper in the mobile radio. <input type="checkbox"/> Internal: Low <input type="checkbox"/> External: Open <input type="checkbox"/> For relay control lo_max = 150mA <input type="checkbox"/> ***"HORN CONTROL" or "SPEAKER SELECT" is selected by PC ProGrammer. <p>Note: Internal and external speaker do not operate simultaneously.</p>	<u>Display In Menu</u>	<u>Action</u>	On	Enable	Off	Disable
<u>Display In Menu</u>	<u>Action</u>								
On	Enable								
Off	Disable								
12	16	I	<p>Data Communication Input (Test Mode)</p> <ul style="list-style-type: none"> <input type="checkbox"/> TTL Level 						
25	17	O	<p>Data Communication Output (Test Mode)</p> <ul style="list-style-type: none"> <input type="checkbox"/> TTL Level 						
13	18	I	<p>Ignition Sense</p> <ul style="list-style-type: none"> <input type="checkbox"/> 13.6VDC <input type="checkbox"/> lo_max = 100 mA 						

NOTE

Internal Mic Mute (DB25-10) must be grounded when applying audio to external Mic Input (DB25-19). External Mic Input (DB25-19) has the same audio characteristics as the Front Panel Mic Jack. External Mod Input (DB25-7) has no pre-emphasis or modulation limiting.

External Speaker – 19A149590P11

The external speaker kit includes a 4-ohm, 10 Watt rated speaker and a radio option cable. To connect an external speaker, the radio option cable (RPM 113 7674/1) must be installed and connected to the radio.

1. Mount the speaker so it is directed at the operator but does not interfere with the operator's vision. It also should not present a hazard in the event of an accident. The speaker may be mounted on the lower edge of the instrument panel, the firewall, or above the windshield in some trucks.
2. Use the mounting bracket as a template for locating the mounting holes, and mount the speaker as shown in Figure 10.
3. Refer to Figure 9 for instructions on connecting the External Speaker option and Figure 10 for instructions on connecting the Internal/External Speaker option.

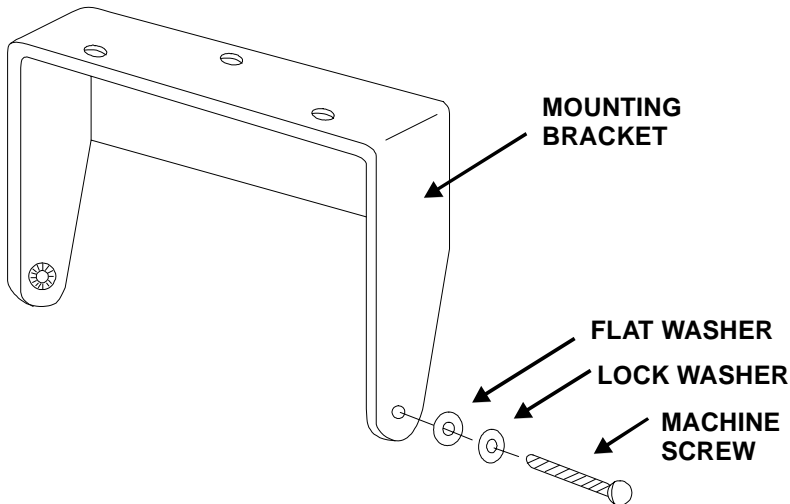
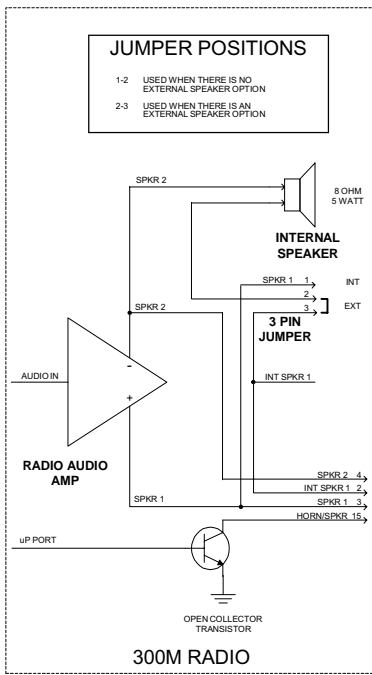

Figure 10 - Mounting the External Speaker



PANTHER 300M EXTERNAL SPEAKER OPTION

WHEN THE EXTERNAL SPEAKER OPTION IS APPLIED, AUDIO FROM THE SPEAKER AMP LEAVES THE RADIO ON OPTION CONNECTOR PINS 3 AND 4 AND GOES TO J101. THE EXTERNAL SPEAKER'S CABLE IS CONNECTED TO J101.

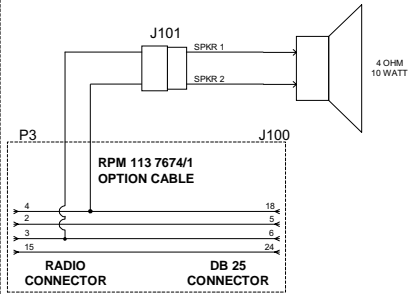

Figure 11 – External Speaker Option

PANTHER 300M INTERNAL/EXTERNAL SPEAKER OPTION

(THIS SCHEMATIC ALSO APPLIES TO PUBLIC ADDRESS)

WHEN THE INTERNAL/EXTERNAL SPEAKER OR PUBLIC ADDRESS OPTIONS ARE APPLIED, AUDIO FROM THE SPEAKER AMP LEAVES THE RADIO ON OPTION CONNECTOR PIN 3 AND GOES TO THE COMMON SIDE OF AN SPDT RELAY.

WHEN INTERNAL SPEAKER IS SELECTED, THE RELAY FLOATS. THE NORMALLY CLOSED RELAY CONTACT APPLIES AUDIO BACK INTO THE RADIO TO THE INTERNAL SPEAKER ON OPTION CONNECTOR PIN 2. (IT IS ASSUMED THE INTERNAL 3-PIN JUMPER IS ON PINS 2 & 3.)

WHEN THE EXTERNAL SPEAKER IS SELECTED, THE RELAY IS ENGAGED. AUDIO IS APPLIED TO THE NORMALLY OPEN CONTACT THAT THEN CONNECTS TO THE EXTERNAL SPEAKER.

ONLY THE SPKR_1 SIDE OF THE AUDIO AMP'S OUTPUT IS SWITCHED. THE SPKR_2 SIDE OF THE AUDIO AMP IS CONNECTED TO BOTH SPEAKERS.

OUR SPEAKER RELAY KIT INCLUDES THE 19A1492/98P1 RELAY, WIRE, AND A FUSE. THE CUSTOMER IS RESPONSIBLE FOR INSTALLING AND PROVIDING POWER TO THE RELAY.

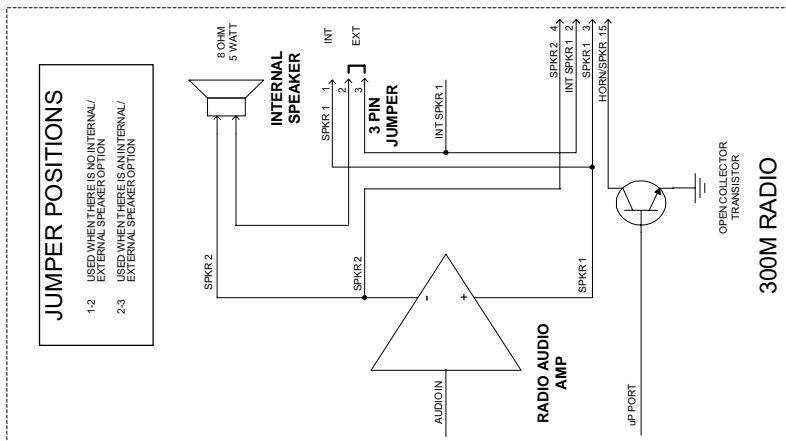

Figure 12 – Internal/External Speaker Relay

Alarm (Horn) Relay Kit - 19A705499P1

To connect the alarm relay kit, the radio option cable (RPM 113 7674/1) must be installed and connected to the radio. The alarm relay kit option consists of the following items:

- Relay (19A149299P1)
- Fuse holder
- Fuse, 1 amp, 250 volt
- 4 feet red wire, AWG #18 with Ring Tongue Terminal for 3/ 8 stud
- 6 feet black wire, AWG #18 with Molex #39- 00- 0060 terminal
- (5) Insulated 1/ 4 inch spade tab receptacles
- Ring Tongue Terminal for 3/ 8 inch stud
- #8 x 3/ 4 long Type A sheet metal screw
- Nut Plate for #8 screw

To install the Alarm (Horn) Relay Kit

1. Fasten the relay in the desired location, close to the voltage source, using one #8 x 3/ 4 inch self- tapping screw.
2. Crimp an insulated 1/ 4 inch spade tab receptacle to one end of the #18 red wire.
3. Connect the receptacle to relay lug #86. Cut the red lead so the fuse assembly is close to the voltage source. Install the fuse holder. Attach the other end of the fuse lead to the voltage source with appropriate hardware. See Figure 14.
4. From the radio option cable, take the green/white wire and crimp an insulated 1/ 4 inch spade tab receptacle. Connect the receptacle to relay lug #85.
5. Connect the horn or light circuit to lugs #30 and #87 (not 87a) using the insulated 1/ 4 inch spade tab receptacles.



The relay contact make/ break current and voltage rating is 30 amps at 16 volts.

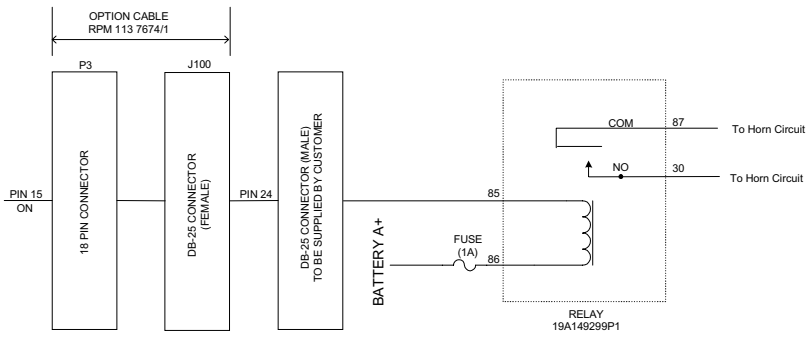

Figure 13 - External Car Alert

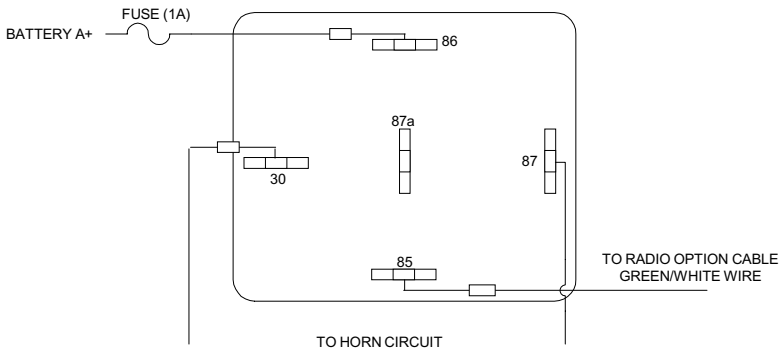

Figure 14 - External Alarm Relay

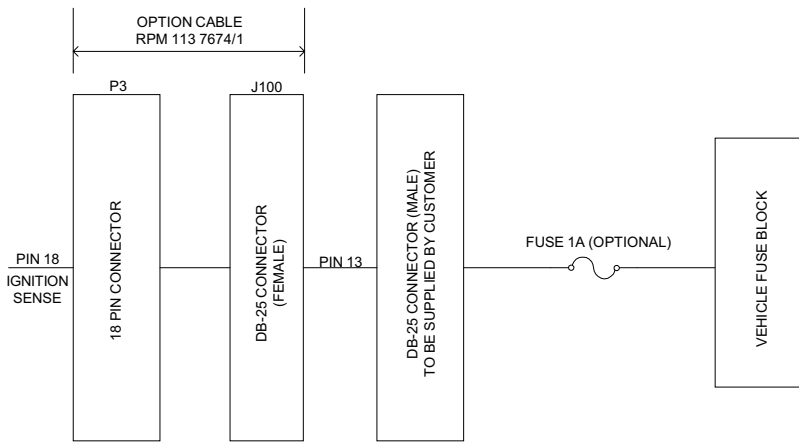

Figure 15 – Ignition Sense Option

Microphone Hanger/Hook Switch Mounting – 344A4678P1

The microphone hanger or Hook Switch should be mounted in a location convenient to the operator where it will not interfere with the safe operation of the vehicle or be a hazard to the vehicle passengers. The hanger or hook switch is designed to mount with the open end of the mounting button slot pointed upward.

1. Use the hanger or Hook Switch as a template to mark and drill the mounting holes. Mount the hanger or hook switch with the self-tapping screws provided.
2. Connect microphone connector to connector on control unit and secure with captive screw.



Do not torque microphone connector screw greater than 2 in-lb. Alternatively, finger tight plus 1/4 turn is acceptable.

Antenna

Installation instructions for the antenna are packaged with the antenna. The antenna must be installed in accordance with good engineering practice for optimum results.

Typical Mobile Antenna Installation

A permanent mount-type antenna should be located in the center of the roof or center of rear deck. *Important Note: Rear deck mounting of an antenna is only applicable when the installation provides at least 55 inches between the antenna and occupants of the vehicle.*

The Maximum Permissible Exposure limit is a radius of 55 inches (or 138 cm) for roof or rear deck installations per OET Bulletin 65 of the FCC. This estimate is made using the maximum capable transmit power of the radio, an antenna with a maximum gain of 3 dBd, and a maximum 50% transmit duty cycle (due to the push-to-talk status of this mobile).



SEE “MAXIMUM PERMISSIBLE EXPOSURE LIMITS” AND “SAFETY TRAINING INFORMATION” SECTIONS AT THE BEGINNING OF THIS MANUAL FOR FURTHER INFORMATION REGARDING MAXIMUM PERMISSIBLE EXPOSURE (MPE) LIMITS OF RF RADIATION ABSORPTION SET BY THE FCC.

Try to route the cable away from locations where it will be exposed to heat, sharp edges or mechanical damage, and where it will be out of the way of the driver, passengers or vehicles mechanics. Wherever possible, existing holes in the trunk wall, and the channels above or beneath doors and window columns should be utilized.

Avoid routing the antenna cable near any electronic modules or along side any vehicle wiring.

Connect the antenna cable to the TNC on the radio, being careful not to twist the cable.

Typical Desktop Base Station Antenna Installation

For desktop base station configurations, a typical building roof top/tower installation may be used.

The Maximum Permissible Exposure limit is a radius of 77 inches (or 195 cm) for typical desktop base station configurations per OET Bulletin 65 of the FCC. This estimate is made using the maximum capable transmit power of the radio, an antenna with a maximum gain of 6 dBd, and a maximum 50% transmit duty cycle (due to the push-to-talk status of this mobile).

Noise Suppression Kit - Option KMPD1A (19A148539G1)

Refer to the noise suppression kit option installation manual that is included with this option.

NOTES

NOTES

NOTES

Com-Net Ericsson Critical Radio Systems, Inc.
P.O. Box 2000
Lynchburg, Virginia 24501
1-800-528-7711 (Outside USA, 804-592-7711)

Printed in U.S.A.