

# Installation Manual

MM102342 V1 P5A

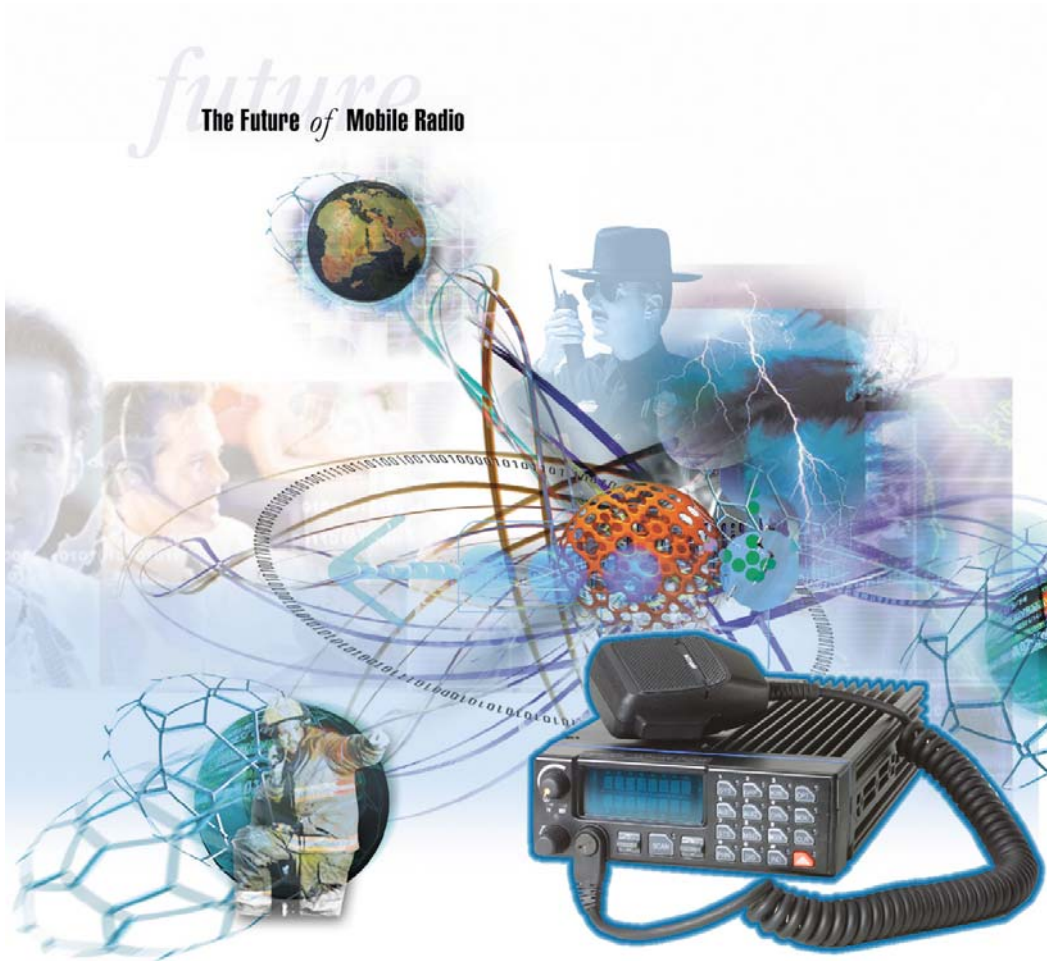

*future*  
The Future of Mobile Radio

## M7100<sup>IP</sup> Series Mobile Radio

**tyco**  
Electronics

**M/A-COM**

### **SUPPLEMENTARY INFORMATION:**

At this time, the M7100<sup>IP</sup> mobile radio may not be operated while in a desktop station in the European Community since it does not meet immunity requirements when operated in this mode. The M7100<sup>IP</sup> mobile radio can be used in both trunked and conventional applications.

### **ACKNOWLEDGEMENTS**

This device is made under license under one or more of the following US patents: 4,590,473; 4,636,791; 5,148,482; 5,185,796; 5,271,017; 5,377,229.

The voice coding technology embodied in this product is protected by intellectual property rights including patent rights, copyrights, and trade secrets of Digital Voice Systems, Inc. The user of this technology is explicitly prohibited from attempting to decompile, reverse engineer, or disassemble the Object Code, or in any other way convert the Object Code into human-readable form.

EDACS is a registered trademark and ProGrammer, SCAT, Failsoft, ProSound, ProScan, Aegis, ProFile, ProVoice, and G-STAR are trademarks of M/A-COM, Inc.

Torx is a registered trademark of CAMCAR Division TEXTRON, Inc.

POZIDRIV is a registered trademark of Phillips International Company.

### **NOTICE!**

This manual covers M/A-COM, Inc. products manufactured and sold by M/A-COM, Inc.

### **NOTICE!**

Repairs to this equipment should be made only by an authorized service technician or facility designated by the supplier. Any repairs, alterations or substitution of recommended parts made by the user to this equipment not approved by the manufacturer could void the user's authority to operate the equipment in addition to the manufacturer's warranty.

This manual is published by **M/A-COM, Inc.**, without any warranty. Improvements and changes to this manual necessitated by typographical errors, inaccuracies of current information, or improvements to programs and/or equipment, may be made by **M/A-COM, Inc.**, at any time and without notice. Such changes will be incorporated into new editions of this manual. No part of this manual may be reproduced or transmitted in any form or by any means, electronic or mechanical, including photocopying and recording, for any purpose, without the express written permission of **M/A-COM, Inc.**

## TABLE OF CONTENTS

	<i>Page</i>
<b>TABLE OF CONTENTS</b> .....	<b>3</b>
<b>SAFETY INFORMATION</b> .....	<b>4</b>
<b>RF ENERGY EXPOSURE INFORMATION</b> .....	<b>5</b>
RF ENERGY AWARENESS, CONTROL, AND OPERATION .....	5
COMPLIANCE WITH RF EXPOSURE STANDARDS.....	6
<b>OPERATION SAFETY RECOMMENDATIONS</b> .....	<b>8</b>
TRANSMITTER HAZARDS.....	8
SAFE DRIVING RECOMMENDATIONS.....	9
<b>OPERATING RULES AND REGULATIONS</b> .....	<b>10</b>
OPERATING TIPS .....	11
<b>INTRODUCTION</b> .....	<b>12</b>
<b>UNPACKING AND CHECKING EQUIPMENT</b> .....	<b>13</b>
<b>PLANNING THE INSTALLATION</b> .....	<b>17</b>
<b>EQUIPMENT REQUIRED</b> .....	<b>19</b>
<b>INSTALLATION</b> .....	<b>20</b>
RUNNING CABLES .....	20
CONTROL UNIT MOUNTING.....	28
PIGTAIL BRACKET .....	28
SPEAKER .....	31
MICROPHONE HANGER AND/OR HOOKSWITCH MOUNTING ..	32
SIREN AND LIGHT .....	32
RADIO MOUNTING AND FINAL HOOK-UP .....	33
<b>DUAL CONTROL UNITS</b> .....	<b>37</b>
PRE-INSTALLATION PROGRAMMING PROCEDURE WITH PROGRAMMER - FRONT MOUNT .....	38
PRE-INSTALLATION PROGRAMMING PROCEDURE WITH PROGRAMMER - REMOTE MOUNT .....	40
INSTALLATION INSTRUCTIONS FOR FRONT MOUNT DUAL CONTROL UNITS .....	42
INSTALLATION INSTRUCTIONS FOR REMOTE MOUNT DUAL CONTROL UNITS .....	45
FIELD PROGRAMMING WITH PROGRAMMER – DUAL CONTROL UNITS .....	48
<b>DUAL RADIO UNITS</b> .....	<b>54</b>
PRE-INSTALLATION PROGRAMMING PROCEDURE WITH PROGRAMMER – DUAL RADIO UNITS.....	54
PROGRAMMING WITH PC PROGRAMMER – DUAL RADIO UNITS.....	58
ANTENNA .....	63
<b>WARRANTY</b> .....	<b>64</b>

## SAFETY INFORMATION

The operator of any mobile radio should be aware of certain hazards common to the operation of vehicular radio transmissions. **A list of several possible hazards is given:**

1. **Explosive Atmospheres** - Just as it is dangerous to fuel a vehicle with the motor running, similar hazards exist when operating a mobile radio, be sure to turn the radio off while fueling the vehicle. Do not carry containers of fuel in the trunk of the vehicle if the radio is mounted in the trunk.
2. **Interference to Vehicular Electronics Systems** - Electronic fuel injection systems, electronic anti-skid braking systems, electronic cruise control systems, etc., are typical electronic systems that may malfunction due to the lack of protection from radio frequency energy present when transmitting. If the vehicle contains such equipment, consult the dealer and enlist their aid in determining the expected performance of electronic circuits when the radio is transmitting.
3. **Dynamite Blasting Caps** - Dynamite blasting caps may be caused to explode by operating a radio within 500 feet of the blasting caps. Always obey the "**Turn Off Two-Way Radios**" signs posted where dynamite is being used.

When transporting blasting caps in your vehicle:

- A. Carry the blasting caps in a closed metal box with a soft lining.
  - B. Leave the radio OFF whenever the blasting caps are being put into or removed from the vehicle.
4. **Liquefied Petroleum (LP) Gas Powered Vehicles** - Mobile radio installations in vehicles powered by liquefied petroleum gas with the LP gas container in the trunk or other sealed-off space within the interior of the vehicle must conform to the National Fire Protection Association standard (NFPA) 58 requiring:
    - A. The space containing the radio equipment shall be isolated by a seal from the space containing the LP gas container and its fittings.
    - B. Outside filling connections shall be used for the LP gas container.
    - C. The LP gas container shall be vented to the outside of the vehicle.

## **RF ENERGY EXPOSURE INFORMATION**

### **RF ENERGY EXPOSURE AWARENESS, CONTROL INFORMATION, AND OPERATION INSTRUCTIONS FOR FCC OCCUPATIONAL USE REQUIREMENTS**

**BEFORE USING YOUR MOBILE TWO-WAY RADIO, READ THIS IMPORTANT RF ENERGY AWARENESS AND CONTROL INFORMATION AND OPERATIONAL INSTRUCTIONS TO ENSURE COMPLIANCE WITH THE FCC'S RF EXPOSURE GUIDELINES.**

**NOTICE:** This radio is intended for use in occupational/controlled conditions, where users have full knowledge of their exposure and can exercise control over their exposure to meet FCC limits. This radio device is NOT authorized for general population, consumer, or any other use.

This two-way radio uses electromagnetic energy in the radio frequency (RF) spectrum to provide communications between two or more users over a distance. It uses RF energy or radio waves to send and receive calls. RF energy is one form of electromagnetic energy. Other forms include, but are not limited to, electric power, sunlight, and x-rays. RF energy, however, should not be confused with these other forms of electromagnetic energy, which, when used improperly, can cause biological damage. Very high levels of x-rays, for example, can damage tissues and genetic material.

Experts in science, engineering, medicine, health, and industry work with organizations to develop standards for exposure to RF energy. These standards provide recommended levels of RF exposure for both workers and the general public. These recommended RF exposure levels include substantial margins of protection. All two-way radios marketed in North America are designed, manufactured, and tested to ensure they meet government established RF exposure levels. In addition, manufacturers also recommend specific operating instructions to users of two-way radios. These instructions are important because they inform users about RF energy exposure and provide simple procedures on how to control it. Please refer to the following websites for more information on what RF energy exposure is and how to control your exposure to assure compliance with established RF exposure limits.

<http://www.fcc.gov/oet/rfsafety/rf-faqs.html>

<http://www.osha.gov/SLTC/radiofrequencyradiation/index.html>

#### **Federal Communications Commission Regulations**

Your M/A-COM, Inc. M7100<sup>IP</sup> mobile two-way radio is designed and tested

to comply with the FCC RF energy exposure limits for mobile two-way radios before it can be marketed in the United States. When two-way radios are used as a consequence of employment, the FCC requires users to be fully aware of and able to control their exposure to meet occupational requirements. Exposure awareness can be facilitated by the use of a label directing users to specific user awareness information. Your M/A-COM, Inc. M7100<sup>IP</sup> two-way radio has an RF exposure product label. Also, your M7100<sup>IP</sup> Installation and Operator's Manuals include information and operating instructions required to control your RF exposure and to satisfy compliance requirements.

**COMPLIANCE WITH RF EXPOSURE STANDARDS**

Your M/A-COM, Inc. M7100<sup>IP</sup> mobile two-way radio is designed and tested to comply with a number of national and international standards and guidelines (listed below) regarding human exposure to RF electromagnetic energy. This radio complies with the IEEE and ICNIRP exposure limits for occupational/controlled RF exposure environment at duty factors of up to 50% talk-50% listen and is authorized by the FCC for occupational use. In terms of measuring RF energy for compliance with the FCC exposure guidelines, your radio antenna radiates measurable RF energy only while it is transmitting (talking), not when it is receiving (listening) or in standby mode.

Your M/A-COM, Inc. M7100<sup>IP</sup> mobile two-way radio complies with the following RF energy exposure standards and guidelines:

- United States Federal Communications Commission (FCC), Code of Federal Regulations; 47 CFR §§ 2 sub-part J.
- American National Standards Institute (ANSI)/Institute of Electrical and Electronic Engineers (IEEE) C95.1-1992.
- Institute of Electrical and Electronic Engineers (IEEE) C95.1-1999.

**NOTE** – Table 1 lists the recommended minimum lateral distance for bystanders in an uncontrolled and controlled environment, from transmitting types of antennas (i.e., monopoles over a ground plane, or dipoles) at rated radio power for mobile radios installed in a vehicle.

**Table 1: Rated Power and Recommended Minimum Lateral Distance**

RATED POWER OF VEHICLE-INSTALLED MOBILE TWO-WAY RADIO	RECOMMENDED MINIMUM LATERAL DISTANCE FROM TRANSMITTING ANTENNA	
	Controlled	Uncontrolled
110 Watts	92.87 cm	207.67 cm

### **Mobile Antennas**

Install the radio's antenna (M/A-COM part number 19B209568P6) in the center of the vehicle's roof. These mobile antenna installation guidelines are limited to metal body motor vehicles or vehicles with appropriate ground planes. The antenna installation should additionally be in accordance with the following.

1. The requirements of the antenna manufacturer/supplier included with the antenna.
2. Instructions in the Radio Installation Manual, including minimum antenna cable lengths.
3. The installation manual providing specific information of how to install the antennas to facilitate recommended operating distances to all potentially exposed persons.

Use only the M/A-COM approved/supplied antenna(s) or approved replacement antenna. Unauthorized antennas, modifications, or attachments could damage the radio and may violate FCC regulations.

### **Approved Accessories**

This radio has been tested and meets the FCC RF exposure guidelines when used with the M/A-COM accessories supplied or designated for use with this product. Use of other accessories may not ensure compliance with the FCC's RF exposure guidelines, and may violate FCC regulations.

For a list of M/A-COM approved accessories refer to the product manuals, M/A-COM's Products and Services Catalog, or contact M/A-COM at 1-800-528-7711.

### **Contact Information**

For additional information on exposure requirements or other information, contact M/A-COM, Inc. at 1-800-528-7711 or at <http://www.macom-wireless.com>.

# OPERATION SAFETY RECOMMENDATIONS

## TRANSMITTER HAZARDS



The operator of any mobile radio should be aware of certain hazards common to the operation of vehicular radio transmitters. **A list of several possible hazards is given:**

- **Explosive Atmospheres** – Just as it is dangerous to fuel a vehicle with the motor running, similar hazards exist when operating a mobile radio. Be sure to turn the radio off while fueling a vehicle. Do not carry containers of fuel in the trunk of a vehicle if the radio is mounted in the trunk.

**Areas with potentially explosive atmosphere are often, but not always, clearly marked. Turn OFF your radio when in any area with a potentially explosive atmosphere. It is rare, but not impossible that the radio or its accessories could generate sparks.**

- **Interference to Vehicular Electronics Systems** – Electronic fuel injection systems, electronic anti-skid braking systems, electronic cruise control systems, etc., are typical electronic systems that can malfunction due to the lack of protection from radio frequency energy present when transmitting. If the vehicle contains such equipment, consult the dealer and enlist their aid in determining the expected performance of electronic circuits when the radio is transmitting.
- **Dynamite Blasting Caps** – Dynamite blasting caps can be caused to explode by operating a radio within 500 feet of the blasting caps. Always obey the “**Turn Off Two-Way Radios**” signs posted where dynamite is being used.
- When transporting blasting caps in your vehicle:
  - Carry the blasting caps in a closed metal box with a soft lining.
  - Leave the radio **OFF** whenever the blasting caps are being put into or removed from the vehicle.



- **Liquefied Petroleum (LP) Gas Powered Vehicles** – Mobile radio installations in vehicles powered by liquefied petroleum gas with the LP gas container in the trunk or other sealed-off space within the interior of the vehicle must conform to the National Fire Protection Association standard **NFPA 58** requiring:
  - The space containing the radio equipment shall be isolated by a seal from the space containing the LP gas container and its fittings.
  - Outside filling connections shall be used for the LP gas container.
  - The LP gas container shall be vented to the outside of the vehicle.

## **SAFE DRIVING RECOMMENDATIONS**

(Recommended by AAA)

- Read the literature on the safe operation of the radio.
- Keep both hands on the steering wheel and the microphone in its hanger whenever the vehicle is in motion.
- Place calls only when the vehicle is stopped.
- When talking from a moving vehicle is unavoidable, drive in the slower lane. Keep conversations brief.
- If a conversation requires taking notes or complex thought, stop the vehicle in a safe place and continue the call.
- Whenever using a mobile radio, exercise caution.

## OPERATING RULES AND REGULATIONS

Two-way FM radio systems must be operated in accordance with the rules and regulations of the local, regional, or national government.

In the United States, the M7100<sup>IP</sup> Series mobile radio must be operated in accordance with the rules and regulations of the Federal Communications Commission (FCC). As an operator of two-way radio equipment, you must be thoroughly familiar with the rules that apply to your particular type of radio operation. Following these rules helps eliminate confusion, assures the most efficient use of the existing radio channels, and results in a smoothly functioning radio network.

When using your two-way radio, remember these rules:

- It is a violation of FCC rules to interrupt any distress or emergency message. As your radio operates in much the same way as a telephone “**party line,**” always listen to make sure that the channel is clear before transmitting. Emergency calls have priority over all other messages. If someone is sending an emergency message – such as reporting a fire or asking for help in an accident – **KEEP OFF THE AIR!**
- The use of profane or obscene language is prohibited by Federal law.
- It is against the law to send false call letters or false distress or emergency messages. The FCC requires that you keep conversations brief and confine them to business. To save time, use coded messages whenever possible.
- Using your radio to send personal messages (except in an emergency) is a violation of FCC rules. You may send only those messages that are essential for the operation of your business.
- It is against Federal law to repeat or otherwise make known anything you overhear on your radio. Conversations between others sharing your channel must be regarded as confidential.
- The FCC requires that you identify yourself at certain specific times by means of your call letters. Refer to the rules that apply to your particular type of operation for the proper procedure.
- No changes or adjustments shall be made to the equipment except by an authorized or certified electronics technician.

### **IMPORTANT!**

**Under U.S. law, operation of an unlicensed radio transmitter within the jurisdiction of the United States may be punishable by a fine of up to \$10,000, imprisonment for up to two (2) years, or both.**

## **OPERATING TIPS**

The following conditions tend to reduce the effective range of two-way radios and should be avoided whenever possible:

- Operating the radio in areas of low terrain, or while under power lines or bridges
- Obstructions such as mountains and buildings
- In areas where transmission or reception is poor, some improvement can be obtained by moving a few yards in another direction or moving to a higher elevation.

## INTRODUCTION

This manual contains installation instructions for the M7100<sup>IP</sup> Series Mobile Radio Unit and associated accessories. These instructions cover the mounting and cabling of the radio; interconnection and wiring diagrams are provided for reference. Before installation the radio should be programmed using an IBM-compatible personal computer and the following items:

Shop Programming Cable	TQ3409
Field Programming Cable	TQ3410
ProGrammer™ Software	TQ3389
	or
Conventional ProGrammer Software	TQ3385

## UNPACKING AND CHECKING EQUIPMENT

Carefully unpack the radio and identify each item in the shipping container as listed below. If damage has occurred to the equipment during shipment, file a claim with the carrier immediately. The available options for the M7100<sup>IP</sup> Series Mobile Radio are covered in Table 2.

- M7100<sup>IP</sup> Series Mobile Radio Unit
- Microphone HGMC3Z or HGMC5L
- Speaker HGLS1H
- Power Cable HGCF9A
- Control Cable HGCL1U, HGCL1V, or HGCL1W
- Front Mount Bracket Kit HGMA5N
- Remote Mount Bracket Kit HGMA5P
- Control Unit Mount Kit HGMA3J
- Operator's Manual MM102341V1
- Installation Manual MM102342V1



Figure 1 – M7100<sup>IP</sup> Series Mobile Radio Components



**Figure 2 – Rear Angle View of Radio**

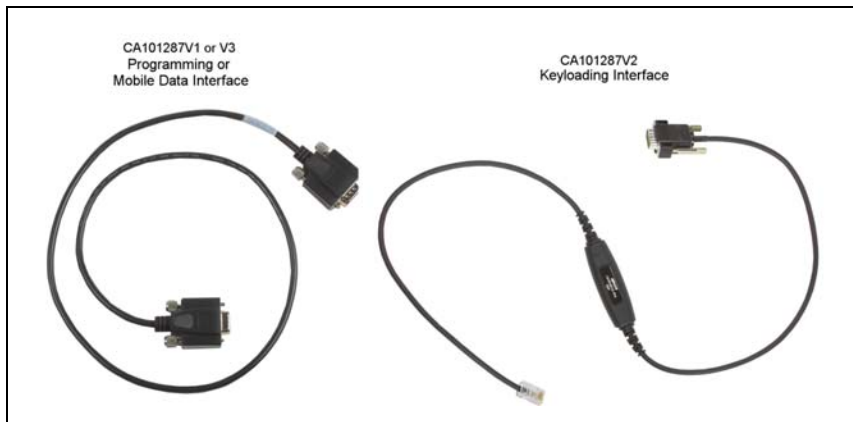

**Figure 3 – Interface Cables**



**Figure 4 - Option Cables**

**Table 2: M7100<sup>IP</sup> Series Mobile Radio Optional Accessories**

<b>OPTION</b>	<b>DESCRIPTION</b>	<b>PART NUMBER</b>
HGAN1R	VHF/UHF, ¼ Wave Whip Antenna	19B209568P6
HGCF9A	Power Cable, 7.5M (50W TX or below)	19B802622P3
<b><i>FRONT MOUNT</i></b>		
HGCL1U	Extended Option Accessory Cable	CA101288V2
<b><i>REMOTE MOUNT</i></b>		
HGCL1V	Extended Option Control Cable	CA101288V4
HGCE5T	Extended Option Accessory Cable	19B802554P7
<b><i>DUAL CONTROL</i></b>		
HGCE5Z	Dual Control Cable, Remote Mount, 9.0M	19B802554P9
<b><i>DUAL RADIO</i></b>		
HGCL1W	Dual Radio Cable, Remote Mount, 2.0M	CA101288V10
HGCL1Y	Dual Radio Extension Cable for Field Programming, Keyloading, and Mobile Data Applications	CA101288V30
HGMA3J	Mounting Bracket Kit, Remote Control Unit	344A4584G2
HGMA5N	Mounting Bracket Kit, Front Mount Radio	
HGMA5P	Mounting Bracket Kit, Remote Mount Radio	
HGMK3E	Keycap Kit, Scan Control Unit	19C852359P101
HGMK3F	Keycap Kit, System Control Unit	19C852359P102
HGMN1A	Microphone Hanger	344A4678P1
<b><i>HAND-HELD CONTROLLER KITS</i></b>		
HGZN3M	Hand-Held Controller without Siren, Remote (50W TX or Less)	
HGZN3P	Hand-Held Controller with Siren, Remote (50W TX or Less)	



## PLANNING THE INSTALLATION

Figure 5 provides an example of a typical mobile radio remote mount installation. Before starting, plan the radio installation carefully so that it will be:

- Safe for the operator and passengers,
- Away from airbag deployment area,
- Convenient for the operator to use,
- Neat,
- Protected from water damage,
- Easy to service,
- Out of the way of auto mechanics, and
- Out of the way of passengers.

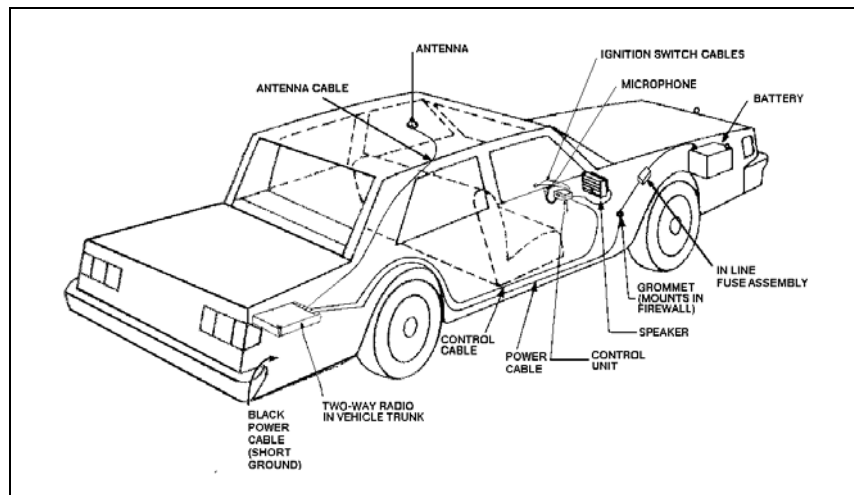

**Figure 5 – Typical Installation (Remote Mount Shown)**

It is suggested that the radio be installed by one of the many M/A-COM Authorized Service Centers located throughout the United States. Their experienced service personnel can provide a proper radio installation and make any final adjustments that may be needed.



**Vehicular Electronics** - Electronic fuel injection systems, electronic anti-skid braking systems, electronic cruise control systems, etc., are typical of the types of electronic devices which might be prone to malfunction due to the lack of protection from radio frequency energy present when a radio is transmitting. If the vehicle contains such equipment, consult the dealer to determine if such electronic equipment will perform normally when the radio is transmitting.



**Air Bags** – For driver and passenger safety, avoid mounting the radio above or near airbag deployment areas. Note that vehicles might contain front driver and passenger side airbags as well as side airbags. For occupant safety, verify the location of all airbags before installing radio equipment.



For passenger safety, mount the radio securely so that the unit will not break loose in the event of a collision. This is especially important in station wagons, vans and similar type installations where a loose radio could be extremely dangerous to the vehicle occupants.

## EQUIPMENT REQUIRED

The equipment required for installing the M7100<sup>IP</sup> Series Mobile Radio is listed below:

- Crimping tool for fuse holder
- Electric drill for drilling mounting holes
- Drills and circle cutters, as follows:
  - No. 31 (1/8-inch) drill
  - No. 27 (9/64-inch) drill
  - 5/8-inch drill or circle cutter
  - 3/4-inch circle cutter, hole saw or socket punch
- Phillips and flat-blade screwdrivers
- POZIDRIV<sup>®</sup> driver
- No. 20 Torx<sup>®</sup> driver



Be careful to avoid damaging some vital part (fuel tank, transmission housing, etc.) of the vehicle when drilling mounting holes. Always check to see how far the mounting screws will extend below the mounting surface before installing.



If pilot holes must be drilled, remove all metal shavings from drilling holes before installing screws.

# INSTALLATION

## RUNNING CABLES

To assure the feasibility of the planned cable routings, it is suggested that the cables be run before mounting the radio. The M7100<sup>IP</sup> Series mobile radio may be installed as a Front Mount or a Remote Mount. The type of mount, the application and the options to be installed should be considered when planning the cable runs. Figure 6 and Figure 7 provide Interconnection Diagrams for typical installations. Figure 6 and Figure 7 should be referenced throughout this manual and throughout the installation.

Be sure to leave some slack in each cable going to the radio so that the radio may be pulled out for servicing with the power applied and antenna attached. Coil any surplus cables and secure them out of the way. Try to route the cables away from locations where they will be exposed to heat (exhaust pipes, mufflers, tailpipes, etc.), battery acid, sharp edges or mechanical damage or where they will be a nuisance or hazard to automobile mechanics, the driver or passengers. Keep wiring away from electronic computer modules, other electronic modules and ignition circuits to help prevent interference to these components and radio equipment.

In addition, try to utilize existing holes in the firewall, trunk wall and the channels above or beneath doors. Channels through door and window columns that are convenient for running cables may also be used, unless rigid or flexible conduit is to be installed for cable runs.

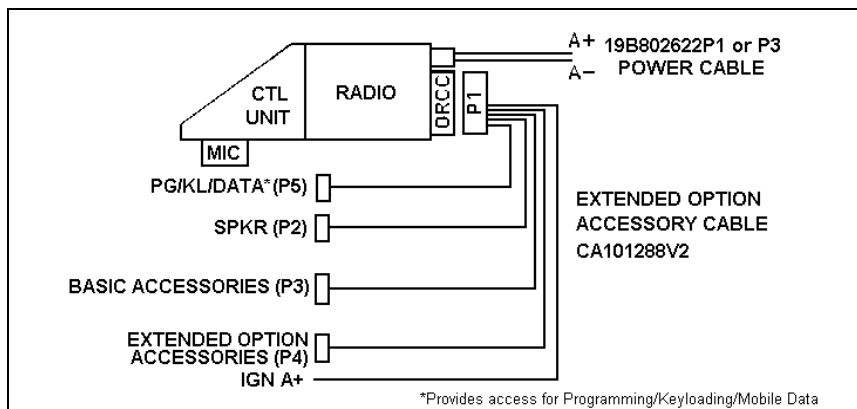

**Figure 6 – Front Mount Extended Option Accessory Interconnections**

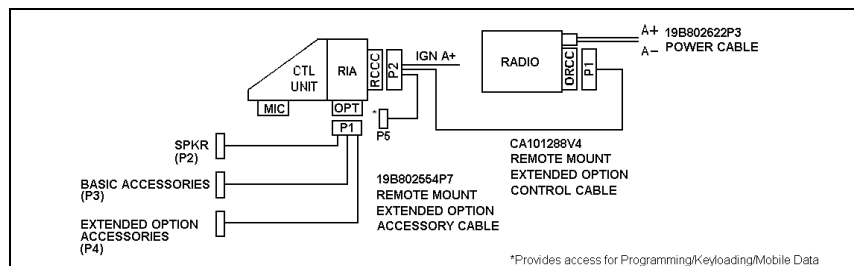

**Figure 7 – Remote Mount Extended Option Accessory Interconnections**

### **Power Cable**

The power cable (19B802622P3) consists of a red lead A+ and a black lead A- connected to a molded 2-pin power connector and supplied with ring terminals (refer to Figure 8). To install the power cable:

1. Drill a 5/8-inch hole in the firewall for the cable run and insert the rubber grommet. Run the cable through this grommet to the battery location. Secure the cable at several locations within the engine compartment to prevent possible damage to cable.
2. Strip back the insulation approximately 3/8 of an inch from the end of the black lead. Slide one of the large heat shrink sleeves onto the wire and crimp a battery ring terminal onto this lead. Heat-shrink the sleeve over the crimp connection. Connect the black lead directly to the battery negative (-) or ground frame member.
3. Cut off 12-18 inches from the red lead. Strip back the insulation approximately 3/8 of an inch on each end of the wires. Insert the wire ends into the small openings at the end of each fuse holder section and crimp a fuse connector to each wire. Prepare the other end of the short wire in the same manner as in Step 2 of this procedure and connect to the positive (+) terminal of the battery.



**NOTE**

Do not install the fuse holder until the installation is completed and all connections have been checked.



**NOTE**

Power Cable 19B802622P3 is used only with radios with 50 watts or less RF power output.

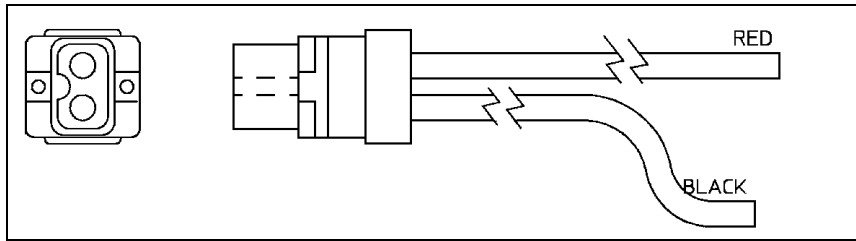

**Figure 8 – Power Cable 19B802622P3**

### **Accessory Cable**

#### **Front Mount**

The Front Mount Extended Option Accessory Cable, at one end, consists of the extended options plug (P4); basic accessories connector (P3); connection for field programming, keyloading, and mobile data applications (P5); the speaker connector (P2); and the ignition sense lead. At the other end is plug P1. P1 connects to the Option/Remote Control Connector (ORCC) which is mounted on the back of the radio (refer to Figure 9).

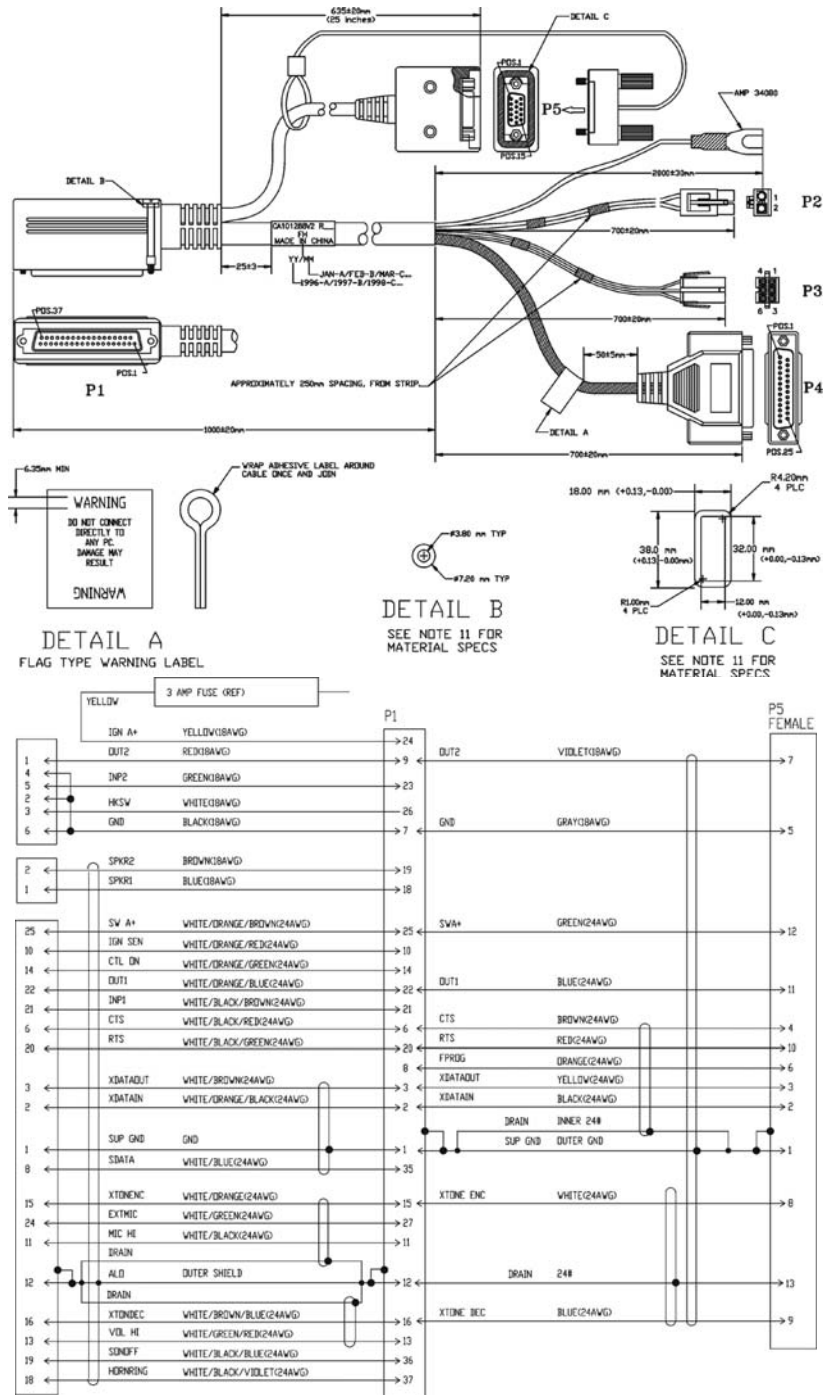

Figure 9 - Front Mount Extended Option Accessory Cable CA101288V2

## Remote Mount

The Remote Mount Extended Option Accessory Cable, at one end, consists of the extended option plug (P4), the basic accessories connector (P3), and the speaker connector (P2). At the other end is the plug P1. P1 will connect to the Option Connector (OPT) which is mounted on the back of the Radio Interface Adapter (RIA). See Figure 10.

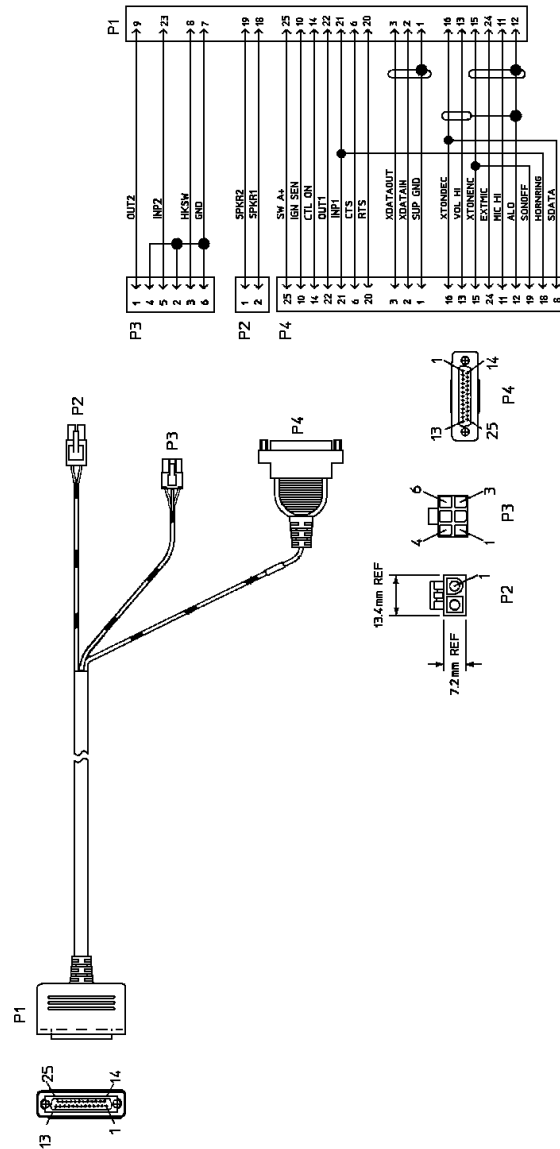

Figure 10 - Remote Mount Extended Option Accessory Cable  
19B802554P7



## **Ignition Sense (All Applications)**



### **NOTE**

The radio, as shipped from the factory, has the "ignition sense" feature disabled. As such, the radio will be powered ON or OFF as determined by the front panel ON/OFF/VOLUME control only (assuming A+ and A- are connected). If it is desired to enable the "ignition sense" feature, open the top cover of the radio and remove the shield from logic PWB. Slide switch SW601 from position 3-2 to 1-2. Replace shield and top cover. Be sure to apply correct torque to screws holding top cover in place (refer to the appropriate Maintenance Manual).



### **NOTE**

The "Accessory" point should drop to ZERO volts when cranking the engine and return to +12 volts after the engine is started. If a point is chosen that drops to a voltage between zero and +12 volts, the radio might execute a power-up cycle several times during start up. It is recommended that the terminal be measured with a voltmeter to be sure it shuts off (goes to zero volts) during the cranking of the engine.

The fuse holder must be attached to the yellow sense lead along with the ring terminal as follows:

1. Cut the yellow sense lead approximately 6-12" from the end that will be connected to the power source.
2. Strip the insulation from each end of the short lead and from the end of the long lead at least 3/8".
3. Insert the stripped end of the long lead and one end of the short lead into the narrow end of each fuse holder half.
4. Crimp the leads in the fuse holder halves with a crimping tool.
5. Insert the 3-amp fuse into one end of the fuse holder and join the two fuse holder halves firmly together.
6. Attach the ring terminal to the end of the short lead and connect this lead to the ignition "ON" sense point [preferably an "Accessory" point (in the vehicle fuse panel) that is switched on when the vehicle ignition switch is in the ACCESSORY and RUN positions].



**CAUTION**

Certain problems might be encountered when accessory equipment is connected to the ignition or accessory lines of the vehicle, where these lines can have large filter capacitors and a leakage path present. If the radio does not turn off within a reasonable amount of time after the ignition is turned off, first try a different accessory or ignition sense pick-up point in the vehicle. Many vehicles have more than one circuit that is switched by the ignition switch, and one might be available that does not have large filter capacitors or a leakage path present.

If a different pick-up point cannot be found, add a 470-ohm, 1-watt resistor from the ignition sense pick-up point to ground. This will discharge the capacitor(s) or reduce the leakage voltage to a low value. Current drain through this resistor will be minimal (less than 0.03A) when the ignition is switched on.

### **Control Cable (Remote Mount Only)**

The Control Cable is used to connect the Control Unit (through the RIA) to the Radio Transceiver in remote applications. Plug P2, at one end, connects to the Remote Control Cable Connector (RCCC) mounted on the back of the RIA. The Ignition Sense wire is also part of P2. The connection, P5, is available for field programming, keyloading, or mobile data applications. The other end of the Control Cable (P1) connects to the ORCC mounted on the back of the radio. See Figure 11.

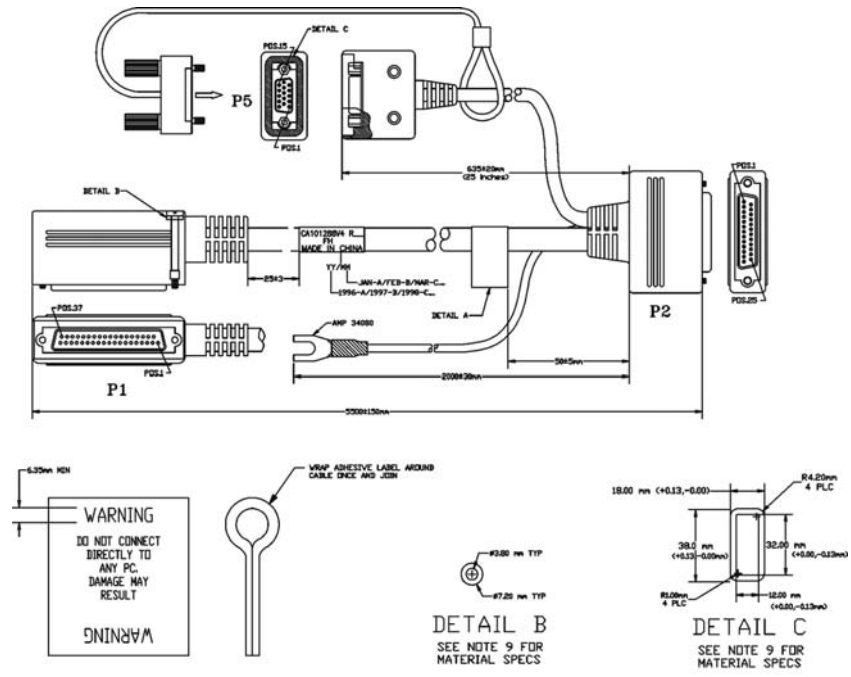

DETAIL A  
FLAG TYPE WARNING LABEL

DETAIL B  
SEE NOTE 9 FOR MATERIAL SPECS

DETAIL C  
SEE NOTE 9 FOR MATERIAL SPECS

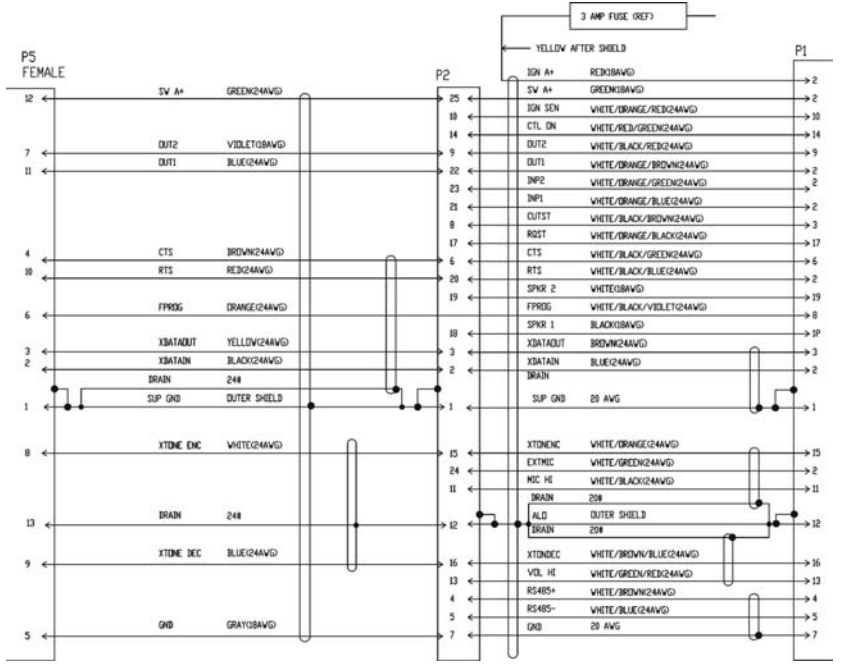
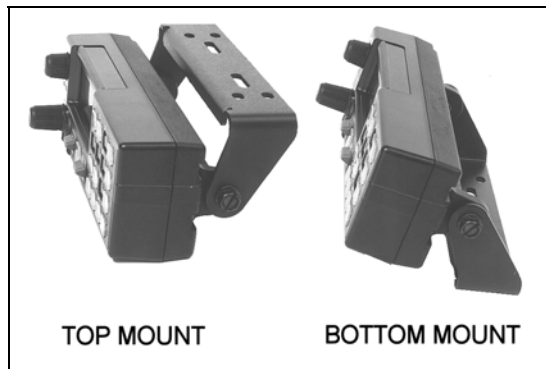

Figure 11 – Remote Extended Option Control Cable (CA101288V4)



**Figure 12 – Control Unit Mounting Bracket Installation**

## **CONTROL UNIT MOUNTING**

*(Remote Applications Only)*

1. Using the bracket as a template, mark and drill the mounting holes. Be sure to leave enough room at the rear of the control unit for the cable connector. Refer to Figure 12 for control unit mounting bracket installation.
2. Secure the mounting bracket using the four No. 10 x 3/4 self-tapping screws supplied (use No. 10 x 1-1/2 if needed.).
3. Secure the control unit to the bracket with the two 1/4-20 x 5/8 hex head screws and lock washers provided.

## **PIGTAIL BRACKET**

The Pigtail Bracket is used to mount the DB15 connector for easier user access. The DB15 connector is used to make radio programming and keyloading by the customer easier, eliminating the need to dismantle the radio or Control Unit. There are two Pigtail brackets: one for use with the Control Unit and one for use with the radio mounting bracket. The following section includes procedures to mount the Pigtail brackets in each of these configurations.

### **Pigtail Bracket – Control Unit Mounting**

For Control Unit mounting, the pigtail bracket is attached to the side of the Control Unit bracket using existing mounting bracket hardware. The Pigtail Bracket can be mounted to either the right or the left side of the Control Unit. Hardware Kit, KT101533V6, contains Pigtail mounting bracket and hardware required to attach Pigtail to bracket.



**Figure 13 – Control Unit Mounting Bracket with Pigtail Bracket**

1. Attach DB15 connector to the rectangular end of bracket with 2 pan head machine screws and washers. See Figure 14.



**Figure 14 – DB15 Connector Mounted on Control Unit Pigtail Bracket**

2. Remove the ¼-20X5/8 hex head screw and washer from the side of the Control Unit bracket where the Pigtail installation is desired. Retain this hardware for Step 4.
3. Align the single hole at the end of the Pigtail Bracket with the holes in the Control Unit bracket and the Control Unit.
4. Replace washer, insert hex head screw, and tighten. See Figure 15.



**Figure 15 – Pigtail Bracket Installed on Control Unit**

### **Pigtail Bracket – Radio Mounting**

For Radio mounting, the Pigtail Bracket is attached to either side of the Radio mounting bracket. Hardware Kit, KT101533V5, contains the Pigtail Bracket, hardware to attach the Pigtail to the bracket.

1. Attach DB15 connector to rectangular end of the Pigtail Bracket using 2 pan head machine screws and washers. See Figure 16.



**Figure 16 – DB15 Connector Mounted on Radio Pigtail Bracket**

2. Position the Pigtail Bracket with the connector facing away from the side and towards the front of the radio. The Pigtail Bracket can be installed on either side of the radio.
3. Remove the first two radio mounting bracket screws and lockwashers located closest to the front of the radio. Retain this hardware for Step 5.
4. Align the bracket hole at the smaller end of the Pigtail Bracket with the middle hole on the radio bracket and the corresponding hole in the radio chassis. Insert an M4 x 10mm hex head screw and lockwasher and loosely tighten.
5. The other slot in the Pigtail Bracket will enable flexible positioning of the pigtail. Position the bracket, insert the remaining M4 x 10mm hex head screw and lockwasher. Tighten both of the hex head screws to maintain the desired Pigtail position. See Figure 17.

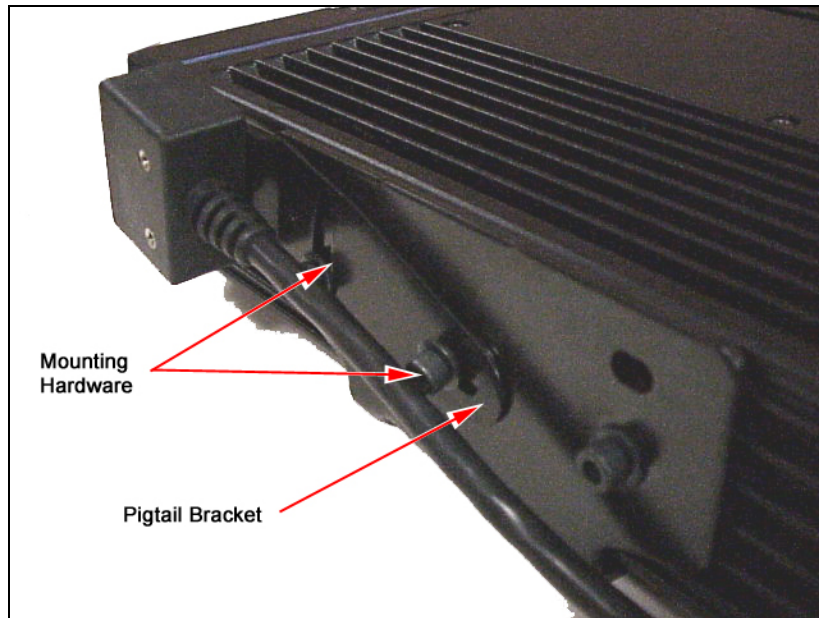

**Figure 17 – Pigtail Bracket Mounted on Radio**

## **SPEAKER**

The speaker kit includes the speaker, mounting bracket and connecting cable. Mount the speaker so it is directed to the operator but does not present a hazard in the event of an accident. The speaker may be mounted on the lower edge of the instrument panel, the firewall or above the windshield in some trucks.

1. Use the mounting bracket as a template for locating the mounting holes and mount the speaker as shown in Figure 18.
2. Refer to the applicable installation procedures for connection of the speaker to the accessory cable.

## MICROPHONE HANGER AND/OR HOOKSWITCH MOUNTING

The microphone hanger or hookswitch should be mounted in a location convenient to the operator where it will not interfere with the safe operation of the vehicle or be a hazard to the vehicle passengers. The hanger and hookswitch are designed to be mounted with the open end of the mounting button slot pointed upward. Use the hanger or hookswitch as a template to mark and drill the mounting holes. Mount the hanger or hookswitch with the self-tapping screws provided.

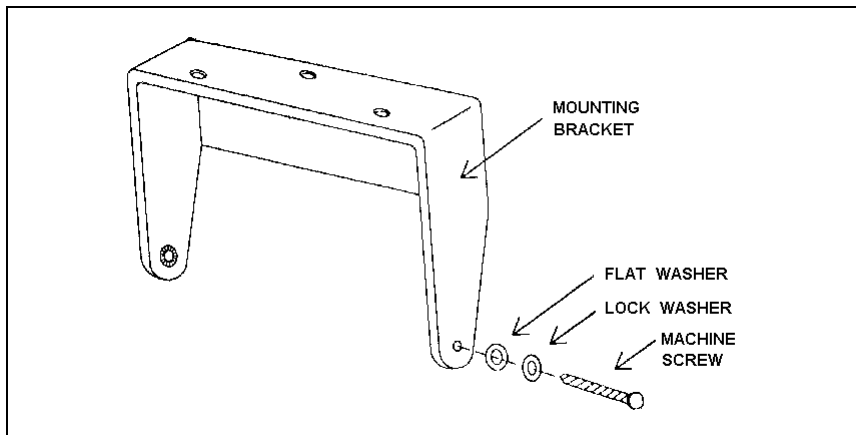

**Figure 18 – Speaker Mounting Bracket**

## SIREN AND LIGHT

For instructions about installing the Federal Signal Corporation Siren and Light Kit, refer to the Federal Signal Corporation Installation Instructions (Federal Systems part number 255287B, rev. B or higher).

Program the radio to work with the Federal Systems Siren and Light Kit, using the instructions outlined in the ProGrammer On-Line Help.

NOTE: The following issues have been reported on some M7100<sup>IP</sup> Siren/Light installations using the Federal Signal Corporation Siren and Light Kit:

- Occasional false activation of siren and light functions when the ignition is turned to the “on” position and/or when the vehicle is started.



- Occasional failure to enable siren or light functions via control head, which can be temporarily resolved by either power cycling the radio or turning the car ignition “off” and then “on” again.

To resolve these issues above, modify the Federal Systems control cable as follows:

1. Remove the outer shell from the DB25 side of the Federal Systems control cable.
2. Add a jumper from pin 1 to pin 19.

This modification to the SS2000 cable harness will disable the M7100<sup>IP</sup>'s capability to turn on and off the SS2000 from the front of the control head. The SS2000 will now be turned on and off strictly by its own ignition switch trigger line (red wire from 12 pin Molex connector on SS2000 siren box). Follow the SS2000 Federal Signal Corporation installation instructions to attach the red ignition line correctly.

## **RADIO MOUNTING AND FINAL HOOK-UP**

### **Front Mount**

Typically, the bracket shown in Figure 19 is used for Front Mount applications. The bracket can be mounted so that it is either above or below the radio for the user's convenience. The bracket pictured in Figure 12 can also be used for Remote Mount applications. The following instructions are for a Front Mount installation using the bracket shown in Figure 19.

1. Use the supplied mounting bracket as a template to locate the position for each of the drill holes. Be sure to leave enough room at the front and rear of the radio for cable connections. Drill No. 27 (9/64) pilot holes.
2. Mount bracket with four 1/4"-14 x 3/4" sheet metal screws (use 1/4"-14 x 1-1/2" screws if needed).
3. Place radio into mounting bracket and secure with the four M4 x 10 mm hex head screws, M4 flat washers and M4 lock washers supplied using a No. 20 Torx driver.
4. Connect antenna coaxial cable to antenna connector (TNC).
5. Connect front mount accessory cable connector P1 to the Option/Remote Control Connector (ORCC) and secure with the two captive screws in the connector to the radio.

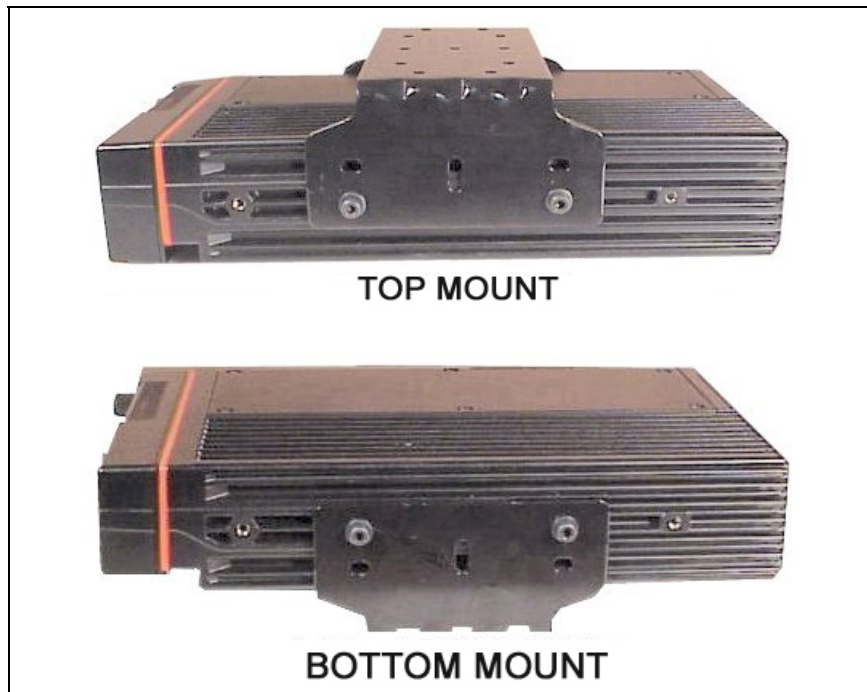

**Figure 19 – Mounting Bracket Installation**

6. Connect front mount accessory cable connector P2 to speaker cable connector.
7. Connect power cable to power connector on rear of radio unit and secure with the two captive screws to the radio unit.
8. Connect the microphone connector to the connector on the front panel and secure with the captive screw.



**NOTE**

Do not torque the microphone connector screw greater than 2 in-lb. Alternatively, “finger tight plus 1/4 turn” is acceptable.

9. If there are no other accessory connections, tie back plug P3 to main cable.
10. Recheck all connections before inserting fuse into transmit fuse assembly.

**Remote Mount Installation**

The bracket shown in Figure 20 is used in Remote Mount configurations. In some applications, the bracket shown in Figure 19 can also be used for

Remote Mount installations. The following instructions are for a Remote Mount installation using the bracket shown in Figure 20.

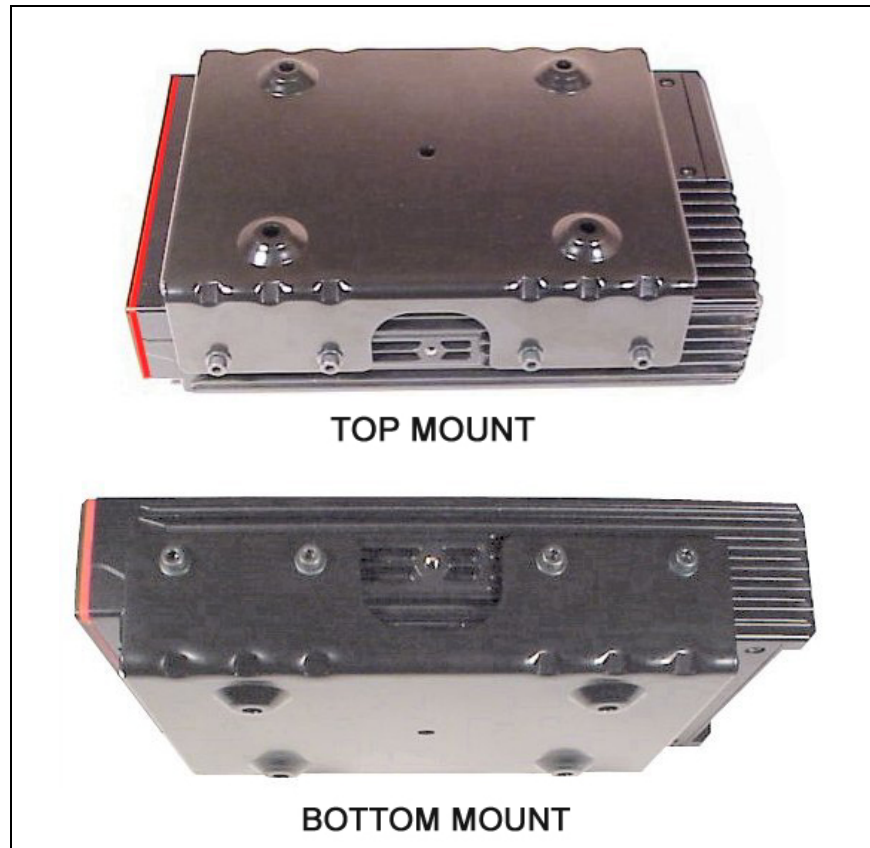

**Figure 20 – Remote Mounting Bracket Installation**

1. Using the bracket as a template, mark and drill the mounting holes using a No. 27 drill. Be sure to leave enough room at the rear of the radio unit for the cable connections.
2. Secure the mounting bracket using four 1/4"-14 x 3/4" sheet metal screws (use 1/4"-14 x 1" if needed.) The bracket can be used mounted so that it is either above or below the radio for the user's convenience.
3. Slide the radio unit into the bracket by aligning bracket guides with grooves on each side of radio (rear of radio should be inserted first). Slide radio back until screw holes in front of bracket align with screw holes in side of radio. See Figure 20.
4. Secure radio to the bracket with two M4 x 10 mm socket head screws provided.

5. Connect antenna coaxial cable to antenna connector (TNC).
6. Connect remote control cable connector P1 to the ORCC connector on the radio unit and secure with the two captive screws.
7. Connect other end of remote control cable to the remote control cable connector (RCCC) on the remote control unit.
8. Connect remote mount accessory cable connector P1 to the option connector (OPT) on control unit. Then connect the speaker to connector P2 and accessory connector P3 to any options (hookswitch, etc.). If connector P3 is not used, insulate and tie back to main cable.
9. Recheck all connections and cables. Insert fuse into transmit fuse assembly.

## DUAL CONTROL UNITS

The Dual Control feature can be configured for either front mount or remote mount radio units. Each configuration provides for a Main Control Unit and an Auxiliary Control Unit. In the front mount configuration, the Main Control Unit is on the Radio Unit itself, with the Auxiliary Control Unit located in a convenient location (see Figure 21A). In the remote mount configuration, the Main Control Unit is typically located in the vehicle cab, with the Auxiliary Control Unit located in a convenient location (see Figure 21B).

All radio units and control units in the Dual Control configuration **MUST BE PROGRAMMED** prior to final installation. It is recommended that the units be first programmed at an Authorized Service Center, and then transferred to the user's installation.

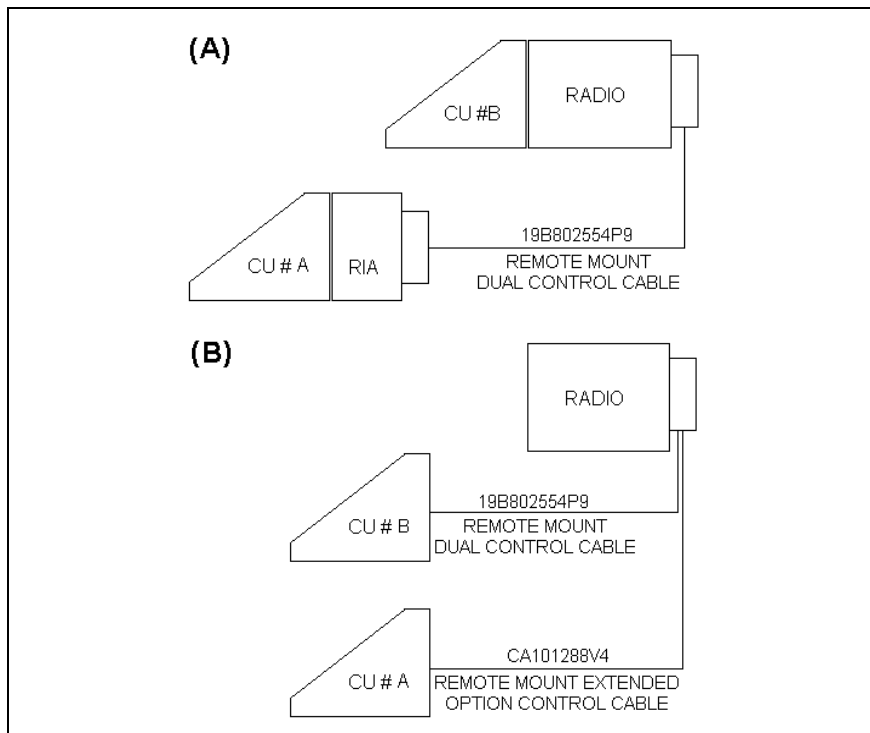

**Figure 21 – Dual Control Unit – Basic Configurations for Front Mount and Remote Mount Installations**

## PRE-INSTALLATION PROGRAMMING PROCEDURE WITH PROGRAMMER - FRONT MOUNT

The Radio and Control Units must be programmed in a sequential procedure, in order to provide each Control Unit with the proper identification code.

1. Configure the M7100<sup>IP</sup> Front Mount Radio with ProGrammer Assembly, as shown in Figure 22, Step 1. Program the radio with the following control configurations:

### Network Options

Dual Control	Enable
Audio Mode	Active
Switching Mode	Independent
Siren Light Controller	Unit A
Siren Light Connection	Unit A
Speaker	Disable
Multiple Radio	Disable

### Program Radio Setup

Mobile Options	Push Button
----------------	-------------

### M7100<sup>IP</sup> Options

Write System Keypad File	Enable (System control unit)
Write Scan Keypad File	Enable (Scan control unit)
Personality Name <USERPERS>	User's personality file Radio Code OGXXXXX Latest radio code file (G13 or later version)
ADI Code	<SAME>
Radio Unit ID	<SAME>
Keypad File	<CUBMAP> Keypad definition for Control Unit B
CU ID (CU B)	Must be Control Unit B

2. Now configure the Front Mount Radio and the Auxiliary Control Unit together with ProGrammer, as shown in Figure 22, Step 2. Program this configuration with the following files:

### Network Options

Dual Control	Enable
--------------	--------

Audio Mode	Active
Switching Mode	Independent
Siren Light Controller	Unit A
Siren Light Connection	Unit A
Speaker	Disable
Multiple Radio	Disable
<b>Program Radio Setup</b>	
Mobile Options	Push Button
<b>M7100<sup>IP</sup> Options</b>	
Write System Keypad File	Enable (System control unit)
Write Scan Keypad File	Enable (Scan control unit)
Personality Name	<USERPERS> User's personality file
Radio Code	<SAME>
ADI Code	<SAME>
Radio ID	<SAME>
Keypad Files	<CUAMAP> Keypad definition for Control Unit A
CU ID (CU A)	Must be Control Unit A

Note that the Main Control Unit has ID "B" and the Auxiliary Control Unit has ID "A" in this configuration.

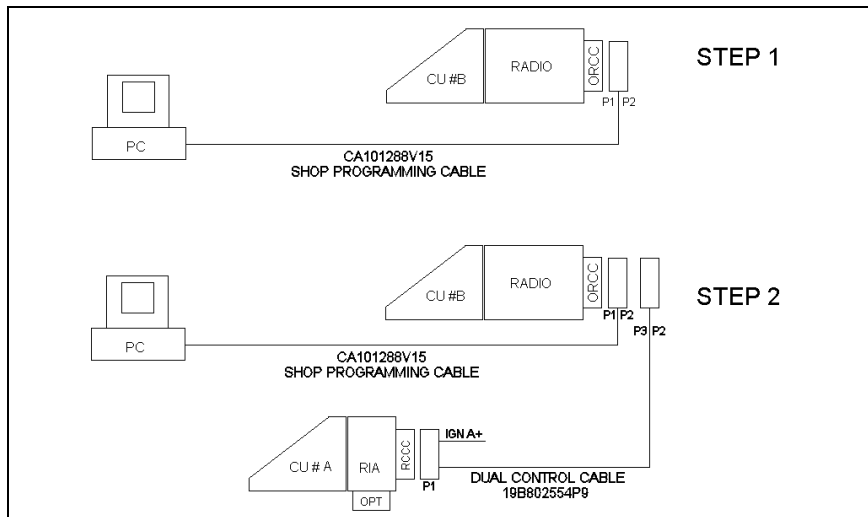

**Figure 22 – M7100<sup>IP</sup> Dual Control Unit PC Programming Configuration**

## **PRE-INSTALLATION PROGRAMMING PROCEDURE WITH PROGRAMMER - REMOTE MOUNT**

The Radio and Control Units must be programmed in a sequential procedure, in order to provide each Control Unit with the proper identification code.

1. Configure the M7100<sup>IP</sup> Remote Mount Radio with ProGrammer Assembly, as shown in Figure 23, Step 1. Program the radio with the following control configurations:

### **Network Options**

Dual Control	Enable
Audio Mode	Active
Switching Mode	Independent
Siren Light Controller	Unit A
Siren Light Connection	Unit A
Speaker	Disable
Multiple Radio	Disable

### **Program Radio Setup**

Mobile Options	Push Button
----------------	-------------

### **M7100<sup>IP</sup> Options**

Write System Keypad File	Enable (System control unit)
--------------------------	------------------------------



Write Scan Keypad File	Enable (Scan control unit)
Personality name <USERPERS>	User's personality file
Radio Code OGXXXXX	Latest radio code file (G13 or later vintage)
ADI Code	<SAME>
Radio Unit ID	<SAME>
Keypad File	<CUBMAP> Keypad definition for Control Unit B
CU ID (CU B)	Must be Control Unit B

2. Now configure the Remote Mount Radio and the Auxiliary Control Unit together with ProGrammer, as shown in Figure 23, Step 2. Program this configuration with the following files:

**Network Options**

Dual Control	Enable
Audio Mode	Active
Switching Mode	Independent
Siren Light Controller	Unit A
Siren Light Connection	Unit A
Speaker	Disable
Multiple Radio	Disable

**Program Radio Setup**

Mobile Options	Push Button
----------------	-------------

**M7100<sup>IP</sup> Options**

Write System Keypad File	Enable (System control unit)
Write Scan Keypad File	Enable (Scan control unit)
Personality Name <USERPERS>	User's personality file
Radio Code	<SAME>
ADI Code	<SAME>
Radio ID	<SAME>
Keypad File <CUAMAP>	Keypad definition for Control Unit A
CU ID (CU A)	Must be Control Unit A

Note that the Main Control Unit has ID “A” and Auxiliary Control Unit has ID “B” in this configuration.

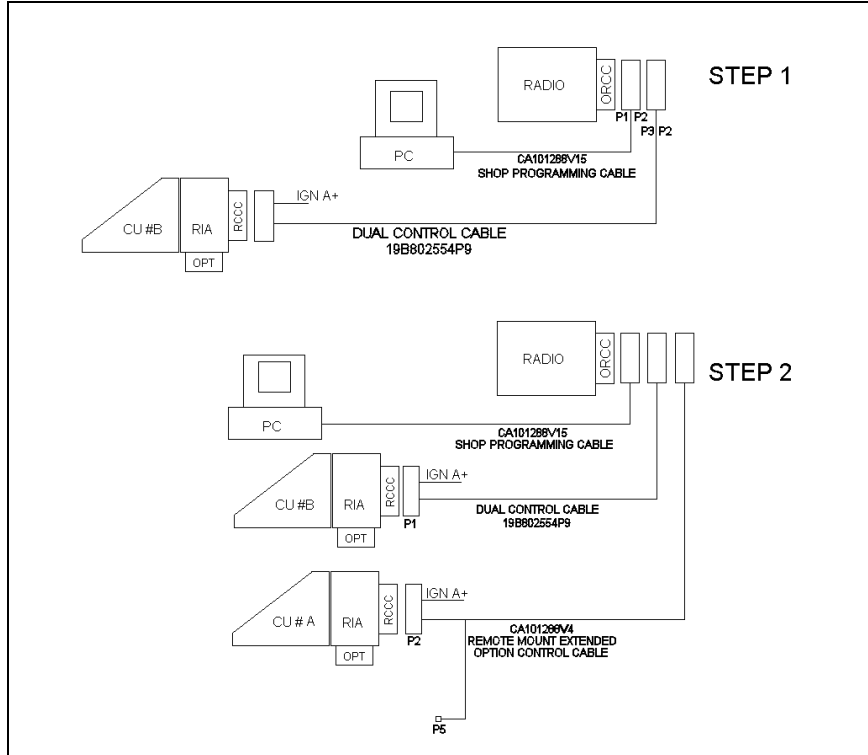

**Figure 23 – M7100<sup>IP</sup> Dual Control Unit PC Programming Configuration Remote Mount**

## INSTALLATION INSTRUCTIONS FOR FRONT MOUNT DUAL CONTROL UNITS

The Dual Control Unit feature is configured such that only one control unit can be used for Extended Option accessories. **All Extended Option functions are only available at the Main Control Unit.**

1. Referring to Figure 24, run the Dual Control Cable (19B802554P9) between locations for the Radio Unit and Auxiliary Control Unit. Be sure to locate the P2/P3 connector assembly at the Radio Unit.
2. After installing Radio Unit mounting hardware in the normal fashion, connect the Dual Control Cable connector (P3) to the Radio Unit. Tighten the two jackscrews on P3. Next, connect the Accessory Cable (CA101288V2) Connector (P1) to the Dual Control Cable Connector (P2), and tighten the jackscrews on P2. Connect the power cable, and install Radio Unit in mounting bracket.

3. After installing the Auxiliary Control Unit in the normal fashion, connect the Dual Control Cable (P1) to Auxiliary Control Unit, and tighten jackscrews.
4. Connect the Remote Mount Accessory Cable (19B802554P7) to the Auxiliary Control Unit.
5. A yellow Ignition Sense lead is provided on the Dual Control Cable and the Front Mount Accessory Cable. If the “**Ignition Sense**” feature is enabled on the Radio Unit, it is necessary to connect only one of the yellow leads provided, whichever is convenient. Tape back the unused yellow lead (see Page 25 for details).
6. Install the Speakers in convenient locations near the Radio Unit and Auxiliary Control Unit.

### **Parallel Audio Installation Requirements**

In special configurations that require both speakers to operate at the same time (simultaneous audio), install the speakers for parallel audio operation.

Refer to Figure 25 for the Parallel Audio Setup Installation. Perform the following steps to install parallel audio speakers:

- A. Use the two 8 $\Omega$  speakers, part number 19A149590P12, in place of the two 4 $\Omega$  speakers, part number 19A149590P11.
- B. Hardwire each speaker directly (without relays) as shown in Figure 24.

#### **NOTE**

**It is very important to use the correct speakers for this application. Wiring 4 $\Omega$  speakers in this configuration can cause damage to the radio.**

7. Install a relay (19A149299P1) from the kits supplied at a location near the leads from each speaker. For mounting, use the #8x3/4” sheet metal screw and nut plate supplied with each kit.
8. At a convenient point cut one of the wires in each of the 2-wire speaker cables, spread the leads, and strip the ends. Crimp a 1/4” tab receptacle to each end.
9. Radio Unit Speaker: Connect the lead nearest the speaker to Pin 87A of the relay. Connect the lead nearest the connector to Pin 30 of the relay. Connect the connector to the Accessory Cable P2 (Refer to Figure 24).
10. Auxiliary Control Unit Speaker: Connect the lead nearest the speaker to Pin 87 of the relay. Connect the lead nearest the connector to Pin 30 of the relay. Connect the connector to the Accessory Cable P2 (Refer to Figure 24).

11. For each relay: Connect a #18 AWG black wire between the relay, Pin 85 and Accessory Cable P3-1 (labeled “OUT2” on the schematic diagrams in the service manual). Use a 1/4” tab receptacle on the relay side and mating Molex connector and pins on the accessory cable side. Connect the mating Molex connector to the Accessory Cable P3 when finished (Refer to Figure 24).
12. For each relay: Connect a #18 AWG red wire to the relay, Pin 86. Cut to length, and connect to the 1A fuse holder (supplied). Use crimp on connectors supplied. Connect the other side of the 1 amp fuse holder to A+ battery source or vehicle A+ fuse block. Use #18 AWG red wire and ring lug supplied, if needed (see Figure 24).
13. Check dual control operation, using operator’s manual as a test guide. In ProGammer, make sure the “DUAL CONTROL SPEAKER” is programmed **ACTIVE LOW**.

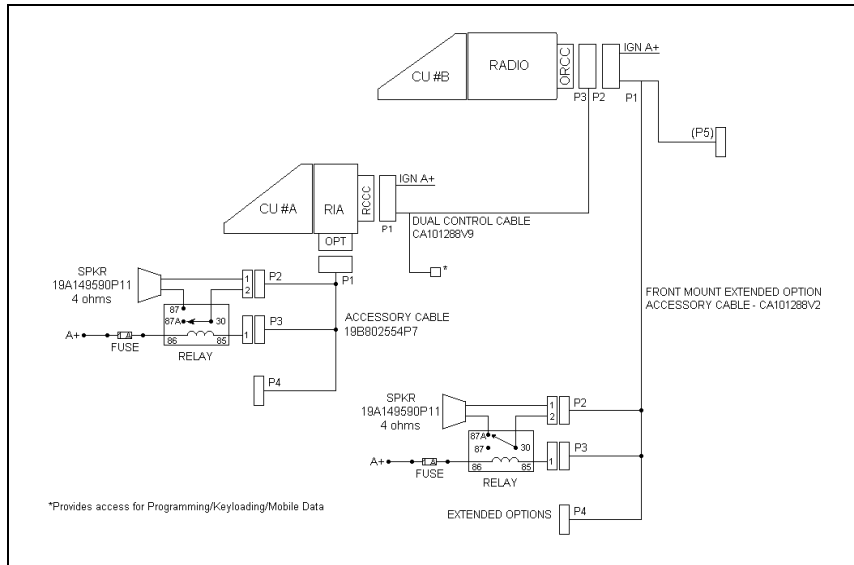

**Figure 24 – M7100<sup>IP</sup> Dual Control Unit Front Mount/Remote Mount Installation Configuration**

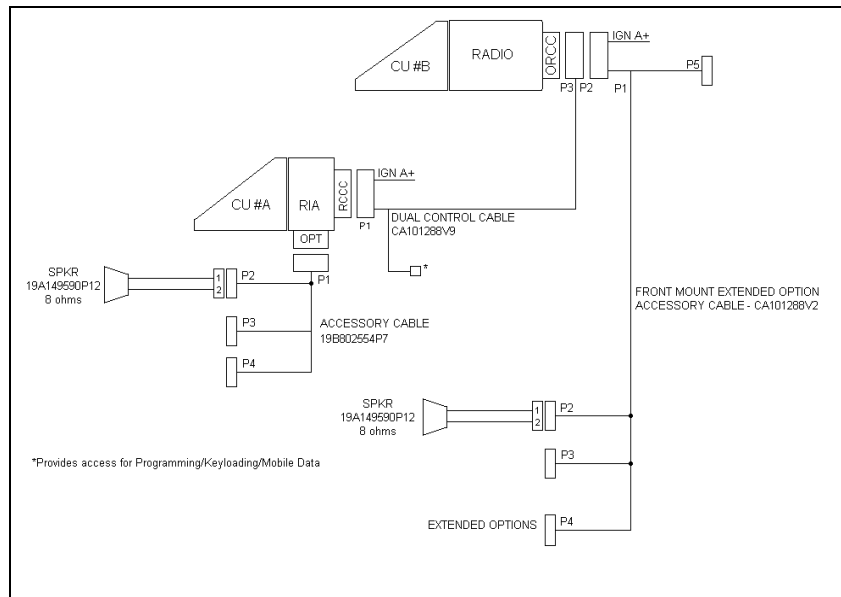

**Figure 25 – M7100<sup>RP</sup> Dual Control Unit Front Mount/Remote Mount Installation Configuration – Parallel Audio**

## INSTALLATION INSTRUCTIONS FOR REMOTE MOUNT DUAL CONTROL UNITS

1. Referring to Figure 26, run the Remote Control Cable (CA101288V4) between locations for the Radio Unit and Main Control Unit.
2. Run the Dual Control Cable (19B802554P9) between locations for the Radio Unit and Auxiliary Control Unit. Be sure to locate the P2/P3 connector assembly at the radio unit.
3. After installing the Radio Unit in the normal fashion, connect the dual control cable connector (P3) to the Radio Unit. Tighten the two jackscrews on P3. Next, connect the Remote Control Cable connector (P1) to the Dual Control Cable connector (P2), and tighten jackscrews on P2.
4. After installing the Main Control Unit in the normal fashion, connect the Remote Control Cable (P2) to the Main Control Unit, and tighten jackscrews.
5. After installing the auxiliary control unit in the normal fashion, connect the Dual Control Cable (P1) to the Auxiliary Control Unit, and tighten jackscrews.
6. Connect the Remote Mount Extended Option Accessory Cable (19B802554P7) to the Auxiliary Control Unit and the Main Control Unit.

**Please note: All extended option functions are only available at the Main Control Unit.**

7. A yellow ignition sense lead is provided on each control cable. If the “**Ignition Sense**” feature is enabled on the Radio Unit, it is necessary to connect only one of the yellow leads provided, whichever is convenient. Tape back the unused yellow lead. See page 25 for details.
8. Install the speakers in convenient locations near each control unit.

### **Parallel Audio Installation Requirements**

In special configurations that require both speakers to operate at the same time (simultaneous audio), install the speakers for parallel audio operation.

Refer to Figure 28 for the Parallel Audio Setup Installation. Perform the following steps to install parallel audio speakers:

- A. Use the two 8Ω speakers, part number 19A149590P12, in place of the two 4Ω speakers, part number 19A149590P11.
- B. Hardwire each speaker directly (without relays) as shown in Figure 26.

#### **NOTE**

**It is very important to use the correct speakers for this application, wiring 4Ω speakers in this configuration may cause damage to the radio.**

9. Install a relay (19A149299P1) from the kits supplied at a location near the leads from each speaker. For mounting, use the #8 X 3/4” sheet metal screw and nut plate supplied with each kit.
10. At a convenient point cut one of the wires in each of the 2-wire speaker cables, spread the leads, and strip the ends. Crimp a 1/4” tab receptacle to each end.
11. Main Control Unit Speaker: Connect the lead nearest the speaker to Pin 87 of the relay. Connect the lead nearest the connector to Pin 30 of the relay. Connect connector to the accessory cable P2 (Refer to Figure 27).
12. Auxiliary Control Unit Speaker: Connect the lead nearest the speaker to Pin 87A of the relay. Connect the lead nearest the connector to Pin 30 of the relay. Connect the connector to accessory cable P2 (Refer to Figure 27).
13. For Each Relay: Connect a #18 AWG black wire between the relay, Pin 85 and accessory cable P3-1 (labeled “**OUT2**” on schematic diagrams in the service manual). Use a 1/4” tab receptacle on the relay side and a mating Molex connector and pins on the accessory cable side. Connect the mating Molex connector to the accessory cable P3 when finished (Refer to Figure 27).

14. For Each Relay: Connect one end of a #18 AWG red wire to the relay, Pin 86. Cut the lead to length, and connect the other end to the 1 amp fuse holder supplied. Use crimp on connectors supplied. Connect the other side of the 1 amp fuse holder to the A+ battery source or a vehicle A+ fuse block. Use a #18 AWG red wire and a ring lug supplied, if needed (Refer to Figure 27).
15. Check dual control operation, using the operator's manual as a test guide. In the PC programming software, make sure the "DUAL CONTROL SPEAKER" is programmed **ACTIVE HIGH**.

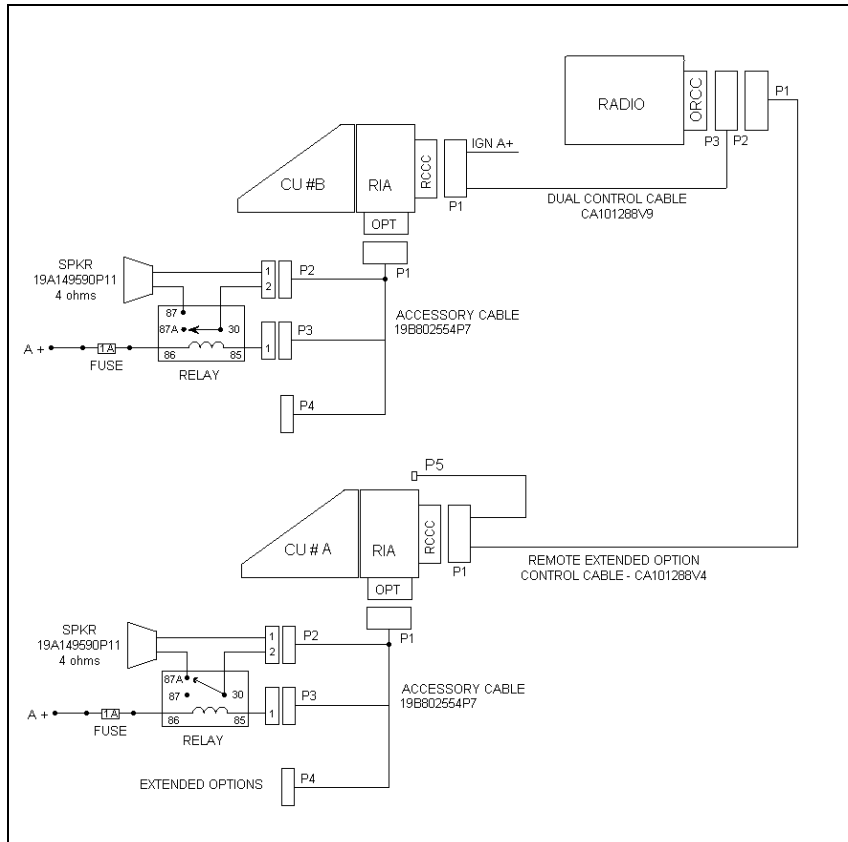

**Figure 26 – M7100<sup>IP</sup> Dual Control Unit Remote Mount/Remote Mount Installation Configuration**

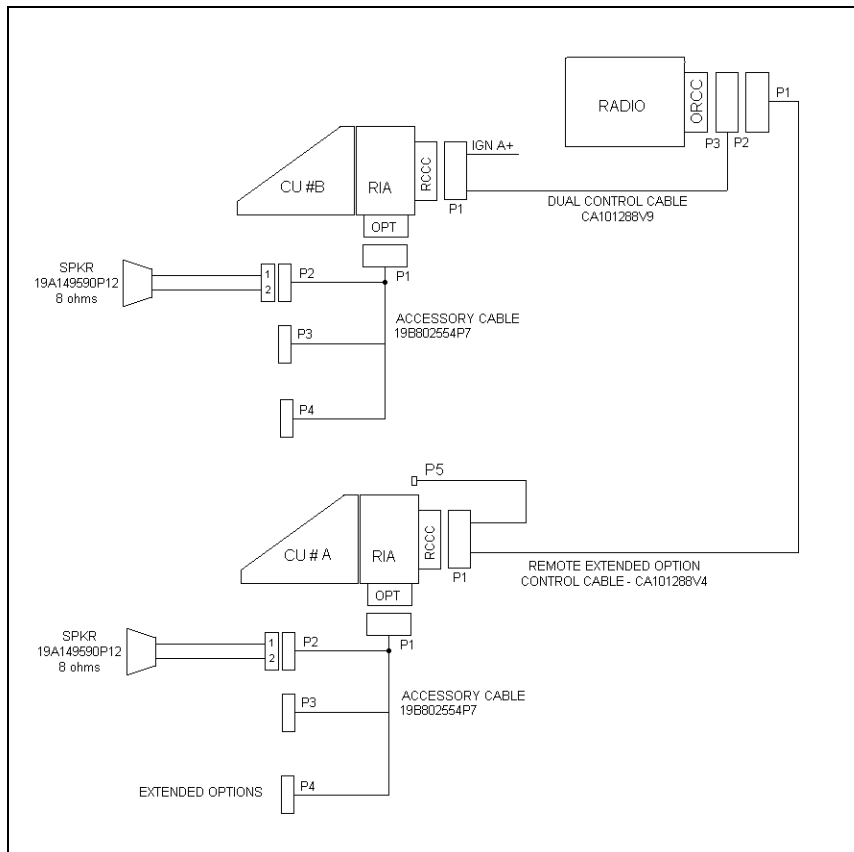

**Figure 27 – M7100<sup>IP</sup> Dual Control Unit Remote/Remote Mount Installation Configuration – Parallel Audio**

## **FIELD PROGRAMMING WITH PROGRAMMER – DUAL CONTROL UNITS**

Once installed, the M7100<sup>IP</sup> can be programmed through connector P5 on cable assemblies, CA101288V2, V4, and V10.

Please note: Keyloading and Mobile Data functions are also available through the P5 connector on the cable assemblies mentioned above. Please follow the applicable instructions in the appropriate manuals for these applications.

Perform the following procedure for each installation configuration:



### **Field Programming Procedure - Dual Control Units – Front/Remote Mount Configuration**

The Radio and Control Units must be programmed in a sequential procedure in order to provide each Control Unit with the proper identification code.

1. Configure the M7100<sup>IP</sup> Front Mount Radio and the Auxiliary Control Unit per the ProGrammer setup as shown in Figure 28, Step 1 with Control Unit A disconnected. Program the radio with the control configurations shown in Step 1 of “Pre-Installation Programming Procedure with ProGrammer – Front Mount” and adjust as necessary for the specific application.
2. Now configure the Front Mount Radio and Auxiliary Control Unit per ProGrammer setup as shown in Figure 28, Step 2 with Control Unit A reconnected. Program the configurations shown in Step 2 of “Pre-Installation Programming Procedure with ProGrammer – Front Mount” and adjust as necessary for the specific application.

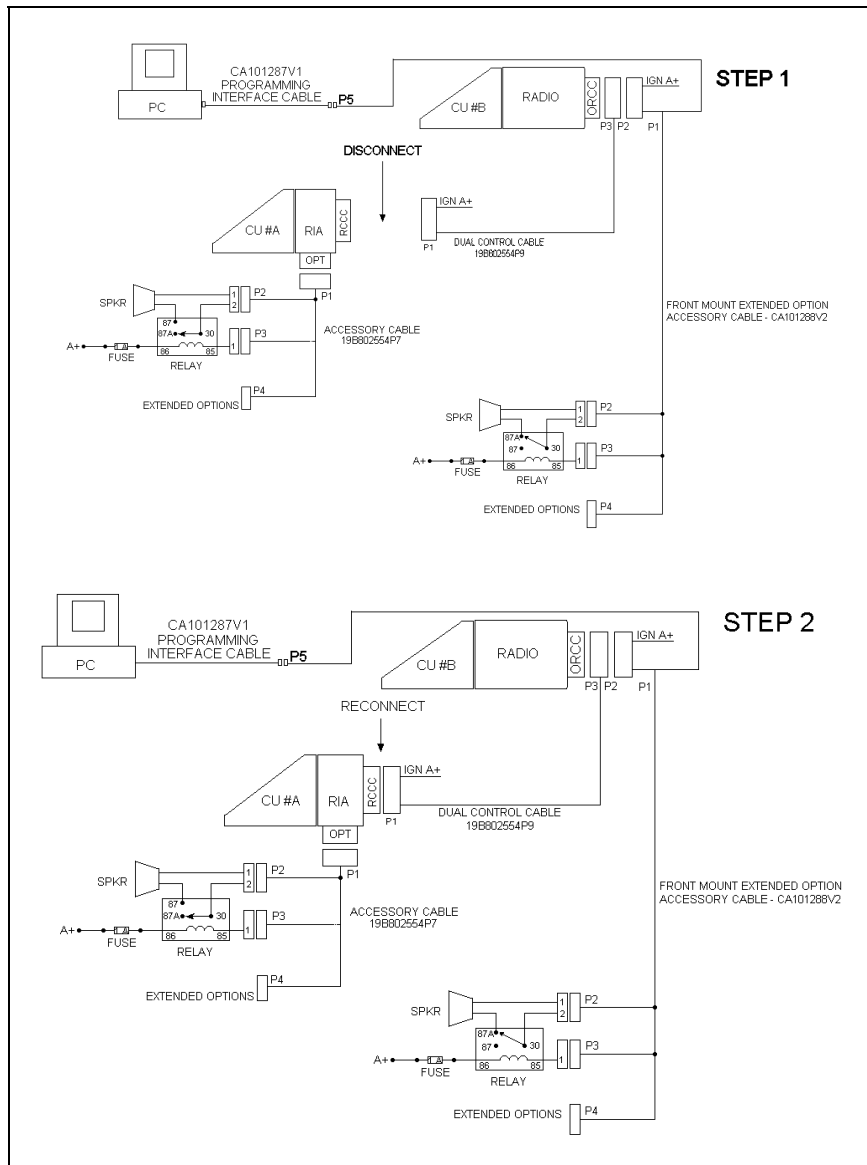
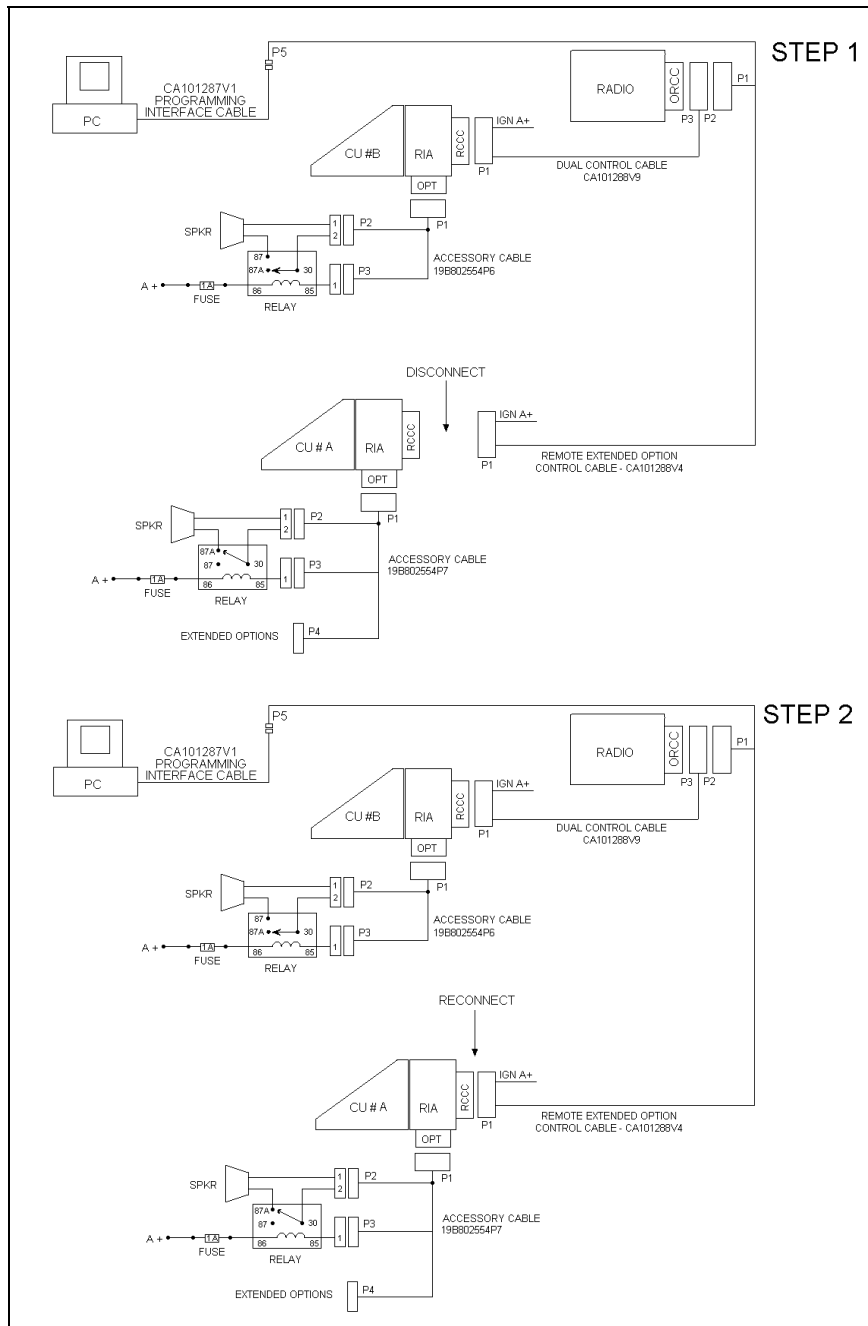

**Figure 28 – M7100<sup>IP</sup> Field Programming – Dual Control Unit Front/Remote Mount Configuration**

**Field Programming Procedure - Dual Control Units – Remote/Remote Mount Configuration**

The Radio and Control Units must be programmed in a sequential procedure in order to provide each Control Unit with the proper identification code.

1. Configure the M7100<sup>IP</sup> Remote Mount Radio per ProGrammer setup as shown in Figure 29, Step 1 with Control Unit #A disconnected. Program the radio with the control configurations shown in Step 1 of “Pre-Installation Programming Procedure with ProGrammer – Remote Mount” and adjust as necessary for the specific application.
2. Now configure the Remote Mount Radio and Auxiliary Control Unit per ProGrammer setup as shown in Figure 29, Step 2, with Control Unit #A. Program the configurations shown in Step 2 of “Pre-Installation Programming Procedure with ProGrammer – Remote Mount” and adjust as necessary for the specific application.



**Figure 29 M7100<sup>IP</sup> Field Programming – Dual Control Unit Remote/Remote Mount Configuration**

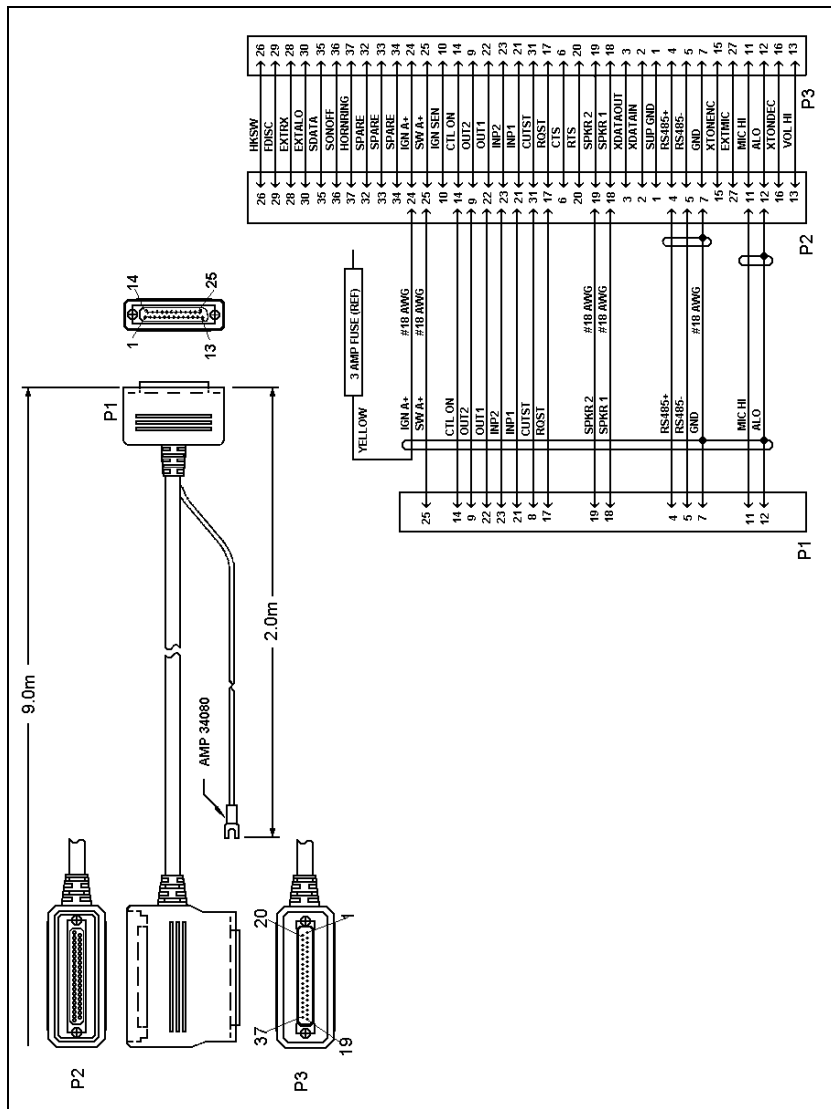

Figure 30 – Remote Mount Dual Control Cable 19B802554P9

## DUAL RADIO UNITS

The Dual Radio feature can be configured for two remote mount radio units or for one front mount unit and one remote mount unit. In remote mount configurations the Control Unit is typically located in the vehicle cab, with the Radio Units located side-by-side in vehicle trunk. In front/remote mount configurations the front mount unit is located in the vehicle cab, with the remote mount unit located in a convenient location nearby. The remote/remote mount configuration is the preferred installation, since a separate control unit is required to program the remote unit in a front/remote mount configuration.

The following Dual Radio Unit configurations are not allowed:

1. Any configuration using a DIN cassette mount.
2. Any installation where Extended Options are required from both Radio Units. Extended options are supported in one Radio Unit only.

### PRE-INSTALLATION PROGRAMMING PROCEDURE WITH PROGRAMMER – DUAL RADIO UNITS

All Radio Units in the Dual Radio configuration **MUST BE PROGRAMMED** prior to final installation. It is recommended that the units be first programmed at an Authorized Service Center, and then transferred to the user's installation.



#### NOTE

Both the M7100<sup>IP</sup> Master and M7100<sup>IP</sup> Slave mobiles must be programmed with the same Group version of Flash code. The Group version must be G30 or later. Failure to do so may result in inadvertent lockup states in the dual radio configuration.

These configurations provide for a Master Radio Unit and a Slave Radio Unit. In the remote/remote mount configuration, the Master Radio Unit is always the radio most directly connected to the Control Unit. In the front/remote mount configuration, the Master Radio Unit is always the front mount radio. Extended Options are allowed only in the Master Radio Unit. Programming each radio is straightforward, except that one radio is programmed as a Master, and one as a Slave.

1. Decide which Radio Unit will be the Master Unit. Configure the radio for programming as shown in the applicable maintenance manual.
2. Program the Master Unit (refer to the programming configuration that follows).
  - a. In the “Multi-Radio” field of ProGrammer, select “Master.”

- b. Select any M7100<sup>IP</sup> keypad programming options if the keypad is to be programmed. The M7100<sup>IP</sup> keypad options can only be programmed with “multi-radio” set to “Master” in a dual radio personality.
3. Program the unit normally. Include Extended Option features, if purchased.
4. Program the Slave Unit (refer to the programming configuration that follows).
  - a. Now configure the Slave Radio Unit for programming. Be sure to use the programming configuration for remote mount and supply the required control unit if for a front/remote mount dual radio configuration.
  - b. In the “Multi-Radio” field of ProGrammer, select “Slave.”
5. Program the unit normally. Do NOT include Extended Option features. Both radio units are now ready for vehicular installation.

**Programming Configuration**

Dual Control	Disable
Speaker	Disable
Multiple Radio	Enable
Radio Type	Slave or Master
Power Up Volume	5
Mute Time-Out	30.0
Termination	Enable
Display	Selected for Master radio only
Power Up	Enable for Master radio only
Power Up Radio	Master for Master radio only
Receive Emergency	Enable for Master radio only
Receive Only	Enable for Master radio only
MuRPS	Disable for Master radio only

**Program Radio Setup**

Mobile Options	Push Button
----------------	-------------

**M7100<sup>IP</sup> Options**

Write System Keypad File	Enable (System control unit)
Write Scan Keypad File	Enable (Scan control unit)

## **INSTALLATION INSTRUCTIONS FOR FRONT/ REMOTE MOUNT DUAL RADIO CONFIGURATION**

1. Plan the mounting locations of the two Radio Units. Note that the maximum cable length allowed between the two radios is two meters. Referring to Figure 31, run Dual Radio Cable (CA101288V10) between locations for Master and Slave Radio Units. Be sure to locate the P2/P3 connector assembly at the Master Radio Unit.
2. After installing Master Radio Unit mounting hardware, connect the Dual Radio Cable Connector (P3) to the Master Radio Unit. Tighten the two jackscrews on P3. Next, connect the Accessory Cable (CA101288V2) Connector (P1) to the Dual Radio Cable Connector (P2), and tighten to jackscrews on P2.
3. Connect the Microphone and Accessories. Refer to Accessory Installation Manual for proper connection of Accessories.
4. Connect Power Cable and Antenna, then install Master Radio Unit in mounting bracket.
5. Connect "IGN A+" lead, if option is desired. Be sure internal switch SW601 is set properly. Refer to NOTE on Page 25 of this manual for details.
6. After installing Slave Radio Unit in its mounting hardware, connect Dual Radio Cable (P1), and tighten jackscrews. Be sure SW601 setting on Slave Radio Unit is same as for Master Radio Unit. Connect Power Cable and Antenna to Slave Radio.
7. Check Dual Radio operation, using Operator's Manual as test guide.

## **INSTALLATION INSTRUCTIONS FOR REMOTE/REMOTE MOUNT DUAL RADIO CONFIGURATION**

1. Plan the mounting locations of the two Radio Units. Note that the maximum cable length allowed between the two radios is two meters. Referring to Figure 32, run Dual Radio Cable (CA101288V10) between locations for Master and Slave Radio Units. Be sure to locate the P2/P3 connector assembly at the Master Radio Unit.
2. After installing Master Radio Unit mounting hardware, connect the Dual Radio Cable Connector (P3) to the Master Radio Unit. Tighten the two jackscrews on P3.
3. Next, route the Remote Mount Extended Option Control Cable (CA101288V4) between Control Head and Master Radio locations. After installing Control Head, connect Remote Control Cable Connector (P2) to Control Head.



4. Connect "IGN A+" lead, if option is desired. Be sure internal Switch SW601 on Master Radio is set properly. Refer to Page 25 of this manual for details.
5. Connect Accessory Cable (19B802554P7) Connector (P1) to Control Head.
6. Connect the Microphone and Accessories. Refer to Accessory Installation Manual for proper connection of Accessories.
7. Now, connect Remote Control Cable Connector (P1) to the Dual Radio Cable Connector (P2), and tighten to jackscrews on P2.
8. Connect Power Cable, and Antenna, then install Master Radio Unit in mounting bracket.
9. After installing Slave Radio Unit in its mounting hardware, connect Dual Radio Cable (P1), and tighten jackscrews. Be sure SW601 setting on Slave Radio Unit is same as for Master Radio Unit. Connect Power Cable and Antenna to Slave Radio.
10. Check Dual Radio operation, using operator's manual as test guide.

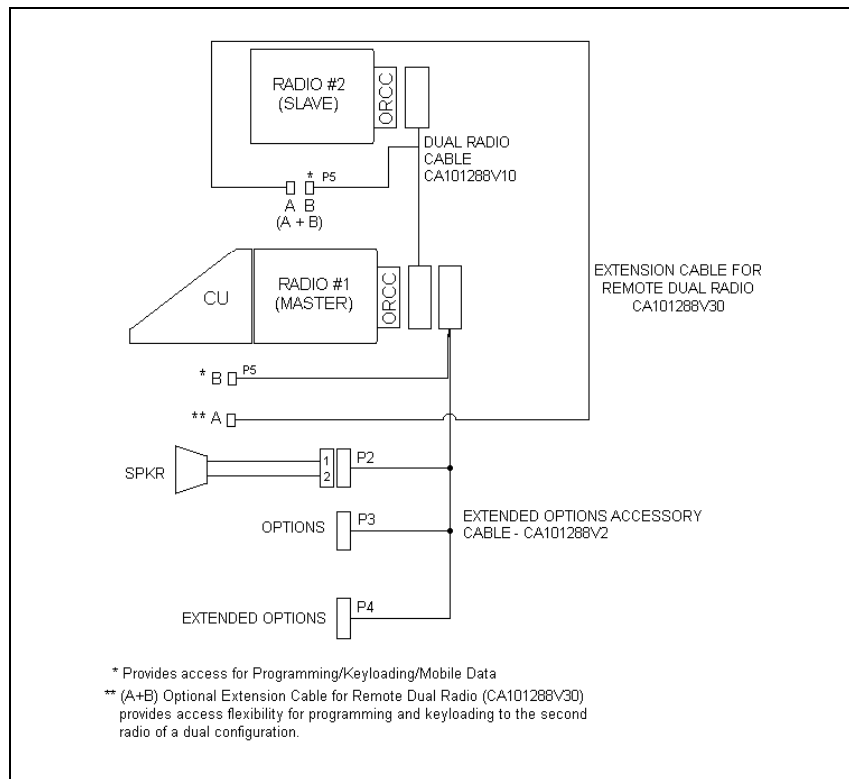

**Figure 31 - M7100<sup>IP</sup> Dual Radio Front Mount/Remote Mount Installation Configuration**

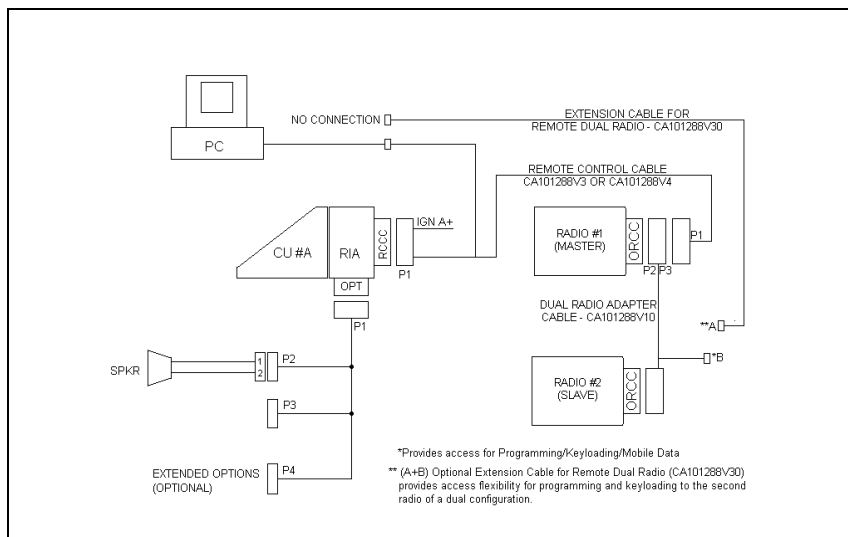

**Figure 32 - M7100<sup>IP</sup> Dual Radio Remote Mount/Remote Mount Installation Configuration**

## PROGRAMMING WITH PC PROGRAMMER – DUAL RADIO UNITS

Once installed, the M7100<sup>IP</sup> can be programmed through connector P5 on cable assemblies CA101288V2, V4, and V10. Please Note: Keyloading and Data functions are also available through the P5 connector on these cables. In addition, extended options are supported on ONE radio unit only. Follow the applicable instructions for extended option programming.

### Field Programming Procedure for Front/Remote Mount Dual Radio Configuration

The Radio and Control Units must be programmed in a sequential procedure in order to provide each Control Unit with the proper identification code.

**Step 1** Configure the M7100<sup>IP</sup> Master Radio per the ProGrammer setup shown in Figure 33, Step 1, with the Slave Radio disconnected. Program the Master Radio with the control configurations per the Pre-Installation Programming Procedure with ProGrammer – Dual Radio Units and adjust as necessary for the desired application.

**Step 2** Now configure the Slave Radio with ProGrammer as shown in Figure 33, Step 2. The Slave Radio should now be disconnected with the Slave Radio connected as shown. Program the Slave Radio with the configuration per the Pre-

Installation Programming Procedure with ProGrammer – Dual Radio Units and adjust as needed for the desired application.

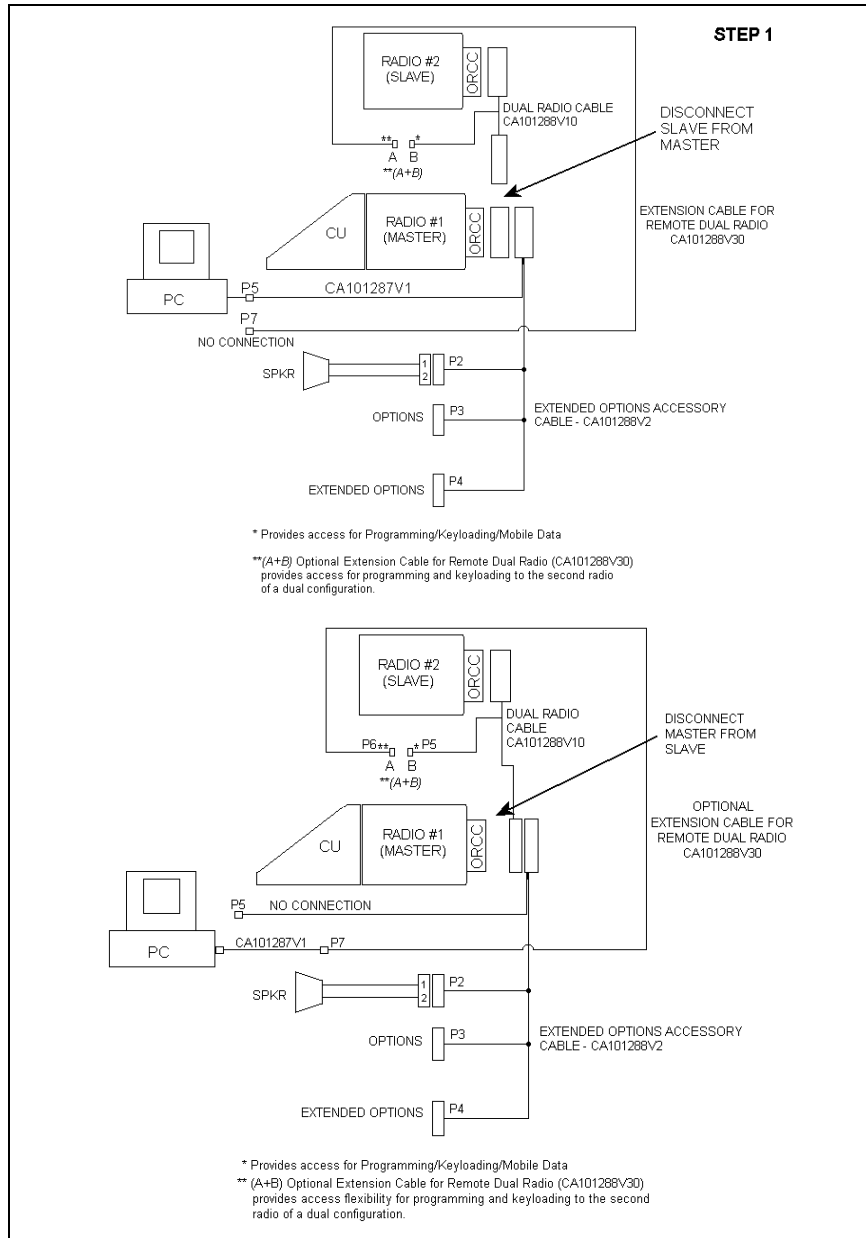

**Figure 33 – Dual Radio Configuration – Front/Remote Mount – PC Programming Procedure**

### **Field Programming Procedure for Remote/Remote Mount Dual Radio Configuration**

The Radio and Control Units must be programmed in a sequential procedure in order to provide each Control Unit with the proper identification code.

**Step 1**            Configure the M7100<sup>IP</sup> Master Radio per the ProGrammer setup as shown in Figure 34, Step 1 with the Slave Radio disconnected. Program the Master Radio with the control configurations per the Pre-Installation Programming Procedure with ProGrammer – Dual Radio Units and adjust as necessary for the desired application.

**Step 2**            Now configure the Slave Radio with ProGrammer as shown in Figure 34, Step 2. The Master Radio should now be disconnected, with the Slave Radio connected as indicated. Program the Slave Radio with the configuration per the Pre-Installation Programming Procedure with ProGrammer – Dual Radio Units and adjust as necessary for the desired application.

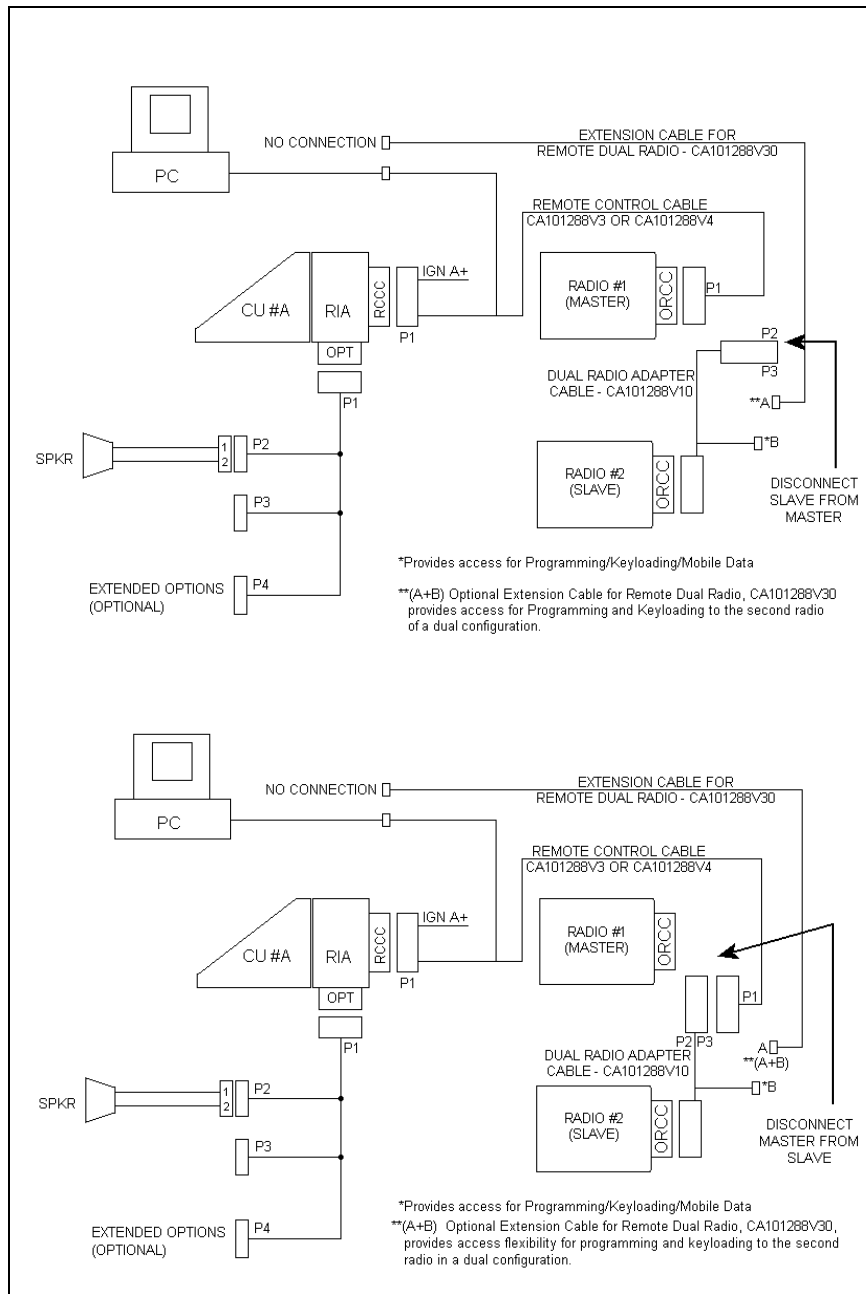

**Figure 34 – Dual Radio Configuration – Remote/Remote Mount - PC Programming Procedure**

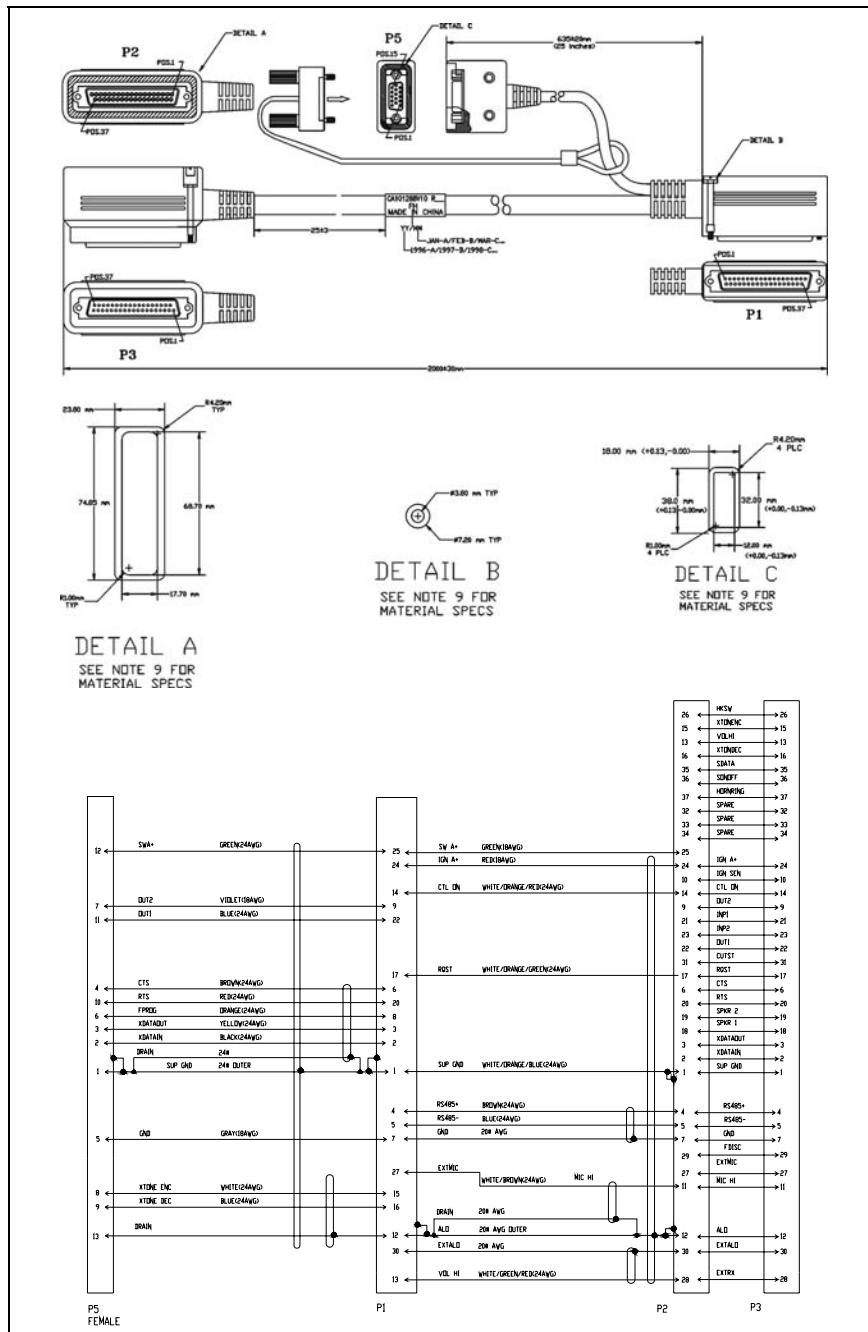

Figure 35 – Dual Radio Control Cable (CA101288V10)

## ANTENNA

Installation instructions for the antenna are packaged with the antenna. The antenna must be installed in accordance with good engineering practice for optimum results.

### Typical Mobile Antenna Installation

A permanent mount-type antenna must be located in the center of the roof.



**See the “RF ENERGY EXPOSURE INFORMATION” section at the beginning of this manual for further information regarding Maximum Permissible Exposure (MPE) limits of RF radiation absorption set by the FCC.**

Try to route the antenna cable away from locations where it will be exposed to heat, sharp edges or mechanical damage, and where it will be out of the way of the driver, passengers or vehicles mechanics. Wherever possible, existing holes in the trunk wall, and the channels above or beneath doors and window columns should be utilized.

Avoid routing the antenna cable near any electronic modules or along side any vehicle wiring.

Connect the antenna cable to the TNC on the radio, being careful not to twist the cable.

## WARRANTY

- A. M/A-COM, Inc. (hereinafter "Seller") warrants to the original purchaser for use (hereinafter "Buyer") that Equipment manufactured by or for the Seller shall be free from defects in material and workmanship, and shall conform to its published specifications. With respect to all non-M/A-COM Equipment, Seller gives no warranty, and only the warranty, if any, given by the manufacturer shall apply. Rechargeable batteries are excluded from this warranty but are warranted under a separate Rechargeable Battery Warranty (ECR-7048).
- B. Seller's obligations set forth in Paragraph C below shall apply only to failures to meet the above warranties occurring within the following periods of time from date of sale to the Buyer and are conditioned on Buyer's giving written notice to Seller within thirty (30) days of such occurrence:
1. for fuses and non-rechargeable batteries, operable on arrival only.
  2. for parts and accessories (except as noted in B.1) sold by Seller's Service Parts Operation, ninety (90) days.
  3. for PANTHER™ Series handportable and mobile radios, two (2) years.
  4. for Cougar™ Series handportable and mobile radios, two (2) years.
  5. for OpenSky®, ProVoice™, and EDACS® Equipment of Seller's manufacture, one (1) year.
- C. If any Equipment fails to meet the foregoing warranties, Seller shall correct the failure at its option (i) by repairing any defective or damaged part or parts thereof, (ii) by making available at Seller's factory any necessary repaired or replacement parts, or (iii) by replacing the failed Equipment with equivalent new or refurbished Equipment. Any repaired or replacement part furnished hereunder shall be warranted for the remainder of the warranty period of the Equipment in which it is installed. Where such failure cannot be corrected by Seller's reasonable efforts, the parties will negotiate an equitable adjustment in price. Labor to perform warranty service will be provided at no charge during the warranty period only for the Equipment covered under Paragraph B.3-B.5. To be eligible for no-charge labor, service must be performed at a M/A-COM factory (for OpenSky® Equipment only), by an Authorized Service Center (ASC) or other Servicer approved for these purposes either at its place of business during normal business hours, for mobile or personal equipment, or at the Buyer's location, for fixed location equipment. Service on fixed location equipment more than thirty (30) miles from the Service Center or other approved Servicer's place of business will include a charge for transportation.
- D. Seller's obligations under Paragraph C shall not apply to any Equipment, or part thereof, which (i) has been modified or otherwise altered other than pursuant to Seller's written instructions or written approval or, (ii) is normally consumed in operation or, (iii) has a normal life inherently shorter than the warranty periods specified in Paragraph B, or (iv) is not properly stored, installed, used, maintained or repaired, or, (v) has been subjected to any other kind of misuse or detrimental exposure, or has been involved in an accident.
- E. The preceding paragraphs set forth the exclusive remedies for claims based upon defects in or nonconformity of the Equipment, whether the claim is in contract, warranty, tort (including negligence), strict liability or otherwise, and however instituted. Upon the expiration of the warranty period, all such liability shall terminate. The foregoing warranties are exclusive and in lieu of all other warranties, whether oral, written, expressed, implied or statutory. **NO IMPLIED OR STATUTORY WARRANTIES OF MERCHANTABILITY OR FITNESS FOR PARTICULAR PURPOSE SHALL APPLY. IN NO EVENT SHALL THE SELLER BE LIABLE FOR ANY INCIDENTAL, CONSEQUENTIAL, SPECIAL, INDIRECT OR EXEMPLARY DAMAGES.**

This warranty applies only within the United States.

**M/A-COM, Inc.**  
**1011 Pawtucket Blvd.**  
Lowell, MA 01853  
1-877-OPENSKY

**M/A-COM, Inc.**  
**221 Jefferson Ridge Parkway**  
Lynchburg, VA 24501  
1-800-528-7711

ECR-7047B



## NOTES

## NOTES

## NOTES



**M/A-COM Wireless Systems**  
3315 Old Forest Road  
Lynchburg, Virginia 24501  
(Outside USA, 434-385-2400) Toll Free 800-528-7711  
[www.macom-wireless.com](http://www.macom-wireless.com)

Printed in U.S.A.