

# **Installation & Product Safety Manual**

MM102342V1  
Rev. Fp1, Sep/07



## **M7100<sup>IP</sup> Series** Mobile Radio

 **Tyco Electronics**  
Our commitment. Your advantage.

## MANUAL REVISION HISTORY

REV	DATE	SUMMARY OF CHANGES
A	Feb/04	Initial release
B	Apr/04	Add MPE and FCC information for VHF, UHF-L, UHF-H, and 800 MHz M7100 <sup>IP</sup> radio.
C	Jun/05	Added MPE and FCC information for 50W VHF mobile radio, added new remote mounting bracket for small chassis (50W TX and below) radios, and modified dual control unit graphics.
D	Jan/06	Updated field programming configuration, added DoC, CE mark, and EU Automotive Directive graphic.
E	Sep/06	Added 100W UHF MPE information and WEEE symbol and statement. Updated MPE tables by rounding distances to whole numbers safety symbols.
F	Sep/07	Added new 800 MHz antenna and updated formatting.

### SUPPLEMENTARY INFORMATION

At this time, the M7100<sup>IP</sup> mobile radio may not be operated while in a desktop station in the European Community since it does not meet immunity requirements when operated in this mode. The M7100<sup>IP</sup> mobile radio can be used in both trunked and conventional applications.

### ACKNOWLEDGEMENTS

This device is made under license under one or more of the following US patents: 4,590,473; 4,636,791; 5,148,482; 5,185,796; 5,271,017; 5,377,229; 4,716,407; 4,972,460; 5,502,767; 5,146,497; 5,164,986; 5,185,795.

The voice coding technology embodied in this product is protected by intellectual property rights including patent rights, copyrights, and trade secrets of Digital Voice Systems, Inc. The user of this technology is explicitly prohibited from attempting to decompile, reverse engineer, or disassemble the Object Code, or in any other way convert the Object Code into human-readable form.

The software contained in this device is copyrighted by M/A-COM, Inc. Unpublished rights are reserved under the copyright laws of the United States.

### CREDITS

EDACS is a registered trademark and ProGrammer, SCAT, Failsoft, ProSound, ProScan, Aegis, ProFile, ProVoice, and G-STAR are trademarks of M/A-COM, Inc.

Torx is a registered trademark of CAMCAR Division TEXTRON, Inc. POZIDRIV is a registered trademark of Phillips International Company. IMBE is a registered trademark of Digital Voice Systems, Inc. Molex is a registered trademark of Molex Incorporated. All other brand and product names are trademarks, registered trademarks, or service marks of their respective holders.

### NOTICE!



This product conforms to the European Union WEEE Directive 2002/96/EC. Do not dispose of this product in a public landfill. This product should be taken to a recycling center at the end of its life.

This manual covers M/A-COM products manufactured and sold by M/A-COM, Inc.

Repairs to this equipment should be made only by an authorized service technician or facility designated by the supplier. Any repairs, alterations, or substitution of recommended parts made by the user to this equipment not approved by the manufacturer could void the user's authority to operate the equipment in addition to the manufacturer's warranty.

This manual is published by **M/A-COM, Inc.**, without any warranty. Improvements and changes to this manual necessitated by typographical errors, inaccuracies of current information, or improvements to programs and/or equipment, may be made by **M/A-COM, Inc.**, at any time and without notice. Such changes will be incorporated into new editions of this manual. No part of this manual may be reproduced or transmitted in any form or by any means, electronic or mechanical, including photocopying and recording, for any purpose, without the express written permission of **M/A-COM, Inc.**

Automotive Directive 72/245/EEC – 95/54/EC:


e11 023101

AT	DK	FR	HU	LT	NO	SI
CY	EE	DE	IT	MT	PL	SE
CZ	FI	GR	LV	NL	SK	GB

CE 0336 !

**NOTICE**

This device is an RF transceiver intended for land mobile radio applications. The device may have use restrictions, which require that the national authority be contacted for any system licensing requirements, frequency use, allowable power level, etc.

Declaration of Conformity	
We, the undersigned,	
<b>Company</b>	M/A-COM, Inc
<b>Address, City</b>	221 Jefferson Ridge Parkway, Lynchburg, VA 24501
<b>Country</b>	United States
<b>Phone number</b>	434 455 6600
<b>Fax number</b>	434 455 6851
certify and declare under our sole responsibility that the following equipment:	
<b>Product description / Intended use</b>	PTT mobile UHF radio for trunked and conventional radio systems.
<b>EU / EFTA member states intended for use</b>	Austria, Denmark, Finland, France, Germany, Greece, Italy, Netherlands, Sweden, United Kingdom, Norway, Cyprus, Czech Republic, Estonia, Hungary, Latvia, Lithuania, Malta, Poland, Slovakia, Slovenia
<b>Member states with restrictive use</b>	
<b>Manufacturer</b>	M/A-COM, Inc.
<b>Brand</b>	M7100 <sup>®</sup>
<b>Type</b>	UHF-L (378-430 MHz) and UHF-H (450-512 MHz)
is tested to and conforms with the essential requirements for protection of health and the safety of the user and any other person and Electromagnetic Compatibility, as included in following standards:	
<b>Standard</b>	<b>Issue date</b>
EN 60950	2000
EN 301 489-1	2002-08
EN 301 489-5	2002-08
and is tested to and conforms with the essential radio test suites so that it effectively uses the frequency spectrum allocated to terrestrial/space radio communication and orbital resources so to as to avoid harmful interference, as included in following standards:	
<b>Standard</b>	<b>Issue date</b>
EN 300 086-2	2001-03
EN 300 113-2	2003-12
and therefore complies with the essential requirements and provisions of the Directive 1999/5/EC of the European Parliament and of the Council of March 9, 1999 on Radio equipment and Telecommunications Terminal Equipment and the mutual recognition of their conformity and with the provisions of Annex IV (Conformity Assessment procedure referred to in article 10).	
The following Notified Body has been consulted in the Conformity Assessment procedure:	
<b>Notified Body number</b>	<b>Name and address</b>
0336	TNO Electronic Products and Services PO Box 15, 9822 ZG Nieuwerkerk, The Netherlands
The technical documentation as required by the Conformity Assessment procedure is kept at the following address:	
<b>Company</b>	M/A-COM Eurotec
<b>Address, City</b>	Loughmahon Technology Park Skeghard Road, Blackrock, Cork
<b>Country</b>	Ireland
<b>Phone number</b>	(353) 21 4808 388
<b>Fax number</b>	(353) 21 4359 935
<b>TCF/TF reference nr.</b>	2003147TCF
<b>Drawn up in</b>	Herndon, VA
<b>Date</b>	December 1, 2005
<b>CE</b>	
<b>Name and position</b>	Daryl G. Popowitch, Regulatory Manager

## TABLE OF CONTENTS

		<i>Page</i>
<b>1</b>	<b>SAFETY SYMBOL CONVENTIONS .....</b>	<b>5</b>
<b>2</b>	<b>RF ENERGY EXPOSURE INFORMATION .....</b>	<b>6</b>
2.1	RF ENERGY EXPOSURE AWARENESS, CONTROL INFORMATION, AND OPERATION INSTRUCTIONS FOR FCC OCCUPATIONAL USE REQUIREMENTS .....	6
2.2	COMPLIANCE WITH RF EXPOSURE STANDARDS.....	7
<b>3</b>	<b>OPERATION SAFETY RECOMMENDATIONS .....</b>	<b>10</b>
3.1	TRANSMITTER HAZARDS .....	10
3.2	SAFE DRIVING RECOMMENDATIONS .....	11
<b>4</b>	<b>MARITIME CHANNELS.....</b>	<b>12</b>
<b>5</b>	<b>OPERATING RULES AND REGULATIONS .....</b>	<b>13</b>
5.1	OPERATING TIPS .....	14
<b>6</b>	<b>INTRODUCTION.....</b>	<b>15</b>
<b>7</b>	<b>UNPACKING AND CHECKING EQUIPMENT .....</b>	<b>16</b>
<b>8</b>	<b>PLANNING THE INSTALLATION.....</b>	<b>21</b>
<b>9</b>	<b>EQUIPMENT REQUIRED.....</b>	<b>23</b>
<b>10</b>	<b>INSTALLATION.....</b>	<b>24</b>
10.1	RUNNING CABLES .....	24
10.2	CONTROL UNIT MOUNTING .....	32
10.3	PIGTAIL BRACKET.....	32
10.4	SPEAKER.....	35
10.5	MICROPHONE HANGER AND/OR HOOKSWITCH MOUNTING .....	36
10.6	SIREN AND LIGHT.....	36
10.7	RADIO MOUNTING AND FINAL HOOK-UP.....	37
<b>11</b>	<b>DUAL CONTROL UNIT INSTALLATION .....</b>	<b>42</b>
11.1	PROGRAMMING PROCEDURE - FRONT MOUNT CONFIGURATION .....	43
11.2	PROGRAMMING PROCEDURE - REMOTE MOUNT CONFIGURATION .....	46
11.3	INSTALLATION INSTRUCTIONS FOR FRONT MOUNT DUAL CONTROL UNITS .....	50
11.4	INSTALLATION INSTRUCTIONS FOR REMOTE MOUNT DUAL CONTROL UNITS .....	54
<b>12</b>	<b>DUAL RADIO UNITS.....</b>	<b>58</b>
12.1	PRE-INSTALLATION PROGRAMMING PROCEDURE – DUAL RADIO UNITS .....	58
12.2	INSTALLATION INSTRUCTIONS FOR FRONT/REMOTE MOUNT DUAL RADIO CONFIGURATION .....	60
12.3	INSTALLATION INSTRUCTIONS REMOTE/REMOTE MOUNT DUAL RADIO CONFIGURATION .....	62
12.4	FIELD PROGRAMMING – DUAL RADIO UNITS .....	63
12.5	ANTENNA .....	68
<b>13</b>	<b>WARRANTY .....</b>	<b>69</b>

# 1 SAFETY SYMBOL CONVENTIONS

The following conventions are used to alert the user to general safety precautions that must be observed during all phases of operation, service, and repair of this product. Failure to comply with these precautions or with specific warnings elsewhere violates safety standards of design, manufacture, and intended use of the product. M/A-COM, Inc. assumes no liability for the customer's failure to comply with these standards.



The **WARNING** symbol calls attention to a procedure, practice, or the like, which, if not correctly performed or adhered to, could result in personal injury. Do not proceed beyond a **WARNING** symbol until the conditions identified are fully understood or met.



The **CAUTION** symbol calls attention to an operating procedure, practice, or the like, which, if not performed correctly or adhered to, could result in a risk of danger, damage to the equipment, or severely degrade the equipment performance.



The **NOTE** symbol calls attention to supplemental information, which may improve system performance or clarify a process or procedure.



The **ESD** symbol calls attention to procedures, practices, or the like, which could expose equipment to the effects of **E**lectro-**S**tatic **D**ischarge. Proper precautions must be taken to prevent ESD when handling circuit modules.



**WARNING** - The electrical hazard symbol indicates there is an electrical hazard present.

## 2 RF ENERGY EXPOSURE INFORMATION

### 2.1 RF ENERGY EXPOSURE AWARENESS, CONTROL INFORMATION, AND OPERATION INSTRUCTIONS FOR FCC OCCUPATIONAL USE REQUIREMENTS

**BEFORE USING YOUR MOBILE TWO-WAY RADIO, READ THIS IMPORTANT RF ENERGY AWARENESS AND CONTROL INFORMATION AND OPERATIONAL INSTRUCTIONS TO ENSURE COMPLIANCE WITH THE FCC'S RF EXPOSURE GUIDELINES.**

**NOTICE:** This radio is intended for use in occupational/controlled conditions, where users have full knowledge of their exposure and can exercise control over their exposure to meet FCC limits. This radio device is **NOT** authorized for general population, consumer, or any other use.



**CAUTION**

Changes or modifications not expressly approved by M/A-COM, Inc. could void the user's authority to operate the equipment.

This two-way radio uses electromagnetic energy in the radio frequency (RF) spectrum to provide communications between two or more users over a distance. It uses RF energy or radio waves to send and receive calls. RF energy is one form of electromagnetic energy. Other forms include, but are not limited to, electric power, sunlight, and x-rays. RF energy, however, should not be confused with these other forms of electromagnetic energy, which, when used improperly, can cause biological damage. Very high levels of x-rays, for example, can damage tissues and genetic material.

Experts in science, engineering, medicine, health, and industry work with organizations to develop standards for exposure to RF energy. These standards provide recommended levels of RF exposure for both workers and the general public. These recommended RF exposure levels include substantial margins of protection. All two-way radios marketed in North America are designed, manufactured, and tested to ensure they meet government established RF exposure levels. In addition, manufacturers also recommend specific operating instructions to users of two-way radios. These instructions are important because they inform users about RF energy exposure and provide simple procedures on how to control it. Please refer to the following websites for more information on what RF energy exposure is and how to control your exposure to assure compliance with established RF exposure limits.

<http://www.fcc.gov/oet/rfsafety/rf-faqs.html>

<http://www.osha.gov/SLTC/radiofrequencyradiation/index.html>

### **2.1.1 Federal Communications Commission Regulations**

Your M/A-COM, Inc. M7100<sup>IP</sup> mobile two-way radio is designed and tested to comply with the FCC RF energy exposure limits for mobile two-way radios before it can be marketed in the United States. When two-way radios are used as a consequence of employment, the FCC requires users to be fully aware of and able to control their exposure to meet occupational requirements. Exposure awareness can be facilitated by the use of a label directing users to specific user awareness information. Your M/A-COM, Inc. M7100<sup>IP</sup> two-way radio has an RF exposure product label. Also, your M7100<sup>IP</sup> Installation and Operator's Manuals (operator's manual MM102341V1 is available at [www.macom-wireless.com](http://www.macom-wireless.com)) include information and operating instructions required to control your RF exposure and to satisfy compliance requirements.

## **2.2 COMPLIANCE WITH RF EXPOSURE STANDARDS**

Your M/A-COM, Inc. M7100<sup>IP</sup> mobile two-way radio is designed and tested to comply with a number of national and international standards and guidelines (listed below) regarding human exposure to RF electromagnetic energy. This radio complies with the IEEE and ICNIRP exposure limits for occupational/controlled RF exposure environment at duty factors of up to 50% talk-50% listen and is authorized by the FCC for occupational use. In terms of measuring RF energy for compliance with the FCC exposure guidelines, your radio antenna radiates measurable RF energy only while it is transmitting (talking), not when it is receiving (listening) or in standby mode.

Your M/A-COM, Inc. M7100<sup>IP</sup> mobile two-way radio complies with the following RF energy exposure standards and guidelines:

- United States Federal Communications Commission (FCC), Code of Federal Regulations; 47 CFR §§ 2 sub-part J.
- American National Standards Institute (ANSI)/Institute of Electrical and Electronic Engineers (IEEE) C95.1-1992.
- Institute of Electrical and Electronic Engineers (IEEE) C95.1-1999.



Table 2-1 lists the recommended minimum lateral distance for a controlled environment and for unaware bystanders in an uncontrolled environment, from transmitting types of antennas (i.e., monopoles over a ground plane, or dipoles) at rated radio power for mobile radios installed in a vehicle. Transmit only when unaware bystanders are at least the uncontrolled recommended minimum lateral distance away from the transmitting antenna.

**Table 2-1: Rated Power and Recommended Minimum Lateral Distance**

MOBILE RADIO FREQUENCY SPLIT	RATED POWER OF VEHICLE-INSTALLED MOBILE TWO-WAY RADIO	RECOMMENDED MINIMUM LATERAL DISTANCE FROM TRANSMITTING ANTENNA	
		CONTROLLED	UNCONTROLLED
VHF	110 Watts (Antenna P/N: 19B209568P6)	93 cm	208 cm
VHF	50 Watts (Antenna P/N: AN102800V1/V2)	64 cm	142 cm
UHF-L 378-430 MHz	50 Watts (Antenna P/N: AN102800V1)	58 cm	130 cm
UHF-H 450-512 MHz	50 Watts (Antenna P/N: AN102800V1)	47 cm	104 cm
UHF-H 450-470 MHz	100 Watts (Antenna P/N: AN102800V1, AN-025158-001, AN-025158-005, AN-025158-009, AN-025158-011)	72 cm	162 cm
800 MHz	35 Watts (Antenna P/N: AN102800V1)	33 cm	73 cm
800 MHz	35 Watts (Antenna P/N AN-025167-015)	38 cm	85 cm



## 2.2.1 Mobile Antennas



NOTE

This device must not be co-located or operated in conjunction with any other antenna or transmitter.

Install the radio's antenna (refer to Table 2-1 for applicable antenna part numbers) in the center of the vehicle's roof. These mobile antenna installation guidelines are limited to metal body motor vehicles or vehicles with appropriate ground planes. The antenna installation should additionally be in accordance with the following:

- The requirements of the antenna manufacturer/supplier included with the antenna.
- Instructions in the M7100<sup>IP</sup> Radio Installation Manual, including minimum antenna cable lengths.
- The installation manual providing specific information of how to install the antennas to facilitate recommended operating distances to all potentially exposed persons.

Use only the M/A-COM approved/supplied antenna(s) or approved replacement antenna. Unauthorized antennas, modifications, or attachments could damage the radio and may violate FCC regulations.

## 2.2.2 Approved Accessories

This radio has been tested and meets the FCC RF guidelines when used with the M/A-COM accessories supplied or designated for use with this product. Use of other accessories may not ensure compliance with the FCC's RF exposure guidelines, and may violate FCC regulations.

For a list of M/A-COM approved accessories refer to the product manuals, M/A-COM's Products and Services Catalog, or contact M/A-COM at 1-800-528-7711.

## 2.2.3 Contact Information

For additional information on exposure requirements or other information, contact M/A-COM, Inc. at 1-800-528-7711 or at <http://www.macom-wireless.com>.

## 3 OPERATION SAFETY RECOMMENDATIONS

### 3.1 TRANSMITTER HAZARDS



The operator of any mobile radio should be aware of certain hazards common to the operation of vehicular radio transmitters. A list of several possible hazards is given.

- **Explosive Atmospheres** – Just as it is dangerous to fuel a vehicle with the motor running, similar hazards exist when operating a mobile radio. Be sure to turn the radio off while fueling a vehicle. Do not carry containers of fuel in the trunk of a vehicle if the radio is mounted in the trunk.

**Areas with potentially explosive atmosphere are often, but not always, clearly marked. Turn OFF your radio when in any area with a potentially explosive atmosphere. It is rare, but not impossible that the radio or its accessories could generate sparks.**

- **Interference to Vehicular Electronics Systems** – Electronic fuel injection systems, electronic anti-skid braking systems, electronic cruise control systems, etc., are typical electronic systems that can malfunction due to the lack of protection from radio frequency energy present when transmitting. If the vehicle contains such equipment, consult the dealer and enlist their aid in determining the expected performance of electronic circuits when the radio is transmitting.
- **Electric Blasting Caps** – To prevent accidental detonation of electric blasting caps, **DO NOT** use two-way radios within 1000 feet of blasting operations. Always obey the “**Turn Off Two-Way Radios**” signs posted where electric blasting caps are being used. (OSHA Standard: 1926-900)
- **Liquefied Petroleum (LP) Gas Powered Vehicles** – Mobile radio installations in vehicles powered by liquefied petroleum gas with the LP gas container in the trunk or other sealed-off space within the interior of the vehicle must conform to the National Fire Protection Association standard **NFPA 58** requiring:
  - The space containing the radio equipment shall be isolated by a seal from the space containing the LP gas container and its fittings.
  - Outside filling connections shall be used for the LP gas container.
  - The LP gas container shall be vented to the outside of the vehicle.

## **3.2 SAFE DRIVING RECOMMENDATIONS**

(Recommended by AAA)

- Read the literature on the safe operation of the radio.
- Keep both hands on the steering wheel and the microphone in its hanger whenever the vehicle is in motion.
- Place calls only when the vehicle is stopped.
- When talking from a moving vehicle is unavoidable, drive in the slower lane. Keep conversations brief.
- If a conversation requires taking notes or complex thought, stop the vehicle in a safe place and continue the call.
- Whenever using a mobile radio, exercise caution.

## 4 MARITIME CHANNELS

As part of FCC Equipment Authorization Part 80 licensing, a maritime frequency usage plan has been included in this manual for reference.

CHANNEL NUMBER			FREQUENCY (MHZ)	
USA	INT	CAN	TX	RX
	01	01	156.050	160.650
01a			156.050	156.050
	02	02	156.100	160.700
	03	03	156.150	160.750
03a			156.150	156.150
	04		156.200	160.800
		04a	156.200	156.200
	05		156.250	160.850
05a		05a	156.250	156.250
06	06	06	156.300	156.300
	07		156.350	160.950
07a		07a	156.350	156.350
08	08	08	156.400	156.400
09	09	09	156.450	156.450
10	10	10	156.500	156.500
11	11	11	156.550	156.550
12	12	12	156.600	156.600
13	13	13	156.650	156.650
14	14	14	156.700	156.700
15	15	15	156.750	156.750
16	16	16	156.800	156.800
17	17	17	156.850	156.850
	18		156.900	161.500
18a		18a	156.900	156.900
	19		156.950	161.550
19a		19a	156.950	156.950
20	20	20	157.000	161.600
20a			157.000	157.000
	21	21	157.050	157.050
		21	RX only	161.650
	22		157.100	161.700
22a		22a	157.100	157.100
	23	23	157.150	161.750
23a			157.150	157.150
24	24	24	157.200	161.800
25	25	25	157.250	161.850
		25	RX only	161.850
26	26	26	157.300	161.900
27	27	27	157.350	161.950
28	28	28	157.400	162.000
		28	Rx only	162.000
	60	60	156.025	160.625
	61		156.075	160.675
61a		61a	156.075	156.075
	62		156.125	160.725
		62a	156.125	156.125
	63		156.175	160.775
63a			156.175	156.175
	64	64	156.225	160.825
64a		64a	156.225	160.825
	65		156.275	160.875
65a	65a	65a	156.275	156.275

CHANNEL NUMBER			FREQUENCY (MHZ)	
USA	INT	CAN	TX	RX
	66		156.325	160.925
66a	66a	66a	156.325	156.325
67	67	67	156.375	156.375
68	68	68	156.425	156.425
69	69	69	156.475	156.475
70	70	70	156.525	156.525
71	71	71	156.575	156.575
72	72	72	156.625	156.625
73	73	73	156.675	156.675
74	74	74	156.725	156.725
75	75	75	156.775	156.775
76	76	76	156.825	156.825
77	77	77	156.875	156.875
	78		156.925	161.525
78a		78a	156.925	156.925
	79		156.975	161.575
79a		79a	156.975	156.975
	80		157.025	161.625
80a		80a	157.025	157.025
	81		157.075	161.675
81a		81a	157.075	157.075
	82		157.125	161.725
82a		82a	157.125	157.125
	83	83	157.175	161.775
83a		83a	157.175	157.175
		83	RX only	161.775
84	84	84	157.225	161.825
84a			157.225	157.225
85	85	85	157.275	161.875
85a			157.275	157.275
86	86	86	157.325	161.925
86a			157.325	157.325
88	88	88	157.425	162.025
88a			157.425	157.425

WX CHANNEL	FREQUENCY (MHZ)	
	TX	RX
1	RX only	162.550
2	RX only	162.400
3	RX only	162.475
4	RX only	162.425
5	RX only	162.450
6	RX only	162.500
7	RX only	162.525
8	RX only	161.650
9	RX only	161.775
10	RX only	163.275

NOTE: Channels 02, 04, 60, and 62 are not available in the U.S.

NOTE: The letter "a" following the channel designator indicates simplex operation on a channel designated internationally as a duplex channel.

## 5 OPERATING RULES AND REGULATIONS

Two-way FM radio systems must be operated in accordance with the rules and regulations of the local, regional, or national government.

In the United States, the M7100<sup>IP</sup> Series mobile radio must be operated in accordance with the rules and regulations of the Federal Communications Commission (FCC). As an operator of two-way radio equipment, you must be thoroughly familiar with the rules that apply to your particular type of radio operation. Following these rules helps eliminate confusion, assures the most efficient use of the existing radio channels, and results in a smoothly functioning radio network.

When using your two-way radio, remember these rules:

- It is a violation of FCC rules to interrupt any distress or emergency message. As your radio operates in much the same way as a telephone “**party line**,” always listen to make sure that the channel is clear before transmitting. Emergency calls have priority over all other messages. If someone is sending an emergency message – such as reporting a fire or asking for help in an accident – **KEEP OFF THE AIR!**
- The use of profane or obscene language is prohibited by Federal law.
- It is against the law to send false call letters or false distress or emergency messages. The FCC requires that you keep conversations brief and confine them to business. To save time, use coded messages whenever possible.
- Using your radio to send personal messages (except in an emergency) is a violation of FCC rules. You may send only those messages that are essential for the operation of your business.
- It is against Federal law to repeat or otherwise make known anything you overhear on your radio. Conversations between others sharing your channel must be regarded as confidential.
- The FCC requires that you identify yourself at certain specific times by means of your call letters. Refer to the rules that apply to your particular type of operation for the proper procedure.
- No changes or adjustments shall be made to the equipment except by an authorized or certified electronics technician.



NOTE

**Under U.S. law, operation of an unlicensed radio transmitter within the jurisdiction of the United States may be punishable by a fine of up to \$10,000, imprisonment for up to two (2) years, or both.**

## **5.1 OPERATING TIPS**

The following conditions tend to reduce the effective range of two-way radios and should be avoided whenever possible:

- Operating the radio in areas of low terrain, or while under power lines or bridges
- Obstructions such as mountains and buildings
- In areas where transmission or reception is poor, some improvement can be obtained by moving a few yards in another direction or moving to a higher elevation.

## 6 INTRODUCTION

This manual contains installation instructions for the M7100<sup>IP</sup> Series Mobile Radio Unit and associated accessories. These instructions cover the mounting and cabling of the radio; interconnection and wiring diagrams are provided for reference.

The radio should be programmed prior to installation. Refer to the Software Release Notes with TQS3385 or TQS3389 for equipment and compatibility requirements.

Shop Programming Cable	TQ3409 (CA101288V15)
Field Programming Cable	TQ3410 (CA101287V1)
ProGrammer™ Software	TQS3385
	or
Conventional ProGrammer Software	TQS3389

## 7 UNPACKING AND CHECKING EQUIPMENT

Carefully unpack the radio and identify each item in the shipping container (some items that typically ship are listed below). If damage has occurred to the equipment during shipment, file a claim with the carrier immediately. Refer to Table 7-1 and Table 7-2 in this manual or to M/A-COM's Products and Services catalog for options and accessories for the M7100<sup>IP</sup> Series Mobile Radio.

- M7100<sup>IP</sup> Series Mobile Radio Unit
- Control Unit
- Microphone
- Speaker
- Power Cable
- Control Cable
- Front Mount Bracket Kit  
or
- Remote Mount Bracket Kit  
with
- Control Unit Mount Kit
- Quick Guide (MM102344V1)
- Installation & Product Safety Manual (MM102342V1)



Figure 7-1 – M7100<sup>IP</sup> Series Mobile Radio Components





**Figure 7-2: Rear Angle View of Radio (110W VHF Shown)**



**Figure 7-3: – Interface Cables**



**Figure 7-4: Option Cables**

**Table 7-1: M7100<sup>IP</sup> Option and Accessory Kits (60W TX and Above)**

OPTION	DESCRIPTION
<b>ANTENNAS</b>	
19B209568P6	Antenna, 136-174 MHz, ¼ Wave, TNC, Roof Mount
MAHG-AN3G	Antenna, 136-870 MHz, ¼ Wave, TNC, Roof Mount
MAHG-AN3R	Antenna, 136-941 MHz, ¼ Wave, TNC, Thick Roof Mount
AN-025158-001	Antenna, 450-470 MHz
AN-025158-005	Antenna, 450-470 MHz
AN-025158-009	Antenna, 450-470 MHz
AN-025158-011	Antenna, 450-470 MHz
<b>REMOTE MOUNT ACCESSORIES (60W AND ↑)</b>	
MAHG-ZN5Y	Includes remote mount radio front cover, front cover logo label, remote mount accessory cable, remote mount control cable, 7.5M power cable, microphone hanger kit, remote mount radio mounting kit, control unit mounting kit, DB15-HD connector to control unit mounting kit, and mobile speaker.
<b>HAND HELD CONTROLLER (WITH SIREN) ACCESSORIES, REMOTE MOUNT (60W AND ↑)</b>	
MAHG-ZN6C	Includes Hand Held Controller (HHC) with mounting bracket, HHC interface cable (with siren interface), remote radio front cover, front cover logo label, remote mount accessory cable, remote mount control cable, 7.5M power cable, remote mount radio mounting kit, mobile speaker, and HHC operator and installation manuals.
<b>HAND HELD CONTROLLER (WITHOUT SIREN) ACCESSORIES, REMOTE MOUNT (60W AND ↑)</b>	
MAHG-ZN6A	Includes Hand Held Controller (HHC) with mounting bracket, HHC interface cable, remote radio front cover, front cover logo label, remote mount accessory cable, remote mount control cable, 7.5M power cable, remote mount radio mounting kit, mobile speaker, and HHC operator and installation manuals.
<b>DUAL CONTROL, SCAN CONTROL UNIT, LONG PACKAGE</b>	
MAHG-ZN6J	Includes scan control unit, control unit logo label, dual control cable (9M), accessory cable, control unit mounting kit, microphone hanger kit, relay kits (qty 2), mobile speaker, connector support bracket, and M7100 <sup>IP</sup> operator's manual.
<b>DUAL CONTROL, SYSTEM CONTROL UNIT, LONG PACKAGE</b>	
MAHG-ZN6K	Includes system control unit, system control unit keycap kit, control unit logo label, dual control cable (9M), accessory cable, control unit mounting kit, microphone hanger kit, relay kits (qty 2), mobile speaker, connector support bracket, and M7100 <sup>IP</sup> operator's manual.
<b>DUAL CONTROL, HHC (WITH SIREN), LONG PACKAGE</b>	
MAHG-ZN6M	Includes HHC with mounting bracket, HHC interface cable (with Siren interface), dual control cable (9M), accessory cable, relay kits (qty 2), mobile speaker, connector support bracket, and HHC installation and operator's manuals.
<b>DUAL CONTROL, HHC (WITHOUT SIREN), LONG PACKAGE</b>	
MAHG-ZN6L	Includes HHC with mounting bracket, HHC interface cable, dual control cable (9M), accessory cable, relay kits (qty 2), mobile speaker, connector support bracket, and HHC installation and operator's manuals.
<b>DUAL RADIO, HHC (WITHOUT SIREN), LONG PACKAGE</b>	
MAHG-ZN6P	Includes dual radio cable, programming extension cable, 7.5M power cable, remote radio front cover, front cover logo label, remote mount radio mounting kit, connector support bracket, DB15-HD connector to control unit mounting kit, and DB15-HD connector to radio mounting kit.

Refer to M/A-COM's Products and Services Catalog for the full line of options and accessories available for use with the M7100 mobile radio.

**Table 7-2: M7100<sup>IP</sup> Option and Accessory Kits (50W TX and Below)**

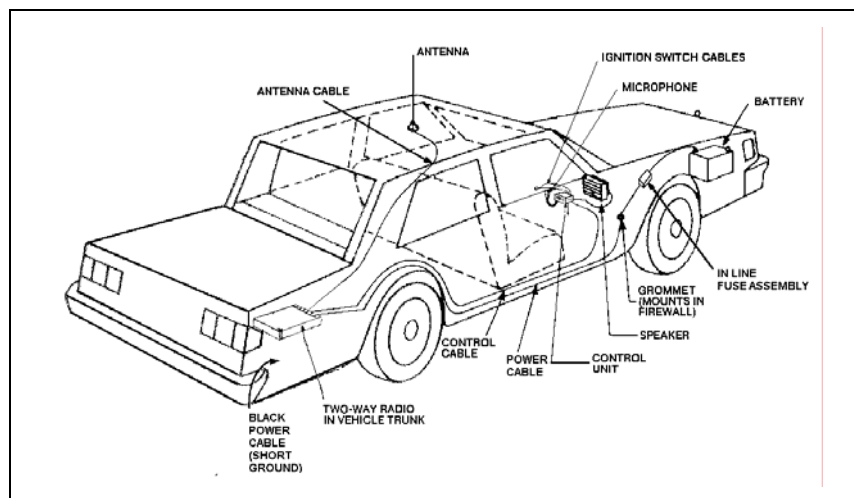
<b>OPTION</b>	<b>DESCRIPTION</b>
<b>ANTENNAS</b>	
MAHG-AN3G	Antenna, 136-870 MHz, ¼ Wave, TNC, Roof Mount
MAHG-AN3R	Antenna, 136-941 MHz, ¼ Wave, TNC, Thick Roof Mount
AN-025167-015	Antenna, 700/800 MHz, 5 dB Gain, Combined GPS, Roof Mount
<b>FRONT MOUNT ACCESSORIES (50W AND ↓)</b>	
MAHG-ZN5W	Includes front mount accessory cable assembly, 7.5M power cable, microphone hanger kit, front mount radio mounting kit, DB15-HD connector to radio mounting bracket kit, and mobile speaker.
<b>REMOTE MOUNT ACCESSORIES (50W AND ↓)</b>	
MAHG-ZN5X	Includes remote mount radio front cover, front cover logo label, remote mount accessory cable, remote mount control cable, 7.5M power cable, microphone hanger kit, remote mount radio mounting kit, control unit mounting kit, DB15-HD connector to control unit mounting kit, and mobile speaker.
<b>HAND HELD CONTROLLER (WITH SIREN) ACCESSORIES, REMOTE MOUNT (50W AND ↓)</b>	
MAHG-ZN6B	Includes Hand Held Controller (HHC) with mounting bracket, HHC interface cable (with siren interface), remote radio front cover, front cover logo label, remote mount accessory cable, remote mount control cable, 7.5M power cable, remote mount radio mounting kit, mobile speaker, and HHC operator and installation manuals.
<b>HAND HELD CONTROLLER (WITHOUT SIREN) ACCESSORIES, REMOTE MOUNT (50W AND ↓)</b>	
MAHG-ZN5Z	Includes Hand Held Controller (HHC) with mounting bracket, HHC interface cable, remote radio front cover, front cover logo label, remote mount accessory cable, remote mount control cable, 7.5M power cable, remote mount radio mounting kit, mobile speaker, and HHC operator and installation manuals.
<b>DUAL CONTROL, SCAN CONTROL UNIT, SHORT PACKAGE</b>	
MAHG-ZN6S	Includes scan control unit, control unit logo label, dual control cable (9M), accessory cable, control unit mounting kit, microphone hanger kit, relay kits (qty 2), mobile speaker, connector support bracket, and M7100 <sup>IP</sup> operator's manual.
<b>DUAL CONTROL, SYSTEM CONTROL UNIT, SHORT PACKAGE</b>	
MAHG-ZN6T	Includes system control unit, system control unit keycap kit, control unit logo label, dual control cable (9M), accessory cable, control unit mounting kit, microphone hanger kit, relay kits (qty 2), mobile speaker, connector support bracket, and M7100 <sup>IP</sup> operator's manual.
<b>DUAL CONTROL, HHC (WITH SIREN), SHORT PACKAGE</b>	
MAHG-ZN6V	Includes HHC with mounting bracket, HHC interface cable (with Siren interface), dual control cable (9M), accessory cable, relay kits (qty 2), mobile speaker, connector support bracket, and HHC installation and operator's manuals.
<b>DUAL CONTROL, HHC (WITHOUT SIREN), SHORT PACKAGE</b>	
MAHG-ZN6U	Includes HHC with mounting bracket, HHC interface cable, dual control cable (9M), accessory cable, relay kits (qty 2), mobile speaker, connector support bracket, and HHC installation and operator's manuals.
<b>DUAL RADIO, HHC (WITHOUT SIREN), SHORT PACKAGE</b>	
MAHG-ZN6N	Includes dual radio cable, programming extension cable, 7.5M power cable, remote radio front cover, front cover logo label, remote mount radio mounting kit, connector support bracket, DB15-HD connector to control unit mounting kit, and DB15-HD connector to radio mounting kit.

Refer to M/A-COM's Products and Services Catalog for the full line of options and accessories available for use with the M7100 mobile radio.

## 8 PLANNING THE INSTALLATION

Figure 8-1 illustrates a typical single remote mount mobile radio installation. Instructions for dual control unit and dual radio unit installations are provided in Sections 11 and 12. Before starting any radio installation, plan the location and positioning carefully so that it will be:

- Safe for the operator and passengers,
- Away from airbag deployment area,
- Convenient for the operator to use,
- Neat,
- Protected from water damage,
- Easy to service,
- Out of the way of auto mechanics
- Out of the way of passengers.



**Figure 8-1: Typical Installation (Remote Mount Shown)**

It is suggested that the radio be installed by one of the many M/A-COM Authorized Service Centers located throughout the United States. Their experienced service personnel can provide a proper radio installation and make any final adjustments that may be needed.



**Vehicular Electronics** - Electronic fuel injection systems, electronic anti-skid braking systems, air bags, electronic cruise control systems, etc., are typical of the types of electronic devices which might be prone to malfunction due to the lack of protection from radio frequency energy present when a radio is transmitting. If the vehicle contains such equipment, consult the dealer to determine if such electronic equipment will perform normally when the radio is transmitting.



**Air Bags** – For driver and passenger safety, avoid mounting the radio above or near airbag deployment areas. Note that vehicles might contain front driver and passenger side airbags as well as side airbags. For occupant safety, verify the location of all airbags before installing radio equipment.



For passenger safety, mount the radio securely so that the unit will not break loose in the event of a collision. This is especially important in station wagons, vans and similar type installations where a loose radio could be extremely dangerous to the vehicle occupants.

## 9 EQUIPMENT REQUIRED

The equipment required for installing the M7100<sup>IP</sup> Series Mobile Radio is listed below:

- Crimping tool for fuse holder
- Electric drill for drilling mounting holes
- Drills and circle cutters, as follows:
  - No. 31 (1/8-inch) drill
  - No. 27 (9/64-inch) drill
  - 5/8-inch drill or circle cutter
  - 3/4-inch circle cutter, hole saw or socket punch
- Phillips and flat-blade screwdrivers
- POZIDRIV<sup>®</sup> driver
- No. 20 TORX<sup>®</sup> driver



Be careful to avoid damaging some vital part (fuel tank, transmission housing, etc.) of the vehicle when drilling mounting holes. Always check to see how far the mounting screws will extend below the mounting surface before installing.



If pilot holes must be drilled, remove all metal shavings from drilling holes before installing screws.

# 10 INSTALLATION

## 10.1 RUNNING CABLES

To assure the feasibility of the planned cable routings, it is suggested that the cables be run before mounting the radio. The M7100<sup>IP</sup> Series mobile radio may be installed as a Front Mount or a Remote Mount. The type of mount, the application and the options to be installed should be considered when planning the cable runs. Figure 10-1 and Figure 10-2 provide Interconnection Diagrams for typical installations and should be referenced throughout the installation.

Be sure to leave some slack in each cable going to the radio so that the radio may be pulled out for servicing with the power applied and antenna attached. Coil any surplus cables and secure them out of the way. Try to route the cables away from locations where they will be exposed to heat (exhaust pipes, mufflers, tailpipes, etc.), battery acid, sharp edges or mechanical damage or where they will be a nuisance or hazard to automobile mechanics, the driver or passengers. Keep wiring away from electronic computer modules, other electronic modules and ignition circuits to help prevent interference to these components and radio equipment.

In addition, try to utilize existing holes in the firewall, trunk wall and the channels above or beneath doors. Channels through door and window columns that are convenient for running cables may also be used, unless rigid or flexible conduit is to be installed for cable runs.



When attaching cables to the mobile, control head, or bracket, do not exceed the following torque specifications when tightening screws: 6 in-lb or 0.68 N-m or 7 kgf-cm.

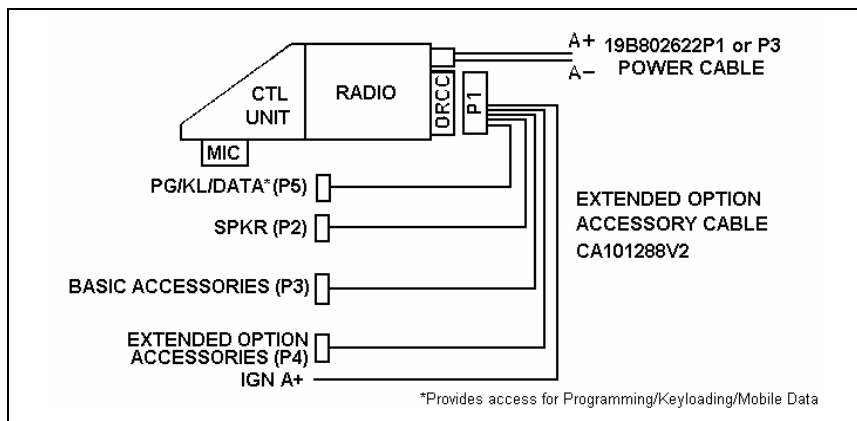
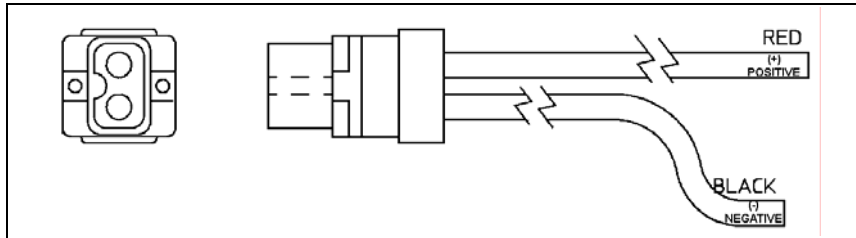


Figure 10-1: Front Mount Extended Option Accessory Interconnections







**Figure 10-3: Power Cable 19B802622P3 (50W and Below) or 19B802622P1 (60W and Above)**

## **10.1.2 Accessory Cable**

### **10.1.2.1 Front Mount**

The Front Mount Extended Option Accessory Cable, at one end, consists of the extended options plug (P4); basic accessories connector (P3); connection for field programming, keyloading, and mobile data applications (P5); the speaker connector (P2); and the ignition sense lead. At the other end is plug P1. P1 connects to the Option/Remote Control Connector (ORCC) which is mounted on the back of the radio (refer to Figure 10-4).



### 10.1.2.2 Remote Mount

The Remote Mount Extended Option Accessory Cable, at one end, consists of the extended option plug (P4), the basic accessories connector (P3), and the speaker connector (P2). At the other end is the plug P1. P1 will connect to the Option Connector (OPT) which is mounted on the back of the Radio Interface Adapter (RIA). See Figure 10-5.

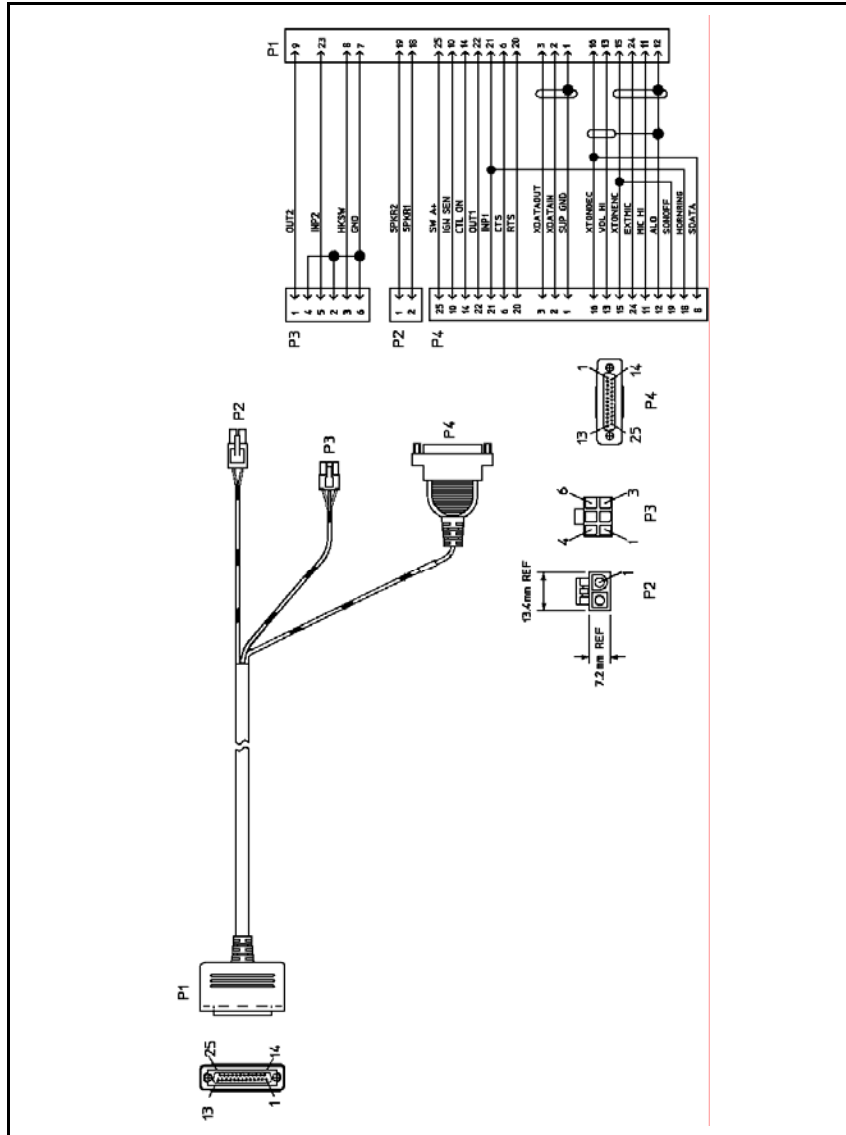


Figure 10-5: Remote Mount Extended Option Accessory Cable  
19B802554P7

### 10.1.3 Ignition Sense (All Applications)



**NOTE**

The radio, as shipped from the factory, has the "ignition sense" feature disabled. As such, the radio will be powered ON or OFF as determined by the front panel ON/OFF/VOLUME control only (assuming A+ and A- are connected). If it is desired to enable the "ignition sense" feature, open the top cover of the radio and remove the shield from logic PWB. Slide switch S951 from position 3-2 to 1-2. Replace shield and top cover. Be sure to apply correct torque to screws holding top cover in place (refer to the appropriate Maintenance Manual).



**NOTE**

The "Accessory" point should drop to ZERO volts when cranking the engine and return to +12 volts after the engine is started. If a point is chosen that drops to a voltage between zero and +12 volts, the radio might execute a power-up cycle several times during start up. It is recommended that the terminal be measured with a voltmeter to be sure it shuts off (goes to zero volts) during the cranking of the engine.

The fuse holder must be attached to the yellow sense lead along with the ring terminal as follows:

1. Cut the yellow sense lead approximately 6-12" from the end that will be connected to the ignition sense point.
2. Strip the insulation from each end of the short lead and from the end of the long lead at least 3/8".
3. Insert the stripped end of the long lead and one end of the short lead into the narrow end of each fuse holder half.
4. Crimp the leads in the fuse holder halves with a crimping tool.
5. Insert the 3-amp fuse into one end of the fuse holder and join the two fuse holder halves firmly together.
6. Attach the ring terminal to the end of the short lead and connect this lead to the ignition "ON" sense point [preferably an "Accessory" point (in the vehicle fuse panel) that is switched on when the vehicle ignition switch is in the ACCESSORY and RUN positions].



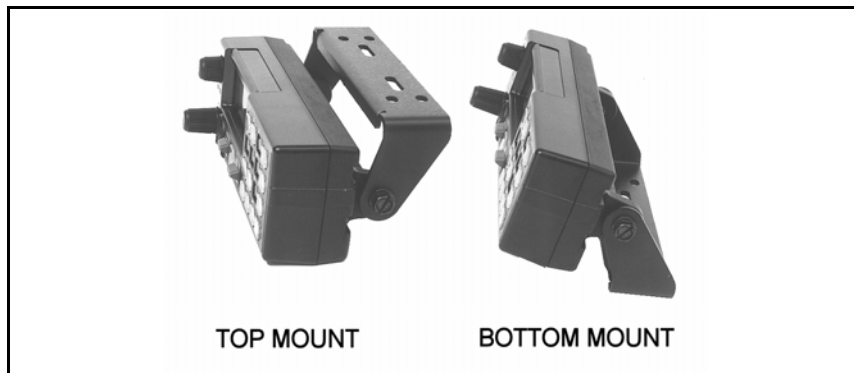
Certain problems might be encountered when accessory equipment is connected to the ignition or accessory lines of the vehicle, where these lines can have large filter capacitors and a leakage path present. If the radio does not turn off within a reasonable amount of time after the ignition is turned off, first try a different accessory or ignition sense pick-up point in the vehicle. Many vehicles have more than one circuit that is switched by the ignition switch, and one might be available that does not have large filter capacitors or a leakage path present.

If a different pick-up point cannot be found, add a 470-ohm, 1-watt resistor from the ignition sense pick-up point to ground. This will discharge the capacitor(s) or reduce the leakage voltage to a low value. Current drain through this resistor will be minimal (less than 0.03A) when the ignition is switched on.

#### **10.1.4 Control Cable (Remote Mount Only)**

The Control Cable is used to connect the Control Unit (through the RIA) to the Radio Transceiver in remote applications. Plug P2, at one end, connects to the Remote Control Cable Connector (RCCC) mounted on the back of the RIA. The Ignition Sense wire is also part of P2. The connection, P5, is available for field programming, keyloading, or mobile data applications. The other end of the Control Cable (P1) connects to the ORCC mounted on the back of the radio. See Figure 10-6.





**Figure 10-7: Control Unit Mounting Bracket Installation**

## **10.2 CONTROL UNIT MOUNTING**

*(Remote Applications Only)*

1. Using the bracket as a template, mark and drill the mounting holes. Be sure to leave enough room at the rear of the control unit for the cable connector and to allow the unit to swivel. Refer to Figure 10-7 for control unit mounting bracket installation.
2. Secure the mounting bracket using the four No. 10 x 3/4 self-tapping screws supplied (use No. 10 x 1-1/2 if needed.).
3. Secure the control unit to the bracket with the two 1/4 - 20 x 1/2 hex head screws and lock washers provided.

## **10.3 PIGTAIL BRACKET**

The Pigtail Bracket is used to mount the DB15 connector for easier user access. The DB15 connector is used to make radio programming and keyloading by the customer easier, eliminating the need to dismantle the radio or Control Unit. There are two Pigtail brackets: one for use with the Control Unit and one for use with the radio mounting bracket. The following sections include procedures to mount the pigtail brackets in each of these configurations.

### **10.3.1 Pigtail Bracket – Control Unit Mounting**

For Control Unit mounting, the Pigtail Bracket is attached to the side of the Control Unit bracket using existing mounting bracket hardware. The Pigtail Bracket can be mounted to either the right or the left side of the Control Unit. Hardware Kit, KT101533V6, contains Pigtail mounting bracket and hardware required to attach Pigtail to bracket.





**Figure 10-8: Control Unit Mounting Bracket with Pigtail Bracket**

1. Attach DB15 connector to the rectangular end of bracket with 2 pan head machine screws and washers. See Figure 10-9.



**Figure 10-9: DB15 Connector Mounted on Control Unit Pigtail Bracket**

2. Remove the  $\frac{1}{4}$  - 20 x  $\frac{1}{2}$  hex head screw and washer from the side of the Control Unit bracket where the Pigtail installation is desired. Retain this hardware for Step 4.
3. Align the single hole at the end of the Pigtail Bracket with the holes in the Control Unit bracket and the Control Unit.
4. Replace washer, insert hex head screw, and tighten. See Figure 10-10.



**Figure 10-10: Pigtail Bracket Installed on Control Unit**

### **10.3.2 Pigtail Bracket – Radio Mounting**

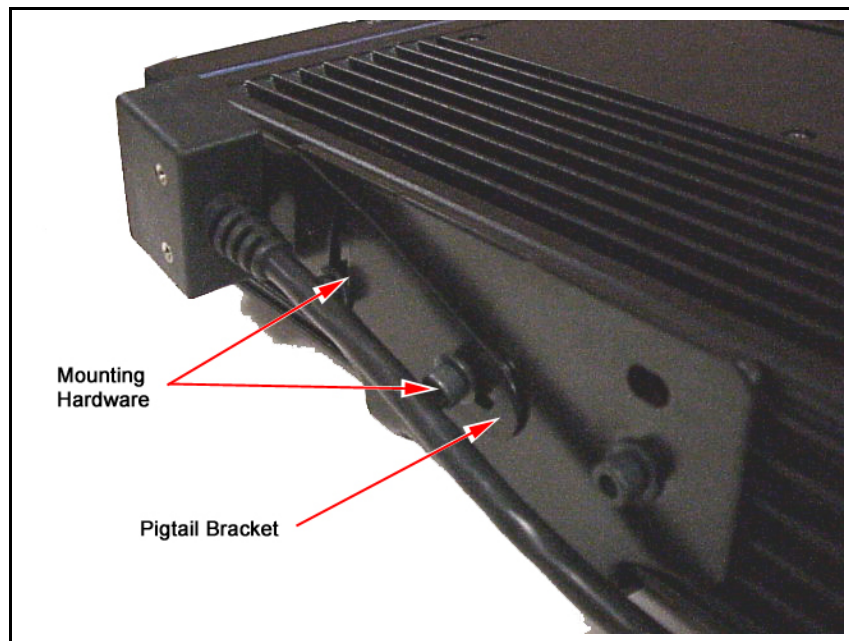
For Radio mounting, the Pigtail Bracket is attached to either side of the Radio mounting bracket. Hardware Kit, KT101533V5, contains the Pigtail Bracket, and hardware to attach the Pigtail to the bracket.

1. Attach DB15 connector to rectangular end of the Pigtail Bracket using 2 pan head machine screws and washers. See Figure 10-11.



**Figure 10-11: DB15 Connector Mounted on Radio Pigtail Bracket**

2. Position the Pigtail Bracket with the connector facing away from the side and towards the front of the radio. The Pigtail Bracket can be installed on either side of the radio.
3. Remove the first two radio mounting bracket screws and lockwashers located closest to the front of the radio. Retain this hardware for Step 5.
4. Align the bracket hole at the smaller end of the Pigtail Bracket with the middle hole on the radio bracket and the corresponding hole in the radio chassis. Insert an M5 x 10mm hex head screw and lockwasher.
5. The other slot in the Pigtail Bracket will enable flexible positioning of the pigtail. Position the bracket, and insert the remaining M5 x 10mm hex head screw and lockwasher. Tighten both of the hex head screws to 7 N-m (61 in-lb) to maintain the desired Pigtail position. See Figure 10-12.

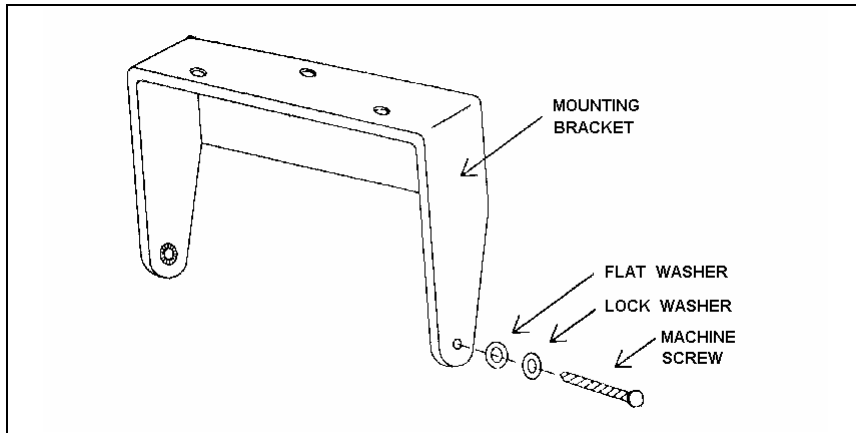


**Figure 10-12: Pigtail Bracket Mounted on Radio**

## **10.4 SPEAKER**

The speaker kit includes the speaker, mounting bracket and connecting cable. Position the speaker toward the operator but follow the guidelines presented on pages 5 through 14 to assure it does not present a hazard in the event of an accident. The speaker may be mounted on the lower edge of the instrument panel, the firewall or above the windshield in some trucks.

1. Use the mounting bracket as a template for locating the mounting holes and mount the speaker as shown in Figure 10-13.
2. Refer to the applicable installation procedures for connection of the speaker to the accessory cable.



**Figure 10-13: Speaker Mounting Bracket**

## **10.5 MICROPHONE HANGER AND/OR HOOKSWITCH MOUNTING**

The microphone hanger or hookswitch should be mounted in a location convenient to the operator where it will not interfere with the safe operation of the vehicle or be a hazard to the vehicle passengers. The hanger and hookswitch are designed to be mounted with the open end of the mounting button slot pointed upward. Use the hanger or hookswitch as a template to mark and drill the mounting holes. Mount the hanger or hookswitch with the self-tapping screws provided.

## **10.6 SIREN AND LIGHT**

For instructions about installing the Federal Signal Corporation Siren and Light Kit, refer to the Federal Signal Corporation Installation Instructions (Federal Systems part number 255287B, rev. B or higher).

Program the radio to work with the Federal Systems Siren and Light Kit, using the instructions outlined in the ProGrammer On-Line Help.

In a remote mount installation, three jumpers must be reconfigured in the remote control unit. These jumpers are located on the Remote Interface Adapter (RIA), a PC board in the back half of the unit. To access these jumpers, the RIA must be removed from the control unit as follows:

1. Disassemble the Control Unit using steps given in LBI-39175.
2. Flex circuit PC2 does not need to be disengaged from J2, providing care is taken to avoid excessive bending.
3. Reconfigure jumper A/B to center/B, jumper C/D to center/D, and jumper E/F to center/F.
4. Carefully reassemble the RIA to front control panel, making sure that there is adequate alignment and lubricant for the black o-ring gasket at the mechanical interface between the RIA and the control panel. This maintains the moisture seal of the control panel.

**NOTE:** The following issues have been reported on some M7100 Siren/Light installations using the Federal Signal Corporation Siren and Light Kit:

- Occasional false activation of siren and light functions when the ignition is turned to the “on” position and/or when the vehicle is started.
- Occasional failure to enable siren or light functions via control head, which can be temporarily resolved by either power cycling the radio or turning the car ignition “off” and then “on” again.

To resolve these issues above, modify the Federal Systems control cable as follows:

1. Remove the outer shell from the DB25 side of the Federal Systems control cable.
2. Add a jumper from pin 1 to pin 19.

This modification to the SS2000 cable harness will disable the M7100’s capability to turn on and off the SS2000 from the front of the control head. The SS2000 will now be turned on and off strictly by its own ignition switch trigger line (red wire from 12 pin Molex<sup>®</sup> connector on SS2000 siren box). Follow the SS2000 Federal Signal Corporation installation instructions to attach the red ignition line correctly.

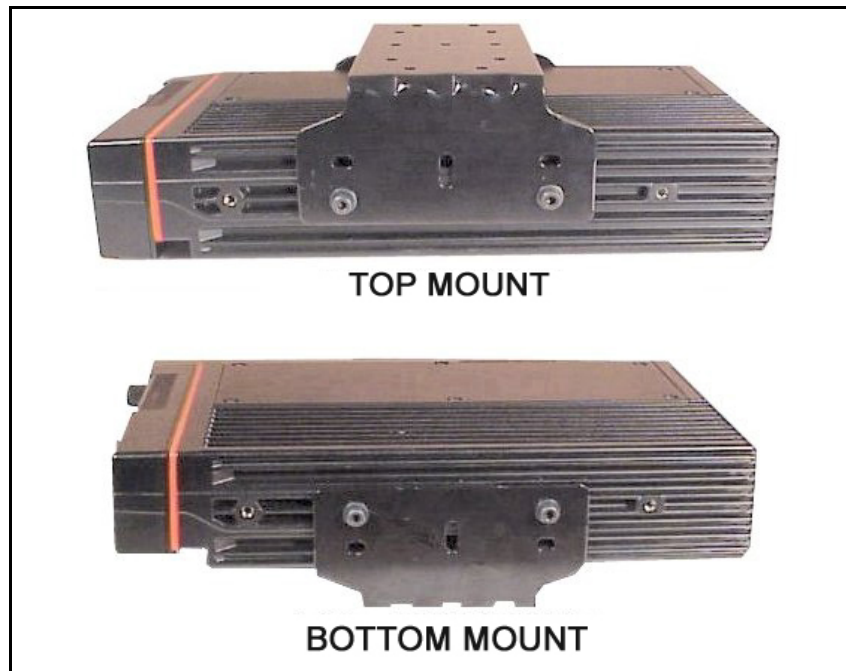
## **10.7 RADIO MOUNTING AND FINAL HOOK-UP**

### **10.7.1 Front Mount**

Typically, the bracket shown in Figure 10-14 is used for Front Mount applications. The bracket can be mounted so that it is either above or below the radio for the user’s convenience. The bracket pictured in Figure 10-7 can also be used for Remote Mount applications. The following instructions are for a Front Mount installation using the bracket shown in Figure 10-14.

1. Use the supplied mounting bracket as a template to locate the position for each of the drill holes. Be sure to leave enough room at the front and rear of the radio for cable connections. Drill No. 27 (9/64) pilot holes.

2. Mount bracket with four 1/4"-14 x 3/4" sheet metal screws (use 1/4"-14 x 1-1/2" screws if needed).
3. Place radio into mounting bracket and secure with the M5 x 10 mm hex head screws and M5 lock washers supplied using a No. 20 Torx driver.
4. Connect antenna coaxial cable to antenna connector (TNC).
5. Connect front mount accessory cable connector P1 to the Option/Remote Control Connector (ORCC) and secure with the two captive screws in the connector to the radio.



**Figure 10-14: Mounting Bracket Installation (110W VHF Shown)**

6. Connect front mount accessory cable connector P2 to speaker cable connector.
7. Connect power cable to power connector on rear of radio unit and secure with the two captive screws to the radio unit.
8. Connect the microphone connector to the connector on the front panel and secure with the captive screw.

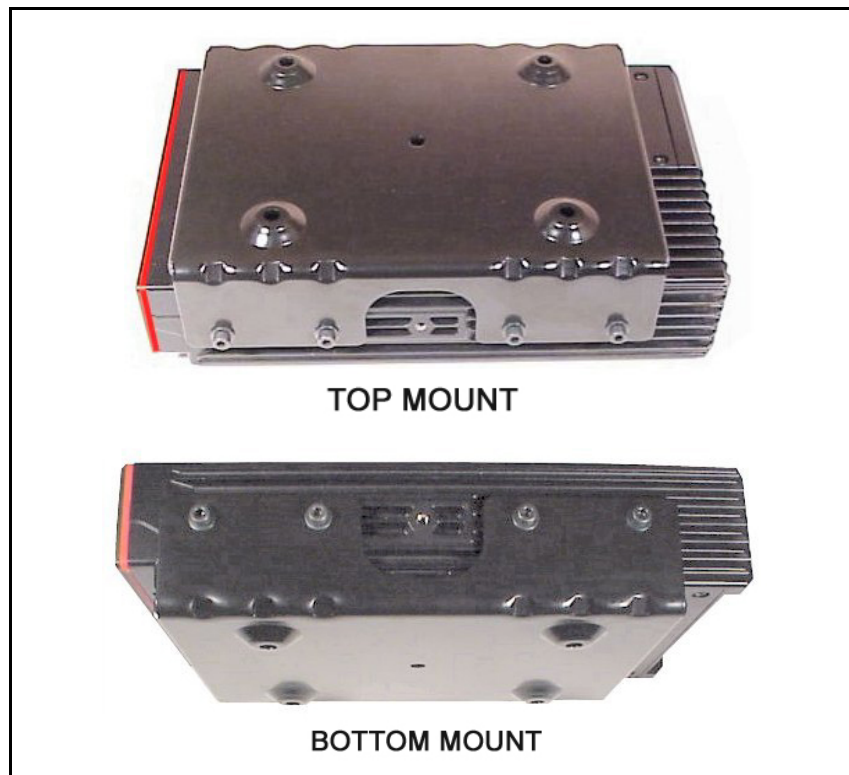


Do not torque the microphone connector screw greater than 2 in-lb. Alternatively, “finger tight plus 1/4 turn” is acceptable.

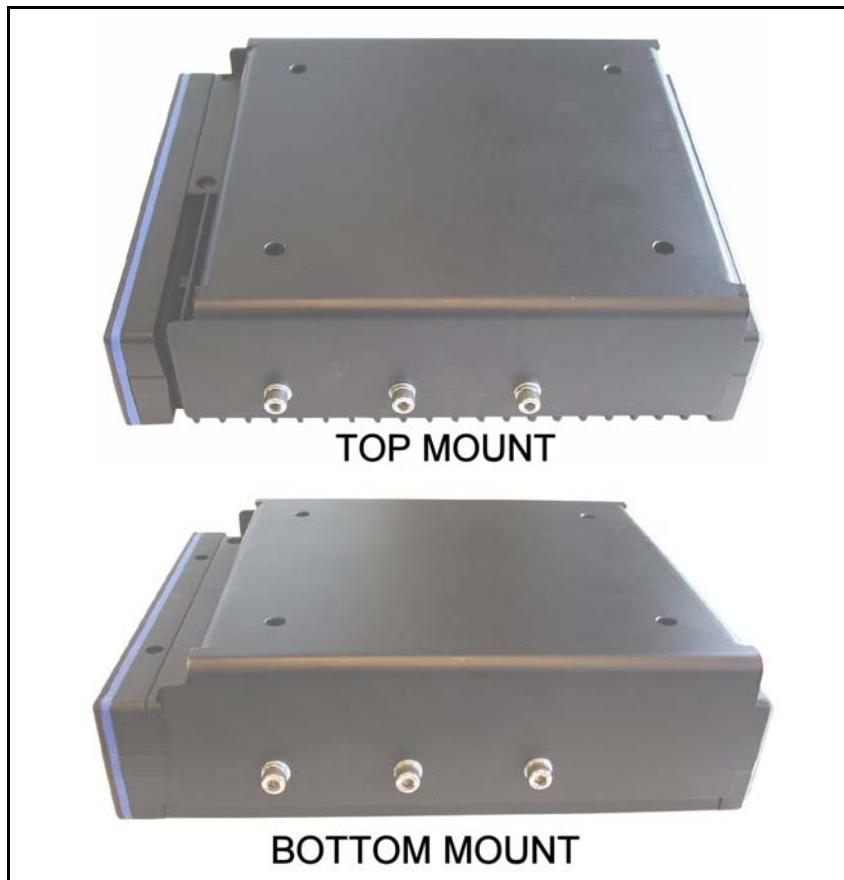
9. If there are no other accessory connections, tie back plug P3 to main cable.
10. Recheck all connections before inserting fuse into transmit fuse assembly.

### **10.7.2 Remote Mount Installation**

The bracket shown in Figure 10-15 is used with the 110W VHF M7100 in Remote Mount configurations. (The 110W VHF radio is not available in Front Mount configurations.) The bracket shown in Figure 10-16 is used with the 800 MHz, UHF-H, UHF-L, and 50W VHF M7100 radios in Remote Mount configurations. The following instructions are for Remote Mount configurations using the brackets shown in Figure 10-15 and Figure 10-16.



**Figure 10-15: Remote Mounting Bracket Installation (60W TX and Above)**



**Figure 10-16: Remote Mounting Bracket Installation (50W TX and Below)**

1. Using the bracket as a template, mark and drill the mounting holes using a No. 27 drill. Be sure to leave enough room at the rear of the radio unit for the cable connections.
2. Secure the mounting bracket using four 1/4"-14 x 3/4" sheet metal screws (use 1/4"-14 x 1" if needed). The bracket can be mounted so that it is either above or below the radio for the user's convenience.
3. Slide the radio unit into the bracket by aligning bracket guides with grooves on each side of radio (rear of radio should be inserted first). Slide radio back until screw holes in front of bracket align with screw holes in side of radio. (Refer to Figure 10-15 or Figure 10-16 depending on radio and bracket type.)
4. Secure radio to the bracket with M5 x 10 mm socket head screws provided (7 N-m or 61 in-lb). There are three screws per side (6 total) for



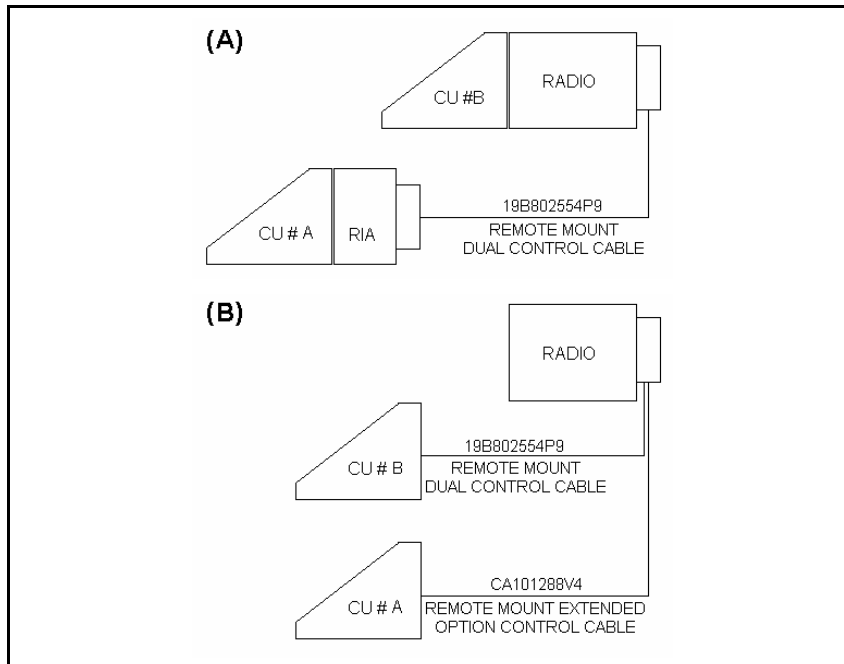
the 50W TX and Below radios and four screws per side (8 total) for the 60W TX and Above radios.

5. Connect antenna coaxial cable to antenna connector (TNC).
6. Connect remote control cable connector P1 to the ORCC connector on the radio unit and secure with the two captive screws.
7. Connect other end of remote control cable to the remote control cable connector (RCCC) on the remote control unit.
8. Connect remote mount accessory cable connector P1 to the option connector (OPT) on control unit. Then connect the speaker to connector P2 and accessory connector P3 to any options (hookswitch, etc.). If connector P3 is not used, insulate and tie back to main cable.
9. Recheck all connections and cables. Insert fuse into transmit fuse assembly.

## 11 DUAL CONTROL UNIT INSTALLATION

Dual Control units can be configured for either front mount or remote mount radio units. Each configuration provides for a Main Control Unit and an Auxiliary Control Unit. In the front mount dual control unit configuration, the Main Control Unit is on the Radio Unit itself, with the Auxiliary Control Unit located separately in a convenient location (see Figure 11-1A). In the remote mount dual control unit configuration, the Main Control Unit is typically located in the vehicle cab, with the Auxiliary Control Unit located separately in a convenient location (see Figure 11-1B).

All radio units and control units in the Dual Control configuration **MUST BE PROGRAMMED** prior to final installation. It is recommended that the units be first programmed at an Authorized Service Center, and then transferred to the user's installation.



**Figure 11-1: Dual Control Unit – Basic Configurations for Front Mount (A) and Remote Mount (B) Installations**

The Radio and Control Units must be programmed in a sequential procedure to provide each Control Unit with the proper identification code.

## 11.1 PROGRAMMING PROCEDURE - FRONT MOUNT CONFIGURATION



### NOTE

This programming procedure applies to uninstalled and installed units.

1. Connect the M7100 Front Mount Radio with ProGrammer, as shown in Figure 11-2. Program the radio with the following parameters:

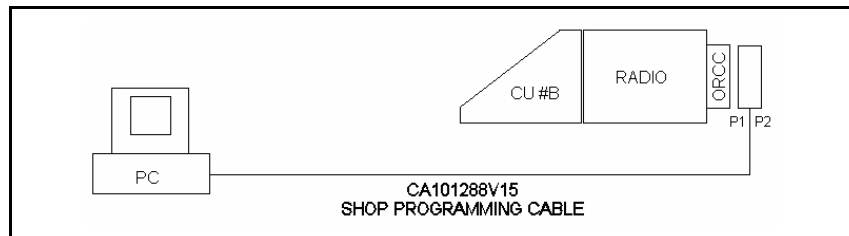


Figure 11-2: M7100 Unit PC Programming Configuration

### NETWORK OPTIONS

#### Dual Control Setup

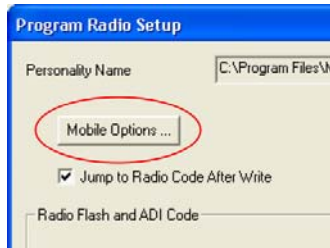
Dual Control	Enable
Audio Mode	Active or Parallel
Switching Mode	Independent or Slaved
Siren Light Controller	Unit A
Siren Light Connection	Unit A
Speaker	Enable (Active Low: Output 2)

#### Multiple Radio Setup

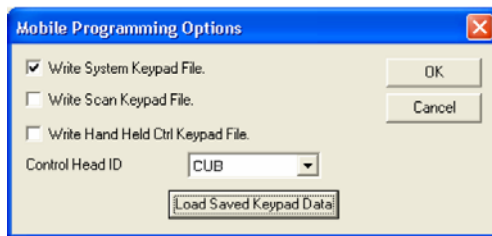
Multiple Radio	Disable
----------------	---------

2. Initiate programming.

3. Select Mobile Options from the Program Radio Setup.



4. Write Keypad File.



- Select the type of control unit; System, Scan or Hand Held Controller.
- Select Control Head ID CUB.
- After selecting the keypad file, select Load Saved Keypad Data or OK.



**NOTE**

If the wrong control is "Enabled," the control unit will not work.

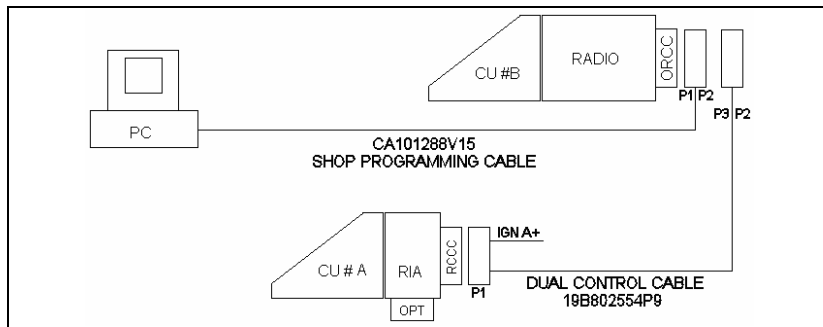


**NOTE**

**“Load Saved Keypad Data”** selection is available in R19A (or later) ProGrammer.

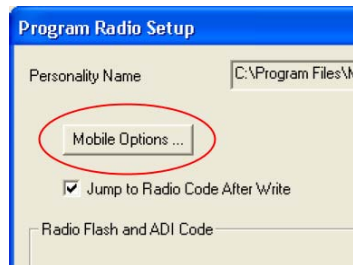
In a successful CUB programming, the “B” control unit will display “CLL B PRG SUCCESS.”

5. Connect the Front Mount Radio and the Auxiliary Control Unit together with ProGrammer, as shown in Figure 11-3.

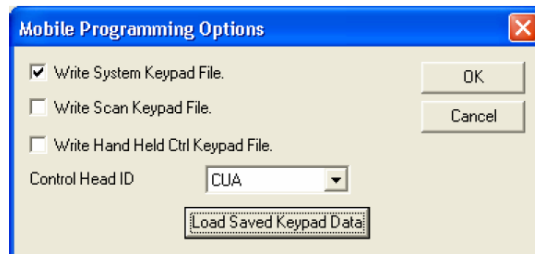


**Figure 11-3: M7100 Dual Control Unit PC Programming Configuration**

6. Initiate programming.
7. Select Mobile Options from the Program Radio Setup.



8. Write Keypad File.



- Select the type of control unit; System, Scan or Hand Held Controller.
- Select Control Head ID CUA.
- After selecting the keypad file, select Load Saved Keypad Data or OK.



If the wrong control is "Enabled," the control unit will not work.



“Load Saved Keypad Data” selection is available in R19A (or later) ProGrammer.

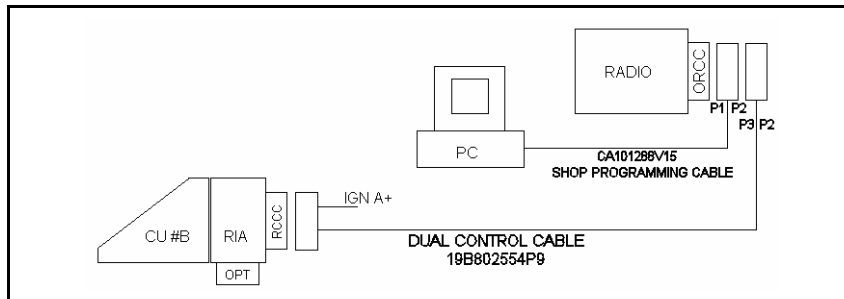
Note that in a Dual Control Unit front/remote mount installation, the Main Control Unit has ID “B” and the Auxiliary Control Unit has ID “A”.

## 11.2 PROGRAMMING PROCEDURE - REMOTE MOUNT CONFIGURATION

The Radio and Control Units must be programmed in a sequential procedure, in order to provide each Control Unit with the proper identification code.



This programming procedure applies to uninstalled and installed units.



**Figure 11-4: M7100 PC Programming Configuration Remote Mount**

1. Connect the M7100 Remote Mount Radio with ProGrammer, as shown in Figure 11-4. Program the radio, using the shop programming cable CA101288V15, with the following parameters:

### NETWORK OPTIONS

#### Dual Control Setup

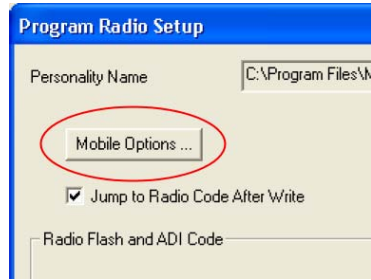
Dual Control	Enable
Audio Mode	Active or Parallel
Switching Mode	Independent or Slaved
Siren Light Controller	Unit A
Siren Light Connection	Unit A

Speaker Enable (Active High: Output 2)

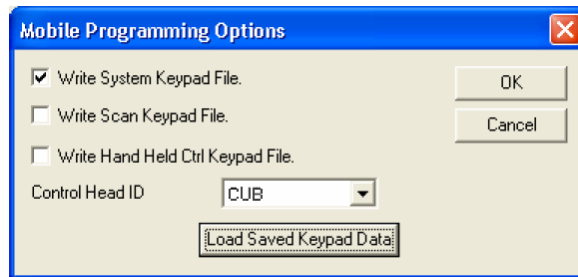
### Multiple Radio Setup

Multiple Radio Disable

2. Initiate programming.
3. Select Mobile Options from the Program Radio Setup.



4. Write Keypad File.



- Select the type of control unit; System, Scan or Hand Held Controller.
- Select Control Head ID CUB.
- After selecting the keypad file, select Load Saved Keypad Data or OK.



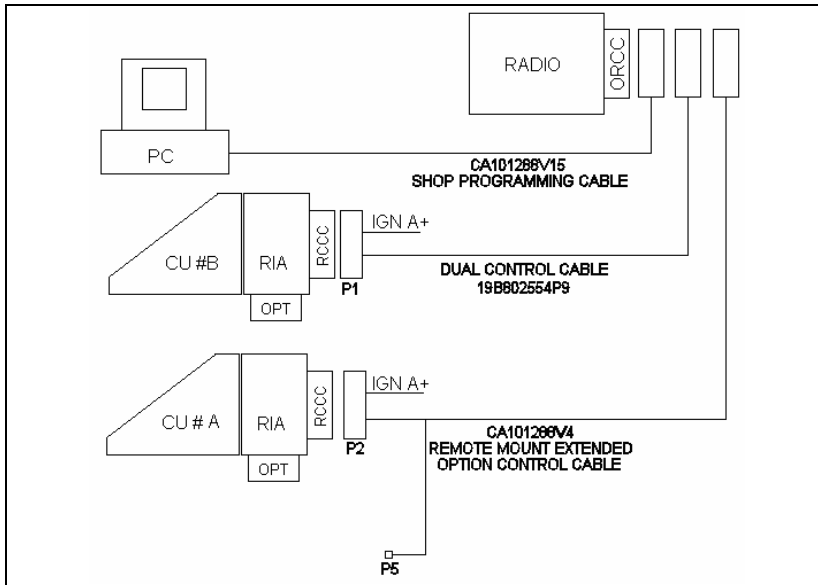
If the wrong control is "Enabled," the control unit will not work.



**“Load Saved Keypad Data”** selection is available in R19A (or later) ProGrammer.

In a successful CUB programming, the “B” control unit will display “CLL B PRG SUCCESS.”

5. Connect the Remote Mount Radio and the Auxiliary Control Unit together with ProGammer, as shown in Figure 11-5. Program this configuration using the shop programming cable CA101288V15.



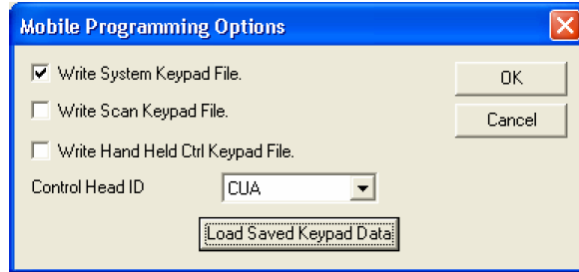
**Figure 11-5: M7100 Dual Control Unit PC Programming Configuration Remote Mount**

6. Initiate programming.
7. Select Mobile Options from the Program Radio Setup.





8. Write Keypad File.



- Select the type of control unit; System, Scan or Hand Held Controller.
- Select Control Head ID CUA.
- After selecting the keypad file, select Load Saved Keypad Data or OK.



NOTE

If the wrong control is "Enabled," the control unit will not work.

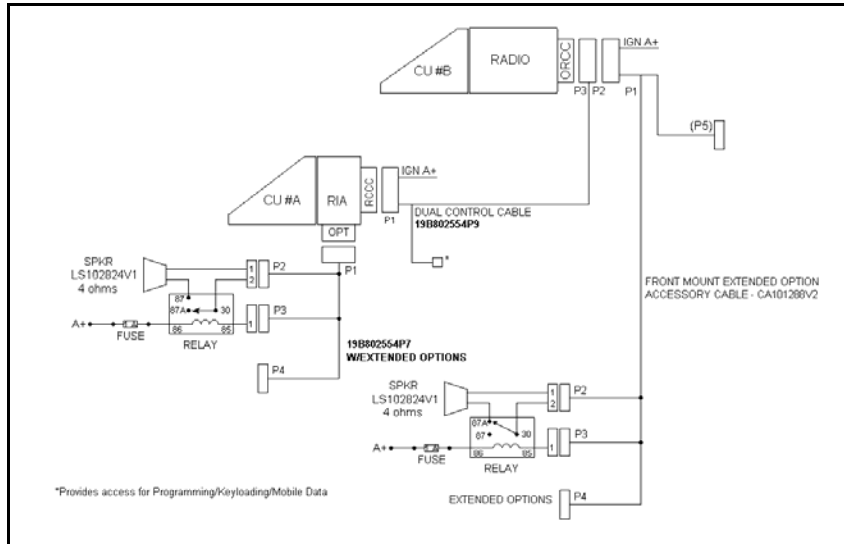


NOTE

**“Load Saved Keypad Data”** selection is available in R19A (or later) ProGrammer.

Note that in a Dual Control Unit remote/remote mount installation, the Main Control Unit has ID “A” and the Auxiliary Control Unit has ID “B”.

## 11.3 INSTALLATION INSTRUCTIONS FOR FRONT MOUNT DUAL CONTROL UNITS



**Figure 11-6: M7100 Dual Control Unit Front/Remote Mount Installation Configuration**

The Dual Control Unit feature is configured such that only one control unit can be used for Extended Option accessories. **All Extended Option functions are only available at the Main Control Unit.**

1. Referring to Figure 11-6, run the Dual Control Cable (19B802554P9 – see Figure 11-8) between locations for the Radio Unit and Auxiliary Control Unit. Be sure to locate the P2/P3 connector assembly at the Radio Unit.
2. After installing Radio Unit mounting hardware in the normal fashion, connect the Dual Control Cable connector (P3) to the Radio Unit. Tighten the two jackscrews on P3. Next, connect the Accessory Cable (CA101288V2) Connector (P1) to the Dual Control Cable Connector (P2), and tighten the jackscrews on P2. Connect the power cable, and install Radio Unit in mounting bracket.
3. After installing the Auxiliary Control Unit in the normal fashion, connect the Dual Control Cable (P1) to Auxiliary Control Unit, and tighten jackscrews.
4. Connect the Remote Mount Accessory Cable (19B802554P7) to the Auxiliary Control Unit.
5. A yellow Ignition Sense lead is provided on the Dual Control Cable and the Front Mount Accessory Cable. If the “**Ignition Sense**” feature is enabled on the Radio Unit, it is necessary to connect only one of the

yellow leads provided, whichever is convenient. Tape back the unused yellow lead. *Note: "Ignition Sense" feature must be enabled before use (see Page 29 for details).*

6. Install the Speakers in convenient locations near the Radio Unit and Auxiliary Control Unit. For special Front/Remote Mount configurations that require both speakers to operate simultaneously (parallel audio), refer to the configuration-specific parallel audio installation instructions in Step 6.a. For typical speaker installation proceed to Step 7.

6.a.

#### **Parallel Audio Installation – Front/Remote Mount**

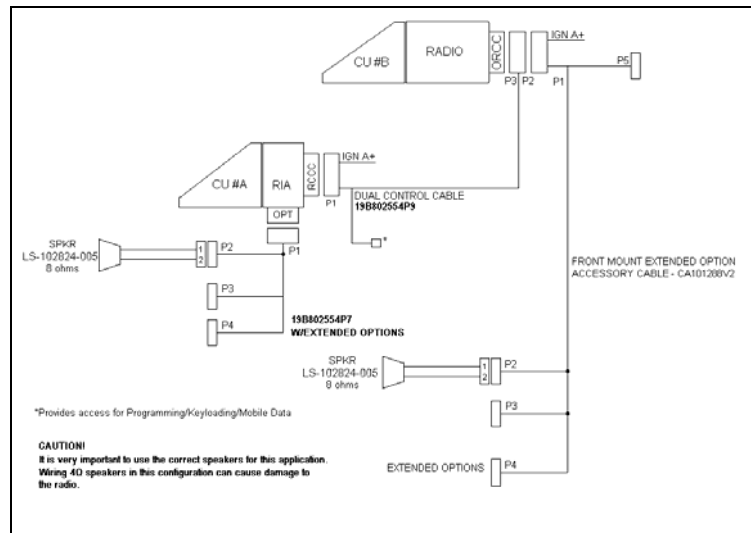
In special configurations that require both speakers to operate at the same time (simultaneous audio), install the speakers for parallel audio operation.

Refer to Figure 11-7 for the Parallel Audio Setup Installation. Perform the following steps to install parallel audio speakers:

- A. Use the two 8 $\Omega$  speakers, part number LS-102824-005, in place of the two 4 $\Omega$  speakers, part number LS102824V1.
- B. Hardwire each speaker directly (without relays) as shown in Figure 11-6.

#### **NOTE**

**It is very important to use the correct speakers for this application. Wiring 4 $\Omega$  speakers in this configuration can cause damage to the radio.**



**Figure 11-7: M7100 Dual Control Unit Front/Remote Mount Installation Configuration – Parallel Audio**

7. Install a relay (19A149299P1), from the kits supplied, at a location near the leads from each speaker. For mounting, use the #8x3/4" sheet metal screw and nut plate supplied with each kit.
8. At a convenient point cut one of the wires in each of the 2-wire speaker cables, spread the leads, and strip the ends. Crimp a 1/4" tab receptacle to each end.
9. Radio Unit Speaker: Connect the lead nearest the speaker to **Pin 87A** of the relay. Connect the lead nearest the connector to Pin 30 of the relay. Connect the connector to the Accessory Cable P2 (refer to Figure 11-6).
10. Auxiliary Control Unit Speaker: Connect the lead nearest the speaker to **Pin 87** of the relay. Connect the lead nearest the connector to Pin 30 of the relay. Connect the connector to the Accessory Cable P2 (refer to Figure 11-6).
11. For each relay: Connect a #18 AWG black wire between the relay, Pin 85 and Accessory Cable P3-1 (labeled "**OUT2**" on the schematic diagrams in the service manual). Use a 1/4" tab receptacle on the relay side and mating Molex connector and pins on the accessory cable side. Connect the mating Molex connector to the Accessory Cable P3 when finished (refer to Figure 11-6).
12. For each relay: Connect a #18 AWG red wire to the relay, Pin 86. Cut to length, and connect to the 1A fuse holder (supplied). Use crimp on connectors supplied. Connect the other side of the 1 amp fuse holder to A+ battery source or vehicle A+ fuse block. Use #18 AWG red wire and ring lug supplied, if needed (see Figure 11-6).

- Check dual control operation using the M7100 operator's manual (available at [www.macom-wireless.com](http://www.macom-wireless.com)) as a test guide. In ProGammer, make sure the "DUAL CONTROL SPEAKER" is programmed **ACTIVE LOW**. Set Output to "2."

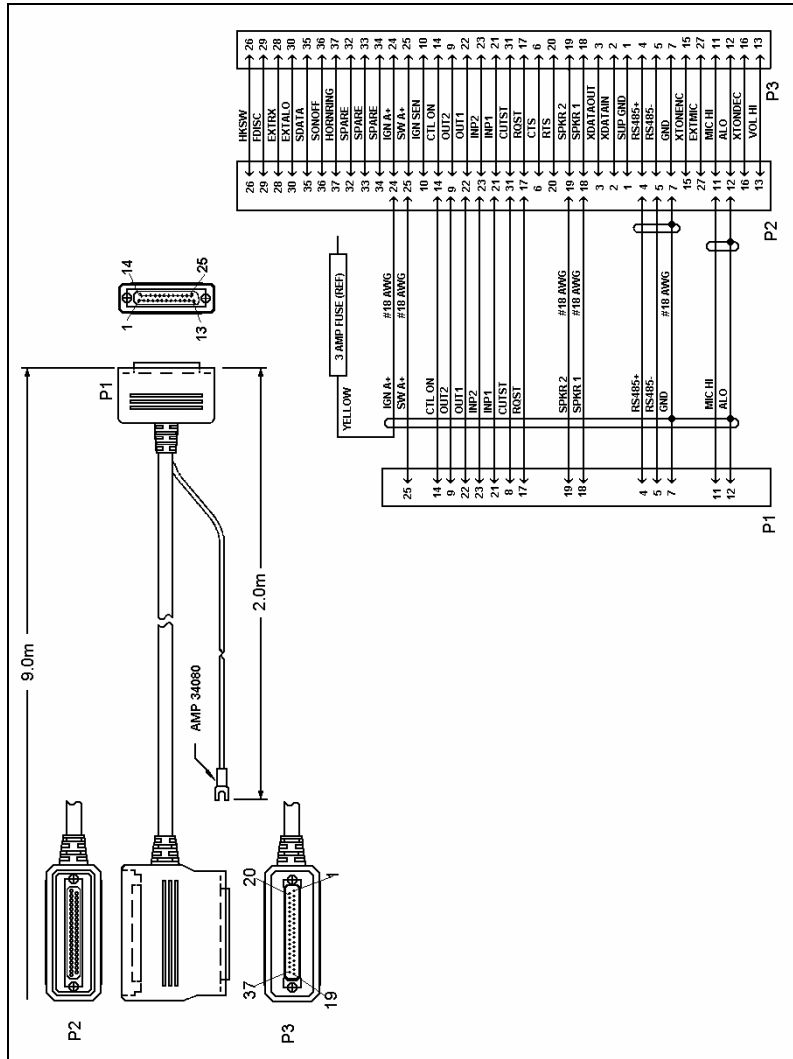
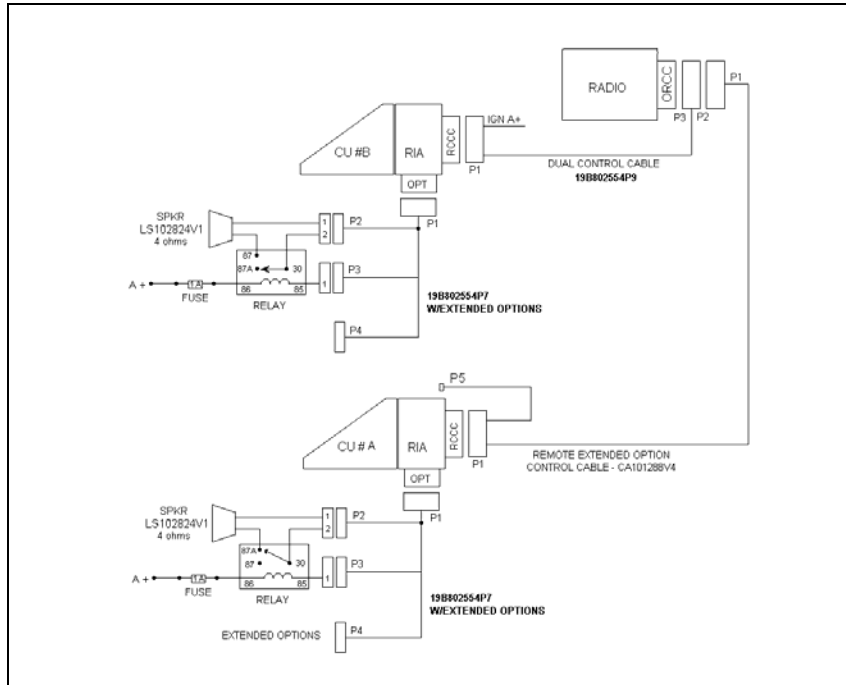


Figure 11-8: Dual Control Cable 19B802554P9

## 11.4 INSTALLATION INSTRUCTIONS FOR REMOTE MOUNT DUAL CONTROL UNITS



**Figure 11-9: M7100 Dual Control Unit Remote/Remote Mount Installation Configuration**

1. Referring to Figure 11-9, run the Remote Control Cable (CA101288V4) between locations for the Radio Unit and Main Control Unit.
2. Run the Dual Control Cable (19B802554P9 – see Figure 11-8) between locations for the Radio Unit and Auxiliary Control Unit. Be sure to locate the P2/P3 connector assembly at the radio unit.
3. After installing the Radio Unit in the normal fashion, connect the dual control cable connector (P3) to the Radio Unit. Tighten the two jackscrews on P3. Next, connect the Remote Control Cable connector (P1) to the Dual Control Cable connector (P2), and tighten jackscrews on P2.
4. After installing the Main Control Unit in the normal fashion, connect the Remote Control Cable (P2) to the Main Control Unit, and tighten jackscrews.
5. After installing the auxiliary control unit in the normal fashion, connect the Dual Control Cable (P1) to the Auxiliary Control Unit, and tighten jackscrews.

6. Connect the Remote Mount Extended Option Accessory Cable (19B802554P7) to the Auxiliary Control Unit and the Main Control Unit.  
**Please note: All extended option functions are only available at the Main Control Unit.**
  7. A yellow ignition sense lead is provided on each control cable. If the **“Ignition Sense”** feature is enabled on the Radio Unit, it is necessary to connect only one of the yellow leads provided, whichever is convenient. Tape back the unused yellow lead. See page 29 for details.
  8. Install the Speakers in convenient locations near the Radio Unit and Auxiliary Control Unit. For special Remote Mount/Remote Mount configurations that require both speakers to operate simultaneously (parallel audio), refer to the configuration-specific parallel audio installation instructions in Step 8.a. For typical speaker installation proceed to Step 9.
- 8.a

#### **Parallel Audio Installation – Remote Mount/Remote Mount**

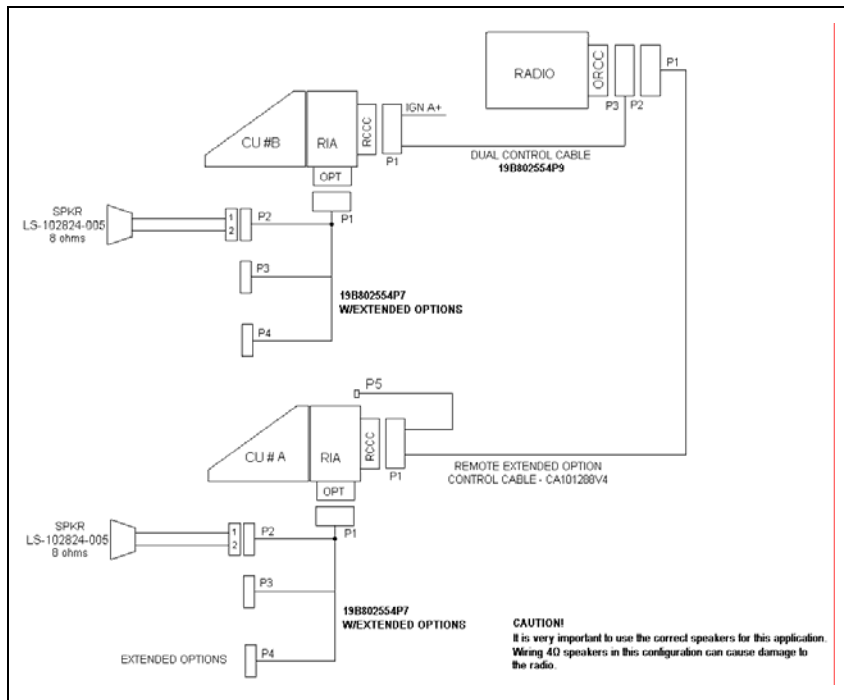
In special configurations that require both speakers to operate at the same time (simultaneous audio), install the speakers for parallel audio operation.

Refer to Figure 11-10 for the Parallel Audio Setup Installation. Perform the following steps to install parallel audio speakers:

- A. Use the two 8 $\Omega$  speakers, part number LS-102824-005, in place of the two 4 $\Omega$  speakers, part number LS102824V1.
- B. Hardwire each speaker directly (without relays) as shown in Figure 11-9.

#### **NOTE**

**It is very important to use the correct speakers for this application, wiring 4 $\Omega$  speakers in this configuration may cause damage to the radio.**



**Figure 11-10: M7100 Dual Control Unit Remote/Remote Mount Installation Configuration – Parallel Audio**

9. Install a relay (19A149299P1) from the kits supplied at a location near the leads from each speaker. For mounting, use the #8 X 3/4" sheet metal screw and nut plate supplied with each kit.
10. At a convenient point cut one of the wires in each of the 2-wire speaker cables, spread the leads, and strip the ends. Crimp a 1/4" tab receptacle to each end.
11. Main Control Unit Speaker: Connect the lead nearest the speaker to **Pin 87** of the relay. Connect the lead nearest the connector to Pin 30 of the relay. Connect connector to the accessory cable P2 (refer to Figure 11-9).
12. Auxiliary Control Unit Speaker: Connect the lead nearest the speaker to **Pin 87A** of the relay. Connect the lead nearest the connector to Pin 30 of the relay. Connect the connector to accessory cable P2 (refer to Figure 11-9).
13. For Each Relay: Connect a #18 AWG black wire between the relay, Pin 85 and accessory cable P3-1 (labeled **"OUT2"** on schematic diagrams in the maintenance manual). Use a 1/4" tab receptacle on the relay side and a mating Molex connector and pins on the accessory cable side. Connect the mating Molex connector to the accessory cable P3 when finished (refer to Figure 11-9).



14. For Each Relay: Connect one end of a #18 AWG red wire to the relay, Pin 86. Cut the lead to length, and connect the other end to the 1 amp fuse holder supplied. Use crimp on connectors supplied. Connect the other side of the 1 amp fuse holder to the A+ battery source or a vehicle A+ fuse block. Use a #18 AWG red wire and a ring lug supplied, if needed (refer to Figure 11-9).
15. Check dual control operation, using the operator's manual (available at [www.macom-wireless.com](http://www.macom-wireless.com)) as a test guide. In ProGrammer, make sure the "DUAL CONTROL SPEAKER" is programmed **ACTIVE HIGH**. Set Output to "2."

## 12 DUAL RADIO UNITS

The Dual Radio feature can be configured for two remote mount radio units or for one front mount unit and one remote mount unit. In remote mount configurations the Control Unit is typically located in the vehicle cab, with the Radio Units located side-by-side in vehicle trunk. In front/remote mount configurations the front mount unit is located in the vehicle cab, with the remote mount unit located in a convenient location nearby. The remote/remote mount configuration is the preferred installation, since a separate control unit is required to program the remote unit in a front/remote mount configuration.

The following Dual Radio Unit configurations are not allowed:

- Any configuration using a DIN cassette mount.
- Any installation where Extended Options are required from both Radio Units. Extended options are supported in one Radio Unit only.



**NOTE**

Public Address (PA) Mode can be enabled or disabled from the Master Radio Unit **ONLY**.

### 12.1 PRE-INSTALLATION PROGRAMMING PROCEDURE – DUAL RADIO UNITS

Both Radio Units in the Dual Radio configuration **MUST BE PROGRAMMED** prior to final installation. It is recommended that the units be first programmed at an Authorized Service Center, and then transferred to the user's installation.

These configurations provide for a Master Radio Unit and a Slave Radio Unit. In the remote/remote mount configuration, the Master Radio Unit is always the radio most directly connected to the Control Unit. In the front/remote mount configuration, the Master Radio Unit is always the front mount radio. Extended Options are allowed only in the Master Radio Unit. Programming each radio is straightforward, with one radio programmed as a Master radio and one as a Slave radio.

1. Decide which Radio Unit will be the Master Unit. Configure the radio for programming as shown in the applicable maintenance manual.
2. Program the Master Radio Unit (refer to Section 12.1.1).
  - a. In the “Multi-Radio” field of ProGrammer, select “Master.”
  - b. Select any M7100 keypad programming options if the keypad is to be programmed. The M7100 keypad options can only be programmed with “multi-radio” set to “Master” in a dual radio personality.

3. Program the unit normally. Include Extended Option features, if purchased.
4. Program the Slave Unit (refer to the programming configuration that follows).
  - a. Connect the Slave Radio Unit for programming. Be sure to use the programming configuration for remote mount and supply the required control unit for a front/remote mount dual radio configuration.
  - b. In the "Multi-Radio" field of ProGrammer, select "Slave."
5. Program the unit normally. Do NOT include Extended Option features.

Both radio units are now ready for vehicular installation.

### **12.1.1 Programming Configuration**

#### **NETWORK OPTIONS**

##### **Dual Control Setup:**

Dual Control	Disable
Speaker	Disable

##### **Multiple Radio Setup:**

Multiple Radio	Enable
Radio Type	Slave or Master
Power Up Volume	5
Mute Time-Out	30.0
Termination	Enable

##### **Master Radio Setup:**

Display	Selected for Master radio only
Power Up	Enable for Master radio only
Power Up Radio	Master for Master radio only
Receive Emergency	Enable for Master radio only
Received Audio	Enable for Master radio only

##### **Multiple Radio ProSound Settings:**

MuRPS	Disable for Master radio only
-------	-------------------------------

To write the keypad file to the radio, specify the type of control unit. If the control unit is a System model, place a check by the Write System Keypad File control. If the control unit is a Scan model, place a check by the Write Scan Keypad File control. If the wrong control is "Enabled", the control unit

will not work. Select Control Head ID. After selecting the keypad file, select Load Saved Keypad Data or OK.

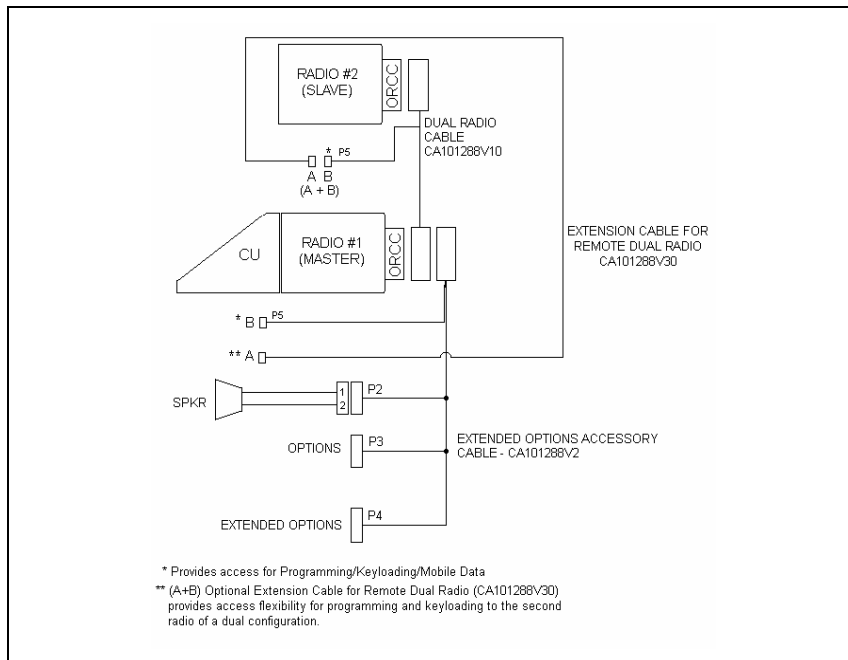


**NOTE**

“Load Saved Keypad Data” selection is available in R19A (or later) ProGrammer.

## **12.2 INSTALLATION INSTRUCTIONS FOR FRONT/REMOTE MOUNT DUAL RADIO CONFIGURATION**

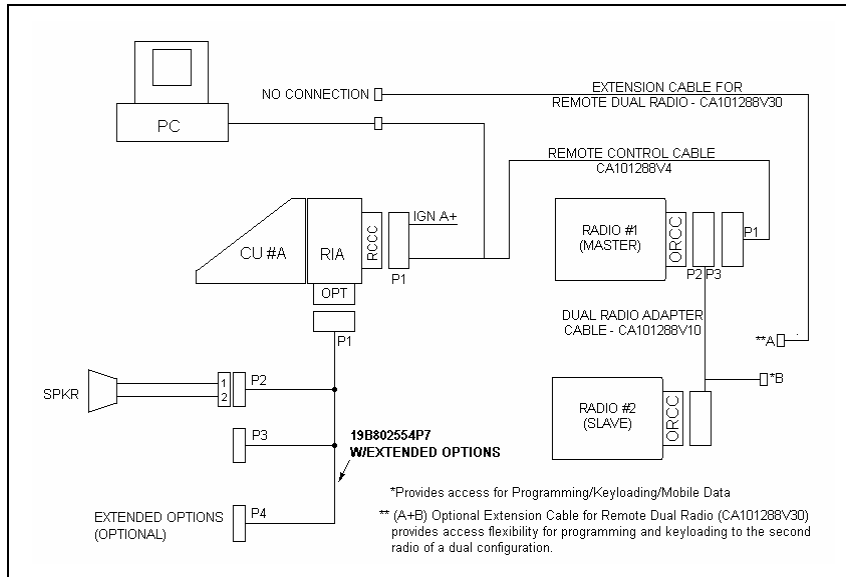
1. Plan the mounting locations of the two Radio Units. Note that the maximum cable length allowed between the two radios is two meters. Run Dual Radio Cable (CA101288V10) between locations for Master and Slave Radio Units (refer to Figure 12-1). Be sure to locate the P2/P3 connector assembly at the Master Radio Unit.
2. After installing Master Radio Unit mounting hardware, connect the Dual Radio Cable Connector (P3) to the Master Radio Unit. Tighten the two jackscrews on P3. Next, connect the Accessory Cable (CA101288V2) Connector (P1) to the Dual Radio Cable Connector (P2), and tighten to jackscrews on P2.
3. Connect the Microphone and Accessories. Refer to Accessory Installation Manual for proper connection of Accessories.
4. Connect Power Cable and Antenna then install Master Radio Unit in mounting bracket.



**Figure 12-1: M7100 Dual Radio Front Mount/Remote Mount Installation Configuration**

5. Connect "IGN A+" lead, if option is desired. Be sure internal switch S951 is set properly. Refer to NOTE on Page 29 of this manual for details.
6. After installing Slave Radio Unit in its mounting hardware, connect Dual Radio Cable (P1), and tighten jackscrews. Be sure S951 setting on Slave Radio Unit is same as for Master Radio Unit. Connect Power Cable and Antenna to Slave Radio.
7. Check Dual Radio operation, using Operator's Manual MM102341V1 (available at [www.macom-wireless.com](http://www.macom-wireless.com)) as a guide.

## 12.3 INSTALLATION INSTRUCTIONS REMOTE/REMOTE MOUNT DUAL RADIO CONFIGURATION



**Figure 12-2: M7100 Dual Radio Remote Mount/Remote Mount Installation Configuration**

1. Plan the mounting locations of the two Radio Units. Note that the maximum cable length allowed between the two radios is two meters. Referring to Figure 12-2, run Dual Radio Cable (CA101288V10) between locations for Master and Slave Radio Units. Be sure to locate the P2/P3 connector assembly at the Master Radio Unit.
2. After installing Master Radio Unit mounting hardware, connect the Dual Radio Cable Connector (P3) to the Master Radio Unit. Tighten the two jackscrews on P3.
3. Next, route the Remote Mount Extended Option Control Cable (CA101288V4) between the Control Head and Master Radio locations. After installing the Control Head, connect the Remote Control Cable Connector (P2) to the Control Head.
4. Connect "IGN A+" lead, if option is desired. Be sure internal switch S951 on the Master Radio is set properly. Refer to Page 29 of this manual for details.
5. Connect Accessory Cable (19B802554P7) Connector (P1) to Control Head.
6. Connect the Microphone and Accessories. Refer to the Accessory Installation Manual for proper connection of Accessories.

7. Now, connect Remote Control Cable Connector (P1) to the Dual Radio Cable Connector (P2), and tighten to jackscrews on P2.
8. Connect the Power Cable and Antenna, then install the Master Radio Unit in the mounting bracket.
9. After installing the Slave Radio Unit in its mounting hardware, connect Dual Radio Cable (P1), and tighten the jackscrews. Be sure the S951 setting on the Slave Radio Unit is the same as for the Master Radio Unit. Connect the Power Cable and Antenna to the Slave Radio.
10. Check Dual Radio operation, using operator's manual MM102341V1 (available at [www.macom-wireless.com](http://www.macom-wireless.com)) as a guide.

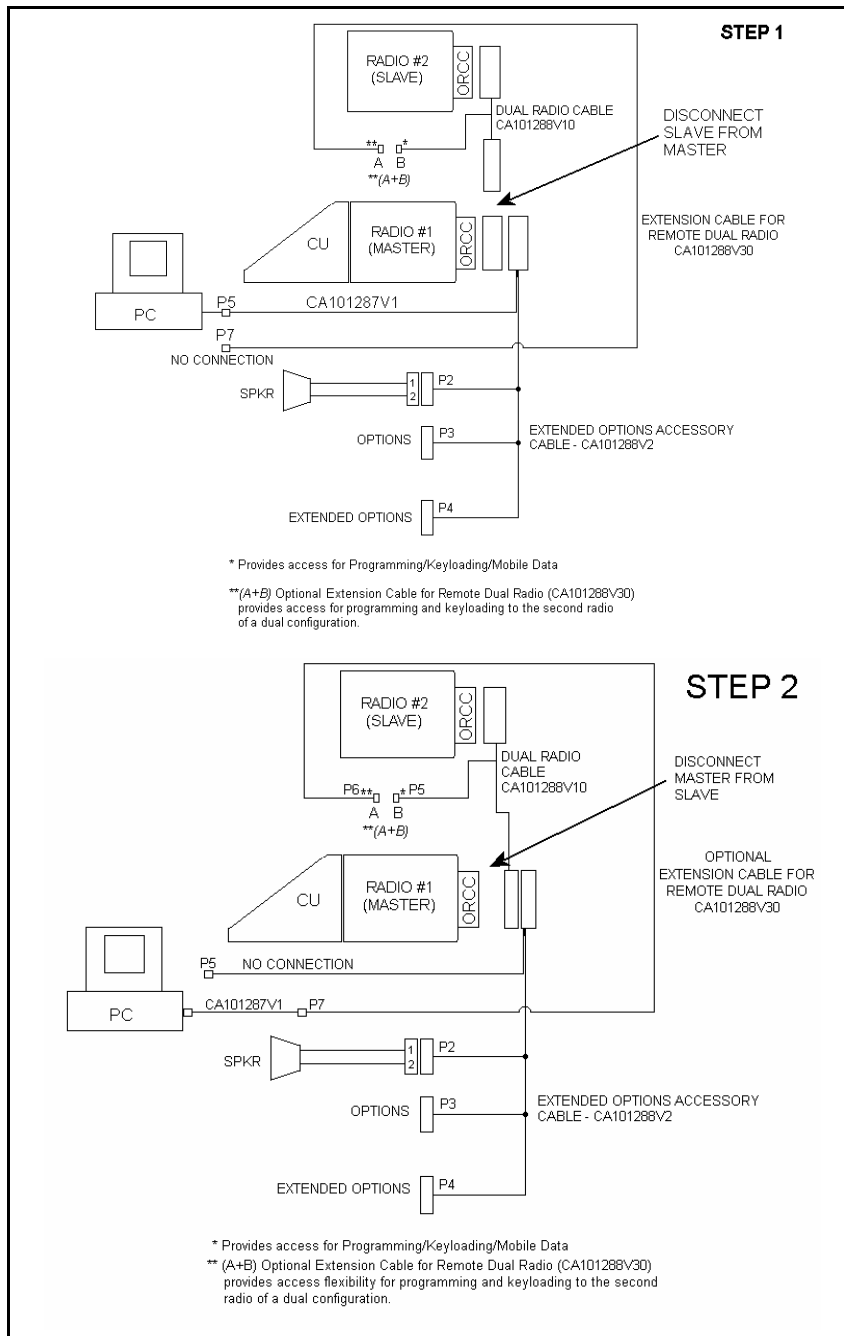
## **12.4 FIELD PROGRAMMING – DUAL RADIO UNITS**

Once installed, the M7100 can be programmed through connector P5 on cable assemblies CA101288V2, V4, and V10. Please Note: Keyloading and Data functions are also available through the P5 connector on these cables. Also note that extended options are supported on ONE radio unit only. Follow the applicable instructions for extended option programming.

### **12.4.1 Field Programming Procedure for Front/Remote Mount Dual Radio Configuration**

The Radio and Control Units must be programmed in a sequential procedure in order to provide each Control Unit with the proper identification code.

1. Configure the M7100 Master Radio per the ProGrammer setup shown in Figure 12-3, STEP 1, with the Slave Radio disconnected. Program the Master Radio with the control configurations per the Pre-Installation Programming Procedure – Dual Radio Units and adjust as necessary for the desired application.
2. Now configure the Slave Radio as shown in Figure 12-3, STEP 2. The Master Radio should now be disconnected with the Slave Radio connected as shown. Program the Slave Radio with the configuration per the Pre-Installation Programming Procedure – Dual Radio Units and adjust as needed for the desired application.



**Figure 12-3: Dual Radio Configuration – Front/Remote Mount PC Programming Procedure**



#### **12.4.2 Field Programming Procedure for Remote/Remote Mount Dual Radio Configuration**

The Radio and Control Units must be programmed in a sequential procedure in order to provide each Control Unit with the proper identification code.

1. Connect the M7100 Master Radio per the ProGrammer setup as shown in Figure 12-4, STEP 1 with the Slave Radio disconnected. Program the Master Radio with the control configurations per the Pre-Installation Programming Procedure – Dual Radio Units and adjust as necessary for the desired application.
2. Connect the Slave Radio with ProGrammer as shown in Figure 12-4, STEP 2. The Master Radio should now be disconnected, with the Slave Radio connected as indicated. Program the Slave Radio with the configuration per the Pre-Installation Programming Procedure – Dual Radio Units and adjust as necessary for the desired application.



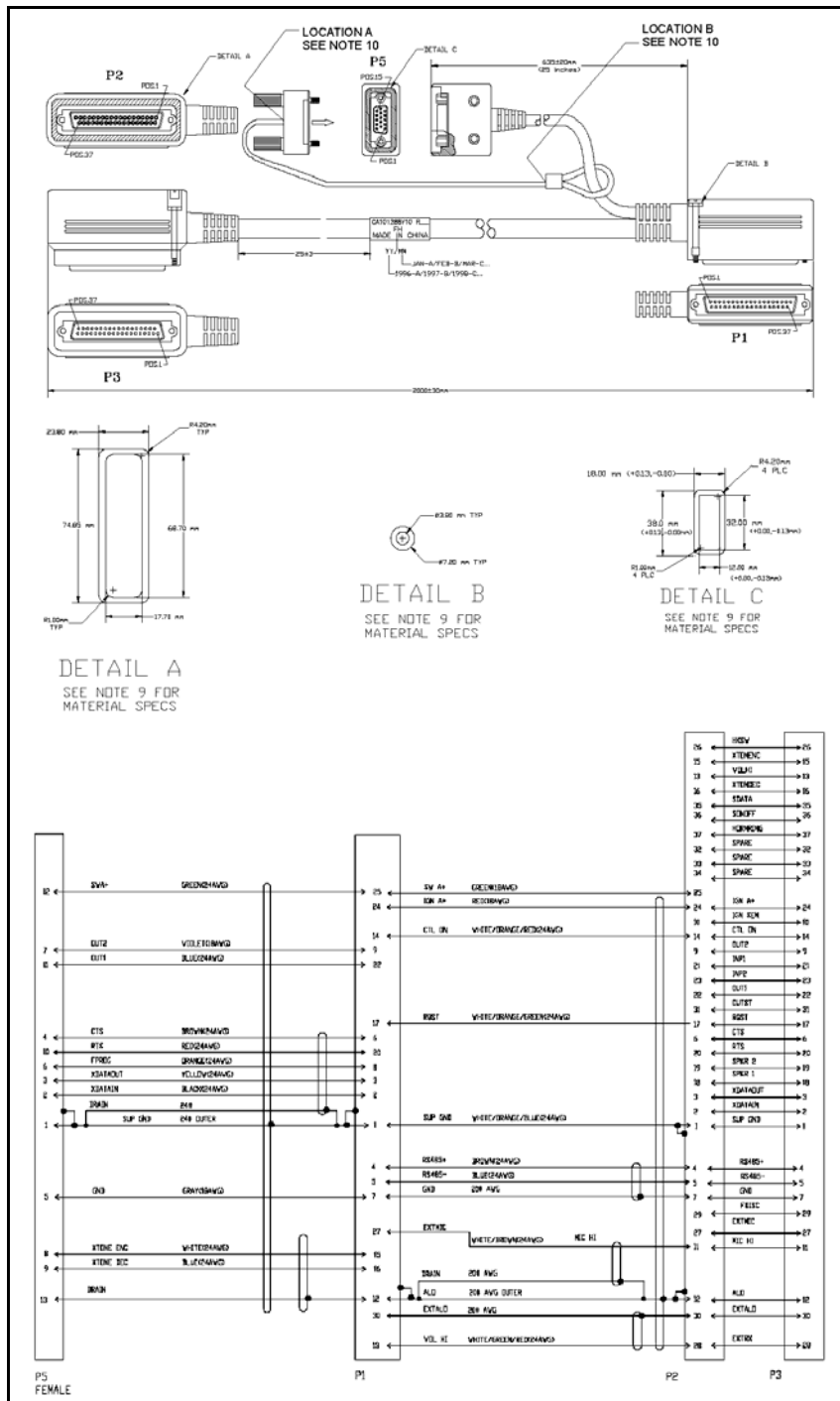


Figure 12-5: Dual Radio Control Cable (CA101288V10)

## 12.5 ANTENNA

Installation instructions for the antenna are packaged with the antenna. The antenna must be installed in accordance with good engineering practice for optimum results.

### 12.5.1 Typical Mobile Antenna Installation

A permanent mount-type antenna must be located in the center of the roof.



**See Section 2 for further information regarding Maximum Permissible Exposure (MPE) limits of RF radiation set by the FCC.**

Route the antenna cable away from locations where it will be exposed to heat, sharp edges or mechanical damage, and where it will be out of the way of the driver, passengers, or vehicles mechanics. Wherever possible, use existing holes in the trunk wall and channels above or beneath doors and window columns.

Avoid routing the antenna cable near any electronic modules or along side any vehicle wiring.

Connect the antenna cable to the TNC on the radio, being careful not to twist the cable.

## 13 WARRANTY

- A. M/A-COM, Inc. (hereinafter "Seller") warrants to the original purchaser for use (hereinafter "Buyer") that Equipment manufactured by or for the Seller shall be free from defects in material and workmanship, and shall conform to its published specifications. With respect to all non-M/A-COM Equipment, Seller gives no warranty, and only the warranty, if any, given by the manufacturer shall apply. Rechargeable batteries are excluded from this warranty but are warranted under a separate Rechargeable Battery Warranty (ECR-7048).
- B. Seller's obligations set forth in Paragraph C below shall apply only to failures to meet the above warranties occurring within the following periods of time from date of sale to the Buyer and are conditioned on Buyer's giving written notice to Seller within thirty (30) days of such occurrence:
1. for fuses and non-rechargeable batteries, operable on arrival only.
  2. for parts and accessories (except as noted in B.1) sold by Seller's Service Parts Operation, ninety (90) days.
  3. for PANTHER™ Series handportable and mobile radios, two (2) years.
  4. for all other equipment of Seller's manufacture, one (1) year.
- C. If any Equipment fails to meet the foregoing warranties, Seller shall correct the failure at its option (i) by repairing any defective or damaged part or parts thereof, (ii) by making available at Seller's factory any necessary repaired or replacement parts, or (iii) by replacing the failed Equipment with equivalent new or refurbished Equipment. Any repaired or replacement part furnished hereunder shall be warranted for the remainder of the warranty period of the Equipment in which it is installed. Where such failure cannot be corrected by Seller's reasonable efforts, the parties will negotiate an equitable adjustment in price. Labor to perform warranty service will be provided at no charge during the warranty period only for the Equipment covered under Paragraph B.3 and B.4. To be eligible for no-charge labor, service must be performed at a M/A-COM factory, by an Authorized Service Center (ASC) or other Servicer approved for these purposes either at its place of business during normal business hours, for mobile or personal equipment, or at the Buyer's location, for fixed location equipment. Service on fixed location equipment more than thirty (30) miles from the Service Center or other approved Servicer's place of business will include a charge for transportation.
- D. Seller's obligations under Paragraph C shall not apply to any Equipment, or part thereof, which (i) has been modified or otherwise altered other than pursuant to Seller's written instructions or written approval or, (ii) is normally consumed in operation or, (iii) has a normal life inherently shorter than the warranty periods specified in Paragraph B, or (iv) is not properly stored, installed, used, maintained or repaired, or, (v) has been subjected to any other kind of misuse or detrimental exposure, or has been involved in an accident.
- E. The preceding paragraphs set forth the exclusive remedies for claims based upon defects in or nonconformity of the Equipment, whether the claim is in contract, warranty, tort (including negligence), strict liability or otherwise, and however instituted. Upon the expiration of the warranty period, all such liability shall terminate. The foregoing warranties are exclusive and in lieu of all other warranties, whether oral, written, expressed, implied or statutory. NO IMPLIED OR STATUTORY WARRANTIES OF MERCHANTABILITY OR FITNESS FOR PARTICULAR PURPOSE SHALL APPLY. IN NO EVENT SHALL THE SELLER BE LIABLE FOR ANY INCIDENTAL, CONSEQUENTIAL, SPECIAL, INDIRECT OR EXEMPLARY DAMAGES.

This warranty applies only within the United States.

**M/A-COM, Inc.**  
1011 Pawtucket Blvd.  
Lowell, MA 01853  
1-877-OPENSKY

**M/A-COM, Inc.**  
221 Jefferson Ridge Parkway  
Lynchburg, VA 24501  
1-800-528-7711

ECR-7047C

M/A-COM Technical Publications would particularly appreciate feedback on any errors found in this document and suggestions on how the document could be improved. Submit your comments and suggestions to:

Wireless Systems Business Unit  
M/A-COM, Inc.  
Technical Publications  
221 Jefferson Ridge Parkway  
Lynchburg, VA 24501

Or

E-mail us at: [techpubs@tycoelectronics.com](mailto:techpubs@tycoelectronics.com)

Fax your comments to: 1-434-455-6851

## NOTES



***Tyco Electronics Wireless Systems Segment***  
*221 Jefferson Ridge Parkway*  
*Lynchburg, Virginia 24501*  
*(Outside USA, 1-434-385-2400) Toll Free 1-800-528-7711*  
[www.macom-wireless.com](http://www.macom-wireless.com)

*Printed in U.S.A.*