

*future*  
The Future of Mobile Radio

**MASTR® III**  
Conventional and P25  
Base Stations

**TABLE OF CONTENTS**

Application and Assembly Diagrams.....	MM102555V1
Antenna Systems.....	LBI-38983
Site Grounding and Lightning Protection .....	AE/LZT 123 4618/1
Tower Requirements and Specifications.....	LBI-39185

**Advanced Digital Capable**

**MANUAL REVISION HISTORY**

<b>REV</b>	<b>DATE</b>	<b>REASON FOR CHANGE</b>
R1A	August 2003	Initial Release.
B	December 2004	Modified Regulatory Section.

**NOTICE!**

This manual covers M/A-COM, Inc. products manufactured and sold by M/A-COM, Inc.

This device made under license under one or more of the following US patents: 4,590,473; 4,636,791; 5,148,482; 5,185,796; 5,271,017; 5,377,229.

The voice coding technology embodied in this product is protected by intellectual property rights including patent rights, copyrights, and trade secrets of Digital Voice Systems, Inc. The user of this technology is explicitly prohibited from attempting to decompile, reverse engineer, or disassemble the Object Code, or in any way convert the Object Code into human-readable form.

MASTR and Voice Guard are registered trademarks and Aegis is a trademark of is a registered trademark of M/A-COM, Inc.

Microsoft, Windows, and WindowsNT are registered trademarks of Microsoft Corporation  
Pentium is a registered trademark of Intel Corporation.

All other brand and product names are registered trademarks, trademarks, or service marks of their respective holders.

**NOTICE!**

Repairs to this equipment should be made only by an authorized service technician or facility designated by the supplier. Any repairs, alterations or substitutions of recommended parts made by the user to this equipment not approved by the manufacturer could void the user's authority to operate the equipment in addition to the manufacturer's warranty.

This manual is published by **M/A-COM, Inc.** , without any warranty. Improvements and changes to this manual necessitated by typographical errors, inaccuracies of current information, or improvements to programs and/or equipment, may be made by **M/A-COM, Inc.** , at any time and without notice. Such changes will be incorporated into new editions of this manual. No part of this manual may be reproduced or transmitted in any form or by any means, electronic or mechanical, including photocopying and recording, for any purpose, without the express written permission of **M/A-COM, Inc.**

## TABLE OF CONTENTS

	<i>Page</i>
<b>1. REGULATORY AND SAFETY INFORMATION .....</b>	<b>7</b>
1.1 MAXIMUM PERMISSIBLE EXPOSURE LIMITS .....	7
1.2 DETERMINING MPE RADIUS .....	7
1.3 SAFETY TRAINING INFORMATION.....	7
1.4 IMPORTANT SAFETY INFORMATION.....	9
1.5 SAFETY SYMBOLS IN THIS DOCUMENT .....	10
<b>2. SPECIFICATIONS (GENERAL) .....</b>	<b>11</b>
2.1 CABINET.....	11
2.2 STATION.....	11
2.3 INTERFACE.....	12
<b>3. INTRODUCTION .....</b>	<b>13</b>
<b>4. GENERAL INFORMATION .....</b>	<b>15</b>
4.1 REFERENCE MANUALS .....	15
4.2 OPTIONS .....	17
<b>5. SITE PREPARATION .....</b>	<b>19</b>
5.1 INTRODUCTION.....	19
5.2 FACILITY PREPARATION .....	19
5.2.1 Floor Plan .....	19
5.2.2 Equipment Cabinet Placement .....	19
5.2.3 Ceiling Requirements .....	20
5.2.4 Size and Weight Considerations .....	20
5.2.5 Operating Environment .....	20
5.3 POWER INSTALLATION.....	20
5.3.1 Existing Input Power.....	20
5.3.2 AC Distribution.....	21
5.3.3 Generator System .....	21
5.3.4 AC-DC Supply .....	21
5.3.5 Battery Backup.....	22
5.3.6 UPS System.....	22
5.3.7 Electrical Power .....	22
5.4 INTER-SITE COMMUNICATIONS .....	23
5.4.1 Hardwire Installation.....	23
5.4.2 Leased Telephone Lines.....	24
5.4.3 T1 or E1 Links .....	24
5.5 PROTECTIVE GROUNDING .....	25
5.6 ANTENNA SYSTEM.....	26
5.6.1 Antenna Mounting .....	26
5.6.2 Transmission Lines .....	27
5.7 QUALITY AUDIT.....	29
5.7.1 Antenna System .....	29

## TABLE OF CONTENTS

	<i>Page</i>
5.7.2 Electrical System.....	30
<b>6. EQUIPMENT INSTALLATION .....</b>	<b>31</b>
6.1 INTRODUCTION.....	31
6.2 UNPACKING EQUIPMENT .....	31
6.3 EQUIPMENT INSTALLATION.....	32
6.3.1 Mounting Vendor Supplied RF Equipment .....	32
6.3.2 Mounting Base Station Cabinet (Typical).....	34
6.4 INTERIOR RF CABLING.....	35
6.4.1 Cable Routing.....	35
6.4.2 Install RF Cables .....	35
6.5 CONNECTING ELECTRICAL POWER.....	37
6.5.1 AC Power Distribution.....	38
6.5.2 Generator Backup.....	38
6.5.3 AC-DC Supply .....	38
6.5.4 Battery Backup.....	38
6.5.5 UPS System.....	39
6.6 POWER-UP SEQUENCE.....	39
<b>7. DC AND TONE REMOTE CONTROL INSTALLATION .....</b>	<b>40</b>
7.1 DC REMOTE INSTALLATION.....	40
7.1.1 Wiring Methods for DC Remote.....	40
7.1.2 Installation Method 1 – Single Metallic Pair.....	43
7.1.3 Installation Method 2 – Single Metallic Pair with Earth Ground.....	43
7.1.4 Installation Method 3 - Metallic Control Pair, Audio Pair.....	43
7.1.5 Installation Method 4 - Full Duplex.....	45
7.2 E & M SIGNALING.....	45
7.2.1 Standard (Type II) E & M Signaling.....	45
7.2.2 Type 1 E & M Signaling .....	46
7.3 TONE REMOTE INSTALLATION.....	46
7.3.1 Voting System Considerations .....	48
7.3.2 Function Tones.....	48
7.3.3 Wiring Methods for Tone Remote .....	49
7.3.4 Installation Method 1 – Two Wire Tone Remote.....	50
7.3.5 Installation Method 2 - Four Wire Tone Remote .....	50
7.4 T/R SHELF REMOTE CONTROL CONNECTIONS .....	50
7.4.1 Interface Board Connections.....	50
7.5 SQUELCH OPERATED RELAY OPTION (SXSU3D) .....	53
7.5.1 Installation.....	53
7.5.2 Operation.....	53
7.6 SHARED REPEATER PANEL INSTALLATION.....	55
7.6.1 General .....	55
7.6.2 Repeater Panel Interface.....	55
<b>8. STATION TEST AND ALIGNMENT PROCEDURES .....</b>	<b>58</b>
8.1 INTRODUCTION.....	58

## TABLE OF CONTENTS

	<i>Page</i>
8.2 GENERAL .....	58
8.3 SUPPORT EQUIPMENT REQUIRED .....	58
8.3.1 Hardware .....	58
8.3.2 Software .....	59
8.4 STATION CONFIGURATION .....	60
8.5 STATION ALIGNMENT .....	61
8.5.1 Preparation .....	63
8.5.2 Station Pot Defaults.....	64
8.5.3 Channel Guard (CG) Pot.....	64
8.5.4 Transmit Limiter (TX) Pot .....	65
8.5.5 Repeater Gain (RG) Pot .....	66
8.5.6 DSP Line Input (DLI) Pot .....	66
8.5.7 Compressor Gain (CP) Pot.....	67
8.5.8 Compressor Threshold (CT) Pot .....	68
8.5.9 DSP Line Cancellation (DC) Pot .....	68
8.5.10 Line Output (LO) Pot .....	69
8.5.11 P25 C4FM Deviation (DSP Module Adjustments).....	69
8.5.12 Enable the P25 Operation in the System Module.....	69
8.5.13 Adjust P25 C4FM Deviation.....	70
8.5.14 SINAD Test.....	71
8.5.15 Squelch Adjustment .....	72
8.5.16 Transmitter Forward and Reverse Power .....	72
<b>9. SYSTEM FUNCTIONAL TESTS.....</b>	<b>74</b>
9.1 GENERAL .....	74
9.2 SETUP.....	74
9.3 CONVENTIONAL RADIO TEST .....	74
9.4 P25 RADIO TEST .....	74
9.4.1 P25 Individual Calls.....	74
9.4.2 P25 Group Calls .....	74
9.5 REMOTE STATION OPERATION.....	75
<b>10. MODULE TESTING AND ALIGNMENT .....</b>	<b>76</b>
10.1 GENERAL .....	76
10.2 BENCH TESTING.....	77
10.2.1 Procedure.....	78
10.3 IN-STATION TESTING.....	79
10.3.1 Procedure.....	79
10.4 CHANGING THE BASE STATION FREQUENCY .....	79
10.4.1 Vendor Equipment .....	80
10.4.2 800 MHz Stations.....	80
10.4.3 UHF Stations .....	81
10.4.4 VHF Stations .....	81
10.5 STATION ADJUSTMENTS FOR REMOTE CONTROL OPERATION .....	82
10.5.1 Line Out Level Adjustment.....	82
10.5.2 Line In Level Adjustment .....	83

**TABLE OF CONTENTS**

	<i>Page</i>
10.5.3 DSP Level Adjustments .....	83
<b>11. PREVENTATIVE MAINTENANCE .....</b>	<b>84</b>
11.1 GENERAL .....	84
11.2 BASE STATIONS .....	84
11.2.1 Test Equipment .....	84
11.2.2 Tests .....	84
11.3 RF SYSTEM .....	85
11.3.1 Combiner .....	85
11.3.2 Multicoupler .....	85
11.3.3 Receive Filter .....	85
11.3.4 RF Cabling to Bulkhead .....	85
11.4 POWER SYSTEM .....	85
<b>12. CHECKLISTS .....</b>	<b>86</b>
12.1 SITE DATA SHEET .....	87
12.2 INSTALLER PROFILE DATA SHEET .....	88
12.3 ANTENNA SYSTEM INSTALLATION CHECKLIST .....	89
12.4 EQUIPMENT INSTALLATION CHECKLIST .....	90
12.5 POWER SYSTEM INSTALLATION CHECKLIST .....	91
12.6 REPEATER TEST DATA .....	92
12.7 PREVENTATIVE MAINTENANCE REPEATER TEST DATA .....	93

# 1. REGULATORY AND SAFETY INFORMATION

## 1.1 MAXIMUM PERMISSIBLE EXPOSURE LIMITS

**DO NOT TRANSMIT** with this base station and antenna when persons are within the **MAXIMUM PERMISSIBLE EXPOSURE (MPE)** Radius of the antenna. The MPE Radius is the minimum distance from the antenna axis that **ALL** persons should maintain in order to avoid RF exposure higher than the allowable MPE level set by the FCC.



**FAILURE TO OBSERVE THESE LIMITS MAY ALLOW ALL PERSONS WITHIN THE MPE RADIUS TO EXPERIENCE RF RADIATION ABSORPTION, WHICH EXCEEDS THE FCC MAXIMUM PERMISSIBLE EXPOSURE (MPE) LIMIT. IT IS THE RESPONSIBILITY OF THE BASE STATION OPERATOR TO ENSURE THAT THE MAXIMUM PERMISSIBLE EXPOSURE LIMITS ARE OBSERVED AT ALL TIMES DURING BASE STATION TRANSMISSION. THE BASE STATION OPERATOR IS TO ENSURE THAT NO BYSTANDERS ARE WITHIN THE RADIUS LIMITS.**

## 1.2 DETERMINING MPE RADIUS

**THE MAXIMUM PERMISSIBLE EXPOSURE RADIUS** is unique for each site and is determined at during site licensing time based on the complete installation environment (i.e.. co-location, antenna type, transmit power level, etc.). Determination of the MPE distance is the responsibility of the installation licensee. Calculation of the MPE radius is required as part of the site licensing procedure with the FCC.

## 1.3 SAFETY TRAINING INFORMATION



**YOUR M/A-COM MASTR III BASE STATION GENERATES RF ELECTROMAGNETIC ENERGY DURING TRANSMIT MODE. THIS BASE STATION IS DESIGNED FOR AND CLASSIFIED AS “OCCUPATIONAL USE ONLY” MEANING IT MUST BE USED ONLY IN THE COURSE OF EMPLOYMENT BY INDIVIDUALS AWARE OF THE HAZARDS OF RF ENERGY AND THE WAYS TO MINIMIZE EXPOSURE. THIS BASE STATION IS NOT INTENDED FOR USE BY THE “GENERAL POPULATION” IN AN UNCONTROLLED ENVIRONMENT. IT IS THE RESPONSIBILITY OF THE LISENSEE TO ENSURE THAT THE MAXIMUM PERMISSIBLE EXPOSURE LIMITS ARE OBSERVED AT ALL TIMES DURING TRANSMISSION. THE BASE STATION OPERATOR IS TO ENSURE THAT NO BYSTANDERS COME WITHIN THE RADIUS OF THE LIMITS.**

When licensed by the FCC, this base station complies with the FCC RF exposure limits when persons are beyond the MPE radius of the antenna. In addition, your M/A-COM base station installation complies with the following Standards and Guidelines with regard to RF energy and electromagnetic energy levels and evaluation of such levels for exposure to humans:

**FCC OET Bulletin 65 Edition 97-01 Supplement C, Evaluating Compliance with FCC Guidelines for Human Exposure to Radio Frequency Electromagnetic Fields.**

**American National Standards Institute (C95.1 – 1992), IEEE Standard for Safety Levels with Respect to Human Exposure to Radio Frequency Electromagnetic Fields, 3 kHz to 300 GHz.**

**American National Standards Institute (C95.3 – 1992), IEEE Recommended Practice for the Measurement of Potentially Hazardous Electromagnetic Fields – RF and Microwave.**



TO ENSURE THAT YOUR EXPOSURE TO RF ELECTROMAGNETIC ENERGY IS WITHIN THE FCC ALLOWABLE LIMITS FOR OCCUPATIONAL USE, **DO NOT** OPERATE THE BASE STATION IN A MANNER THAT WOULD CREATE AN MPE DISTANCE IN EXCESS OF THAT ALLOWABLE BY THE FCC.



## **1.4 IMPORTANT SAFETY INFORMATION**

The following general safety precautions must be observed during all phases of operation, service, and repair of this product. Failure to comply with these precautions or with specific warnings elsewhere in this manual violates safety standards of design, manufacture, and intended use of the product. M/A-COM Inc. assumes no liability for the customer's failure to comply with these standards.

**SAVE THIS MANUAL** - It contains important safety and operating instructions.

1. Before using this equipment, please follow and adhere to all warnings, safety and operating instructions located on the product and in the manual.
2. **DO NOT** expose equipment to rain, snow or other type of moisture.
3. Care should be taken so objects do not fall onto or liquids do not spill into the equipment.
4. **DO NOT** expose equipment to extreme temperatures.
5. **DO NOT** connect auxiliary equipment to the MASTR III System that is not recommended or sold by M/A-COM. To do so may result in the risk of fire, electric shock or injury to persons.
6. **GROUND THE EQUIPMENT** - To minimize shock hazard, the station equipment cabinet must be connected to an electrical ground.

If AC powered, the correct type of AC power cable and plug must be used. This cable and plug assembly must conform to local standards and the installation of power cords must conform to local standards and practices.

7. To reduce risk of damage to electrical cords, pull by plug rather than cord when disconnecting a unit.
8. Make sure all power cords are located so they will not be stepped on, tripped over, subjected to damage or stress, or located such that they may be hazardous to health.
9. An extension cord should not be used unless absolutely necessary. Use of an improper extension cord could result in a risk of fire or electric shock. If an extension cord must be used, ensure:
  - a) The extension conforms to local standards and practices,
  - b) The pins on the plug of the extension cord are the same number, size, and shape as those of the plug on the power supply,
  - c) The extension cord is properly wired, in good condition, and
  - d) The wire size is capable of handling the AC ampere rating of unit/s being supplied.
10. **DO NOT** operate equipment with damaged power cords or plugs - replace them immediately.
11. **DO NOT** attempt to operate this product in an explosive atmosphere unless it has been specifically certified for such operation.
12. To reduce risk of electric shock, isolate the unit and unplug from outlet before attempting any maintenance or cleaning.
13. **DO NOT** attempt to operate this product with covers or panels removed. Refer all servicing to qualified service personnel.
14. Use only fuses of the correct type, voltage rating and current rating as specified in the parts list. Failure to do so can result in fire hazard.
15. **GROUNDING AND AC POWER CORD CONNECTION** - To reduce risk of electrical shock use only a properly grounded outlet. The system components are equipped with electric cords having

equipment grounding conductors and a grounding plug. Be sure all outlets are properly installed and grounded in accordance with all local codes and ordinances.

16. **DANGER** - Never alter the AC cord or plug. Plug into an outlet properly wired by a qualified electrician. Improper connection or loss of ground connection can result in risk of an electrical shock.
17. **ELECTROSTATIC DISCHARGE SENSITIVE COMPONENTS** - This station contains CMOS and other circuit components that may be damaged by electrostatic discharge. Proper precaution must be taken when handling circuit modules. As a minimum, grounded wrist straps should be used at all times when handling circuit modules.

## 1.5 SAFETY SYMBOLS IN THIS DOCUMENT

The following conventions are used throughout this manual to alert the user to general safety precautions that must be observed during all phases of operation, service, and repair of this product. Failure to comply with these precautions or with specific warnings elsewhere in this manual violates safety standards of design, manufacture, and intended use of the product. M/A-COM, Inc. assumes no liability for the customer's failure to comply with these standards.



The **WARNING** symbol calls attention to a procedure, practice, or the like, which, if not correctly performed or adhered to, could result in personal injury. Do not proceed beyond a **WARNING** symbol until the conditions identified are fully understood or met.



The **CAUTION** symbol calls attention to an operating procedure, practice, or the like, which, if not performed correctly or adhered to, could result in damage to the equipment or severely degrade the equipment performance.



The **NOTE** symbol calls attention to supplemental information, which may improve system performance or clarify a process or procedure.



The **ESD** symbol calls attention to procedures, practices, or the like, which could expose equipment to the effects of **Electro-Static Discharge**. Proper precautions must be taken to prevent ESD when handling circuit modules.

## 2. SPECIFICATIONS (GENERAL)

### 2.1 CABINET

<b>Cabinet Size (H x W x D):</b>		<b>Total Rack Capacity</b>
37-Inch Cabinet (37 x 21-1/2 x 18-1/4), (940 x 550 x 460 mm)		17
69-Inch Cabinet (69 x 23-3/16 x 21), (1750 x 590 x 533 mm)		33
83-Inch Cabinet (83 x 22-1/2 x 20-1/4), (2108 x 571 x 514 mm)		41
<b>Weight (minimum)</b>	<b>Continuous Duty</b>	<b>Packed, Domestic Shipping</b>
37-Inch Cabinet	150 lbs (68 kg)	165 lbs (75 kg)
69-Inch Cabinet (w/3 repeaters)	520 lbs (236 kg)	550 lbs (250 kg)
83-Inch Cabinet (w/3 repeaters)	550 lbs (250 kg)	580 lbs (263 kg)
<b>Options</b>		<b>Required Rack Units</b>
MASTR III Base Station & Power Supply		8
Auxiliary receivers (1 or 2 receivers)		4
Battery Shelf and Batteries (CH1R)		6
Duplexers (factory installed) (DU1J, DU1K, DU1M)		3
Receiver Voting Selector		4
Aegis™/Voice Guard® Shelf (VG3E, VG3F)		1
Aegis Voice Guard Module and Shelf (VV1N, VW1J, VG3D, VV1S)		

1 Rack Unit = 1.75-inches

### 2.2 STATION

	Basic station occupies 8 RU (includes T/R Shelf, PA, & Power. Supply)
<b>Service Speaker:</b>	1 watt at 8 ohms
<b>Service Microphone:</b>	Transistorized Dynamic
<b>Duty Cycle (EIA) Continuous:</b>	Transmit and Receive at 100%
<b>Operating Temperature:</b>	-22° to +140°F (-30°C to +60°C)
<b>Humidity (EIA):</b>	90% at 122°F (50°C)
<b>Input Power Source:</b>	5 Amps at 120 VAC (±20%) 60 Hz or 3 Amps at 230 VAC (±15%) 50 Hz

**DC Input Power:**

With 19D902797 Power Amplifier:	33 Amps at 13.8 VDC (transmit, full power)
	25 Amps at 13.8 VDC (transmit, half power)
	2.0 Amps at 13.8 VDC (receive only, standby)
With EA101292 Power Amplifier:	12 Amps at 26.4 VDC (transmit, full power)
	8 Amps at 26.4VDC (transmit, half power)
	0.5 Amps at 26.4 VDC (receive only, standby)

**Antenna Connection:**

Type N

**Altitude:**

Operating:	Up to 15,000 ft (4,570 m)
Shippable:	Up to 50,000 ft (15,250 m)

## 2.3 INTERFACE

**Line Interface**

Line Interface	2-wire or 4-wire ( <i>programmable</i> )
Line Cancellation	(2-wire) 20 dB amplitude only ( <i>programmable</i> )

**Audio (line to transmitter)**

Line Terminating Impedance	600 ohms (2-wire or 4-wire)
Line Input Level (adjustable)	-20 dBm to +7 dBm
Frequency Response	±3 dB @ 300 to 3000 Hz

**Remote Tone Control**

Function Tones (Hz):	1050, 1150, 1250, 1350, 1450, 1550, 1650, 1750, 1850, 1950, & 2050
Secur-it Tone and Transmit Tone	2175 Hz
Permissible Control Line loss @ 2175 Hz:	30 dB

**Audio (receiver to line)**

Output Impedance to Line	600 ohms (2-wire or 4-wire)
Output Level to Line (adjustable):	Zero to +7 dBm (Reference at 1 kHz)
Frequency Response	+1 and -3 dB @ 300 to 3000 Hz
Hum and Noise, Noise Squelch:	-55 dBm (Reference 7 dBm)
Tone Squelch:	-30 dBm (Reference 7 dBm)

**DC Remote Control Currents:**

	-2.5 mA, ±6.0 mA, ±11.0 mA
Line Loop Resistance (maximum)	11K ohms (includes 3K ohm termination)

### 3. INTRODUCTION

This manual describes how to install, setup, and test the MASTR<sup>®</sup> III Advanced Digital Capable (ADC) Base Station configured for Conventional or P25 operation. Before attempting to install or checkout the equipment, you should become familiar with the contents of this manual and observe all safety precautions and warnings.

This manual is used with the MASTR III Conventional and P25 Application and Assembly Diagrams Manual MM102555V1. The Application and Assembly Diagrams manual includes specific application information, cable diagrams, and parts lists for the cabinet hardware. The installer should consult the Application and Assembly Diagrams manual when installing and cabling the base station and for detailed instructions for installing options and accessories.

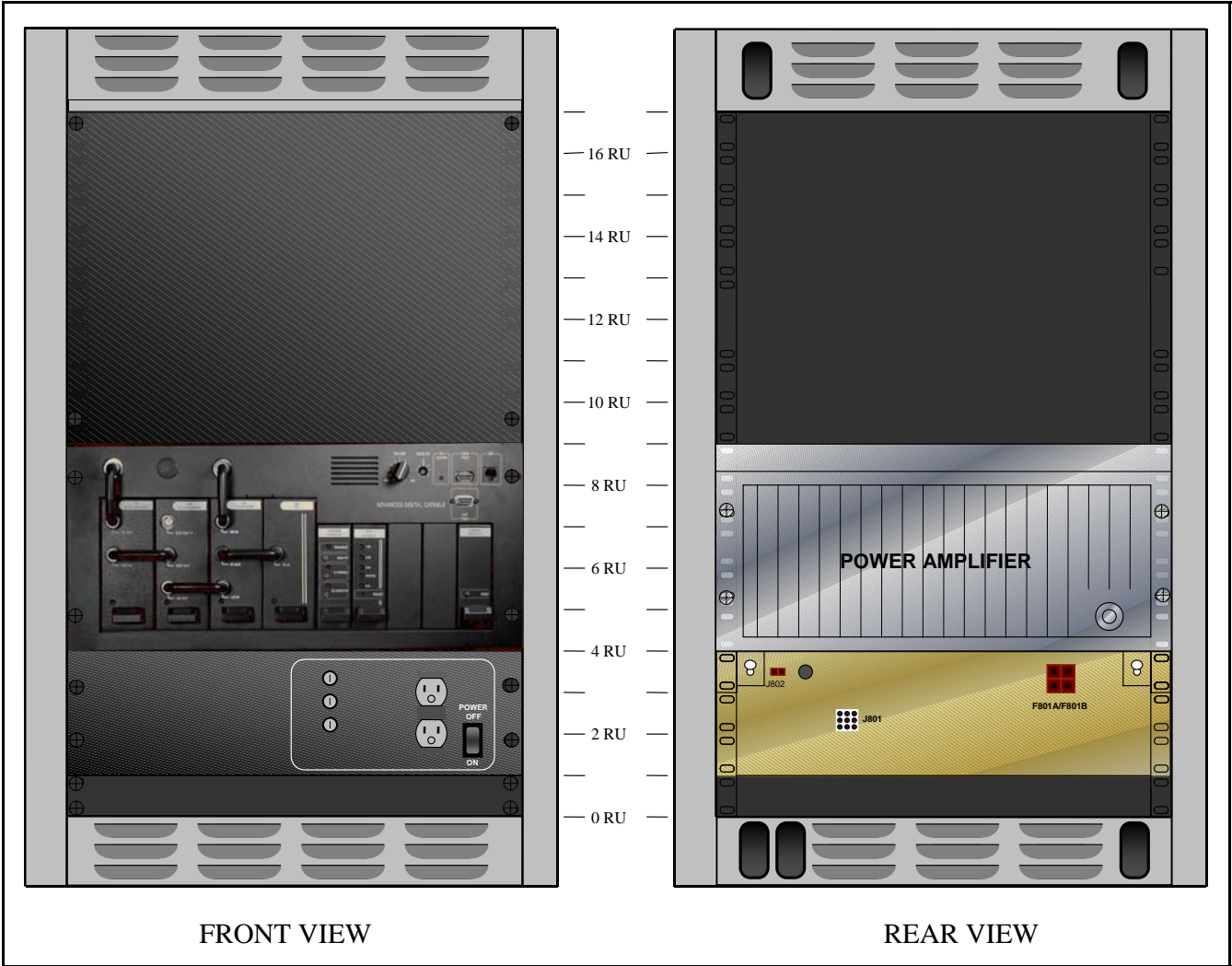

Figure 3-1: Single Channel MASTR III ADC Conventional Base Station in 37" Cabinet

This manual is divided into the following chapters:

1. **Regulatory and Safety Information** – This chapter provides critical safety information governing the installation and operation of the base station.
2. **Specifications** – This chapter provides the specifications for a typical conventional base station installed in a 37" or 69" cabinet.
3. **Introduction** - This chapter provides a brief introduction on how this manual is structured.
4. **General Information** – This chapter lists many of the options and other technical manuals, which may affect the installation of this base station.
5. **Site Preparation** - This chapter identifies site requirements and installation practices for the antenna tower, transmission lines, and the equipment shelter.
6. **Equipment Installation** - This chapter provides instructions for unpacking and physically installing the electronic equipment cabinets.
7. **DC and Tone Remote Control Installation** – This chapter provides information for configuring the base station for operation with a DC or Tone Remote Control system.
8. **Base Station Test and Alignment Procedures** – This chapter provides detailed instructions for testing and aligning each of the individual system components.
9. **System Functional Tests** - This chapter provides detailed instructions for verifying the overall operation of the equipment as a system.
10. **Module Testing and Alignment** - This chapter provides details for bench testing or aligning individual modules or testing and aligning the modules “in-station.” It also provides procedures for changing the base station frequency.
11. **Preventative Maintenance** - This chapter defines those tests to be performed as part of Periodic Preventative Maintenance.
12. **Checklists** – This chapter includes support features, such as Installation and Preventative Maintenance Checklists.

## 4. GENERAL INFORMATION

### 4.1 REFERENCE MANUALS

It may be necessary to consult one or more of the following manuals. These manuals will also provide additional guidance if you encounter technical difficulties during the installation or testing process.

DESCRIPTION	MANUAL NUMBER
<b>OVERVIEW MANUALS</b>	
MASTR III Conventional ADC Base Station	MM102558V1
MASTR III P25 Conventional ADC Base Station	MM102559V1
<b>MASTR III CONVENTIONAL &amp; P25 INSTALLATION MANUAL</b>	MM102554V1
MASTR III Conventional & P25 Application and Assembly Diagrams	MM102555V1
<b>MASTR III ADC T/R SHELF</b>	MM102244V1
System Module (19D902590G6)	LBI-39176
Power Module (19D902589G2)	LBI-38752
<b>DSP MODULE (EA101800V1)</b>	MM101943V1
<b>DATA MODULE (19D904558G1)</b>	LBI-38918
<b>MASTR III RF PACKAGE: VHF (136 - 174 MHZ)</b>	MM102557V1
Transmit Synthesizer Module (19D902780G1)	LBI-38640
Receive Synthesizer Module (19D902781G1)	LBI-38641
Receiver Front End Module (19D902782G1)	LBI-38642
Receiver IF Module (EA101401V1)	MM101886V1
Power Amplifier (EA101292V10, V11, & V12)	MM101383V2
<b>MASTR III RF PACKAGE: UHF (380 - 512 MHZ)</b>	MM102557V2
Transmit Synthesizer Module (19D902780G3, G6-G10)	LBI-38671
Receive Synthesizer Module (19D902781G3)	LBI-38672
Receiver Front End Module (19D902782G11)	LBI-39129
Receiver IF Module (19D902783G11)	LBI-39123
Power Amplifier (19D902797G11)	LBI-38674
<b>MASTR III RF PACKAGE: 800 MHz</b>	LBI-39025
Transmit Synthesizer Module (19D902780G5)	LBI-39026
Receive Synthesizer Module (19D902781G5)	LBI-39027
Receiver Front End Module (19D902782G5)	LBI-39028

<b>DESCRIPTION</b>	<b>MANUAL NUMBER</b>
Receiver IF Module (19D902783G5)	LBI-39029
Power Amplifier, 110 Watt (EA101292V1)	MM101383V1
<b>OPTIONS AND ACCESSORIES</b>	
Electrostatic Discharge Protection	LBI-38737
Antenna Systems Assembly Manual	LBI-38983
Standard for Site Grounding and Protection	LBI-39067
Duplexer Maintenance Manual	LBI-38763
Base Station Power Supply Maintenance Manual (19D149978)	LBI-38550
Base Station Power Supply Maintenance Manual (19D149979)	LBI-38551
Emergency Power (Battery Charger) Maintenance Manual	LBI-38625
AC Outlet Strip Maintenance Manual	LBI-4841
Blower Kit Maintenance Manual	LBI-4842
MASTR III Fuse Panel (12/24 Volt) Maintenance Manual	LBI-30246
GETC Trunking Shelf Installation and Configuration Manual	AE/LZB 119 2905/1
MASTR III Back-to-Back Repeater Configuration Manual	LBI-39118
Conventional MASTR III Voice Guard Options Installation Manual	AE/LZB 119 2905/2
Voice Guard System Manual	LBI-31600
Voice Guard Interface Board Maintenance Manual	LBI-38882
<b>TEST AND DIAGNOSTICS</b>	
RF Module Test Fixture (TQ0650) - Model 344A4153P1 - Model TS101285V11	LBI 38805 MM101885V1
MASTR IIe Utility Handset Manual	LBI-38599
MASTR III Programming Guide TQS3353	MM102518V1
MASTR III DSP Module Programming Guide TQS3413	MM102533V1



## 4.2 OPTIONS

The MASTR III Conventional Base Station is available in the following frequencies and may be combined with the options listed.

MODEL NUMBER	DESCRIPTION
SXGPNX	136-150.8 MHZ, CONVENTIONAL ADVANCED DIGITAL CAPABLE (ADC) P25, 110W
SXHPNX	150.8-174 MHZ, CONVENTIONAL ADVANCED DIGITAL CAPABLE (ADC) P25, 110W
SXGMCX	136-150.8 MHZ, CONVENTIONAL ADVANCED DIGITAL CAPABLE (ADC), 110W
SXHMCX	150.8-174 MHZ, CONVENTIONAL ADVANCED DIGITAL CAPABLE (ADC), 110W
SXRM CX	403-425 MHZ, CONVENTIONAL ADVANCED DIGITAL CAPABLE (ADC), 90W
SXPM CX	410-430 MHZ, CONVENTIONAL ADVANCED DIGITAL CAPABLE (ADC), 90W
SXTM CX	425-450 MHZ, CONVENTIONAL ADVANCED DIGITAL CAPABLE (ADC), 90W
SXUM CX	450-470 MHZ, CONVENTIONAL ADVANCED DIGITAL CAPABLE (ADC), 100W
SXVM CX	470-494 MHZ, CONVENTIONAL ADVANCED DIGITAL CAPABLE (ADC), 90W
SXWM CX	492-512 MHZ, CONVENTIONAL ADVANCED DIGITAL CAPABLE (ADC), 90W
SX8M CX	800 MHZ, CONVENTIONAL ADVANCED DIGITAL CAPABLE (ADC), 100W
<b>OTHER OPTIONS</b>	
<b>CABINETS &amp; FANS</b>	
SXCA1D	69" CABINET
SXCA1U	83" CABINET
SXCA1S	37" CABINET
SXMR1D	86" OPEN RACK
SXCA1X	45" OUTDOOR CABINET
SXFN1A	2-SPD FAN, 120 VAC. (Must be included when installing more than 1 repeater in a 69" or 83" cabinet)
SXFA1L	2-SPD FAN, 230 VAC. (Must be included when installing more than 1 repeater in a 69" or 83" cabinet)
SXFA1N	2-SPD FAN, 12 VDC. (Must be included when installing more than 1 repeater in a 69" or 83" cabinet)

MODEL NUMBER	DESCRIPTION
<b>POWER SUPPLIES</b>	
SXPS5G	POWER SUPPLY, 120 VAC, 60 HZ, 12 VDC, 33A. For UHF applications.
SXPS5H	POWER SUPPLY, 230 VAC, 50 HZ, 12 VDC, 33A. For UHF applications.
SXPS5S	POWER SUPPLY, 120 VAC, 60 HZ, 12/24 VDC, 33A. For 800 MHz and VHF applications
SXPS5Y	POWER SUPPLY, 230 VAC, 50 HZ, 12/24 VDC, 33A. For 800 MHz and VHF applications
SXCN1Z	OUTLET STRIP. 120 VAC
SXCN3H	OUTLET STRIP, 230 VAC
<b>PROGRAMMING</b>	
TQS3353	MASTR IIE/MIII PROGRAMMING SOFTWARE, Provides capability of changing radio's functions and features. Includes TQ0619 Utility Programming Software.
TQ0653	MASTR IIE/MASTR III MSEDIT SOFTWARE
SPK9024	UTILITY HANDSET
TQS3413	DSP MODULE PROGRAMMING SOFTWARE
TQ3356	MASTR IIE/MIII PROGRAMMING CABLE

## 5. SITE PREPARATION

### 5.1 INTRODUCTION

Before you install a MASTR III ADC Base Station, you need to prepare your site. Consider the installation of the antenna system, space requirements, and weight. These issues are addressed in this chapter.

This chapter is divided into the following sub-sections:

- Facility Preparation
- Power Installation
- Inter-Site Communication
- Protective Grounding
- Antenna System
- Power Up Sequence

### 5.2 FACILITY PREPARATION

This section provides information for preparing the facility prior to receiving or installing the MASTR III ADC Base Station equipment.

#### 5.2.1 Floor Plan

When creating the floor plan for cabinet placement, ensure consideration is given to safety, lighting, fire suppression systems, access to other equipment and storage facilities in the room, etc.

#### 5.2.2 Equipment Cabinet Placement

Direct access (for antenna cables and personnel) between the tower and the equipment room is necessary for installation purposes).

The equipment cabinet you plan to install should be in an area that is:

- A dedicated equipment room or closet, wired in accordance with local electrical codes
- Large enough to allow easy access for service and maintenance
- Free of dust, smoke, and electrostatic discharge
- Properly ventilated
- Well lighted



#### NOTE

The recommended aisle spacing is 29.5 in. (750 mm).

### **5.2.3 Ceiling Requirements**

Consider the following ceiling requirements before you install the equipment cabinet:

- The ceiling should be clear of obstructions such as beams, heating and air conditioning ducts, water pipes, and lights.
- The ceiling should not have sprinklers; however, appropriate fire protection devices should be available.

### **5.2.4 Size and Weight Considerations**

Before you install the equipment at your site, make sure that the equipment room can accommodate the size and weight of the cabinet and the MASTR III ADC Base Station. To determine the total weight, add the weight of the radio system (about 150 lbs, 68 kg for each radio system), and the weight of the rack.

Typical equipment size and weight is listed in the Specifications section. For the specific weight of individual units or optional equipment, you should refer to the applicable maintenance manuals or product Data Sheets.

### **5.2.5 Operating Environment**

The equipment room or area where the MASTR III ADC Base Station is installed must meet the environmental conditions listed in the Station Specifications section of this manual. In addition, the site grounding must conform to the requirements of the Standards for Site Grounding and Protection manual AE/LZT 123 4618/1.

Although the temperature requirements for individual components may be broader, when several units are assembled together in a cabinet more heat is generated. Because of this condition, the ambient room temperature outside the cabinet must be lowered to ensure the temperature inside the cabinet does not exceed the limits for the equipment.

## **5.3 POWER INSTALLATION**

In all cases where the customer provides a single AC supply input to a site, for AC or DC systems, the input must be protected with a Joselyn AC protector, or equivalent. The AC Protector is installed after the disconnect switch and must be connected to the external ground system.

If the AC supply is provided from wall outlets, the fuse panel breaker for the room must be sized for the load of the proposed equipment that is to be installed in the site.

### **5.3.1 Existing Input Power**

If the site already has an existing input power source, then the installers and a certified electrician should ensure the power meets site requirements and is equipped with the necessary breakers to conform to both design and local regulatory standards.

If the site input power source does not meet the site requirements or is not equipped with the necessary breakers to conform to both design and local regulatory standards, refer the matter to the Site Manager.

### **5.3.2 AC Distribution**

If the site requires an AC distribution system to be installed, ensure it installed by qualified installers in agreement with the customer. The Applications Engineer will provide the Site Manager with drawings containing the installation requirements.

Ensure the input supply is isolated and power is not applied until the installation is complete.

### **5.3.3 Generator System**

If the system already has a backup generator system providing backup supply to the site, inspect and test the generator as defined in the equipment manuals.

Sites equipped with generator systems will use a manual or an automatic transfer switch system. Inspect the customer system to ensure that it is fitted with the appropriate transfer switch system. This is to be inspected and tested as defined in the equipment manuals.

If a new generator system is being installed, ensure it is installed by qualified generator installers in agreement with the customer. When installing generator system remote controls, ensure that the installer thoroughly understands the application and necessary generator connections. The Applications Engineer will provide the Site Manager with drawings containing the installation requirements.

#### **5.3.3.1 Manual Transfer Switch**

If a Manual Transfer Switch is to be installed, the same team who installed the generator should install the transfer switch. If this is an additional or new feature, the system is to be modified by qualified engineers in agreement with the customer. The Applications Engineer will provide the Site Manager with drawings containing the installation requirements.

#### **5.3.3.2 Automatic Transfer Switch**

If an Automatic Transfer Switch is to be installed, the same team who installed the generator should install the transfer switch. If this is an additional or new feature, the system is to be modified by qualified engineers in agreement with the customer. The Applications Engineer will provide the Site Manager with drawings containing the installation requirements.

### **5.3.4 AC-DC Supply**

If the system already has an AC-DC conversion system that meets the system requirements, then inspect and test the system as defined in the equipment manuals.

If the site requires an AC-DC conversion system to be installed, this is to be performed by qualified installers in agreement with the customer. The Applications Engineer will provide the Site Manager with drawings containing the installation requirements.

The system will normally include input circuit breakers, a rectifier stage, converters and individual output circuit breakers. These components will have their voltage and/or current specified on the site design drawings. Ensure that input supply is isolated and not re-apply power until installation is complete.

### **5.3.5 Battery Backup**

A Battery backup system is normally installed to ensure smooth supply voltages during normal operation or in the event of an input power failure.

If the site already has a battery backup system that meets the system's requirements, then inspect and test as defined in the equipment manuals.

The battery backup system will normally be a battery cell system. The backup battery system capacity should be sufficient to provide the radio system with the desired voltage for a specified time. This should also include power needed for the inverter equipment, input and output breakers, and either manual or automatic switches to switch the system into circuit. The installation requirements will be in the site design drawings agreed to by the customer and Application Engineer.

### **5.3.6 UPS**

An Uninterruptible Power Supply (UPS) system may be an alternative to other backup supply options. It may comprise some or all of the following components:

- Input supply and protection
- Various DC outputs (additional equipment that is required)
- Output protection
- Battery backup
- Bypass switch
- Automatic switch-over to generator

If the site already has an UPS system that meets the system requirements, then inspect and test the UPS as defined in the equipment manuals.

If the site requires an UPS system to be installed, ensure the installation is made by a qualified installer in agreement with the customer. The Applications Engineer will provide the Site Manager with drawings containing the installation requirements.

### **5.3.7 Electrical Power**

#### **5.3.7.1 AC Power**

Each MASTR III cabinet is equipped with its own AC power cord. Each of these power cords should be connected to a separate circuit breaker. The following circuit breakers are recommended.

- 115 VAC (60 Hz) - a 20-amp circuit breaker for each power cord.
- 230 VAC (50 Hz) - a 15-amp circuit breaker for each power cord.

Receptacles must be installed within reach of the power cords and should be individually fused. They may be installed on the wall behind the cabinets, in the floor under the cabinets, on the cable ladder above the cabinets, or in the cabinet top cable ducts. The power cords must not be installed such that they cause a hazard to persons in the site.

AC Power Installation must conform to local Installation Regulations.

### **5.3.7.2 DC Power**

When required, DC power options are available, but will be customized for the particular system. The power supplies will be omitted from the cabinets and replaced by a fused DC panel. In this case, power must be supplied to the repeaters from an external 13.8 or 24 VDC power source through a separate 30-amp circuit breaker for each repeater.

The supply system will normally consist of an AC to DC converter, a Circuit Breaker Panel and various DC-DC Converters sized for the equipment. DC feeds to the equipment that will be direct from the circuit breaker panel.

### **5.3.7.3 Generators**

Some systems, predominately remote sites, will require emergency generators with automatic switchover systems. The generators must be connected to the external site grounding system and should be located external to the equipment room.

Automatic switchover systems must be disabled during installation.

### **5.3.7.4 Battery Backup**

Some systems will require a battery backup connected to the supply system in case of input power failure. The battery bank should be located either separate from the equipment room or within the room but at a point furthest from the entrance. It should have a separate fume extraction system or should be located below the air extraction system for the site.

## **5.4 INTER-SITE COMMUNICATIONS**

There are various types of Inter-Site Communication Systems, which require interfaces to be pre-installed within the site. These interfaces will be the agreed demarcation points to which the Customer, Sub-Contractor and system installer will make connections.

There are three types of inter-site connections:

- **Hardwire Installation**
  - Direct Connection
- **Leased Line**
  - Leased or Dedicated Telephone Line
- **T1 or E1**
  - Leased T1 or E1
  - Microwave
  - Fiber Optic Cable

### **5.4.1 Hardwire Installation**

When the media specified is to be Hardwire, that is point-to-point wiring on-site, the following specifications apply:

- Audio: 2-wire or 4-wire shielded cable; screen connected to site ground system and cable core is to be solid in order that it may be punched-down.
- Data: Shielded twisted pair, shield connected to site ground system and cable core is to be solid in order that it may be punched-down.

#### **5.4.2 Leased Telephone Lines**

When the media specified is to be Leased-Line via the local telephone company, request a 4-Wire 43202 Type 5 Data-Grade line from the local or regional telephone carrier. If using an equivalent line (old specification is 3002 Data Grade), it must meet the following specifications:

- Frequency response:

1000 Hz	Reference
500 - 2400 Hz	-1 to +3 dB
300 - 2700 Hz	-2 to +6 dB
- Max Frequency Error =  $\pm 5$  Hz
- Max Net Loss = 16 dB
- Max Group Delay (800-2400Hz) = 2000 $\mu$ S
- Min S/N Ratio = 24 dB

The Telephone Company or customer will provide a point of interface for the telephone system within the site known as the Demarcation Point. The installer will make necessary connections between the Demarcation Point and the equipment

#### **5.4.3 T1 or E1 Links**

A T1 or E1 link may be leased from the Local or Regional Telephone Carrier. The physical link may be via a Microwave System or via Fiber Optic cable. The Microwave or Fiber Optic system may also be provided by the customer or sub-contracted from an alternate provider.

##### **5.4.3.1 Leased T1/E1**

If the link is Leased-Line T1 or E1, the carrier may provide the Multiplex (Mux) equipment and Channel Service Unit (CSU). If so, they will connect to an agreed Demarcation Point (Punchblock) and collect the data and modem audio as appropriate. If they do not provide the Mux or CSU, a Mux and CSU will be provided and the demarcation point will be the appropriate T1/E1 interface on the Mux or CSU.

##### **5.4.3.2 Microwave**

The Microwave system may be provided by the Customer, M/A-COM, or a Sub-Contractor. Whichever is the case, the Inter-Site Communications System should be in place prior to equipment installation and the system provided will have a Demarcation Point to which the installer will connect the Inter-Site Communications. This may be Punchblocks or the input connection to the multiplexer and the length of the cross-connect cabling must be calculated to allow for the agreed location of the interface.

It is normal for the microwave radio to be close to its antenna and, in some installations, this may mean some distance between radio and multiplexer. If the distance between radio and multiplex equipment is excessive, consideration must be given to type of cable used for the connection, cable shield/ground,



grounding through in-building cable routes, etc. This subject is to be discussed with microwave provider and must conform to local installation regulations.

#### **5.4.3.3 Fiber Optic**

It is a requirement that the demarcation point for fiber optic cable is the fiber optic interface on the multiplexer. If the multiplexer is not equipped with such an interface, a fiber optic line driver will be provided and will be the point to which the cable is to be connected.

All other considerations are as for Microwave.

## **5.5 PROTECTIVE GROUNDING**

For information on protective grounding outside the equipment room and general information for internal grounding refer to the Site Grounding and Lightning Protection Standard manual AE/LZT123 4618/1.

However, a general rule for the external grounding system is that the resistance to ground should be five (5) ohms or less, as measured with a Biddle DET2/2 Megger or equivalent, per IEEE STD 81-1983 or local equivalent.

All equipment that is within the site must be connected to an internal halo ground of No. 2 AWG copper wire six (6) inches below the ceiling. This interior halo ground must be connected to the external ground system at each corner, using separate No. 2 AWG copper wires. The halo may be mounted on the cable ladder, in the ducting or beneath the false floor.

All metal (electrically conductive) objects within the equipment room must be grounded. These objects are divided into the following three (3) groups.

- Room Fixtures
- Power Supply
- RF equipment

All metallic fixtures and room parts, such as doorframes, sheet metal, ventilation louvers, air conditioning units, light fixtures, etc., should be connected to the internal halo ground.

In addition to all other AC power protection, the AC power must be equipped with a Jocelyn AC protector, or equivalent, placed immediately after the main disconnect switch. This protector must be connected to the external ground system using a separate No. 2 AWG copper wire.

All equipment cabinets, cable trays, and protectors for cables connecting to this equipment must be connected to a single grounding plate or bulkhead panel mounted on the wall where the antenna cables enter the equipment room. This grounding plate must be connected to the external ground system using two (2), two-inch wide copper strapping, or equivalent. A separate No. 6 AWG copper wire must be used for each cabinet, each cable tray/ladder, and each group of cable protectors.

A few general rules of thumb are as follows:

- Make ground wires as short as possible and direct as possible - avoid bends if possible - absolutely no bends with a radius of less than eight (8) inches.
- Surface area of ground wires is more important than cross sectional area.
- All connections must be clean, free of non-conductive coatings, and be coated with an anti-oxidant.

## 5.6 ANTENNA SYSTEM

This section covers installing the antenna system, including RF cables from the antenna to the equipment room wall feed through connector.



### NOTE

Refer to LBI-39185 for Tower Requirements and General Specifications.

Crews trained and equipped for working on antenna towers generally install antenna systems. As a result, this manual assumes crews with the specialized equipment and skills required for working on towers and installing the antenna cables will install the Antenna Systems. However, it may be necessary for the system installer to provide information and directions to the crew installing the antenna system and to verify proper installation.

### 5.6.1 Antenna Mounting

The antennas must be installed on the tower in such a way as to ensure that there is at least 25 dB of separation between the TX and RX antennas. This is necessary to avoid interference in the receivers caused by the transmitters. An isolation of greater than 25 dB is easily obtained by placing one antenna directly above the other on the tower (minimum 10-foot separation).

# ANTENNA SYSTEM REQUIREMENTS

To supplement the manufacturer's instructions, the following hints will be valuable to you when installing your antenna.

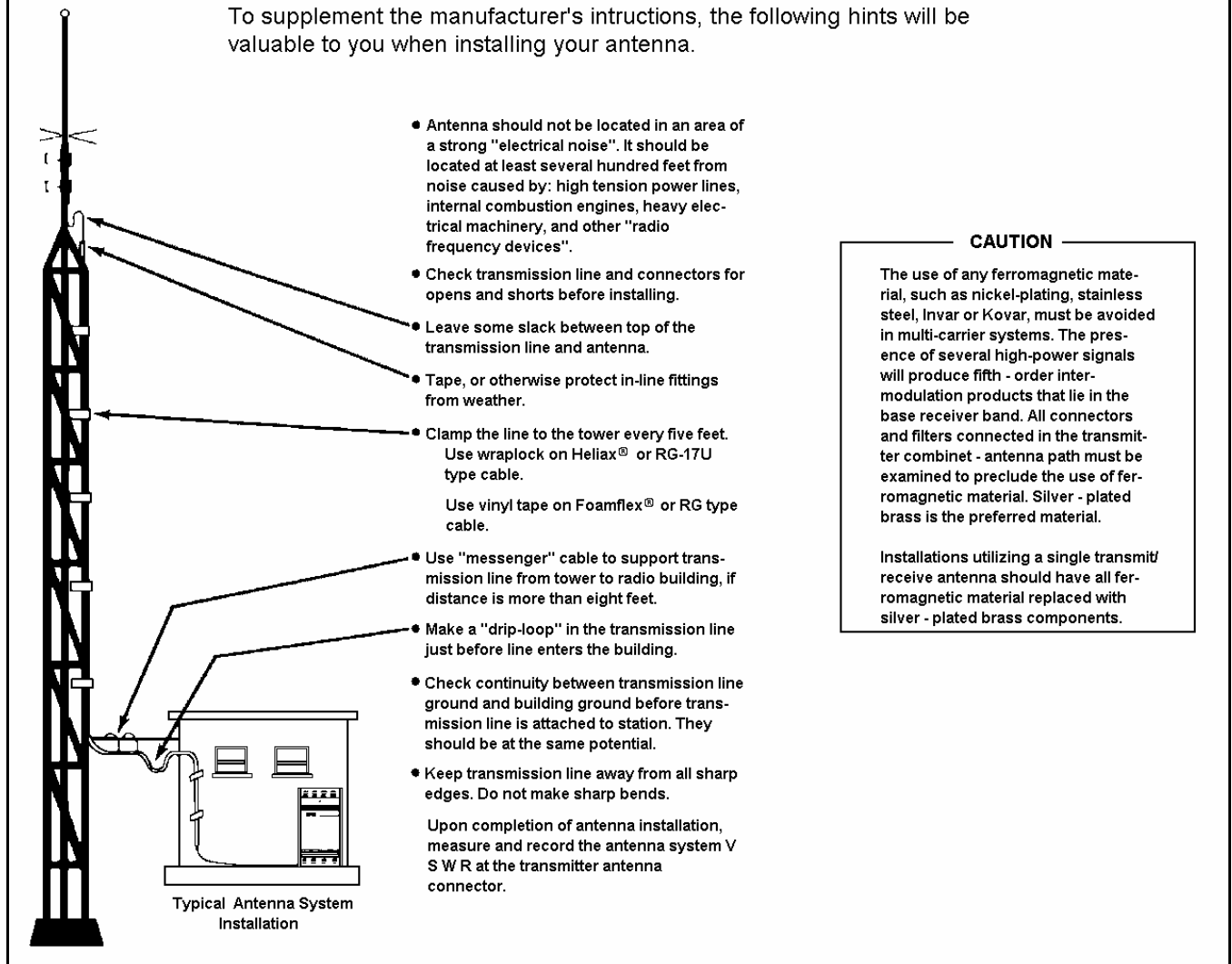

Figure 5-1: Antenna System Requirements

## 5.6.2 Transmission Lines

When installing the transmissions lines, refer to the block diagram for UHF and 800 MHz Antenna Systems contained in LBI- 38983.

### 5.6.2.1 Length

The length of the main coaxial cable for each antenna should be planned as a continuous run with no connectors or splices between the antenna and the equipment room. Each cable includes a 50-foot allowance for the distance from the bottom of the tower to the equipment room. Smaller diameter, more flexible coaxial cables are used at both ends of the main coaxial cable to facilitate installation.

### 5.6.2.2 Minimum Bending Radius

Always adhere to the minimum bending requirements provided by the manufacturer. For Andrew Products, the values are:

CABLE SIZE	BENDING RADIUS
1/4-inch	1-inch (25 mm)
1/2-inch	1.25-inch (32 mm)
7/8-inch	10-inches (250 mm)
1 5/8-inch	20-inches (510 mm)

### 5.6.2.3 Hoisting Grips

Hoisting grips provide the means to attach a lifting mechanism to the coaxial cable without damaging the cable. Each hoisting grip is capable of safely lifting 200 feet of cable without causing damage. Therefore, one hoisting grip is required for every 200-foot section of cable. The grips may be left attached to the cable after the cable installation is completed.

Some situations may require more hoisting grips, such as:

- When installing cables on a tower mounted on top of another structure.
- When installing a cable whose length is greater than the height of the tower.

In these situations, additional hoisting grips should be ordered.

### 5.6.2.4 Hangers and Adapters

Coaxial cables on the tower should be secured at intervals of 3-5 feet (maximum).

Securing 7/8-inch and 1-5/8-inch diameter coaxial cables is accomplished by using either hangers or hanger-adapter combinations. The hangers secure the cables to the tower structure by using prepunched holes or attachment adapters.

- When the tower structure is prepunched with 3/4-inch holes, snap-in hangers are used (preferred method).
- When the tower is prepunched with 3/8-inch holes, the hanger is secured by a 3/8-inch bolt.

For towers without prepunched holes, the hangers are attached with adapters. The type of adapter depends on the type of tower structure. Adapters are available for either angle tower members or round tower members.

Adapters for each antenna system are selected when ordering the system. If the coaxial cable must be attached to a structure that is not compatible with any of the above hangers or adapters, then additional materials or other special considerations may be required.

To secure 1/4-inch or 1/2-inch vertical or horizontal coaxial cables of any size, use nylon cable ties.

### **5.6.2.5 Weatherproofing**

A kit of weatherproof tape is provided to protect coaxial connectors from the outside elements. One roll of tape is sufficient to weatherproof four exposed outside connector joints.

## **5.7 QUALITY AUDIT**

### **5.7.1 Antenna System**

After the Antenna System is installed, it should be inspected before the installers leave. A checklist of tasks performed on the antenna system is provided in section 12.3. Be sure to complete this visual inspection before the installers leave, so any obvious errors can be corrected.

Using field glasses, if necessary, view the Antenna System from various positions on the ground. Using copies of the Antenna System Installation Checklist 12.3, fill out a checklist for each antenna as you go through the following inspection procedure. This will provide a record of the inspection, and of some antenna information for future reference.

- Record the make of antenna.
- Record the type of antenna (omni or directional).
- Record the design gain of the antenna.
- If the antenna is directional, record the bearing of the main lobe. If it is omni, write "Omni" in the data entry line.
- Record the height of the antenna above ground.
- Confirm that cable-hoisting grips were installed as required to prevent damage to the coaxial cable. Hoisting grips should have been installed at the antenna end of the cable plus one for each 200 feet of cable length.
- Confirm the cable is secured to the tower at intervals, which do not exceed 3 feet.
- Confirm the cable is grounded at the top of the tower.
- Confirm the cable is grounded at the point where it leaves the tower.
- Confirm the cable is grounded at the point where it enters the building.
- Confirm the coaxial cable run looks OK. The cable must be tight (nothing to flap in the breeze), have no kinks, is one continuous run (no connectors or splices), and not exceed the minimum-bending radius on any bend.
- Confirm the cable feed through is properly installed where the cable enters the building.
- Confirm the coaxial connectors have been properly weather sealed with tape.
- Confirm the cable entrance to the building has been properly weather sealed.

### **5.7.2 Electrical System**

If the electrical supply system has been installed by other than the company, it must be inspected to ensure that it is safe and complies with both local regulations and the requirements of the site. Complete the Power System Installation Checklist found in section 12.5, as required.

- Confirm that the supply system is rated to handle the full operating load of the equipment.
- Confirm that all outputs to which the site equipment will be connected have suitably rated breakers installed.
- Confirm that electrical cabling to the equipment is correctly rated, installed and meets local regulations.
- Confirm that the system is correctly grounded.
- Confirm that cables, bus bars and associated equipment are not a hazard to installers or maintenance teams.
- Confirm that manuals for the supply system have been provided at the site.

## 6. EQUIPMENT INSTALLATION

### 6.1 INTRODUCTION



#### NOTE

AC power adequate to meet system requirements, environmental control, civil works and site preparation, and digital or voice grade phone lines must be available at the site prior to installation.



#### DO NOT apply power at this time!

During installation, all circuit breakers must be left in the OPEN position. Make sure all equipment circuit breakers are in the OPEN position.

To prevent damage to equipment, ensure power is not accidentally applied at this time.

This chapter is divided into the following sub-sections:

- Unpacking the Equipment
- Equipment Installation
- Interior RF Cabling
- Connecting Electrical Power
- Quality Audit

### 6.2 UNPACKING EQUIPMENT

Station equipment is generally packed in one of the following ways:

- Bolted vertically to a mini pallet approximately 36" deep x 32" wide, with a corrugated cardboard cover held down with two plastic straps. This technique is generally used for domestic shipments. The mini pallet adds approximately three inches to the overall cabinet height. The weight varies according to the content, but generally runs from 300 pounds to 600 pounds.
- Crated vertically or horizontally. This technique is generally used for open-racked equipment and overseas shipments of 69-inch and 83-inch cabinets. Crates may contain one or several cabinets or racks, and the dimensions and weight will vary accordingly. If size and weight limits are required, contact the factory for special packing instructions.

Cabinets packed on mini pallets can be moved with a hand-truck, crates may need a forklift or pallet jack, depending on the size. Wrenches will be needed to unbolt the cabinets from the mini pallets, and a crowbar and hammer will be useful in opening the crates. Do not leave packed or unpacked equipment exposed to the weather.

Upon receipt of the station equipment, carefully examine each carton. If any packaging damage is detected, note the damage on the Bill of Lading.

Move the cartons as close as possible to their mounting location.

Carefully unpack the equipment and examine each item. If there is any damage to the equipment, contact the carrier immediately and have their representative verify the damage. If you fail to report the shipping damage immediately, you may forfeit any claim against the carrier.

When unpacking the equipment, check the contents against the packing list. Contact your M/A-COM representative and the carrier if any discrepancies are noted.

Carefully open each cabinet and inspect the contents to ensure that enclosed equipment has not been damaged during delivery. If damage has occurred, note details of the damage and, if necessary, contact the carrier immediately and have their representative verify the damage. Contact your M/A-COM representative if the damage is such that installation cannot proceed.

### 6.3 EQUIPMENT INSTALLATION



**NOTE**

Refer to AE/LZT 123 4618/1 for Site Grounding and Protection Standards.



**NOTE**

These procedures are for M/A-COM standard installations. If the system is non-standard, installation procedures may differ. In this event, installers should consult with M/A-COM.

- This section provides instructions for installing the RF Equipment and for running the necessary RF cables to the equipment room wall TX and RX feed through connectors.

#### 6.3.1 Mounting Vendor Supplied RF Equipment

RF Equipment used for interfacing the Antenna System to the Repeaters may be pre-racked by M/A-COM or dropped shipped from the individual vendors directly to the customer. If the RF equipment is supplied directly from the vendor, it will be necessary to install the equipment into the RF Equipment Cabinet.



**NOTE**

The system is designed to use either a Tower Top Amplifier or a Receiver Filter. When a Tower Top Amplifier is used, the Receiver Filter is not required.



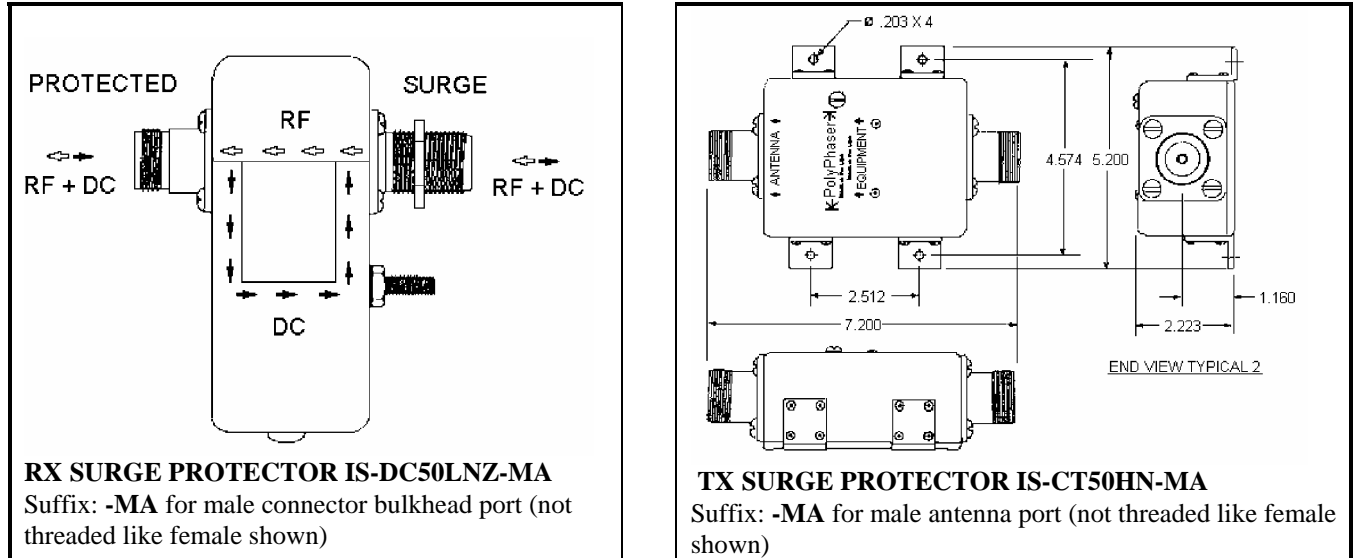

Figure 6-1: Surge Protectors

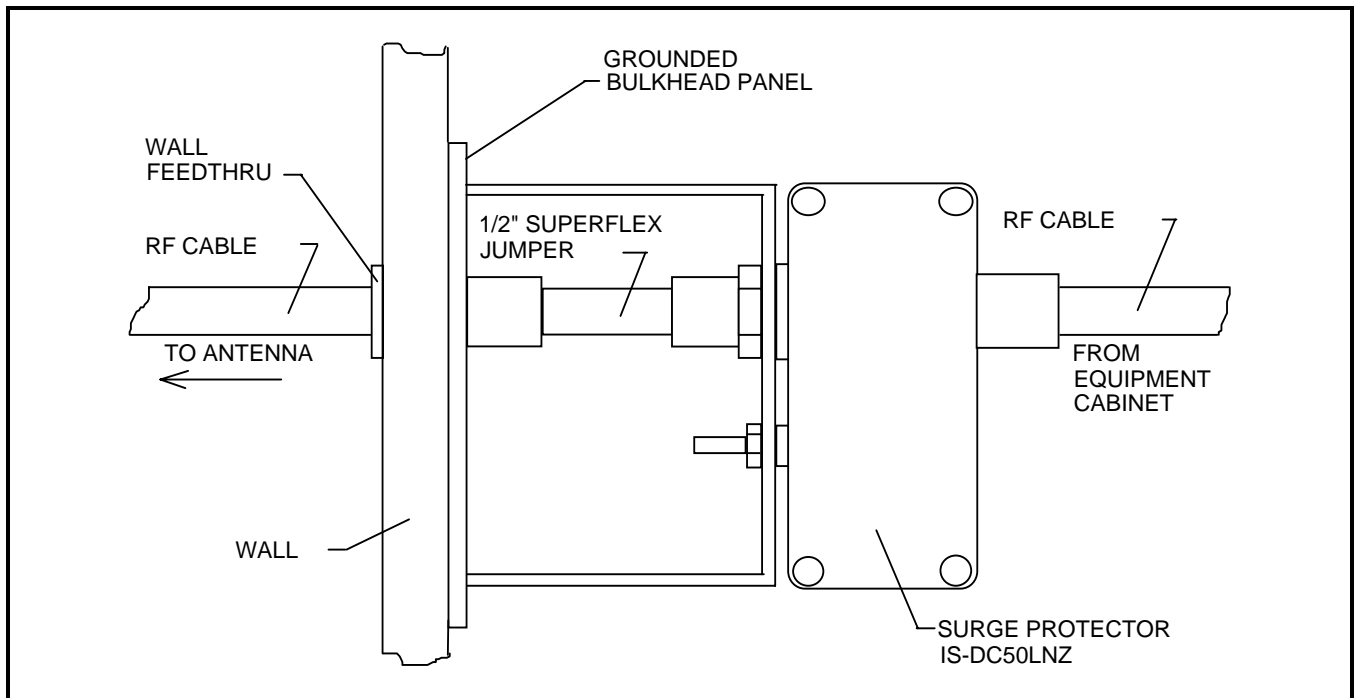

Figure 6-2: Typical Mounting of the RX Surge Protectors

1. Install the vendor supplied RF equipment into the RF Equipment cabinet.
2. Secure each component to the cabinet using standard mounting screws and clips that come as part of the cabinet hardware kit.
3. Mount the Receive Surge Protector (IS-DC50LNZ-MA), if not previously installed, to the grounded bulkhead panel, located at the wall feed thru where the antenna system enters the building. Other installers (refer to Surge Protector Diagrams in Figure 6-1 and Figure 6-2) should have already installed this panel.

4. Mount the transmit surge protector (IS-CT50LNZ-MA) to the grounded bulkhead panel, located at the wall feed through where the antenna system enters the building. Installers should have already installed this panel. (Refer to Surge Protector Diagrams in Figure 6-1 and Figure 6-2)
5. Install Top Cover (if cabinet).

### **6.3.2 Mounting Base Station Cabinet (Typical)**

The following tools and materials are typically needed to fasten the cabinets to concrete floor (if installing on wood flooring - do not use lead anchors):

- 1/2" x 2" Lag screws (4 per rack)
- 1/2" Flat washers (4 per cabinet/rack)
- Lead anchor for 1/2" lag screws (4 per rack)
- Measuring tape
- Heavy-duty marker (suitable for marking coarse concrete)
- Eye protection
- Ear protection
- Drill with masonry bit (see size marked on anchor)
- 1/4" x 24" Flexible plastic tubing (blow debris out of hole)
- Hammer (seat anchor in hole)
- Wrench (screw lag screw into anchor)

The following additional hardware is supplied with each optional open-rack. The hardware enables the installer to fasten adjacent side rails together at the top and bottom:

- 3/8" x 1 1/2" Hex machine screws (2 per open-rack)
- 3/8" Hex nut (2 per open-rack)
- 3/8" Flat washers (4 per open-rack)
- 3/8" Lock washer (2 per open-rack)

The RF Equipment cabinet(s) should be located at a point nearest the RF Bulkhead, where the antenna cables enter the building. This allows the antenna cable lengths to be minimized.

Position the cabinet(s) on the floor exactly where they are to be mounted. Allow one (1) meter (3 feet) of free space in front of and behind each cabinet, to allow the cabinet doors to swing completely open. Also allow one (1) meter (3 feet) of free space around at least one end of each row of cabinets, to get to the back of the cabinets.

Mark the position of the mounting bolt holes on the floor using the four holes in the bottom of each cabinet as a template. Move the cabinets, drill the holes in the floor for the screw anchors, seat the anchors in the holes, reposition the cabinets, and fasten the cabinets down with lag screws (use a flat washer under each lag screw head, to prevent damage to the cabinet).

## 6.4 INTERIOR RF CABLING

Some RF coaxial cables may be pre-made and included with the system. However, most cables must be custom made, on site, to the required length. Table 6-1 lists the cables and associated connectors, which are typically fabricated at the site.

The coaxial cable and connectors are supplied in bulk. To cut the cable properly for easy connector attachment, use an Andrew's "EASIA" coaxial cable cutting tool (or equivalent).

**NOTE**

When installing the RF or power cables, refer to the Antenna System Block Diagrams in LBI-38983 and the Application Assembly Diagrams in technical manual MM102556V1 for in installation instructions.

### 6.4.1 Cable Routing

If cabinet-top cable ducts are supplied, install per LBI-38875 using the hardware provided. However, leave the duct covers off until the site wiring is complete. These cable ducts are not available for open-type equipment racks.

Larger systems should make use of cable ladders for ease of installation and maintenance. It is preferable that dual ladders be used for large systems such that audio and data may occupy one level of the ladder and RF and power occupy the other. If dual systems are not available, ensure maximum separation between Audio/Data runs and RF/Power runs.

Install as shown on the site plans and install all grounding leads across ladder section connections.

### 6.4.2 Install RF Cables

Assemble and install the RF coaxial cables. Be careful not to exceed minimum bend radius (refer to Site Preparation - Antenna System for specifications).

Refer to the Antenna Systems Assembly Manual LBI-38983 and applicable vendor manuals for TX and RX connection points. (For specially engineered systems, refer to the Site Antenna System drawings for the site.)

Use cable ties to secure the coaxial cables to the back rails of the cabinets. Ensure cables do not impede access to the internal equipment and the installation appears neat and orderly. Exercise caution and ensure cables are routed away from the sharp ends of mounting screws (on the backside of the equipment rails). Allow room for equipment mounting screws to be removed and re-installed without damaging the cables.

**NOTE**

If overhead cable ladders are used, ensure the RF cable are of sufficient length to run from point A to point B via the cable ladder. Do not loosely 'drape' cables on the top of cable ladders or racks.

Begin the cable installation by installing receiver cables first. Then complete the installation by installing the transmitter cables.

**Table 6-1: RF Cables and Connectors Required**

CABLE REF. NUMBER	CABLE DESCRIPTION	CABLE TYPE	CONNECTORS
1.	RX RF coaxial cables. (Connects between the RX Multicoupler and Receiver RF inputs.)	[V] 1/4-inch Superflex RF coaxial cable (FSJ1-50A).	[U] Type N (M) - 41ASWB 1/4-inch Superflex connector.  [W] Type N (M) - 41ASW 1/4-inch Superflex connector.
2.	RX RF coaxial cable. (Connects between the RX Multicoupler and the Tower Top Amplifier Power Supply/RX Filter.)	[M] 1/2-inch Superflex RF coaxial cable (FSJ4 -50B).	[L] Type N (M) - 44ASW 1/2-inch Superflex connectors (qty. 2).
3.	TX RF coaxial cables. (These cables connect between the transmitter outputs and the TX Combiner.)	[M] 1/2-inch Superflex RF coaxial cable (FSJ4 -50B)	[L] Type N (M) - 44ASW Superflex connector.  [Y] Type N (M) - 49600-1, 1/2-inch Superflex right angle connector.
4.	RX RF coaxial cables. (Connects between the RX Tower Top Amplifier Power Supply and the RX surge protector.)	[M] 1/2-inch Superflex RF coaxial cable (FSJ4 -50B)	[L] Type N (M) - 44ASW 1/2-inch Superflex connectors (qty. 2).
5.	TX RF coaxial cables. (Connects between the Antenna Power Sensor and the TX surge protector.)	[M] 1/2-inch Superflex RF coaxial cable (FSJ4 -50B)	[L] Type N (M) - 44ASW 1/2-inch Superflex connectors (qty. 2).
6.	TX RF coaxial cables. (Connects between the Surge Protector and the wall feedthrough connector.)	[M] 1/2-inch Superflex RF coaxial cable (FSJ4 -50B)	[L] Type N (M) - 44ASW 1/2-inch Superflex connectors.  [N] Type N (F) - 44ASN 1/2-inch Superflex connectors.
[ ] – References in brackets refer to material callouts in the Antenna Systems manual LBI-38983.			

### 6.4.2.1 Receive Section

Use the following procedures to install the RF cables for the receive section of the system. Refer to LBI-38983 and Table 6-1 for cable references.

1. Route receiver RF cables (item 1) from the RX Multicoupler to the receiver RF input connectors. One cable is required for each receive channel as labeled (RX CH 1, RX CH 2, RX CH 3, etc.).



#### NOTE

These cables may be connected inside the repeater cabinets at the factory. If they are already connected to the repeaters, they only need to be routed to the RX Multicoupler. Pay close attention to cable labeling and connect to the correct port on the Multicoupler.

2. Make sure any unused ports on the RX Multicoupler are terminated with 50-ohm loads (refer to the vendor Maintenance Manual).
3. Connect a 1/2-inch Superflex RF cable (item 2) from the input of the RX Multicoupler to the output of the Tower Top Amplifier Power Supply (or RX Filter, if installed).
4. Connect a 1/2-inch Superflex RF jumper from the surge protector to a wall feedthrough.
5. Connect a 1/2-inch Superflex RF cable (item 4) from the output of the Tower Top Amplifier Power Supply (or RX Filter) to the receive surge protector.
6. Connect the Tower Top Amplifier Power Supply and the RX Multicoupler to the appropriate supply source or power strip. (Ensure the circuit breaker is OFF prior to plugging cord into power source.)

### 6.4.2.2 Transmit Section

Use the following procedures to install the RF cables for the transmit section of the system. Refer to LBI-38983 and Table 6-1 for cable references.

1. Route the TX RF (1/2-inch Superflex) cables (item 3) from the power output connector of each transmitter to the RF Equipment Cabinet/rack.
2. Connect each TX RF (item 3) cable to the TX Combiner input corresponding to the channel number as labeled (TX CH1, TX CH2, TX CH3, etc.).
3. To make any other required connections to the TX Combiner, refer to Installation & Operation Manual supplied by vendor.
4. Connect the TX Combiner channels as instructed in the vendor manual.
5. Connect a 1/2-inch Superflex RF jumper (item 6) from the surge protector to the Bulkhead Panel.
6. Connect a 1/2-inch Superflex RF cable (item 5) from the TX Combiner - RF Power Sensor (if supplied) output to the TX surge protector.

## 6.5 CONNECTING ELECTRICAL POWER

The site, regardless of complexity of equipment, is to be powered-up in a controlled fashion. This is to ensure that, should a power problem occur, possible damage can be limited and the problem can be quickly located and resolved. In general, a site is to be powered-up with all breakers open and site equipment that is isolated. Breakers will be closed in a logical progression through the power system until it can be applied direct to the site equipment. Annotate findings on the Electrical Power Checklist.

### **6.5.1 AC Power Distribution**

Before connecting power to the base station equipment, perform the following tests to ensure correct voltage levels and breaker operation.

1. Visually inspect the power distribution panel and note any discrepancies.
2. Test the input supply and confirm that the input supply can provide the correct voltage and current.
3. Visually inspect the breakers on the input to the site. Confirm that they are rated as required for the site loading. The requirement is stated in the site survey requirements document.
4. Confirm that the power cabling is sufficient for the expected load.
5. Confirm operation of input AC protection breaker.
6. Close each breaker in turn to provide AC power to individual equipment.
7. If the breakers are fitted with an over voltage test facility, perform the test once an equipment has been powered up.
8. Confirm that each station or cabinet supply is operating correctly and that output voltages are as required.

### **6.5.2 Generator Backup**

If the generator system has remote control or alarms to be connected to the site equipment, ensure these are connected prior to test. Also ensure that the fuel system is ready for operation and that the system is correctly grounded.

1. Switch the generator on.
2. Confirm output supply is as specified in the drawings.
3. If remote control option is installed, remotely control the operation of the generator.
4. If alarms are configured, toggle the alarm conditions and confirm that the alarm system correctly reports the conditions.

### **6.5.3 AC-DC Supply**

Ensure that each converter output breaker to the equipment is open.

1. Confirm operation of input AC protection breaker.
2. Confirm that the rectifier output is at the desired voltage.
3. Confirm that the rectifier output breaker operates.
4. With converter output breakers open, confirm each converter output is as rated.
5. Close each breaker in turn to provide DC power to individual equipment.
6. Confirm that each station or cabinet supply is operating correctly and that output voltages are as required.

### **6.5.4 Battery Backup**

Prior to powering on the site, it is essential to inspect the battery system and confirm that the installation is safe, that the connectivity is correct, that the cells are serviceable and that the installation conforms to regulatory and site requirements.

1. Confirm that the battery system connectivity is correct as detailed in the Site Drawings.
2. Confirm the battery system is electrically safe.
3. Confirm that “wet” cells have been prepared and have adequate fume extraction capability provided.
4. Confirm that all cabling is safely installed such that it is not a hazard.
5. Confirm that output voltage is as specified across all the cells.
6. With site equipment breakers disconnected, connect the battery system to the site power system.
7. Confirm that the battery system is in Charge mode.
8. Confirm that the power system is providing power to the open site equipment breakers by checking voltage across breakers.
9. Close the Repeater Cabinet #1 equipment breakers to connect power to that cabinet only. Confirm that equipment powers up correctly and that there are no abnormal indications.
10. Confirm that battery power has been applied to site equipment power distribution equipment.
11. Confirm that the battery supply applied on site equipment is as specified.
12. When the battery cell system has fully charged, disconnect the AC input to the site by opening the site supply protection breaker.
13. Confirm that the battery supply can provide power to the site equipment as required.

#### **6.5.5     UPS**

Follow the instructions in the UPS installation manual and test the operation of the UPS. Ensure the UPS can provide power to the site equipment as required.

### **6.6    POWER-UP SEQUENCE**

Open all site equipment power distribution breakers or power down station or cabinet power supplies.

1. Close customer power breaker to apply power into site power system. Confirm that input power is at rated voltage and that there are no abnormal indications.
2. If the system is fitted with auxiliary or backup power systems, connect these to the power system. Check backup power is at the rated voltage, is correctly applied to the main power source equipment that is either in normal or emergency modes and that there are no abnormal indications.
3. If the system provides DC to the site, connect the power source to the converters. Check the outputs of each converter and confirm that the output is as designed and rated for the equipment.
4. Apply power to each repeater, or to the repeater cabinet, if power is not provided individually to each station. Switch the repeaters on, one-by-one. Confirm that there are no abnormal indications.
5. Apply power to the any ancillary cabinets on site and confirm that there are no abnormal indications.

## **7. DC AND TONE REMOTE CONTROL INSTALLATION**

This chapter provides information for connecting a DC or Tone Remote Control system to the base station.

The DC Current or Tone Signaling Remote controllers available from M/A-COM are full-function controllers used to operate the base station from a remote location. The DC Current Remote Controller can control and display up to four channels, and the Tone Remote Controller can control and display up to eight channels. Parallel controllers can receive indications of transmit and remote selections. In addition, 10 or more dispatch points (remote controllers) can operate a single base station.

Wiring between a remote controller and the base station is usually made using direct wire lines or leased telephone lines. This wiring may also be used in conjunction with a Multiplex or Microwave system.

### **7.1 DC REMOTE INSTALLATION**

The MASTR III Conventional ADC Base Station can be remotely controlled by DC control currents. A DC remote control unit can initiate a transmission, listen to received audio, and select or deselect certain base station functions. Control current signaling from a DC remote control unit consists of applying different current levels on a wire pair having DC continuity. The six control current levels used for controlling the base station are:

- -11 milliamperes
- -6 milliamperes
- -2.5 milliamperes
- 0 milliamperes
- +6 milliamperes
- +11 milliamperes

The following station functions can be controlled by using control currents:

- Repeater Disable
- Channel Guard Monitor
- Transmit Frequency Selection
- Receive Frequency Selection
- Scan
- Receiver Selection (Auxiliary Receiver selection)

Table 7-1 is a list of DC Control Currents and their corresponding functions.

#### **7.1.1 Wiring Methods for DC Remote**

DC Remote Control units can be connected to the base station in one of four connection schemes. The choice of which installation method should be used is based on the cost, availability, and performance as compared to controller's operating environment.

Table 7-2 provides a description of the four methods and gives some of the advantages and disadvantages of each method. After the table, installation procedures are available for each method. The procedures contain detailed wiring instructions. These instructions assume a M/A-COM DC Remote Control unit is being connected to the base station.



Table 7-1: DC Control Currents and Functions

FUNCTION	CONTROL CURRENT IN MILLIAMPS					
	-11	-6	-2.5	0	+6	+11
1 FREQ TX 1 FREQ RX				RECEIVE	TRANSMIT	
2 FREQ TX 2 FREQ RX		RX-F2		RX-F1	TX-F1	TX-F2
2 FREQ TX 2 FREQ RX WITH SCAN	RX-F2	RX-F1		SCAN	TX-F1	TX-F2
1 FREQ TX 1 FREQ RX WITH CHANNEL GUARD DISABLE			CG DISABLE	RECEIVE WITH CG	TRANSMIT	
2 FREQ TX 2 FREQ RX WITH CHANNEL GUARD DISABLE	RX-F2 CG DISABLE	RX-F2 WITH CG	RX-F1 CG DISABLE	RX-F1 WITH CG	TX-F1	TX-F2
REPEATER DISABLE		REPEATER DISABLE		RECEIVE	TRANSMIT	
REPEATER DISABLE & CHANNEL GUARD DISABLE	REPEATER DISABLE & CG DISABLE	REPEATER DISABLE	CG DISABLE	RECEIVE WITH CG	TRANSMIT	
1 FREQ TX 2 SEPARATE RECEIVERS (AUX RX)	RX-F2	RX-F1		RX-F1 & RX-F2	TRANSMIT	
2 FREQ TX 2 SEPARATE RECEIVERS (AUX RX)	RX-F2	RX-F1		RX-F1 & RX-F2	TX-F1	TX-F2

Table 7-2: DC Remote Wire Line Installation Methods

METHOD	DESCRIPTION	ADVANTAGES OR DISADVANTAGES
1	Single metallic pair (the control currents are simplex to line, a two wire cable is required).	This is the most economical method. It is dependable where earth ground currents may be large or good earth grounds cannot be obtained. The keying clicks will be heard on paralleled remotes.
2	Single metallic pair (the control currents are simplex line to earth ground, a two wire cable is required).	This method is also economical. It minimizes keying clicks in paralleled remotes. Large ground currents may result in interference with control functions if remotes are located near sub-stations.
3	Two wire pairs needed. One is a voice grade pair for bidirectional audio and the other is a metallic pair used for control current.	Provides excellent performance by eliminating keying clicks and providing no path for ground loop current. However, it does require two wire pairs.
4	Two wire pairs needed. One is a voice grade pair for receive audio. The second is a metallic pair for transmit audio and control Currents.	Provides full duplex operation in which the remote can receive and transmit at the same time. However, it does require two wire pairs.

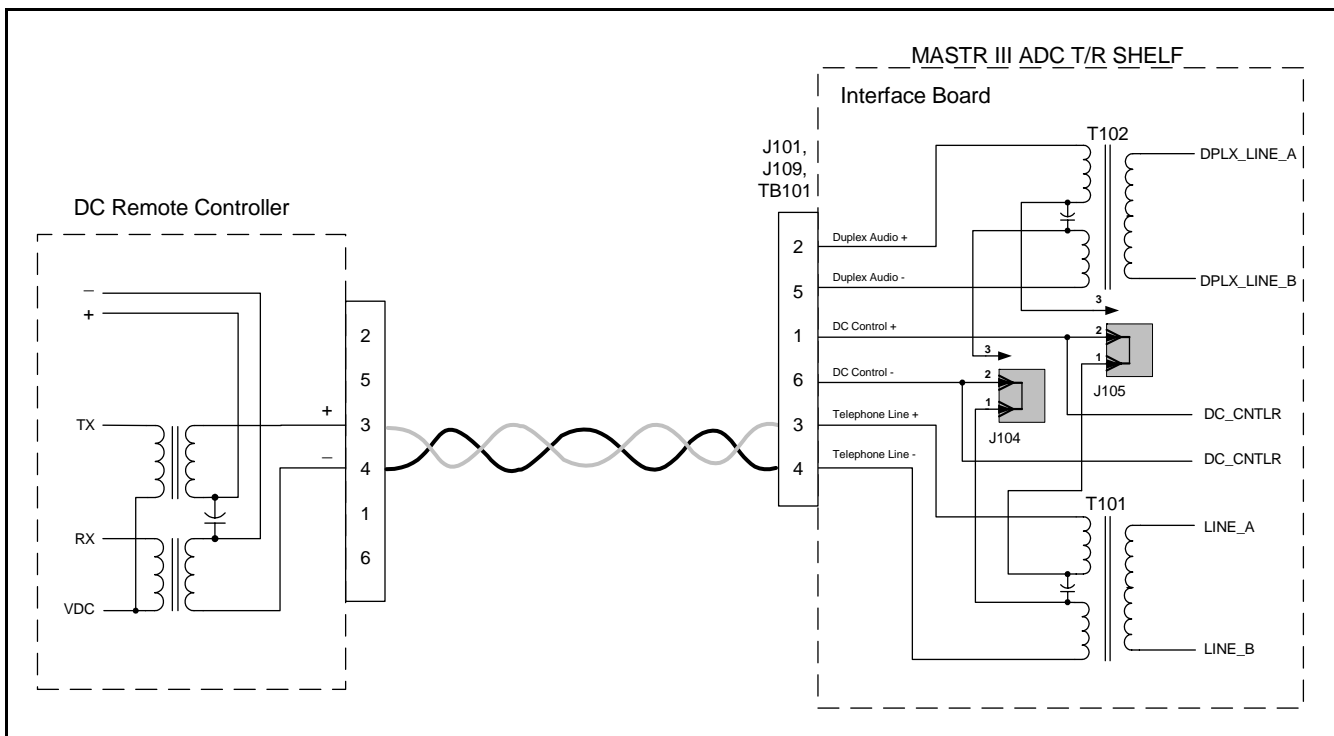

Figure 7-1: Method 1 – Single Metallic Pair

### 7.1.2 Installation Method 1 – Single Metallic Pair

1. Connect the metallic pair to TB101-3 (red) and TB101-4 (green). Refer to Figure 7-1.
2. On the Interface Board, place a jumper on J104, pins 1 & 2 and on J105, pins 1 & 2.



NOTE

Polarity must be maintained, if the metallic control pair is being used for DC control.

### 7.1.3 Installation Method 2 – Single Metallic Pair with Earth Ground

1. Connect the metallic pair to TB101-3 (red) and TB101-4 (green). Refer to Figure 7-2.
2. On the Interface Board, place a jumper on J104, pins 1 & 2 and on J105, pins 1 & 2.
3. Connect a wire between TB101-6 and earth ground.

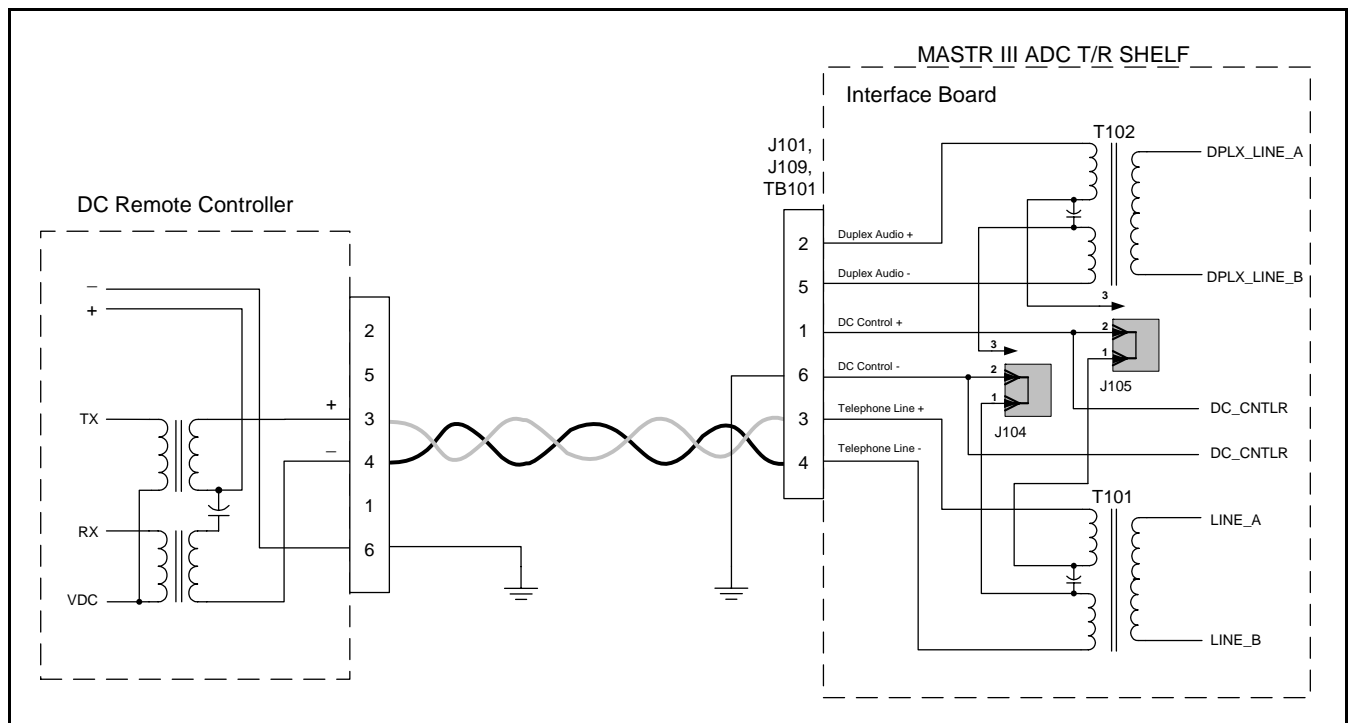

Figure 7-2: Single Metallic Pair with Earth Ground

### 7.1.4 Installation Method 3 - Metallic Control Pair, Audio Pair

1. Connect the audio pair to TB101-3 (red) and TB101-4 (green). Refer to Figure 7-3.
2. On the Interface Board, remove jumpers from J104 and J105.
3. Connect the control metallic pair to TB101-1 (white) and TB101-6 (blue).

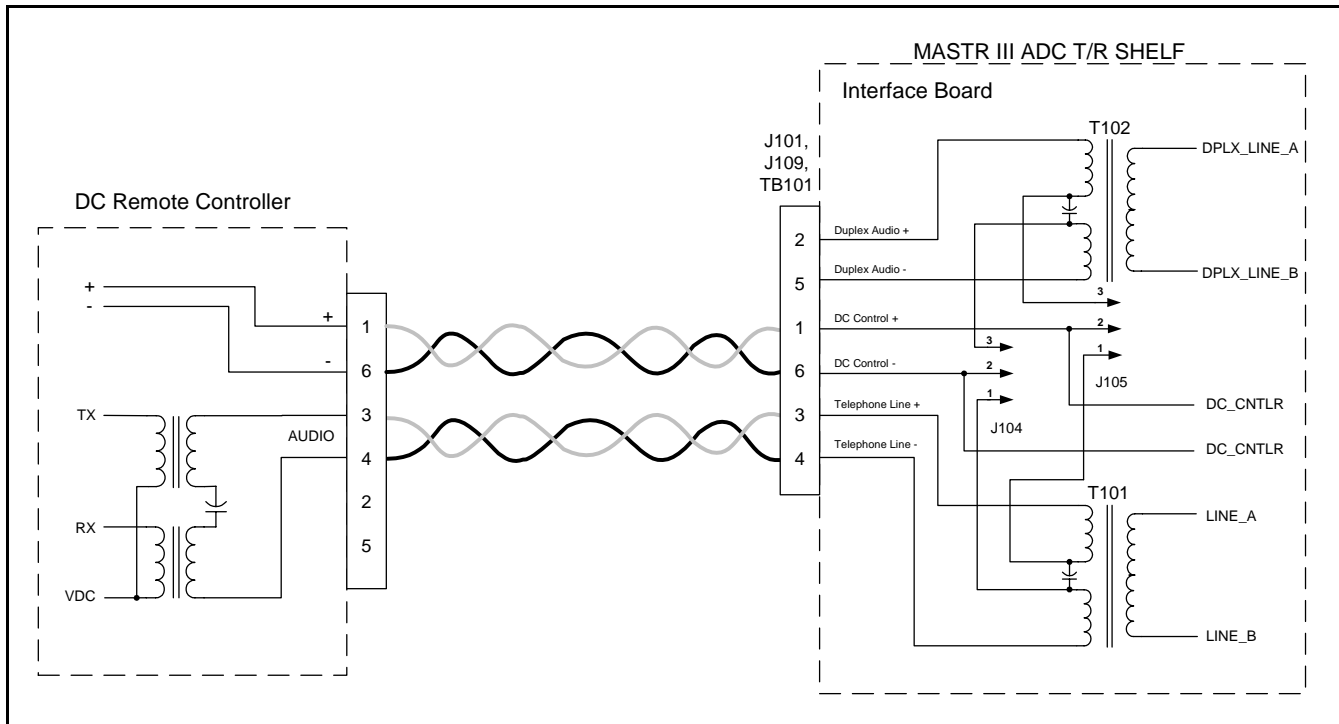

Figure 7-3: Metallic Control Pair, Audio Pair

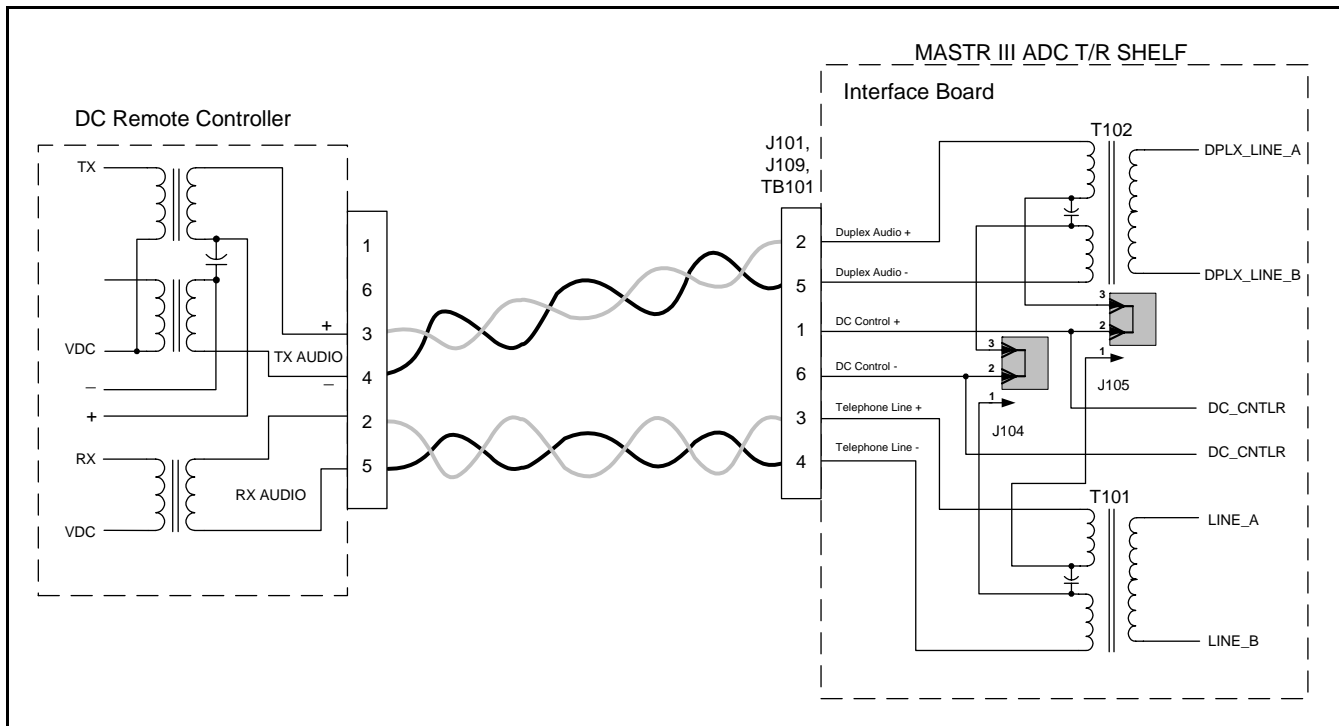

Figure 7-4: Method 4 – Full Duplex

### 7.1.5 Installation Method 4 - Full Duplex

1. On the Interface Board, place a jumper on J104, pins 3 & 4 and on J105, pins 3 & 4.
2. Connect the transmit metallic pair to TB101-2 (black) and TB101-5 (yellow). Refer to Figure 7-4.
3. Connect the remote receive pair to TB101-3 (red) and TB101-4 (green).

## 7.2 E & M SIGNALING

E & M lead signaling systems derive their name from certain historical designations of the signaling leads on circuit drawings. An “**M**” lead is associated with the trans**M**it function or **M**outh, while the “**E**” lead is associated with the rec**E**ive function or **E**ar. In some two-way radio systems with remote control, E & M Signaling may be the only type of control offered by the available carrier circuits.

Generally, both 4-Wire Audio and E & M Signaling options are used to interface between the radio and carrier systems. However, 2-Wire Audio can be used in the two-way radio portion of the control system if hybrids are installed to provide transition between the 2-Wire and 4-Wire connections. Usually the E & M Signaling is separated from the audio (separate line) in both 2-Wire and 4-Wire installations.

### 7.2.1 Standard (Type II) E & M Signaling

The Standard or Type II E & M (+48 V) signaling method uses four wires for signaling, the “E” pair at the Remote Control Console and the “M” pair at the base station. This configuration uses four wires for audio. One voice grade pair is used for TX audio and the other pair is used for RX audio. This is illustrated in Figure 7-5, which also shows the interface between a two-way radio system and a multiplex/microwave system.

At the console a regulated -48 VDC output (or -24 VDC with minor modifications) is applied to the “M” lead when the TRANSMIT switch is pressed. This -48 VDC activates a tone encoder (usually 3825 Hz) in the multiplex rack. The tone encoder modulates the carrier frequency, which is transmitted over the microwave link.

At the station end of the microwave link, the signal is demodulated and the 3825 Hz tone operates a tone decoder in the multiplex rack. The output of the decoder results in a contact closure, which applies +48 VDC (or +24 VDC) to the DC control lines on T/R Shelf. The DC Current Detection Circuit detects the presence of the +48 V signaling as a +11mA current. The station then executes a “Channel 1 – Remote PTT” which then keys the transmitter and routes the audio from the Line Input to the transmitter.

#### 7.2.1.1 Installation

1. Connect the E & M control lines to TB101 pins 1 and 6.
2. Connect the remote control transmit pair (which modulates the transmitter) to TB101-2 and -5.
3. Connect the remote control receive pair (which listens to the receiver) to TB101-3 and TB101-4.
4. Remove jumpers from J104 and J105 on the Interface Board

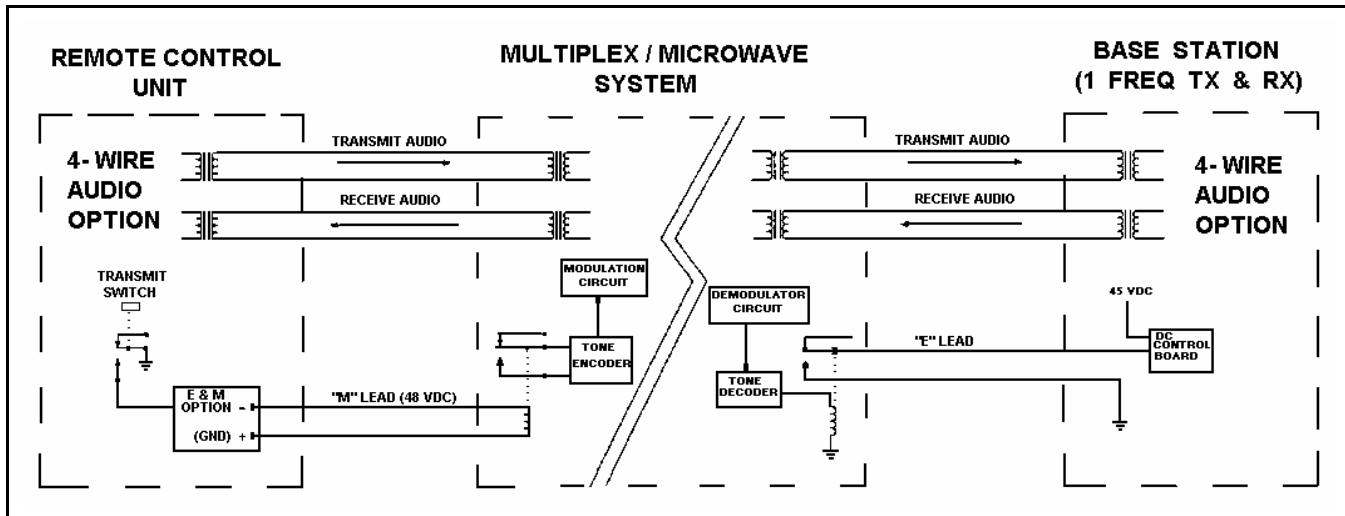

Figure 7-5: Typical E & M Signaling Application

### 7.2.2 Type 1 E & M Signaling

E & M Type 1 signaling uses two leads, E and M, which share a common ground path. Type 1 E & M signaling was originally designed for use with electromechanical switching systems and is not recommended for use in electronic systems due to the noise induced by the ground path.

Type 1 E & M signaling keys the station remotely by using a contact closure to ground. When this option is selected, control is exercised by applying a ground to P110 pin 1 (Repeater Hot Standby) on the station Interface Board or by applying a ground to P5 Pin 16 on the station backplane. This causes the station to execute a “Channel 1 – Remote PTT” which routes the audio from the **Line Input** to the transmitter.

## 7.3 TONE REMOTE INSTALLATION

In contrast with DC systems, where audio level setting is not as critical, it is important that levels in tone applications be set properly. Failure to do so results in the control function not working properly. For example, after the installation when the user has gained a little experience, the user may find that they are not always picking up the function selected. A little extra time spent at the installation will save many problems of this type later.

This equipment is designed so that the tone control sequence consists of two or three parts. The first part is the “**Secur-it**” tone (2175 Hz), which is sent at the highest level for approximately 125 milliseconds. This is followed by the “**Function**” tone which is sent at a level 10 dB lower for approximately 40 ms. In the case of a transmit function, the “**Function**” tone is followed by 2175 Hz “**Hold**” tone at a level 30 dB down from the “**Secur-it**” tone burst (therefore, it is 20 dB down from the “**Function**” tone burst). This tone continues for the duration of the transmit function. The average voice (0 VU) is sent at the same level as the “**Function**” tone, therefore, the test tone for the voice is sent at the same level as the “**Secur-it**” tone.

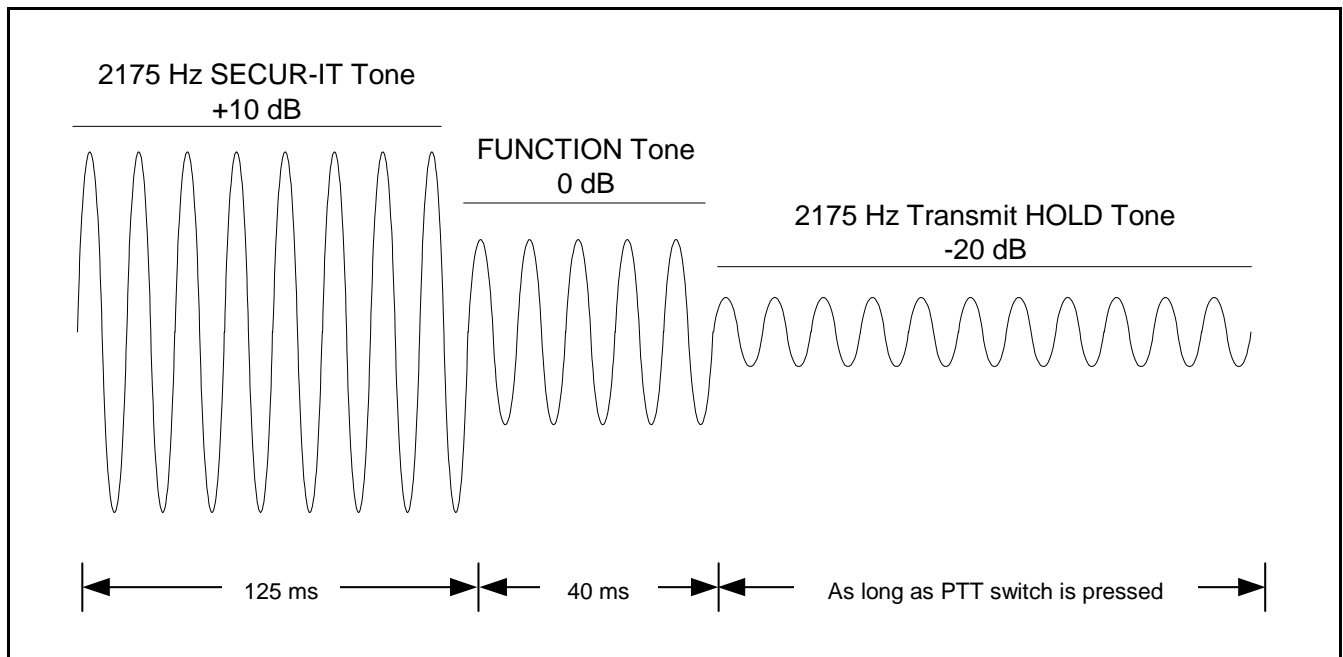

**Figure 7-6: Tone Control Sequence**

The “**Secur-it**” tone must arrive at the base station at no less than -20 dBm. The transmit “**Hold**” tone must arrive at the base station at no less than -50 dBm. The test tone for the voice must arrive at the base station at no less than -20 dBm. Therefore, the limits of system operation are usually established by only three things:

1. The maximum level at 2175 Hz that the phone company will allow to be sent from the most distant point in the system. Normally this will not be higher than 0 dBm. In some cases, it can even be less, or on rare occasions, it can be +5 or +10 dBm.
2. The loss of the circuit at 2175 Hz. Do not forget the long-term variation of up to 4 dB more.
3. The requirement that the “**Secur-it**” burst must arrive at the base station at no less than -20 dBm.

Normally, most systems will not crowd these limits. However, if the result is a few dB short, consider adding C-1 conditioning (at an added cost). Resist the natural desire to just turn up the tone sending level as this will cause improper system operation.

Increasing the level will cause the “**Secur-it**” tone burst to go into limiting in the phone company equipment. The limited tone causes the “**Secur-it**” tone filter in the base station to ring. This will result in picking up or dropping out functions, which were not selected. **NEVER** allow the “**Secur-it**” tone to be in limiting.

There is an easy way to check and see if the “**Secur-it**” tone is in limiting. With the phone lines connected to the equipment at both ends, connect an AC voltmeter across the phone line at the base station. Arrange to send a burst of “**Secur-it**” tone long enough to measure the incoming level on the AC voltmeter. Then arrange to send a burst of 1950 Hz “**Function**” tone long enough to measure the incoming level on the AC voltmeter. If the 1950 Hz tone does not arrive 10 dB (1 dB) less than the “**Secur-it**” tone, then the “**Secur-it**” tone is in limiting. It will become necessary to lower the sending level at the remote controller until it is below limiting.

If the audio is high enough to cause the telephone equipment to go into limiting, it will cause amplitude distortion. On a high loss line, the amplitude distortion will cause the “**Hold**” tone (2175 Hz) to vary and the transmitter to drop out.

On remote systems using tone control, care must be used when connecting two telephone lines in tandem. For example, for a base station and two remotes, a phone line is ordered to connect the station to the first remote, and a second line to connect the second remote to the first remote. The loss of each line is now added together and the tones from the second remote cannot operate the base station. The installer can either specify a low loss on each line, or run each line directly to the base station.

A check with the phone company can determine which approach is the least expensive over a period of time; i.e., an analysis of non-recurring costs versus recurring costs over the expected length of time the circuit will be used.

### **7.3.1 Voting System Considerations**

A voting system uses a continuous 1950 Hz tone on the telephone line when the receiver is squelched. This voting tone is normally sent from the station to the voting selector 3 dB lower than the 1000 Hz test tone level. Most telephone lines have a frequency response, which attenuates the 1950 Hz tone with respect to a 1000 Hz test tone; therefore, care should be taken to ensure that the correct levels are received at the voting selector.

If the telephone company will not allow a continuous tone as high as -8 dBm to be sent, then a lower loss circuit should be requested or C-1 conditioning added.

When ordering phone lines for a voting system, if possible, all lines should be of the same type. Different telephone line responses will cause the voter to prefer one signal to others.

It is improper system design to have the received signal selection biased by a “**poorer**” telephone circuit. Many telephone companies will add pads to build out the lines. If this is considered when the lines are ordered, it should not be difficult to build all of the lines out to have the same frequency response.

A tone remote control unit can initiate a transmission, listen to received audio, and select or deselect base station functions. Functions selected by the different available tones can be programmed so that a 1450 Hz “**Function**” tone, for example, can be used for different functions.

Signaling from a tone remote control unit consists of a high level “**Secur-it**” tone, followed by the appropriate medium level “**Function**” tone (as well as a “**Hold**” tone if the transmitter is keyed). The tone control sequence is shown in Figure 7-6.

The “**Secur-it**” tone is a +10 dB, 2175 Hz tone that is present for 125 milliseconds. The “**Secur-it**” tone is followed by a 40 millisecond, 0 dB “**Function**” tone. The “**Function**” tone can be followed by a -20 dB, 2175 Hz “**Hold**” tone if PTT is selected. The “**Hold**” tone is present as long as the PTT is pressed.

### **7.3.2 Function Tones**

The frequency of the “**Function**” tone determines the function selected by a tone remote control unit. “**Function**” tones range from 1050 Hz to 2050 Hz, and are spaced 100 Hz apart.

The following station functions can be controlled by tone signaling from a remote control unit:

- Repeater Enable (disable)



- Channel Guard Decode Enable (disable)
- Channel Guard Monitor
- Transmit Frequency Selection
- Receive Frequency Selection
- Scan
- Receiver Selection (Auxiliary Receiver selection)
- Auxiliary Output Enable (disable) (Auxiliary Control)

See Table 7-3 for a list of “**Function**” tones and their corresponding function.

**Table 7-3: Tone Control Function and Frequency**

FUNCTION	TONE
RX Channel Guard Disable (Reset by PTT)	2050 Hz
TX-Freq. No. 1	1950 Hz
TX-Freq. No. 2	1850 Hz
RX-Freq. No. 1	1750 Hz
RX-Freq. No. 2	1650 Hz
Channel Guard Decode On or Repeater Enable*	1550 Hz
Channel Guard Decode Off or Repeater Disable*	1450 Hz
TX-Freq. No. 3 or Aux. Function 1 On	1350 Hz
TX-Freq. No. 4 or Aux. Function 1 Off	1250 Hz
Repeater Enable*	1150 Hz
Repeater Disable* or Scan or Simultaneous Monitor	1050 Hz
* Repeater Enable (disable) is 1150/1050 only when Channel Guard On/Off is present.	

### 7.3.3 Wiring Methods for Tone Remote

**Table 7-4: Tone Remote Wire Line Installation Methods**

METHOD	DESCRIPTION	ADVANTAGES OR DISADVANTAGES
1	Standard two-wire configuration. Single voice grade pair used for both control and audio frequencies.	This is the most economical method and simplest to install. The cost varies depending on local service.
2	Standard four-wire configuration. One voice grade pair is used for TX audio and the other pair is used for RX audio.	This method is also economical. It minimizes keying clicks in paralleled remotes. Large ground currents may result in interference with control functions if remotes are located near sub-stations.

### 7.3.4 Installation Method 1 – Two Wire Tone Remote

When the control shelf is used with a two-wire tone remote/console, the remote control pair should be connected to TB101-3 and TB101-4. Jumpers on P104 and P105 located on the Interface Board are not required and should be removed.

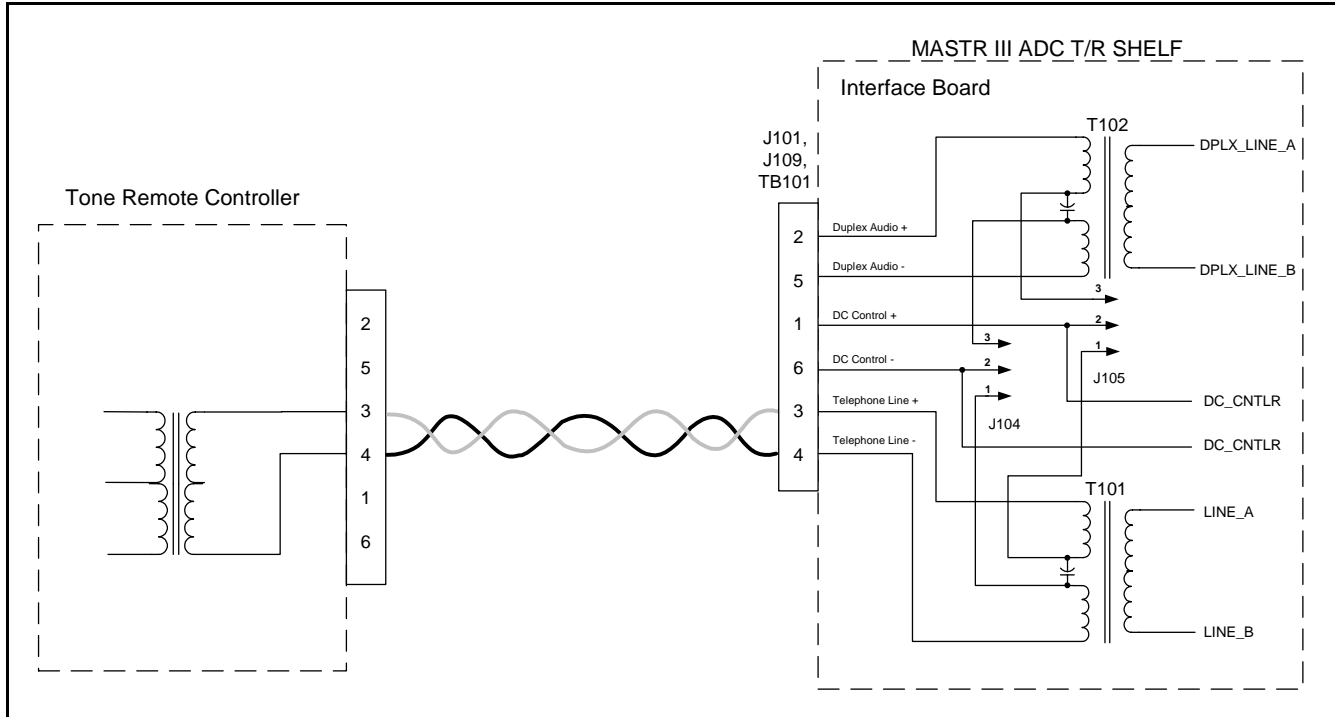

Figure 7-7: Tone Remote Installation Method 1

### 7.3.5 Installation Method 2 - Four Wire Tone Remote

When the control shelf is used with a four wire tone remote/console, the remote control transmit pair (which modulates the transmitter) should be connected to TB101-2 and -5. The remote control receive pair (which listens to the receiver) should be connected to TB101-3 and TB101-4.

## 7.4 T/R SHELF REMOTE CONTROL CONNECTIONS

### 7.4.1 Interface Board Connections

Telephone line connections may be made on the terminal block (TB101) or with an RJ-11 connector to J101 or J109. The telephone line cable may be routed through the top rear or bottom rear of the cabinet (refer to Figure 7-10 and the station Assembly Diagrams). The telephone line connections are shown in Figure 7-9.

If the system uses remote control, perform the following operations:

1. Make the connections to the Interface Board according to the remote control method described earlier in this section.
2. Ensure the Remote Control unit is properly installed and configured for the desired control method.

- Verify the jumpers on the Interface Board are set for the desired control method (refer to Table 7-5: Remote Control Jumper Installation).

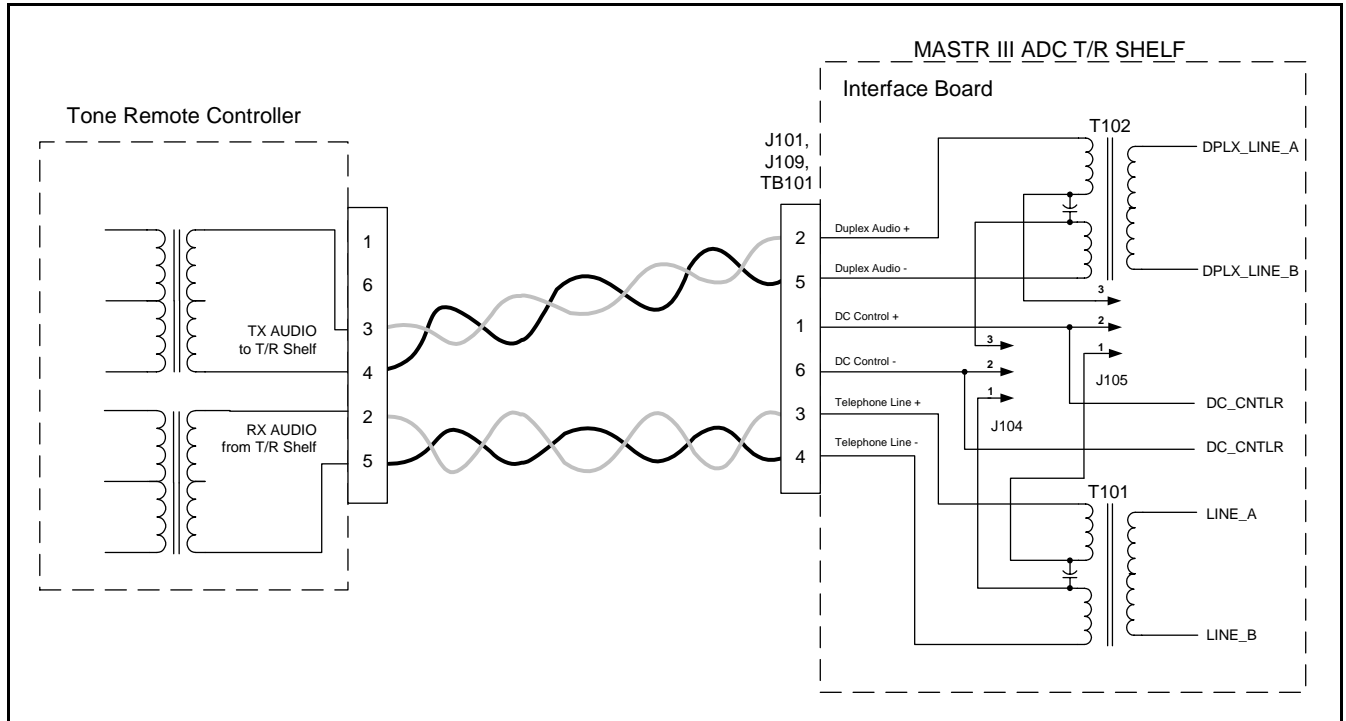

Figure 7-8: Tone Remote Installation Method 2

Table 7-5: Remote Control Jumper Installation

CONTROL METHOD	P104	P105
DC Control, 2-wire	1 & 2	1 & 2
DC Control, 4-wire	2 & 3	2 & 3
Tone Control	None	None
E & M	None	None



NOTE

The pin connections on TB101 are wired in parallel on the Interface Board with the corresponding pins on modular connectors J101 and J109. J101 and TB101 are accessible from the top of the T/R Shelf Interface Board. If the top of the Interface Board is inaccessible, then use J109, which is accessible from the rear of the cabinet. Connectors J101 and J109 are RJ-11 6-pin modular jacks.

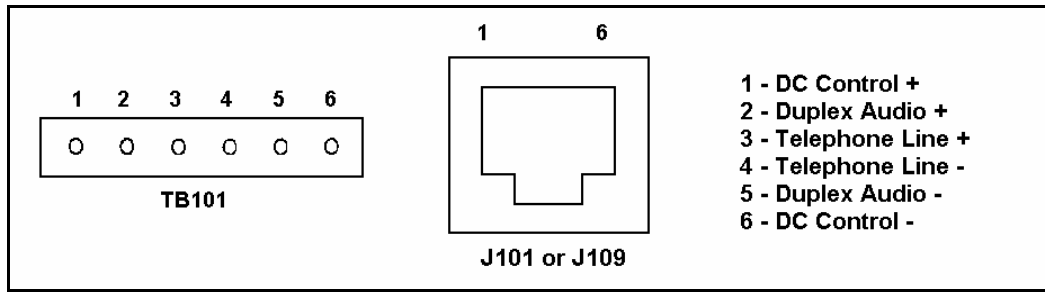

Figure 7-9: T/R Shelf Telephone Line Connections

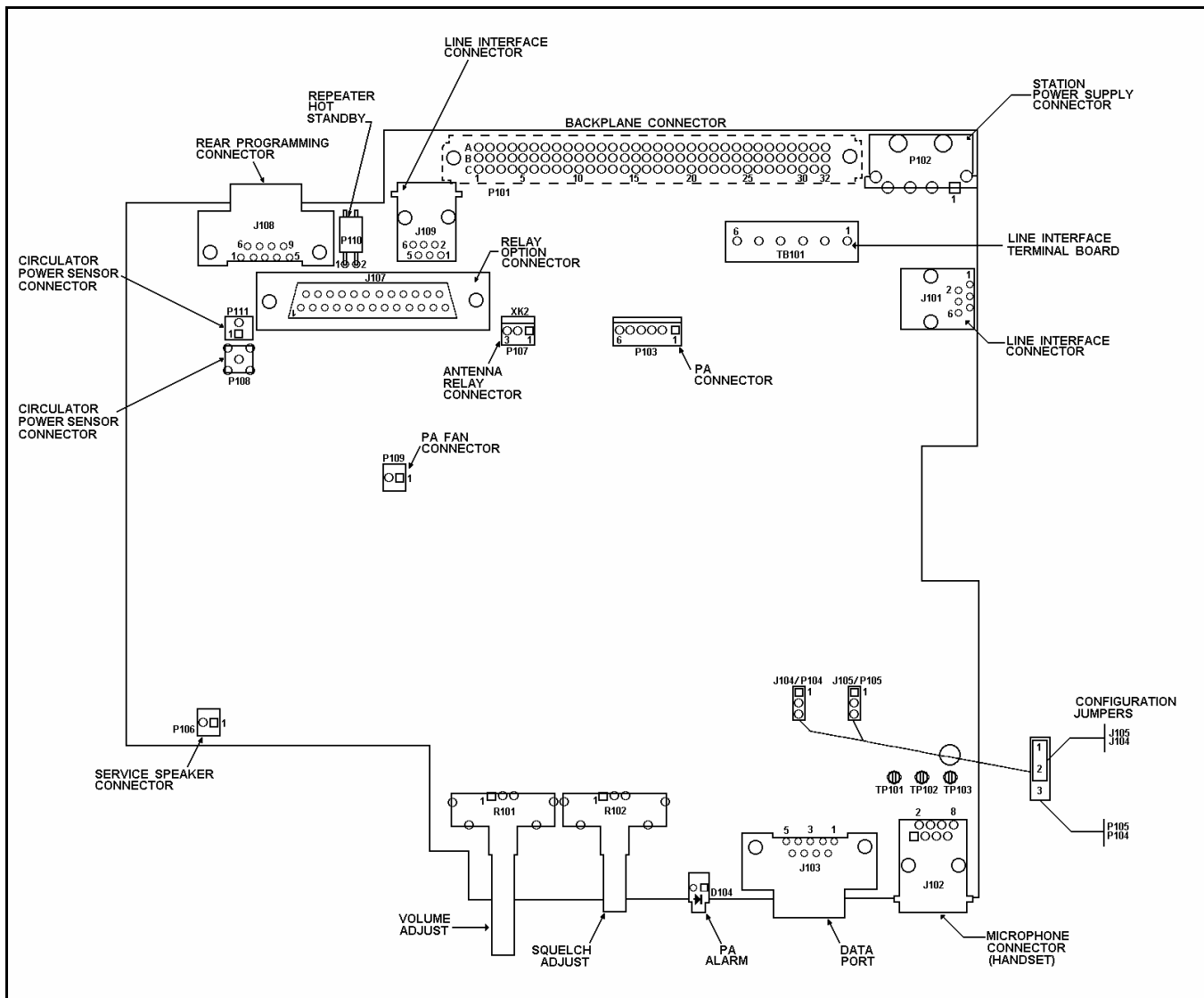

Figure 7-10: T/R Shelf Interface Board Connections

## 7.5 SQUELCH OPERATED RELAY OPTION (SXSU3D)

This section provides additional information for installing the Squelch Operated Relay (SOR) option SXSU3S. The option kit includes the following items:

- K3, SOR – 19B235003P2
- K1, AUX1 Relay - 19B235003P1
- K2, AUX1 Relay - 19B235003P1
- DB25 Extension Ribbon Cable – 19B802395P1

### 7.5.1 Installation

To install the kit, insert the relays and the ribbon cable on the Interface Board as shown in Figure 7-11.

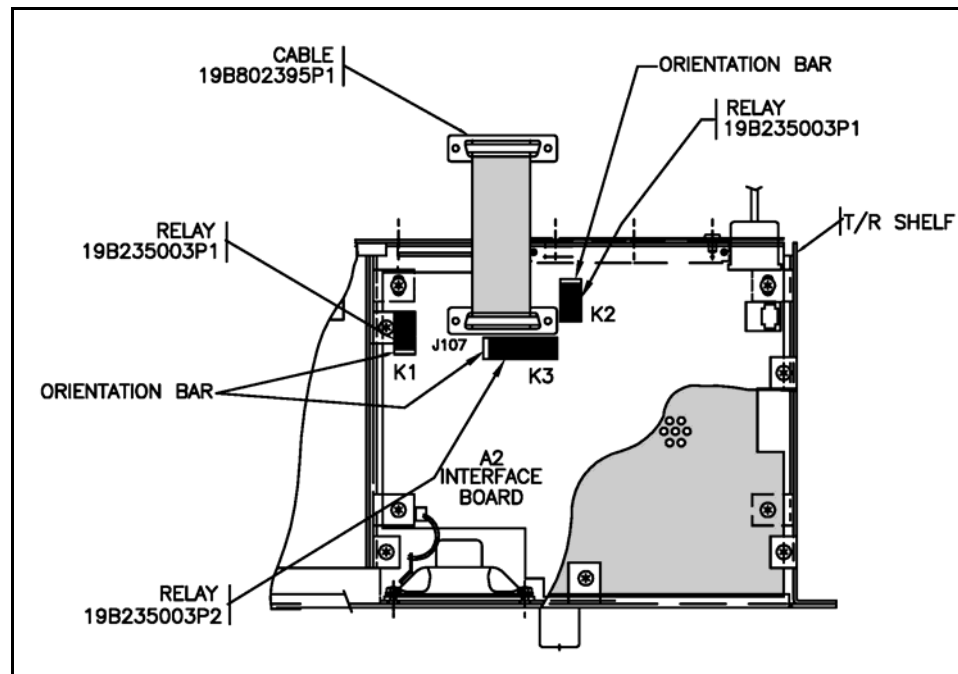

Figure 7-11: Squelch Operated Relay Option Installation

### 7.5.2 Operation

The SOR (K3) contains four form "C" contacts and is rated for 2 amps at 20 VDC. The relay operates under control of signal RX\_1\_MUTE, which is derived from CAS, with the coil of K3 being picked up by transistor switch Q110. (Refer to the SOR diagrams in Figure 7-12.)

AUX1 relay (K1) and AUX2 relay (K2) each contain two form "C" contacts and operate under remote control. When AUX1 function is started via remote control, the system microprocessor sets signal RXF3/AUX1 to logic high which turns on transistor switch Q112 picking up the coil of K1. When AUX2 function is started, the system microprocessor sets bit 4 of output register U106 high, turning on transistor switch Q111 picking up the coil of K2. When the AUX functions are stopped, the control bits are toggled, and the relay coil drops out.

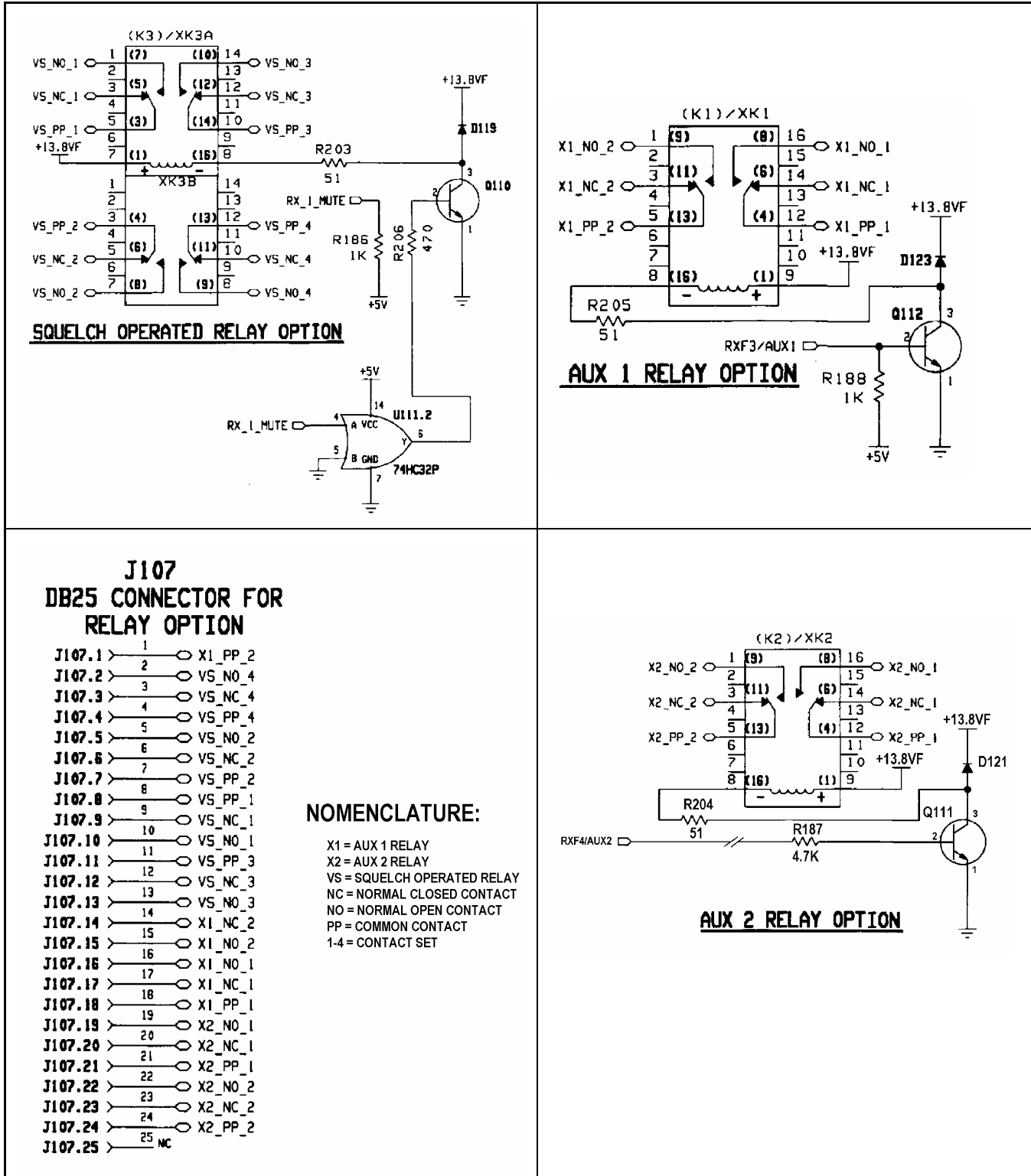

Figure 7-12: Squelch Operated Relay Option Connections

## 7.6 SHARED REPEATER PANEL INSTALLATION

This section provides information for installing and configuring the MASTR III Conventional ADC Base Station for use with a Shared Repeater Tone Panel.

### 7.6.1 General

The MASTR III ADC Base Station may be used as a “community” or “shared” repeater. This allows multiple users to share a common repeater. However, a common or shared repeater allows anyone transmitting on frequency and in some cases undesirable noise to pass through or unquench the system. This reduces the system availability and is annoying to radio users. To keep the nuisance listening to a minimum, a sub-audible tone signaling system, the Continuous Tone Coding Squelch System (CTCSS) and the Continuous Digital Coded Squelch System (CDCSS or DCS) were developed. In the MASTR III Base Station these squelch systems are referred to as Channel Guard (CG) and Digital Channel Guard (DCG). When used, an encoded sub-audible tone is sent over the air to the receiving station, which, in turn, has a decoder. The decoder doesn't let any sound through to the speaker until it hears the specific tone or code it was programmed to listen for. In the repeater system, decoding a given tone or code by the receiver results in encoding the tone or code along with the repeated audio on the repeater transmit frequency.

The MASTR III ADC Base Station can be programmed for multi-channel scanning with different CG tones (CTCSS) or DCG (CDCSS) codes. Programming the station requires using the MASTR III Programmer, (TQS3353) or MSEDIT (TQ0619) on site and scanning beyond two channels is impractical because of the time involved.

One solution to making a MASTR III Base Station into a “community” repeater is to use an external “shared” repeater panel or multi-tone CTCSS device. The repeater panel allows the system operator to program the repeater and to remotely add or remove users. Some repeater panels add other features, such as; audio processing, courtesy beeps, alarms, and timing and billing.

### 7.6.2 Repeater Panel Interface

The MASTR III ADC Base Station does not have a single connector for interfacing between the base station and the repeater panel. As a result, it is necessary to fabricate a special cable with three connectors or to solder wires directly to the backplane. The field engineer or installer should decide which method is most practical. The most reliable and least expensive method is to solder the interface wires to the connections on the backplane. However, a specially fabricated cable harness has definite advantages in time saved when installing or troubleshooting multiple repeaters.

The following tables (Table 7-6 through Table 7-8) can be used to identify the signal lines that interface with the repeater panel and where they can be found on the MASTR III ADC Base Station backplane (see Figure 7-13 for Backplane connector locations).

Table 7-6: Community Repeater Interface Signal Lines

SIGNAL NAME	DESCRIPTION
RCVR_VOL/SQ_HI	The receiver volume and squelch high line is the non de-emphasized output from the RX IF board. The level for standard deviation is 1-Vrms. Expect about 170 mVrms of CTCSS level when modulated at 15% system deviation.
SYS_VOL/SQ_HI	The System Volume Squelch High lead is normally the same point as the RCVR_VOL/SQ_HI. Jumper J11 must be removed from P11 on the backplane to separate the two leads. The SYS_VOL/SQ_HI is the return path of audio to the station. Removing the jumper and using this lead is undesirable. Processing of speech audio will be performed by the system module and any further external processing will complicate and sometimes cause problems. Reasons for using this circuit however may include squelch tail elimination, adding courtesy tones, or muting repeated audio. The overall gain of any audio processing should be unity and with a flat frequency response.
CAS	Carrier Activity Sensor (CAS) indicates the condition of the noise squelch circuit. A TTL level high (5 Volts) indicates an on channel carrier while a logic low indicates a lack of carrier.
EXT_LSD	External Low Speed Data lead goes to the system module. There the lead is switched to the high side of the CG electronic potentiometer. The level of the encode CTCSS or CDCSS should be set to between 0.5 and 1 Vrms. The final deviation level will be set by the CG electronic potentiometer during station alignment.
REPEAT_PTT_IN	Logic low or ground on this lead will key the transmitter and route audio from the SYS_VOL/SQ_HI and EXT_LSD leads to the transmitter audio circuits.
A+	Unfiltered power coming from the main station power supply. This point is not regulated to a specific value. Its voltage may vary with the load of the station, but usually it makes a good point for providing A nominal 12 VDC to the station. Do not use the +12 volt circuits to provide power to external devices.
DGND	Same as the chassis ground of the station. Can be use for DC return path.
AGND	Analog ground. Can be used to ground cable shields. If hum exists, add or remove the shield from the AGND to eliminate the problem.

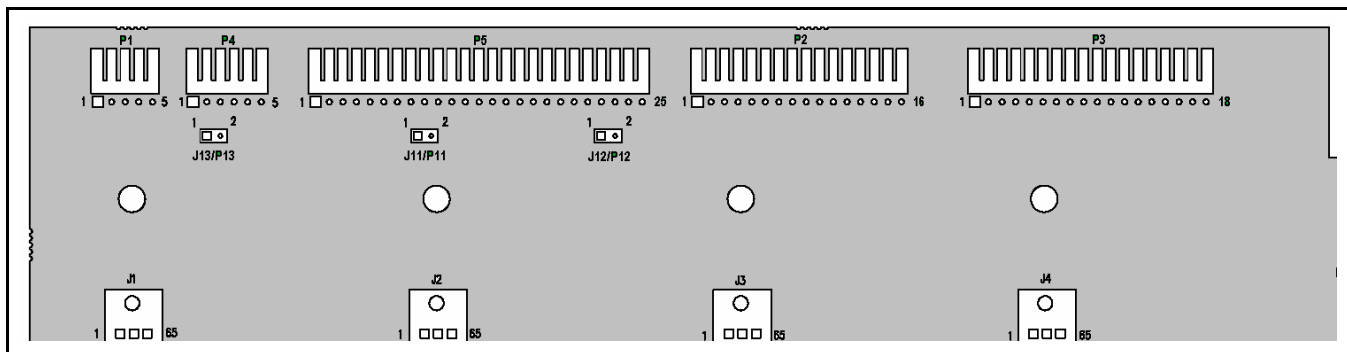

Figure 7-13: T/R Shelf Backplane Connections



Table 7-7: MASTR III Backplane Connections for Community Repeater Interface

SIGNAL NAME	MASTR III BACKPLANE CONNECTIONS			REPEATER PANEL
	P2 (GETC)	P3 (GETC)	P5 (VOICE GUARD)	
RCVR_VOL/SQ_HI	P2.5		P5.10	
SYS_VOL/SQ_HI			P5.8	
CAS		P3.5	P5.17	
EXT_LSD		P3.14		
REPEAT_PTT_IN	P2.13			
A+	P2.1		P5.1	
DGND	P2.2	P3.10	P5.12	
AGND			P5.4	

Table 7-8: Mating Connector Part Numbers

NOMENCLATURE	M/A-COM PARTS NUMBER	MOLEX PART NUMBER
J2 (connect to P2)	19A700041P42	22-01-2165
J3 (connect to P3)	19A700041P44	22-01-2185
J5 (connect to P5)	19A700041P50	22-01-2155
Pins (individual)	19A704779P26	08-55-0101

## 8. STATION TEST AND ALIGNMENT PROCEDURES

### 8.1 INTRODUCTION

This chapter provides instructions for testing and aligning the MASTR III Conventional or P25 Base Station. The base station is normally pre-aligned at the factory and ready to install. However, after initial installation and prior to placing the equipment into operation, it should be rechecked to ensure it is operating properly and meets the required specifications.

These procedures assume the receiver and transmitter modules have been previously tuned and aligned and should be used whenever a module or system component is repaired or replaced.

### 8.2 GENERAL

The MASTR III ADC Base Station comes pre-programmed and ready to install, the only adjustments needed are the required Line Output Level, the Line Input Level necessary to produce Standard Deviation, and the Line Cancellation for 2-wire Tone Remote Orientation. These adjustments can be made using the PC Programming option TQS3353, the Utility PC software TQ0619, or with the Utility Handset SPK9024.

The rated system deviations are as follows:

- 5.0 kHz Standard (25 kHz IF)
- 4.0 kHz NPSPAC
- 2.5 kHz Narrow (12.5 kHz narrowband)
- 2.8 kHz P25

### 8.3 SUPPORT EQUIPMENT REQUIRED

The following equipment and software may be require to perform the MASTR III ADC Base station alignment and tests:

#### 8.3.1 Hardware

**Table 8-1: Hardware Requirements**

DESCRIPTION	MODEL NUMBER	PURPOSE
Communication Test Set	IFR 1200, 1500 or equivalent	System test and alignment
Directional Coupler	Narda 3020A or equivalent	Test output power
RF Coaxial Load Resistor	Bird 8235	Test and alignment
RF Power Meter with 3% measurement accuracy	Boonton 4220A/51033er or equivalent	Test output power
Attenuator, 10 dB, 100 W	Bird 8343-100	Test and alignment

DESCRIPTION	MODEL NUMBER	PURPOSE
Extender boards	188D5338G1	Use to extend System and Power Modules
	188D5338G2	Use to extend RF Modules
RF Module Test Fixture	TQ0650	Individually test, align, and troubleshoot RF modules off station
PC Computer	See Table	Test, alignment and station personality programming
RS-232 Programming Cable	TQ3356 or equivalent DB9(M) to DB9(F)	Connect PC computer to T/R Shelf
Utility Handset	SPK9024	Test and alignment

Table 8-2: PC Computer Requirements

	Windows® NT 4.0 (Service Pack 4)	Windows 2000	Windows XP
<b>Processor Speed</b>	Pentium II 90 MHz	Pentium II 133 MHz	Pentium II 233 MHz
<b>RAM for Windows</b>	128 Megabytes	128 Megabytes	128 Megabytes
<b>Hard Drive Space</b>	160 Megabytes	160 Megabytes	160 Megabytes
<b>Drives</b>	CD-ROM	CD-ROM	CD-ROM
<b>Ports</b>	1 Serial	1 Serial	1 Serial
<b>Microsoft Internet Explorer</b>	Version 5.01 or higher	Version 5.01 or higher	Version 5.01 or higher

### 8.3.2 Software

Table 8-3: Software Requirements

DESCRIPTION	PART NUMBER	PURPOSE
MASTR III Programmer	TQS3353	Test, alignment and station personality programming
MASTR Utility Programmer (MASTRUTL)	TQ0619	Test and alignment (subset of MIII Programmer TQS3353)
Utility Handset	SPK9024	Test and alignment
DSP Module Programmer	TQS3413	DSP Module configuration and personality programming

## 8.4 STATION CONFIGURATION

Use the following procedures when setting up the station using a **Personal Computer (PC)**. If the Utility Handset is plugged into the MIC connector, it must be removed prior to resetting the system and using the PC Programming software. Levels may be adjusted using the MASTR III Utility program TQ0619 (**MASTRUTL**) supplied with the PC Programming package TQS3353.

1. Ensure proper connections are made to receive and transmit antenna(s).
2. Apply power to the equipment.
3. Connect the PC computer's serial COM port to the T/R Shelf DATA PORT using the TQ3356 Interconnect cable (19B801348P2) or equivalent. Refer to Figure 8-1.



The base station may also be programmed from the rear by connecting the computer to the rear Data Port connector (J108) located on the T/R Shelf Logic Board shown in Figure 7-10.

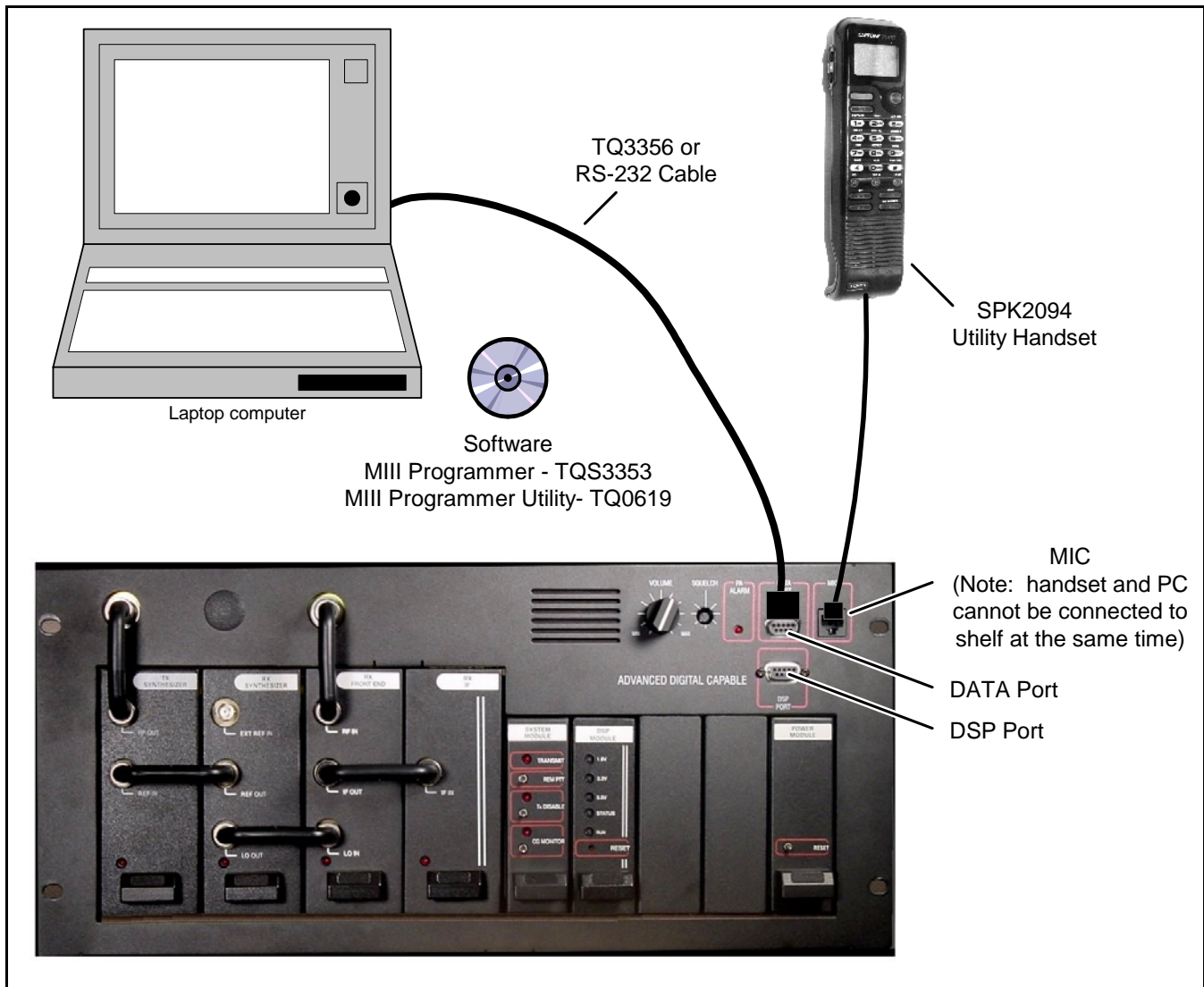
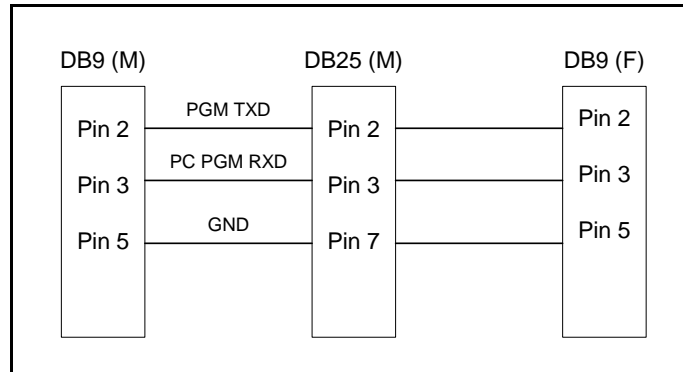

Figure 8-1: MASTR III Programmer Connections



If the computer has a 25-pin connector instead of a 9-pin serial connector, an adapter must be used. The adapter may be either purchased or locally manufactured. Making your own requires only three wire connections (Figure 8-2).



**Figure 8-2: DB9 to DB25 Adapter Cable**

4. Run the TQS3353 software and enter M3 to start the MASTR III program.
5. Initiate a **RESET** (on the Power Module) before programming starts.
6. The SQUELCH and VOLUME adjustments should be made for proper operation. Unsquench the receiver by turning the SQUELCH adjustment counter-clockwise. (*If your base station has Channel Guard, also activate the CG switch.*) Verify that unquench noise is going to the speaker by increasing the VOLUME (*clockwise*). Adjust the SQUELCH pot for critical squelch (squelch just closes).
7. Verify the current personality or create a new personality as required. Do not change Pot settings.
8. Following the initial setup, the MIC port may be used for one of the following purposes:
  - a. Connecting the local microphone equipped with a modular connector.
  - b. Connecting the multi-purpose Utility Handset.

## 8.5 STATION ALIGNMENT

Alignment of the MASTR III base station was performed prior to shipment. The factory assumed the following characteristics:

1. There is no loss or gain for repeated audio deviation.
2. If a remote exists, it is connected to the base station through a telephone line with 10 dB of loss.
3. The base station drives the line output at -10 dBm with nominal receive deviation.

The base station should deliver -10 dBm to the line with a signal applied with standard 3 kHz deviation. A -10 dBm audio signal applied to the Station Line In should result in transmitter deviation of 3 kHz.

These values may be altered by following one of the alignment procedures as provided. For minor adjustments, you may want to adjust only one or two digital potentiometers or leave the setting as set. In any case, it is important to carefully examine the Alignment Diagram (Figure 8-3).



It is a good idea to record the potentiometer settings on paper, until you're familiar with all the digital potentiometer setting process.

Figure 8-3 shows the relationship of the alignment pots in the station:

ADJUSTMENT	MSEEDIT/MASTRUTL POT NAME
CG	Channel Guard
CP	DSP Compressor Gain
CT	Compressor Threshold
DC	Line Cancellation
DLI	DSP Line In
LI	Line Input
LO	Line Out
PA	PA Power
RG	Repeater Gain
TX	Transmit



Refer to the Software Release Notes (SRN's) specific to release of software and hardware installed in this system for additional details on test setup and jumpers.



Only qualified field service technicians should perform these procedures. Each test has step-by-step procedures, along with visual aids when necessary, to check the performance or make alignment adjustments if needed to the individual system elements.

**Table 8-4: Digital Potentiometer Settings**

	LO POT	DC POT	LI POT	DLI POT	CP POT	CT POT	RG POT	TX POT	CG POT
	Line Out	DSP Line Cancellations	Line In	DSP Line In	DSP Compressor Gain	Compression Threshold	Repeater Gain	Transmit	Channel Guard
HANDSET NUMBER	1	5	3	6	7	2	2	2	1
POT PAGE (Note 1)	P_1	P_1	P_1	P_1	P_1	P_2	P_3	P_1	P_1
HANDSET DISPLAY	P LO	P DC	P LI	P DI	CP	CT	RG	P TX	P CG
DEFAULT VALUES	45	75 (2W) 0 (4W)	0	34 (2W) 28 (4W)	1023	1890	1023	127 150*	123 0*

\*No Channel Guard

**NOTES:** 1) Refer to Handset manual, LBI-38599, for instructions on page selection.

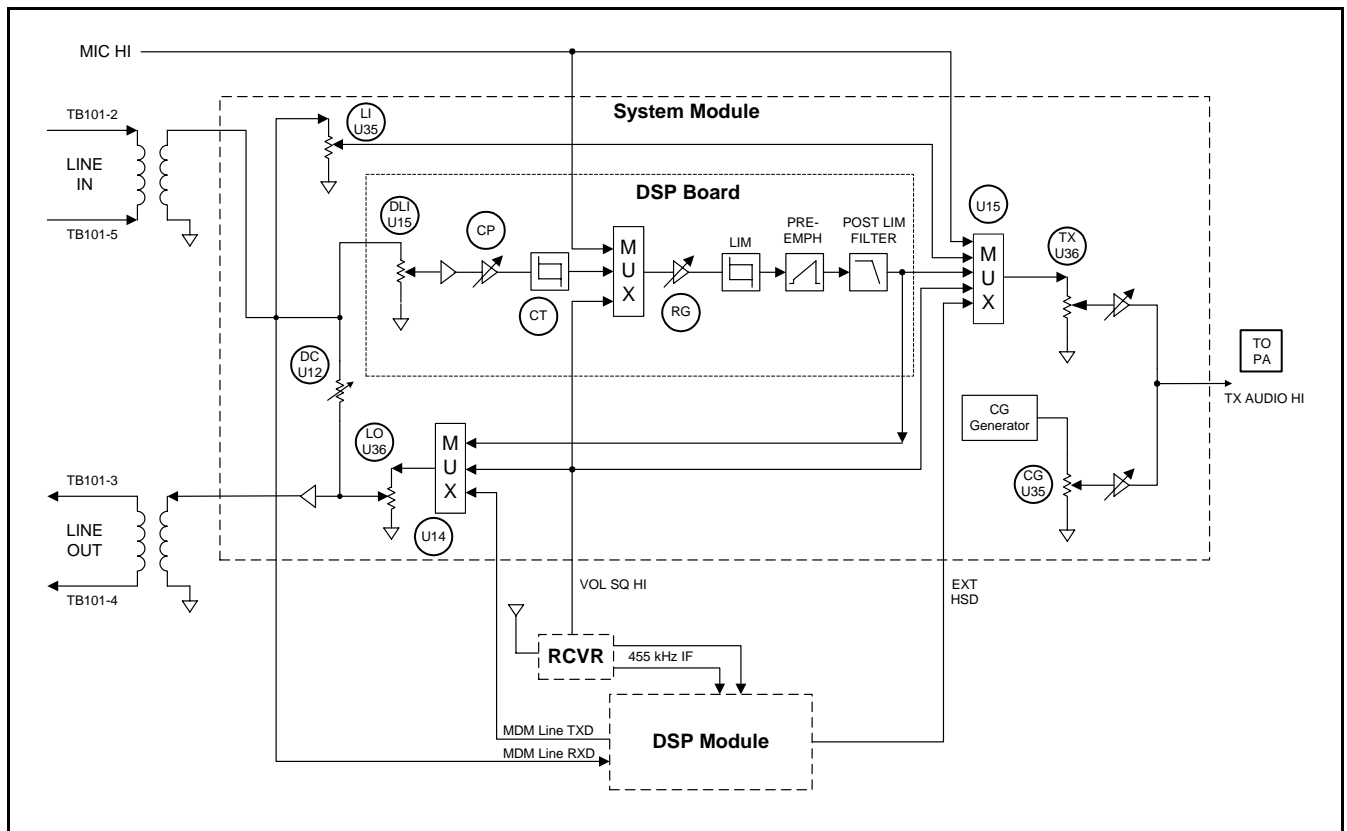

**Figure 8-3: MASTR III Conventional Base Station Alignment Controls**

### 8.5.1 Preparation

Unless otherwise stated, all adjustments and alignments in this section are to be made using the MASTR III PC Programming Utility Software (TQ0619). Tests may also be made using the Utility Handset (SPK9024). Refer to the Utility PC Programmer Manual (LBI-38540) or the Utility Handset Manual (LBI-38599) if necessary.

Perform the following steps before starting the alignment procedure:

1. Perform a controlled power up if station is not on. Check equipment for any abnormal indications
2. On stations that are assembled less MASTR III power supplies, supply adequate DC power to the station from an external power supply. Adjust the input voltage to the PA to  $13.4 \pm 0.3$  VDC ( $26.0 \pm 0.3$  VDC for the EA101292 Power Amplifier).
3. Connect the signal generator to the antenna system jack in all but repeater combinations or duplex stations. In repeater stations, a separate Receive antenna jack is provided.
4. For multi-frequency stations, activate the TX Disable switch on the System Module and select the desired receive frequency using the PC.
5. Adjust the SQUELCH and VOLUME for proper operation. Unsquelch the receiver by turning the SQUELCH adjustment counter-clockwise. Verify that unsquelched noise is going to the speaker. Adjust the volume if needed (clockwise to increase level).
6. Terminate Line Input (TB101-2, 5), and Line Output (TB101-3, 4), with 600 ohms.

7. Plug the Utility PC Programmer cable into the DATA connector, or Utility Handset cable into the MIC jack, both located on the front of the T/R Shelf. (Refer to Figure 8-1.)

**NOTE**

The Utility Handset and the Utility Programmer cannot be connected to the T/R Shelf at the same time.

### **8.5.2 Station Pot Defaults**

Adjust the following Station level control POT settings to the value indicated:

- Transmit Limiter (TX) 150
- Repeater Gain (RG) 1023
- Compressor Threshold (CT) 32767
- Compressor Gain (CP) 1023
- DSP Line Input (DI) 100
- Line Input (LI) 0
- DC 75

### **8.5.3 Channel Guard (CG) Pot**

The Channel Guard (CG) pot on conventional systems, sets the deviation level

If the station is **not** programmed for Channel Guard, set the CG pot to zero (0).

For stations programmed for channel guard encode, perform the following steps:

1. Connect the base station TX Synthesizer RF OUT (J2) to the Communications Test Set ANT IN.
2. Setup the Communication Test set to measure deviation.
3. Ensure the base station receiver is squelched for this test since RX audio will be routed to the transmitter.
4. Execute a REMOTE PTT by pushing the System Module **REM PTT** switch to the up position. This keys the transmitter.
5. Measure the transmitter deviation. Deviation must be within  $\pm 25$  Hz of the value listed in Table 8-5.
6. Adjust the Channel Guard deviation pot (CG) for the appropriate deviation as listed in Table 8-5.
7. Unkey the transmitter by releasing the REMOTE PTT.
8. Repeat this procedure for each frequency with channel guard.
9. **Disable** channel guard decode for the remainder of the station alignment.



**Table 8-5: Channel Guard Deviations**

SYSTEM TYPE	CHANNEL GUARD DEVIATION
Standard (25 kHz IF)	750 (750 Hz)
NPSPAC	600 (600 Hz)
Narrow (12.5 kHz narrowband)	500 (500 Hz)
P25	500 (500 Hz)

#### 8.5.4 Transmit Limiter (TX) Pot

The Transmit Limiter (TX) pot adjusts the limit of deviation for both Line In and Repeat Audio.

1. Preset the following pots as indicated:

- RG (Repeater Gain) - 1023
- CT (Compressor Threshold) - 5000
- CP (Compressor gain Pot) - 1023
- DLI (DSP Line Input) - 100

2. Apply a 1000 Hz tone at 0 dBm (775 mVrms) to the line input (TB101-2 and TB101-5).

3. Execute a REMOTE PTT by placing the System Module REM PTT switch to the up position. This keys the transmitter.

4. Measure the transmitter deviation. The deviation maximum value must be within  $\pm 100$  Hz of the value listed in Table 8-6

5. Adjust the Transmit Limit pot (TX) for the appropriate maximum deviation as listed in Table 8-6.

6. Unkey the transmitter by releasing the REMOTE PTT.

7. Remove the input signal from line input.

8. Repeat this procedure for each channel.

**Table 8-6: TX Limiter Max Deviation**

SYSTEM TYPE	TRANSMIT MAXIMUM DEVIATION
Standard (25 kHz IF)	4.5 kHz $\pm 100$ Hz
NPSPAC	3.6 kHz $\pm 100$ Hz
Narrow (12.5 kHz narrowband)	2.250 kHz $\pm 100$ Hz
P25	2.250 kHz $\pm 100$ Hz

**8.5.5 Repeater Gain (RG) Pot**

The Repeater Gain (RG) pot is set so that the deviation of the unsquelched receiver audio results in the transmitted audio having the same deviation.

If this is **not** a repeater station, leave the RG pot at 1023.

For a repeater station, perform the following steps to set the RG pot:

1. Set the Communication Test set for an “on-frequency” RF signal modulated by a 1 kHz tone at 60% of rated system deviation (see Table 8-7).
2. Connect the Test Set RF OUT to the Receiver Front End Module RF IN connector (J2).
3. Execute a REMOTE PTT by placing the System Module REM PTT switch to the up position. This keys the transmitter.

**Table 8-7: 60% of System Deviation**

SYSTEM TYPE	60% DEVIATION	
	CG Disabled	CG Enabled
Standard (25 kHz IF)	3.00 kHz	3.75 kHz
NPSPAC	2.40 kHz	3.00 kHz
Narrow (12.5 kHz narrowband)	1.50 kHz	2.00 kHz
P25	1.50 kHz	2.00 kHz

4. Measure the transmitter deviation. Verify the transmitted tone is 1 kHz and adjust the Repeater Gain (RG) pot for the required deviation listed in Table 8-7  $\pm 100$  Hz.
5. Unkey the transmitter by releasing the REMOTE PTT.
6. Remove the input signal from the receiver.
7. Repeat this procedure for each channel.

**8.5.6 DSP Line Input (DLI) Pot**

The DSP Line Input (DLI) pot adjusts the signal level going to the System Module DSP board.

If this is **not** a remote station, set the DLI pot to zero (0).

For a remote station, perform the following steps to set the DLI pot:

1. Apply a 1000 Hz tone at -10 dBm (245 mVrms) to the line input (TB101-2 and TB101-5).
2. Execute a REMOTE PTT by setting the System Module REM PTT switch to the up position. This keys the transmitter.

(This level is the function tone level, and is usually -10 dBm across 600 ohms, or 245 mVrms. This level **MUST** be 10 dBm below the "maximum system audio level" even if your actual secur-it tone and function tone are at the same level.)

3. Adjust the DSP Line In DLI Pot for 60% of maximum system deviation if operating with compression. (Table 8-8).

**Table 8-8: Deviation For Setting Line In Pot With Compression**

SYSTEM TYPE	DEVIATION FOR SETTING LINE IN POT WITH COMPRESSION	
	CG Disabled	CG Enabled
Standard (25 kHz IF)	2.80 kHz	3.55 kHz
NPSPAC	2.25 kHz	2.85 kHz
Narrow (12.5 kHz narrowband)	1.40 kHz	1.90 kHz
P25	1.40 kHz	1.90 kHz

4. Unkey the transmitter by releasing the REMOTE PTT.
5. Remove the input signal from the line input.
6. Repeat this procedure for each channel.

### **8.5.7 Compressor Gain (CP) Pot**

The DSP Compressor (CP) Pot is used to indicate the setting, which determines the level of line input voltage that will lead to compression. For remote systems using the DSP Compressor (all tone remote systems use the DSP Compressor), this field should be set so that nominal line input audio results in output audio, which is at rated (see Table 8-9).

If **not** a remote station set the CP pot to zero (0).

For a remote station, perform the following steps to set the CP pot:

1. Apply a 1000 Hz tone at -10 dBm (245 mVrms) to the line input (TB101-2 and TB101-5).
2. Execute a REMOTE PTT by switching the System Module REM PTT switch to the up position. This keys the transmitter.
3. Measure the transmitter deviation. Adjust the Compressor Gain (CP) pot for the required deviation listed in Table 8-9  $\pm 100$  Hz.
4. Unkey the transmitter by removing the REMOTE PTT.
5. Remove the input signal from the line input.
6. Repeat this procedure for each channel.

**Table 8-9: Deviation for Setting Compressor Gain Pot**

SYSTEM TYPE	DEVIATION FOR SETTING COMPRESSOR GAIN POT	
	CG Disabled	CG Enabled
Standard (25 kHz IF)	3.00 kHz	3.75 kHz
NPSPAC	2.40 kHz	3.00 kHz
Narrow (12.5 kHz narrowband)	1.50kHz	2.00 kHz
P25	1.50 kHz	2.00 kHz

### 8.5.8 Compressor Threshold (CT) Pot

The Compressor Threshold (CT) pot adjusts the maximum signal level appearing at the output of the compressor

If this is **not** a remote station, set the CT pot to zero (0).

For a remotely controlled station, perform the following steps to set the CT pot:

1. Apply a 1000 Hz tone at 0 dBm (775 mVrms) to the line input (TB101-2 and TB101-5).
2. Execute a REMOTE PTT by switching the System Module REM PTT switch to the up position. This keys the transmitter.
3. Measure the transmitter deviation. Adjust the Compressor Threshold (CT) pot for the required deviation listed in Table 8-10  $\pm 100$  Hz.
4. Unkey the transmitter by removing the REMOTE PTT.
5. Remove the input signal from the line input.
6. Repeat this procedure for each channel.

**Table 8-10: Compressor Threshold Deviation**

SYSTEM TYPE	COMPRESSOR THRESHOLD DEVIATION
Standard (25 kHz IF)	4.00 kHz
NPSPAC	3.20kHz
Narrow (12.5 kHz narrowband)	2.00 kHz
P25	2.00 kHz

### 8.5.9 DSP Line Cancellation (DC) Pot

The DSP Line Cancellation (DC) pot is used to specify 2-wire system settings for tone remote configurations. This separates the T/R Shelf's line output audio from the line input audio.

For stations using 2-wire tone remote control, set the DC pot to 75.

In all other configurations, set the DC pot to zero (0).

### 8.5.10 Line Output (LO) Pot

The Line Out (LO) pot adjusts the line out level for an output signal level of 0 dBm.

If this is **not** a remotely controlled station, set the LO pot to zero (0).

To perform receiver tests on a remote station, the LO level may be set to 0 dBm into a 600 ohm load. After these tests are completed, return the LO pot to zero.

For a remotely controlled station, perform the following steps to set the LO pot:

1. Set the Communication Test set for an “on-frequency” RF signal modulated by a 1 kHz tone at 60% of rated system deviation (see Table 8-11).
2. Connect the Test Set RF OUT to the Receiver Front End Module RF IN connector (J2).

**Table 8-11: Line Out Deviation Setting**

SYSTEM TYPE	60% DEVIATION
Standard (25 kHz IF)	3.00 kHz
NPSPAC	2.40 kHz
Narrow (12.5 kHz narrowband)	1.50 kHz
P25	1.50 kHz

3. Measure the line output level at J101-3 and J101-4 across a 600-ohm load. Adjust the LO pot for a 0 dBm (775 mVrms) indication.
4. Remove the input signal from the receiver.
5. Repeat this procedure for each channel.
6. If this is a channel guard station, re-enable Channel Guard Decode.

Note: 1) the line input is terminated to prevent line audio deviation while adjusting channel guard deviation.

### 8.5.11 P25 C4FM Deviation (DSP Module Adjustments)

This section provides instructions for aligning the DSP Module.



#### NOTE

Before aligning the DSP Module, the base station must be setup and aligned for conventional analog operation as described in sections 8.5.1 through 8.5.10.

### 8.5.12 Enable the P25 Operation in the System Module

Perform the following steps to enable the P25 Operation in the System Module.

1. Connect the programming PC to the Data Port on the front of the T/R Shelf.
2. Run the Master-III programming software. Configure the base station for the desired analog operation.
3. Set the P25 parameter on the OPTIONS screen to YES.

4. Write the new personality to the base station.
5. Cycle base station power to ensure proper operation.

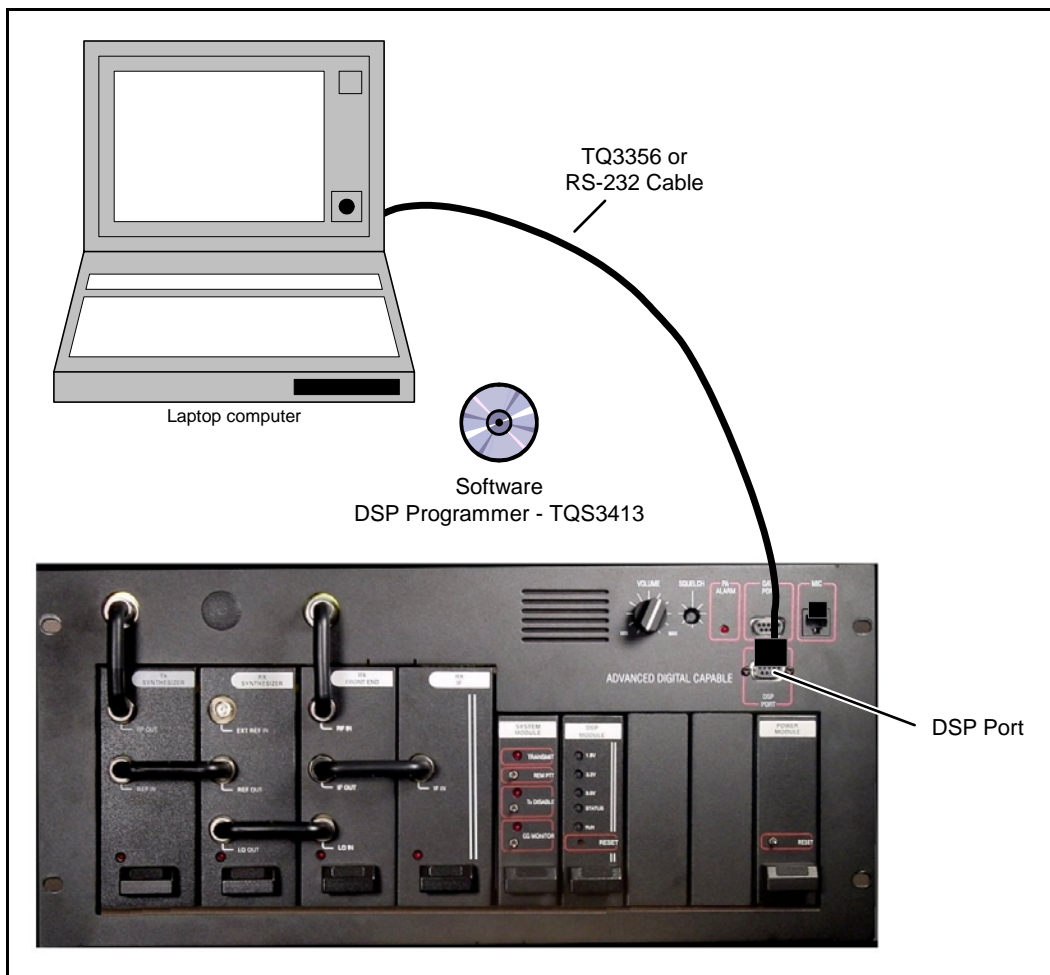

Figure 8-4: MASTR III DSP Module Programmer Connections

### 8.5.13 Adjust P25 C4FM Deviation

1. Run the DSP Module Programmer software (TQS3413).
2. Connect the programming PC to the T/R Shelf DSP Port using the TQ3356 RS-232 cable.
3. Ensure the PC Serial Port is properly configured.
4. From the DSP Module Programmer menu or toolbar, choose **Device**⇒**Personality**⇒**Read** to get the current personality saved in the DSP Module or **File**⇒**Open** to get a personality from the PC hard drive.
5. Modify the DSP Module personality as described below. (Refer to Table and review the personality parameters if needed).
  - On the P25 Base station Settings menu, set the *Transmit Test Mode* for **High Deviation Dotting Pattern**.

- Select **Device**⇒**Personality**⇒**Write** from the Programmer menu or toolbar to upload the revised personality.  
NOTE: Recycling power to the base station is not required.
6. Observe that the base station is transmitting.
  7. Measure the transmitter deviation of the P25 High Pattern. The deviation should be  $2826 \pm 25$  Hz. If the deviation is within limits proceed to step 11.
  8. If the deviation out of limits, adjust the High Deviation personality parameter. Entering a higher value increases the deviation.
  9. Select **Device**⇒**Personality**⇒**Write** from the Programmer menu or toolbar and upload the revised personality.  
NOTE: Recycling power to the base station is not required.
  10. Repeat steps 6 thru 9 until the deviation is  $2826 \pm 25$  Hz.
  11. Disable the Transmit Test Mode (Normal Operation) as described below.
    - On the P25 Base station Setting menu, set the *Transmit Test Mode* for **Disabled**.
    - Select **Device**⇒**Personality**⇒**Write** from the Programmer menu or toolbar to upload the personality.  
NOTE: Recycling power to the base station is not required.

**Table 8-12: P25 Personality Parameters**

PERSONALITY PARAMETER	DESCRIPTION	RANGE	DEFAULT VALUE
Source ID	Transmit Source ID for Landline Analog Interface.	1-	1
Talk Group ID	Transmit Talk Group ID for Landline Analog Interface.	1-65535	65535
TX Network Access Code (NAC)	Transmit Network Access Code for P25 Repeater and Landline Analog Interface. Review TIA 102.BAAD for detail NAC operation.	1-4095	659 (293 hex)
RX Network Access Code	Receive Network Access Code for P25 Repeater operation.	1-4095	3967 (F7F hex)
Preempt Enable	Enables a landline analog preempt over a RF Rx P25.	On/Off	On
Repeater Enable	Enables P25 RF Rx to P25 RF TX operation. When disabled, P25 RF Rx is only routed to the landline analog interface.	On/Off	On
Transmit Test Mode	Enables or disables various transmit test modes.	N/A	Disabled
High Deviation	P25 High Pattern deviation setting.	0-32767	15000

#### 8.5.14 SINAD Test

There are different SINAD values depending on the frequency band of the equipment (see step 3).

1. Connect the Communication Test Set output to the RF IN (J2) on the Receiver Front End module.

2. Connect the Communication Test Set Audio Input to the Line Output. **The line output in differential; some test sets may require conversion to a single ended signal.** If the conversion hardware is not available, measure just one side of the line out, but do not use the other line out as ground; connect test set ground to the MIII ground. Open the squelch.
3. Set the Communication Test Set to measure SINAD and adjust the RF level until an average 12 dB SINAD is attained. For 800MHz systems, the level must be less than -119dBm (i.e. more negative for example -120 dBm). For UHF and VHF systems, the level must be less than -116dBm (i.e. more negative for example -117 dBm).
4. If the SINAD is worse than (i.e. greater than) the required level, service the receiver. Record the 12 dB SINAD value on the Repeater data sheet in section 12.6.

**8.5.15 Squelch Adjustment**

1. Connect the Communication Test Set as for the previous test.
2. Adjust the Communication Test Set RF level for an average 3 dB below the previous SINAD reading.
3. Adjust the **Squelch** until it just closes.
4. Record the Squelch setting on the data sheet. Remove the Communication Test Set from the station.

**8.5.16 Transmitter Forward and Reverse Power**

This test measures the Forward and Reverse power of each channel. After the station forward and reverse power are verified, the station forward power will be adjusted to provide the required Effective Radiated Power at the transmit antenna.

**EFFECTIVE RADIATED POWER**

Effective Radiated Power (ERP) is the result of the calculation of Station Forward Power, Combiner loss, Feeder loss and Antenna gain.

**CABLE LOSS (dB/100 meter)**

FREQUENCY	SUPERFLEX			HELIAX	
	1/2"	7/8"	1 5/8"	7/8"	1 5/8"
150 MHz	2.77	1.50	0.919		
450	4.96	2.74	1.69		
824	6.90	3.85	2.40		
960	7.51	4.20	2.62		

**8.5.16.1 TX Forward Power (TX)**

1. Connect the 20 dB Directional Coupler to the station PA output at the back of the Repeater cabinet
2. Attach a 20 dB directional coupler and 150-watt RF load to the Transmitter RF Output.
3. Connect the RF Power meter to the attenuator port on the coupler.
4. Connect the MASTR-III Utility Programmer to the station and select PA Power.
5. Key the station, measure the Transmitter Output Power and adjust **PA Power**, if necessary, for the forward power level required to achieve maximum power for the station. Record the output power.
6. Add directional coupler loss plus cable and connector loss to the RF Power meter measurement.



**POWER MEASUREMENT ACCURACY**

If the measured value is within  $\pm 5\%$  of maximum power, do not adjust.

7. Toggle the **TX DISABLE** switch and disable transmission (TX Disable LED on).

**8.5.16.2 TX Reverse Power**

1. Connect the RF Power meter to the reverse power port on the 20 dB coupler. Terminate the forward directional coupler port.
2. Key the station, read the reflected power and record this value on the RF System data sheet. If this value is greater than 4 watts, service is required to reduce the reflected power.
3. Toggle **TX DISABLE** to disable transmission.
4. Remove directional coupler and reconnect cable to antenna.

## 9. SYSTEM FUNCTIONAL TESTS

### 9.1 GENERAL

The chapter describes the methods for functionally testing the MASTR III Conventional Base Station. Upon completion of these tests, the base station is considered operational.

### 9.2 SETUP

The following system functional tests may require up to four (4) portable or mobile radios of the type to be used on this system (conventional analog or P25 digital) - ideally they should be specimens from the customer's order. Many of the tests will only require two of these to be used.

Program all test radios with a minimum generic personality. The personalities should closely reflect the personalities of the customer's radios where possible.

### 9.3 CONVENTIONAL RADIO TEST

This test verifies the operation of a conventional analog base station.

1. Set the radios to the desired system or channel.
2. Ensure the channel is not busy and make a series of radio calls.
3. Confirm that the transmission can be heard in the receiving radio.
4. Set the radios for coded transmission (if programmed) and make a series of coded calls.
5. Ensure the receiving radio decodes the call.

### 9.4 P25 RADIO TEST

This test verifies the operation of a P25 base station.

#### 9.4.1 P25 Individual Calls

1. Ensure the radios and base station are configured for P25 operation.
2. Select the desired P25 system.
3. Select the radio unit to call (callee source ID) from the pre-programmed individual call list or enter the ID number on the radio keypad.
4. Make the call.
5. Confirm that the called radio unmutes according to the squelch mode defined in the radio personality (monitor, normal, selective).

#### 9.4.2 P25 Group Calls

1. Ensure the radios and base station are configured for P25 operation.
2. On the transmitting radio, select P25 system and the desired Talk Group/Conventional Channel.

3. On the receiving radios, select the desired P25 system and Talk Group/Channel or turn scan on and make sure the desired channel is in the scan list.
4. Make the call.
5. Confirm that the called radios unmute and receive the P25 call. The radio will unmute according to the squelch mode defined in the radios' personality (monitor, normal, selective).

## **9.5 REMOTE STATION OPERATION**

This test verifies the remote control of the base station.

1. In multi-frequency stations, check remote frequency control.
2. In channel guard stations, the MONITOR switch on the console should disable channel guard decode. Momentarily keying the transmitter will re-enable CG decode.
3. For Tone systems with CG ENABLE/DISABLE:
  - When the console is switched to CG DISABLE, CG Decode should be disabled. Keying the transmitter will not enable CG Decode.
  - Switching to CG ENABLE will enable CG Decode unless the MONITOR switch has been depressed. The microphone monitor switch will disable CG Decode even if the CG DISABLE/ENABLE switch is in the enable position.
4. Place a series of individual and group calls to radios. Ensure radios receive calls.
5. Make a series of calls using conventional and P25 (if applicable) radios and verify Remote Controller can monitor and respond to calls.

## 10. MODULE TESTING AND ALIGNMENT

### 10.1 GENERAL

The chapter describes the methods available for testing and aligning individual modules. If modules are suspected of being faulty, they should be tested and realigned by using one of the methods described in Table 10-1.

**Table 10-1: Module Test and alignment methods**

TEST OR ALIGNMENT METHOD	AFFECTED MODULES
<b>Bench Testing</b> (Removing the modules from the Station and using the TQ0650 RF Test Fixture)	<b>All RF modules</b>
<b>In-Station Testing</b> (Using the extender cards)	<b>All modules</b>



Before removing or replacing any module, power to the station must be switched off.

The preferred method for testing and aligning individual modules is to perform the Bench Test and Alignment. This involves removing the module from the base station and using the TQ0650 RF Module Test Fixture to test and align the module as described in section 10.2. After the module realignment is complete and it is reinstalled into the base station, it will be necessary to perform a full station alignment according to the procedures in chapter 8.

Individual modules may also be tested in the base station by using an extender card. Refer to section 10.2 for instructions on using an extender card to test individual modules.

There are two types of extender cards available for use with the MASTR III Base Station T/R Shelf. One extender card extends the modules installed in the RF section and the other for modules in the control section. Table 10-2 indicates which modules can be extended by each extender card.

Table 10-2: Extender Cards

EXTENDER CARD TYPE	AFFECTED MODULES
188D5338G2 RF Section Extender Card	<ul style="list-style-type: none"> <li>• Transmit Synthesizer</li> <li>• Receive Synthesizer</li> <li>• RX Front End RF Module</li> <li>• IF Module</li> </ul>
188D5338G1 Control Section Extender Card	<ul style="list-style-type: none"> <li>• Power Module</li> <li>• System Module</li> <li>• DSP Module</li> <li>• AMPF Module</li> <li>• Data Module</li> </ul>

## 10.2 BENCH TESTING

Bench Testing must be performed in a relatively clean shop environment using the TQ0650 RF Module Test Fixture. Usually when a module is suspected of being defective or out of alignment, the affected channel is to be taken out of service and the failed module is to be removed and replaced with a known good module. If a replacement module is installed, the station should be completely realigned and the channel returned to service. The module removed is then taken to a Maintenance Facility for bench testing and alignment.

The TQ0650 RF Module Test Fixtures 344A4235P1 (no longer available) and the TS101285V1 are capable of testing the modules listed in Table 10-3. Instructions for using the RF Module Test Fixture are contained in manuals LBI-38805 (344A4235P1) and MM101885V1 (TS101285V1), which are included in the TQ0650 package. These manuals provide instructions for setting up the test fixture and running the test software. A personal computer is also required.

The test technician should refer to the applicable technical manual for the module under test for detailed alignment requirements.



**NOTE**

There are no bench tests for the System Module. Should this module fail during in-station alignment, it is to be replaced and the failed module returned for repair.



Before removing or replacing a module, power to the station must be switched off.

Table 10-3: TQ0650 and MASTR III RF Module Compatibility Chart

MODULE	PART NUMBER	RF MODULE TEST FIXTURE	
		TS101285V11	344A4253P1
Transmit Synthesizer	19D902780	X	X
	EA101685	X	
Receive Synthesizer	19D902781	X	X
	EA101684	X	
RX Front End RF Module	19D902782	X	X
IF Module	19D902783	X	X
	EA101401	X	
	EA101794	X	
Power Amplifier	19D902797	X	X
	EA101292	X	

### 10.2.1 Procedure

To remove a module for bench testing, the following steps are to be taken:

1. Switch OFF power to the affected channel (T/R Shelf).
2. Remove the module.
3. If possible, replace the module with a known good module and realign the Base Station and return it to service.
4. Return the defective module to the test facility and connect it to the RF Module Test Fixture.
5. Bench Test the module according to the instructions in LBI-38805 or MM101885V1. Test and realign the module if possible. If it fails the testing, it should be sent for warranty repair or replacement.

When testing is complete, replace the module and re-check alignment as follows:

1. Power to the channel must be switched off.
2. Place the module into the correct slot in the station.
3. Reapply power to the channel.
4. Perform complete station alignment.
5. Return the channel into service.

## 10.3 IN-STATION TESTING

For In-Station Testing, refer to the appropriate technical manual for the module under test.



Before removing or replacing a module, power to the station must be switched off.

### 10.3.1 Procedure

To prepare the module for In-Station Testing, the following steps are to be taken:

1. Remove power to the affected channel (T/R Shelf).
2. Remove the module and place the RF Module Extender Card into the T/R Shelf.
3. Insert the module into the Extender Card.
4. Reapply power to the channel (T/R Shelf).
5. Tests may now be performed. Refer to the applicable module maintenance manual for testing information.

When testing is complete, replace the module and re-check alignment as follows:

1. Power to the channel must be switched off.
2. The Extender Card is to be removed and the module replaced into the correct slot in the station.
3. Power is to be reapplied to the channel.
4. Alignment must be verified and station realigned if necessary.
5. Return the channel into service.

## 10.4 CHANGING THE BASE STATION FREQUENCY



The following procedures may be used in the field to retune a station if an RF module has been repaired or replaced or the station frequency has been changed. The preferred method is to use the RF Test fixture and the module alignment found in section 10.2 and the specific RF module maintenance manual.

Changing the frequency in a MASTR III ADC Base Station requires frequency planning, examination of the antenna system specifications, realignment of the RF system, and realignment of the Base Station.

The preferred method for retuning modules is to remove the modules from the Station as described in section 10.2 and to use the RF Test Fixture to realign the RF modules.

The only modules that require realignment are the TX and RX Synthesizer and RX Front End modules, but the remaining modules should be checked to ensure that they still operate correctly. When the module realignment is complete, reinstall the modules and perform a complete station alignment using the procedures in the Station Alignment section 8.4.

If it is necessary to retune the modules in the field and an RF Test Fixture is not available, then use the following procedures to realign the modules. The TX and RX Synthesizers can be retuned in the field by using the metering functions available with the Utility handset SPK9024, MASTRUTL (TQ0619), or MSEDIT (TQ0653). The VCO tune voltage from the RX Synthesizer slot in the T/R shelf is connected to the external metering jack (EXT\_JCK) in the System Module.

### **10.4.1 Vendor Equipment**

The specifications of the following equipment, if used, must be checked for Frequency Isolation and Frequency Separation issues and should be realigned where necessary:

- Combiner
- Multicoupler
- Filter
- Antenna element

### **10.4.2 800 MHz Stations**



**NOTE**

There is no requirement to tune 800 MHz Station Front End or IF Modules.



**WARNING**

Before removing or replacing a module, power to the station must be switched off.

1. Remove the cover of the RX Synthesizer and place on an extender card.
2. Program the station for the desired TX and RX frequencies.
3. Adjust the RX Synthesizer trimmer until the LED on the front of the module goes out.
4. Monitor the EXT metering field and adjust the trimmer for a V Test reading of 5 VDC on the EXT Metering field or on J3 pin 23A.
5. Remove RX and TX Synthesizers. Place the RX Synthesizer in slot farthest to the left and the TX Synthesizer on the extender in the slot next to the RX Synthesizer. Using a U-Link (344A3052P1), connect the TX Synthesizer Ref In (J1) to the RX Synthesizer Ref Out (J3).
6. Key the station with the REM PTT switch on the System Module.
7. Adjust the trimmer on the TX Synthesizer for a reading of 5 VDC on the EXT Metering field or on J3 pin 23A.
8. Replace all modules into the Station and confirm complete station alignment as described in Station Alignment section.



### 10.4.3 UHF Stations



**NOTE**

There is no requirement to align UHF Station TX Synthesizer or IF Modules.



**WARNING**

Before removing or replacing a module, power to the station must be switched off.

1. Remove the cover of the RX Synthesizer and place on an extender card.
2. Program the station for the desired TX and RX frequencies.
3. Adjust the RX Synthesizer trimmer until the LED on the front of the module goes out
4. Monitor J2 and align FL1 for a peak output level using a Spectrum Analyzer or RF Voltmeter. Programmable bandwidth is  $\pm 1$ MHz.
5. Place the Front End Module on an extender card and connect the LO out of the RX Synthesizer and the IF out of the Front End to the IF Module with 50 $\Omega$  Coax cable.
6. Preset the Front End tuning slugs according to the instructions in the RX Front End technical manual and apply an “on frequency” signal into the RF In on the Front End Module.
7. Monitor the RSSI metering function and adjust the level of the “on frequency” signal to the responsive range of the meter.
8. Tune the Front End tuning slugs for a peak on the RSSI meter while reducing the input signal level to keep the meter in the responsive reading range.
9. Replace all modules into the Station and confirm complete station alignment as described in Station Alignment section.

### 10.4.4 VHF Stations



**NOTE**

There is no requirement to tune the 19D902780G1 VHF TX Synthesizer Module.



**WARNING**

Before removing or replacing a module, power to the station must be switched off.

1. Ensure that the TX Synthesizer Dip switches are set for the required frequency range.
2. Align the RX Synthesizer trimmers until the LED on the front panel of the module goes out.

3. Monitor J2 and align FL1 for a peak output level using a Spectrum Analyzer or RF Voltmeter. Programmable bandwidth is  $\pm 1$  MHz.
4. Place the Front End Module on an extender card and connect the LO out of the RX Synthesizer and the IF out of the Front End to the IF Module with 50 $\Omega$  Coax cable.
5. Preset the Front End tuning slugs according to the instructions in the RX Front End technical manual and apply an "on frequency" signal into the RF In on the Front End Module.
6. Monitor the RSSI metering function and adjust the level of the "on frequency" signal to the responsive range of the meter.
7. Tune the Front End tuning slugs for a peak on the RSSI meter while reducing the input signal level to keep the meter in the responsive reading range.
8. Replace all modules into the Station and confirm complete station alignment as described in Station Alignment section.

## 10.5 STATION ADJUSTMENTS FOR REMOTE CONTROL OPERATION

Although audio levels should be considered on a system basis, it is appropriate to set the levels of the remote controller and the control station panel by themselves with reference to the levels required by the transmission path and then connect the controller(s) and station to the path. The transmission path, if it is more than just a simple twisted pair, is usually set up with a "test tone". The "average voice" level is defined as being a certain number of decibels below the test tone. The test tone is normally the maximum level that can be sent through the path without clipping or being regulated. Although there is no definite agreement on the difference between the test tone and average voice levels, 10 dB is an appropriate level.

In order to align the Remote Controller and T/R Shelf properly, it will be necessary to have some information on the transmission path. This will help to determine the levels at each end required by the system. Specifications needed include:

1. Loss at 1 kHz
2. Test tone or maximum level
3. Average voice level (if defined)
4. Loss at 2175 Hz (if tone remote)

The DSP Board performs tone detection in a tone remote installation. The "**Secur-it**" tone Decoder on this board has a dynamic range of approximately 9 dB. The system must be set up such that the "**Secur-it**" tones from all remotes in the system arrive at the T/R Shelf within this 9 dB window.

### 10.5.1 Line Out Level Adjustment

U36-1 is used to set the line out level. Analog switch U14 selects which audio source is routed to the line. Possible sources are LOCAL MIC, VOL/SQ, auxiliary receiver audio, auxiliary receiver audio summed with VOL/SQ (simultaneous monitor), DSP LINE/TX AUDIO, MODEM LINE data, OPEN (used for battery alarm), GROUND (used for no transmission, and LINE IN audio (used for four wire loop around). A battery alarm tone and/or VG ALERT tone may also be summed in with whichever source is selected with the exception of GROUND. Typically LOCAL MIC, VOL/SQ, DSP LINE/TX AUDIO, OPEN, or GROUND will be selected.

The gains in the circuitry are set such that 100 mVrms in on MIC HI or 1 Vrms (3 kHz deviation) in on VOL/SQ HI (REPEAT AUDIO) will produce the same line output level. The gains for VG ALERT tone

and battery alarm are also designed to provide the proper levels without adjustments. The LINE output level should be adjusted with a 100 mVrms, 1 kHz signal in on MIC HI or a 1 Vrms, 1 kHz signal in on VOL/SQ HI.

### 10.5.2 DSP Line In Level Adjustment

Typically, the TX AUDIO and LINE OUT levels should be adjusted prior to adjusting the DSP LINE IN level. DSP TX AUDIO and DSP LINE/TX AUDIO are typically line audio or VOL/SQ HI audio that has been processed by the DSP Board.

A DSP Board is always present; this DSP processed line in audio will normally be selected by analog switches U14 (DSP LINE/TX AUDIO to line out) and U15 (DSP TX AUDIO to transmit audio) on the System Module when line in audio is selected. The level for DSP TX AUDIO and DSP LINE/TX AUDIO must be adjusted on the DSP Board.

### 10.5.3 DSP Level Adjustments

The DSP LINE IN level into the DSP must be adjusted using U15-0 (DSP line cancellation level) and U15-1 (DSP line input level) located on the DSP Board. If two-wire audio is used then both electronic pots must be adjusted. If four-wire audio is used then only U15-1 needs to be adjusted.

For two wire installations the DSP line cancellation level pot (U15-0) is used to remove what the T/R Shelf is sending to the line. While the T/R Shelf is sending received audio down the line, the line cancellation pot should be adjusted to minimize the signal level at TP1 on the DSP Board. This leaves only what is received from the remote. This signal is then level adjusted using the DSP line input level adjust pot (U15-1) and input into the DSP.

**NOTE**

System Modules 19D902590G6 & G7 have TP1 extended to the board edge connector and may be metered on the MASTR III backplane at J5, Pin 28A.

If four-wire audio is used, the DSP line cancellation pot must be set to zero.

The DSP also performs a compressor function on its DSP line input. The threshold for this compressor must be adjusted as well. The line level should be adjusted on the DSP Board prior to setting the compressor threshold.

## 11. PREVENTATIVE MAINTENANCE

### 11.1 GENERAL

Preventative Maintenance is a periodic check of the station's operation. The results of the check may indicate that the station needs realignment if its performance has drifted from the installation values or the values documented in the previous inspection.

It allows for:

1. Operational test and re-adjustment of each Base Station's alignment,
2. Operational test and re-adjustment of RF System equipment,
3. Operational test and re-adjustment of the Power System.

Preventative Maintenance should be performed every 6 months, or sooner if required by the customer. The tests will follow those defined in this manual and will require the test engineer to refer to the Installation Checklists or last Preventative Maintenance Checklists to determine any variance in performance.

The results of these tests are to be recorded on the Preventative Maintenance Checklists in section 12.7

### 11.2 BASE STATIONS



To disconnect the power to the base station for maintenance, unplug the power supply from the AC outlet.

#### 11.2.1 Test Equipment

The Test Equipment requirement is as defined in the "Station Test and Alignment" Section. Ideally, the same test equipment should be used for every channel at the site. If more than one of a particular type of Test Equipment is used, ensure that they are calibrated to each other.



For checking station frequency, a high accuracy reference is required (better than 1 part in  $10^{-7}$ ). The internal oscillator on many counters is not sufficiently precise.

#### 11.2.2 Tests

Refer to the "Station Test and Alignment" Section for detail of the tests. Perform tests to ascertain current levels and note these on the Checklist. If adjustment is necessary, perform the realignment and note the new levels and Control Pot settings for each test.

## 11.3 RF SYSTEM

This test does not address RF System between the bulkhead and the antenna elements. The RF System comprises:

1. Combiner
2. Multicoupler
3. Receive Filter
4. RF Cabling to Bulkhead

### 11.3.1 Combiner

Follow the test procedures defined in the Combiner vendor manual to ensure correct performance for each and for all channels. If alignment is required, follow the procedures outlined in the vendor's manual. Document and file the results with the Base Station Checklists.

### 11.3.2 Multicoupler

Follow the test procedures defined in the Multicoupler vendor manual to ensure correct performance for each and for all channels. If alignment is required, follow the procedures outlined in the vendor's manual. Document and file the results with the Base Station Checklists.

### 11.3.3 Receive Filter

Follow the test procedures defined in the Receive Filter vendor manual to ensure correct performance for each and for all channels. If alignment is required, follow the procedures outlined in the vendor's manual. Document and file the results with the Base Station Checklists.

### 11.3.4 RF Cabling to Bulkhead

RF Cabling includes coaxial cables, power sensors and RF protection. If tests indicate that the RF Cabling is in error, follow the test procedures in this manual for power sensors and RF protection to ensure correct performance. If alignment is required, follow the procedures outlined this manual. Document and file the results with the Base Station Checklists.

## 11.4 POWER SYSTEM

Follow the Power System test procedures defined in the Power System section of this manual to ensure correct performance. If alignment is required, follow the procedures outlined in the vendor's manual. Document and file the results with the Base Station Checklists.

## **12. CHECKLISTS**

These checklists, when filled in, will provide a complete record of the MASTR III Conventional or P25 Base Station installation.

## 12.1 SITE DATA SHEET

Customer Name: \_\_\_\_\_

Local Customer Contact Name: \_\_\_\_\_

Local Customer Phone: \_\_\_\_\_

Site Name: \_\_\_\_\_

Site Address: \_\_\_\_\_

\_\_\_\_\_

\_\_\_\_\_

Site Telephone Number: \_\_\_\_\_

If Site is Leased, Owner's Name\Tel: \_\_\_\_\_

Access Controlled by (Name, Phone): \_\_\_\_\_

Site Latitude (Deg., Min., Sec.): \_\_\_\_\_

Site Longitude (Deg., Min., Sec.): \_\_\_\_\_

Site Elevation above sea level: \_\_\_\_\_

FCC License ID/Call Sign: \_\_\_\_\_

Site Equipment Type: Conventional Station  P25 Station  Encrypted Station

Number of Channels: \_\_\_\_\_

Check Control Options: DC Remote Operation  Repeater Option

DC Remote /Repeater  Tone/Remote Repeater

Multisite Audio Link Loss (dB) \_\_\_\_\_

Multisite Link type: Leased Line  Microwave  FiberOptic

Installation Date: \_\_\_\_\_

Installed By (Company Name): \_\_\_\_\_

Tower Type: Self Supporting

Guyed

Monopole

Other

Tower Height: \_\_\_\_\_

Tower FAA Options: Painted  Lights

Antenna System: Single  Multi

If Multi-Antennas, Number of Transmit: \_\_\_\_\_ Transmit Antenna Height: \_\_\_\_\_

If Multi-Antenna, Number of Receive: \_\_\_\_\_ Receive Antenna Height: \_\_\_\_\_

Transmit Helix Type: \_\_\_\_\_ Transmit Antenna Azimuth: \_\_\_\_\_

Receive Helix Type: \_\_\_\_\_ Receive Antenna Azimuth: \_\_\_\_\_

Transmit Antenna Model: \_\_\_\_\_ Transmitter Combiner Model: \_\_\_\_\_

Receive Antenna Model: \_\_\_\_\_ Tower Top Amplifier: YES  NO

If Tower Top Amplifier, Model: \_\_\_\_\_

Receiver Multicoupler Model: \_\_\_\_\_

## 12.2 INSTALLER PROFILE DATA SHEET

Installer's Company Name: \_\_\_\_\_

Installer's Telephone Number: \_\_\_\_\_

Installer's Name (s): \_\_\_\_\_

Technician's Name (s): \_\_\_\_\_

Date of Testing Complete: \_\_\_\_\_

Test Equipment Used,  
if other than specified: \_\_\_\_\_

\_\_\_\_\_

\_\_\_\_\_

\_\_\_\_\_

\_\_\_\_\_

\_\_\_\_\_

\_\_\_\_\_

\_\_\_\_\_



**12.3 ANTENNA SYSTEM INSTALLATION CHECKLIST**

**SITE** \_\_\_\_\_  
**ANTENNA** \_\_\_\_\_  
**INSPECTED BY** \_\_\_\_\_  
**DATE** \_\_\_\_\_

**CHECKLIST:**

- 1. What is make of antenna? \_\_\_\_\_
- 2. What is type of antenna? \_\_\_\_\_
- 3. What is design gain of antenna? \_\_\_\_\_ dB
- 4. What is bearing of antenna? \_\_\_\_\_
- 5. What is height of antenna above ground? \_\_\_\_\_ Ft
- 6. Are hoisting grips installed as specified? \_\_\_\_\_
- 7. Is cable secured to tower at specified intervals? \_\_\_\_\_
- 8. Is cable grounded at top of tower? \_\_\_\_\_
- 9. Is cable grounded at bottom of tower? \_\_\_\_\_
- 10. Is cable grounded at point where it enters building? \_\_\_\_\_
- 11. Is cable feed-through properly installed? \_\_\_\_\_
- 12. Are coaxial connectors weather-sealed? \_\_\_\_\_
- 13. Is cable entrance weather-sealed? \_\_\_\_\_
- 14. Is there an AM mast within 2 miles of this site? \_\_\_\_\_

## 12.4 EQUIPMENT INSTALLATION CHECKLIST

SITE \_\_\_\_\_  
CABINET \_\_\_\_\_  
INSPECTED BY \_\_\_\_\_  
DATE \_\_\_\_\_

### CHECKLIST 1:

1. Verify that the cabinets are installed as located in the site plan drawing. \_\_\_\_\_
2. Verify each cabinet/rack is correctly fastened to the floor in all four (4) corners. \_\_\_\_\_
3. For cabinets, verify the optional cable ducts have been correctly installed. \_\_\_\_\_
4. For racks, verify all racks are bolted to adjacent rack at the top and bottom. \_\_\_\_\_
5. For cabinets, verify the top plate is correctly installed on the RF cabinet. \_\_\_\_\_
6. Verify the RF equipment is correctly installed. \_\_\_\_\_
7. Ensure all special installation requirements, provided by System Engineering, have been completed correctly. \_\_\_\_\_
8. Verify all metallic fixtures and room parts are connected to the internal ground HALO. \_\_\_\_\_
9. Verify the AC power is equipped with a Joselyn, or equivalent, AC protector in addition to all other AC power protection. \_\_\_\_\_
10. Verify all EDACS cabinets, cable trays, and/or cable duct systems are connected to the internal ground HALO. \_\_\_\_\_
11. Verify the GETC lightening circuitry is properly installed for each GETC. \_\_\_\_\_
12. Ensure all special installation requirements, provided by System Engineering, have been completed properly. \_\_\_\_\_

12.5 POWER SYSTEM INSTALLATION CHECKLIST

Table with 4 columns: System Name, YES/NO, SITE, and INSPECTED BY/DATE. Rows include AC SYSTEM, GENERATOR, AC/DC SYSTEM, BATTERY SYSTEM, and UPS SYSTEM.

CHECKLIST:

AC SYSTEM

- 1. Site isolation and protection is installed and operating
2. Input AC power, (voltage and current) is as specified
3. Input AC power breaker is correctly rated for the site power load
4. Input AC power cabling is sufficient for site loading
5. Customer's input AC power breaker operates correctly
6. AC distribution, voltages and individual breaker operation to equipments

GENERATOR SYSTEM

- 7. Generator, bypass switch and automatic switch-over operates correctly
8. Generator output voltages are as specified

AC / DC SYSTEM

- 9. Rectifier output to converters is as specified
10. Rectifier output breaker operates correctly
11. Converter output breakers operate correctly
12. Converter output voltages are as specified
13. Each associated equipment or cabinet is operating correctly

BATTERY SYSTEM

- 14. Battery system connectivity is correct as per design document
15. Battery system is electrically safe
16. "Wet" cells prepared and adequate fume extraction provided
17. Cabling is safely installed such that it is not a hazard
18. Output voltage is as specified across all the cells
19. Battery system will Charge
20. Battery power applied to power distribution equipments
21. Battery voltage applied to site equipment is as specified

UPS SYSTEM

- 22. UPS system installed to specifications and successfully completes all Vendor manual tests

**12.6 REPEATER TEST DATA**

CUSTOMER: \_\_\_\_\_ SITE NAME: \_\_\_\_\_

CHANNEL NUMBER: \_\_\_\_\_ TESTED BY: \_\_\_\_\_ DATE: \_\_\_\_\_

**REPEATER GENERAL IDENTIFICATION:**

MODEL NO.:	RX FCC ID #:	RX FREQUENCY (MHz):
SERIAL NO.:	TX FCC ID #:	TX FREQUENCY (MHz):

**P25 REPEATER IDENTIFICATION:**

SOURCE ID #:	TALK GROUP ID #:	TX NETWORK ACCESS CODE:
--------------	------------------	-------------------------

**STATION ALIGNMENT**

ALIGNMENT/TEST	POT	UNITS	LEVEL	POT VALUE
LINE INPUT	LI			
CHANNEL GUARD	CG	Hz	_____	_____
TRANSMIT LIMITING	TX	kHz	_____	_____
REPEATER GAIN	RG	kHz	_____	_____
DSP LINE INPUT	DLI	kHz	_____	_____
COMPRESSOR GAIN	CP	kHz	_____	_____
COMPRESSOR THRESHOLD	CT	kHz	_____	_____
DSP CANCELLATION	DC		_____	_____
LINE OUTPUT	LO	dBm	_____	_____
SENSITIVITY @ 12 dB SINAD	SINAD	dB	_____	_____
SQUELCH	SQUELCH	dB	_____	_____
TRANSMIT FORWARD POWER	PA	Watts	_____	_____
TRANSMIT REVERSE POWER		Watts	_____	_____

## 12.7 PREVENTATIVE MAINTENANCE REPEATER TEST DATA

REPEATER # _____						
Alignment/Test		Pot	Required Value	Measured Value	Adjusted Value	Pot Value
Channel Guard	WB	CG	750 ± 25 Hz			
	NPSPAC		600 ± 25 Hz			
	NB		500 ± 25 Hz			
	P25		500 ± 25 Hz			
Transmit Limiting	WB	TX	4.50 ± 0.1 kHz			
	NPSPAC		3.60 ± 0.1 kHz			
	NB		2.25 ± 0.1 kHz			
	P25		2.25 ± 0.1 kHz			
Repeater Gain (CG Disabled)	WB	RG	3.00 ± 0.1 kHz			
	NPSPAC		2.40 ± 0.1 kHz			
	NB		1.50 ± 0.1 kHz			
	P25		1.50 ± 0.1 kHz			
DSP Line Input Deviation (CG Disabled)	WB	DLI	2.80 ± 0.1 kHz			
	NPSPAC		2.25 ± 0.1 kHz			
	NB		1.40 ± 0.1 kHz			
	P25		1.40 ± 0.1 kHz			
Compressor Gain (CG Disabled)	WB	CP	3.00 ± 0.1 kHz			
	NPSPAC		2.40 ± 0.1 kHz			
	NB		1.50 ± 0.1 kHz			
	P25		1.50 ± 0.1 kHz			
Compressor Threshold	WB	CT	4.00 ± 0.1 kHz			
	NPSPAC		3.20 ± 0.1 kHz			
	NB		2.00 ± 0.1 kHz			
	P25		2.00 ± 0.1 kHz			
Repeater Line Output Level		LO	+11 to -20 dBm			
DSP Line Input Level		LI	+11 to -20 dBm			
SINAD			12 dB			
Squelch		Squelch	10 dB			
Transmit Forward Power		PA	50-100% Watts			
Transmit Reverse Power			<4 Watts			

INSPECTED BY \_\_\_\_\_

DATE \_\_\_\_\_

**M/A-COM Wireless Systems**

221 Jefferson Ridge Parkway

Lynchburg, Virginia 24501

(Outside USA, 434-385-2400) Toll Free 800-528-7711

<http://www.macom-wireless.com/>

Printed in U.S.A.