

Rhein Tech Laboratories, Inc.
360 Herndon Parkway
Suite 1400
Herndon, VA 20170
<http://www.rheintech.com>

Client: Harris Corporation
Model: XG-75 UHF-L 5W
IDs: OWDTR-0070-E/3636B-0070
Standards: FCC Part 90/IC RSS-119
Report #: 2011098

Appendix M: Manual

Please refer to the following pages.



XG-75 Series Portable Radios



REV	DATE	REASON FOR REVISION
-	Aug/11	Initial release.

Harris Corporation, Public Safety and Professional Communications (PSPC) Business continually evaluates its technical publications for completeness, technical accuracy, and organization. You can assist in this process by submitting your comments and suggestions to the following:

Harris Corporation
 PSPC Business or fax your comments to: 1-434-455-6851
 Technical Publications
 221 Jefferson Ridge Parkway or e-mail us at: PSPC-techpubs@harris.com
 Lynchburg, VA 24501

ACKNOWLEDGEMENTS

The software contained in this device is copyrighted by Harris Corporation. Unpublished rights are reserved under the copyright laws of the United States.

This device is made under license under one or more of the following US patents: 4,590,473; 4,636,791; 5,148,482; 5,185,796; 5,271,017; 5,377,229; 4,716,407; 4,972,460; 5,502,767; 5,146,497; 5,164,986; 5,185,795; 5,226,084; 5,247,579; 5,491,772; 5,517,511; 5,630,011; 5,649,050; 5,701,390; 5,715,365; 5,754,974; 5,826,222; 5,870,405; 6,161,089; and 6,199,037 B1. DVSI claims certain rights, including patent rights under aforementioned U.S. patents, and under other U.S. and foreign patents and patents pending. Any use of this software or technology requires a separate written license from DVSI.

CREDITS!

Harris, assuredcommunications, OpenSky, and EDACS are registered trademarks and ProScan and Failsoft are trademarks of Harris Corporation.

RBRC and 1-800-8-BATTERY are registered trademarks of Rechargeable Battery Recycling Corporation.

AMBE is a registered trademark and IMBE, AMBE+, and AMBE+2 are trademarks of Digital Voice Systems, Inc.

All other product and brand names are trademarks, registered trademarks, or service marks of their respective holders.

NOTICE!

The material contained herein is subject to U.S. export approval. No export or re-export is permitted without written approval from the U.S. Government. Rated: EAR99; in accordance with U.S. Dept. of Commerce regulations 15CFR774, Export Administration Regulations.

Information and descriptions contained herein are the property of Harris Corporation. Such information and descriptions may not be copied or reproduced by any means, or disseminated or distributed without the express prior written permission of Harris Corporation, PSPC Business, 221 Jefferson Ridge Parkway, Lynchburg, VA 24501.

This manual covers Harris Corporation products manufactured and sold by Harris Corporation.



This product conforms to the European Union WEEE Directive 2002/96/EC. Do not dispose of this product in a public landfill. Take it to a recycling center at the end of its life.

The voice coding technology embodied in this product is protected by intellectual property rights including patent rights, copyrights, and trade secrets of Digital Voice Systems, Inc. The user of this technology is explicitly prohibited from attempting to decompile, reverse engineer, or disassemble the Object Code, or in any other way convert the Object Code into human-readable form.

Repairs to this equipment should be made only by an authorized service technician or facility designated by the supplier. Any repairs, alterations, or substitution of recommended parts made by the user to this equipment not approved by the manufacturer could void the user's authority to operate the equipment in addition to the manufacturer's warranty.

This manual is published by **Harris Corporation** without any warranty. Improvements and changes to this manual necessitated by typographical errors, inaccuracies of current information, or improvements to programs and/or equipment, may be made by **Harris Corporation** at any time and without notice. Such changes will be incorporated into new editions of this manual. No part of this manual may be reproduced or transmitted in any form or by any means, electronic or mechanical, including photocopying and recording, for any purpose, without the express written permission of **Harris Corporation**.

TABLE OF CONTENTS

	<i>Page</i>
1 SAFETY CONVENTIONS.....	6
2 SAFETY TRAINING INFORMATION	7
2.1 RF EXPOSURE GUIDELINES	7
2.2 ELECTROMAGNETIC INTERFERENCE/COMPATIBILITY	8
2.3 REGULATORY APPROVALS	9
2.3.1 Part 15.....	9
2.3.2 Industry Canada.....	9
3 OPERATING TIPS	10
3.1 EFFICIENT RADIO OPERATION	10
3.2 ANTENNA CARE AND REPLACEMENT.....	10
3.3 ELECTRONIC DEVICES.....	10
3.4 AIRCRAFT	11
3.5 ELECTRIC BLASTING CAPS	11
3.6 POTENTIALLY EXPLOSIVE ATMOSPHERES	11
4 BATTERIES	12
4.1 CONDITIONING BATTERY PACKS.....	12
4.1.1 Conditioning NiMH Battery Packs.....	12
4.1.2 Additional Information.....	12
4.2 CHARGING BATTERY PACKS	12
4.3 BATTERY PACK USAGE.....	13
4.4 CHANGING THE BATTERY PACK.....	13
4.4.1 Removing the Battery Pack	13
4.4.2 Attaching the Battery Pack	14
4.5 BATTERY DISPOSAL.....	15
5 INTRODUCTION	15
6 OPTIONS AND ACCESSORIES	16
7 USER INTERFACE	18
7.1 CONTROLS	18
7.1.1 Buttons, Knobs, and Switch	19
7.1.2 Keypad.....	20
7.2 DISPLAY	21
7.3 TRI-COLOR LED	22
7.4 UNIVERSAL DEVICE CONNECTOR.....	23
7.5 NOISE CANCELLATION.....	23
7.5.1 Turning Noise Cancellation On and Off.....	23
7.5.2 Using Noise Cancellation	24
7.5.3 The Effect of Distance from the Microphone.....	24
7.5.4 Primary versus Secondary Microphone.....	24
8 OPERATION	25
8.1 TURNING ON THE RADIO	25
8.2 STATUS MESSAGES (EDACS AND P25 TRUNKED).....	25
8.3 ERROR MESSAGES	26
8.4 ALERT TONES	26
8.5 SYSTEM SELECTION.....	27
8.6 GROUP/CHANNEL SELECTION.....	27

TABLE OF CONTENTS

	<i>Page</i>
8.7 MODIFY SCAN LIST	28
8.7.1 System Model Radio.....	28
8.7.2 Scan Model Radio	28
8.8 MENU	28
8.8.1 Menu Item Selection Process.....	29
8.9 BACKLIGHT ADJUST	31
8.10 CONTRAST ADJUST	31
8.11 DECLARE AN EMERGENCY	31
8.12 LOCKING/UNLOCKING KEYPAD	32
8.13 HIGH/LOW POWER ADJUSTMENT	32
8.14 ENCRYPTION	32
8.14.1 Displaying the Currently Used Cryptographic Key Number.....	32
8.14.2 Key Zero	33
8.14.3 Receiving an Encrypted Call	33
8.14.4 Transmitting an Encrypted Call.....	33
8.15 SCANNING TRUNKED GROUPS	33
8.15.1 Turning Scan On and Off	34
8.15.2 Adding Groups to a Scan List.....	34
8.15.3 Deleting Groups from a Scan List	35
8.15.4 Nuisance Delete	35
8.16 SCANNING TRUNKED SYSTEMS.....	36
8.16.1 Wide Area System Scanning	36
8.16.2 Priority System Scan.....	36
8.16.3 ProScan.....	37
8.17 EMERGENCY OPERATION.....	37
8.17.1 Receiving an Emergency Call	37
8.17.2 Declaring an Emergency Call.....	37
8.18 INDIVIDUAL CALLS	37
8.18.1 Receiving and Responding to an Individual Call	37
8.18.2 Sending an Individual Call	39
8.18.3 Call Storage Lists.....	39
8.19 TELEPHONE INTERCONNECT CALLS	40
8.19.1 Receiving a Telephone Interconnect Call.....	40
8.19.2 Sending a Telephone Interconnect Call.....	40
8.19.3 Dual-Tone Multi-Frequency: Overdial.....	41
8.20 PRE-STORING INDIVIDUAL AND TELEPHONE INTERCONNECT CALLS FROM THE KEYPAD.....	42
8.21 STATUS/MESSAGE OPERATION	43
8.21.1 Status Operation	43
8.21.2 Message Operation	43
8.22 DYNAMIC REGROUP OPERATION (EDACS)	44
8.22.1 Emergency Operation	44
8.23 MACRO KEY OPERATION.....	44
8.24 DATA COMMUNICATIONS	44
8.24.1 Displays	45
8.24.2 Data Off Operation	45
8.24.3 Data On Operation.....	45
8.24.4 Exiting Data Calls.....	45

TABLE OF CONTENTS

	<u>Page</u>
8.24.5 Scan Lockout Mode.....	45
8.24.6 Data Lockout Mode.....	46
8.25 SELECTIVE SIGNALING (CONVENTIONAL).....	46
8.25.1 Type 99 Operation.....	46
8.25.2 Type 99 with or without Channel Guard.....	46
8.25.3 Resetting Type 99 after a Call.....	47
8.25.4 Type 99 Disable after PTT.....	47
9 PREVENTIVE MAINTENANCE.....	48
9.1 IMMERSIBLE PREVENTIVE MAINTENANCE.....	48
9.2 BASIC TROUBLESHOOTING.....	48
10 CUSTOMER SERVICE.....	50
10.1 CUSTOMER CARE.....	50
10.2 TECHNICAL ASSISTANCE.....	50
FIGURES	
Figure 4-1: Removing the Battery Pack.....	14
Figure 4-2: Attaching the Battery Pack.....	14
Figure 7-1: Top View.....	18
Figure 7-2: Side View.....	18
Figure 7-3: Scan Model Front Panel.....	20
Figure 7-4: System Model Front Panel.....	20
Figure 7-5: XG-75 Radio Display.....	21
Figure 7-6: Tri-Color LED.....	22
Figure 7-7: XG-75 15-Pin Universal Device Connector.....	23
Figure 7-8: Using the Noise Cancellation Feature.....	24
Figure 8-1: Menu Display.....	28
Figure 8-2: Backlight Menu Item Selection Parameter.....	29
Figure 8-3: Backlight Menu Display.....	29
Figure 8-4: System Encryption Key Display.....	32
Figure 8-5: Group/Channel Encryption Key Display.....	33
Figure 8-6: Calls Received Lists.....	38
Figure 8-7: WHC Individual Call Display.....	38
Figure 8-8: Calls Received and Personality Lists.....	40
Figure 9-1: Labels.....	48
TABLES	
Table 2-1: RF Exposure Compliance Testing Distances.....	8
Table 2-2: Distance from Body for Different Carrying Options.....	8
Table 6-1: Options and Accessories.....	16
Table 7-1: Buttons, Knobs, and Switch Functions.....	19
Table 7-2: XG-75 Front Keypad Functions.....	20
Table 7-3: Status Icons Descriptions.....	21
Table 8-1: Alert Tones.....	26
Table 8-2: Menu Item Information.....	30
Table 8-3: Information Display.....	31
Table 9-1: Troubleshooting.....	49

1 SAFETY CONVENTIONS

The following conventions are used throughout this manual to alert the user to general safety precautions that must be observed during all phases of operation, service, and repair of this product. Failure to comply with these precautions or with specific warning elsewhere in this manual violates safety standards of design, manufacture, and intended use of the product. Harris Corporation assumes no liability for the customer's failure to comply with these standards.



The **WARNING** symbol calls attention to a procedure, practice, or the like, which, if not correctly performed or adhered to, could result in personal injury. Do not proceed beyond a **WARNING** symbol until the conditions identified are fully understood or met.



The **CAUTION** symbol calls attention to an operating procedure, practice, or the like, which, if not performed correctly or adhered to, could result in damage to the equipment or severely degrade the equipment performance.



The **NOTE** symbol calls attention to supplemental information, which may improve system performance or clarify a process or procedure.



The **ESD** symbol calls attention to procedures, practices, or the like, which could expose equipment to the effects of Electro-Static Discharge. Proper precautions must be taken to prevent ESD when handling circuit modules.



WARNING - The electrical hazard symbol indicates there is an electrical hazard present.

2 SAFETY TRAINING INFORMATION



The Harris XG-75 portable radio generates RF electromagnetic energy during transmit mode. This radio is designed for and classified as “Occupational Use Only,” meaning it must be used only during the course of employment by individuals aware of the hazards and the ways to minimize such hazards. This radio is NOT intended for use by the “General Population” in an uncontrolled environment.

The XG-75 portable radio has been tested and complies with the FCC RF exposure limits for “Occupational Use Only.” In addition, this Harris radio complies with the following Standards and Guidelines with regard to RF energy and electromagnetic energy levels and evaluation of such levels for exposure to humans:

- FCC OET Bulletin 65 Edition 97-01 Supplement C, Evaluating Compliance with FCC Guidelines for Human Exposure to Radio Frequency Electromagnetic Fields.
- American National Standards Institute (C95.1 – 1992), IEEE Standard for Safety Levels with Respect to Human Exposure to Radio Frequency Electromagnetic Fields, 3 kHz to 300 GHz.
- American National Standards Institute (C95.3 – 1992), IEEE Recommended Practice for the Measurement of Potentially Hazardous Electromagnetic Fields – RF and Microwave.

2.1 RF EXPOSURE GUIDELINES



To ensure that exposure to RF electromagnetic energy is within the FCC allowable limits for occupational use, always adhere to the following guidelines:

- DO NOT operate the radio without a proper antenna attached, as this may damage the radio and may also cause the FCC RF exposure limits to be exceeded. A proper antenna is the antenna supplied with this radio by Harris or an antenna specifically authorized by Harris for use with this radio. (Refer to Table 6-1.)
- DO NOT transmit for more than 50% of total radio use time (“50% duty cycle”). Transmitting more than 50% of the time can cause FCC RF exposure compliance requirements to be exceeded. The radio is transmitting when the “TX” indicator appears in the display. The radio will transmit by pressing the “PTT” (Push-To-Talk) button.
- ALWAYS transmit using low power when possible. In addition to conserving battery charge, low power can reduce RF exposure.
- ALWAYS use Harris authorized accessories (antennas, batteries, belt clips, speaker/mics, etc). Use of unauthorized accessories may cause the FCC Occupational/Controlled Exposure RF compliance requirements to be exceeded. (Refer to Table 2-1.)

- As noted in Table 2-1, ALWAYS keep the device and its antenna **AT LEAST** 1.6 cm (0.63 inches) from the body and at least 2.5 cm (1.0 inch) from the face when transmitting to ensure FCC RF exposure compliance requirements are not exceeded. However, to provide the best sound quality to the recipients of your transmission, Harris recommends you hold the microphone at least 5 cm (2 inches) from mouth, and slightly off to one side.

Table 2-1: RF Exposure Compliance Testing Distances

RADIO FREQUENCY	TESTED DISTANCES (worst case scenario)	
	Body	Face
VHF (136 - 174 MHz)	1.6 cm	2.5 cm
UHF-L (378-403MHz)	1.6 cm	2.5 cm

Table 2-2: Distance from Body for Different Carrying Options

CARRYING CONFIGURATION	TESTED DISTANCES (worst case from body)
Belt Loop	4.2 cm
Belt Clip	1.8 cm
Leather Case with Belt Loop	5.2 cm
Nylon Case with Belt Loop	4.5 cm
Shoulder Strap with D-clip	3.0 cm
Speaker-microphone with antenna	1.6 cm

The information in this section provides the information needed to make the user aware of RF exposure, and what to do to assure that this radio operates within the FCC RF exposure limits of this radio.

2.2 ELECTROMAGNETIC INTERFERENCE/COMPATIBILITY

During transmissions, this Harris radio generates RF energy that can possibly cause interference with other devices or systems. To avoid such interference, turn off the radio in areas where signs are posted to do so. DO NOT operate the transmitter in areas that are sensitive to electromagnetic radiation such as hospitals, aircraft, and blasting sites.

2.3 REGULATORY APPROVALS

2.3.1 Part 15

This device complies with Part 15 of the FCC Rules. Operation is subject to the following two conditions:

1. This device may not cause harmful interference, and
2. This device must accept any interference received, including interference that may cause undesired operation.

2.3.2 Industry Canada

This device complies with Industry Canada license-exempt RSS standard(s). Operation is subject to the following two conditions: (1) this device may not cause interference, and (2) this device must accept any interference, including interference that may cause undesired operation of the device.

Le présent appareil est conforme aux CNR d'Industrie Canada applicables aux appareils radio exempts de licence. L'exploitation est autorisée aux deux conditions suivantes : (1) l'appareil ne doit pas produire de brouillage, et (2) l'utilisateur de l'appareil doit accepter tout brouillage radioélectrique subi, même si le brouillage est susceptible d'en compromettre le fonctionnement.

3 OPERATING TIPS

Antenna location and condition are important when operating a portable radio. Operating the radio in low lying areas or terrain, under power lines or bridges, inside of a vehicle or in a metal framed building can severely reduce the range of the unit. Mountains can also reduce the range of the unit.

In areas where transmission or reception is poor, some improvement may be obtained by ensuring that the antenna is vertical. Moving a few yards in another direction or moving to a higher elevation may also improve communications. Vehicular operation can be aided with the use of an externally mounted antenna.

Battery condition is another important factor in the trouble free operation of a portable radio. Always properly charge the batteries.

3.1 EFFICIENT RADIO OPERATION

Keep the antenna in a vertical position when receiving or transmitting a message.

Do not hold the antenna when receiving a message and, especially, do not hold when transmitting a message.



Do NOT hold onto the antenna when the radio is powered on!

3.2 ANTENNA CARE AND REPLACEMENT



Do not use the portable radio with a damaged or missing antenna. A minor burn may result if a damaged antenna comes into contact with the skin. Replace a damaged antenna immediately. Operating a portable radio with the antenna missing could cause personal injury, damage the radio, and may violate FCC regulations.



Use only the supplied or approved antenna. Unauthorized antennas, modifications, or attachments could cause damage to the radio unit and may violate FCC regulations. (Refer to Table 6-1.)

3.3 ELECTRONIC DEVICES



RF energy from portable radios may affect some electronic equipment. Most modern electronic equipment in cars, hospitals, homes, etc. is shielded from RF energy. However, in areas in which you are instructed to turn off two-way radio equipment, always observe the rules. If in doubt, turn it off!

3.4 AIRCRAFT



- Always turn off a portable radio before boarding any aircraft!
- Use it on the ground only with crew permission.
- **DO NOT** use while in-flight!!

3.5 ELECTRIC BLASTING CAPS



To prevent accidental detonation of electric blasting caps, **DO NOT** use two-way radios within 1000 feet of blasting operations. Always obey the "Turn Off Two-Way Radios" signs posted where electric blasting caps are being used. (OSHA Standard: 1926.900)

3.6 POTENTIALLY EXPLOSIVE ATMOSPHERES



Areas with potentially explosive atmospheres are often, but not always, clearly marked. These may be fuelling areas, such as gas stations, fuel or chemical transfer or storage facilities, and areas where the air contains chemicals or particles, such as grain, dust, or metal powders.

Sparks in such areas could cause an explosion or fire resulting in bodily injury or even death.

Turn off two-way radios when in any area with a potentially explosive atmosphere. It is rare, but not impossible that a radio or its accessories could generate sparks.

4 BATTERIES

The XG-75 series portable radios use rechargeable, recyclable Nickel Metal Hydride (NiMH) or Lithium-Ion (Li-Ion) batteries. Please read carefully, the battery information provided, to maximize the useful life of each type of battery.



Do not disassemble or modify Lithium Ion battery packs. The Lithium Ion battery packs are equipped with built-in safety and protection features. Should these features be disabled or tampered with in any way, the battery pack can leak electrolyte, overheat, emit smoke, burst, and/or ignite.



If the battery is ruptured or is leaking electrolyte that results in skin or eye contact with the electrolyte, immediately flush the affected area with water. If the battery electrolyte gets in the eyes, flush with water for 15 minutes and consult a physician immediately.

4.1 CONDITIONING BATTERY PACKS

4.1.1 Conditioning NiMH Battery Packs

Condition a new NiMH battery before putting into use. This also applies to rechargeable NiMH batteries that have been stored for long periods (weeks, months, or longer). Conditioning requires fully charging and fully discharging the battery three (3) times using the tri-chemistry charger. The first time the battery is put into the charger, this unit will condition Nickel-based battery packs by automatically charging and discharging (cycling) the battery. Refer to the appropriate charger manual for details.



Failure to properly condition NiMH battery packs before initial use will result in shortened performance by the battery.

4.1.2 Additional Information

For more information regarding the proper care of portable radio batteries or establishing a battery maintenance program, refer to ECR-7367. To order, call toll free at 1-800-368-3277, then select option 7.

4.2 CHARGING BATTERY PACKS

Battery chargers are available from Harris with nominal charge times. Combinations include single and multi-position charge units.

Harris chargers are specifically designed for charging nickel-based and lithium ion battery packs. The chargers are chemistry-specific for the battery packs and automatically adjust the charging profiles accordingly. Refer to the appropriate charger manual for specific operating instructions.

Observe the following guidelines when charging a battery pack:

- Avoid high temperature during charging.

- Discontinue use if the charger is overheating.
- Only charge Harris battery packs using a charger approved for use by Harris.
- Do not leave batteries in the charger indefinitely. For best results, leave the battery in the charger for two to six hours after the Green Ready LED comes on. Then place the battery pack into service and fully discharge (as indicated by the radio low battery warning) before re-charging.

If any faults are encountered while charging the battery pack, consult the charger's manual to determine the cause and possible corrective action.

4.3 BATTERY PACK USAGE

Both Nickel-based and Lithium ion batteries vary in capacity and life cycle. Nickel-based and Lithium-ion type batteries require basic usage guidelines be followed in order to optimize the battery runtime or shift life.

The following guidelines will help optimize the battery runtime or shift life:

- Ensure Nickel-based battery packs are fully discharged (as indicated by the radio low battery warning) before re-charging. Full discharge is not required for Lithium Ion battery packs.
- Periodically condition Nickel-based battery packs. The frequency should be determined based on usage patterns (refer to ECR-7367). If the battery is fully discharged (to radio Low Battery warning) during routine use, the frequency of conditioning may be reduced. Lithium Ion batteries do not suffer from memory-effect and therefore do not require conditioning.

Do not leave any Harris rechargeable batteries in a charger for more than a few days.

4.4 CHANGING THE BATTERY PACK

4.4.1 Removing the Battery Pack

Make sure the power to the radio is turned off.



Although the XG-75 has been designed to tolerate changing the battery pack without turning power off, Harris recommends turning the radio off before changing battery packs to ensure safety and best operation.

1. Press or pull both latches on either side of the battery pack ① toward the bottom of the radio simultaneously.
2. Pull the battery ② away from the radio.
3. Remove the battery pack from the radio.



Figure 4-1: Removing the Battery Pack

4.4.2 Attaching the Battery Pack

Make sure the power to the radio is turned off.

1. Align the tabs at each side on the bottom of the battery pack with the slots at the bottom of the battery cavity ①.
2. Push the top of the battery pack ② down until the latches click to attach the battery to the radio.
3. Tug gently to verify that the latches are secure and the battery pack is properly attached to the radio.



Figure 4-2: Attaching the Battery Pack

4.5 BATTERY DISPOSAL



In no instance should a battery be incinerated. Disposing of a battery by burning will cause an explosion.



RECHARGEABLE BATTERY PACK DISPOSAL – The product you have purchased contains a rechargeable battery. The battery is recyclable. At the end of its useful life, under various state and local laws, it may be illegal to dispose of this battery into the municipal waste stream. Check with your local solid waste officials for details in your area for recycling options or proper disposal. Canadian and U.S. users may call Toll Free 1-800-8-BATTERY® for information and/or procedures for returning rechargeable batteries in your locality.

5 INTRODUCTION

The XG-75 is available in two models: the Scan model with a limited 6-button front-mounted keypad and the System model with a 15-button DTMF front-mounted keypad. The Harris XG-75 portable radio delivers end-to-end encrypted digital voice and IP data communications. It is designed to support multiple operating modes including:

- EDACS® (Enhanced Digital Access Communications System) or ProVoice™ Trunked Modes
- P25 Trunked Mode
- P25 Digital Conventional Mode
- Conventional Analog Mode

The XG-75 portables can include all of these modes or just one. Additional modes of operation can be added with software updates.

The XG-75 supports a full range of advanced digital trunking features, including talk group calls, priority scanning, emergency calls, late call entry, and dynamic reconfiguration. It performs autonomous roaming for wide area applications. High quality voice coding and robust audio components assure speech clarity.

In the trunked modes, the user selects a communications “operating” system (i.e., EDACS, ProVoice, or P25) and group. While communicating in a trunked mode, channel selection is transparent to the user and is controlled via digital communication with the system controller (e.g., a CSD in an EDACS system). This provides advanced programmable features and fast access to communication channels.

In Conventional Analog mode, the user selects a channel and communicates directly on that channel. A channel is a transmit/receive radio frequency pair.

The exact operation of the radio will depend on the operating mode, the radio’s programming, and the particular radio system. Most features described in this manual can be enabled through programming. Consult your System Administrator for the particular features programmed into your XG-75. Then refer to the corresponding section(s) within this manual for feature and operation information.

The XG-75 series portable radios operate reliably even under adverse conditions. These radios meet MIL-STD-810G specifications for wind driven rain, humidity, and salt fog.

6 OPTIONS AND ACCESSORIES

Table 6-1 lists the Options and Accessories tested for use with the XG-75 series portable radios.

Refer to the maintenance manual corresponding to the frequency of your XG-75 or to Harris Products and Services Catalog for a complete list of options and accessories, including those items that do not adversely affect the RF energy exposure.



Always use Harris authorized accessories (antennas, batteries, belt clips, speaker/mics, etc). Use of unauthorized accessories may cause the FCC Occupational/Controlled Exposure RF compliance requirements to be exceeded. (Refer to Table 2-1.)



Always use the correct options and accessories (battery, antenna, speaker/mic, etc.) for the radio. Immersion rated options must be used with an immersion rated radio. Factory Mutual options must be used with Factory Mutual certified radios. (Refer to Table 6-1.)

Table 6-1: Options and Accessories

DESCRIPTION	PART NUMBER
ANTENNAS	
Helical coil (136-151 MHz)	KRE 101 1219/1
Helical coil (150-162 MHz)	KRE 101 1219/2
Helical coil (162-174 MHz)	KRE 101 1219/3
Helical coil (150-174 MHz)	KRE 101 1219/21
Helical stub (378-403 MHz)	KRE 101 1219/9
Helical stub (403-430 MHz)	KRE 101 1219/10
1/4 - wave whip (378-430 MHz)	KRE 101 1223/10
1/4 - wave whip (430-470 MHz)	KRE 101 1223/12
Helical stub (430-470 MHz)	KRE 101 1219/12
Helical stub (470-512 MHz)	KRE 101 1219/14
1/4 - wave whip (450-512 MHz)	KRE 101 1223/12
Wideband whip (764-870 MHz)	KRE 101 1506/02
1/2 - wave (764-870 MHz)	KRE 101 1506/01
BATTERIES (IMMERSION-RATED)	
NiMH, immersible, Goldpeak cells, non-IS	BT-023406-103
Nickel Metal Hydride (NiMH) Battery, Immersible, non-[FM]	BT-023406-003
Nickel Metal Hydride (NiMH) Battery, Immersible, [FM]	BT-023406-004
Lithium Ion (Li-Ion) Battery, Immersible, non-[FM]	BT-023406-005
MISCELLANEOUS ACCESSORIES	
Speaker Mic without Antenna (cc) provision, [FM]	MC-023933-001
Speaker Mic with Antenna (cc) provision, [FM]	MC-023933-002
Earphone for Speaker Mic [FM]	LS103239V1
GPS, non-IS	MC-009104-002
Ruggedized Speaker Mic-Coil Cord	MC-011617-601
Standard Speaker Mic - Non Ant	MC-011617-701

DESCRIPTION	PART NUMBER
DROP SHIP AUDIO ACCESSORIES	
Earphone Kit, Black	EA-009580-001
Earphone Kit, Beige	EA-009580-002
2-Wire Kit, Palm Mic, Black	EA-009580-003
2-Wire Kit, Palm Mic, Beige	EA-009580-004
3-Wire Kit, Mini-Lapel Mic, Black	EA-009580-005
3-Wire Kit, Mini-Lapel Mic, Beige	EA-009580-006
Explorer Headset with PTT	EA-009580-007
Lightweight Headset Single Speaker with PTT	EA-009580-008
Breeze Headset with PTT	EA-009580-009
Headset, Heavy Duty, N/C Behind-the-Head, with PTT	EA-009580-010
Ranger Headset with PTT	EA-009580-011
Skull Mic with Body PTT and Earcup	EA-009580-012
Headset, Heavy Duty, N/C Over-the-Head, with PTT	EA-009580-013
Throat Mic with Acoustic Tube and Body PTT	EA-009580-014
Throat Mic with Acoustic Tube, Body PTT, and Ring PTT	EA-009580-015
Breeze Headset with PTT and Pigtail Jack	EA-009580-016
Hurricane Headset with PTT	EA-009580-017
Hurricane Headset with PTT and Pigtail Jack	EA-009580-018
CARRYING CASE ACCESSORIES	
Black Nylon Case with Belt Loop Kit, consists of: Black Nylon Case with Retaining Strap and Leather Belt Loop	Kit: KT-016201-001 , incl: FM-016199-001 CC-014527
Orange Nylon Case with Belt Loop Kit, consists of: Orange Nylon Case with Retaining Strap and Leather Belt Loop	Kit: KT-016201-002 , incl: FM-016199-002 CC-014527
Leather Case with Belt Loop Kit, consists of: Leather Case with Retaining Strap (w/o Shoulder Strap D-Rings), Swivel Mount and Leather Belt Loop	Kit: KT-016201-003 , incl: FM-016199-003 KRY 101 1608/2 CC-014527
Leather Case with Shoulder Strap Kit, consists of: Leather Case with Retaining Strap D-Rings with Retaining Strap, Swivel Mount Shoulder Strap	Kit: KT-016201-004 , incl: FM-016199-004 KRY 101 1608/2 CC-014524-001
Short Leather Retaining Strap (for use with Shoulder Strap application)	CC-014524-002
Metal Belt Clip	CC23894

7 USER INTERFACE

This section describes the primary user interface; the buttons, knob controls, indicators, switch, and display.

7.1 CONTROLS

The XG-75 portable radios feature two rotary control knobs, an emergency button, and a dual-position A/B switch located on the top of the radio (Figure 7-1). The Push-To-Talk (PTT) button and two option buttons are located on the side (Figure 7-2) of the radio. The front mounted keypad of the System model has 15 buttons and the Scan model has six buttons. Refer to Figure 7-3 and Figure 7-4, respectively.

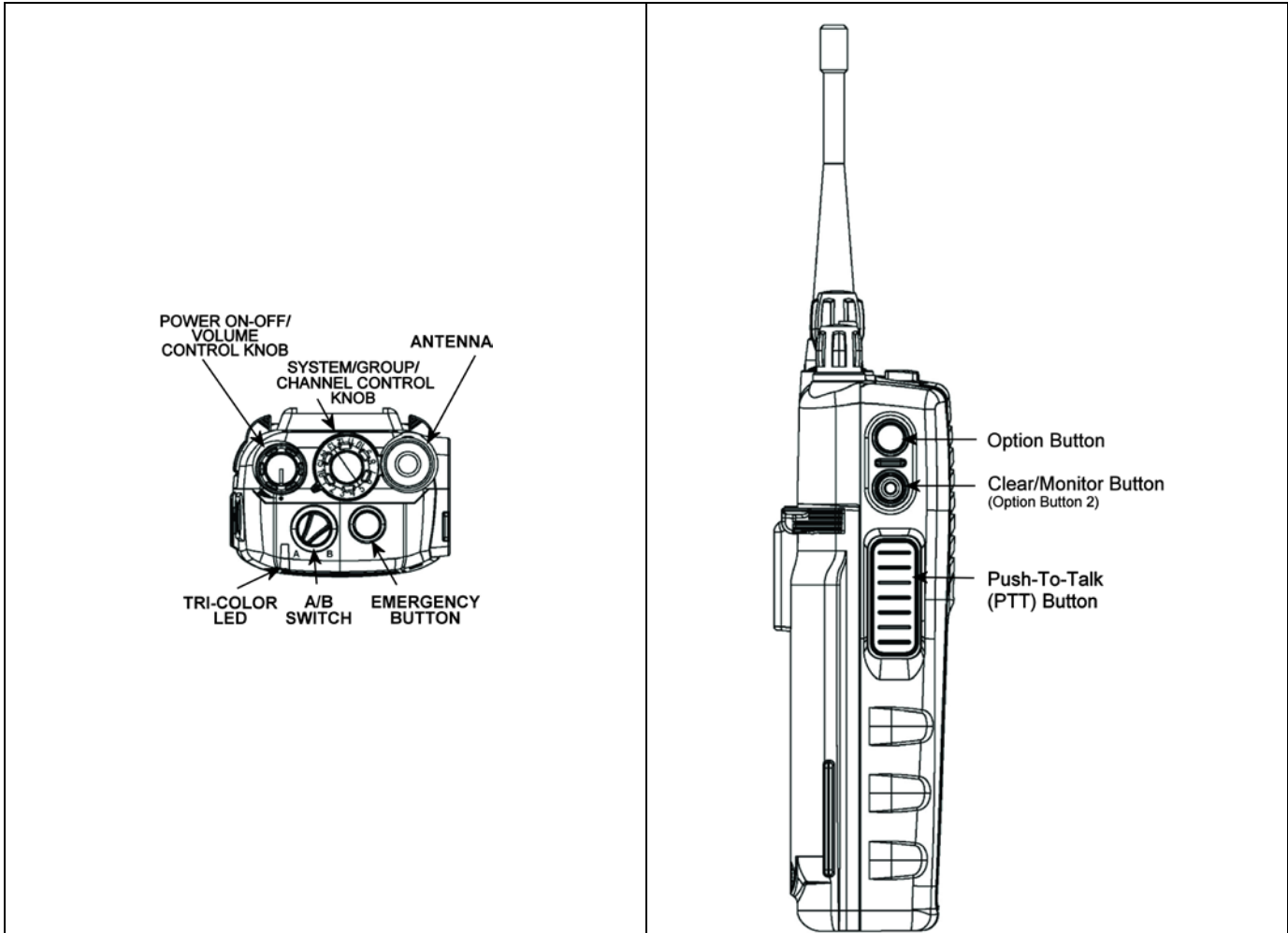



Figure 7-1: Top View

Figure 7-2: Side View

7.1.1 Buttons, Knobs, and Switch

The functions of the buttons and knob controls vary depending on mode of operation. The dual position A/B switch is currently software defined only in ECP mode. Primary functions of the button, switch, and knob controls are discussed in general terms in the following.

Table 7-1: Buttons, Knobs, and Switch Functions

POWER ON/OFF-VOLUME CONTROL KNOB	<p>Applies power to the radio and adjusts audio volume.</p> <p>Rotating the control clockwise applies power to the radio. If enabled through programming, a single alert tone indicates the radio is operational.</p> <p>Rotating the control clockwise increases the volume level. A minimum volume level can be programmed into the radio to prevent missed calls due to a low volume setting. While adjusting the volume, the display momentarily indicates the volume level (i.e., VOL=31). The volume ranges from a minimum programmable level of zero (displayed as OFF in the display) up to 40, which is the loudest level.</p>
SYSTEM/GROUP/CHANNEL CONTROL KNOB	<p>Used to select groups/channels. This is a 16-position rotary knob.</p> <p><i>Note:</i> A mechanical stop, used to limit the number of accessible positions, is shipped with the radio but must be installed. To install the mechanical stop, remove the System/Group/Channel control knob, loosen the set screw on the System/Group/Channel control knob metal base (using a 1.27 mm hex wrench), and remove the System/Group/Channel control knob metal base. Replace the 16 channel ring with the channel stop ring located at the desired channel. Re-install the System/Group/Channel control knob metal base, tighten the set screw, and re-install the System/Group/Channel control knob.</p>
EMERGENCY/HOME BUTTON	<p>Automatically selects a pre-programmed “Home” Group/System by pressing and holding for a programmed duration OR it can be used to declare an emergency by pressing and holding for a programmed duration. The button can be pre-programmed for either operation, but not both.</p>
PUSH-TO-TALK (PTT) BUTTON	<p>The PTT button is pressed before voice transmission begins.</p>
	<p>Activates one of a number of programmable software options selected during PC programming.</p>
	<p>Exits the current operation (removing all displays associated with it) and returns the radio to the selected talk group.</p>
A/B SWITCH	<p>The function of the dual-position A/B switch is user-defined from a list of programmable options.</p>

7.1.2 Keypad

The front mounted keypad of the Scan model has six buttons and System model has 15 buttons. Refer to Figure 7-3 and Figure 7-4, respectively.

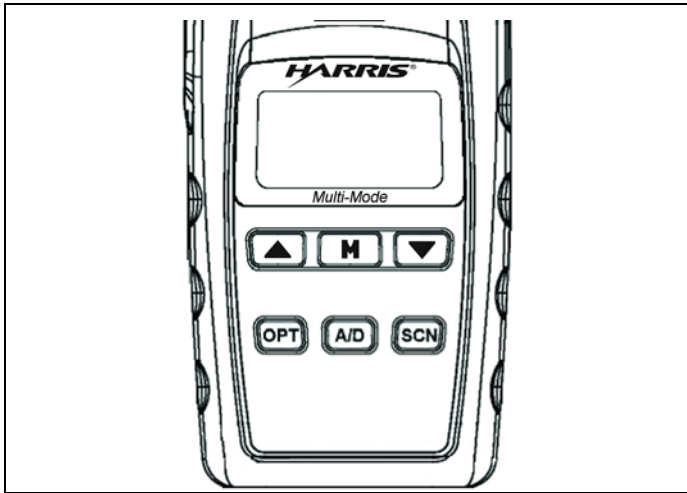

Figure 7-3: Scan Model Front Panel



Figure 7-4: System Model Front Panel

The primary and secondary functions of each key, where applicable, are described in Table 7-2 and the following section.

Table 7-2: XG-75 Front Keypad Functions

KEY	FUNCTION
	<u>Primary Function:</u> Accesses the menu. <u>Secondary Function:</u> Activates a selected item within the menu, similar to an “Enter” key.
	<u>Primary Function:</u> Scrolls through available systems, groups, or channels, depending on personality programming. <u>Secondary Function:</u> Changes the selection for an item within a list.
	Adds/deletes selected groups or channels from the scan list of the currently selected system.
	Toggles scan operation on and off.
	Activates one of any programmable software options selected during radio programming, i.e., high/low TX power and talkaround.
	<u>Primary function:</u> Selects a specific system. If the rotary knob is used to select the system and more than 16 systems are programmed in the radio, the key is used to select additional banks (groupings) of systems.
	<u>Primary function:</u> Selects a specific group.
	<u>Primary function:</u> Turns the Scan operation on and off.
	<u>Primary function:</u> Enables or disables encryption for the system/group/channel displayed.
	<u>Primary function:</u> Adds groups or channels from the currently selected system to the scan list.

KEY	FUNCTION
	<u>Primary function:</u> The Status key accesses the status list (0-9) permitting the transmission of a pre-programmed status message to an EDACS or P25 site.
	<u>Primary function:</u> The Message key accesses the message list (0-9). The Message key permits the transmission of a pre-programmed message to an EDACS or P25 site.
	<u>Primary function:</u> Deletes selected groups or channels of the currently selected system from the Scan list.
 	<u>Secondary function:</u> The secondary function of these keys acts as a typical DTMF telephone pad, and are used to place telephone interconnect and individual (unit-to-unit) calls.
	<u>Primary function:</u> In EDACS and P25 modes, initiates telephone interconnect calls.
	<u>Primary function:</u> In EDACS and P25 modes, initiates individual, unit-to-unit calls.

7.2 DISPLAY

The XG-75 display is made up of 4 lines containing twelve alpha-numeric character blocks each. If programmed, the display backlighting will illuminate upon power up or when radio controls are operated. Specific display characteristics will be discussed in following sub-sections.

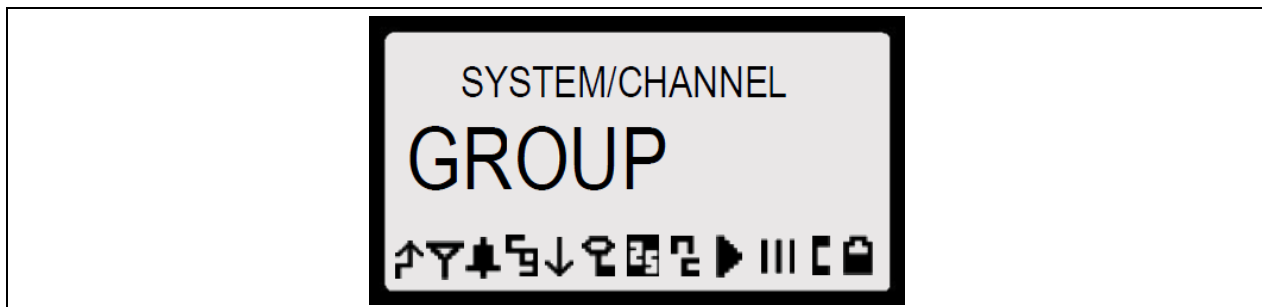

Figure 7-5: XG-75 Radio Display

Table 7-3 describes the icons that may be displayed by the XG-75 during operation.

Table 7-3: Status Icons Descriptions

ICON	DESCRIPTIONS
	Steady – during all radio transmissions.
	Steady – “Busy” transmitting or receiving, call queued.
	Steady – T99 Mode enabled.
	Steady – Channel Guard enabled If icon is not visible – Channel Guard is disabled.
	Steady – EDACS system in Failsoft™ mode.

ICON	DESCRIPTIONS
	Steady – transmit at low power. If icon is not visible – transmit at high power.
	Steady – transmit in encrypt mode. Flashing – receiving an encrypted call.
	Steady – Indicates the current channel is set up as a Project 25 (P25) channel.
	Steady – Indicates the current channel is set up as a ProVoice channel.
	Steady – Indicates the current channel is set up as an analog channel.
	Animated (rotates clockwise) – scan mode enabled. If icon is not visible – scan is disabled.
	Steady – priority 1 group or channel.
	Steady – priority 2 group or channel.
	Steady – group or channel in scan list.
	Steady – special call mode (individual or telephone).
	Steady – battery charge indicator. The battery charge indicators illustrate approximate level only, based on battery voltage.
	Flashing – Low battery indicator.
	Steady – Noise cancelling is enabled.

7.3 TRI-COLOR LED

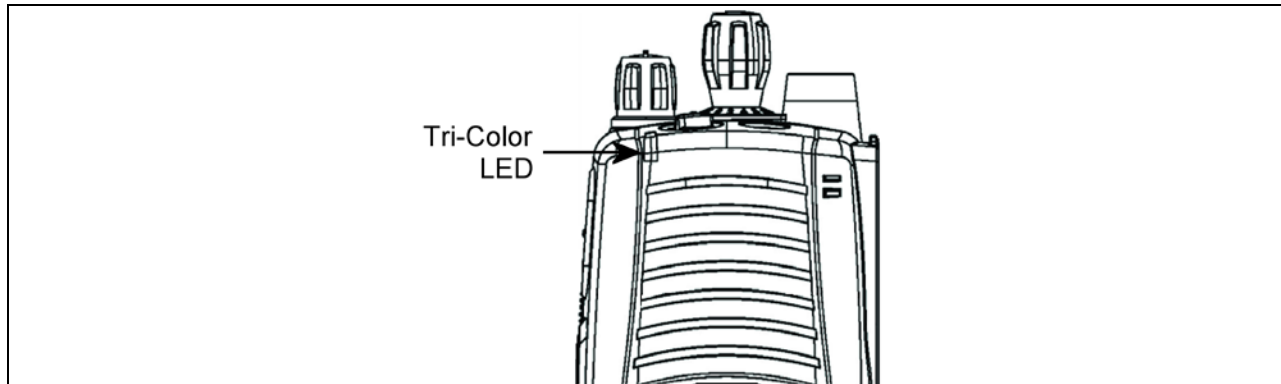

Figure 7-6: Tri-Color LED

The Tri-Color LED changes color to indicate radio status and is visible from both the front and top of the radio (see Figure 7-1). In addition, the mode of operation may also help determine what the color of the LED represents.

- Green:** Receiving
- Red:** Transmitting Unencrypted
- Orange:** Transmitting Encrypted

7.4 UNIVERSAL DEVICE CONNECTOR

The Universal Device Connector (UDC) provides connections for external accessories such as a headset, a speaker-microphone, audio test box, audio test cables, and programming cables. The UDC is located on the right side of the radio, opposite the PTT Button. The UDC facilitates programming and testing the radio. The UDC pins perform different functions depending on the accessory attached to the UDC.

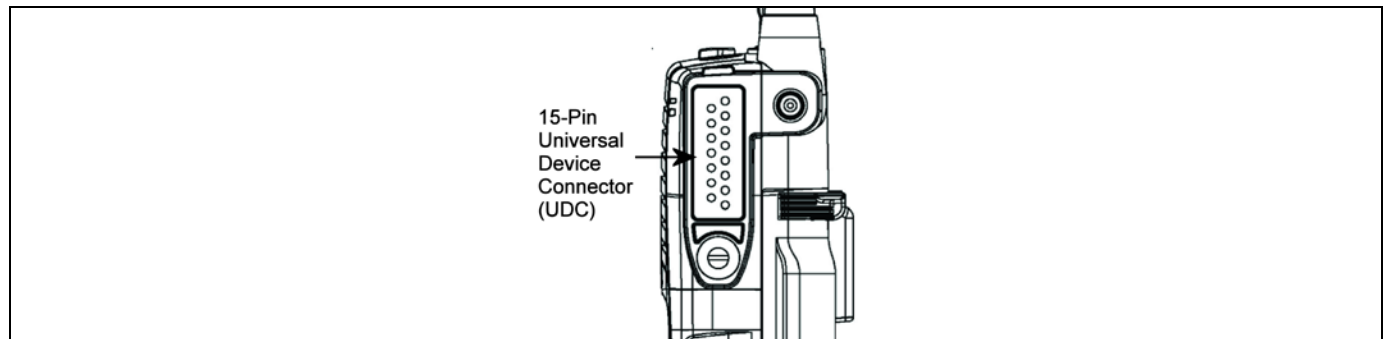

Figure 7-7: XG-75 15-Pin Universal Device Connector

7.5 NOISE CANCELLATION

The XG-75 features Harris' proprietary noise suppression capability to provide clear and crisp voice quality in high-noise environments for use in any mode, including both analog and digital communications.

The XG-75 has two microphones; one located on the front (primary) and one on the rear (secondary). The primary microphone operates in exactly the same manner as a normal radio and is the one you talk into. The secondary microphone is used to pick up the surrounding noise when noise cancellation is turned on.

In the case where noise cancellation is enabled and a speaker microphone is attached to the XG-75, talk into the speaker microphone. In this mode, XG-75 front microphone is used to pick up the surrounding noise, and the rear microphone is unused.

If the secondary microphone is blocked, the XG-75 operates as though noise cancellation is turned off.

7.5.1 Turning Noise Cancellation On and Off

A button on the radio or the A/B switch can be programmed to toggle noise cancellation on or off.

OR

1. Press the M button.
2. Use the ▲ or ▼ button to select "NOIS CAN."
3. Press the M again to toggle noise cancellation on or off.

The top line of the display will briefly display "NC ON" or "NC OFF." When noise cancellation is enabled, the  icon is displayed on the bottom of the display.

7.5.2 Using Noise Cancellation

When using the noise cancellation feature, observe the following:

- Talk within two (2) inches of primary microphone (see Figure 7-8).
- Speak clearly, loudly, and with authority.
- If possible, face the noise source when talking into the radio (see Figure 7-8).
- Ensure the primary and secondary microphones are not covered. See Section 7.5.4 for more information on the primary and secondary microphones.
- In very noisy environments, it is o.k. to yell into the radio. The radio can handle very loud input levels.

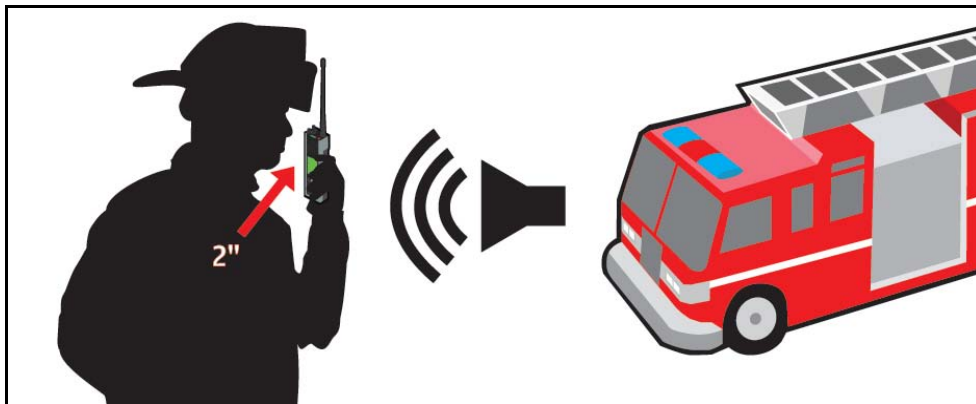

Figure 7-8: Using the Noise Cancellation Feature

7.5.3 The Effect of Distance from the Microphone

Unlike a normal microphone system, noise cancellation makes the level of your voice diminish quickly as you move away from the radio. In essence, the radio starts to see your voice as surrounding noise. Whereas, you may be comfortable speaking up to a foot away from the front of a normal radio, noise cancellation requires that you keep it close.

7.5.4 Primary versus Secondary Microphone

7.5.4.1 Without a Speaker Microphone Attached

The primary microphone is located on the front of the radio and the secondary is on the back of the radio.

7.5.4.2 With a Speaker Microphone Attached

When a speaker microphone is attached, the radio electronically switches over to use the radio's front microphone as secondary. The microphone on the attached speaker microphone becomes the primary microphone.

8 OPERATION

8.1 TURNING ON THE RADIO

1. Power on the radio by rotating the power on-off/volume knob clockwise. A short alert signal (if enabled through programming) indicates the radio is ready to use.
2. The display shows the last selected system and group or a default system and group (depending on programming).
3. Adjust the power on-off/volume knob to the desired volume level.
4. Select the desired system and group. The display indicates the current system and group names.
5. The radio is now ready to transmit and receive calls.



NOTE

In the trunked environment, CC SCAN is displayed if communication with the system's control channel cannot be established. This may occur if, for example, the radio is out of range of the trunking site. It may be necessary to move to another location or select another trunking system to re-establish the control channel link for trunked mode operations. CC SCAN is displayed on the group line until a control channel is accessed.

8.2 STATUS MESSAGES (EDACS AND P25 TRUNKED)

During radio operation, various radio Status Messages may be displayed. The messages are described below.

<u>MESSAGE</u>	<u>NAME</u>	<u>DESCRIPTION</u>
QUEUED	Call Queued	Indicates the system has placed the call in a request queue.
SYS BUSY	System Busy	Indicates the system is busy, no channels are currently available, the queue is full, or an individual call is being attempted to a radio that is currently transmitting.
DENIED	Call Denied	Indicates the radio or talkgroup is not authorized to operate on the selected system or talkgroup.
CC SCAN	Control Channel Scan	Indicates the control channel is lost and the radio has entered the Control Channel Scan mode to search for the control channel. This is usually an out of range indication.
WA SCAN	Wide Area Scan	Indicates the radio has entered the Wide Area Scan mode to search for a new system. Wide Area Scan mode must be enabled through programming.
SYSC ON	System Scan Features On	Indicates the System Scan features are enabled.
SYSC OFF	System Scan Features Off	Indicates the System Scan features are disabled.
LOW BATT	Low Battery	Battery voltage has dropped to the point where the radio is no longer able to transmit. The radio will still receive calls until the battery is discharged beyond the point of operation, at which time the radio automatically shuts down.

<u>MESSAGE</u>	<u>NAME</u>	<u>DESCRIPTION</u>
RXEMER	Receive Emergency	Indicates an emergency call is being received. This message flashes on line two.
TXEMER	Transmit Emergency	Indicates an emergency call has been transmitted on this radio. This message will be flashing on line two.
VOL=31	Volume Level	Indicates the current volume level. The volume level display ranges from OFF (muted) to 40 (loudest).
WHC	Who Has Called	Indicates an individual call has been received, but not responded to. The indicator turns off if the individual call mode is entered, the system is changed, or the radio is turned off and then on again.
UNKNOWN	Unknown ID	Indicates an individual call is being received from an unknown ID.

8.3 ERROR MESSAGES

If either of the Error Messages shown below is displayed, the radio is programmed incorrectly or needs servicing.

DSP ERR or **DIG V**
ERR=XXXX **ERR**
(PowerUp only)

Where **xxxx** is the error code and **DSP ERR** or **DIG V ERR** is the message.







8.4 ALERT TONES

The XG-75 radio provides audible Alert Tones or “beeps” to indicate the various operating conditions (see Table 8-1).

Table 8-1: Alert Tones



NAME	TONE	DESCRIPTION
Call Originate	one short mid-pitched	OK to talk after pressing the push-to-talk button.
Call Queued	one high-pitched	Call queued for processing.
Autokey	one mid-pitched	Queued call received channel assignment.
System Busy	three low-pitched	System busy or unable to complete call.
Call Denied	one low-pitched	Radio is not authorized on the system or group.
Carrier Control Timer	five high-pitched/one long low-pitched	PTT depressed for maximum length of time.
Low Battery	one low-pitched/one short mid-pitched	Low battery.
TX Low Battery Alert	one low-pitched	After PTT - battery too low to transmit.

8.5 SYSTEM SELECTION

- METHOD 1: From the control knob: If system selection is programmed to the System/Group/Channel control knob, select a system by turning the knob to the desired system number position (1-16). The display registers the new system name on line one. The  button can be programmed to provide access to a “2nd bank” of 16 system number positions (17-32).
- METHOD 2: From the keypad: If system selection is programmed as the primary function of  and , select a system by pressing  or  to scroll through the system list. The display registers the new system name on line one.
- METHOD 3: **(System model radios only)** Direct Access: Press  to enter the system select mode. Press the numeric key, which is mapped to the desired system. Press . The radio will move to the selected system.





NOTE

If system selection is programmed to the System/Group/Channel control knob, direct access to systems will not be available. Pressing  or  will scroll through different sets of 16 systems each (banks) if more than 16 systems are programmed into the radio. The systems within each bank are then selectable via the System/Group/Channel control knob as described previously in METHOD 1.







Example:

System: 1 = North
 2 = South
 3 = East
 4 = West

1. Press . (South is the currently selected system.)
2. Press . (Press 4 to select “West” system.)
3. Press . (West is the newly selected system.)

8.6 GROUP/CHANNEL SELECTION

Several methods can be used to select a new group or channel.

- METHOD 1: From the Control knob: If group selection is programmed to the System/Group/Channel control knob, select a group by turning the System/Group/Channel control knob to the desired group number position. The display registers the new group name on line two. If the knob is moved to a position greater than the number of programmed groups, the highest programmed group will remain selected. The  button can be programmed to provide access to a “2nd bank” of 16 group number positions (17-32).
- METHOD 2: From keypad: If group selection is programmed as the primary function of  and , select a group by pressing  or  to scroll through the group list. The display registers the new group name on line two.
- METHOD 3: **(System model radios only)** Direct Access: Press  to enter the group select mode. Press the numeric key mapped to the desired group. Press . The radio will move to the selected group.

8.7 MODIFY SCAN LIST

8.7.1 System Model Radio

1. Press **[3 SCAN OFF]** to toggle scan off and verify is **not** displayed.
2. Select group or channel.
3. Press **[9 DEL FROM LIST]** once to remove group or channel from list.
4. Press **[6 ADD NORMAL]** once to add as a normal group or channel.
5. Press **[6 ADD NORMAL]** twice to add as a Priority 2 group.
6. Press **[6 ADD NORMAL]** three times to add as a Priority 1 group.
7. Press **[3 SCAN ON]** to re-start scanning.

8.7.2 Scan Model Radio

1. Press **[SCN]** to toggle scan off and verify is **not** displayed.
2. Select group or channel.
3. Press **[A/D]** once to remove group or channel from the list.
4. Press **[A/D]** once to add as a normal group or channel.
5. Press **[A/D]** twice to add as a Priority 2 group.
6. Press **[A/D]** three times to add as a Priority 1 group.
7. Press **[SCN]** to re-start scanning.

8.8 MENU

The Menu function accesses features that are not available directly from the keypad. The menu items available and the order of menu items is configurable through programming. Upon radio power up, the menu item that is at the top of the menu list will always be displayed first. Subsequent access to the menu function will return the last menu item that was shown in the display and cursor position.

1. To enter the menu mode, press **[M]**.
2. Upon entering the menu selection mode, menu options will appear in the display (see Figure 8-1).

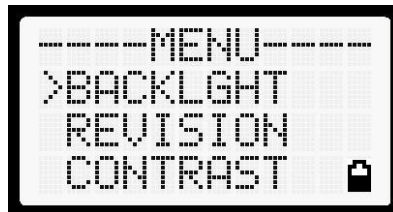

Figure 8-1: Menu Display

3. The radio will continue to receive and transmit normally while in the menu.
4. Use the **[▼]** or **[▲]** keys to scroll through the menu options.
5. Align the **>** with the desired menu option and press **[M]** to select it. The menu item's parameter setting shown in the display can be changed using **[▼]** or **[▲]** to scroll through the list of parameter values.

6. Once the desired setting is reached, press **[M]** to store the value and return to the main display.

For menu items that display radio information, pressing **[v]** or **[^]** will scroll through a list of informational displays. Possible menu items are listed in Table 8-2.

8.8.1 Menu Item Selection Process

An example of the backlight menu item selection process and menu item parameter change is shown in Figure 8-2.

1. Press **[M]**. The menu mode is entered.
2. Press **[v]** or **[^]** until the display shows:

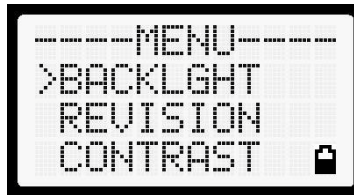

Figure 8-2: Backlight Menu Item Selection Parameter

3. Press **[M]**. The backlight menu item is activated. Line one shows the active menu item and its current parameter setting. Line two shows the currently selected system or group name (see Figure 8-3).

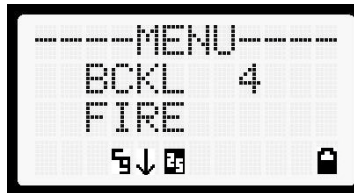

Figure 8-3: Backlight Menu Display

4. The menu item's parameter setting shown in the display can now be changed by using **[v]** or **[^]**.
5. Once the desired setting is reached, press **[M]** to store the value and return the menu option selection level.

For menu items that display radio information pressing **[v]** or **[^]** will scroll through a list of informational displays. An example of information displays is shown in Table 8-2.



NOTE

The TX POWER menu item, when selected, toggles LOW/HIGH power. It does not use **[v]** or **[^]** to scroll nor is an additional press of the **[M]** button required.

Table 8-2: Menu Item Information

FEATURE	DISPLAY	PARAMETER SETTING	COMMENT
Keypad Lock	Menu Item: KEY LOCK	Locked Unlocked	Locks the keypad. To unlock; press and release M then within 1 second press the O button <i>NOTE:</i> This sequence is also a short cut to locking the keypad.
Backlight Adjust	Menu Item: BACKLIGHT	OFF, 1 thru 6	Selects the light level for backlighting.
Contrast Adjust	Menu Item: CONTRAST	1, 2, 3, 4	Selects the display contrast level.
Transmit Power Select	Menu Item: TX POWER	HIGH or LOW	Selects radio output power mode.
Radio Revision Information	Menu Item: REVISION	N/A	Selects the information display to view. <i>Informational display only (see Table 8-3). No user selectable settings.</i>
Toggle Scan On/Off	SCAN	ON/OFF	Toggles Scan operation ON/OFF.
Toggle Private Mode	PRIVATE	ON/OFF	Toggles Private Mode ON/OFF.
Display Current Encryption Key	DISP KEY	N/A	Displays current encryption key. Informational display only. <i>No selectable settings.</i>
Display Current Home Group/Channel	HOME	N/A	Selects Home Group/Channel
Select Desired System	SYS SEL	N/A	Selects a new system.
Add Group/Channel to Scan List	SCAN ADD	N/A	Adds to Scan List.
Delete Group/Channel	SCAN DEL	N/A	Deletes Group or Channel from Scan List.
Add/Delete Scan List	SCAN A/D	N/A	Add or Delete from Scan List.
Select Telephone Numbers From Phone List	PHN CALL	N/A	Trunked Only.
Data Operation	NO DATA	ON/OFF	Trunked Only. Toggles Data Operation ON/OFF.
Select Individual Call from IC List	IND CALL	N/A	
Select Group	GRP SEL	N/A	
Feature Encryption Display	Menu Item: FEATURES	N/A	Indicates current features programmed into the radio as well as certain information required to add features to the radio. <i>Informational display only. No user selectable settings.</i>
System Scan Enable	Menu Item: SYS SCAN	ON/OFF	Toggles System Scan feature ON/OFF.

Table 8-3: Information Display

RADIO ID XXXXXXXX	LID in EDACS/EA. In CONV it has no meaning.
RAM SIZ	RAM Size
FLSH SIZ	Flash Size
RF BAND	Frequency Band
PERS VER	Software Version
DSP DATE	Date DSP code was built.
DSP TIME	Time DSP code was built.
DSP FEAT	The DSP Features supported by the DSP code, in Hexadecimal. Bit mapped (see IPC spec for details): <ul style="list-style-type: none"> • 0x0001 – Conventional • 0x0002 – EDACS • 0x0010 – AMPF • 0x0020 – undefined
DSP VER	DSP Software Version
FLSH VER	FLASH Software
HARRIS (C) 2011	Copyright
PERSNLTY	Personality Name
BLD DATE	Date host (ARM) code was built.
BLD TIME	Time host (ARM) code was built.

8.9 BACKLIGHT ADJUST

1. Press **[M]** to access the menu.
2. Press **[v]** or **[^]** to scroll through menu until “BACKLGHT” appears.
3. Press **[M]** to select the backlight menu.
4. Press **[v]** or **[^]** to scroll through available settings off, 1 through 6.
5. Press **[M]** to select new backlight setting.

8.10 CONTRAST ADJUST



1. Press **[M]** to access the menu.
2. Press **[v]** or **[^]** to scroll through menu until “CONTRAST” appears.
3. Press **[M]** to select Contrast menu.
4. Press **[v]** or **[^]** to adjust contrast setting from 1 - 4.
5. Press **[M]** to select new contrast setting.

8.11 DECLARE AN EMERGENCY

1. Press and hold the red Emergency/Home button. The length of time to hold the button is programmable; check with the system administrator.
2. ***TXEMER*** will flash in the display, and will be displayed. After 2-3 seconds the transmit icon will turn off.





3. ***TXEMER*** continues to flash until the emergency is cleared. See Section 8.17 for additional emergency operation.
4. Press the PTT and  will reappear.
5. Release PTT when the transmission is complete.

8.12 LOCKING/UNLOCKING KEYPAD



1. Press  button.
2. Within 1 second, press the  button on the side of the radio.

8.13 HIGH/LOW POWER ADJUSTMENT

Transmit power adjustment is possible if enabled through programming. Within conventional systems, transmit power is adjustable on a per channel basis. Within EDACS trunking systems, transmit power is adjustable on a per system basis.

1. Press .
2. Using the  or  keys, select “TX POWER.”.
3. Press  again to toggle between High and Low power.
4. “POWER = HIGH” or “POWER = LOW” will appear momentarily on the top line of the display.

8.14 ENCRYPTION

The XG-75 portable radio supports AES and DES encryption. When operating on a group or channel programmed for encryption, all transmissions are encrypted and the radio receives clear and encrypted signals. The  icon is displayed when encryption is enabled. If enabled via programming, the encryption can be enabled or disabled by pressing the  key and selecting the **PRIVATE** menu option. If not enabled, the radio displays **FRCD PUT** when you try to disable encryption.

8.14.1 Displaying the Currently Used Cryptographic Key Number

To display the Currently Used Cryptographic Key Number for either the system encryption key (for special call such as individual, phone, all, agency or fleet) or the group/channel key (for group or conventional calls), perform the following procedure:





1. Press the .
2. Use the  or  button to select **DISP KEY**.
3. Use the  or  button to toggle between displaying the system key (Figure 8-4) or the group/channel key (Figure 8-5).



Figure 8-4: System Encryption Key Display



Figure 8-5: Group/Channel Encryption Key Display

8.14.2 Key Zero

All cryptographic keys can be zeroed (erased from radio memory) by pressing the button and while still pressing this button, press and hold the button. Press both buttons for 2 seconds. A series of beeps will begin at the start of the 2 second period and then switch to a solid tone after the keys have been zeroed. The display will indicate **KEY ZERO**.

If the cryptographic key(s) are zeroed, one or more keys must be transferred from the Keyloader into the radio before private communications may continue.

8.14.3 Receiving an Encrypted Call

When receiving, the radio automatically switches between clear or private operation. If the transmission being received is an encrypted transmission, it will be decrypted, the icon will be displayed, the receiver will unscquelch, and the message will be heard in the speaker. For this to occur, the selected group or channel must be programmed for private operation and the correct cryptographic key must be loaded into the radio.

8.14.4 Transmitting an Encrypted Call

1. Select the desired group or channel.
2. Place the radio in Private Mode by pressing key, then select **PRIVATE** from the menu. On a System radio, the key can be used to toggle the Private Mode on/off. When Private Mode is enabled, the icon is displayed.
3. If the last state of the radio was Private Mode, the Private Mode will be enabled on power up. Also, the Private Mode will be enabled if forced operation has been programmed in the radio.

If a group or channel is not programmed for Private Mode operation, **PUT DIS** will be displayed if an attempt is made to enable private transmit mode. It is not possible to operate on this group/channel in Private Mode.







If the radio does not have the correct encryption key loaded, **NOKY** will be displayed and the call will not be transmitted.

4. Continue with standard transmission procedures. A Private Mode access tone will be heard when the PTT button is pressed.

8.15 SCANNING TRUNKED GROUPS













Groups that have been previously added to the scan list on a per system basis may be scanned. Each system's group scan list is retained in memory when the radio is powered off or when the battery pack is removed.

8.15.1 Turning Scan On and Off

1. Toggle Scan operation on by pressing  (Scan model) or  (System model).  icon rotates clockwise to indicate radio is scanning.
2. Toggle Scan operation off by again pressing  (Scan model) or  (System model).  will disappear.
 1. If the radio scans to a group other than the selected group then receives a call on the selected group, the radio will switch to the selected group. However, if the “scanned-to” group is programmed at a higher priority the radio will remain on the “scanned-to” group.
 2. The radio will continue scanning if a new group is selected when scan is on.
3. Pressing the PTT button when scan is on will cause the radio to transmit on the displayed group or to the currently selected group (depending on programming).

8.15.2 Adding Groups to a Scan List

Scan Model Radio

1. Scan must be off to add/delete groups to/from the scan list. If the Scan icon  is on, press the  key to turn Scan off.
2. Select the desired group using the System/Group/Channel control knob and/or the  or  keys. If the selected group is currently on the list, pressing  will display  on line three.
3. If the scan list status icon is blank, the group can be added to the scan list by pressing the  key.  will be displayed on line three.
4. Press the  key a second time to set the group to Priority 2. A  is displayed on line three.
5. Press  a third time to set the group to Priority 1. A  is displayed on line three. The priority level section sequence only advances the group to the next high priority level and stops at priority level 1. To select a lower priority level, the group must be deleted from the scan list and then added back to the scan list. Each new group added to the scan list starts at the lowest priority. If the Priority 1 and Priority 2 groups are already set and a new group is assigned as Priority 1 or Priority 2, the previously assigned group will change to non-priority scanning. One of the following messages may be momentarily displayed.

SCAN DIS The radio is not programmed to scan.

FIXED P1 A Priority 1 group has been pre-programmed into the radio. A new Priority 1 group cannot be selected.

FIXD LST A fixed scan list has been pre-programmed into the radio. It is not possible to change the list without reprogramming the radio.



NOTE

To quickly view multiple group scan status, press  then rotate the group knob. Each group status will appear on the display.

System Model Radio

1. With scan operation turned off, select the desired group to add to the selected trunked system group scan list.

2. Press **[6 ADD]**. The current priority status of the group will be displayed in column 10 of line three for a time-out period. If the group is not part of the scan list, the status will be blank.
3. While the status is displayed, press **[6 ADD]** to add the group to the scan list. The **|||** icon is displayed on line three.
4. Press **[6 ADD]** a second time to set the group to Priority 2. The **||** icon is displayed on line three.
5. Press **[6 ADD]** a third time to set the group to Priority 1. The **|** icon is displayed on line three. The priority level selection sequence only advances the group to next higher priority level and stops at priority level 1. To select a lower priority level, the group must be deleted from the scan list and then added back to the scan list. Each new group added to the scan list starts at the lowest priority. If the Priority 1 and Priority 2 groups are already set and a new group is assigned as Priority 1 or Priority 2, the previously assigned group will change to non-priority scanning. One of the following messages may be momentarily displayed.

SCAN DIS The radio is not programmed to scan.

FIXED P1 A Priority 1 group has been pre-programmed into the radio. A new Priority 1 group cannot be selected.

FIXD LST A fixed scan list has been pre-programmed into the radio. It is not possible to change the list without reprogramming the radio.



NOTE

To quickly view multiple group scan status, press either **[6 ADD]** or the **[9 DEL]** key. Then rotate the group knob. Each group status will appear on the display.

8.15.3 Deleting Groups from a Scan List

Scan Model Radio

1. With scan operation turned off, select the desired group to delete from the selected trunked system group scan list.
2. Press **[A/D]**. The current status of the group is displayed for a time-out period.
3. While the current status is displayed, press **[A/D]** until the group from the scan list is "**blank**." The sequence is "**blank**," **|||**, **||**, **|**, "**blank**." Any group that is not in a trunked system group scan list will show a "**blank**" for the time-out period when it is the selected channel.

System Model Radio

1. With scan operation turned off, select the desired group to delete from the selected trunked system's group scan list.
2. Press **[9 DEL]**. The current status of the group is displayed for a time-out period.
3. While the status is displayed, press **[9 DEL]** to delete the group from the scan list. **|||**, **||**, or **|** turns off. Any group that is not in a trunked system group scan list will show a "**blank**" for the time out period when it is the selected channel.

8.15.4 Nuisance Delete

A group can also be deleted from the scan list, if it is not the currently selected group, by pressing the **[A/D]** key (Scan model) or the **[9 DEL]** key (System model) during scan operation while the radio is displaying the unwanted group. The group will be deleted from the system's group scan list in the same manner as if

done using the steps above. Deletions done in this manner will not remain deleted if the radio is powered off and then powered on.

8.16 SCANNING TRUNKED SYSTEMS

The radio can be programmed using Radio Personality Manager (RPM) with the following System Scan features. Then these features are automatically enabled when the radio is powered on. A key or menu option is also defined to allow the System Scan features to be toggled during radio operation. The System Scan state will be maintained through system changes but will default to on when the radio is powered on.

Enable/Disable via Menu Selection

Press **[M]** and then use the **[▼]** or **[▲]** buttons to scroll through the selections until **SYS SCAN** is displayed. Then press **[M]** to toggle the System Scan state. The **SYSC ON** or **SYSC OFF** display message is displayed for two seconds to show the new state.

Enable/Disable via Pre-Programmed Keypad Key

Press the key pre-programmed to toggle System Scan and the **SYSC ON** or **SYSC OFF** display message is displayed for two seconds to show the new state.

8.16.1 Wide Area System Scanning

The XG-75 series radio can be pre-programmed through RPM for Wide Area System Scan operation for roaming across mobile systems. EDACS radio systems manage the radios assigned to the system via a control channel (CC). Upon the loss of the currently selected system's control channel, radios can be programmed to automatically scan the control channels of other systems. If a new control channel is found, the radio will switch to the new system and sound an alert tone.

8.16.2 Priority System Scan

The radio can also be pre-programmed for Priority System Scan. The priority system is the desired or preferred system. While receiving the control channel of the selected system, the radio will periodically leave the selected system and search for the control channel of the priority system. This is done at a pre-programmed rate defined by the value in the Priority Scan Time control, unless the ProScan™ algorithm is enabled, as explained in the following sections. This priority scan timer is reset each time the PTT button is pressed or when the call is received. If the priority system control channel is found, or meets the predefined criteria (ProScan), the radio will automatically switch to the priority system.

8.16.2.1 Enabling the Wide Area System Scan Function

If the radio cannot find the control channel of the selected system and begins to wide area system scan, the radio will only scan for the priority system control channel if the priority system is in the wide area scan list.

8.16.2.2 When ProScan is Enabled

The radio monitors the priority system and will switch to the priority system if the pre-programmed criteria ProScan options are met. If ProScan is enabled, the rate at which the radio will scan for the priority system is defined by the System Sample Time control, set in RPM (refer to RPM On-Line Help). See Section 8.16.3 for more information on ProScan.

8.16.3 ProScan

The radio may be programmed for ProScan system scan operation for multi-site applications. ProScan is a multi-site, system-scanning algorithm. ProScan provides the radio with the ability to select a new system for the radio to communicate on, when the selected system drops below a predefined level. This algorithm enables each radio to analyze the signal quality of its current control channel and compare it with the signal quality of the control channel for each site in its adjacent scan list. The signal quality metric used for the ProScan algorithm is based on a combination of both Received Signal Strength Indicator (RSSI) and Control Channel Verification (CCV) measurements. When the selected system degrades to a pre-programmed level, the radio will begin to look for a better control channel. Once a control channel that exceeds the pre-programmed parameters is found, the radio will change to the new system and emit a tone (if enabled through programming). If the control channel is completely lost, the radio will enter Wide Area System scanning and search the programmed adjacent systems until a suitable control channel is found.

8.17 EMERGENCY OPERATION



The radio's ability to declare an emergency, clear an emergency, remain locked on an emergency system and group, and the emergency audio and display freeze can each be enabled or disabled through programming. When an emergency is declared, scanning will stop and restarts only after the emergency has been cleared.



8.17.1 Receiving an Emergency Call

When receiving an Emergency Call on the selected group and system, an alert beep is heard and  is displayed. The message ***RXEMER*** flashes in the display on line two until the emergency condition is cleared.

8.17.2 Declaring an Emergency Call

Perform the following steps to send an emergency call to a selected system and group (or on an optionally pre-programmed group).

1. Press and hold the red EMERGENCY button that is on top of the radio in front of the antenna for approximately one second (this time is programmable and therefore could be longer or shorter; check with the system administrator). The radio will transmit an emergency call request with the radio ID until an emergency channel assignment is received.
2. When the working channel assignment is received, the radio sounds a single beep indicating the radio has auto keyed (see Table 8-1) and is ready for voice transmission. ***TXEMER*** flashes on line two in the display until the emergency is cleared.
3. Press PTT and speak into the microphone in a normal voice.  and  momentarily turn on.
4. Release PTT when the transmission is complete.

To clear the emergency, first press and hold the  button. While continuing to hold the  button, press the EMERGENCY button. The radio must be programmed to clear emergencies.)

8.18 INDIVIDUAL CALLS

8.18.1 Receiving and Responding to an Individual Call

When the radio receives an individual call (a call directed only to the user's radio), it un-mutes on the assigned working channel and displays . The first line on the display shows the logical ID number of

the unit sending the message, or the associated name if the ID number is found in the individual call list. The radio can be programmed to ring when an individual call is received. If enabled, the ring begins five seconds after the caller un-keys and will continue until the PTT button, the button or the individual call mode is entered.



NOTE

The volume of the ring is adjustable through the volume control levels.

If a response is made by pressing the PTT to the call prior to the programmed call-back time-out, the call will automatically be directed to the originating unit. If a response is not made before the call-back time-out, the radio will return to normal receive display, and ***WHC*** will appear on the first line of the LCD.

To respond after the call-back time-out, press the key. The radio's display will show the callers ID on the first line and **WHCI=1** on the second line. Pressing the PTT button at this point will initiate an individual call back to the original caller.

The radio stores the IDs of the last 10 callers in the Calls Received List as shown. Individual calls are stored in the top half of the list (1-10) and Group calls are stored in the bottom half of the list (1-10). The most recent call is stored in position 1, the second most recent call is stored in position 2, etc.

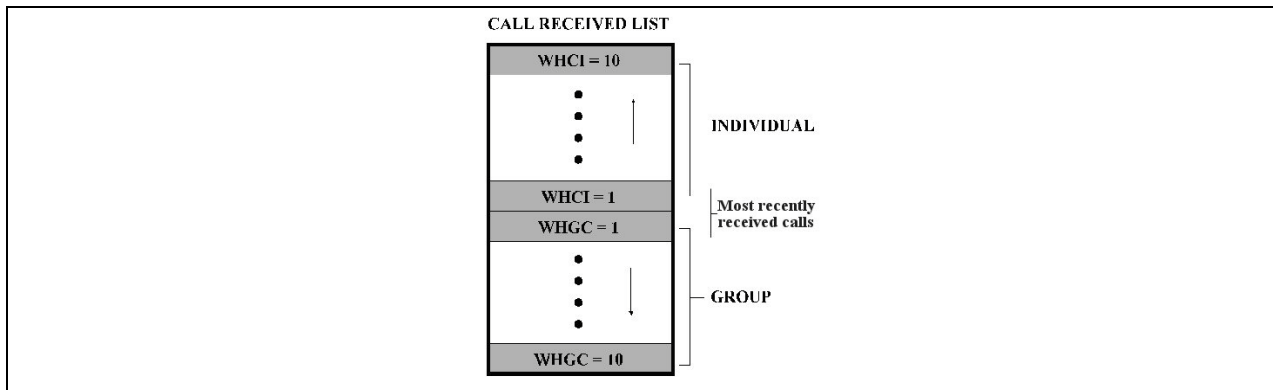

Figure 8-6: Calls Received Lists

To access the Calls Received List, press the key twice. Use the or buttons to scroll through the list. Pressing the key will display the time elapsed since the call was received. After pressing the display will appear similar to Figure 8-7.



Figure 8-7: WHC Individual Call Display

Pressing the PTT will initiate an individual call to the displayed logical ID. Powering the radio off and on will clear this list.

8.18.2 Sending an Individual Call

8.18.2.1 Pre-Stored Individual Calls

The following procedures describe how to initiate and complete a Pre-Stored Individual Call.

System Model Radio

1. To select a pre-stored individual phone number, enter the individual call mode using the **[#IND]** key. **[#]** is displayed. Then scroll through the list of stored numbers using the **[▼]** or **[▲]** keys.
2. Press the PTT button; when the radio is clear to transmit, **[PTT]** turns on, **[#]** turns off, and the channel access tone sounds. Line one shows the called individual's name if found in the list of stored individuals or **LID** followed by the logical ID number of the unit being called. The message ***INDU*** displays on line two.

Scan Model Radio

1. To select a pre-stored individual number, enter the menu mode by pressing the **[M]** key. Scroll through the mode list using the **[▼]** or **[▲]** buttons.
2. Press **[M]**. **[#]** is displayed. Scroll through the list of stored phone numbers using the **[▼]** or **[▲]** buttons until the desired number is displayed. Press **[M]**.
3. Press the PTT button; when the radio is clear to transmit **[PTT]** turns on, **[#]** turns off, and the channel access tone sounds. Line one shows the called individual's name or LID. The message ***INDU*** displays on line two.

8.18.2.2 Direct Dial Individual Calls (System Model Only)

1. The following procedure describes how to initiate and complete a Direct Dial Individual Call.
2. The individual call ID is not stored in the pre-stored list of call IDs but the individual unit ID is known, it can be entered directly from the keypad.
3. Press and hold the PTT button to transmit. **[PTT]** will turn on, **[#]** will turn off, and the channel access tone will sound. Line one shows the called individual's ID followed by the logical ID number of the unit being called. The message ***INDU*** displays on line two. Proceed talking into the microphone.

8.18.3 Call Storage Lists

There are two lists available for call storage in the XG-75 series radios, the calls received list (1 - 10) and the personality list (1 - 99 as defined by the user). When the individual call mode is entered by pressing **[#IND]**, the calls received list is available. The user can toggle to the personality list by selecting any index other than 0 or toggle between the two lists by pressing the **[#IND]** key. If wrap is enabled, the calls received list wraps on itself and not into the other list.

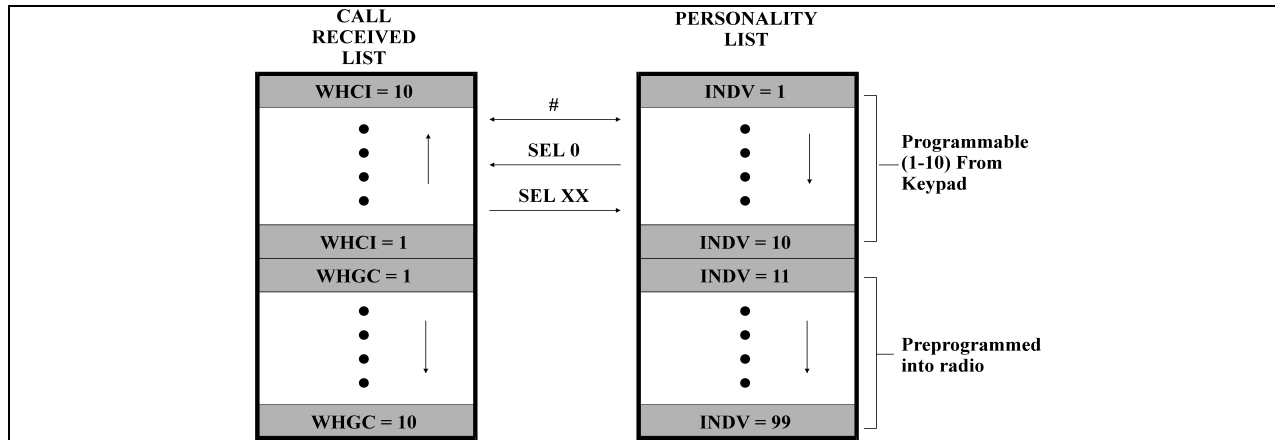

Figure 8-8: Calls Received and Personality Lists

The saved call list shows all ten storage locations. If no calls have been received, the saved call list will be empty and the pre-stored list will be available upon entering the individual call mode.

When in the saved call list, pressing the **M** key toggles the time stamp on and off. The time stamp indicates how long ago the call was received. When in the pre-stored list pressing the **M** key toggles the Logical Identification (LID) on and off.

8.19 TELEPHONE INTERCONNECT CALLS

8.19.1 Receiving a Telephone Interconnect Call

When the radio receives a telephone interconnect call (a call directed only to the user's radio), it un-mutes on the assigned working channel and displays **T**. The first line displays ***PHONE***. The second line displays ***INDV***. Proceed with the call. Press the PTT to talk, release the PTT to listen.

8.19.2 Sending a Telephone Interconnect Call

8.19.2.1 Pre-Stored Number

Use the following procedures to initiate and complete a Telephone Interconnect call.

1. **System Model:** To select a previously stored phone number, press the ***PHN** key. Use the **▼** or **▲** buttons to scroll through the list of stored numbers.

Scan Model: To select a previously stored phone number, press the **M** key. Use the **▼** or **▲** buttons to select the menu option **PHN CALL**. Press the **M** key again then use the **▼** or **▲** buttons to scroll through the list of pre-stored numbers.

2. Press and release the PTT button. When the radio is clear to transmit, **↑** turns on, **↓** turns off, and the channel access tone sounds. Line one shows the accompanying name selected from the list of stored numbers. The message ***PHONE*** appears on line two of the display. The radio then automatically transmits the programmed number stored in the special call queue.
3. A telephone ring will be heard from the speaker. When someone answers the phone, press the PTT button and speak into the microphone. Release the PTT button to listen to the callee. Unsuccessful interconnect signaling returns the radio to the normal receive mode and the number remains displayed until the special call is cleared or the time-out expires or another group or system is selected. Terminate a call by pressing the **⊙** button.



NOTE

In half-duplex mode, only one person may talk at a time. The radio PTT button needs to be pressed in order to communicate to the individual called and released for the individual called to be heard.

8.19.2.2 Direct Dialing of Phone Calls (System Model Only)

1. If the phone number is not stored in the pre-stored list of phone numbers, but the phone number is known, it can be entered directly from the keypad. Start by pressing the  key, then enter the required number from the keypad. Press and release the PTT button.



NOTE

The last number directly entered can be recalled by first pressing  then pressing the PTT button.

2. A telephone ring can be heard from the speaker. When someone answers the phone, press and hold the PTT button and speak into the microphone. Release the PTT button to listen to the individual called. Unsuccessful interconnect signaling returns the radio to the normal receive mode and the number remains displayed until the special call is cleared or the time-out expires or another group or system is selected.
3. To terminate the call, momentarily press the  button.





8.19.3 Dual-Tone Multi-Frequency: Overdial



Once the radio has established a connection to the public telephone system, it may be necessary to “overdial” more digits to access banking services, answering machines, credit card calls, or other types of systems that require Dual-Tone Multi-Frequency (DTMF) access digits.

Overdial operation can also be used to initiate a telephone interconnect call via DTMF signaling if a dial tone has already been accessed on the system. This method makes a telephone interconnect call while operating in the conventional mode but will also function in trunked mode if a dial tone is directly accessible.

Telephone numbers and other number sequences for overdialing can be stored in the phone list when programming the radio. These numbers are accessed by pressing the  key, then following the selection mode rules. Perform the following procedures to access and dial these stored numbers.

Scan Model Radio

1. Follow the procedure in Section 8.19.2 to establish a connection to the telephone system or consult the system administrator for the procedure to access a dial tone on the trunked or conventional system.
2. Enter selection mode first to enable entry of overdial numbers by pressing the  button.
3. Follow the selection mode rules to call up a stored number from the phone list: Use the  or  buttons to scroll through the list of stored numbers.  is displayed. Press the PTT to send the overdial sequence once. If the number needs to be transmitted again it must be selected or entered again (this prevents unwanted numbers from being sent the next time the PTT button is pressed during the call).

Overdial select/entry mode remains active until the call is dropped, cleared, or  is pressed. The overdial select/entry mode can be re-entered if the call is still active by pressing .

System Model Radio

1. Follow the procedure in Section 8.19.2 to establish a connection to the telephone system or consult the system administrator for the procedure to access a dial tone on the trunked or conventional system.

2. Overdial numbers are transmitted using one of the following methods:

METHOD 1: 1. Enter the overdial selection mode by pressing the **[*PIN]** button.

2. Use the **[▼]** or **[▲]** buttons to scroll through the list of stored numbers. **[L]** is displayed. Press the PTT to send the overdial sequence once. If the number needs to be transmitted again it must be selected or entered again (this prevents unwanted numbers from being sent the next time the PTT button is pressed during the call).

Overdial select/entry mode remains active until the call is dropped, cleared, or **[M]** is pressed. The overdial select/entry mode can be re-entered if the call is still active by pressing **[M]**.

METHOD 2: **(System model radios only)**

1. Enter the overdial selection mode by pressing the **[*PIN]** button.

2. Press and hold the PTT button while entering the overdial number sequence from the keypad. This method sends DTMF tones during individual, telephone interconnect, trunked group, or conventional channel calls. Press the PTT to send the overdial sequence once. If the number needs to be transmitted again it must be selected or entered again (this prevents unwanted numbers from being sent the next time the PTT button is pressed during the call). *Note: Anytime the PTT button is pressed and held, the keypad is enabled for DTMF entry.*

Overdial select/entry mode remains active until the call is dropped, cleared, or **[M]** is pressed. The overdial select/entry mode can be re-entered if the call is still active by pressing **[M]**.

This overdial select/entry mode remains active until dropped, cleared, or **[M]** is pressed. The overdial select/entry mode can be re-entered if the call is still active by pressing the **[*PIN]** button.

8.20 PRE-STORING INDIVIDUAL AND TELEPHONE INTERCONNECT CALLS FROM THE KEYPAD

Individual Call ID numbers, telephone numbers, and other number sequences for over dialing are stored in the special calls lists when programming the radio. The first ten entry locations of these lists can be changed by the radio operator. The keypad is used when adding, changing, and storing numbers in these entry locations.

Use the following procedure to store a number in one of the first ten entries of a special call list:

1. Press the **[#IND]** or **[*PIN]** button to enter the individual call list or the phone call list. **[L]** is displayed.
2. Scroll through the list using the **[▼]** or **[▲]** keys until one of the first ten entries is reached. **NO ENTRY** is displayed if the location is empty.
3. Enter the desired number. If necessary, a pause can be entered by pressing and holding 0-9, **[#IND]**, or **[*PIN]** until an underscore appears in the display (telephone interconnect only). The individual call list entries will accept up to 5 digits. The phone call list entries accept a combination of up to 31 digits and pauses.

4. Press and hold the **[M]** key until the display changes indicating that the number has been stored.

Repeat steps 1-4 to store additional numbers, to change numbers already stored, or to change the storage location of a number.

8.21 STATUS/MESSAGE OPERATION

The **Status** and **Message** operations allow for the transmission of a *pre-programmed status* or a *pre-programmed message* to an EDACS or P25 site. Each Status and Message is assigned an ID then cross-referenced with the representative status condition (“Off Duty,” for example) or a message (“Call home”). In addition, Status conditions can also be associated with a programmable Menu entry (required for second method of transmitting a Status condition).

8.21.1 Status Operation

System Model Radio

One of two methods can be used to transmit a status condition.

- METHOD 1:
1. Press the **[M]** key, then use the **[▼]** or **[▲]** buttons to scroll to the pre-programmed status condition. STATUS and 0 through 9 pre-programmed status selections are available from the menu.
 2. If STATUS is selected, you need to enter the number of the status condition you intend to transmit. If no status has been programmed for the selected number key, the radio will display **NO ENTRY**. A valid selection will display the status for a pre-programmed time.

After the time-out expires or the **[M]** key has been pressed (the **[M]** key will override the time-out period), the status is selected and will be transmitted to the site or stored in the radio memory where it can be polled by the site at a future time.

- METHOD 2:
1. Press the **[7 PPS]** key.
 2. Press the corresponding pre-programmed 0 through 9 status condition key. If no status has been programmed for the selected number key, the radio will display **NO ENTRY**. A valid selection will permit the status condition to appear in the top line of the display and the status ID to appear in the second line of the display for a pre-programmed time.

After the time-out expires or the **[M]** key has been pressed (the **[M]** key will override the time-out period), the status is selected and will be transmitted to the site or stored in the radio memory where it can be polled by the site at a future time.

View the currently selected status after it has been transmitted by pressing the **[M]** key and then the **[M]** key and then the **[⊙]** button prior to the time-out period. If the status was not sent successfully to the site, the text associated with the status condition will flash in the display.

The status selection can be changed by pressing a different status key 0 through 9, or the status operation can be cancelled by pressing **[⊙]**. Both operations must be carried out prior to the time-out period.

8.21.2 Message Operation

The following method can be used to transmit a Message using the Message Operation.

1. Press the **[8 MSG]** key.

2. Press the corresponding pre-programmed 0 through 9 pre-programmed “message” key. If no message has been programmed for the selected number key, the radio will display **NO ENTRY**. A valid selection will permit the message to appear in the top line of the display and the message ID to appear in the second line of the display for a pre-programmed time.

The message selection can be changed by pressing a different message key 0 through 9, or the message operation can be cancelled by pressing \odot . Both operations must be carried out prior to the pre-programmed time-out period.

8.22 DYNAMIC REGROUP OPERATION (EDACS)

Dynamic Regroup Operation permits multiple talk groups (up to eight) to be added to a radio via the system manager. The radio must be pre-programmed to respond to regrouping. Dynamic regrouping will not be activated in a radio until the system manager sends an activation message. Each radio that receives and acknowledges the regrouping instructions is successfully regrouped.

Pressing and holding the \odot button for 2.5 seconds toggles the user into and out of the dynamic regroup groupset. A double beep will sound for entry or exit. The display will indicate **REGRP_0x** where "x" is a digit of 1 to 8 indicating the group (when dynamic regroup has been enabled by the user). If the radio is in dynamic regroup and the user selects a group that has not been regrouped, the display will show **NO ENTRY**. The radio will be prevented from transmitting and receiving calls in this condition except for scanned groups.

After the time-out expires or the $\square M$ key has been pressed (the $\square M$ key will override the time-out period), the status is selected and will be transmitted to the site or stored in the radio memory where it can be polled by the site at a future time.

8.22.1 Emergency Operation

If the pre-programmed groupset on the currently selected system contains an EMER/HOME group and the radio is in dynamic regroup, the radio will declare the emergency on the currently selected dynamic group.

8.23 MACRO KEY OPERATION

Macro key operation permits the user to accomplish a series of keystrokes with a single "macro" keystroke. Each Macro Key is capable of executing up to twenty (20) keystrokes, to any push button input (i.e., keypad keys, option buttons, etc.). Each macro key can be pre-programmed to activate when pressed or when released. A macro key can also be pre-programmed to change the key stroke sequence the next time the macro key is activated.

For detailed operation and assignment of macro keys, contact your communications supervisor or administrator.

8.24 DATA COMMUNICATIONS

The XG-75 series portable radios, when operating in trunked configuration, permit both voice and data calls to be transmitted and received. The radio can handle only one type of call at a time; however, either data or voice is selected transparently by the operator through normal usage of the radio. Data communications is not supported in conventional mode.

The radios can be connected to a Mobile Data Terminal (MDT) or to a host computer. Any RS-232 compatible device that supports the Radio Data Interface (RDI) protocol (Version 1.91 or greater) may be connected to the radio. Support for MDTs or host computers is a programmable option per radio.

Additionally, radios may also be programmed for data only operation (no voice calls transmitted or received).

8.24.1 Displays

The following will be displayed during the various states of data mode of operation:

- TX DATA** Appears on top line of display when the radio is transmitting a data call.
- RX DATA** Appears on top line of display when the radio is receiving a data call.
- DATA OFF** Appears on top line of display when the radio is in the data disabled state.
- DATA ON** Appears for two seconds on top line of display when the radio is toggled to the data enabled state.

8.24.2 Data Off Operation

The radio can be placed in the data disabled state by any of the following methods. When the data state is disabled, **DATA OFF** appears on the top line of the display.

- Declaring an emergency (not to be used unless an actual emergency condition exists). Alert tone will sound.
- Pressing button **○** (if pre-programmed as “no data” key). Alert tone will sound.
- Pressing the pre-programmed “no data” (ND) key. Refer to previous bullet.

8.24.3 Data On Operation

The data state is enabled by one of the following (depending on how it was disabled). **DATA ON** will appear on the top line in the display for two seconds then the display will return to normal.

- Pressing the pre-programmed “no data” (ND) key toggles data state on or off.
- Clearing an emergency. *This is valid only if the emergency caused “DATA OFF” operation.*

8.24.4 Exiting Data Calls

Under normal conditions, the radio enters the scan lockout mode and returns to the control channel after completion of a data call (transmit or receive). If, during a data call, one of the following operations occurs, the data call is immediately terminated and the radio performs the desired function:

- If the PTT is activated.
- If an Emergency is declared by pressing the pre-programmed emergency button.
- If a group or system is changed.

8.24.5 Scan Lockout Mode

Following the transmission or reception of a data call, if scan is enabled, scanning will stop temporarily. There are two independent pre-programmed times associated with this mode; one after a received data call and one after a transmitted data call. During this time the scan indicator will flash to indicate that scan is enabled but temporarily suspended. This condition typically returns to normal scan operation when the pre-programmed time expires; however, the following operations and conditions will terminate the scan lockout mode before the timeout has expired.

- Press the **Ⓞ** button.

- Press the PTT.
- Change a group or system.
- Enter Telephone Interconnect mode.
- Enter Individual call mode.
- Receive a new emergency assignment.
- Declare or clear an emergency.
- Receive an individual or phone call.
- Receive an Agency, Fleet, or System All Call.
- Press **[SCN]** (Scan model) or **[3STEP]** (System model) to toggle Scan on or off.

8.24.6 Data Lockout Mode

During the voice call scan hang time (pre-programmed) the radio does not receive data calls.

8.25 SELECTIVE SIGNALING (CONVENTIONAL)

Selective signaling controls the muting and unmuting of the receive audio. This allows a user or dispatcher to selectively call an individual radio or group of radios. The XG-75 portable radios support selective signaling in Type 99 decode format.

8.25.1 Type 99 Operation

Type 99 is a conventional in-band, two-tone sequential signaling method. This conventional signaling protocol controls the muting and unmuting of a radio. Type 99 encoded base stations, mobiles, or portables can selectively call individual units or groups of units in a conventional system. Type 99 is used in paging operations providing a dispatcher with the ability to selectively call a radio or a group of radios. If Type 99 is enabled in the radio personality, the radio can decode Individual, Group, and Supergroup Type 99 calls.

In a selective signaling environment, the XG-75 portable radios operate in one of two states, Monitor mode or Selective Call mode.

- In Monitor mode, Type 99 “OFF,” the decoder is disabled and all calls are heard by the user.
- In Selective Call mode, Type 99 “ON,” the decoder is enabled and only calls intended for the user will be heard.

8.25.2 Type 99 with or without Channel Guard

Selective signaling operates with or without Channel Guard. If Channel Guard is enabled, the radio can be programmed with an "And" or an "Or" option, determined by programming with T99 Mute Control.

- If the "And" option is programmed, T99 calls require the correct selective signaling (T99 tone sequence) **AND** the correct Channel Guard tones are heard by the user.
- If the "Or" option is programmed, calls with the correct Channel Guard tones **OR** calls with the correct T99 tone sequence and Channel Guard tones are heard by the user.

A radio operating in Selective Call mode that receives a selective call switches to the Monitor mode (after decoding the T99 call) and the **TX/RX LED** flashes green. The **TX/RX LED** indicates whether the channel has a carrier signal.

8.25.3 Resetting Type 99 after a Call

After decoding a Type 99 call, the radio operates in Monitor mode and all traffic on the channel is audible. If the channel has Channel Guard, only the traffic with the radio's Channel Guard tone will be heard.

To reset Type 99 operation, use one of the following methods:

- Press the ☉ button.
- Press the ○ button, if enabled through programming to toggle Type 99 on/off.
- Allow the "Auto-Reset" timer, if enabled through programming, to reset the Type 99 decoder.

8.25.4 Type 99 Disable after PTT

The radio may be programmed with the Type 99 Disable after PTT feature, which automatically disables the Type 99 decoder after a transmission.

Use one of the methods outlined in the Section 8.25.3 to reset Type 99 operation.

9 PREVENTIVE MAINTENANCE

9.1 IMMERSIBLE PREVENTIVE MAINTENANCE

XG-75 radios labelled “immersible” (see Figure 9-1) require periodic testing using specialized equipment to verify the radio’s watertight integrity.

To recertify the watertight integrity of the XG-75 portable radio, the radio must be inspected by a service center authorized and certified by Harris to perform the necessary tests to verify the watertight integrity.

The Harris Service Network includes company-owned service facilities as well as the capabilities of service partners located throughout the world. We have over 250 Authorized Service Centers (ASC) qualified to perform warranty repairs, installation and maintenance services. For a list of ASCs, contact our Customer Care Center.

Preventive Maintenance for Immersion-Rated Radios



XG-75 radios with Immersion Option MAEV-PKGMR must be serviced by a service center authorized and certified by Harris to perform the necessary tests to verify watertight integrity. As part of a thorough preventive maintenance plan, Harris recommends Immersion-Rated XG-75 radios are, at a minimum, tested and re-certified on an annual basis. Harris further recommends that the radios be tested on or close to the anniversary of the ship date printed on the Model Number label on the back of the radio (see Figure 9-1).

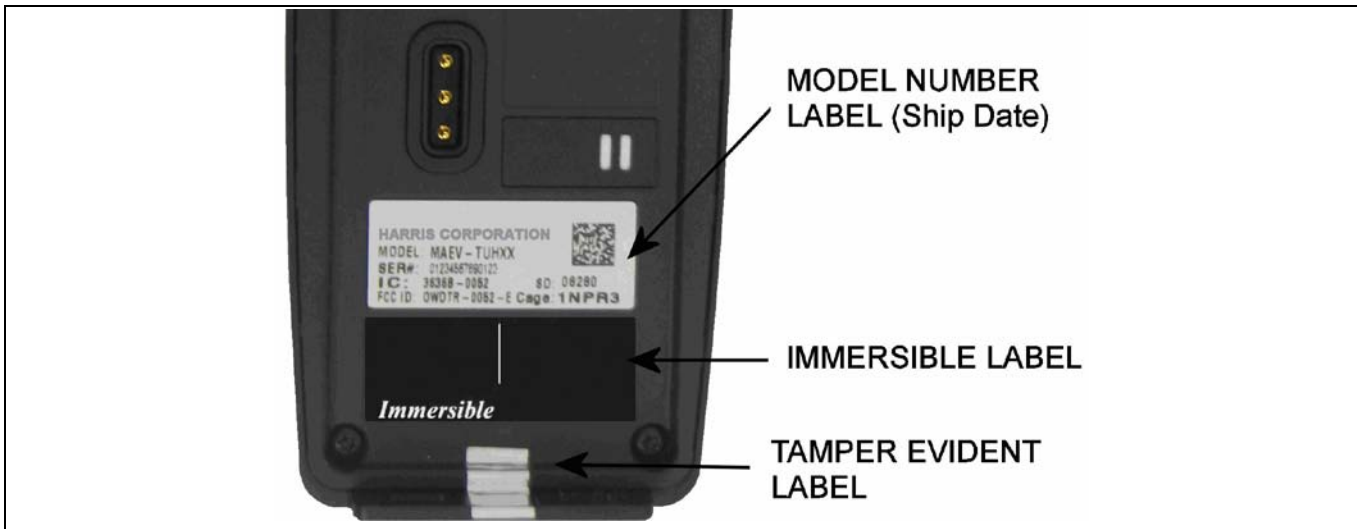



Figure 9-1: Labels

9.2 BASIC TROUBLESHOOTING

Use Table 9-1 as a troubleshooting guide if the radio is not functioning properly. If additional assistance is required, contact a qualified service technician or call Harris at 1-800-528-7711.

Table 9-1: Troubleshooting

SYMPTOM	POSSIBLE CAUSE	POSSIBLE SOLUTION
Radio will not turn on.	Low battery charge.	Change the battery pack to a fully charged pack.
No Audio.	Speaker volume is muted.	Increase the volume level.
Poor Audio.	User is in a poor coverage area or not on the network.	Move to a better coverage area.
Radio powers off for no apparent reason.	Radio may be experiencing very low voltage.	Have the battery checked by an authorized technician.
Radio will not transmit.	Radio may be out of coverage area or may be overheated.	Return to coverage area if possible. If overheated, let radio cool before retrying transmission. Report this failure to an authorized technician.
 <p>CAUTION</p>	<p>Though none of the above symptoms or solutions require disassembling the radio, this is a reminder that Harris recommends the radio should only be disassembled by Harris-authorized and certified service personnel. More importantly, if the radio is covered by Immersion-Rated Option MAEV-PKGMR, then the radio must be serviced by Harris authorized and certified service personnel. This is a requirement to maintain the watertight integrity warranted under Immersion Option MAEV-PKGMR.</p>	

10 CUSTOMER SERVICE

10.1 CUSTOMER CARE

If any part of the system equipment is damaged on arrival, contact the shipper to conduct an inspection and prepare a damage report. Save the shipping container and all packing materials until the inspection and the damage report are completed. In addition, contact the Customer Care center to make arrangements for replacement equipment. Do not return any part of the shipment until you receive detailed instructions from a Harris representative.

Contact the Customer Care center at <http://www.pspc.harris.com/CustomerService> or:

North America:

Phone Number: 1-800-368-3277

Fax Number: 1-321-409-4393

E-mail: PSPC_CustomerFocus@harris.com

International:

Phone Number: 1-434-455-6403

Fax Number: 1-321-409-4394

E-mail: PSPC_InternationalCustomerFocus@harris.com

10.2 TECHNICAL ASSISTANCE

The Technical Assistance Center's (TAC) resources are available to help with overall system operation, maintenance, upgrades and product support. TAC is the point of contact when answers are needed to technical questions.

Product specialists, with detailed knowledge of product operation, maintenance and repair provide technical support via a toll-free (in North America) telephone number. Support is also available through mail, fax and e-mail.

For more information about technical assistance services, contact your sales representative, or call the Technical Assistance Center at:

North America: 1-800-528-7711

International: 1-434-385-2400

Fax: 1-434-455-6712

E-mail: PSPC_tac@harris.com

RECHARGEABLE BATTERY WARRANTY

- A. Harris Corporation, a Delaware Corporation, through its RF Communications Division (hereinafter "Seller") warrants to the original purchaser for use (hereinafter "Buyer") that nickel-cadmium, nickel-metal hydride, lithium-ion, and lithium-polymer batteries supplied by Seller shall be free from defects in material and workmanship, and shall conform to its published specifications for a period of twelve (12) months from the date of purchase.
- B. For purposes of this warranty, batteries shall be deemed defective if (1) the battery capacity is less than 80% rated capacity, or (2) the battery develops leakage.
- C. If any battery fails to meet the foregoing warranty, Seller shall correct the failure by issuing a replacement battery upon receipt of the defective battery at an Authorized Service Center (ASC) or Seller factory (for OpenSky[®] Equipment only).
- D. Replacement batteries shall be warranted only for the remaining unexpired warranty period of the original battery. This warranty becomes void if:
1. The battery has been subjected to any kind of misuse, detrimental exposure, or has been involved in an accident.
 2. The battery is used in equipment or service other than the radio equipment for which it is specified.
- E. The preceding paragraphs set forth the exclusive remedies for claims based upon defects in or non-conformity of any battery, whether the claim is in contract, warranty, tort (including negligence), strict liability or otherwise, and however instituted. Upon the expiration of the warranty period, all such liability shall terminate. The foregoing warranties are exclusive and in lieu of all other warranties, whether oral, written, expressed, implied or statutory. NO IMPLIED OR STATUTORY WARRANTIES OF MERCHANTABILITY OR FITNESS FOR PARTICULAR PURPOSE SHALL APPLY. IN NO EVENT SHALL THE COMPANY BE LIABLE FOR ANY INCIDENTAL, CONSEQUENTIAL, SPECIAL, INDIRECT OR EXEMPLARY DAMAGES.

This warranty applies only within the United States.

To obtain the name and address of an Authorized Service Center (ASC), ask your salesperson, or call one of the factory number(s) printed at the bottom of this page.

Harris Corporation
RF Communications Division
221 Jefferson Ridge Parkway
Lynchburg, VA 24501
1-800-528-7711

Harris Corporation
RF Communications Division
1680 University Avenue
Rochester, NY 14610
1-585-244-5830

ECR-7048D

WARRANTY

Please register this product within 10 days of purchase. Registration validates the warranty coverage, and enables Harris to contact you in case of any safety notifications issued for this product.

Registration can be made on-line at <http://www.pspc.harris.com/Service/WarrantySupport.asp>

- A. Harris Corporation, a Delaware Corporation, through its RF Communications Division (hereinafter "Seller") warrants to the original purchaser for use (hereinafter "Buyer") that Equipment manufactured by or for the Seller shall be free from defects in material and workmanship, and shall conform to its published specifications. With respect to all non-Seller Equipment, Seller gives no warranty, and only the warranty, if any, given by the manufacturer shall apply. Rechargeable batteries are excluded from this warranty but are warranted under a separate Rechargeable Battery Warranty (ECR-7048).
- B. Seller's obligations set forth in Paragraph C below shall apply only to failures to meet the above warranties occurring within the following periods of time from date of sale to the Buyer and are conditioned on Buyer's giving written notice to Seller within thirty (30) days of such occurrence:
1. for fuses and non-rechargeable batteries, operable on arrival only.
 2. for parts and accessories (except as noted in B.1), ninety (90) days.
 3. for P7300, P7200, P7100^{IP}, P5400, P5300, P5200, P5100, P3300, M7300, M7200 (including V-TAC), M7100^{IP}, M5300 and M3300 radios, two (2) years, effective 10/01/2007.
 4. for Unity[®] XG-100P, three (3) years.
 5. for all other equipment of Seller's manufacture, one (1) year.
- C. If any Equipment fails to meet the foregoing warranties, Seller shall correct the failure at its option (i) by repairing any defective or damaged part or parts thereof, (ii) by making available at Seller's factory any necessary repaired or replacement parts, or (iii) by replacing the failed Equipment with equivalent new or refurbished Equipment. Any repaired or replacement part furnished hereunder shall be warranted for the remainder of the warranty period of the Equipment in which it is installed. Where such failure cannot be corrected by Seller's reasonable efforts, the parties will negotiate an equitable adjustment in price. Labor to perform warranty service will be provided at no charge during the warranty period only for the Equipment covered under Paragraph B.3 and B.4. To be eligible for no-charge labor, service must be performed at Seller's factory, by an Authorized Service Center (ASC) or other Servicer approved for these purposes either at its place of business during normal business hours, for mobile or personal equipment, or at the Buyer's location, for fixed location equipment. Service on fixed location equipment more than thirty (30) miles from the Service Center or other approved Servicer's place of business will include a charge for transportation.
- D. Seller's obligations under Paragraph C shall not apply to any Equipment, or part thereof, which (i) has been modified or otherwise altered other than pursuant to Seller's written instructions or written approval or, (ii) is normally consumed in operation or, (iii) has a normal life inherently shorter than the warranty periods specified in Paragraph B, or (iv) is not properly stored, installed, used, maintained or repaired, or, (v) has been subjected to any other kind of misuse or detrimental exposure, or has been involved in an accident.
- E. The preceding paragraphs set forth the exclusive remedies for claims based upon defects in or nonconformity of the Equipment, whether the claim is in contract, warranty, tort (including negligence), strict liability or otherwise, and however instituted. Upon the expiration of the warranty period, all such liability shall terminate. The foregoing warranties are exclusive and in lieu of all other warranties, whether oral, written, expressed, implied or statutory. NO IMPLIED OR STATUTORY WARRANTIES OF MERCHANTABILITY OR FITNESS FOR PARTICULAR PURPOSE SHALL APPLY. IN NO EVENT SHALL THE SELLER BE LIABLE FOR ANY INCIDENTAL, CONSEQUENTIAL, SPECIAL, INDIRECT OR EXEMPLARY DAMAGES.

This warranty applies only within the United States.

Harris Corporation
RF Communications Division
221 Jefferson Ridge Parkway
Lynchburg, VA 24501
1-800-528-7711

Harris Corporation
RF Communications Division
1680 University Avenue
Rochester, NY 14610
1-585-244-5830

ECR-7047L



Product Safety Manual

14221-1100-2020

Aug/11



This booklet contains important safety information regarding specific absorption rate (SAR) and RF exposure limits included in United States and international standards. Read the information in this booklet before operating your radio.

XG-75 Series Portable Radios

REV	DATE	DESCRIPTION
-	Aug/11	Initial release

ACKNOWLEDGEMENTS

The software contained in this device is copyrighted by Harris Corporation. Unpublished rights are reserved under the copyright laws of the United States.

This device is made under license under one or more of the following US patents: 4,590,473; 4,636,791; 5,148,482; 5,185,796; 5,271,017; 5,377,229; 4,716,407; 4,972,460; 5,502,767; 5,146,497; 5,164,986; 5,185,795; 5,226,084; 5,247,579; 5,491,772; 5,517,511; 5,630,011; 5,649,050; 5,701,390; 5,715,365; 5,754,974; 5,826,222; 5,870,405; 6,161,089; and 6,199,037 B1. DVSI claims certain rights, including patent rights under aforementioned U.S. patents, and under other U.S. and foreign patents and patents pending. Any use of this software or technology requires a separate written license from DVSI.

CREDITS

Harris, EDACS, OpenSky, and assuredcommunications are registered trademarks and ProVoice is a trademark of Harris Corporation.

RBRC and 1-800-8-BATTERY are registered trademarks of Rechargeable Battery Recycling Corporation.

AMBE is a registered trademark and IMBE, AMBE+, and AMBE+2 are trademarks of Digital Voice Systems, Inc.

All other product and brand names are trademarks, registered trademarks, or service marks of their respective holders.

NOTICE

The material contained herein is subject to U.S. export approval. No export or re-export is permitted without written approval from the U.S. Government. Rated: EAR99; in accordance with U.S. Dept. of Commerce regulations 15CFR774, Export Administration Regulations.

Information and descriptions contained herein are the property of Harris Corporation. Such information and descriptions may not be copied or reproduced by any means, or disseminated or distributed without the express prior written permission of Harris Corporation, PSC Division, 221 Jefferson Ridge Parkway, Lynchburg, VA 24501.



This product conforms to the European Union WEEE Directive 2002/96/EC. Do not dispose of this product in a public landfill. This product should be taken to a recycling center at the end of its life.

The voice coding technology embodied in this product is protected by intellectual property rights including patent rights, copyrights, and trade secrets of Digital Voice Systems, Inc. The user of this technology is explicitly prohibited from attempting to decompile, reverse engineer, or disassemble the Object Code, or in any other way convert the Object Code into human-readable form.

Repairs to this equipment should be made only by an authorized service technician or facility designated by the supplier. Any repairs, alterations, or substitution of recommended parts made by the user to this equipment not approved by the manufacturer could void the user's authority to operate the equipment in addition to the manufacturer's warranty.

This manual is published by **Harris Corporation**, without any warranty. Improvements and changes to this manual necessitated by typographical errors, inaccuracies of current information, or improvements to programs and/or equipment, may be made by **Harris Corporation**, at any time and without notice. Such changes will be incorporated into new editions of this manual. No part of this manual may be reproduced or transmitted in any form or by any means, electronic or mechanical, including photocopying and recording, for any purpose, without the express written permission of **Harris Corporation**.

Copyright © 2011 Harris Corporation.

TABLE OF CONTENTS

	<i>Page</i>
1. SAFETY SYMBOL CONVENTIONS	4
2. SAFETY TRAINING INFORMATION	5
2.1 RF EXPOSURE GUIDELINES.....	5
2.2 ELECTROMAGNETIC INTERFERENCE/COMPATIBILITY....	6
2.3 REGULATORY APPROVALS	7
3. OPERATING TIPS.....	7
4. EFFICIENT RADIO OPERATION.....	8
4.1 ANTENNA CARE AND REPLACEMENT	8
4.2 ELECTRONIC DEVICES	8
5. OPTIONS AND ACCESSORIES	9
6. BATTERY PACKS.....	10
6.1 CONDITIONING NIMH BATTERY PACKS.....	10
6.2 CONDITIONING LI-ION BATTERY PACKS	10
6.3 ADDITIONAL INFORMATION	10
6.4 BATTERY DISPOSAL	11
7. IMMERSIBLE XG-75 PREVENTIVE MAINTENANCE	11
8. TECHNICAL ASSISTANCE.....	12
9. WARRANTY.....	12

Harris Corporation, Public Safety and Professional Communications (PSPC) Business continually evaluates its technical publications for completeness, technical accuracy, and organization. You can assist in this process by submitting your comments and suggestions to the following:

Harris Corporation

PSPC Business

or fax your comments to: 1-434-455-6851

Technical Publications

221 Jefferson Ridge Parkway

or e-mail us at: PSPC-techpubs@harris.com

Lynchburg, VA 24501

1. SAFETY SYMBOL CONVENTIONS

The following conventions are used to alert the user to general safety precautions that must be observed during all phases of operation, service, and repair of this product. Failure to comply with these precautions or with specific warnings elsewhere violates safety standards of design, manufacture, and intended use of the product. Harris Corporation assumes no liability for the customer's failure to comply with these standards.



The **WARNING** symbol calls attention to a procedure, practice, or the like, which, if not correctly performed or adhered to, could result in personal injury. Do not proceed beyond a **WARNING** symbol until the conditions identified are fully understood or met.



The **CAUTION** symbol calls attention to an operating procedure, practice, or the like, which, if not performed correctly or adhered to, could result in a risk of danger, damage to the equipment, or severely degrade the equipment performance.



The **NOTE** symbol calls attention to supplemental information, which may improve system performance or clarify a process or procedure.



The **ESD** symbol calls attention to procedures, practices, or the like, which could expose equipment to the effects of **E**lectro-**S**tatic **D**ischarge. Proper precautions must be taken to prevent ESD when handling circuit modules.

2. SAFETY TRAINING INFORMATION



The Harris Corporation XG-75 portable radio generates RF electromagnetic energy during transmit mode. This radio is designed for and classified as “Occupational Use Only,” meaning it must be used only during the course of employment by individuals aware of the hazards and the ways to minimize such hazards. This radio is NOT intended for use by the “General Population” in an uncontrolled environment.

The XG-75 portable radio has been tested and complies with the FCC RF exposure limits for “Occupational Use Only.” In addition, this radio complies with the following Standards and Guidelines with regard to RF energy and electromagnetic energy levels and evaluation of such levels for exposure to humans:

- FCC OET Bulletin 65 Edition 97-01 Supplement C, Evaluating Compliance with FCC Guidelines for Human Exposure to Radio Frequency Electromagnetic Fields.
- American National Standards Institute (C95.1 – 1992), IEEE Standard for Safety Levels with Respect to Human Exposure to Radio Frequency Electromagnetic Fields, 3 kHz to 300 GHz.
- American National Standards Institute (C95.3 – 1992), IEEE Recommended Practice for the Measurement of Potentially Hazardous Electromagnetic Fields – RF and Microwave.

2.1 RF EXPOSURE GUIDELINES



To ensure that exposure to RF electromagnetic energy is within the FCC allowable limits for occupational use, always adhere to the following guidelines:

- DO NOT operate the radio without a proper antenna attached, as this may damage the radio and may also cause the FCC RF exposure limits to be exceeded. A proper antenna is the antenna supplied with this radio by Harris or an antenna specifically authorized by Harris Corporation for use with this radio.
- DO NOT transmit for more than 50% of total radio use time (“50% duty cycle”). Transmitting more than 50% of the time can cause FCC RF exposure compliance requirements to be exceeded. The radio is transmitting when the “TX” indicator appears in the display. The radio will transmit by pressing the “PTT” (Push-To-Talk) button.

- ALWAYS transmit using low power when possible. In addition to conserving battery charge, low power can reduce RF exposure.
- ALWAYS use Harris authorized accessories (antennas, batteries, belt clips, speaker/mics, etc). Use of unauthorized accessories may cause the FCC Occupational/Controlled Exposure RF compliance requirements to be exceeded.
- As noted in Table 2-1, ALWAYS keep the device and its antenna **AT LEAST** 1.6 cm (0.63 inches) from the body and at least 2.5 cm (1.00 inch) from the face when transmitting to ensure FCC RF exposure compliance requirements are not exceeded. However, to provide the best sound quality to the recipients of your transmission, Harris Corporation recommends you hold the microphone at least 5 cm (2 inches) from your mouth, and slightly off to one side.

Table 2-1: RF Exposure Compliance Tested Distances

RADIO FREQUENCY BAND	TESTED DISTANCES (worst case scenario)	
	Body	Face
VHF (136 - 174 MHz)	1.6 cm	2.5 cm
UHF-L (378-403 MHz)	1.6 cm	2.5 cm

Table 2-2: Distance from Body for Different Carrying Options

CARRYING CONFIGURATION	TESTED DISTANCES (WORST CASE FROM BODY)
Belt Loop	4.2 cm
Belt Clip	1.8 cm
Leather Case with Belt Loop	5.2 cm
Nylon Case with Belt Loop	4.5 cm
Shoulder Strap with D-clip	3.0 cm
Speaker-microphone with antenna	1.6 cm

The information in this section provides the information needed to make the user aware of a RF exposure, and what to do to assure that this radio operates within the FCC RF exposure limits of this radio.

2.2 ELECTROMAGNETIC INTERFERENCE/COMPATIBILITY

During transmissions, Harris radios generate RF energy that can possibly cause interference with other devices or systems. To avoid such interference, turn off the radios in areas where signs are posted to do so. DO NOT operate the transmitter in areas that are sensitive to electromagnetic radiation such as hospitals, aircraft, and blasting sites.

2.3 REGULATORY APPROVALS

2.3.1 Part 15

This device complies with Part 15 of the FCC Rules. Operation is subject to the following two conditions:

1. This device may not cause harmful interference, and
2. This device must accept any interference received, including interference that may cause undesired operation.

2.3.2 Industry Canada

This device complies with Industry Canada license-exempt RSS standard(s). Operation is subject to the following two conditions: (1) this device may not cause interference, and (2) this device must accept any interference, including interference that may cause undesired operation of the device.

Le présent appareil est conforme aux CNR d'Industrie Canada applicables aux appareils radio exempts de licence. L'exploitation est autorisée aux deux conditions suivantes : (1) l'appareil ne doit pas produire de brouillage, et (2) l'utilisateur de l'appareil doit accepter tout brouillage radioélectrique subi, même si le brouillage est susceptible d'en compromettre le fonctionnement.

3. OPERATING TIPS

Antenna location and condition are important when operating a portable radio. Operating the radio in low lying areas or terrain, under power lines or bridges, inside of a vehicle or in a metal framed building can severely reduce the range of the unit. Mountains can also reduce the range of the unit.

In areas where transmission or reception is poor, some improvement may be obtained by ensuring the antenna is vertical. Moving a few yards in another direction or moving to a higher elevation may also improve communications. Vehicular operation can be aided with the use of an externally mounted antenna.

Battery condition is another important factor in the trouble free operation of a portable radio. Always properly charge the batteries.

4. EFFICIENT RADIO OPERATION

Keep the antenna in a vertical position when receiving or transmitting a message.



Do NOT hold onto the antenna when the radio is powered on.

4.1 ANTENNA CARE AND REPLACEMENT



Always keep the antenna at least 0.43 inches (1.1 cm) away from the body and 1.0 inch (2.5 cm) from the face when transmitting to ensure FCC RF exposure compliance requirements are not exceeded.



Do not use the portable radio with a damaged or missing antenna. A minor burn may result if skin comes into contact with a damaged antenna. Replace a damaged antenna immediately. Operating a portable radio with the antenna missing could cause personal injury, damage the radio, and may violate FCC regulations.



Use only supplied or approved antennas. Use of unauthorized antennas, modifications, or attachments could cause damage to the radio unit and may violate FCC regulations.

4.2 ELECTRONIC DEVICES



RF energy from portable radios may affect some electronic equipment. Most modern electronic equipment in cars, hospitals, homes, etc. are shielded from RF energy. However, in areas in which you are instructed to turn off two-way radio equipment, always observe the rules. *If in doubt, turn it off!*

4.2.1 Aircraft



Always turn off a portable radio before boarding any aircraft!

- Use it on the ground only with crew permission.
- DO NOT use while in-flight!!

4.2.2 Electric Blasting Caps



To prevent accidental detonation of electric blasting caps, **DO NOT** use two-way radios within 1000 feet of blasting operations. Always obey the "Turn Off Two-Way Radios" signs posted where electric blasting caps are being used. (OSHA Standard: 1926.900)

4.2.3 Potentially Explosive Atmospheres



Areas with potentially explosive atmospheres are often, but not always, clearly marked. These may be fuelling areas, such as gas stations, fuel or chemical transfer or storage facilities, and areas where the air contains chemicals or particles, such as grain, dust, or metal powders.

Sparks in such areas could cause an explosion or fire resulting in bodily injury or even death.

Turn OFF two-way radios when in any area with a potentially explosive atmosphere. It is rare, but not impossible that a radio or its accessories could generate sparks.

5. OPTIONS AND ACCESSORIES

A complete list of Options and Accessories approved for use with the XG-75 portable radio can be found online in the Operator's Manual 14221-1100-2010 at www.pspc.harris.com. Also reference the maintenance manual or Harris Corporation's Products and Services Catalog for all available options and accessories, including those items that do not adversely affect the RF energy exposure.



Always use Harris authorized accessories (antennas, batteries, belt clips, speaker/mics, etc). Use of unauthorized accessories may cause the FCC Occupational/Controlled Exposure RF compliance requirements to be exceeded.



Always use the correct options and accessories (battery, antenna, speaker/mic, etc.) for the radio. Immersion rated options must be used with an immersion rated radio. Intrinsically safe options must be used with intrinsically safe radios.

6. BATTERY PACKS

The XG-75 series portable radios use rechargeable, recyclable Nickel Metal Hydride (NiMH) and Lithium Ion (Li-Ion) battery packs. Please follow the directions below to maximize the useful life of each type of battery pack.



Do not disassemble or modify Lithium Ion battery packs. The Lithium Ion battery packs are equipped with built-in safety and protection features. Should these features be disabled or tampered with in any way, the battery pack can leak electrolyte, overheat, emit smoke, burst, and/or ignite.



If the battery pack is ruptured or is leaking electrolyte that results in skin or eye contact with the electrolyte, immediately flush the affected area with water. If the battery electrolyte gets in the eyes, flush with water for 15 minutes and consult a physician immediately.

6.1 CONDITIONING NIMH BATTERY PACKS

Condition a new NiMH battery pack before putting into use. This also applies to rechargeable NiMH battery packs that have been stored for long periods (weeks, months, or longer). Conditioning requires fully charging and fully discharging the battery pack three (3) times using the tri-chemistry charger. The first time the battery pack is put into the charger, this unit will condition Nickel-based battery packs by automatically charging and discharging (cycling) the battery. Refer to the appropriate charger manual for details.



Failure to properly condition NiMH battery packs before initial use will result in shortened performance by the battery.

6.2 CONDITIONING LI-ION BATTERY PACKS

Lithium Ion battery packs do not suffer from memory effect and therefore do not require conditioning.



Always use Harris authorized chargers and conditioners. Use of unauthorized chargers and conditioners may void the warranty.

6.3 ADDITIONAL INFORMATION

For more information regarding the proper care of portable radio battery packs or establishing a battery maintenance program, refer to ECR-7367 which may be ordered by calling toll free 1-800-368-3277, then select option 7.

6.4 BATTERY DISPOSAL



In no instance should a battery pack be incinerated. Disposing of a battery pack by burning will cause an explosion.



RECHARGEABLE BATTERY PACK DISPOSAL – The product you have purchased contains a rechargeable battery pack. The battery pack is recyclable. At the end of its useful life, under various state and local laws, it may be illegal to dispose of this battery pack into the municipal waste stream. Check with your local solid waste officials for details in your area for recycling options or proper disposal. Canadian and U.S. users may call Toll Free 1-800-8-BATTERY® for information and/or procedures for returning rechargeable batteries in your locality.

7. IMMERSIBLE XG-75 PREVENTIVE MAINTENANCE

Preventive Maintenance for Immersion-Rated Radios



XG-75 model radios with Immersion Option MAEV-PKGMR must be serviced by a service center authorized and certified by Harris to perform the necessary tests to verify watertight integrity. As part of a thorough preventive maintenance plan, Harris Corporation recommends Immersion-Rated XG-75 portable radios, at a minimum, be tested and re-certified on an annual basis. Harris Corporation further recommends that the radios be tested on or close to the anniversary of the ship date printed on the Model Number label on the back of the radio.

8. TECHNICAL ASSISTANCE

The Technical Assistance Center's (TAC's) resources are available to help with overall system operation, maintenance, upgrades and product support. TAC is your point of contact when answers are needed to technical questions.

Product specialists, with detailed knowledge of product operation, maintenance, and repair, provide technical support via a toll-free (in North America) telephone number. Support is also available through mail, fax and e-mail.

For more information about technical assistance services, contact your sales representative, or call the Technical Assistance Center directly at:

North America:	1-800-528-7711
International:	1-434-385-2400
Fax:	1-434-455-6712
E-mail:	PSPC-tac@harris.com

9. WARRANTY

Please register this product within 10 days of purchase. Registration validates the warranty coverage, and enables Harris to contact you in case of any safety notifications issued for this product.

Registration can be made on-line at www.pspc.harris.com/CustomerService.

RECHARGEABLE BATTERY WARRANTY

- A. Harris Corporation, a Delaware Corporation, through its RF Communications Division (hereinafter "Seller") warrants to the original purchaser for use (hereinafter "Buyer") that nickel-cadmium, nickel-metal hydride, lithium-ion, and lithium-polymer batteries supplied by Seller shall be free from defects in material and workmanship, and shall conform to its published specifications for a period of twelve (12) months from the date of purchase.
- B. For purposes of this warranty, batteries shall be deemed defective if (1) the battery capacity is less than 80% rated capacity, or (2) the battery develops leakage.
- C. If any battery fails to meet the foregoing warranty, Seller shall correct the failure by issuing a replacement battery upon receipt of the defective battery at an Authorized Service Center (ASC) or Seller factory (for OpenSky[®] Equipment only).
- D. Replacement batteries shall be warranted only for the remaining unexpired warranty period of the original battery. This warranty becomes void if:
1. The battery has been subjected to any kind of misuse, detrimental exposure, or has been involved in an accident.
 2. The battery is used in equipment or service other than the radio equipment for which it is specified.
- E. The preceding paragraphs set forth the exclusive remedies for claims based upon defects in or non-conformity of any battery, whether the claim is in contract, warranty, tort (including negligence), strict liability or otherwise, and however instituted. Upon the expiration of the warranty period, all such liability shall terminate. The foregoing warranties are exclusive and in lieu of all other warranties, whether oral, written, expressed, implied or statutory. **NO IMPLIED OR STATUTORY WARRANTIES OF MERCHANTABILITY OR FITNESS FOR PARTICULAR PURPOSE SHALL APPLY. IN NO EVENT SHALL THE COMPANY BE LIABLE FOR ANY INCIDENTAL, CONSEQUENTIAL, SPECIAL, INDIRECT OR EXEMPLARY DAMAGES.**

This warranty applies only within the United States.

To obtain the name and address of an Authorized Service Center (ASC), ask your salesperson, or call one of the factory number(s) printed at the bottom of this page.

Harris Corporation
RF Communications Division
221 Jefferson Ridge Parkway
Lynchburg, VA 24501
1-800-528-7711

Harris Corporation
RF Communications Division
1680 University Avenue
Rochester, NY 14610
1-585-244-5830

ECR-7048D

WARRANTY

- A. Harris Corporation, a Delaware Corporation, through its RF Communications Division (hereinafter "Seller") warrants to the original purchaser for use (hereinafter "Buyer") that Equipment manufactured by or for the Seller shall be free from defects in material and workmanship, and shall conform to its published specifications. With respect to all non-Seller Equipment, Seller gives no warranty, and only the warranty, if any, given by the manufacturer shall apply. Rechargeable batteries are excluded from this warranty but are warranted under a separate Rechargeable Battery Warranty (ECR-7048).
- B. Seller's obligations set forth in Paragraph C below shall apply only to failures to meet the above warranties occurring within the following periods of time from date of sale to the Buyer and are conditioned on Buyer's giving written notice to Seller within thirty (30) days of such occurrence:
1. for fuses and non-rechargeable batteries, operable on arrival only.
 3. for parts and accessories (except as noted in B.1), ninety (90) days.
 4. for P7300, P7200, P7100^{IP}, P5400, P5300, P5200, P5100, P3300, M7300, M7200 (including V-TAC), M7100^{IP}, M5300 and M3300 radios, two (2) years, effective 10/01/2007.
 5. for Unity[®] XG-100P, three (3) years.
 6. for all other equipment of Seller's manufacture, one (1) year.
- C. If any Equipment fails to meet the foregoing warranties, Seller shall correct the failure at its option (i) by repairing any defective or damaged part or parts thereof, (ii) by making available at Seller's factory any necessary repaired or replacement parts, or (iii) by replacing the failed Equipment with equivalent new or refurbished Equipment. Any repaired or replacement part furnished hereunder shall be warranted for the remainder of the warranty period of the Equipment in which it is installed. Where such failure cannot be corrected by Seller's reasonable efforts, the parties will negotiate an equitable adjustment in price. Labor to perform warranty service will be provided at no charge during the warranty period only for the Equipment covered under Paragraph B.3 and B.4. To be eligible for no-charge labor, service must be performed at Seller's factory, by an Authorized Service Center (ASC) or other Servicer approved for these purposes either at its place of business during normal business hours, for mobile or personal equipment, or at the Buyer's location, for fixed location equipment. Service on fixed location equipment more than thirty (30) miles from the Service Center or other approved Servicer's place of business will include a charge for transportation.
- D. Seller's obligations under Paragraph C shall not apply to any Equipment, or part thereof, which (i) has been modified or otherwise altered other than pursuant to Seller's written instructions or written approval or, (ii) is normally consumed in operation or, (iii) has a normal life inherently shorter than the warranty periods specified in Paragraph B, or (iv) is not properly stored, installed, used, maintained or repaired, or, (v) has been subjected to any other kind of misuse or detrimental exposure, or has been involved in an accident.
- E. The preceding paragraphs set forth the exclusive remedies for claims based upon defects in or nonconformity of the Equipment, whether the claim is in contract, warranty, tort (including negligence), strict liability or otherwise, and however instituted. Upon the expiration of the warranty period, all such liability shall terminate. The foregoing warranties are exclusive and in lieu of all other warranties, whether oral, written, expressed, implied or statutory. NO IMPLIED OR STATUTORY WARRANTIES OF MERCHANTABILITY OR FITNESS FOR PARTICULAR PURPOSE SHALL APPLY. IN NO EVENT SHALL THE SELLER BE LIABLE FOR ANY INCIDENTAL, CONSEQUENTIAL, SPECIAL, INDIRECT OR EXEMPLARY DAMAGES.

This warranty applies only within the United States.

Harris Corporation
RF Communications Division
221 Jefferson Ridge Parkway
Lynchburg, VA 24501
1-800-528-7711

Harris Corporation
RF Communications Division
1680 University Avenue
Rochester, NY 14610
1-585-244-5830

ECR-7047L

NOTES