



DM-20

OEM INTERFACE MANUAL

CONTENTS – OEM INTERFACE MANUAL

1. DM20 TRANSCEIVER MODULE OUTLINE DRAWING 3

1.1. MECHANICAL 4

1.2. ELECTRICAL 5

1.2.1. ELECTRICAL PERFORMANCE..... 5

1.2.2. MOBILE STATION POWER CLASS 6

1.3. POWER CONSUMPTION..... 6

1.3.1. TRANSMIT/TALK MODE..... 6

1.3.2. STANDBY MODE 6

1.3.3. SLEEP MODE (MINIMUM DC POWER CONSUMPTION)..... 6

2. ABSOLUTE MAXIMUM RATINGS 7

3. SAFETY..... 8

3.1. EXPOSURE TO RADIO FREQUENCY ENERGY 8

3.2. MODULE OPERATION 8

3.3. POSTED FACILITIES 8

3.4. ELECTRONIC DEVICES..... 8

3.5. BLASTING AREAS 9

3.6. POTENTIALLY EXPLOSIVE ATMOSPHERES 9

3.7. VEHICLES..... 9

3.8. FOR VEHICLES EQUIPPED WITH AN AIRBAG..... 9

3.9. RESPONSIBLE USE 9

1. DM20 Transceiver Module Outline Drawing

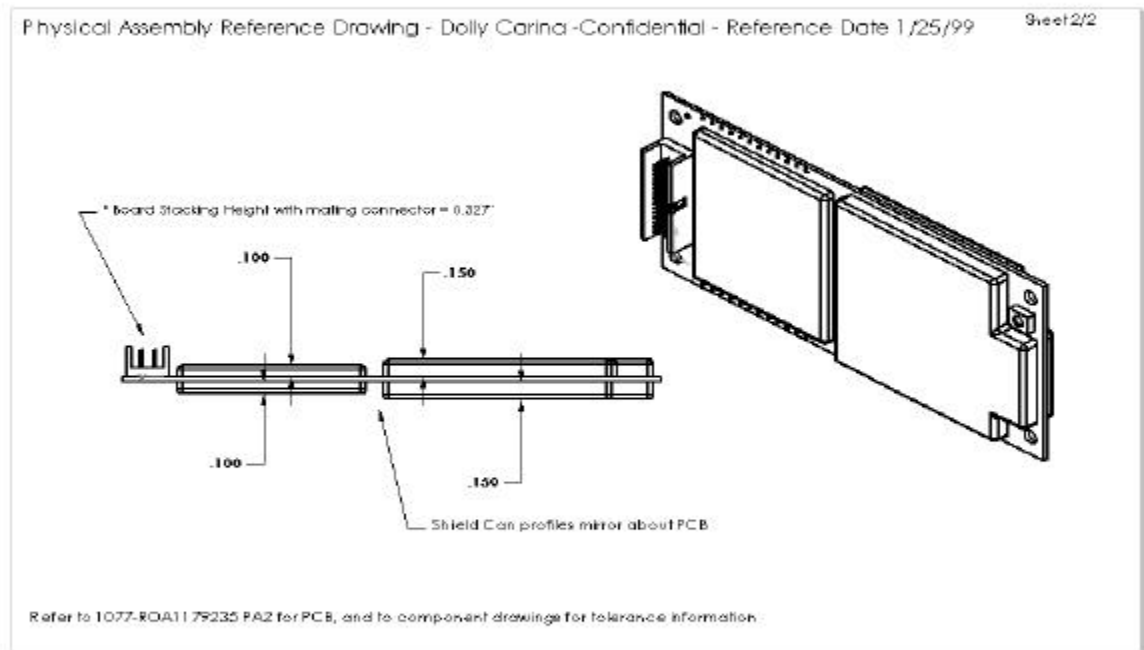

1.1. Mechanical

The DM-20 module has no mechanical elements other than the main PCB assembly. All critical electronic components are shielded using sheet metal cans to prevent internal/external electromagnetic interference from degrading the module's performance and to prevent the module from interfering with other nearby devices. The following figure shows a typical mounting configuration of the module with the main motherboard assembly. The module is plugged into the fixed mating connector and secured with four screws to the standoff components.

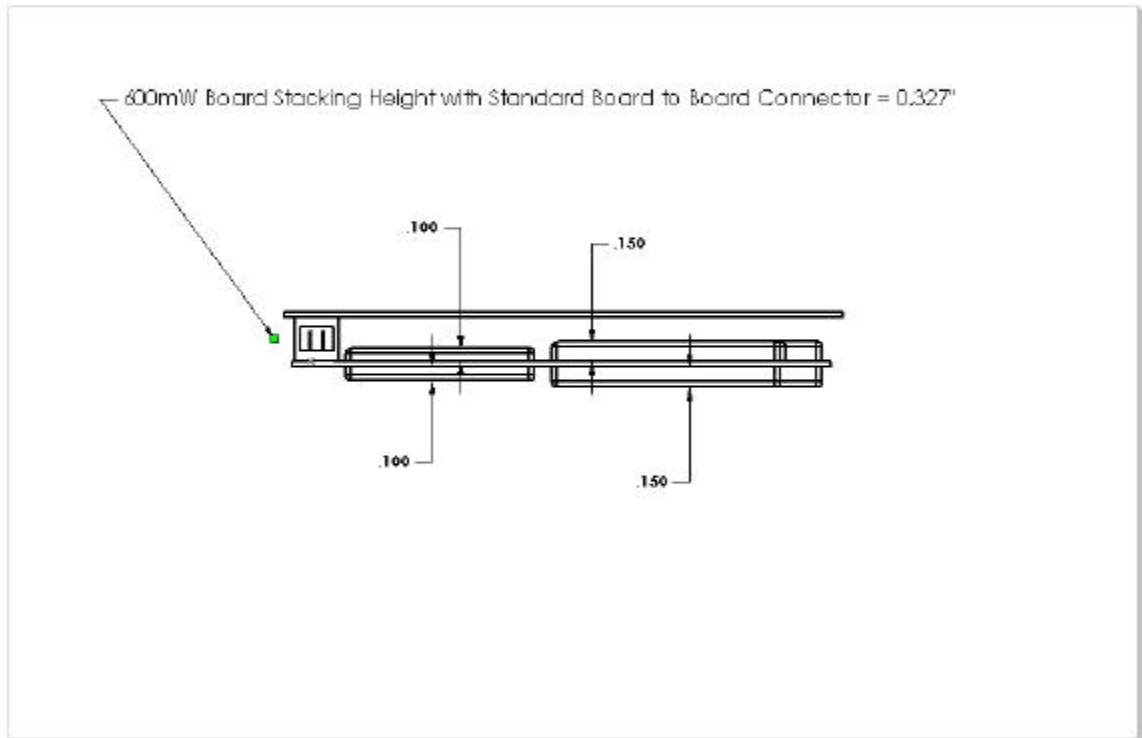

1.2. Electrical

The diagram below shows an overview of the electrical interface between the DM-20 module and a typical application.

DM-20 Electrical Interface

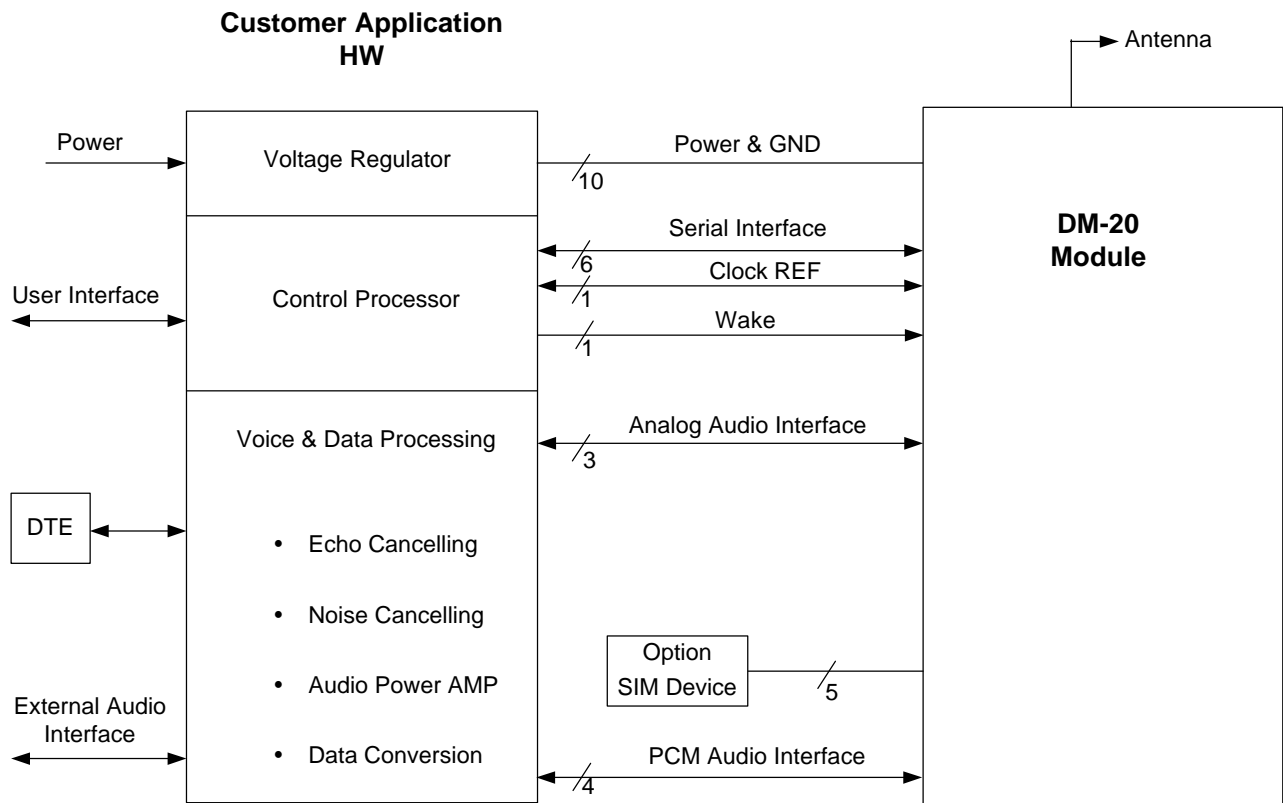

1.2.1. Electrical Performance

Electrical performance parameters are valid only when the terminating impedance at the output of the antenna connector exhibits a VSWR of less than 2:1 for all phase angles in the frequency band of operation. High VSWR loads at the antenna connector adversely affect current consumption, linearity, and power efficiency of the module and may prevent operation or cause internal damage.

The RF performance of the DM-20 fully meets the following specifications:

- IS-136 TDMA Cellular mode – Per IS-137 specification
- 553 AMPS Cellular mode – Per IS-19 specification

Exhibit 8: OEM Interface Manual

- CDPD Mode – Per Cellular Digital Packet Data (CDPD) System Specification, Release 1.1, 19 January 1995 (CDPD will be supported in a future release of the DM20).

1.2.2. Mobile Station Power Class

The module is able to operate in several modes and different output power levels. Typical applications require output power levels similar to those in a handheld cellular phone (600-mW nominal) which is considered a power class IV unit for dual mode operation. It is possible to increase the output power level to that of a class I unit (4 W nominal) during the 5 second analog burst data mode. The table below shows the nominal output power levels (Effective Radiated Power, assuming an antenna system gain of 1 dBd (3.15 dBi) [2.5 dBd (4.65 dBi) antenna gain with 1.5 dB cable loss]).

Mobile Station Nominal Power Levels

	Mobile Station Power Level (dBW)										
	0	1	2	3	4	5	6	7	8	9	10
Class I	6	2	-2	-6	-10	-14	-18	-22	-22	-22	-22
Class IV	-2	-2	-2	-6	-10	-14	-18	-22	-27±3	-32±4	-37±5

*Note: Output power levels maintained within range of +2 / -4 dB unless otherwise noted

Power levels 8-10 valid for digital mode only

1.3. Power Consumption

1.3.1. Transmit/Talk Mode

DC current in mA		AMPS Mode	IS-136 Mode	CDPD Mode
600 mWatt	Peak	617	590	590
	RMS	617	355	355
3 W Burst	Peak	1810	-	-

1.3.2. Standby Mode

DC current in mA	AMPS Mode	IS-136 Mode	CDPD Mode
RMS	36	15	15

1.3.3. Sleep Mode (Minimum DC Power consumption)

A power down or "sleep mode" is available in which the module is placed in a low power consumption state under control of the host application. In this mode, the unit consumes approximately 33 uA of current as measured from the VCC_6V supply input on pin 1 of the system connector. A logic level "0" on pin 19 of the system connector returns the unit to full operation although there may be a significant delay while the module reestablishes registration with the cellular network

Absolute Maximum Ratings

Parameter	Rating	Units
Supply voltage		
6.0 volts	5.2-6.8	Volts
13.6 volts	10.88-16.32	Volts
Operating temperature	-40 to +70	°C
Storage temperature	-40 to +85	°C

Safety

Exposure to Radio Frequency Signals

designed as or to be configured as a hand held device. Use as a portable transmitter will

module includes:

- remote electrical meter reading
- telematic communication for vehicles
- fixed wireless terminals

Warning:

1. At no time is the antenna to be located closer than 20 centimeters to a normally occupied location.
2. At no time should an antenna system with greater than 1.0 dBd (3.15 dBi) gain be used with this module in any normally occupied area. The recommended antenna system configuration is a standard automotive antenna with 2.5 dBd (4.65 dBi) antenna gain and 1.5 dB cable loss.

3.2. Module Operation

Safe and efficient use of this module requires a properly terminated antenna. DO NOT operate the module with a damaged or missing antenna, replace a damaged or missing antenna immediately otherwise damage to the module may result and could violate FCC regulations. DO NOT operate this device within 8 inches (20 cm) of a person unless proper shielding from the antenna is installed.

3.3. Posted Facilities

Do not operate this device where posted notices require wireless devices to be turned off.

3.4. Electronic Devices

Most electronic equipment is shielded from RF signals. However, certain electronic equipment may not be shielded properly against RF signals.

Pacemakers

The Health Industries Manufacturers Association recommends that a minimum separation of six (6) inches be maintained between a wireless transmitter and a pacemaker to avoid potential interference with the pacemaker. These recommendations are consistent with the independent research and recommendations of Wireless Technology Research. Persons with Pacemakers should always keep the antenna/module more than 6 inches from their pacemaker when the module is on; if you have a reason to suspect that interference is taking place, turn off the module immediately.

Hearing Aids

Some digital wireless devices may interfere with some hearing aids.

Other Medical Devices

If you use any other type of personal medical device in the presence of this transceiver, consult the manufacturer of your device to determine if it is adequately shielded from external RF energy. Your physician may be able to assist you in obtaining this information.

3.5. Blasting Areas

To avoid interfering with blasting operations, turn your module off when in a “blasting area” or in areas posted: “Turn off two-way radio”. Obey all signs and instructions.

3.6. Potentially Explosive Atmospheres

Turn your module off when in any area with a potentially explosive atmosphere and obey all signs and instructions. Sparks in such areas could cause an explosion or fire resulting in bodily injury or even death.

Areas with a potentially explosive atmosphere are often, but not always, clearly marked. They include such areas as gasoline stations; below deck on boats; fuel or chemical storage or transfer facilities; vehicles using liquefied petroleum gas (such as propane or butane); areas where the air contains chemicals or particles, such as grain dust or metal powders; and any other area where you would normally be advised to turn off your vehicle engine.

3.7. Vehicles

RF signals may affect improperly installed or inadequately shielded electronic systems in motor vehicles. Check with the manufacturer or its representative regarding your vehicle. You should also consult the manufacturer of any equipment that has been added to your vehicle.

3.8. For Vehicles Equipped with an Airbag

An airbag inflates with a great force. Do not place objects including both installed or portable wireless equipment in the area over the airbag or in the airbag deployment area. If in-vehicle wireless equipment is improperly installed and the airbag inflates, serious injury could result.

3.9. Responsible Use

OEM Manufacturers providing telematic devices for vehicular use are encouraged to incorporate the following CTIA guidance for safe and responsible wireless phone use into their user’s manuals:

A Guide to Safe and Responsible Wireless Phone Use

TENS OF MILLIONS OF PEOPLE IN THE U.S. TODAY TAKE ADVANTAGE OF THE UNIQUE COMBINATION OF CONVENIENCE, SAFETY AND VALUE

DELIVERED BY THE WIRELESS TELEPHONE. QUITE SIMPLY, THE WIRELESS PHONE GIVES PEOPLE THE POWERFUL ABILITY TO COMMUNICATE BY VOICE--ALMOST ANYWHERE, ANYTIME--WITH THE BOSS, WITH A CLIENT, WITH THE KIDS, WITH EMERGENCY PERSONNEL OR EVEN WITH THE POLICE. EACH YEAR, AMERICANS MAKE BILLIONS OF CALLS FROM THEIR WIRELESS PHONES, AND THE NUMBERS ARE RAPIDLY GROWING.

But an important responsibility accompanies those benefits, one that every wireless phone user must uphold. When driving a car, driving is your first responsibility. A wireless phone can be an invaluable tool, but good judgment must be exercised at all times while driving a motor vehicle--whether on the phone or not.

The basic lessons are ones we all learned as teenagers. Driving requires alertness, caution and courtesy. It requires a heavy dose of basic common sense---keep your head up, keep your eyes on the road, check your mirrors frequently and watch out for other drivers. It requires obeying all traffic signs and signals and staying within the speed limit. It means using seatbelts and requiring other passengers to do the same.

But with wireless phone use, driving safely means a little more. This brochure is a call to wireless phone users everywhere to make safety their first priority when behind the wheel of a car. Wireless telecommunications is keeping us in touch, simplifying our lives, protecting us in emergencies and providing opportunities to help others in need. When it comes to the use of wireless phones, safety is your most important call.

Wireless Phone "Safety Tips"

Below are safety tips to follow while driving and using a wireless phone, which should be easy to remember.

1. Get to know your wireless phone and its features such as speed dial and redial.

Carefully read your instruction manual and learn to take advantage of valuable features most phones offer, including automatic redial and memory. Also, work to memorize the phone keypad so you can use the speed dial function without taking your attention off the road.

2. When available, use a hands free device. A number of hands free wireless phone accessories are readily available today. Whether you choose an installed mounted device for your wireless phone or a speaker phone accessory, take advantage of these devices if available to you.

3. Position your wireless phone within easy reach. Make sure you place your wireless phone within easy reach and where you can grab it without removing your eyes from the road. If you get an incoming call at an inconvenient time, if possible, let your voice mail answer it for you.

4. Suspend conversations during hazardous driving conditions or situations. Let the person you are speaking with know you are driving; if necessary, suspend the call in heavy traffic or hazardous weather conditions. Rain, sleet, snow and ice can

be hazardous, but so is heavy traffic. As a driver, your first responsibility is to pay attention to the road.

- 5. Do not take notes or look up phone numbers while driving.** If you are reading an address book or business card, or writing a "to do" list while driving a car, you are not watching where you are going. It's common sense. Don't get caught in a dangerous situation because you are reading or writing and not paying attention to the road or nearby vehicles.
- 6. Dial sensibly and assess the traffic;** if possible, place calls when you are not moving or before pulling into traffic. Try to plan your calls before you begin your trip or attempt to coincide your calls with times you may be stopped at a stop sign, red light or otherwise stationary. But if you need to dial while driving, follow this simple tip--dial only a few numbers, check the road and your mirrors, then continue.
- 7. Do not engage in stressful or emotional conversations that may be distracting.** Stressful or emotional conversations and driving do not mix--they are distracting and even dangerous when you are behind the wheel of a car. Make people you are talking with aware you are driving and if necessary, suspend conversations, which have the potential to divert your attention from the road.
- 8. Use your wireless phone to call for help.** Your wireless phone is one of the greatest tools you can own to protect yourself and your family in dangerous situations--with your phone at your side, help is only three numbers away. Dial 9-1-1 or other local emergency number in the case of fire, traffic accident, road hazard or medical emergency. Remember that it is a free call on your wireless phone!
- 9. Use your wireless phone to help others in emergencies.** Your wireless phone provides you a perfect opportunity to be a "Good Samaritan" in your community. If you see an auto accident, crime in progress or other serious emergency where lives are in danger, call 9-1-1 or other local emergency number, as you would want others to do for you.
- 10. Call roadside assistance or a special wireless non-emergency assistance number when necessary.** Certain situations you encounter while driving may require attention but are not urgent enough to merit a call for emergency services. But you still can use your wireless phone to lend a hand. If you see a broken-down vehicle posing no serious hazard, a broken traffic signal, a minor traffic accident where no one appears injured or a vehicle you know to be stolen, call roadside assistance or other special non-emergency wireless number.

Careless, distracted individuals and people driving irresponsibly represent a hazard to everyone on the road. Since 1984, the Cellular Telecommunications Industry Association and the wireless industry have conducted educational outreach to inform wireless phone users of their responsibilities as safe drivers and good citizens. As we approach a new century, more and more of us will take advantage of the benefits of wireless telephones. And, as we take to the roads, we all have a responsibility to drive safely.