

User's Manual Tire Pressure Monitor TPM-S1/TPM-S2

TPM is one of the most advanced automobile tire pressure monitoring system. This system can automatically monitor your tires while you are driving your car. When any of the tire pressures fell under a safety level, the system will issue warning signals to notify you. The TPM can display individual tire pressures, which allows you to know your tire pressure situation at all time while you are driving. In addition, this system is very easy to install and very simple to operate. It enables you to always keep your tires properly inflated and, thereby, reduce your tire thread wears and prolong your tire lives. The best value TPM brings you is the peace of mind while driving, knowing that when you tires have problems, you will have advance warnings.

1 System Installation

1.1 System Parts

- Sensor Module
- Monitor Module
- Auxiliary Power Adapter
- DC power connector
- Connection cable

1.2 Sensor Module Installation

The product package includes four long-life button battery packs, one for each sensor module. To install the battery: open the sensor module cap by hand, insert the battery pack into the battery compartment, then close the sensor module cap. Be sure to install the battery with the proper polarity allocation, and make sure not to touch the electronics inside the sensor module for it might affect system operations.

On top of each sensor module cap there is a tire position mark, which:

- 1R, indicates that it is for the right-front tire;
- 2R, indicates that it is for the right-rear tire;
- 1L, indicates that it is for the left-front tire;
- 2L indicates that it is for the left-rear tire.
- 2RI indicates that it is for the right-rear inner tire (6 tire option).
- 2LI indicates that it is for the left-rear inner tire (6 tire option).

Replace each tire valve stem cap with a sensor module and then tighten the sensor module by hand. Make sure the sensor module is installed to the correct tire that is corresponded to its position indicator.

1.3 Tire Pressure Monitor Installation

Usually the monitor unit is placed on top of the dashboard, on the driver side near the windshield glass, with the display panel facing the driver. This way the power adaptor cable can run around the instrument panel and then go above or beneath the steering wheel, with the plug to be inserted into the cigarette lighter socket. The monitor unit can also be put inside the vehicle in any place that the user considered to be easily accessible.

2 How to Use the System

2.1 Monitor Module Display Panel

Please see the display panel drawing.

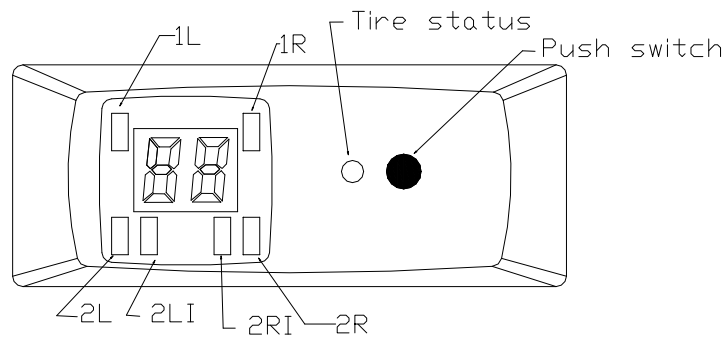

2.2 Initial Situation Display

In order to conserve the battery power inside the miniature sensor module, the sensor is shut down (i.e., not operational) when the automobile is stationary or when its speed is less than 15 miles per hour (mph). When the car speed reached 15 mph or above, all sensor modules installed on the vehicle tires will automatically turn on and enter the operation mode, and will immediately transmit the tire pressure reading to the monitor unit. Upon receiving the pressure readings, the monitor will display individual tire pressures, one after another, to notify the user. In every 4 seconds, the display panel will show tire pressures in the following (clockwise) order: right-front tire (1R), right-rear tire (2R), right-rear inner (2RI, option), left rear (2LI, option), left rear (2L), and left front (1L). At this time if the automobile speed maintained at 15 mph or higher, the individual tire pressures will be displayed twice, in two cycles. The initial situation display allows the user to learn about each tire's pressure condition when the vehicle is picking up speed. After completion of the initial display, in order not to distract the driver, the system will enter automatic monitoring mode and will not display any normal pressure readings; only the green LED on the monitor is lit to indicate the system is operational.

The initial situation display will repeat each time when the car moves from lower speed to above 15 mph. During this display, if the vehicle suddenly stops or is reducing speed to below 15 mph, some or all the sensors might automatically be turned off and, as a result, the monitor may not be able to receive transmission from the sensors. If the display consistently not shown the icon for a tire, however, the user should find out whether the sensor is still operational or is lost. Strong electromagnetic field could interfere with the transmission and reception of the wireless signal and, therefore, the user must aware the interference from the environment. (See Function Description 2)

2.3 Automatic Monitoring Mode

After exiting from the initial display mode and entering into the automatic monitoring mode, the pressure sensors will monitor each tire's pressure at every 4 seconds. Upon detection of any pressure changes exceeding a preset delta value, the sensors will immediately transmit a code with new parameters to the monitor. The monitor will update its database with the new pressure readings, but will not display it. However, if the new parameter indicates a pressure lower than the low-tire-pressure-warning threshold, the monitor will immediately sound an 8-second audio warning signal. In addition, the monitor will change the color of the status LED from green to red. At the same time, the corresponding tire position indicator on the display panel will also light up in red. And to maintain the red status display, until the system determines that the tire pressure is back to its normal range. It will display any pressure change +/- 3 PSI on the tire during the automatic monitoring mode.

2.4 Monitor Button-Switch Operation

2.4.1 Display Tire Pressure Readings

Each pressing of the button-switch on the monitor front panel will trigger the display of a tire pressure, accompanied with the glowing in red of the tire position indicator. Pressing the button-switch again will trigger the pressure display for the next tire. Eight (8) seconds after the last button-switch pressing, the pressure display will automatically be turned off in order to conserve power.

2.4.2 Reset Monitor to Original Setting

After pressing and holding the button-switch for three (3) seconds, any warning light and audio signal will be cleared, and the monitor will return to the original operation settings.

2.4.3 Setup User Designated Low Pressure Warning Threshold

First remove the power supply (e.g., unplug power adapter from the cigarette lighter socket). Next, restore the power supply while pressing and holding the button-switch. Continue to press and hold the button-switch for three (3) seconds and then release it. At this time, all four of the tire position indicators will glow in red, and the reading shows the current setting for triggering the low-pressure warning. The setting can now be

adjusted by pressing the button-switch: each pressing increases the pressure setting by 1 PSI until reaching the maximum 90 PSI, then the setting will cycle back to the factory default setting of 18 PSI. When the setting reaches your desired pressure, you may hold the button-switch for three (3) seconds to save the setting into the system memory and to exit the setup mode.

Note: When the setting reaches your desired pressure of, say, 22 PSI, do not release the button-switch but continue to hold; in three (3) seconds the system will save the new setting and exit the setup mode automatically. If you release the button-switch and then press again for 3 seconds, the setting might increase to the next higher pressure value (e.g., 23 PSI.)

3 Sensor Module Maintenance

3.1 Sensor Module Low Battery

Each tire pressure sensor module contains a long-life battery pack, which has the normal usage life of more than 1.5 year for TPM-S1 and 5 years for TPM-S2, respectively. When any of the tire sensor modules detected that the battery voltage is lower than the operating level, it will not transmit signals to the monitor. If you find out any one of the tire did not have pressure reading and its sensor module is not lost, you must replace the battery pack of that particular sensor module to insure the proper working condition of the system.

3.2 Sensor Module Damage or Lost Indication

Each time when the car starts and the monitor displays initial pressure readings, if any tire position readings continuously not shown a pressure value, then the sensor module for that tire could be lost, or the wireless signal transmission was interrupted by external radio frequency interference. After the driving speed continuously surpassed 15 mph for more than 30-60 minutes, if the monitor still not received pressure reading from the tires, then the corresponding tire position indicator on the display panel will start flashing, indicating to the user than the sensor module could be damaged or lost.

4 FCC Compliance

This equipment has been tested and found to comply with the limits for a class B digital device, pursuant to part 15 of the FCC Rules. These limits are designed to provide reasonable protection against harmful interference in a residential installation. This equipment generates, uses and can radiate radio frequency energy and if not installed and used in accordance with the instructions, may cause harmful interference to radio communications. However, there is no guarantee that interference will not occur in a particular installation. If this equipment does cause harmful interference to radio or television reception, which can be determined by turning the equipment off and on, the user is encouraged to try to correct the interference by one or more of the following measures:

- Reorient or relocate the receiving antenna.
- Increase the separation between the equipment and receiver.
- Connect the equipment into an outlet on a circuit different from that to which the receiver is connected.
- Consult the dealer or an experienced radio/TV technician for help.
- In order to maintain compliance with FCC regulations, shielded cables must be used with this equipment. Operation with non-approved equipment or unshielded cables is likely to result in interference to radio and TV reception. The user is cautioned that changes and modifications made to the equipment without the approval of manufacturer could void the user's authority to operate this equipment.

FCC ID: P2E01TPMS2

This device complies with Part 15 of the FCC Rules. Operation is subject to the following two conditions:

- (1) This device may not cause harmful interference, and
- (2) This device must accept any interference received, including interference that may cause undesired operation.