



15370 Barranca Parkway  
Irvine, CA 92618-2215  
USA



# multiCLASS

MODELS: RMK40 / RMPK40

## INSTALLATION GUIDE

6410-901, REV A.1

AUGUST 18, 2009

© 2009 HID Global Corporation. All rights reserved.

## Overview

This multiCLASS reader is a combination iCLASS Keypad, HID Prox and Magstripe reader which provides secure PIV compatibility. Flexibility is at your fingertips, use this reader simultaneously for magnetic stripe, HID Prox and high frequency smart cards.

For Wiring instructions and Specifications, see the iCLASS Keypad Installation Guide (P/N 6404-901).

## Specifications

PRODUCT PRODUCTO PRODUIT PRODOTO PRODUKT PRODOTTO 製品 产品 제품 ИЗДЕЛИЕ	BASE PART NUMBER NÚMERO DE COMPONENTE BASE RÉFÉRENCE DE BASE NÚMERO DAS PEÇAS BÁSICAS HAUPTTEILENUMMER NUMERO PARTE DI BASE 製品 基本部品番号 产品 基本部件编号 제품 기본부품 번호 ИЗДЕЛИЕ БАЗОВЫЙ НОМЕР ИЗДЕЛИЯ	INPUT VOLTAGE (VDC) TENSIÓN DE ENTRADA (VCC) TENSION D'ALIMENTATION (Vcc) VOLTAGEM DE ENTRADA (VCC) EINGANGSSPANNUNG (VDC) TENSIONE IN INGRESSO (V c.c.) 入力電圧(VDC) 输入电压 (VDC) 입력 전압(VDC) НАПРЯЖЕНИЕ ПИТАНИЯ (В постоянного тока)	CURRENT CORRIENTE COURANT CORRENTE STROMSTÄRKE CORRENTE 電流 电流 전류 ТОК		OPERATING TEMPERATURE TEMPERATURA DE FUNCIONAMIENTO TEMPÉRATURE DE FONCTIONNEMENT TEMPERATURA OPERACIONAL BETRIEBSTEMPERATUR TEMPERATURA D'ESERCIZIO 稼働温度 操作温度 작동 온도 РАБОЧАЯ ТЕМПЕРАТУРА	CABLE LENGTH LONG. DE CABLE LONGUEUR DE CÂBLE COMPIMENTO DO CABO LUNGHEZZA CAVO ケーブル長 电缆长度 케이블 길이 ДЛИНА КАБЕЛЯ	UL REF NUMBER NÚMERO DE REFERENCIA UL RÉF. UL NÚMERO DE REFERÊNCIA UL UL-REFERENZNUMMER NUMERO DI RIFERIMENTO UL UL 参照番号 UL 参考编号 UL 참조 번호 Справочный номер в UL
			AVG	PEAK			
RMK40	6230	5-16 VDC	85 mA	120 mA	-30° - 150°F (-35° - 65° C)	Wiegand = 500 ft - 22 AWG (152.4 m) 300 ft - 24 AWG (91.44 m)	RMPK40Cx <sub>1</sub> x <sub>2</sub> N
RMPK40	6236		** 85 mA	169 mA			

### UL Reference Number Deciphering

x<sub>1</sub> Reader Colors: K = Black, G = Gray

x<sub>2</sub> multiCLASS Proximity: N = HID/AWID Prox

# 1 Head Track Adjustments

For a credential with a different track position, change the head track position on the Magnetic Stripe reader.

1. Snap out the head/gimbal assembly.
2. Rotate the assembly 180 degrees.
3. Re-install the assembly into the reader case.

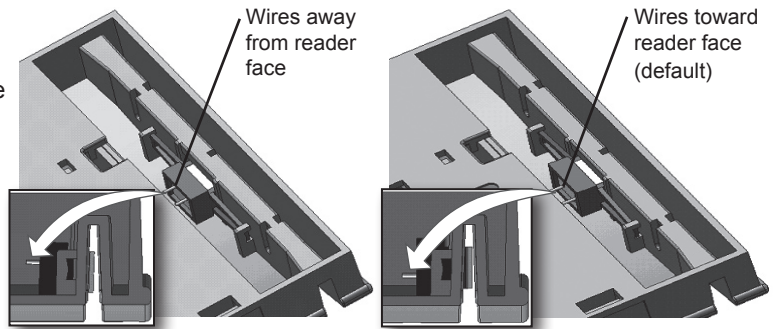

# 2 Mounting

Junction box not included.  
 Caja para conexiones no incluida.  
 Boîtier de jonction non inclus.  
 Caixa de junção não incluída.  
 Anschlusskasten nicht mit inbegriffen.  
 Scatola di raccordo non inclusa.  
 不包括接线盒。  
 接続ボックスは含まれていません。  
 연결 박스는 제품에 포함되지 않습니다.  
 Соединительная коробка не прилагается

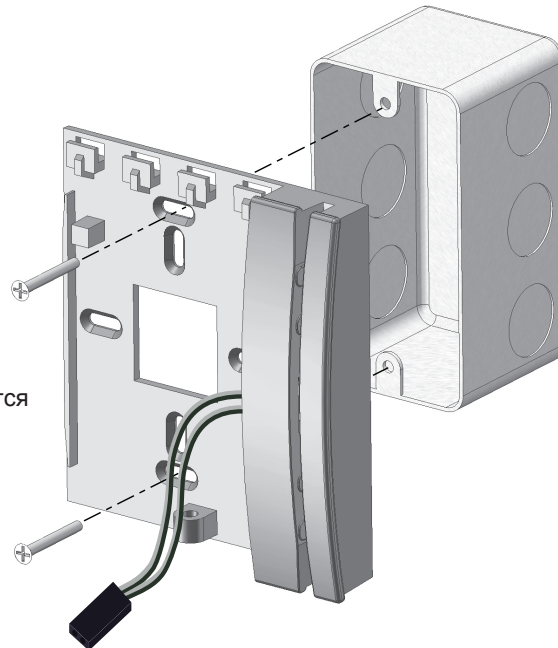

### 3 Wiring

Attach wire (see step 2) from the magnetic stripe reader to the iCLASS Keypad reader connector.

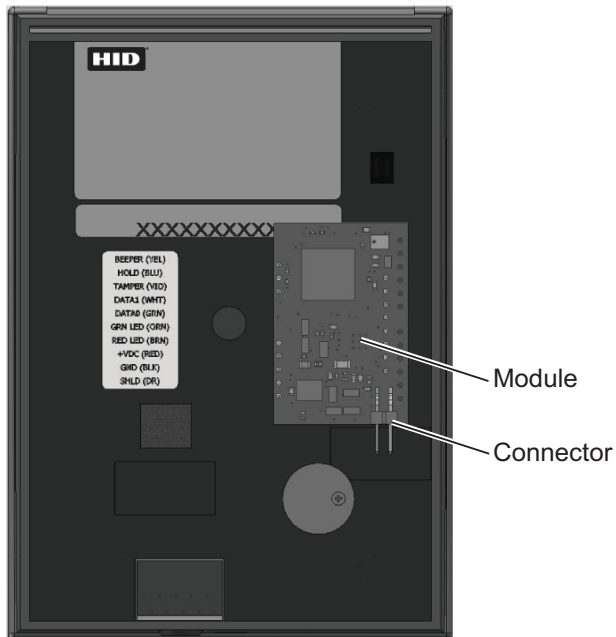

### 4 Install Reader to Backplate



## UL

Connect only to a Listed Access Control / Burglary power-limited power supply. These readers are intended to be used with listed (UL294) control equipment.

Only the Wiegand communication protocol has been investigated by UL.

## FCC / Canada Radio Certification

These devices comply with part 15 of the FCC rules.

Changes or modifications not expressly approved by the party responsible for compliance could void the user's authority to operate the equipment.

Operation is subject to the following two conditions: (1) This device may not cause harmful interference, and (2) This device must accept any interference received, including interference that may cause undesired operation. Changes or modifications not expressly approved by the party responsible for compliance could void the user's authority to operate the equipment.

Le fonctionnement est soumis aux deux conditions suivantes : (1) Ce dispositif ne peut pas causer de perturbations nuisibles et (2) ce dispositif doit accepter toute perturbation quelconque qu'il reçoit, y compris des perturbations susceptibles de provoquer un fonctionnement indésirable. Les changements ou modifications n'ayant pas été expressément approuvés par la partie responsable de la conformité peuvent faire perdre à l'utilisateur l'autorisation de faire fonctionner le matériel.

## CE Marking

HID Global hereby declares that these proximity readers are in compliance with the essential requirements and other relevant provisions of Directive 1999/5/EC.

Por el presente, HID Global declara que estos lectores de proximidad cumplen con los requisitos esenciales y otras disposiciones relevantes de la Directiva 1999/5/EC.

HID Global déclare par la présente que ces lecteurs à proximité sont conformes aux exigences essentielles et aux autres stipulations pertinentes de la Directive 1999/5/CE.

A HID Global, por meio deste, declara que estes leitores de proximidade estão em conformidade com as exigências essenciais e outras condições da diretiva 1999/5/CE.

HID Global bestätigt hiermit, dass die Leser die wesentlichen Anforderungen und anderen relevanten Bestimmungen der Richtlinie 1999/5/EG erfüllen.

HID Global dichiara che i lettori di prossimità sono conformi ai requisiti essenziali e ad altre misure rilevanti come previsto dalla Direttiva europea 1999/5/EC.

Download copies of the R&TTE Declaration of Conformity (DoC) at <http://certifications.hidglobal.com>.



**ACCESS** experience.

[hidglobal.com](http://hidglobal.com)

© 2009 HID Global Corporation. All rights reserved.

6410-901 Rev A.1

Patent Pending

Check reader label for current regulatory approvals.

### HID Global North America

15370 Barranca Parkway  
Irvine, CA 92618  
USA

Phone: 800 237 7769  
Support: 866 607 7339  
Fax: 949 732 2120  
Email: [tech@hidglobal.com](mailto:tech@hidglobal.com)

### Asia Pacific

19/F 625 King's Road  
NorthPoint, Island East  
Hong Kong

Phone: 852 3160 9800  
Support: 852 3160 9833  
Fax: 852 3160 4809  
Email: [asiasupport@hidglobal.com](mailto:asiasupport@hidglobal.com)

### Europe, Middle East & Africa

Phoenix Road  
Haverhill, Suffolk CB9 7AE  
England

Phone: +44 1440 714 850  
Support: +44 1440 711 822  
Fax: +44 1440 714 840  
Email: [eusupport@hidglobal.com](mailto:eusupport@hidglobal.com)

HID, HID Global, and iCLASS are the trademarks or registered trademarks of HID Global Corporation in the U.S. and other countries.

An ASSA ABLOY Group brand

**ASSA ABLOY**