

USER MANUAL

Apx B



DRAFT

System 400

Wireless Audio System

ENGINEERING WORKING DOCUMENT
NOT
RELEASED FOR PRODUCTION
[Signature] 9/14/98

Operating Instructions

(For Full-Duplex and Half-Duplex Operations)

6675 Mesa Ridge Road, San Diego, CA 92121 USA
Phone: 1-800-848-4468 Fax: (619) 552-0172



HM ELECTRONICS, INC.

Table of Contents

I.	GENERAL	1
II.	EQUIPMENT IDENTIFICATION	1
	A. Main Components	1
	B. Controls, Switches, Connectors and Indicator Lights	2
	1. Base Station	2
	2. COMMUNICATOR®	3
	3. Battery Charger	3
III.	EQUIPMENT CARE AND USE	4
	A. Using the Batteries and Battery Charger	4
	B. Wearing the COMMUNICATOR®	6
	C. Using the COMMUNICATOR®	6
	D. HOW TO and HOW NOT TO handle the Headset Cable and Connector	8
	E. How to Clean the COMMUNICATOR®	8
IV.	NORMAL SYSTEM 400 OPERATION	9
	A. Single Drive-Thru Lane, Full-Duplex Operation	9
	B. Single Drive-Thru Lane, Half-Duplex Operation	9
	C. Dual Drive-Thru, Full-Duplex Operation	10
	D. Dual Drive-Thru, Half-Duplex Operation	10
	E. Message Repeater Operation	10
	F. Speed-Team Operation	11
	G. Remote Display Operation	11
V.	IN CASE OF PROBLEMS	12
VI.	SPECIFICATIONS	15
VII.	ACCESSORIES AND OPTIONAL EQUIPMENT	16
VIII.	FCC NOTICE	16

List of Figures

Figure	Title	Page
1	System 400 Base Station	1
2	AC420 Battery Charger	1
3	COM420 COMMUNICATOR®	1
4	Base station features	2
5	Communicator controls, connector and indicator light	3
6	Installing the battery	4
7	Opening the battery compartment	4
8	A properly installed battery in the battery charger	5
9	Plug the earpiece/microphone cable into the cable receptacle	6
10	Insert belt through belt loop on back of Communicator pouch	6
11	Correct wearing of Communicator headset	7
12	Communicator pushbutton controls	7
13	Base station circuit boards	14

I. GENERAL

The System 400 is a wireless audio system primarily for use at quick-service restaurants.

II. EQUIPMENT IDENTIFICATION

A. Main Components

- System 400 Base Station
- AC420 Battery Charger
- COM420 COMMUNICATOR®
(includes belt and pouch plus one spare battery)

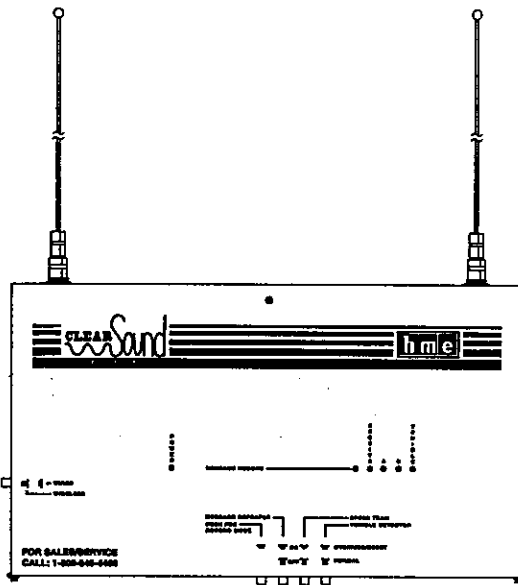

Figure 1.
System 400 Base Station

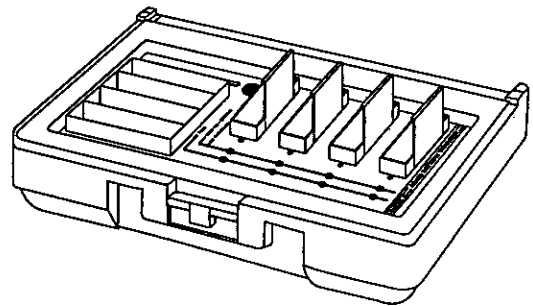

Figure 2.
AC420 Battery Charger

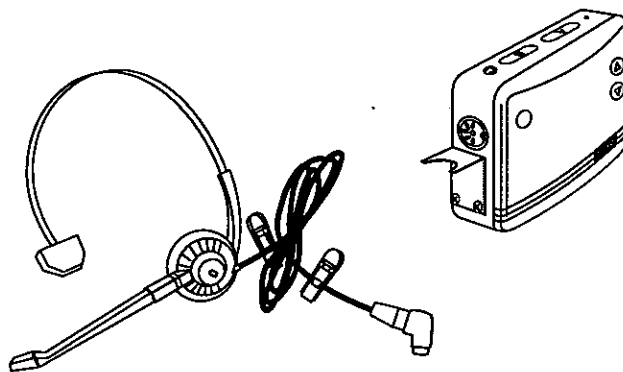

Figure 3.
COM420 COMMUNICATOR®

B. Controls, Switches, Connectors and Indicator Lights

1. Base Station

Front –

System indicator lights

- **POWER light** is on when the base station has power.
- **MESSAGE RECORD light** is on when the base station is ready to record a message for the message repeater, and blinking while a message is being recorded. The MESSAGE REPEATER button must be IN.
- **RECEIVE light** is used only for troubleshooting, but is also on during channel-A and channel-B transmissions.
- **“A” light** is on during channel-A transmission.
- **“B” light** is on during channel-B transmission.
- **VEHICLE light** is on when a vehicle is present in the drive-thru lane or when the system is in vehicle-detect override.

Bottom –

- **PUSH FOR RECORD MODE button**; must be pushed IN and released to prepare the base station to record a message for the message repeater.
- **MESSAGE REPEATER button**; must be IN to use the message repeater, OUT when the message repeater is not being used.
- **SPEED TEAM button**; must be IN for speed-team operation, OUT for normal drive-thru operation
- **VEHICLE DETECTOR button**; to override a vehicle detector, push and leave IN: to reset vehicle detector, push IN and leave In for 5 seconds, then push again and leave OUT for normal vehicle detection.

Left Side –

- **WIRED/WIRELESS button**; must be OUT when using the wireless System 400, IN when using a wired backup system.

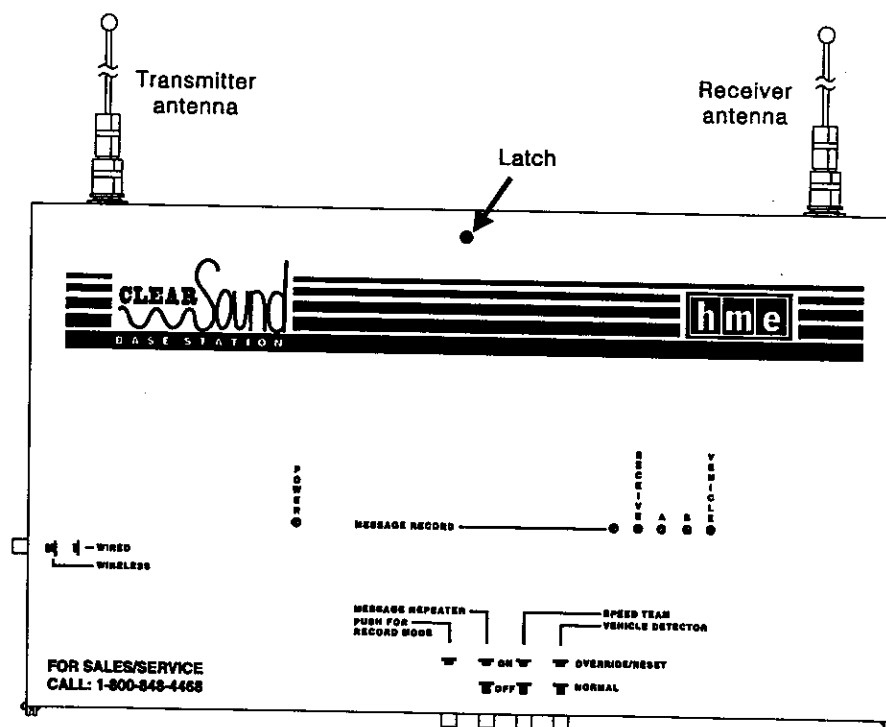

Figure 4. Base station features

2. COMMUNICATOR®

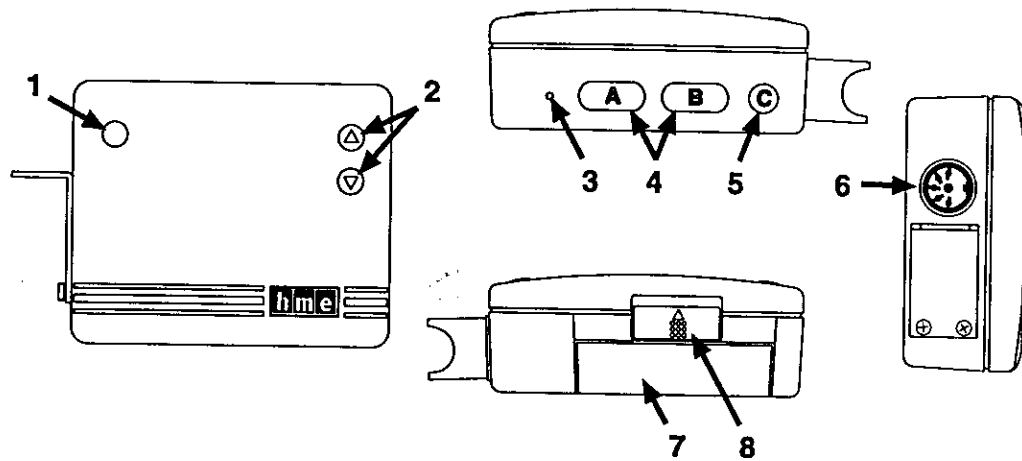

Figure 5. Communicator controls, connector and indicator light

- 1 – **OFF/ON button:** turns Communicator on and off.
- 2 – **Volume control buttons:** adjust listening level in earpiece.
- 3 – **Power-on light:** lights when power goes on, and remains lit until battery needs replacing or Communicator is turned off. The power-on light blinks when transmitting on "A" or "B" channel.
- 4 – **Buttons A & B:** Button "A" allows two-way communication when pushed and held; when it is released, the user can listen only. Button "B" must be pushed and held to talk, and released to listen. The two buttons are in convenient positions whether Communicator is worn on left or right hip.
- 5 – **Button C:** switches from one base station to another in systems with two base stations.
- 6 – **5-pin DIN receptacle:** receptacle for earpiece/microphone cable connector.
- 7 – **Battery:** provides power for the wireless belt-pac Communicator.
- 8 – **Battery release latch:** slides to release battery for removal, and snaps in place when a battery is inserted to secure battery in Communicator.

3. Battery Charger (See Figure 8 on page 5.)

Top –

Red lights indicate that batteries below the lights are charging.

Green lights indicate that batteries below the lights are fully charged.

Back –

AC adapter connector is for connecting AC adapter cable to battery charger.

III. NORMAL OPERATION AND USE

A. Using the Batteries and Battery Charger

Before operating your COMMUNICATOR®, be certain you have a fully charged NiCd battery. Place it in the Communicator as instructed below.

1. Installing and removing Communicator batteries

- Install a fully charged NiCd battery in the battery compartment with the arrow on the battery pointing out as shown in Figure 6. Slide it into the tracks on both sides of the compartment until its catch clicks securely in place.

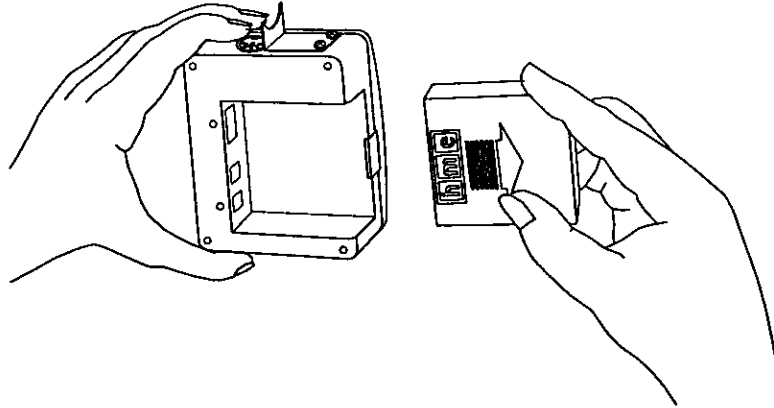

Figure 6. Installing the battery

- To remove the battery from a Communicator, slide the battery latch open and push the battery in the direction of the large arrow on the battery as shown in Figure 7.

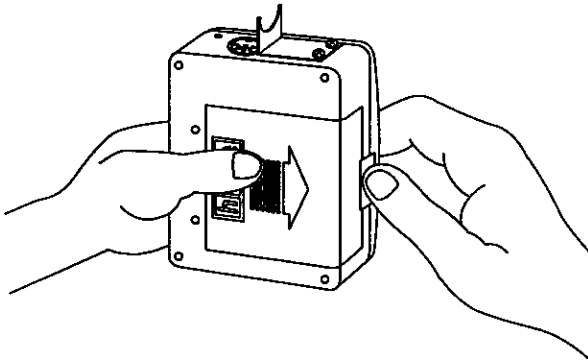

Figure 7. Opening the battery compartment

2. When to replace batteries

When a good battery is in the COMMUNICATOR® and the power is on, the red light on top of the unit will be lit. This light only indicates the power is on. It does not indicate how much power is left in the battery. As a battery weakens during routine use, you will hear a repeating beep in the earpiece, indicating the battery needs to be replaced. Typical battery life with normal use is 8 to 10 hours.

CAUTION: Turn Communicator OFF before removing batteries !

To prevent damage, turn the Communicator OFF before removing or installing batteries.

3. Charging NiCd batteries with the battery charger

Your battery charger should be used in a low-traffic area, away from dust or splashing water and grease. If your battery charger is not already plugged in, remove the AC adapter from its box and plug its cord into the connector on the back of the battery charger case. Plug the adapter into an AC electrical outlet.

Place up to four batteries in the charger to charge at the same time, as shown in Figure 8. As each battery is placed in the charger, the red CHARGING light on the panel adjacent to the battery will light, indicating it is charging. If the red light flashes when the battery is installed, the battery may be defective. If this happens, remove the battery and re-insert it in another compartment. If the red light flashes again, the battery is defective and needs to be replaced. When a battery is fully charged, the green READY light on the panel adjacent to it will light. **(approximately 4 hours)** It can then be placed back into a Communicator.

CAUTION: Do not remove batteries from the charger until the green READY light is lit or the red light is flashing, or the charger will reset and the charge cycle will begin again.

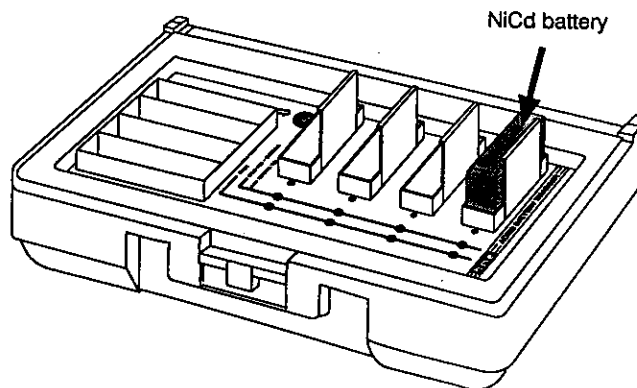

Figure 8.

**A properly installed battery
in the battery charger**

B. Wearing the COMMUNICATOR®

Plug the headset-cable connector into the receptacle on the Communicator as shown in Figure 9. The connector is keyed so it can only be inserted in the correct position, with the cord extending downward. Loosen the snap on the cord protection flap and resnap it with the flap over the cord.

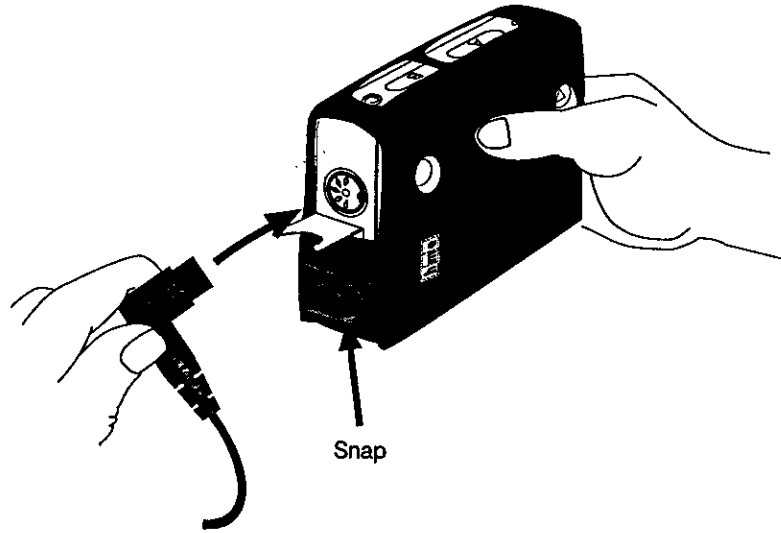

Figure 9. Plug the headset-cable connector into the cable receptacle

Insert the Communicator belt through the loop on back of the Communicator pouch as shown in Figure 10, and fasten the belt securely around your waist. The Communicator can be worn over either your right or left hip.

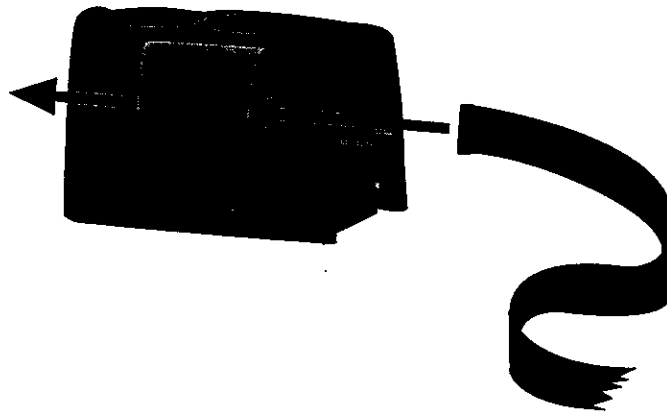

Figure 10. Insert belt through belt loop on back of Communicator pouch

Put the headset on your head and clip one of the clothing clips to your collar as shown in Figure 11. Clip the other clothing clip to the back of your shirt, above your waist. Position the microphone approximately 2 inches (50.8 mm) from your mouth.



Figure 11.
Correct wearing of the Communicator headset

C. Using the COMMUNICATOR®

Turn the Communicator on by pressing the ON/OFF button. Be certain the red power light goes on when the Communicator is turned on.

If the power light does not go on, the battery (or batteries) must be changed.

Push and hold either the "A" or "B" button on top of the Communicator and speak into the microphone. You should hear your own voice in the earpiece. Adjust the volume control on the Communicator to a comfortable listening level. When you have finished talking, release the button immediately.

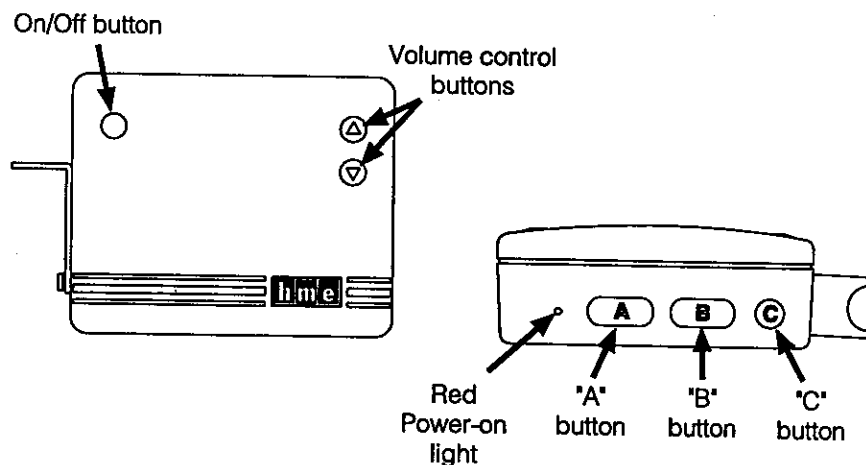

Figure 12. Communicator pushbutton controls

NOTE: If other than an HME earpiece/microphone or headset will be used with the Communicator, be certain it has an electret microphone with an impedance of 1000-2000 ohms.

D. HOW TO and HOW NOT TO handle the Headset Cable and Connector

ALWAYS	NEVER
<p>Align the connector key and pins with key and holes in the receptacle when plugging the headset into the Communicator.</p> <p>Fasten cable to pouch with strain relief strap.</p> <p>Clip the cable to your clothing with the clothing clips.</p> <p>Grasp the connector to plug in or unplug the headset.</p> <p>Use both hands to remove the headset from your head.</p> <p>Use both hands to adjust the microphone position.</p> <p>Handle the headset cable with care.</p> <p>Carry and hang the headset by its metal headband.</p>	<p>Twist headset connector into Communicator receptacle.</p> <p>Allow cable to be stressed at connector.</p> <p>Allow cable to hang freely.</p> <p>Grasp and pull cable to unplug headset.</p> <p>Remove headset with only one hand.</p> <p>Aadjust microphone position with only one hand.</p> <p>Pull, twist, bend or knot the headset cable.</p> <p>Carry or hang the headset by its cable.</p>

E. How to Clean the COMMUNICATOR®

The following cleaning procedure is recommended at least once each month.

- Remove the Communicator from the pouch.
- Remove the battery from the Communicator.
- Wash the belt and pouch in a washing machine with normal laundry detergent. Dry them in a dryer or hang them up to dry.
- Clean the Communicator with a damp sponge. Wet the sponge and wring it out so it is damp, not dripping wet. Spray household cleaner on the sponge (NOT DIRECTLY ON THE EQUIPMENT). Clean the Communicator with the sponge, and dry it throughly.
- Clean the metal battery contacts on the battery with alcohol on a cotton swab. Wet the tip of the swab with alcohol and squeeze the excess alcohol from it. Wipe each contact with the swab, and be certain all the contacts are dry before installing the batteries.
- Place the battery back in the Communicator, and place the Communicator back in the pouch, fastening the strap securely over it.
- Clean the headset and cable with a damp sponge sprayed with household cleaner. The foam muff on the headset earpiece is easily replaced for sanitary purposes. To order extra foam muffs, call your local HME sales representative.

IV. OPERATION

In single or dual drive-thru operations, COMMUNICATOR® button "A" is for communication with the customer, and button "B" is for communication with other crew members wearing Communicators. In dual drive-thru operations, the Communicator button "C" is used to switch between Lanes 1 and 2. Button "C" has no function in single drive-thru operations.

A. Single Drive-Thru Lane, Full-Duplex Operation

ACTION	RESULT
<p>If you are using the Communicator latching feature: Press and release button "A" to latch communication channel open for speaking and listening to customer. The channel will unlatch, ending communication with the customer, if;</p> <ol style="list-style-type: none"> 1. you press and release button "A" again, or 2. you press button "B," or 3. you turn off the Communicator, or 4. the customer drives away, or 5. after 10 minutes of continuous latched communication. <p>If you are not using the Communicator latching feature: Press and hold button "A" while speaking and listening to customer. Release when transaction is completed.</p>	<p>Customer hears your voice and you hear customer's voice (two-way conversation). Operation is "hands-free" until the customer pulls away. Everyone wearing a Communicator hears the communication.</p>
<p>While customer is speaking, press the "+" or "-" arrow to adjust volume level.</p>	<p>Beep tones of increasing/decreasing frequency are heard in headset as volume level increases/decreases. Customer's voice becomes louder or softer.</p>
<p>Press and hold button "B" to speak to other crew members wearing Communicators. Release to listen.</p>	<p>Other personnel wearing Communicators hear your voice in their headsets.</p>

B. Single Drive-Thru Lane, Half-Duplex Operation

ACTION	RESULT
<p>Press and hold button "A" while speaking to customer.</p>	<p>Customer hears your voice. Everyone wearing a Communicator hears the communication.</p>
<p>Release button "A" and listen to customer.</p>	<p>Customer's voice is heard in headsets of everyone wearing a Communicator.</p>
<p>While customer is speaking, press the "+" or "-" arrow to adjust volume level.</p>	<p>Beep tones of increasing/decreasing frequency are heard in headset as volume level increases/decreases. Customer's voice becomes louder or softer.</p>
<p>Press and hold button "B" to speak to other crew members wearing Communicators. Release to listen.</p>	<p>Other personnel wearing Communicators hear your voice in their headsets.</p>

C. Dual Drive-Thru, Full-Duplex Operation

ACTION	RESULT
<p>If you are using the COMMUNICATOR® latching feature: Press and release button "A" to latch communication channel open for speaking and listening to customer in Lane 1 or 2. The channel will unlatch if:</p> <ol style="list-style-type: none"> 1. you press and release button "A" again, or 2. you press button "B", or 3. you press button "C", or 4. you turn off the Communicator, or 5. the customer drives away, or 6. after 10 minutes of continuous communication. <p>If you are not using the Communicator latching feature: Press and hold button "A" while speaking and listening to a customer in Lane 1 or 2. Release when the transaction is completed.</p>	<p>Customer hears your voice and you hear customer's voice (two-way conversation). Operation is "hands-free" until the customer pulls away. Everyone wearing a Communicator hears the communication.</p> <p>NOTE: When transmitting in Lane 1 operation, the Communicator power light will blink rapidly. When transmitting in Lane 2 operation, the Communicator power light will blink rapidly 4 times, then pause and repeat. Refer to page 3, section 2 for further explanation.</p> <p>Lanes 1 and 2 have different sounding vehicle-present tones.</p>
While customer is speaking, press the "+" or "-" arrow to adjust volume level.	Beep tones of increasing/decreasing frequency are heard in headset as volume level increases/ decreases. Customer's voice becomes louder or softer.
Press button "C" to switch to the other lane.	You can begin speaking and listening to the customer in the other lane.
Press and hold button "B" to speak to other crew members wearing Communicators. Release to listen.	Other personnel wearing Communicators hear your voice in their headsets.

D. Dual Drive-Thru, Half-Duplex Operation

ACTION	RESULT
Press and hold button "A" while speaking to customer in Lane 1 or 2.	Customer hears your voice. Everyone wearing Communicators hears the communication.
Release button and listen to customer.	Customer's voice is heard in headsets of everyone wearing Communicators.
While customer is speaking, press the "+" or "-" arrow to adjust volume level.	Beep tones of increasing/decreasing frequency are heard in headset as volume level increases/ decreases. Customer's voice becomes louder or softer.
Press button "C" to switch to the other lane.	You can begin speaking and listening to the customer in the other lane.
Press and hold button "B" to speak to other crew members wearing Communicators. Release to listen.	Other personnel wearing Communicators hear your voice in their headsets.

E. Message Repeater Operation

ACTION	RESULT
Press the MESSAGE REPEATER button IN on the System 400 base station and do the following.	None
Press and release the red RECORD MODE button on the System 400 base station.	The MESSAGE RECORD light on the System 400 base station will come on.
Press and hold button "B" on the Communicator and talk into the headset microphone to record a message (16 second maximum).	The MESSAGE RECORD light on the System 400 base station will begin blinking.
Release button "B."	The record function will stop and the light will go off.

After a new message has been recorded, or after the base station has lost and regained power, the message will always be heard in the Communicator headset the first three times it plays.

F. Speed-Team Operation

Speed-team operation is used during high-volume times. An order taker wearing a belt-pac relays orders from outside into the store using the "B" channel on the COMMUNICATOR®. Placing the SPEED TEAM switch in the ON (in) position will disable the speaker and microphone in the speaker post or menu board, and will also disable the vehicle tone and alert tone from the timer.

G. Remote Display Operation

One or more R30 Remote Displays may be used with your System 400. Each remote display was set up by the installer to show the amount of time the current car has been at the menu board, speaker post or service window. A remote display shows the time for one location only. It begins counting when the car arrives and stops when the car leaves. The remote displays will only display time. They will not store or record information.

V. IN CASE OF PROBLEMS (Refer to the circuit board illustration on page 14)

TROUBLESHOOTING CHECKLIST		
Problem	Probable Cause	Solution
No sound in headset when you press COMMUNICATOR® button "A" and speak into headset microphone.	Power is off at base station.	Check circuit breaker for building.
	Power supply in base station is not working.	Check power supply indicator lights on base station. If any light is not lit, be certain AC power adapter is plugged into AC electrical outlet, and connected to J2 connector on audio circuit board in base station.
	Communicator not turned on.	Turn Communicator on by pushing ON/OFF button for 1 second. Be certain light goes on.
	Volume not set correctly.	Push volume-control buttons to adjust volume.
	Headset connector not plugged firmly into Communicator.	Plug headset connector firmly into Communicator receptacle.
	Headset defective.	Replace with another headset.
	Low or dead battery.	Check ON/POWER light. If not lit, replace battery.
	Communicator failed.	Use another Communicator. Call HME. *
Communicator channel "A" or "B" functions not working.	Communicator not turned ON.	Turn Communicator on.
	Dead or weak battery.	Replace battery.
	Communicator or base station failure. Channel "A" or "B" light and RECEIVE light on base station do not light when Communicator button "A" or "B" is pressed.	Use another Communicator. Call HME. *
"C" button does not switch between channels in a dual-lane drive-thru.	Switch setting on Communicator incorrect.	Check S1 switch. Switch #5 should be ON.
Outbound sound too low.	Outbound volume set too low for environment.	Turn outside speaker volume control (R128 in base station) clockwise with small standard (slotted) screwdriver until level is satisfactory.
No outbound sound; customer cannot hear anything.	System may be set for speed-team operation.	Be certain SPEED TEAM button on base station is out (OFF).
	Loose wires on base station circuit board.	Check speaker wire connections on switcher circuit board.
	Defective speaker or base station.	Call HME. *

* For assistance, call HME at 1-800-848-4468, or Fax 619-552-0172.

Problem	Probable Cause	Solution
No inbound sound from customer (in half-duplex operation)	Latching feature may be on.	Check S1 switch on Communicator. Switch #4 should be OFF.
	System may be set for speed-team operation.	Be certain SPEED TEAM button on base station is out (OFF).
	Base station may be set for wrong drive-thru mode (full or half-duplex).	Check S6 switch on base station circuit board. Switch #1 should be ON for full-duplex OFF for half-duplex
Personnel hear static only in headsets.	Transmitter antenna connection on base station is loose.	Tighten transmitter antenna connection. (the antenna on top, left of base station.)
	No power to base station.	Check base station power adapter connections.
	Circuit board defective.	Call HME. *
Personnel hear customer in headsets or ceiling speaker, but cannot hear each other.	Receiver antenna connection on base station is loose.	Tighten receiver antenna connection. (the antenna on top, right of base station.)
	Status lights are not lit. Circuit board is defective.	Call HME. *
	Defective COMMUNICATOR® or headset.	Call HME. *
No tone or sound in headset or ceiling speaker when vehicle drives into drive-thru lane.	Power interruption has caused unbalanced detecting circuit.	When no vehicle is in the drive-thru lane, press vehicle detector override switch on base station to RESET position, then back to NORMAL position.
	System may be set for speed-team operation. See page 7, paragraph F.	Be certain SPEED TEAM button on base station is out (OFF).
	Connector may be loose.	Check all connectors. Call HME. *
Personnel cannot hear outside customers in headset or ceiling speaker.	Loose wires on base station circuit board connector.	Be certain wires are securely connected in base station.
	System may be set for speed-team operation.	Be certain SPEED TEAM button on base station is out (OFF).
	Outside speaker or audio circuit board has failed.	Call HME. *
Communicator has intermittent sound.	Low battery.	Replace battery.
	Defective headset cable.	Use another headset. Call HME. *
Headset does not become silent after customer has driven away.	VERRIDE/RESET, NORMAL switch on base station is in the OVERRIDE/RESET position.	Place switch in the NORMAL position.
	Vehicle detector is locked up.	Press OVERRIDE/RESET switch twice.
Battery charger not working.	Charger not plugged in.	Plug in battery charger. If still not working, call HME. *
Can not record message.	Message repeater not turned on.	Turn message repeater on.
Message will not play.		

* For assistance, call HME at 1-800-848-4468, or Fax 619-552-0172.

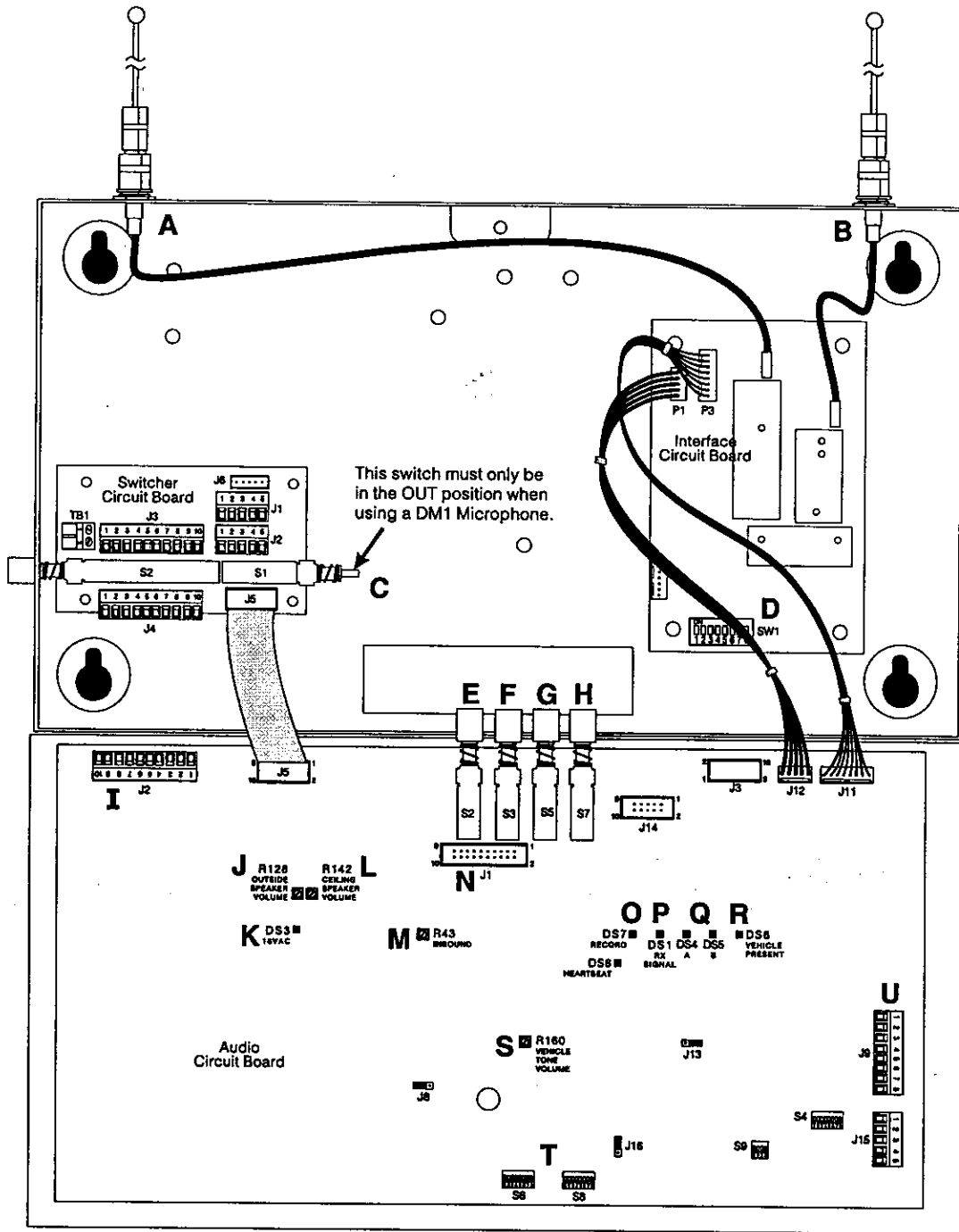

Figure 13.

Base station circuit boards

A - Transmitter antenna connector	L - Ceiling speaker volume control - R142
B - Receiver antenna connector	M - Inbound volume control - R43
C - DM1 select switch	N - Automatic test equipment (ATE) connector - J1
D - Frequency select switch - SW1	O - Message record LED - DS7
E - Record message switch - S2	P - Receiver LED - DS1
F - Message repeater ON/OFF switch - S3	Q - Channel A & B LEDs - DS4, DS5
G - Speed team switch - S5	R - Vehicle present LED - DS6
H - Vehicle detector override switch - S7	S - Vehicle present tone volume control - R160
I - Power and ceiling speaker connector - J2	T - System configuration switches - S6, S8
J - Outside speaker volume control - R128	U - Base-to-base connector (for dual drive-thru operations) - J9
K - Power supply LEDs, 16VAC - DS3	

VI. SPECIFICATIONS

Base Station

1.	Voltage input	16VAC \pm 2.5V
2.	AC current input	350mA nominal, 1.4A maximum
3.	Audio distortion	<5% maximum level
4.	Outside speaker output	3 watts RMS into 8 ohms
5.	Ceiling speaker power	3 watts RMS into 8 ohms
6.	Message repeater	Message duration - 16 seconds
7.	Controls/Switches	2-position vehicle detector switch (Normal - Override/Reset) 2-position "Speed Team" ON/OFF switch 2-position "Message Repeater" ON/OFF switch 1-position "Record" switch 4-position RS485 bias/term switch Outside speaker volume control Outside speaker Hi-Lo volume jumper Vehicle present tone level control "A" sidetone "B" sidetone Inbound volume control VAA level control Ceiling speaker volume control Vehicle present tone volume control (3) 8-position DIP switches 4-position frequency select switch Wireless/wired system select switch Horn speaker/DM1 select switch
8.	TX/RX Frequency	FCC Part 90
9.	Dimensions	8.2"H x 14.2"W x 3.5"D (208mm x 361mm x 89mm)
10.	Weight	5.5 lbs (2.49kg) maximum

Battery Charger

1.	Voltage input:	16.5VAC
2.	AC current input:	1.2A maximum at 16.5VAC
3.	Number of charge ports:	4
4.	Charge time:	4-8 hours
5.	Dimensions:	8"L x 12"W x 3.5"D (203mm x 305mm x 89mm)
6.	Weight:	1.5 lb (0.69 kg) - not including AC adapter
7.	Indicators:	Battery-charging (red) LEDs, 4 ea Battery-ready (green) LEDs, 4 ea

COMMUNICATOR®

1.	Battery (NiCd)	8-10 hours
2.	RF Frequency	Receive — FCC Part 90 Transmit — FCC Part 90
3.	Dimensions	3 $\frac{3}{8}$ "H x 4 $\frac{1}{8}$ "W x 1 $\frac{1}{2}$ "D (86mm x 114mm x 38mm)
4.	Weight	11 ounces (3.12kg) — including battery
5.	Controls	Buttons "A," "B" and "C" Power/Volume control
6.	Indicator	Red LED Solid when receiving only. Blinking when transmitter is activated.
7.	Connector	5-pin DIN

VII. ACCESSORIES AND OPTIONAL EQUIPMENT

The following optional equipment is available for use with your System 400.
To order any of these products, call the HME Sales Department at (619) 535-6060.

Equipment	Model Number
COMMUNICATOR®	COM420
Battery, Spare for COM420	
Headset Earmuff	
Earpiece/Microphone	HS4
Ultrasonic Vehicle Detector	DU2/DU3
Vehicle Detector Board	VDB101
Vehicle Detector Loop (underground)	VDL100
Message Repeater	MR100A
Remote Display	R30
Ceiling Speaker	MM100
Variable, Low-Profile Speaker	MM2500

VIII. FCC NOTICE

HME wireless radio frequency systems are type-accepted in the United States under Part 90 of the Federal Communications Commission (FCC) Code of Federal Regulations, and type-approved in Canada by Industry and Science Canada. Because licensing depends on the system's application, it is the user's responsibility to apply for a license from the FCC in the U.S. and its possessions, or from Industry and Science Canada in Canada and its territories. Licensing requirements vary from country to country. Contact your local licensing agency for specific requirements.

This device complies with Part 15 of the FCC rules. Operation is subject to the following two conditions: (1) This device may not cause harmful interference, and (2) This device must accept any interference received, including interference that may cause undesired operation.

NOTE: This equipment has been tested and found to comply with the limits for a Class A digital device, pursuant to Part 15 of the FCC rules. These limits are designed to provide reasonable protection against harmful interference when the equipment is operated in a commercial environment. This equipment generates, uses and can radiate radio frequency energy and, if not installed and used in accordance with the instruction manual, may cause harmful interference to radio communication. Operation of this equipment in a residential area is likely to cause harmful interference, in which case the user will be required to correct the interference at his own expense.

Changes or modifications not expressly approved by HM Electronics, Inc. could void the users authority to operate this equipment.