

Replacing the battery

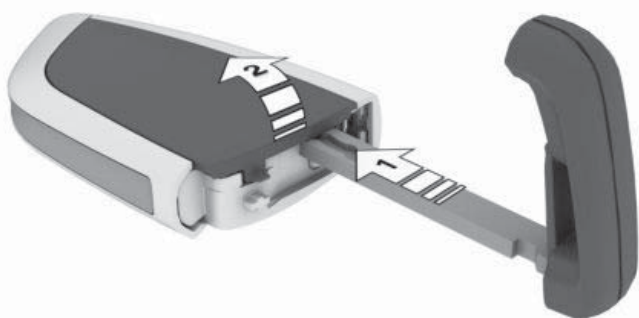

1. Remove the integrated key from the remote control.
2. Lift the cover for the battery compartment, arrow 1.
3. Remove the cover for the battery compartment, arrow 2.
4. Insert a new battery of the same type with the positive side facing upwards.
5. Press the cover back into position.



Hand old batteries into an authorised collecting point, a Service Partner or a qualified specialist workshop.

New remote controls

New remote controls are available from a Service Partner or a qualified specialist workshop.

Loss of remote controls

A lost remote control can be blocked by a Service Partner or a qualified specialist workshop.

Special ID of the remote control

Drive-ready state can also be activated in the following situations:

- ▶ Interference in the radio transmission to the remote control from external sources, for example by radio masts.
- ▶ Flat battery in the remote control.
- ▶ Interference in radio transmission due to mobile radio device in the immediate vicinity of the remote control.

- ▶ Interference in radio transmission due to the charger when charging in the vehicle, for example for mobile devices.

If an attempt is made to start the engine or activate drive-ready state, a Check Control message is displayed.

Activating ready-to-drive function via special ID of the remote control

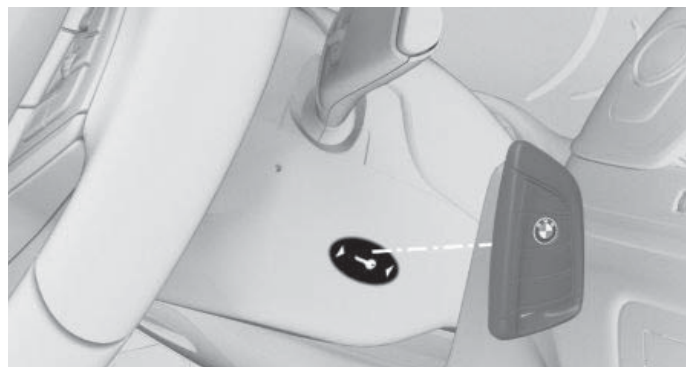

If there is a corresponding Check Control message, hold the remote control with its back against the marking on the steering column. The boot button on the remote control should be at the same level as the marking. Within 10 seconds, press the start/stop button whilst holding the brake pedal pressed.

If the remote control is not detected: change the height of the remote control slightly and repeat the procedure.

BMW display key

General

The delivery specification includes the BMW Display key with an additional mechanical key instead of a standard remote control. When using the BMW Display key, you should also carry the mechanical key with you, e.g. in your wallet or purse.

The BMW Display key supports all functions of the standard remote control, and in addition provides the following functions.

- ▶ Call up status of doors and windows.

- ▷ Call up status of the alarm system.
- ▷ With auxiliary heating: operate auxiliary heating.
Without auxiliary heating: operate independent ventilation.
- ▷ Call up range with the available fuel.
- ▷ Call up service information.

Special ID of the BMW display key

The description for the special ID of the remote control, see page 53, also applies to the BMW display key. However, the locking button should be at the same level as the marking.

Overview

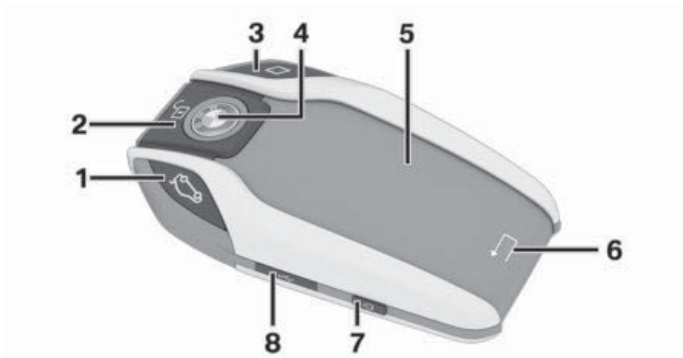

- 1 Opening/closing boot lid
- 2 Unlocking
- 3 Headlight courtesy delay feature
- 4 Locking
- 5 Display
- 6 Back
- 7 Switch display on/off
- 8 Micro-USB charge point

Reception range

Number of available functions of remote control depends on distance to vehicle.

- ▷ In close reception range, all functions of remote control are available.
- ▷ In the extended reception range, the status information can be called up.

With auxiliary heating: auxiliary heating can be operated.

Without auxiliary heating: independent ventilation can be operated.

- ▷ Outside reception range, it is possible to display last status information transmitted from vehicle.

☞ Symbol is shown on the display if one of the buttons is pressed outside the reception range.

Display

Structure

Display is divided into status bar at top, information area and status bar at bottom.

Status bar at top shows following information:

- ▷ Vehicle locked.
- ▷ Vehicle unlocked.
- ▷ Time set in vehicle.
- ▷ Charge status of battery in remote control.

In the information area, the information can be called up and the additional functions carried out.

The status bar at the bottom shows, whether the remote control is within the reception range, see page 54.

- ▷ "Connected": remote control is within the reception range.
- ▷ "Updated": remote control is outside of the reception range. It is displayed when the last data transfer from the vehicle took place.

Controls

If information area contains more than one page, page indicators are displayed under information.

○●○ Indicator for current side is filled in.

Swipe to the left or right to switch between the pages.

If further information can be accessed on a page, tap on the corresponding symbol.

↩ Tap the arrow symbol below the display to return to the higher-level page.

Switching the display off/on

The content of the display is hidden automatically after a brief time to reduce battery power consumption.

Press the button on the left of the remote control to hide the content of the display manually. Overview, see page 54.

Show content on the display:

1. Press button on the left of the remote control.
2. Next, swipe your finger from the bottom to the top to revoke the screen lock.

To increase the battery lifespan, the display can be completely switched off.



1. Press and hold the button on the left of the remote control for more than 4 seconds.
2. Tap on "OK".

Press the button on the left of the remote control to switch the display on.

Operating principle

Depending on the equipment version, there are up to five main menus via which submenus can be accessed.

The following overview shows which main menus provide access to the information and functions.

Menu	Information/function
"Security information"	 Status of the doors Status of the alarm system After alarm triggering: date, time and reason for the alarm triggering
	 Status of the windows Status of the Glass Roof
"Vehicle information"	Maintenance displays of the Condition Based Service CBS, see page 293 Status of the parking lights
"Range information"	Range with the available fuel
"Climate control setting"	With auxiliary heating: operate auxiliary heating, see page 216. Without auxiliary heating: operate independent ventilation, see page 216.

Charging remote control battery

If the charge status of the remote control battery decreases, the display is automatically switched off. Battery must be charged before display can be switched on again. Functional capability of standard buttons is remained until battery is completely flat.





To charge the remote control battery:



- ▶ Place the remote control with the locking button facing upwards into the recess of the wireless charging cradle underneath the centre armrest.
- ▶ Connect remote control to a USB connection using the Micro-USB socket on the left side.

Software information

Proceed as follows to display the information regarding the OpenSource software used, saved in the BMW display key:

1. Menu "Security information"
2. Tap  /  symbol.
3.  /  Tap on the symbol three times.

To cancel the display:

Tap  symbol.

Driver profiles

Principle

Individual settings of several drivers can be saved in the driver profiles and called up at a later point in time.

General

Three profiles are provided, in which personal vehicle settings can be saved. Each remote control is allocated to one of these driver profiles.

When the vehicle is unlocked with a remote control, the allocated driver profile is activated. All the settings saved in the driver profile are applied automatically.

If several drivers each use their own remote control, the vehicle will adapt to their personal settings when it is unlocked. These settings are also resaved if the vehicle is used in the intervening period by someone with a different remote control.

Changes to settings are saved automatically in the currently used driver profile.

If a different driver profile is selected via iDrive, the settings saved there are automatically applied. The new driver profile is allocated to the remote control currently used.

In addition, a guest profile is available that is not allocated to any remote control: "Just drive off (guest)". It can be used for making settings on the vehicle without changing the driver profiles.

Currently used driver profile

The name of the currently used driver profile is displayed when the Control Displays is switched on.

It can be directly jumped into profile management, see page 57, e.g. to select the own driver profile. This way, the personal vehicle settings can be called up, if the vehicle was not unlocked with the own key.

1. "Change driver profile"
2. Select driver profile, see page 57.

As soon as the engine is started or any button pressed, the display selected last is shown on the Control Display.

To cancel the welcome screen via iDrive:

"Start system"

Settings

Settings for the following systems and functions are saved in the currently used driver profile. The extent of settings that can be saved depends on the country and equipment.

- ▶ Unlocking and locking.
- ▶ Light.
- ▶ Air conditioning.
- ▶ Radio.
- ▶ Instrument cluster.
- ▶ Favourites buttons.
- ▶ Volumes, sound.
- ▶ Control Display.
- ▶ Navigation.

Hereby, BMW, declares that this Display Key is in compliance with the essential requirements and other relevant provisions of Directive 1999/5/EC

This device complies with Part 15 of the FCC Rules. Operation is subject to the following two conditions: (1) this device may not cause harmful interference, and (2) this device must accept any interference received, including interference that may cause undesired operation

This device complies with Industry Canada's licence-exempt RSSs. Operation is subject to the following two conditions:

- (1) This device may not cause interference; and
- (2) This device must accept any interference, including interference that may cause undesired operation of the device.

RF exposure warning:

The equipment complies with FCC RF exposure limits set forth for an uncontrolled environment. The equipment must not be co-located or operating in conjunction with any other antenna or transmitter.

Le présent appareil est conforme aux CNR d'Industrie Canada applicables aux appareils radio exempts de licence. L'exploitation est autorisée aux deux conditions suivantes :

- 1) l'appareil ne doit pas produire de brouillage;
- 2) l'utilisateur de l'appareil doit accepter tout brouillage radioélectrique subi, même si le brouillage est susceptible d'en compromettre le fonctionnement.