

T77H446.0X NFC Module

USER MANUAL

Project Name	T77H446.0X NFC
Revision	00
Foxconn project code	T77H446.0X

Contents

1. INTRODUCTION	1
2. HARDWARE SPECIFICATION	6
3. PRODUCT REQUIREMENTS	6
4. INTERFACE OF CONNECTOR OF NFC MODULE	7
5. ANTENNA CONNECTOR OF NFC MODULE.....	8
6. TEST OPERATING INSTRUCTIONS INFO	9

1. Introduction

The T77H446.0X NFC module provides contactless payment, contactless ticketing, service discovery, exchange information etc. This module is based on Broadcom BCM20792S1 solution, which is integrated NFC subsystem, interfaces, and microprocessor and memory unit.

1.1 Scope

The NFC module supports for the ISO/IEC 18092, ISO/IEC 21481, ISO/IEC 14443 Types A, B and B', Japanese industrial standard (JIS)(X) 6319-4, and ISO/IEC 15693 standards, etc.

1.2 Function

- NFC Features
 - Reader & Writer mode
 - Peer-to-Peer Communication mode
 - Card emulation mode
- BSC (I²C-compatible) and SM bus for host Interface,
For I²C -Bus support all speed mode:
 - Low-speed mode (100 kbps)
 - Fast mode (400 kbps)
 - High-speed mode (3.4Mbps)
- On board XTAL of 26 MHz (+/- 10ppm)
- Option for on board embedded Secure Element (eSE) with 800kBytes flash memory
Remark: eSE can be replaced by external SIM memory on platform.
- Windows 8 Logo Device Requirement compliant
 - NFC Forum Wave1 Certification
 - LLCP (Link Layer Control Protocol)
 - SNEP (Simple NDEF Exchange Protocol)
- RoHS and Green Compliant
- Support Intel Windows 7, Windows 8 platform

1.3 Electrical Characteristics

Parameter		Minimum	Typical	Maximum	Units
Frequency Range		-	13.56	-	MHz
Input Supply Voltage	VBAT	2.3	3.3	5.5	V
	VDD I/O	1.62	1.8	3.6	V
	UICC (class C)	1.78	1.88	1.98	V
	UICC (class B)	2.9	3.1	3.3	V
Power consumption	Reader mode	-	-	247	mA
	Writer mode	-	-	247	mA
	Peer to peer communication	-	-	247	mA
	Polling mode	-	-	14	mA
	Pre-polling mode	-	0.15	-	mA
	I ² C idle mode	-	2.5	-	mA
	Sleep mode	-	-	7.0	uA
	Snooze standby mode	-	94	-	uA
Communication distance		20	-	-	mm
Peer to Peer Communication Speed		-	-	424	Kbps
NFC wake up		Wake up NFC module from sleep mode by NFC_WAKE signal via I ² C command			
Operating Temperature		0	~	70	°C
Storage Temperature		-20	~	85	°C
Storage Humidity		0	~	85	%
ESD Level	HBM ^{*1}	-	2.0K	-	V
	MM	-	200	-	V

^{*1} HBM ESD level is base on without ESD protection components on TX1 and TX2. When assemble the ESD protection component, the ESD level can up to 8KV.

1.4 BSC (I²C -compatible) Characteristics

Following are the main features of NFC module I²C interface

- Slave mode
- Low-speed mode (100kbps), fast mode (400kbps), and high-speed mode (3.4Mbps)
- 7-bit or 10-bit addressing mode, default boot-up of fixed 7-bit address (0x77), thereafter configurable to 7-bit or 10-bit addresses
- Dedicated TX and RX FIFOs, 272 bytes each.

BSC Timing waveform

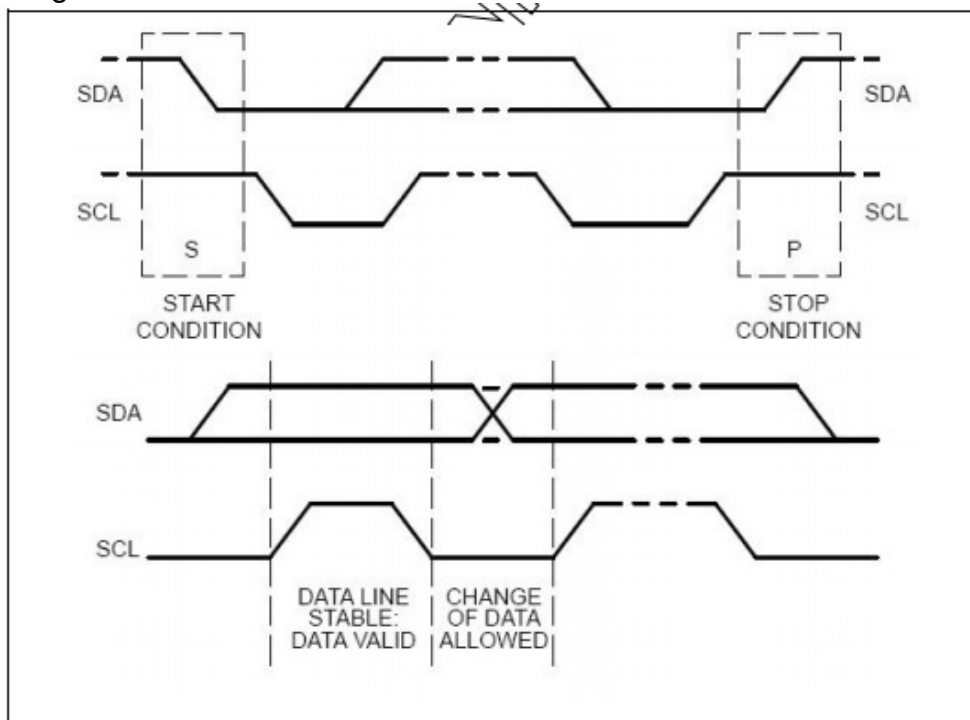

I²C _REQ is an output signal from the module to the host that it wishes to communicate. The timing diagram as below shows I²C _REQ as active high. The I²C _REQ signal stays high until after the first byte has been read by the host.

I²C _REQ timing waveform

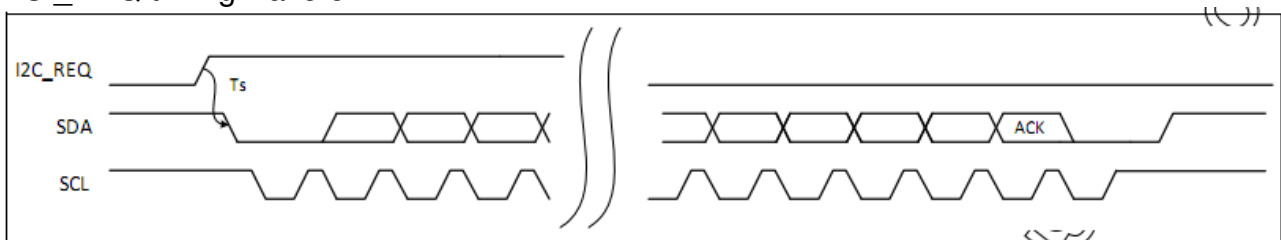

2. Hardware Specification

2.1 Antenna Electrical Specification

Parameter	Typical	Units
Operating frequency range	13.56	MHz
Communication distance	> 20	mm

3. Product Requirements

3.1 Hardware Requirements of NFC module

Form factor	15 mm x15mm module with 11-pin FPC connector
Host Interface	BSC (I ² C -compatible) interface
PCB	4-layer design

3.2 Hardware Architecture of NFC module

The T77H446.0X NFC module is based on Broadcom BCM20792S1 solution, which is integrated NFC subsystem, interfaces, and microprocessor and memory unit. This module is powered from the host (3.3V) and interfaces to the host with I²C signals and with one-printed antennas, one on-board 26 MHz XTAL and option for one Secure Element (eSE) with 800kBytes flash memory.

The functional block diagram is shown as below.

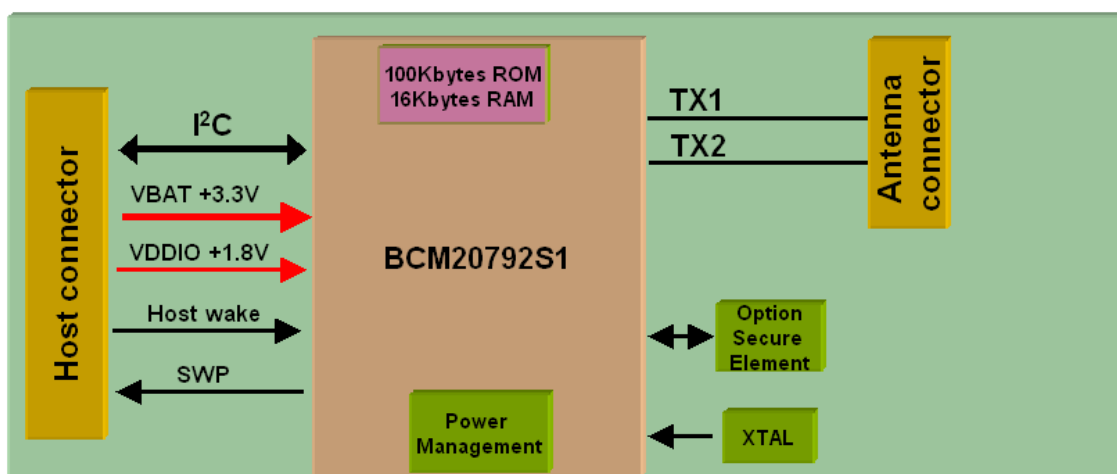

4. Interface of Connector of NFC module

Manufacturer: JST

Manufacturer Part number: 11FHSY-RSM1-GAN-TB(HF)

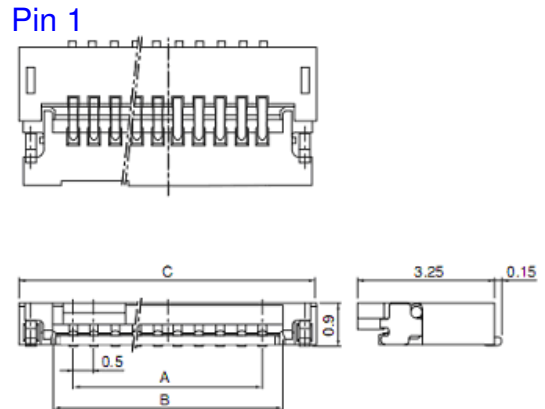
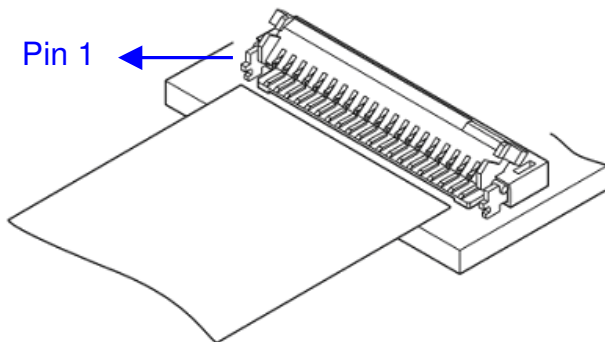

極数	形番	寸法 (mm)			個数/ リール
		A	B	C	
11	11FHSY-RSM1-GAN-TB	5.0	6.0	7.56	3,000

Pin definition

Pin	Symbol	I/O	Note
1	VBAT	Input	Power supply from battery (2.3V - 5.5V)
2	VDDIO	Input	Power supply to I/O (1.62V - 3.6V)
3	I ² C -SDA	I/O	BSC Serial Data Line, active low
4	I ² C -SCL	I	BSC Serial Clock
5	GND	G	Ground
6	IRQ-NFC	O	BSC request, active high
7	NFC_PRESENCE	G	Ground
8	REG_UP	I	NFC Power-on
9	VDD_Ext_SE	Output	Power supply to External Secure Element (1.65V - 1.95V)
10	UIM_PWR	Input	Power supply to UICC
11	SWP	I	SWP I/O 0 (Single-Wire Protocol interface)
S1	GND	G	Ground
S2	GND	G	Ground

Remark: The connector is bottom conduct with golden plating of FPC cable.

5. Antenna connector of NFC module

Manufacturer: JST

Manufacturer Part number: BM03B-ACHKS-GAN-TF(HF)

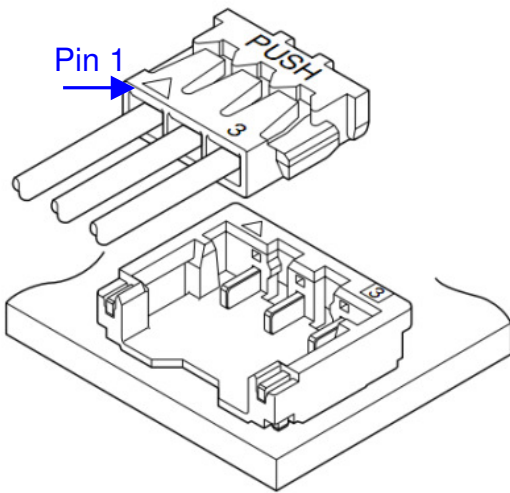

Top view

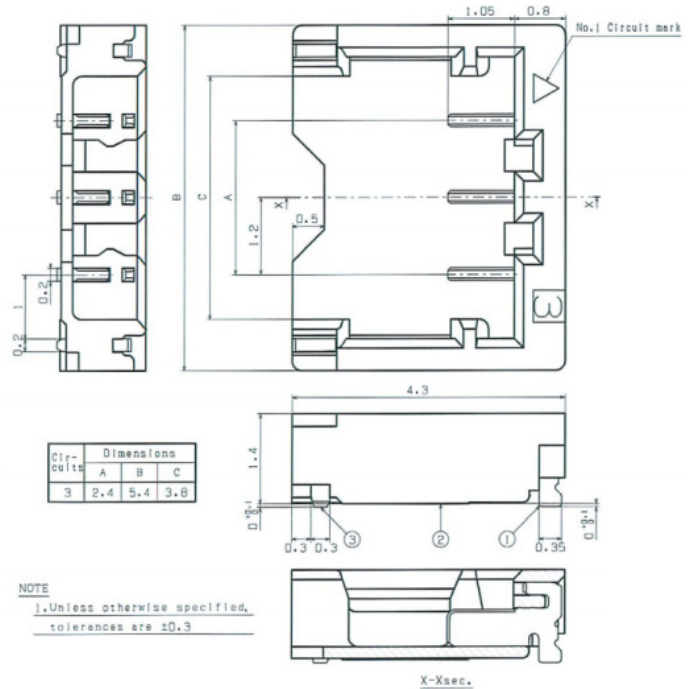

Pin definition

Pin	Symbol	I/O	Note
1	TX2	I/O	Coil output 2
2	GND	G	Ground
3	TX1	I/O	Coil output 1
S1	GND	G	Ground
S2	GND	G	Ground

6. Test Operating Instructions Info

Please refer to another file named “Test SOP for T77H446.0X NFC series projects”.



Industry Canada statement:

This device complies with RSS-210 of the Industry Canada Rules. Operation is subject to the following two conditions: (1) This device may not cause harmful interference, and (2) this device must accept any interference received, including interference that may cause undesired operation.

Ce dispositif est conforme à la norme CNR-210 d'Industrie Canada applicable aux appareils radio exempts de licence. Son fonctionnement est sujet aux deux conditions suivantes: (1) le dispositif ne doit pas produire de brouillage préjudiciable, et (2) ce dispositif doit accepter tout brouillage reçu, y compris un brouillage susceptible de provoquer un fonctionnement indésirable.

Radiation Exposure Statement:

This equipment complies with IC radiation exposure limits set forth for an uncontrolled environment. This equipment should be installed and operated with minimum distance 20cm between the radiator & your body.

Déclaration d'exposition aux radiations:

Cet équipement est conforme aux limites d'exposition aux rayonnements IC établies pour un environnement non contrôlé. Cet équipement doit être installé et utilisé avec un minimum de 20 cm de distance entre la source de rayonnement et votre corps.

This device is intended only for OEM integrators under the following conditions: (For module device use)

- 1) The antenna must be installed such that 20 cm is maintained between the antenna and users, and
 - 2) The transmitter module may not be co-located with any other transmitter or antenna.
- As long as 2 conditions above are met, further transmitter test will not be required. However, the OEM integrator is still responsible for testing their end-product for any additional compliance requirements required with this module installed.

Cet appareil est conçu uniquement pour les intégrateurs OEM dans les conditions suivantes: (Pour utilisation de dispositif module)

- 1) L'antenne doit être installée de telle sorte qu'une distance de 20 cm est respectée entre l'antenne et les utilisateurs, et
 - 2) Le module émetteur peut ne pas être coïmplanté avec un autre émetteur ou antenne.
- Tant que les 2 conditions ci-dessus sont remplies, des essais supplémentaires sur l'émetteur ne seront pas nécessaires. Toutefois, l'intégrateur OEM est toujours responsable des essais sur son produit final pour toutes exigences de conformité supplémentaires requis pour ce module installé.

IMPORTANT NOTE:



COMPANY CONFIDENTIAL

In the event that these conditions can not be met (for example certain laptop configurations or co-location with another transmitter), then the Canada authorization is no longer considered valid and the IC ID can not be used on the final product. In these circumstances, the OEM integrator will be responsible for re-evaluating the end product (including the transmitter) and obtaining a separate Canada authorization.

NOTE IMPORTANTE:

Dans le cas où ces conditions ne peuvent être satisfaites (par exemple pour certaines configurations d'ordinateur portable ou de certaines co-localisation avec un autre émetteur), l'autorisation du Canada n'est plus considéré comme valide et l'ID IC ne peut pas être utilisé sur le produit final. Dans ces circonstances, l'intégrateur OEM sera chargé de réévaluer le produit final (y compris l'émetteur) et l'obtention d'une autorisation distincte au Canada.

End Product Labeling

This transmitter module is authorized only for use in device where the antenna may be installed such that 20 cm may be maintained between the antenna and users. The final end product must be labeled in a visible area with the following: "Contains IC: 2878D-T77H446".

Plaque signalétique du produit final

Ce module émetteur est autorisé uniquement pour une utilisation dans un dispositif où l'antenne peut être installée de telle sorte qu'une distance de 20cm peut être maintenue entre l'antenne et les utilisateurs. Le produit final doit être étiqueté dans un endroit visible avec l'inscription suivante: "Contient des IC: 2878D- T77H395".

Manual Information To the End User

The OEM integrator has to be aware not to provide information to the end user regarding how to install or remove this RF module in the user's manual of the end product which integrates this module.

The end user manual shall include all required regulatory information/warning as show in this manual.

Manuel d'information à l'utilisateur final

L'intégrateur OEM doit être conscient de ne pas fournir des informations à l'utilisateur final quant à la façon d'installer ou de supprimer ce module RF dans le manuel de l'utilisateur du produit final qui intègre ce module.

Le manuel de l'utilisateur final doit inclure toutes les informations réglementaires requises et avertissements comme indiqué dans ce manuel.



COMPANY CONFIDENTIAL

Federal Communication Commission Interference Statement

This device complies with Part 15 of the FCC Rules. Operation is subject to the following two conditions: (1) This device may not cause harmful interference, and (2) this device must accept any interference received, including interference that may cause undesired operation.

This equipment has been tested and found to comply with the limits for a Class B digital device, pursuant to Part 15 of the FCC Rules. These limits are designed to provide reasonable protection against harmful interference in a residential installation. This equipment generates, uses and can radiate radio frequency energy and, if not installed and used in accordance with the instructions, may cause harmful interference to radio communications. However, there is no guarantee that interference will not occur in a particular installation. If this equipment does cause harmful interference to radio or television reception, which can be determined by turning the equipment off and on, the user is encouraged to try to correct the interference by one of the following measures:

- Reorient or relocate the receiving antenna.
- Increase the separation between the equipment and receiver.
- Connect the equipment into an outlet on a circuit different from that to which the receiver is connected.
- Consult the dealer or an experienced radio/TV technician for help.

FCC Caution: Any changes or modifications not expressly approved by the party responsible for compliance could void the user's authority to operate this equipment. This transmitter must not be co-located or operating in conjunction with any other antenna or transmitter.

Radiation Exposure Statement:

This equipment complies with FCC radiation exposure limits set forth for an uncontrolled environment. This equipment should be installed and operated with minimum distance 20cm between the radiator & your body.

This device is intended only for OEM integrators under the following conditions:

- 1) The antenna must be installed such that 20 cm is maintained between the antenna and users, and
- 2) The transmitter module may not be co-located with any other transmitter or antenna.

As long as 2 conditions above are met, further transmitter test will not be required. However, the OEM integrator is still responsible for testing their end-product for any additional compliance requirements required with this module installed



COMPANY CONFIDENTIAL

IMPORTANT NOTE: In the event that these conditions can not be met (for example certain laptop configurations or co-location with another transmitter), then the FCC authorization is no longer considered valid and the FCC ID can not be used on the final product. In these circumstances, the OEM integrator will be responsible for reevaluating the end product (including the transmitter) and obtaining a separate FCC authorization.

End Product Labeling

This transmitter module is authorized only for use in device where the antenna may be installed such that 20 cm may be maintained between the antenna and users. The final end product must be labeled in a visible area with the following: "Contains FCC ID: MCLT77H446". The grantee's FCC ID can be used only when all FCC compliance requirements are met.

Manual Information To the End User

The OEM integrator has to be aware not to provide information to the end user regarding how to install or remove this RF module in the user's manual of the end product which integrates this module.

The end user manual shall include all required regulatory information/warning as show in this manual.

For Taiwan 警語：

經型式認證合格之低功率射頻電機，非經許可，公司、商號或使用者均不得擅自變更頻率、加大功率或變更原設計之特性及功能。

低功率射頻電機之使用不得影響飛航安全及干擾合法通信；經發現有干擾現象時，應立即停用，並改善至無干擾時方得繼續使用。前項合法通信，指依電信法規定作業之無線電通信。低功率射頻電機須忍受合法通信或工業、科學及醫療用電波輻射性電機設備之干擾。

Note: 1. 本模組於取得認證後將依規定於模組本體標示審驗合格標籤 2. 系統廠商應於平台上標示「本產品內含射頻模組:  XXXyyyLPDzzzz-x (NCC ID) 」字樣