

## D6

## 双通道智能充电器

外观专利：201730627674.9 无线专利：201721700843.8

## 功能参数

输入电压	DC 6.5~30V	平衡电流	最大1600mA x 2
充电电流	0.1~15A x 2	放电电流	0.1~3A x 2
充电功率	DC 325W x 2	外部放电电流	1~15A x 2
放电功率	内部放电: 15W x 2(平衡口10Wx2)	USB输出口	5V / 2.1A
	外部放电: 325W x 2(650W)	存储温度	-20~60°C
电池类型	LiHv/LiPo/LiFe/LiIon/Lixx : 1~6S NiZn/Nicd/NiMH : 1~16S Smart Battery : 1~6S Lead Acid(Pb) : 2~24V Enelop : 1~16S	工作温度	0~40°C
		显示屏尺寸	2.8" 320×240 26万色
		外形尺寸	108mm×105mm×76mm
		净重	360g

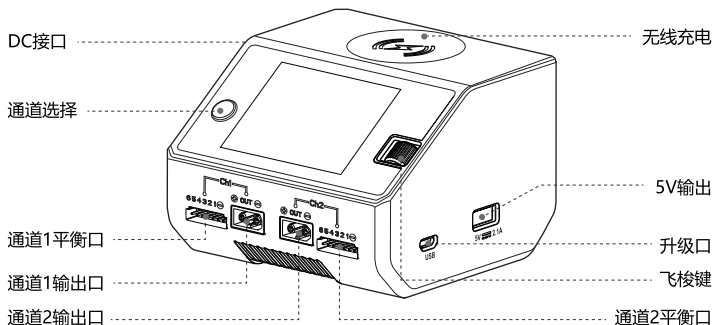

## 使用说明

- 1、连接电源、等待开机自检完成；
- 2、选择已连接好电池的通道；
- 3、通过显示屏及飞梭键设置适用于您的电池的充电参数；
- 4、开始享用。



警告!



远离火源!

## 安全注意事项:

接入电源前请确保电源输出电压与充电器工作电压范围相符。

- 1、使用过程中确保充电器远离热源及潮湿环境，并注意通风散热；
- 2、切勿让儿童操作充电器，请勿让充电器离开视线范围工作；
- 3、正确设定电池充放电的参数，错误的设定可能导致意外；
- 4、使用结束后，应尽快断开输入电源及移除电池。

## D6

### Dual Channel Smart Charger

Appearance Patent: 201730627674.9    Wireless Patent: 201721700843.8

#### Specifications

Input Voltage	DC 6.5~30V	Balance Current	1600mA x 2
Charge Current	0.1~15A x 2	Discharge Current	0.1~3A x 2
Charge Power	DC 325W x 2	External Discharge Current	1~15A x 2
Discharge Power	Internal discharge:15W x 2(balance port 10W)	USB Output	5V / 2.1A
	External discharge:325W x 2(650W)	Storage Temperature	-20~60°C
Battery Type	LiHv/LiPo/LiFe/Lilon/Lixx : 1~6S	Working Temperature	0~40°C
	NiZn/Nicd/NiMH : 1~16S	Screen Size	2.8" 320x240 260000 colors
	Smart Battery : 1~6S	Dimensions	108x105x76mm
	Lead Acid(Pb) : 2~24V Enelop : 1~16S	Net Weight	360g

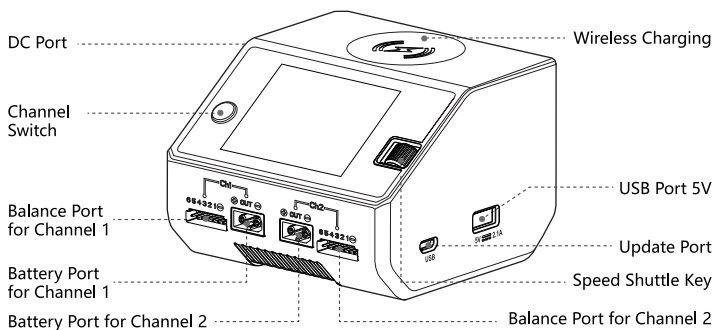

#### Instructions

1. Connect the power supply, wait for self-testing to be completed;
2. Select the channel you wanna use then connect your battery to the chosen channel;
3. Set up charging parameters applicable to your battery through the display and speed shuttle key;
4. Enjoy.



**WARNING!**



**FIRE HAZARD!**

#### **NEVER USE CHARGER UNSUPERVISED!**

- Batteries pose a SEVERE risk of fire if not properly handled.
- Read Entire operation manual before using charger.
- This unit may emit heat during use.
- Only operate this device in a cool ventilated area away from flammable objects.
- Failure to observe safety procedures may cause damages to property or injury.

## **FCC STATEMENT :**

This device complies with Part 15 of the FCC Rules. Operation is subject to the following two conditions:

- (1) This device may not cause harmful interference, and
- (2) This device must accept any interference received, including interference that may cause undesired operation.

**Warning:** Changes or modifications not expressly approved by the party responsible for compliance could void the user's authority to operate the equipment.

NOTE: This equipment has been tested and found to comply with the limits for a Class B digital device, pursuant to Part 15 of the FCC Rules. These limits are designed to provide reasonable protection against harmful interference in a residential installation. This equipment generates uses and can radiate radio frequency energy and, if not installed and used in accordance with the instructions, may cause harmful interference to radio communications. However, there is no guarantee that interference will not occur in a particular installation. If this equipment does cause harmful interference to radio or television reception, which can be determined by turning the equipment off and on, the user is encouraged to try to correct the interference by one or more of the following measures:

- Reorient or relocate the receiving antenna.

- Increase the separation between the equipment and receiver.

- Connect the equipment into an outlet on a circuit different from that to which the receiver is connected.

- Consult the dealer or an experienced radio/TV technician for help.

## **FCC Radiation Exposure Statement:**

This equipment complies with FCC radiation exposure limits set forth for an uncontrolled environment. This equipment should be installed and operated with minimum distance 10cm between the radiator & your body.