

HP Photosmart 320 series User's Guide

English



Copyrights and trademarks

© Copyright 2004 Hewlett-Packard Development Company, L.P.

The information contained herein is subject to change without notice. Reproduction, adaptation or translation without prior written permission is prohibited, except as allowed under the copyright laws.

Notice

The only warranties for HP products and services are set forth in the express warranty statements accompanying such products and services. Nothing herein should be construed as constituting an additional warranty. HP shall not be liable for technical or editorial errors or omissions contained herein.

The Hewlett-Packard Development Company, L.P. shall not be liable for incidental or consequential damages in connection with, or arising out of the furnishing, performance, or use of this document and the program material which it describes.

Trademarks

HP, the HP logo, and Photosmart are property of Hewlett-Packard Development Company, L.P.

The Secure Digital logo is a trademark of the SD Association.

Microsoft and Windows are registered trademarks of Microsoft Corporation.

CompactFlash, CF, and the CF logo are trademarks of the CompactFlash Association (CFA).

Memory Stick, Memory Stick Duo, Memory Stick PRO, and Memory Stick PRO Duo are trademarks or registered trademarks of Sony Corporation.

MultiMediaCard is a trademark of Infineon Technologies AG of Germany, and is licensed to the MMCA (MultiMediaCard Association). SmartMedia is a trademark of Toshiba Corporation.

xD-Picture Card is a trademark of Fuji Photo Film Co., Ltd., Toshiba Corporation, and Olympus Optical Co., Ltd.

Mac, the Mac logo, and Macintosh are registered trademarks of Apple Computer, Inc.

The Bluetooth word mark and logos are owned by the Bluetooth SIG, Inc.

and any use of such marks by Hewlett-Packard Company is under license.

PictBridge and the PictBridge logo are trademarks of the Camera & Imaging Products Association (CIPA).

Other brands and their products are trademarks or registered trademarks of their respective holders.

The embedded software in the printer is based in part on the work of the Independent JPEG Group.

The copyrights to certain photos within this document are retained by the original owners.

Regulatory model identification number SDGOA-0406

For regulatory identification purposes, your product is assigned a Regulatory Model Number. The Regulatory Model Number for your product is SDGOA-0406. This regulatory number should not be confused with the marketing name (HP Photosmart 320 series printer) or product number (Q3414A).

Safety information

Always follow basic safety precautions when using this product to reduce risk of injury from fire or electric shock.



Warning To prevent fire or shock hazard, do not expose this product to rain or any type of moisture.

- Read and understand all instructions in the *HP Photosmart Setup Guide*.
- Use only a grounded electrical outlet when connecting the unit to a power source. If you do not know whether the outlet is grounded, check with a qualified electrician.
- Observe all warnings and instructions marked on the product.
- Unplug this product from wall outlets before cleaning.
- Do not install or use this product near water or when you are wet.
- Install the product securely on a stable surface.
- Install the product in a protected location where no one can step

on or trip over the power cord, and where the power cord will not be damaged.

- If the product does not operate normally, see the troubleshooting information in the onscreen HP Photosmart Printer Help.
- There are no operator serviceable parts inside. Refer servicing to qualified service personnel.
- Use in a well-ventilated area.

Environmental statements

Hewlett-Packard Company is committed to providing quality products in an environmentally sound manner.

Protecting the environment

This printer has been designed with several attributes to minimize impact on our environment. For more information, go to HP's Commitment to the Environment website at www.hp.com/hpinfo/globalcitizenship/environment/.

Ozone production

This product generates no appreciable ozone gas (O₃).

Energy consumption

Energy usage drops significantly while in ENERGY STAR® mode, which saves natural resources and saves money without affecting the high performance of this product. This product qualifies for ENERGY STAR, which is a voluntary program established to encourage the development of energy-efficient office products.



ENERGY STAR is a U.S. registered mark of the U.S. EPA. As an ENERGY

STAR partner, Hewlett-Packard Company has determined that this product meets the ENERGY STAR guidelines for energy efficiency. For more information, go to www.energystar.gov.

Paper use

This product is suited for the use of recycled paper according to DIN 19309.

Plastics

Plastic parts over 0.88 ounces (24 grams) are marked according to international standards that enhance the ability to identify plastics for recycling purposes at the end of the printer life.

Material safety data sheets

Material Safety Data Sheets (MSDS) can be obtained from the HP website at www.hp.com/go/msds. Customers without Internet access should contact Customer Care.

Recycling program

HP offers an increasing number of product return and recycling programs in many countries, and partners with some of the largest electronics recycling centers throughout the world. HP conserves resources by reselling some of its most popular products.

This HP product contains lead in the solder, which may require special handling at the end of its life.

Contents

1	Welcome	3
	Printer parts.....	4
	Available accessories.....	7
	Printer menu.....	8
2	Getting ready to print	13
	Loading paper.....	13
	Choosing the right paper.....	13
	Loading your paper.....	14
	Inserting print cartridges.....	14
	Inserting memory cards.....	17
	Supported file formats.....	18
	Inserting a memory card.....	18
	Removing a memory card.....	19
3	Printing without a computer	21
	Getting your photos from camera to printer.....	21
	Deciding which photos to print.....	22
	Selecting photos to print.....	22
	Improving the quality of your photos.....	24
	Printing your photos.....	24
	Selecting a layout.....	24
	Setting print quality.....	25
	Selecting a print method.....	25
4	Getting connected	29
	Connecting to other devices.....	29
	Connecting through HP Instant Share.....	30
5	Maintaining and transporting the printer	31
	Cleaning and maintaining the printer.....	31
	Cleaning the outside of the printer.....	31
	Cleaning the print cartridge.....	31
	Cleaning the print cartridge contacts.....	32
	Printing a test page.....	32
	Aligning the print cartridge.....	33
	Storing the printer and print cartridges.....	34
	Storing the printer.....	34
	Storing the print cartridges.....	34
	Maintaining the quality of photo paper.....	35
	Storing photo paper.....	35
	Handling photo paper.....	35
	Transporting the printer.....	35
6	Troubleshooting	37
	Printer hardware problems.....	37
	Printing problems.....	40
	Bluetooth printing problems.....	42
	Error messages.....	44

7	Specifications	47
	System requirements.....	47
	Printer specifications.....	48
8	HP Customer Care	51
	HP Customer Care by phone.....	51
	Placing a call.....	52
	Return to HP repair service.....	53
a	Installing the software	55
	Index	57

1 Welcome

Thank you for purchasing an HP Photosmart 320 series printer! With your new, compact photo printer you can easily print beautiful photos with or without a computer.

This guide explains how to print photos from the printer without connecting it to a computer. To learn how to print from your computer, install the printer software and view the onscreen Help. See [Installing the software](#).

Among other things, you'll learn how to:



Print beautiful borderless photos. See [Printing your photos](#).



Improve the quality of your photos by sharpening them and improving the contrast. See [Improving the quality of your photos](#).

Your new printer comes with the following documentation:

- **Setup Guide:** The *HP Photosmart 320 series Setup Guide* explains how to set up the printer and print your first photo.
- **User's Guide:** The *HP Photosmart 320 series User's Guide* is the book you are reading. This book describes the basic features of the printer, explains how to use the printer without connecting a computer, and contains hardware troubleshooting information.
- **HP Photosmart Printer Help:** The onscreen HP Photosmart Printer Help describes how to use the printer with a computer and contains software troubleshooting information.

After you have installed the HP Photosmart printer software on your computer, you can view the onscreen Help:

- **Windows PC:** From the **Start** menu, select **Programs** (in Windows XP, select **All Programs**) > **HP > Photosmart 320, 370, 7400, 7800, 8100, 8400, 8700 series > Photosmart Help**.
- **Macintosh:** Select **Help > Mac Help** in the Finder, then select **Library > HP Photosmart Printer Help for Macintosh**.

Printer parts



Front of printer

1. **Control panel**
Control the basic functions of the printer from here.
2. **Out tray (closed)**
Open this to print, insert a memory card, connect a compatible digital camera, or connect an HP iPod.



Inside front of printer

1. **In tray**
Load paper here.
2. **In tray extender**
Pull out to support paper.
3. **Paper-width guide**
Move to the width of current paper to position the paper properly.
4. **Camera port**
Connect a PictBridge digital camera, the optional HP Bluetooth wireless printer adapter, or an HP iPod to this port.
5. **Memory card slots**
Insert memory cards into these slots. See [Inserting memory cards](#).
6. **Print cartridge door**
Open to insert or remove a print cartridge.
7. **Out tray (open)**
The printer deposits printed photos here.



Rear of printer

1. **USB port**
Use this port to connect the printer to a computer or to an HP direct-printing digital camera.
2. **Power cord connection**
Connect the power cord here.

(continued)



Indicator lights

- 1. On light**
 - Green: printer is on
 - Green and flashing: printer is busy
 - Red and flashing: printer requires attention
- 2. Memory Card light**

The light indicates the memory card status. See [Inserting memory cards](#).

 - Green: ready for memory card insertion or removal
 - Green and flashing: memory card is being accessed

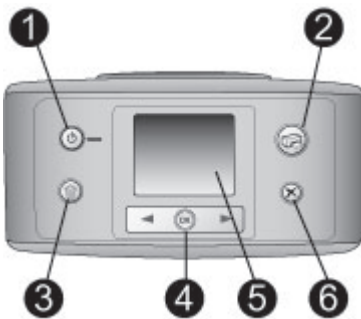

Control panel

- 1. On**

Press to turn the printer on or off.
- 2. Print**

Press to print selected photos from a memory card.
- 3. Delete**

Press to delete the currently selected photo from a memory card.
- 4. Select Photos buttons**

Use the arrows to scroll through photos on a memory card or navigate the printer menu. Press **OK** to select a photo or menu option.
- 5. Printer screen**

View photos and menus here.
- 6. Cancel**

Press to deselect photos, exit a menu, or stop an action.



Idle screen

- 1. Battery indicator**

Displays the charge level of the HP Photosmart Internal battery, if installed.

A solidly-filled battery icon indicates a fully-charged battery. As the battery is used, the battery icon indicates the approximate amount of charge by the amount of solid fill.

A lightning bolt icon shown on top of the battery icon indicates that a power supply is connected and the battery is charging.

An outlet icon is displayed when the battery is fully charged, indicating that you can unplug the power cord and run the printer from the battery if desired. For more information about the battery, refer to the instructions that came with the battery.

2. **Ink level indicator**
Displays the ink level of the print cartridge.

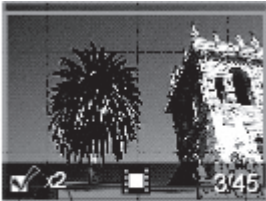

Select Photos screen

1. **Selection box**
Displays a check mark if photo is selected.
2. **Copies**
Displays number of copies to be printed of the current photo.
3. **Video clip**
Displays this icon only when you have a video clip displayed on the printer screen.
4. **Index number**
Displays index number of current photo and total number of photos on the inserted memory card.

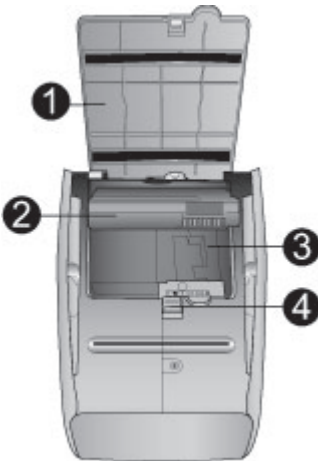





Internal battery compartment

1. **Cover of the battery compartment**
Open this cover on the bottom of the printer to insert the optional HP Photosmart Internal Battery.
2. **HP Photosmart Internal Battery** (Model: Q5599A)
A fully-charged battery has sufficient charge to print approximately 75 photos. You must purchase the battery separately.
3. **Internal battery compartment**
Insert the optional HP Photosmart Internal Battery here.
4. **Battery compartment button**
Slide to release the compartment cover.

Available accessories

There are several accessories available for the HP Photosmart 320 series printer that enhance its portability for printing anywhere, anytime. The appearance of the accessories may vary from what is shown.

Accessory name	Description
 <p>HP Photosmart Internal Battery</p>	<p>The HP Photosmart Internal Battery lets you take the printer with you wherever you go. (Model: Q5599A)</p>
 <p>HP Photosmart Automobile DC Adapter</p>	<p>The HP Photosmart Automobile DC Adapter lets you plug into your automobile for backup power and to recharge an optional HP Photosmart Internal Battery inserted in the printer. (Model: Q3448A)</p>
 <p>HP Photosmart Carrying Case for Compact Printers</p>	<p>The lightweight, durable HP Photosmart Carrying Case for Compact Printers holds and protects everything needed for hassle-free printing on the go. (Model: Q3424A)</p>
 <p>HP Bluetooth® wireless printer adapter</p>	<p>The HP Bluetooth® wireless printer adapter goes into the camera port on the front of the printer and lets you use Bluetooth wireless technology for printing. (Model: Q3395A)</p>

Printer menu

The printer menu contains many features for adjusting defaults, controlling print quality, and using special effects.

To use the printer menu

1. If there is a memory card in the printer, remove it.
2. Press ◀ or ▶ on the printer control panel to access the printer menu.

To navigate the printer menu

- Press ◀ or ▶ to scroll through the menu options displayed on the printer screen. Menu items that are not accessible are grayed out.
- Press **OK** to open a menu or select an option.
- Press **Cancel** to exit the current menu.

Printer menu structure

Top level menu	Submenus/options	Additional submenus/ options	
Tools	Print quality	Print quality: <ul style="list-style-type: none"> • Best (default) • Normal 	
	Print sample page	Sample page for use in a demo of the printer.	
	Print test page	Page of information about the printer: serial number, firmware version, and so on.	
	Clean cartridge		Continue to second level cleaning? <ul style="list-style-type: none"> • Yes • No
			Continue to third level cleaning? <ul style="list-style-type: none"> • Yes • No
	Align printer	Select to align the print cartridge.	
Bluetooth The Bluetooth menu options are needed if you equip the printer with the	Device address	Device address: Some devices with Bluetooth wireless technology require you to	

Printer menu structure (continued)

Top level menu	Submenus/options	Additional submenus/ options
optional HP Bluetooth wireless printer adapter.		enter the address of the device they are trying to locate. This menu option shows the device address.
	Device name	You can select a device name for the printer that appears on other devices with Bluetooth wireless technology when they locate the printer.
	Passkey	You can assign a Bluetooth numerical passkey to the printer. The default passkey is 0000. When the Security level is set to High (see later in this table), users of devices with Bluetooth wireless technology must enter this passkey before they can print.
	Accessibility	<p>Accessibility:</p> <ul style="list-style-type: none"> • Visible to all • Not visible <p>When Accessibility is set to Not visible, only devices that know the device address can print to it.</p> <p>You can set the Bluetooth-equipped printer to be visible or invisible to other devices with Bluetooth wireless technology by changing this accessibility option.</p>
	Security level	<p>Security Level:</p> <ul style="list-style-type: none"> • Low (default) <p>The printer does not require users of other devices with Bluetooth wireless</p>

Printer menu structure (continued)

Top level menu	Submenus/options	Additional submenus/options
		<p>technology to enter the printer passkey.</p> <ul style="list-style-type: none"> High <p>The printer does require users of other devices with Bluetooth wireless technology to enter the printer passkey.</p>
	Reset Bluetooth options	<p>Reset Bluetooth options:</p> <ul style="list-style-type: none"> Yes No (default)
Help	Cartridges	Press ◀ or ▶ to scroll
	Photo sizes	Press ◀ or ▶ to scroll
	Paper loading	Press ◀ or ▶ to scroll
	Paper jam	Press ◀ or ▶ to scroll
	Camera connect	Press ◀ or ▶ to scroll
Preferences	Smart focus	<p>Smart focus:</p> <ul style="list-style-type: none"> On (default) Off
	Digital flash	<p>Digital Flash:</p> <ul style="list-style-type: none"> On Off (default)
	Date/time	<p>Date/time stamp:</p> <ul style="list-style-type: none"> Date/time Date only Off (default)
	Colorspace	<p>Choose colorspace:</p> <ul style="list-style-type: none"> Adobe RGB sRGB Auto-select (default) <p>The Auto-select default tells the printer to use the Adobe RGB colorspace, if available. The printer defaults to sRGB if Adobe RGB is not available.</p>

Printer menu structure (continued)

Top level menu	Submenus/options	Additional submenus/ options
	Borderless	Turn borderless printing: <ul style="list-style-type: none"> ● On (default) ● Off When borderless printing is turned off, all pages print with a narrow white border around the outside edges of the paper.
	After printing	After printing, deselect all photos: <ul style="list-style-type: none"> ● Always (default) ● Never ● Ask
	Passport photo mode	Turn passport photo mode: <ul style="list-style-type: none"> ● On ● Off (default) Select Size: Passport mode tells the printer to print all selected photos in the selected passport photo size. A separate page is printed for each selected photo. Each printed page contains the number of photos of the selected size that will fit on the page.
	Preview animation	Turn preview animation: <ul style="list-style-type: none"> ● On (default) ● Off Select Off to bypass printer screen animations.
	Restore defaults	Restore original factory preferences: <ul style="list-style-type: none"> ● Yes ● No
	Language	Select language: Select country/region:

2 Getting ready to print

Before you can begin printing, there are three easy procedures you should become familiar with:

- Loading paper (see Loading paper)
- Inserting print cartridges (see Inserting print cartridges)
- Inserting a memory card (see Inserting memory cards)

You must load paper and insert a print cartridge before inserting a memory card.

Loading paper

Learn how to choose the right paper for your print job and how to load it into the In tray for printing.

Choosing the right paper

For a list of available HP-designed inkjet paper or to purchase supplies, go to:

- www.hpshopping.com (U.S.)
- www.hp.com/go/supplies (Europe)
- www.hp.com/jp/supply_inkjet (Japan)
- www.hp.com/paper (Asia/Pacific)

To get the best results from the printer, choose from these high-quality HP photo papers.

To print	Use this paper
High-quality, long-lasting prints and enlargements	HP Premium Plus photo paper
Medium- to high-resolution images from scanners and digital cameras	HP Premium photo paper
Casual and business photos	HP photo paper HP Everyday photo paper

To keep your paper in good condition for printing:

- Store unused paper in its original package.
- Keep the paper flat in a cool, dry place. If the corners curl, place the paper in a plastic bag and gently bend it in the opposite direction until it lies flat.
- Hold photo paper by the edges to avoid smears.

Loading your paper

Paper loading tips:

- You can print photos on photo paper, index cards, L-size cards, or Hagaki cards.
- Before loading paper, slide out the paper-width guide to make room for the paper.
- Load only one type and size of paper at a time. Do not mix paper types or sizes in the In tray.

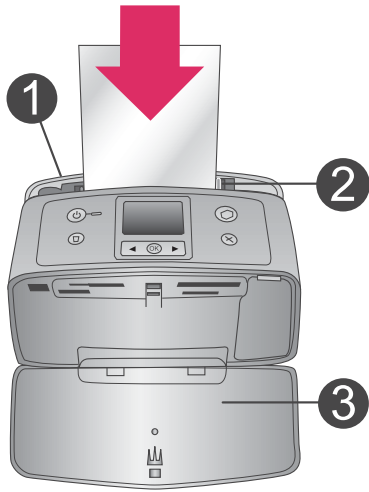
Paper type	How to load	
4 x 6 inch (10 x 15 cm) photo paper Index cards L-size cards Hagaki cards	<ol style="list-style-type: none"> 1. Open the In tray and pull out the In tray extender. 2. Load up to 20 sheets of paper with the print side or glossy side facing towards you. When loading, push the paper down firmly until it stops. If you are using tabbed paper, insert it so the tabbed end feeds in last. 3. Adjust the paper-width guide to fit close to the edge of the paper without bending the paper. 4. Open the Out tray to prepare for printing. 	 <ol style="list-style-type: none"> 1. In tray 2. Paper-width guide 3. Out tray

Inserting print cartridges

Your HP Photosmart 320 series printer can print color and black-and-white photos. HP provides different types of print cartridges so you can choose the best cartridge for your project. The cartridge number varies by country/region. Choose the correct cartridge number for your country/region.

For optimum printing results, HP recommends using only HP print cartridges. Inserting a cartridge that is not in this table may invalidate the printer warranty.

Use the right print cartridge

To print...	Insert this print cartridge in the cartridge cradle
Full-color photos	Tri-color (7 ml) HP #95 (North America, Latin America, Asia Pacific), #135

Use the right print cartridge (continued)

To print...	Insert this print cartridge in the cartridge cradle
	<p>(Eastern Europe, Russia, Middle East, Africa, Japan), #343 (Western Europe), #855 (China, India)</p> <p>Tri-color (14 ml) HP #97 (North America, Latin America, Asia Pacific), #134 (Eastern Europe, Russia, Middle East, Africa, Japan), #344 (Western Europe), #857 (China, India)</p>
Black and white photos	Gray Photo HP #100 (worldwide)
Sepia or antique photos	<p>Tri-color (7 ml) HP #95 (North America, Latin America, Asia Pacific), #135 (Eastern Europe, Russia, Middle East, Africa, Japan), #343 (Western Europe), #855 (China, India)</p> <p>Tri-color (14 ml) HP #97 (North America, Latin America, Asia Pacific), #134 (Eastern Europe, Russia, Middle East, Africa, Japan), #344 (Western Europe), #857 (China, India)</p>
Text and colored line drawings	<p>Tri-color (7 ml) HP #95 (North America, Latin America, Asia Pacific), #135 (Eastern Europe, Russia, Middle East, Africa, Japan), #343 (Western Europe), #855 (China, India)</p> <p>Tri-color (14 ml) HP #97 (North America, Latin America, Asia Pacific), #134 (Eastern Europe, Russia, Middle East, Africa, Japan), #344 (Western Europe), #857 (China, India)</p>



Caution Check that you are using the correct print cartridge. Also, note that HP does not recommend modifying or refilling HP cartridges. Damage that results from modifying or refilling HP cartridges is not covered by the HP warranty.

For best print quality, HP recommends that you install all retail print cartridges before the date stamped on the box.

Insert or replace the print cartridge



Remove the pink tape



Do not touch here



Prepare the printer and cartridge

1. Make sure the power is on and you have removed the cardboard from inside the printer.
2. Open the print cartridge access door of the printer.
3. Remove the bright pink tape from the cartridge.

Insert the cartridge

1. If you are replacing a cartridge, push down and pull outward on the cartridge in the cradle to remove it.
2. Hold the replacement cartridge with the label on top. Slide the cartridge at a slight upward angle into the cradle so the copper-colored contacts go in first. Push the cartridge until it snaps into place.
3. Close the print cartridge access door.

The idle screen of the printer displays an icon showing the approximate ink level for the installed cartridge (100%, 75%, 50%, 25%, and nearly empty). No ink-level icon appears if the cartridge is not a genuine HP cartridge.



Each time you install or replace a print cartridge, a message appears on the printer screen asking you to load plain paper so the printer can align the cartridge. This ensures high-quality prints.

Align the cartridge

1. Load paper in the In tray and press **OK**.
2. Follow the onscreen instructions to align the cartridge.

See [Aligning the print cartridge](#).

When you are not using a print cartridge



Whenever you remove a print cartridge from the printer, store it in a print cartridge protector. The cartridge protector keeps the ink from drying out. Storing the cartridge improperly can cause the cartridge to malfunction.

In some countries/regions the cartridge protector is not included with the printer, but comes with the Gray Photo cartridge that can be purchased separately. In other countries/regions, the protector is included with the printer.

- To insert a cartridge into the cartridge protector, slide the cartridge into the protector at a slight angle and snap it securely into place.

Inserting memory cards

After you have taken pictures with a digital camera, you can remove the memory card from the camera and insert it into the printer to view and print your photos. The printer can read the following types of memory cards: CompactFlash™, Memory Sticks, MultiMediaCard™, Secure Digital™, SmartMedia™, and xD-Picture Card™. The Microdrive is not supported.



Caution Using any other type of memory card may damage the memory card and the printer.

To learn about other ways of transferring photos from a digital camera to the printer, see [Connecting to other devices](#).

Supported file formats

The printer can recognize and print the following file formats directly from a memory card: JPEG, uncompressed TIFF, Motion JPEG AVI, Motion JPEG Quicktime, and MPEG-1. If your digital camera saves photos and video clips in other file formats, save the files to your computer and print them using a software application. For more information, see the onscreen Help.

Inserting a memory card

Find your memory card in the following table and use the instructions to insert the card into the printer.

Guidelines:





- Insert only one memory card at a time.
- Gently push the memory card into the printer until it stops. The memory card does not insert all the way into the printer; do not try to force it.











Caution 1 Inserting the memory card any other way may damage the card and the printer.

When the memory card is inserted correctly, the Memory Card light flashes and then remains solid green.

Caution 2 Do not pull out a memory card while the Memory Card light is flashing. For more information, see [Removing a memory card](#).

Memory card	Slot	How to insert the memory card
CompactFlash 	Top right slot	<ul style="list-style-type: none"> • Front label faces up, and if the label has an arrow, the arrow points toward the printer • Edge with metal pinholes goes into the printer first 
MultiMediaCard 	Bottom right slot	<ul style="list-style-type: none"> • Angled corner is on the right • Metal contacts face down 

(continued)

Memory card	Slot	How to insert the memory card
Secure Digital 	Bottom right slot	<ul style="list-style-type: none">• Angled corner is on the right• Metal contacts face down 
SmartMedia 	Upper portion of the top left double slot	<ul style="list-style-type: none">• Angled corner is on the left• Metal contacts face down 
Memory Stick 	Bottom left slot	<ul style="list-style-type: none">• Angled corner is on the left• Metal contacts face down• If you are using a Memory Stick Duo™ or Memory Stick PRO Duo™ card, attach the adapter that came with the card before you insert the card into the printer 
xD-Picture Card 	Lower right portion of the top left double slot	<ul style="list-style-type: none">• Curved side of card points toward you• Metal contacts face down 

Removing a memory card

Wait until the Memory Card light stops flashing, then gently pull the memory card to remove it from the printer.



Caution Do not pull out a memory card while the Memory Card light is flashing. A flashing light means that the printer is accessing the memory card.





Removing a memory card while it is being accessed may damage the printer and the memory card or corrupt the information on the memory card.

3 Printing without a computer

The HP Photosmart 320 series printer lets you print amazing photos without even going near a computer. After setting up the printer using the instructions in the *HP Photosmart 320 series Setup Guide*, refer to these steps for start-to-finish printing.

Getting your photos from camera to printer

Use these steps for start-to-finish printing in minutes!

<p>Step 1 Insert a memory card See Inserting memory cards.</p>	
<p>Step 2 Decide which photos to print See Deciding which photos to print.</p>	
<p>Step 3 Load paper See Loading paper.</p>	
<p>Step 4 Insert a different print cartridge for this print job, if desired See Inserting print cartridges.</p>	
<p>Step 5 Select photos to print See Selecting photos to print.</p>	

(continued)

Use these steps for start-to-finish printing in minutes!**Step 6**

Improve the quality of your photos
See Improving the quality of your photos.

**Step 7**

Print your photos
See Printing your photos.

**Deciding which photos to print**

To view photos	Do this
<p>One by one</p>	<ol style="list-style-type: none"> 1. Insert a memory card. 2. Use the ◀ or ▶ to select a layout, then press OK. See Selecting a layout. 3. Press ◀ or ▶ to view the photos one by one. Press and hold the button to view the photos rapidly. When you reach the last photo in either direction, the display returns to the first or last photo and continues.
<p>Using a photo index</p> <p>A photo index shows thumbnail views and index numbers for up to 2000 photos on a memory card. Use an index card instead of photo paper to cut costs when printing a photo index.</p>	<ol style="list-style-type: none"> 1. Insert a memory card. 2. Select Print Index Page, then press OK.

Selecting photos to print

If you want to...	Do this
<p>Print one photo</p>	<ol style="list-style-type: none"> 1. Insert a memory card and select a print layout. 2. Press Print to print the photo displayed on the printer screen, using the current print layout.
<p>Print more than one copy of a photo</p>	<ol style="list-style-type: none"> 1. Insert a memory card and select a print layout.

(continued)

If you want to...	Do this
	<ol style="list-style-type: none">2. Press OK once for each copy of the current photo you want to print. Press Cancel to decrease the number of copies by one or deselect a selected photo.3. Press Print.
Print several photos	<ol style="list-style-type: none">1. Insert a memory card and select a print layout.2. Press OK to select each photo you want to print.3. Press Print.
Print all photos	<ol style="list-style-type: none">1. Insert a memory card and select a print layout.2. Press and hold OK until a message tells you that all the photos on the card have been selected.3. Press Print.
Print nine frames from a video clip	<ol style="list-style-type: none">1. Insert a memory card that has a video clip on it.2. Press OK to select either layout option; neither one will be used for printing video clips, which are always printed nine to a page.3. Press ◀ or ▶ to scroll to the video clip you want to print (the first frame in the clip will be displayed). The video clip icon appears at the bottom of the printer screen.4. Press OK to select the video clip, then press Print. The printout will contain one page of nine frames automatically selected from the video clip. <p>Note 1 The image resolution in video clips is typically lower than that of digital photos; therefore, you may notice that the print quality of your video clip frames is lower than the print quality of your photos.</p> <p>Note 2 Not all video file formats are supported by this printer. For a list of supported video file formats, see Printer specifications.</p>

Improving the quality of your photos

The HP Photosmart 320 series printer provides a variety of preferences and effects that can improve the quality of your printed photos. The settings do not change your original photo. They only affect printing.

Problem and solution	How to do it
<p>Blurred photos</p> <p>Smart Focus</p> <p>Sharpen blurred photos. It is turned on by default. Use these instructions to turn it on if it is currently off. This preference affects all printed photos.</p>	<ol style="list-style-type: none"> 1. Remove any memory cards, then press ◀ or ▶. 2. Select Preferences, then press OK. 3. Select Smart Focus, then press OK. 4. Press ◀ or ▶ to highlight On, then press OK.
<p>Photos with poor lighting and contrast</p> <p>Digital Flash</p> <p>Improve the lighting and contrast in prints. This preference affects all printed photos.</p>	<ol style="list-style-type: none"> 1. Remove any memory cards, then press ◀ or ▶. 2. Select Preferences, then press OK. 3. Select Digital Flash, then press OK. 4. Press ◀ or ▶ to highlight On, then press OK.

Printing your photos

Printing your photos involves three steps: selecting a print layout, setting print quality, and selecting a print method.

Selecting a layout

The printer prompts you to select a print layout each time you insert a memory card.

Layout options	Do this
	<ol style="list-style-type: none"> 1. Insert a memory card. 2. Use ◀ or ▶ to select a layout: <ul style="list-style-type: none"> – Print one photo per sheet – Print two photos per sheet – Print four photos per sheet 3. Press OK. The printer may rotate your photos to fit the layout. <p>Note When borderless printing is turned off, all pages print with a narrow white border around the outside edges of the paper. To turn off borderless printing, see Printer menu.</p>

Setting print quality

Best quality is the default and produces the highest quality photos. Normal quality conserves ink and prints faster.

To change the print quality to Normal

1. Remove any memory cards, then press ◀ or ▶.
2. Select **Tools**, then press **OK**.
3. Select **Print Quality**, then press **OK**.
4. Select **Normal**, then press **OK**.

Print quality reverts to Best after the next print job.

Selecting a print method

The HP Photosmart 320 series printer lets you print from a memory card, directly from a digital camera, or from an HP iPod (with photos stored in it).

To print from a...	Do this
Memory card Print digital photos that are stored on a memory card. The photos can be unmarked or camera-selected (Digital Print Order Format, or DPOF). Printing from a memory card requires no computer and does not drain your digital camera's batteries. See Inserting memory cards .	To print unmarked photos <ol style="list-style-type: none">1. Insert a memory card.2. Select one or more photos. See Selecting photos to print.3. Press Print. To print camera-selected photos <ol style="list-style-type: none">1. Insert a memory card that contains camera-selected (DPOF) photos.2. Select Yes when the printer asks you whether you want to print the camera-selected photos, then press OK.
Digital camera Print beautiful photos from a PictBridge or HP direct-printing digital camera without using a computer. See Getting connected . When you print directly from a digital camera, the printer uses the settings that you selected on the camera. For more information on using camera-selected photos, see the documentation that came with the camera.	To print from a PictBridge camera <ol style="list-style-type: none">1. Turn on the PictBridge digital camera and select the photos you want to print.2. Make sure the camera is in PictBridge mode, then connect it to the camera port on the front of the printer using the USB cable that came with the camera. Once the printer recognizes the PictBridge camera, the selected photos print.

(continued)

To print from a...	Do this
	<p>To print from an HP direct-printing camera</p> <ol style="list-style-type: none"> 1. Turn on the HP direct-printing digital camera and select the photos you want to print. 2. Connect the camera to the USB port on the back of the printer using the USB cable that came with the camera. 3. Follow the instructions on the camera screen.
<p>HP iPod</p> <p>Print photos that are stored in an HP iPod. See Connecting to other devices.</p>	<p>Before using the steps below to import and print photos to your HP iPod, make sure your images and your HP iPod meet the following requirements:</p> <ul style="list-style-type: none"> • The images you copy to the HP iPod must be in JPEG format. • Make sure the HP iPod is formatted in Windows (FAT 32 file structure). The HP iPod defaults to the Windows file structure. To check if your HP iPod was formatted for Windows, go to Settings>About on your HP iPod. If it was formatted in Windows, it will display “Format Windows” at the bottom of the screen. If it was not formatted in Windows, you must connect the HP iPod to a Windows PC using the USB cable that came with the HP iPod and follow the onscreen instructions. <p>Note HP iPods that have only been connected to a Macintosh are not compatible with the printer; however, after connecting to a Windows PC, Macintosh users can still fully synchronize their HP iPods back to Macintosh and Mac iTunes and maintain printer support.</p> <p>To import photos to an HP iPod</p> <ol style="list-style-type: none"> 1. Copy photos from a memory card to your HP iPod using the Belkin Media Reader for iPod.

(continued)

To print from a...	Do this
	<ol style="list-style-type: none"><li data-bbox="687 170 1122 284">2. Verify that photos are on your HP iPod by selecting "Photo Import" on the HP iPod menu. Photos will appear as "Rolls." <p data-bbox="687 326 1059 352">To print photos from an HP iPod</p> <ol style="list-style-type: none"><li data-bbox="687 361 1116 591">1. Connect the HP iPod to the camera port on the front of the printer using the USB cable that came with the HP iPod. The printer screen will display Reading Device for up to several minutes while the photos are read. Then the photos will be displayed on the printer screen.<li data-bbox="687 597 1128 739">2. Select the photo(s) you want to print and press Print. For more information on selecting and printing photos, see Selecting photos to print. <p data-bbox="687 753 1110 895">If you are unable to print to the HP Photosmart 320 series printer using your HP iPod, please contact HP Customer Care. See HP Customer Care.</p>

4 Getting connected

Use the printer to stay connected to other devices and people.

Connecting to other devices

This printer offers several ways of connecting to computers or other devices. Each connection type lets you do different things.

Connection type and what you need	What this lets you do
USB <ul style="list-style-type: none">• A Universal Serial Bus (USB) 2.0 full-speed compliant cable 10 feet (3 meters) or less in length. For instructions about connecting the printer with a USB cable, see Installing the software.• A computer with Internet access (to use HP Instant Share).	<ul style="list-style-type: none">• Print from your computer to the printer.• Save photos from a memory card inserted in the printer to your computer where you can enhance or organize them using the HP Image Zone software.• Share photos through HP Instant Share.• Print directly from an HP Photosmart direct-printing digital camera to the printer. For more information, see Printing without a computer and the camera documentation.
PictBridge <p>A PictBridge-compatible digital camera and a USB cable.</p> <p>Connect the camera to the camera port on the front of the printer.</p>	Print directly from a PictBridge-compatible digital camera to the printer. For more information, see Printing without a computer and the camera documentation.
Bluetooth <p>The optional HP Bluetooth wireless printer adapter.</p> <p>If the printer came with this accessory or you have purchased it separately, see the accompanying documentation.</p>	Print from any device with Bluetooth wireless technology to the printer.
HP iPod <p>An HP iPod and the USB cable that came with it. Connect the HP iPod to the camera port on the front of the printer.</p>	Print directly from an HP iPod (with photos stored in it) to the printer. For more information, see To print photos from an HP iPod .

Connecting through HP Instant Share

Use HP Instant Share to share photos with friends and relatives using e-mail, online albums, or an online photo finishing service. The printer must be connected through a USB cable to a computer with Internet access and have all the HP software installed. If you try to use HP Instant Share and do not have all the required software installed or configured, a message prompts you through the required steps. See *Installing the software*.

To use HP Instant Share to send photos

1. Insert a memory card that contains the photos you want to share.
2. Follow the prompts on your computer to save the photos to the computer.
3. Use the HP Instant Share features of the HP Image Zone software to share your photos with others.

See the onscreen HP Image Zone Help for information about using HP Instant Share.

5 Maintaining and transporting the printer

The HP Photosmart 320 series printer requires very little maintenance. Follow the guidelines in this chapter to extend the life span of the printer and printing supplies, and to ensure that the photos you print are always of the highest quality.

Cleaning and maintaining the printer

Keep the printer and print cartridges clean and well maintained using the simple procedures in this section.

Cleaning the outside of the printer

1. Turn off the printer, then disconnect the power cord from the back of the printer.
2. If you installed the optional HP Photosmart Internal Battery in the printer, remove it, then close the battery compartment door.
3. Wipe the outside of the printer with a soft cloth that has been lightly moistened with water.



Caution 1 Do not use any type of cleaning solution. Household cleaners and detergents may damage the printer's finish.

Caution 2 Do not clean the interior of the printer. Keep all fluids away from the interior.



Cleaning the print cartridge

If you notice white lines or single-color streaks on the photos you print, the print cartridge may need to be cleaned. Do not clean the cartridge more often than necessary, since cleaning uses up ink.

1. Remove any memory cards from the memory card slots.



Caution Do not pull out a memory card while the Memory Card light is flashing. For more information, see [Removing a memory card](#).

2. Press  or  to display the printer menu.
3. Select **Tools**, then press **OK**.
4. Select **Clean cartridge**, then press **OK**.
5. Following the directions on the printer screen, load paper so the printer can print a test page after cleaning the cartridge. Use plain paper or index cards to conserve photo paper.
6. Press **OK** to begin cleaning the print cartridge.

7. When the printer finishes cleaning the cartridge and prints a test page, check the test page and select from the following options:
 - If the test page has white streaks or missing colors, the print cartridge needs to be cleaned again. Select **Yes**, then press **OK**.
 - If the print quality of the test page looks good, select **No**, then press **OK**.
 You can clean the cartridge up to three times. Each successive cleaning is more thorough and uses more ink.

If you complete all three levels of cleaning using this procedure and you still notice white streaks or missing colors on the test page, you may need to clean the print cartridge copper-colored contacts. For more information, see the following section.



Note If the cartridge or printer has been recently dropped, you may also see white streaks or missing colors in your prints. This problem is temporary and clears up within 24 hours.

Cleaning the print cartridge contacts

If you use the printer in a dusty environment, debris may accumulate on the copper-colored contacts and cause printing problems.

To clean the print cartridge contacts:

1. Gather the following items to clean the contacts:
 - Distilled water (tap water may contain contaminants that can damage the print cartridge)
 - Cotton swabs or other soft, lint-free material that will not stick to the print cartridge
2. Open the print cartridge door.
3. Remove the print cartridge and place it on a piece of paper with the ink nozzle plate facing up. Be careful not to touch the copper-colored contacts or the ink nozzle plate with your fingers.



Caution Do not leave the print cartridge outside the printer for more than 30 minutes. Ink nozzles exposed to the air longer than this may dry out and cause printing problems.

4. Lightly moisten a cotton swab with distilled water and squeeze any excess water from the swab.
5. Gently wipe the copper-colored contacts with the cotton swab.



Caution Do not touch the ink nozzle. Touching the ink nozzle will result in clogs, ink failure, and bad electrical connections.

6. Repeat steps 4–5 until no ink residue or dust appears on a clean swab.
7. Insert the print cartridge in the printer, then close the print cartridge door.



Printing a test page

Print a test page before contacting HP Customer Care. The test page contains diagnostic information you can use when working with HP Customer Care to solve printing problems. Look at the ink nozzle pattern on the test page to check the ink level and condition of the print cartridge. If any line or color is missing from the

pattern, try cleaning the print cartridge. For more information, see [Cleaning the print cartridge](#).

1. Remove any memory cards from the memory card slots.

 **Caution** Do not pull out a memory card while the Memory Card light is flashing. For more information, see [Removing a memory card](#).

2. Press  or  to display the printer menu.
3. Select **Tools**, then press **OK**.
4. Select **Print test page**, then press **OK**.
5. Following the directions on the printer screen, load paper so the printer can print a test page. Use plain paper or index cards to conserve photo paper.
6. Press **OK** to begin printing the test page.

The test page contains the following information:





Aligning the print cartridge

The first time you install a print cartridge in the printer, the printer aligns it automatically. However, if colors in printouts are misaligned, or if the alignment page does not print correctly when you installed a new print cartridge, use the following procedure to align the print cartridge.

1. Remove any memory cards from the memory card slots.

 **Caution** Do not pull out a memory card while the Memory Card light is flashing. For more information, see [Removing a memory card](#).

2. Press  or  to display the printer menu.
3. Select **Tools**, then press **OK**.
4. Select **Align cartridge**, then press **OK**.
5. A message appears on the printer screen reminding you to load plain paper. Load paper so the printer can print a calibration page. Use plain paper or index cards to conserve photo paper.

6. Press **OK** to begin aligning the print cartridge.
When the printer finishes aligning the cartridge, it prints an alignment page to confirm that the alignment was successful.



- The check marks verify that the print cartridge is installed correctly and functioning properly.
- If an “x” appears to the left of any of the bars, align the print cartridge again. If the “x” still appears, replace the print cartridge.

Storing the printer and print cartridges

Protect the printer and print cartridges by storing them properly when you are not using them.

Storing the printer

The printer is built to withstand long or short periods of inactivity.

- Close the In and Out tray doors when the printer is not in use.
- Store the printer indoors out of direct sunlight in a place without temperature extremes.
- If the printer and print cartridge have not been used for one month or more, clean the print cartridge before printing. For more information, see [Cleaning the print cartridge](#).

Storing the print cartridges

When you store or transport the printer, always leave the active print cartridge inside the printer. The printer stores the print cartridge in a protective cap during the power-down cycle.



Caution Make sure the printer completes its power-down cycle before you unplug the power cord or remove the internal battery. This allows the printer to store the print cartridge properly.

Follow these tips to help maintain HP print cartridges and ensure consistent print quality:

- When you remove a print cartridge from the printer, store it in a print cartridge protector to prevent the ink from drying out.
In some countries/regions the cartridge protector is not included with the printer, but comes with the Gray Photo cartridge that can be purchased separately. In other countries/regions, the protector is included with the printer.
- Keep all unused print cartridges in their original sealed packages until they are needed. Store print cartridges at room temperature (15–35 degrees C or 59–95 degrees F).
- Do not remove the plastic tape covering the ink nozzles until you are ready to install the print cartridge in the printer. If the plastic tape has been removed from the print cartridge, do not attempt to reattach it. Reattaching the tape damages the print cartridge.

Maintaining the quality of photo paper

For best results with photo paper, follow the guidelines in this section.

Storing photo paper

- Store the photo paper in its original packaging or in a resealable plastic bag.
- Store the packaged photo paper on a flat, cool, and dry surface.
- Return unused photo paper to the plastic bag. Paper left in the printer or exposed to the elements may curl.

Handling photo paper

- Always hold photo paper by the edges to avoid fingerprints.
- If the photo paper has curled edges, place it in its plastic storage bag and gently bend it in the opposite direction of the curl until the paper lies flat.

Transporting the printer

It's easy to transport and set up the printer almost anywhere. Take it with you on vacations and to family gatherings and social events to instantly print and share photos with family and friends.

- **HP Photosmart Internal Battery:** Power the printer with a rechargeable battery so you can print anywhere.
- **HP Photosmart Automobile DC Adapter:** Power the printer from the cigarette lighter in a car.
- **HP Photosmart Carrying Case** for compact photo printers: Carry the printer and printing supplies together in this convenient travel case.

To transport the printer:

1. Turn off the printer.
2. Remove any memory cards from the memory card slots.
3. Remove all paper from the In and Out trays, then close the In and Out tray doors.



Note Make sure the printer completes its power-down cycle before you unplug the power cord. This allows the printer to store the print cartridge properly.

4. Unplug the power cord.
5. If the printer is connected to a computer, disconnect the USB cable from the computer.
6. Always carry the printer upright.



Note Do not remove the print cartridge when transporting the printer.

Make sure to bring the following items with you:

- Paper
- Power cord
- Digital camera or a memory card containing photos
- Extra print cartridges (if you plan to print a lot of photos)
- Optional printer accessories you plan to use, such as the battery, DC adapter, or HP Bluetooth wireless printer adapter
- If you are going to connect the printer to a computer, bring the USB cable and HP Photosmart printer software CD
- Printer user's guide (the book you are reading)



Note If you do not take the printer user's guide with you, be sure to write down the correct pen numbers for the country/region you plan to visit or purchase enough print cartridges before you go.

6 Troubleshooting

The HP Photosmart printer is designed to be reliable and easy to use. This section answers frequently asked questions about using the printer and printing without a computer. It contains information about the following topics:

- Printer hardware problems. See [Printer hardware problems](#).
- Printing problems. See [Printing problems](#).
- Bluetooth printing problems. See [Bluetooth printing problems](#).
- Error messages. See [Error messages](#).

For troubleshooting information about using the printer software and printing from a computer, see the onscreen HP Photosmart Printer Help. For information about viewing the onscreen Printer Help, see [Welcome](#).

Printer hardware problems

Before contacting Customer Care, read this section for troubleshooting tips or go to the online support services at www.hp.com/support.



Note If you want to connect the printer to a computer, HP recommends using a USB cable of less than 10 feet (3 meters) in length to minimize injected noise due to potentially high electromagnetic fields.

The On light is flashing green but the printer is not printing.

- If the printer is turned on, it is busy processing information. Wait for it to finish.
- If the printer is turned off, and the optional HP Photosmart Internal Battery is installed, the battery is charging.

The On light is flashing red.

The printer requires attention. Try the following:

- Check the printer screen for instructions. If you have a digital camera connected to the printer, check the camera screen for instructions. If the printer is connected to a computer, check the computer monitor for instructions.
- Turn off the printer.

If the optional HP Photosmart Internal Battery is **not** installed in the printer:

Unplug the printer power cord. Wait about 10 seconds, then plug the power cord back in. Turn on the printer.

If the optional HP Photosmart Internal Battery is installed in the printer:

Unplug the printer power cord, if it is plugged in. Open the battery compartment cover and remove the battery. Wait about 10 seconds, then reinstall the battery. If desired, plug in the power cord. Turn on the printer.

The On light flashed amber briefly after I turned the printer off.

This is a normal part of the power-down process. It does not indicate a problem with the printer.

The On light is flashing amber.

A printer error has occurred. Try the following:

- Check the printer screen for instructions. If you have a digital camera connected to the printer, check the camera screen for instructions. If the printer is connected to a computer, check the computer monitor for instructions.
- Turn off the printer.
If the optional HP Photosmart Internal Battery is **not** installed in the printer:
Unplug the printer power cord. Wait about 10 seconds, then plug the power cord back in. Turn on the printer.
If the optional HP Photosmart Internal Battery is installed in the printer:
Unplug the printer power cord, if it is plugged in. Open the battery compartment cover and remove the battery. Wait about 10 seconds, then reinstall the battery. If desired, plug in the power cord. Turn on the printer.
- If the On light continues to flash amber, go to www.hp.com/support or contact Customer Care.

The buttons on the control panel do not respond.

A printer error has occurred. Wait for about a minute to see if the printer resets. If it does not, try the following:

- Turn off the printer.
If the optional HP Photosmart Internal Battery is **not** installed in the printer:
Unplug the printer power cord. Wait about 10 seconds, then plug the power cord back in. Turn on the printer.
If the optional HP Photosmart Internal Battery is installed in the printer:
Unplug the printer power cord, if it is plugged in. Open the battery compartment cover and remove the battery. Wait about 10 seconds, then reinstall the battery. If desired, plug in the power cord. Turn on the printer.
- If the printer does not reset, and the control panel buttons still do not respond, go to www.hp.com/support or contact Customer Care.

The printer does not find and display the photos on my memory card.

Try the following:

- Turn off the printer.
If the optional HP Photosmart Internal Battery is **not** installed in the printer:
Unplug the printer power cord. Wait about 10 seconds, then plug the power cord back in. Turn on the printer.

If the optional HP Photosmart Internal Battery is installed in the printer:

Unplug the printer power cord, if it is plugged in. Open the battery compartment cover and remove the battery. Wait about 10 seconds, then reinstall the battery. If desired, plug in the power cord. Turn on the printer.

- The memory card may contain file types the printer cannot read directly from the memory card.
 - Save the photos to a computer, then print them from the computer. For more information, see the documentation that came with the camera and the onscreen HP Photosmart Printer Help.
 - The next time you take photos, set the digital camera to save them in a file format the printer can read directly from the memory card. For a list of supported file formats, see [Printer specifications](#). For instructions on setting the digital camera to save photos in specific file formats, see the documentation that came with the camera.

The printer is plugged in, but it will not turn on.

- The printer may have drawn too much power.

If the optional HP Photosmart Internal Battery is **not** installed in the printer:
Unplug the printer power cord. Wait about 10 seconds, then plug the power cord back in. Turn on the printer.

If the optional HP Photosmart Internal Battery is installed in the printer:
Unplug the printer power cord, if it is plugged in. Open the battery compartment cover and remove the battery. Wait about 10 seconds, then reinstall the battery. If desired, plug in the power cord. Turn on the printer.
- The printer may be plugged into a power strip that is turned off. Turn on the power strip, then turn on the printer.

The optional HP Photosmart Internal Battery is installed in the printer, but the printer will not turn on using battery power.

- The battery may need to be charged. Plug in the printer power cord to charge the battery. The On light flashes green to indicate that the battery is charging.
- If the battery is charged, try removing and reinstalling the battery.

The optional HP Photosmart Internal Battery is installed in the printer, but it will not charge.

- Open the battery compartment cover. Remove the battery and reinstall it. For more information on how to install the battery, see the documentation that came with the battery.
- Check that the printer power cord is securely connected to both the printer and the power source. When the printer is turned off, the On light flashes green to indicate that the battery is charging.
- Turn on the printer. The battery charging icon, a lightning bolt, flashes above the battery icon on the printer screen to indicate that the battery is charging.
- An empty battery should fully charge in approximately four hours when the printer is not in use. If the battery still does not charge, replace it.

The optional HP Photosmart Internal Battery low-power warning appears. I plug the printer into my automobile with the optional HP Photosmart Automobile DC Adapter, but the printer does not recognize the new power source.

- Turn the printer off before you plug the printer into the automobile with the adapter.
- Plug the printer into the automobile with the HP Photosmart Automobile DC Adapter.
- Turn the printer on.

The printer makes noises when I turn it on, or starts making noises on its own after it has been sitting unused for a while.

The printer may make noises after long periods of inactivity (approximately 2 weeks), or when its power supply has been interrupted and then restored. This is normal operation—the printer is performing an automatic maintenance procedure to ensure that it produces the best quality output.

Printing problems

Before contacting Customer Care, read this section for troubleshooting tips or go to the online support services at www.hp.com/support.

The printer does not print borderless photos when I print from the control panel.

The borderless printing option may be turned off. To turn on borderless printing, follow these steps:

1. Remove any memory cards from the memory card slots.



Caution Do not pull out a memory card while the Memory Card light is flashing.

2. Press **OK** on the control panel to display the printer menu.
3. Select **Preferences**, then press **OK**.
4. Select **Borderless**, then press **OK**.
5. Select **On**, then press **OK**.

Paper does not feed into the printer correctly.

- Make sure that the paper-width guide fits close to the edge of the paper without bending the paper.
- There may be too much paper loaded in the In tray. Remove some paper and try printing again.
- If sheets of photo paper stick together, try loading one sheet at a time.
- If you are using the printer in an extremely high or low humidity environment, insert the paper as far as it will go into the In tray, and load one sheet of photo paper at a time.
- If you are using photo paper that is curled, place the paper in a plastic bag and gently bend it in the opposite direction of the curl until the paper lies flat. If the

problem persists, use paper that is not curled. For information about proper storage and handling of photo paper, see [Maintaining the quality of photo paper](#).

- The paper may be too thin or too thick. Try using HP-designed photo paper. For more information, see [Choosing the right paper](#).

The photo printed at an angle or is off-center.

- The paper may not be loaded correctly. Reload the paper, making sure that the paper is correctly oriented in the In tray and that the paper-width guide fits close to the edge of the paper. For paper-loading instructions, see [Loading paper](#).
- The print cartridge may need to be aligned. For more information, see [Aligning the print cartridge](#).

No page came out of the printer.

- The printer may need attention. Read the printer screen for instructions.
- The power may be off or there may be a loose connection. Make sure that the power is on and the power cord is securely connected. If you are using battery power, make sure the battery is correctly installed.
- You may not have any paper in the In tray. Check that paper is loaded correctly in the In tray. For paper-loading instructions, see [Loading paper](#).
- The paper may have jammed while printing. See the following section for instructions on clearing a paper jam.

The paper jammed while printing.

Check the printer screen for instructions. To clear a paper jam, try the following:

- If the paper came part way through the front of the printer, gently pull the paper towards you to remove it.
- If the paper did not come part way through the front of the printer, try removing it from the back of the printer:
 - Remove the paper from the In tray, then pull down on the In tray to open it fully to a horizontal position.
 - Gently pull the jammed paper to remove it from the back of the printer.
 - Lift the In tray up until it snaps back into paper-loading position.
- If you cannot grasp the edge of the jammed paper to remove it, try the following:
 - Turn off the printer.
 - If the optional HP Photosmart Internal Battery is **not** installed in the printer, unplug the printer power cord. Wait about 10 seconds, then plug the power cord back in.
 - If the optional HP Photosmart Internal Battery is installed in the printer, unplug the printer power cord, if it is plugged in. Open the battery compartment cover and remove the battery. Wait about 10 seconds, then reinstall the battery. If desired, plug in the power cord.
 - Turn on the printer. The printer checks for paper in the paper path and will automatically eject the jammed paper.

Press **OK** to continue.



Tip If you experience paper jams while printing, try loading one sheet of photo paper at a time. Insert the paper as far as it will go into the In tray.

A blank page came out of the printer.

- Check the ink-level icon on the printer screen. If the print cartridge is out of ink, replace it. For more information, see [Inserting print cartridges](#).
- You may have begun printing and then cancelled the process. If you cancelled the process before the photo started printing, the printer may have already loaded paper in preparation for printing. The next time you print, the printer will eject the blank page before starting the new printing project.

The photo did not print using the printer's default print settings.

You may have changed the print settings for the selected photo. Print settings you apply to an individual photo override the printer's default print settings. Discard all print settings that have been applied to an individual photo by deselecting the photo. For more information, see [Selecting photos to print](#).

The printer ejects the paper when preparing to print.

Direct sunlight could be interfering with the operation of the automatic paper sensor. Move the printer out of direct sunlight.

Print quality is poor.

- The print cartridge may be running out of ink. Check the ink-level icon on the printer screen, and replace the cartridge if necessary. For more information, see [Insert the cartridge](#).
- You may have selected a low-resolution setting on the digital camera when you took the photo. For better results in the future, set the digital camera to a higher resolution.
- Make sure you are using the right type of photo paper for the project. Use HP-designed photo paper for best results. For more information, see [Choosing the right paper](#).
- You may be printing on the wrong side of the paper. Make sure the paper is loaded with the side to be printed facing up.
- The print cartridge may need to be cleaned. For more information, see [Cleaning the print cartridge](#).
- The print cartridge may need to be aligned. For more information, see [Aligning the print cartridge](#).

The photos I marked for printing in the digital camera do not print.

Some digital cameras, such as the HP 318 and HP 612, let you mark photos for printing both in the camera's internal memory and on the memory card. If you mark photos in the internal memory, and then move photos from the camera's internal memory to the memory card, the marks do not transfer. Mark photos for printing after you transfer them from the digital camera's internal memory to the memory card.

Bluetooth printing problems

Before contacting Customer Care, read this section for troubleshooting tips, or go to the online support services at www.hp.com/support. Be sure to also read the

documentation that came with your HP Bluetooth wireless printer adapter and your device with Bluetooth wireless technology.

My Bluetooth device cannot find the printer.

- Make sure the HP Bluetooth wireless printer adapter is plugged into the camera port on the front of the printer. The light on the adapter flashes when the adapter is ready to receive data.
- Bluetooth **Accessibility** may be set to **Not visible**. Change this setting to **Visible to all** as follows:
 - Remove any memory cards from the printer memory card slots.



Caution Do not pull out a memory card while the Memory Card light is flashing.

- Press **OK** to display the printer menu.
 - Select **Bluetooth**, then press **OK**.
 - Select **Accessibility**, then press **OK**.
 - Select **Visible to all**, then press **OK**.
- Bluetooth **Security level** may be set to **High**. Change this setting to **Low** as follows:
 - Remove any memory cards from the printer memory card slots.



Caution Do not pull out a memory card while the Memory Card light is flashing.

- Press **OK** to display the printer menu.
 - Select **Bluetooth**, then press **OK**.
 - Select **Security level**, then press **OK**.
 - Select **Low**, then press **OK**.
- The Passkey (PIN) that the device with Bluetooth wireless technology is using for the printer may be incorrect. Make sure the correct Passkey for the printer is entered in the device with Bluetooth wireless technology.
- You may be too far from the printer. Move the device with Bluetooth wireless technology closer to the printer. The maximum recommended distance between the device with Bluetooth wireless technology and the printer is 30 feet (10 meters).

No page came out of the printer.

The printer may not recognize the type of file sent by the device with Bluetooth wireless technology. For a list of the file formats that the printer supports, see [Printer specifications](#).

Print quality is poor.

The photo you printed may be low resolution. For better results in the future, set the digital camera to a higher resolution. Be aware that photos taken with VGA-resolution cameras, such as those found in wireless phones, may not have high enough resolution to produce a high-quality print.

The photo printed with borders.

The printing application installed on your device with Bluetooth wireless technology may not support borderless printing. Contact the vendor of the device, or go to their support website to obtain the latest updates for the printing application.

Error messages

Before contacting Customer Care, read this section for troubleshooting tips or go to the online support services at www.hp.com/support.

The following error messages may appear on the printer screen. Follow the instructions to resolve the problem.

Error message: Paper jam. Clear jam then press OK.

To clear a paper jam, try the following:

- If the paper came part way through the front of the printer, gently pull the paper towards you to remove it.
- If the paper did not come part way through the front of the printer, try removing it from the back of the printer:
 - Remove the paper from the In tray, then pull down on the In tray to open it fully to a horizontal position.
 - Gently pull the jammed paper to remove it from the back of the printer.
 - Lift the In tray up until it snaps back into paper-loading position.
- If you cannot grasp the edge of the jammed paper to remove it, try the following:
 - Turn off the printer.
 - If the optional HP Photosmart Internal Battery is **not** installed in the printer, unplug the printer power cord. Wait about 10 seconds, then plug the power cord back in.
 - If the optional HP Photosmart Internal Battery is installed in the printer, unplug the printer power cord, if it is plugged in. Open the battery compartment cover and remove the battery. Wait about 10 seconds, then reinstall the battery. If desired, plug in the power cord.
 - Turn on the printer. The printer checks for paper in the paper path and will automatically eject the jammed paper.
- Press **OK** to continue.

Error message: Automatic paper sensor failed.

The automatic paper sensor is obstructed or damaged. Try moving the printer out of direct sunlight, then press **OK** and try printing again. If this does not work, go to www.hp.com/support or contact Customer Care.

Error message: Cartridge is not compatible. Use appropriate HP cartridge.

Replace the print cartridge with one that is compatible with the printer. For more information, see [Inserting print cartridges](#).

Error message: Print cartridge cradle is stuck. Clear jam then press OK.

Follow these steps to clear any obstruction in the path of the print cartridge cradle:

1. Open the print cartridge door.
2. Clear any obstruction in the cradle path.
3. Close the print cartridge door, then press **OK** to continue.

Error message: Cartridge service station is stuck.

The print cartridge service station is the component located beneath the print cartridge cradle that wipes and caps the print cartridge for storage. Follow these steps to clear the obstruction blocking the print cartridge service station:

1. Open the print cartridge door.
2. Gently push the print cartridge and print cartridge cradle to the left to access the print cartridge service station.
3. Remove any obstruction.
4. Close the print cartridge door, then press **OK** to continue.

Error message: Memory card in backwards. The black side should face up.

A SmartMedia memory card has been inserted upside down. Gently pull the card out of the slot and reinsert it with the gold contacts facing down.

Error message: Photo is corrupted

While the printer was printing from a memory card, either another memory card was inserted or a USB device was connected to the front camera port. Insert only one memory card at a time. Do not insert a USB device while the printer is printing from a memory card. Your photo is not corrupted.

7 Specifications

This section lists the minimum system requirements for installing the HP Photosmart printer software, and provides selected printer specifications.

For a complete list of printer specifications and system requirements, see the onscreen Help. For information about viewing the onscreen Help, see [Welcome](#).

System requirements

Component	Windows PC minimum	Macintosh minimum
Operating system	Microsoft® Windows 98, 2000 Professional, ME, XP Home, and XP Professional	Mac® OS X 10.1 through 10.3
Processor	Intel® Pentium® II (or equivalent) or higher	G3 or greater
RAM	64 MB (128 MB recommended)	Mac OS 10.1 through 10.3: 128 MB
Free disk space	500 MB	500 MB
Video display	800 x 600, 16-bit or higher	800 x 600, 16-bit or higher
CD-ROM drive	4x	4x
Connectivity	USB 2.0 full-speed: Microsoft Windows 98, 2000 Professional, ME, XP Home, and XP Professional PictBridge: using front camera port Bluetooth: using optional HP Bluetooth wireless printer adapter	USB 2.0 full-speed: Mac OS X 10.1 through 10.3 PictBridge: using front camera port Bluetooth: using optional HP Bluetooth wireless printer adapter
Browser	Microsoft Internet Explorer 5.5 or later	—

Printer specifications

Category	Specifications
Connectivity	USB 2.0 full-speed: Microsoft Windows 98, 2000 Professional, ME, XP Home, and XP Professional; Mac OS X 10.1 through 10.3
Image file formats	JPEG Baseline TIFF 24-bit RGB uncompressed interleaved TIFF 24-bit YCbCr uncompressed interleaved TIFF 24-bit RGB packbits interleaved TIFF 8-bit gray uncompressed/packbits TIFF 8-bit palette color uncompressed/packbits TIFF 1-bit uncompressed/packbits/1D Huffman
Margins	Borderless printing: Top 0.0 inch (0.0 mm) ; Bottom 0.50 inch (12.5 mm); Left/right 0.0 inch (0.0 mm) Bordered printing: Top 0.16 inch (4 mm); Bottom 0.50 inch (12.5 mm); Left/right 0.16 inch (4 mm)
Media sizes	Photo paper 4 x 6 inch (10 x 15 cm) Photo paper with tab 4 x 6 inches with 0.5 inch tab (10 x 15 cm with 1.25 cm tab) Index cards 4 x 6 inches (10 x 15 cm) Hagaki cards 3.9 x 5.8 inches (100 x 148 mm) A6 cards 4.1 x 5.8 inches (105 x 148 mm) L-size cards 3.5 x 5 inches (90 x 127 mm) L-size cards with tab 3.5 x 5 inches with 0.5 inch tab (90 x 127 mm with 12.5 mm tab)
Media types	Paper (photo) Cards (index, Hagaki, A6, L-size)
Memory cards	CompactFlash Type I and II MultiMediaCard Secure Digital SmartMedia Memory Sticks xD-Picture Card
Memory card-supported file formats	Printing: All supported image and video file formats Saving: All file formats

(continued)

Category	Specifications
Operating temperature	32–113 degrees F (0–45 degrees C) [59–95 degrees F (15–35 degrees C) recommended]
Paper tray	One 4 x 6 inch (10 x 15 cm) photo paper tray
Paper tray capacity	20 sheets, maximum thickness 11.5 mil (292 µm) per sheet
Power consumption	U.S. Printing: 12.3 W Idle: 6.29 W Off: 4.65 W International Printing: 11.4 W Idle: 5.67 W Off: 4.08 W
Print cartridge	Tri-color (7 ml) HP #95 (North America, Latin America, Asia Pacific), #135 (Eastern Europe, Russia, Middle East, Africa, Japan), #343 (Western Europe), #855 (China, India) Tri-color (14 ml) HP #97 (North America, Latin America, Asia Pacific), #134 (Eastern Europe, Russia, Middle East, Africa, Japan), #344 (Western Europe), #857 (China, India) Gray Photo HP #100 (worldwide)
USB 2.0 full-speed support	Microsoft Windows 98, 2000 Professional, ME, XP Home, and XP Professional Mac OS X 10.1 through 10.3 HP recommends that the USB cable be less than 10 feet (3 meters) in length
Video file formats	Motion JPEG AVI Motion JPEG Quicktime MPEG-1
Power adapter	HP Part # Q3419-60040 (North America), 120 V HP Part # Q3419-60041 (Rest of world), 100-240 V

8 HP Customer Care

If you have a problem, follow these steps:

1. Check the documentation that came with the printer.
 - **Setup Guide:** The *HP Photosmart 320 series Setup Guide* explains how to set up the printer and print your first photo.
 - **User's Guide:** The *HP Photosmart 320 series User's Guide* is the book you are reading. This book describes the basic features of the printer, explains how to use the printer without connecting a computer, and contains hardware troubleshooting information.
 - **HP Photosmart Printer Help:** The onscreen HP Photosmart Printer Help describes how to use the printer with a computer and contains software troubleshooting information.
2. If you are unable to solve the problem using the information in the documentation, visit www.hp.com/support to do the following:
 - Access online support pages
 - Send HP an e-mail message for answers to your questions
 - Connect with an HP technician by using online chat
 - Check for software updatesSupport options and availability vary by product, country/region, and language.
3. Contact your local point of purchase. If the printer has a hardware failure, you will be asked to bring the printer to where you purchased it. Service is free during the printer limited warranty period. After the warranty period, you will be quoted a service charge.
4. If you are unable to solve the problem using the onscreen Help or HP websites, call HP Customer Care using the number for your country/region. For a list of country/region phone numbers, see the following section.

HP Customer Care by phone

While the printer is under warranty, you can obtain free phone support. For more information, see the warranty included in the box, or go to www.hp.com/support to check the duration of your free support.

After the free phone support period, you can obtain help from HP at an additional cost. Contact your HP dealer or call the support phone number for your country/region for support options.

To receive HP support by phone, call the appropriate support phone number for your location. Standard phone company charges apply.

North America: Call 1-800-HP-INVENT (1-800-474-6836). U.S. phone support is available in both English and Spanish languages 24 hours a day, 7 days a week (days and hours of support may change without notice). This service is free during the warranty period. A fee may apply outside the warranty period.



Note Customers in Western Europe should go to www.hp.com/support to access phone support numbers in their country/region.



61 56 45 43	الجزائر
Argentina Argentina	(54) 11-4778-8380 0-810-555-5520
Australia	13 10 47
800 171	البحرين
Brasil (dentro da grande São Paulo) Brasil (fora da grande São Paulo)	(11) 3747-7799 0800-157751
Canada	(800) 474-6836
Caribbean	1-800-711-2884
Central America	1-800-711-2884
Chile	800-360-999
中国	(8621) 38814518
Columbia	01-800-011-4726
Costa Rica	0-800-011-4114 + 1-800-711-2884
Česká republika	261 307 310
Ecuador (Andinatel)	1-800-711-2884
Ecuador (Pacifitel)	1-800-225528
2 532 5222	مصر
Greece (international) Greece (in-country) Greece (Cyprus)	+ 30 210 6073603 801 11 22 55 47 800 9 2649
Guatemala	1-800-999-5105
香港特別行政區	852-2802 4098
Magyarország	1 382 1111
India	1 600 44 7737
Indonesia	62 (21) 350 3408
(0) 9 830 4848	ישראל
Jamaica	0-800-7112884
日本	0570-000511
日本 (携帯電話の場合)	+81-3-3335-9800

한국	1588-3003
Malaysia	1800-80-5405
México (Ciudad de México) México (fuera de Ciudad de México)	(55)5258-9922 01-800-4726684
22 404747	المغرب
New Zealand	0800 441 147
Nigeria	1 3204 999
Panama	001-800-7112884
Perú	0-800-10111
Philippines	63 (2) 867-3551
Polska	22 5666 000
Puerto Rico	1-877-232-0589
Republica Dominicana	1-800-7112884
România	(21) 315 4442
Russia (Moscow) Russia (St. Petersburg)	095 7973520 812 3467997
800 897 1444	السعودية
Singapore	65 6272 5300
Slovakia	2 50222444
South Africa (Intl.) South Africa (RSA)	+ 27 11 2589301 086 0001030
Rest Of West Africa	+ 351 213 17 63 80
臺灣	(02) 8722-8000
Thailand	66 (2) 353 9000
71 89 12 22	تونس
Trinidad & Tobago	1-800-7112884
Türkiye	(212) 444 7171
Ukraine	(380 44) 4903520
800 4520	الإمارات العربية المتحدة
United States	(800) 474-6836
Venezuela	01-800-4746.8368
Việt Nam	84 (8) 823 4530
For Bangladesh, Brunei, Cambodia, Pakistan, and Sri Lanka	Fax to: +65-6275-6707

Placing a call

Call HP Customer Care while you are near the computer and printer. Be prepared to provide the following information:

- Printer model number (located on the front of the printer).
- Printer serial number (located on the bottom of the printer).
- Computer operating system.
- Version of printer driver:
 - **Windows PC:** To see the printer driver version, right-click the memory card icon in the Windows taskbar and select **About**.
 - **Macintosh:** To see the printer driver version, use the Print dialog box.

- Messages displayed on the printer screen or on the computer monitor.
- Answers to the following questions:
 - Has the situation you are calling about happened before? Can you recreate the situation?
 - Did you install any new hardware or software on your computer around the time that the situation occurred?

Return to HP repair service

HP will arrange to have your product picked up and delivered to an HP Central Repair Center. We pay for the round-trip shipping and handling. This service is free for the duration of the hardware warranty period.

a Installing the software

The printer comes with optional software you can install on a computer.

Windows users	Macintosh users
<p>Important: Do not connect the USB cable until you are prompted.</p> <p>HP Image Zone software and full printer functionality is installed automatically when you choose the Typical installation of your HP software.</p> <ol style="list-style-type: none">1. Insert the HP Photosmart CD into your computer's CD-ROM drive.2. Click Next and follow the onscreen instructions. If instructions do not appear, locate the setup.exe file on the CD-ROM drive and double-click it. Wait several minutes while the files load.3. When prompted, connect one end of the USB cable to the USB port on the back of the printer, and connect the other end to the USB port on your computer.4. Follow the onscreen instructions until the installation is finished and your computer restarts. When the Congratulations page appears, click Print a demo page.	<p>Important: Do not connect the USB cable until you are prompted.</p> <ol style="list-style-type: none">1. Insert the HP Photosmart CD into your computer's CD-ROM drive.2. Double-click the HP Photosmart CD icon.3. Double-click the HP Photosmart Install icon. Follow the onscreen instructions to install the printer software.4. When prompted, connect one end of the USB cable to the USB port on the back of the printer, and connect the other end to the USB port on your computer.5. Select the printer in the Print dialog box. If the printer does not appear in the list, click Edit Printer List to add the printer.

Index

- A**
 - accessories 7, 35
 - aligning print cartridges 16, 33
 - alignment page 33
 - automobile adapter 7, 35
- B**
 - batteries
 - charge indicator 5
 - compartment 6
 - model 7
 - black-and-white photos 14
 - Bluetooth
 - connecting to printer 29
 - troubleshooting 42
 - wireless printer adapter 7
 - borderless photos
 - do not print 40
 - print with borders 44
 - buttons 5
- C**
 - cameras
 - connecting to printer 29
 - photos do not print 42
 - port 4
 - printing from 25
 - carrying case
 - model 7
 - transporting printer 35
 - cartridges. *See* print cartridges
 - cleaning
 - print cartridge contacts 32
 - print cartridges 31
 - printer 31
 - CompactFlash 17
 - computer
 - connecting to printer 29
 - installing software 55
 - printing from 3
 - system requirements 47
 - control panel 5
 - Customer Care 51
- D**
 - digital cameras. *See* cameras
- Digital Flash 24
- documentation, printer 3
- E**
 - e-mailing photos 30
 - error messages 44
- F**
 - file formats, supported 18, 48
- H**
 - help. *See* troubleshooting
 - help, onscreen 3
 - HP direct-printing digital cameras 25
 - HP Instant Share 29, 30
 - HP iPod
 - how to print photos from 26
- I**
 - ink cartridges. *See* print cartridges
 - ink level, checking 6, 16, 32
 - inserting
 - memory cards 18
 - print cartridges 16
- J**
 - JPEG file formats 18
- L**
 - layout, selecting 24
 - lights 5
 - loading paper 14
- M**
 - memory cards
 - inserting 18
 - photos do not appear 38
 - printing from 25
 - removing 19
 - supported types 17
 - Memory Sticks 17
 - menu, printer 8
 - Microdrive 17
- MPEG-1 file format 18
- MultiMediaCard 17
- O**
 - onscreen Help 3
- P**
 - paper
 - buying and choosing 13
 - loading 14
 - maintaining 13, 35
 - specifications 48
 - trays 4
 - troubleshooting 40
 - photos
 - e-mailing 30
 - improving quality 24
 - index 22
 - print cartridges, choosing 14
 - printing 24
 - saving to computer 29
 - selecting for print 22
 - supported file formats 18
 - viewing 22
 - PictBridge cameras 25
 - print cartridges
 - aligning 33
 - choosing 14
 - cleaning 31
 - cleaning contacts 32
 - ink level, checking 16
 - inserting 16
 - replacing 16
 - storing 17, 34
 - testing 32
 - printer
 - accessories 7, 35
 - cleaning 31
 - connecting 29
 - documentation 3
 - error messages 44
 - menu 8
 - parts 4
 - power problems 39
 - specifications 48

- storing 34
- transporting 35
- warnings 2
- printing
 - from cameras 25
 - from computer 3
 - from memory cards 25
 - multiple copies 22
 - multiple photos 22
 - photo index 22
 - photos 24
 - selecting layout 24
 - test page 32
 - thumbnails 22
 - without computer 21

Q

- quality
 - photo paper 35
 - photos 24
 - print 25
 - printing test page 32
 - troubleshooting 42

R

- regulatory notices 59
- removing memory cards 19
- replacing print cartridges 16

S

- saving photos to computer 29
- Secure Digital 17
- Smart Focus 24
- SmartMedia 17
- software, installing 55
- specifications 47
- storing
 - photo paper 35
 - print cartridges 17, 34
 - printer 34
- system requirements 47

T

- test page 32
- thumbnails, printing 22
- TIFF file format 18
- transporting printer 7, 35
- trays, paper 4
- troubleshooting
 - Bluetooth 42
 - borderless photos 40
 - buttons do not work 38

- cannot find photos 38
- Customer Care 51
- error messages 44
- flashing lights 37
- paper problems 40
- power problems 39
- printer noises 40
- quality problems 42

U

- USB
 - connection type 29
 - port 4
 - specifications 48

V

- video clip
 - how to print frames from 23
 - icon on printer screen 6
 - supported file formats 18, 49
- viewing photos 22

X

- xD-Picture Card 17

Regulatory notices

Hewlett-Packard Company

This device complies with part 15 of the FCC Rules. Operation is subject to the following two conditions:

- This device may not cause harmful interference, and
- This device must accept any interference received, including interference that may cause undesired operation.

Pursuant to Part 15.21 of the FCC Rules, any changes or modifications to this equipment not expressly approved by Hewlett-Packard Company may cause harmful interference, and void your authority to operate this equipment. Use of a shielded data cable is required to comply with the Class B limits of Part 15 of the FCC Rules.

For further information, contact: Hewlett-Packard Company, Manager of Corporate Product Regulations, 3000 Hanover Street, Palo Alto, CA 94304, (650) 857-1501.

Note

This equipment has been tested and found to comply with the limits for a Class B digital device, pursuant to part 15 of the FCC rules. These limits are designed to provide reasonable protection against harmful interference in a residential installation. This equipment generates, uses, and can radiate radio frequency energy and, if not installed and used in accordance with the instructions, can cause harmful interference to radio communications. However, there is no guarantee that interference will not occur in a particular installation. If this equipment does cause harmful interference to radio or television reception, which can be determined by turning the equipment off and on, the user is encouraged to try to correct the interference by one or more of the following measures:

- Reorient or relocate the receiving antenna.
- Increase the separation between the equipment and the receiver.
- Connect the equipment into an outlet on a circuit different from that to which the receiver is connected.
- Consult the dealer or an experienced radio/TV technician for help.

LED indicator statement

The display LEDs meet the requirements of EN 60825-1.

사용자 안내문 (한국 기기)

이 기기는 비업무용으로 전자파장애검정을 받은 기기여서, 주거지역에서는 다른 모든 지역에서 사용될 수 있습니다.

この装置は、情報処理装置等電波障害自主規制協議会（VCCI）の基準に基づくクラスB情報技術装置です。この装置は、家庭環境で使用することを目的としていますが、この装置がラジオやテレビジョン受信機に近接して使用されると受信障害を引き起こすことがあります。
取り扱い説明書に従って正しい取り扱いをして下さい。