



HTC Vive PRE (Developer Edition)



Contents

Unboxing

About Vive	4
Vive headset	4
Link box	10
Vive controllers	11
Vive base stations	13

Getting started

Setting up Vive for the first time	16
What is the play area?	16
Choosing the play area	16
Setting up the play area	17
Exploring Vive	19

Troubleshooting and FAQs

General	21
Tracking	22
Setup	22

Trademarks and copyrights

Confidential
For review only

About this guide

In this user guide, we use the following symbols to indicate useful and important information:



This is a note. A note often gives additional information, such as what happens when you choose to do or not to do a certain action. A note also provides information that may only be applicable to some situations.



This is a tip. A tip gives you an alternative way to do a particular step or procedure, or lets you know of an option that you may find helpful.



This indicates important information that you need in order to accomplish a certain task or to get a feature to work properly.



This provides safety precaution information, that is, information that you need to be careful about to prevent potential problems.

Confidential
For review only

Unboxing

About Vive

With Vive™, you can look and move around a room-scale virtual environment. Because your physical location is tracked, you can explore and interact within immersive fantasy worlds.

About Vive PRE (Developer Edition)

Vive PRE includes the headset, controllers, and base stations that you need to start creating interactive VR experiences.

⚠ In-box items may vary from the consumer version. Do not disassemble any of the hardware as it could injure you or damage the product.

Vive headset

The headset is your window to the VR environment.

⚠ Do not cover the sensors on the headset as these are tracked by the base stations.

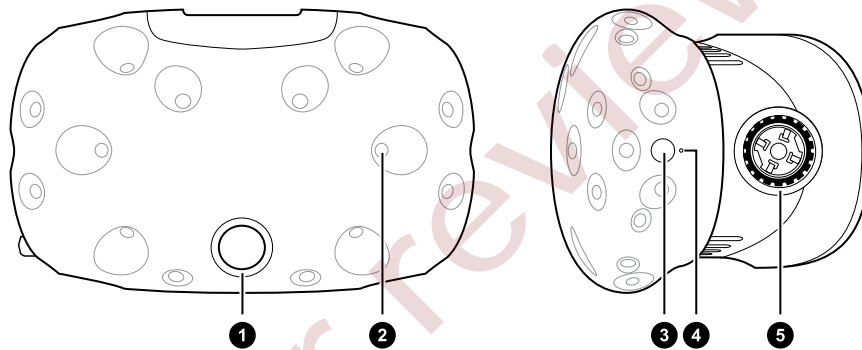

1	Camera lens
2	Tracking sensor
3	Camera button
4	Status light
5	Lens distance knob

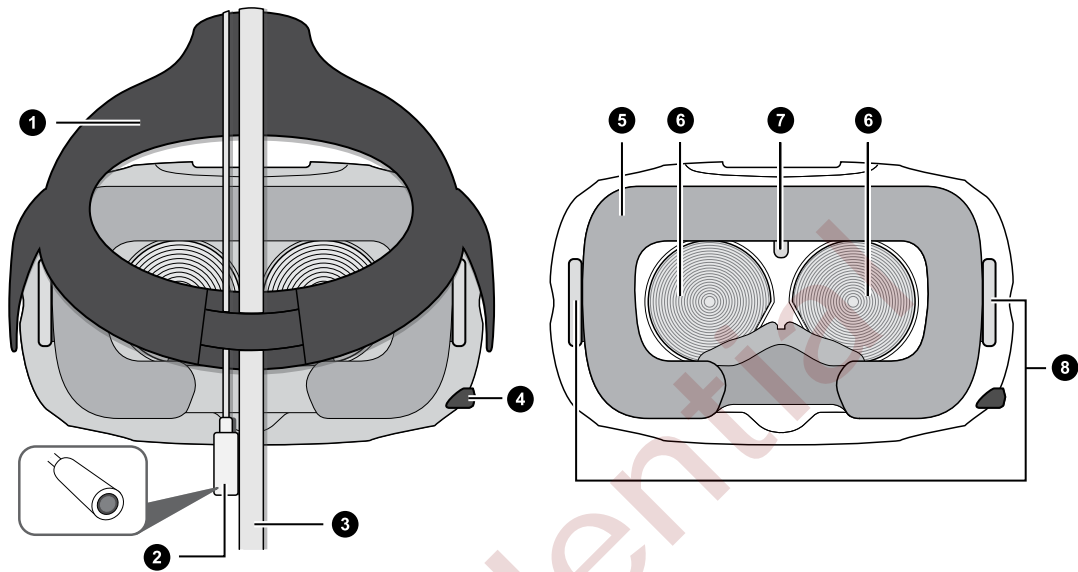

1	Strap
2	Audio cable
3	3-in-1 headset cable
4	IPD (interpupillary distance) knob
5	Face cushion
6	Lenses
7	P-sensor
8	Lens distance knobs



- Only use the cleaning cloth provided in the box to wipe the lenses.
- Do not cover the P-sensor.

Putting the headset on

1. Pull the headset down over your eyes.
2. Slide the straps around the back of your head, and adjust them so that the headset fits snugly and comfortably.

Adjusting the lens distance on the headset

The closer the lenses are to your eyes, the better the field of view.



If you need to wear prescription glasses while using Vive, adjust the lens distance for space to fit your glasses in.

1. Pull out each lens distance knob to unlock it.

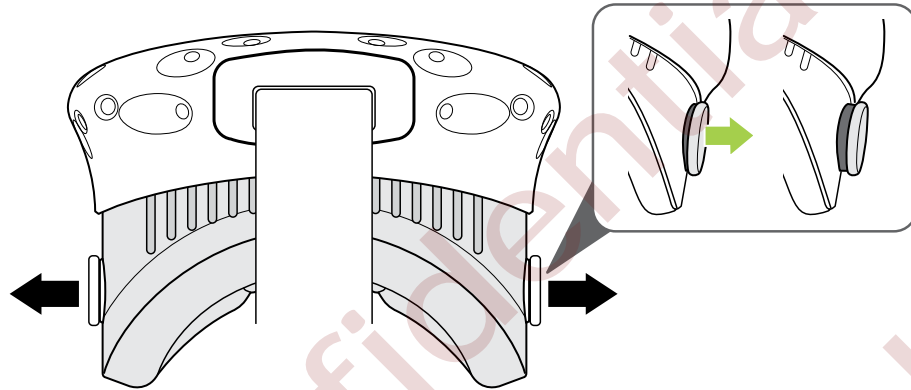

2. Rotate both lens distance knobs to adjust the lens further or closer to your face.

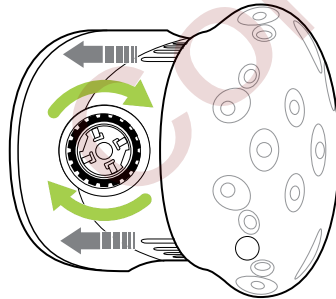

3. After you're done adjusting, push each knob to lock it back in.

Using the IPD knob on the headset

Interpupillary distance (IPD) is the distance between the center of the pupils in your eyes. A quick way to get an estimate is by facing a mirror and holding a millimeter ruler against your brow. Use this measurement as a guide to adjust the distance between the lenses of the headset so that you'll have a better viewing experience.

To change the distance between the lenses, rotate the IPD knob.

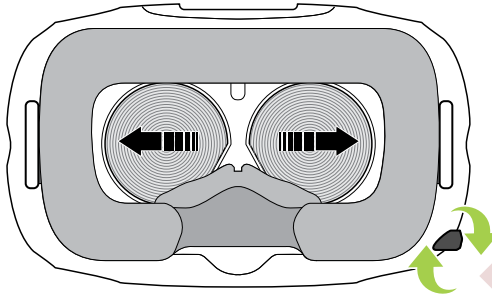

As you adjust the IPD, you'll see information about the current distance between the lenses.

Confidential
For review only

Connecting a USB device to the headset

Plug in the USB 3.0 cable to the headset for using a compatible third-party device with Vive.

1. Push open the compartment cover to access the connector slots on the headset.

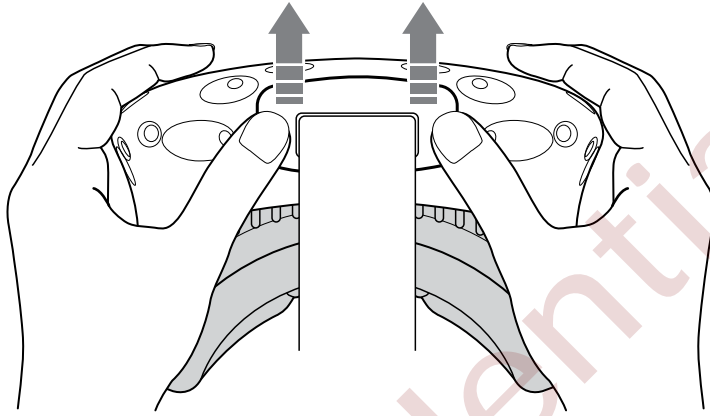

2. Plug in the USB cable to its corresponding slot.

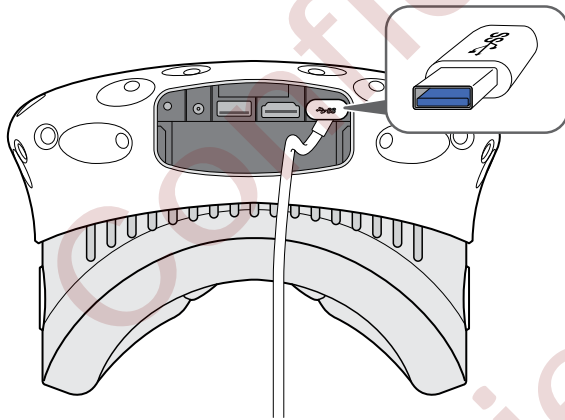

3. Connect the third-party device to the USB cable end.

For review only

Cleaning or replacing the face cushion

Remove the face cushion to clean sweat or makeup stains from the foam or to replace it with the spare face cushion that comes in the box.

1. To remove the face cushion, peel off the foam starting from both ends of the face cushion until it detaches from the headset.

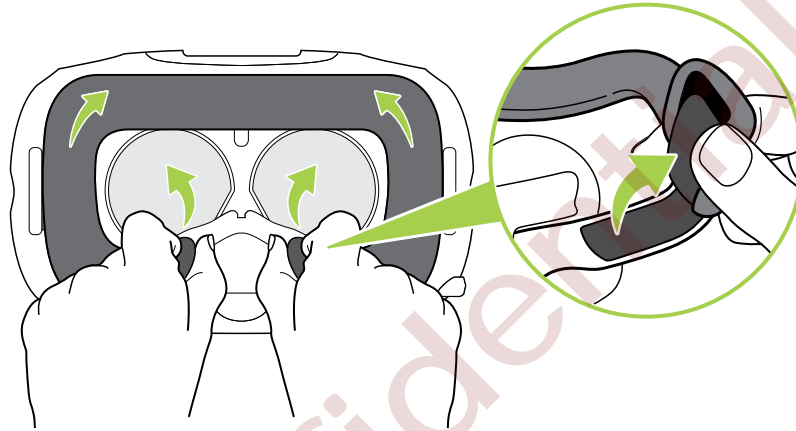

2. When cleaning the face cushion, hand wash with water or use toning lotion to remove makeup stains. Do not scrub, bleach, iron, or tumble dry.
3. To replace the face cushion, attach the adhesive strip to the frame on the headset.

Headset status light

The status light shows:

- White when the headset is active
- Flashing white when the headset is not tracked
- Flickering white when the headset is on standby
- Red when an error is encountered (with cables, display, or the like)

Link box

Use the link box to connect the headset to your computer.

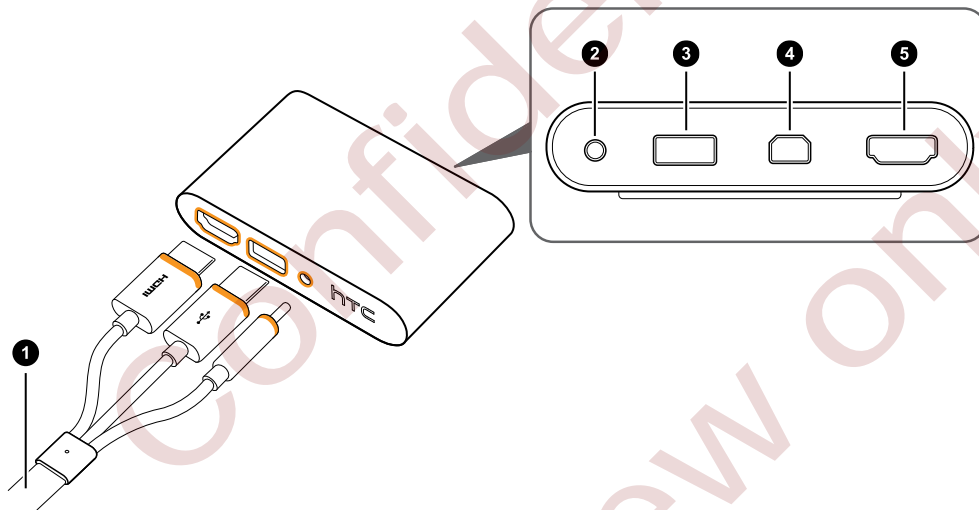

1 3-in-1 cable

2 Power port

3 USB port

4 Mini DisplayPort™

Note: Cable is not provided. Use if your computer doesn't support HDMI.

5 HDMI port

Connecting the headset to your computer

1. Connect the power adapter cable on its corresponding port on the link box, and then plug the opposite end into an electrical outlet to turn the link box on.
2. Insert the HDMI cable on the HDMI port on the link box, and then insert the opposite end on the HDMI port on your computer's graphic card.

3. Insert the USB cable on the USB port on the link box, and then insert the opposite end on your computer's USB port.
4. Connect the 3-in-1 headset (HDMI, USB, and power) cables on the side with matching orange trims on the link box.

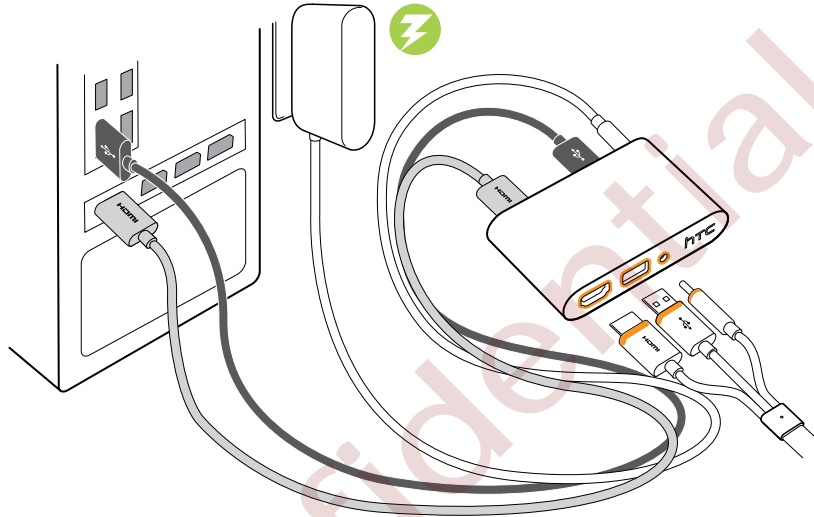

Vive controllers

Use the controllers to interact with objects in the VR world.



Do not cover the sensors on the controllers as these are tracked by the base stations.

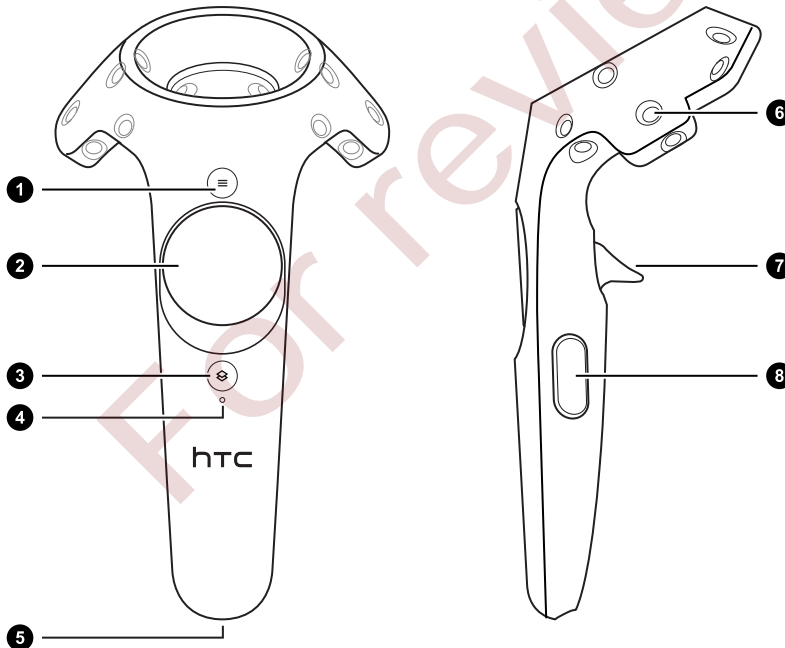

1	Menu button
2	Trackpad
3	System button
4	Status light
5	USB charging adapter
6	Tracking sensor
7	Trigger
8	Grip button

Charging the controllers

Charge each controller using the USB cable provided.

The status light shows a solid white when the controller is fully charged.

Turning the controllers on or off

- To turn the controller on, press the System button until you hear a beeping sound.
- To turn the controller off, press and hold the System button until you hear a beeping sound.

Attaching the lanyards to the controllers

Using the lanyards may help prevent the controllers from accidentally being dropped.

1. While holding the controller, insert the lanyard's thread from the top to the bottom hole.
2. Loop the lanyard through the thread, and then tug the lanyard to fasten it in place.
3. Place the lanyard on your wrist, and then adjust the lock to tighten the lanyard comfortably around your wrist.

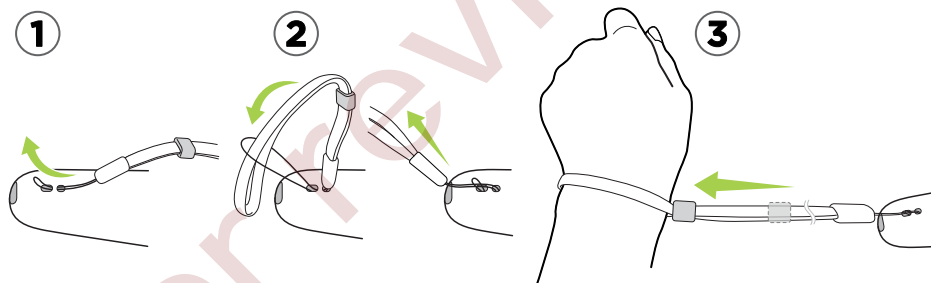

Pairing the controllers with the headset

- Once the controllers are turned on, they will automatically pair with the headset.

The status light shows as blinking blue while the pairing is in progress. The status light turns solid white when the controllers are paired with the headset.

- If the pairing is somehow lost, manually pair the controllers with the headset by pressing the System and Menu buttons at the same time.

Controller status light

The status light shows:

- White when the controller is active
- Flashing white when the controller is not tracked
- Red when an error is encountered
- Flashing red when battery is low
- Flashing blue when the controller is pairing with the headset
- Blue when the controller is connecting with the headset
- Orange when charging

Vive base stations



The base stations track sensors from the headset and controllers. Do not cover the LED lens with any material.



If the LED lens are cracked or damaged, stop using the base stations. Please call Vive customer service for instructions.

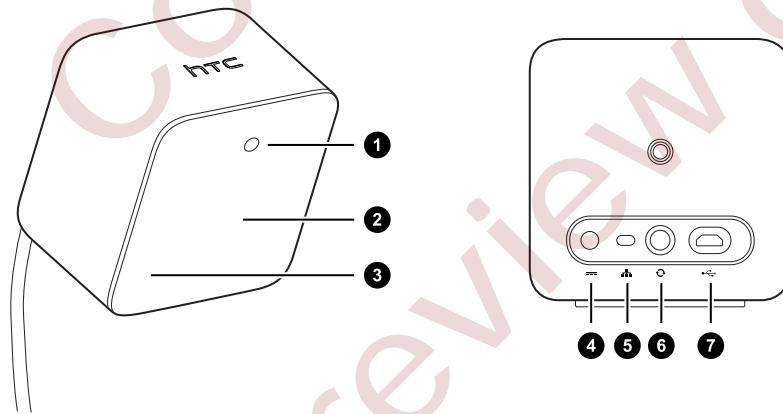

1	Status light
2	LED lens
3	Channel indicator
4	Power port
5	Channel button
6	Sync cable port
7	Micro USB port

Note: Use this for firmware updates.



When the base stations are turned on, it may affect some nearby infrared sensors, such as those used by an IR TV remote control.

Installing the base stations



Do not attempt to pry open the base stations as it could injure you or damage the product.

1. Place the base stations on opposite sides of the room on a spot that's above your height. It's recommended to mount the base stations on a high shelf, tripod, or on a ceiling or wall.



Avoid using unstable mounting accessories or surfaces that are prone to vibration.



2. Make sure that the base stations are facing toward the center of the play area. It is recommended that they are angled down between 30 to 45 degrees.

3. Attach the power cables to each base station, and then plug them into a power outlet. The status light should show as white.
4. Connect the base stations and set the channel.
 - With the sync cable (recommended). One base station needs to be set to “A” channel, while the other is set to “B” channel.

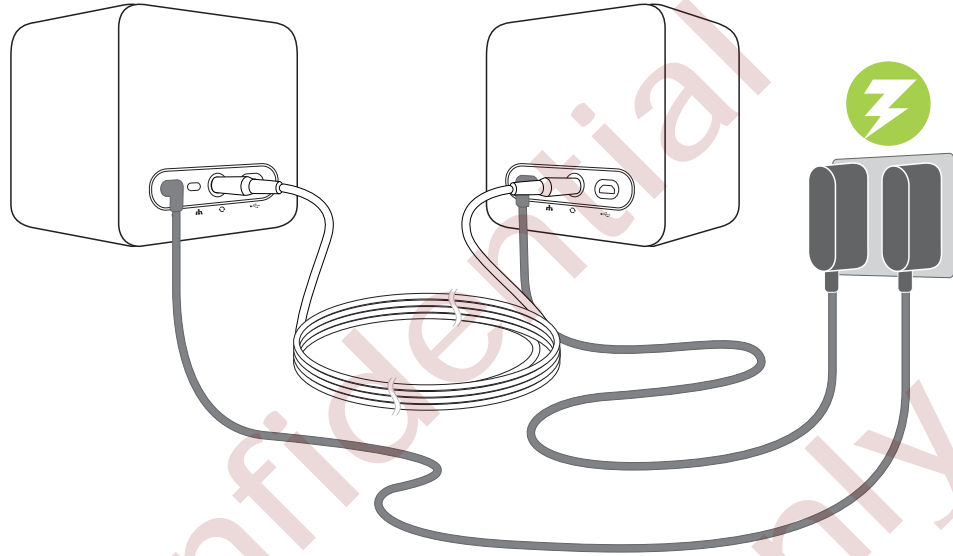

- Without the sync cable. One base station needs to be set to “B” channel, while the other is set to “C” channel.

To configure the channel, do the following:

- a) Press and hold the Channel button to change the channel.
- b) Press the Channel button to toggle between channels.
- c) Press and hold the Channel button again to set the channel.

Base station status light

The status light shows:

- White when the base station is active
- Flashing white when the base station is on standby
- Red when an error is encountered (with the laser, motor, or the like)

Getting started

Setting up Vive for the first time

Before you can use Vive, you'll need to set it up. Walk through the setup process to install software, set up hardware, define your play area, and more.



Make sure to sign in with your HTC Account to download exclusive VR content.

To begin, download the Vive Setup file from www.htcvive.com.

What is the play area?

The play area sets the virtual boundaries of Vive. Your interaction with VR objects happen within the play area.

Choosing the play area

Find a space that you will designate as the play area. For best results, do the following:

- Clear the play area of furniture and other things (including pets) that may block you from freely moving around.

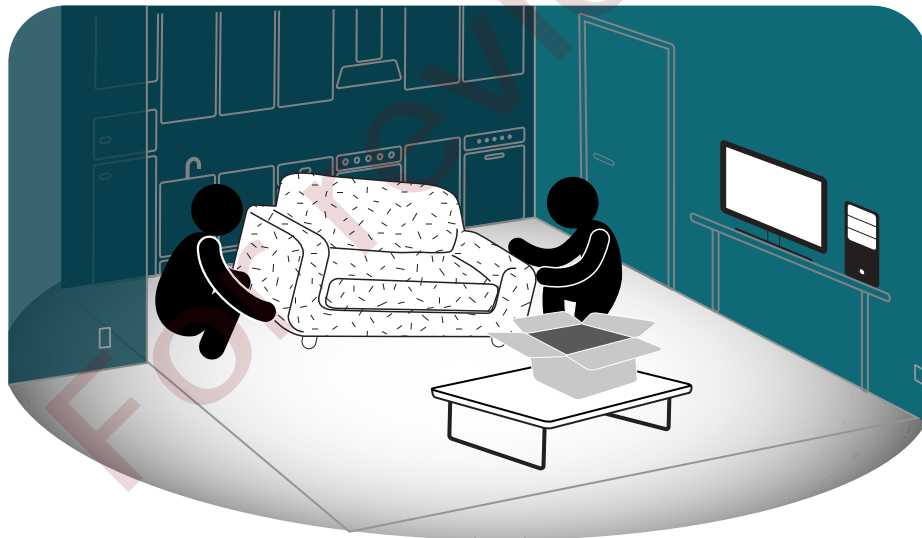

- Remove or cover mirrors or reflective surfaces.
- Cover windows or other sources of direct sunlight.

- If you're planning to set up room-scale VR, choose a space that has a minimum play area of around 6.5 x 5 feet (2 x 1.5 meters).
- Place your computer right outside of this space. The headset cable can only extend by around 16 feet (5 meters) from your computer.

Setting up the play area

During the Vive setup process, you'll be prompted to set the bounds of the play area.



When tracing the boundaries of the play area, make sure that the floor is cleared. Do not trace across space occupied by things (such as a table or a chair) since this may cause you to trip or slam into the object while in VR.

Setting up a room-scale play area

Choose a room-scale play area if your space has a minimum play area of around 6.5 x 5 feet (2 x 1.5 meters).

1. On the Room Setup's Welcome screen, click **Room-scale**.
2. Review the prompts, and then click **Next**.
3. When prompted, stand in the middle of the play area and face the computer monitor.
4. Press and hold the controller's trigger, and then click **Next**.
5. Place both controllers on the floor, click **Calibrate floor**, and then click **Next**.
6. When prompted to measure the room's available space, click **Next**.
7. Holding one controller, press and hold the trigger and walk and trace the boundaries of your room.



You can also click **Advanced mode**. To define the room's available area, click the trigger at each corner of the room.

You'll see that your steps are being mapped. If you want to start over, release the trigger, and then press it again.

8. Keep walking until you've returned to your starting point. When the borders of your available space have been defined, click **Next**.
9. On your computer, click **Edit**, and then drag the edges of the play area (the green area) to change its size.



If the play area shows as red, you need to adjust it so that it fits within the available space.

10. Click **Done** to save the setup.

Setting up a standing-only play area

Choose this option if you only want to experience VR in a seated or standing position.

1. On the Room Setup's Welcome screen, click **Standing only**.
2. Place the headset where it's visible from the base stations, and then click **Next**.
3. Stand in the middle of the cleared space while facing the default direction you want to use Vive, click **Calibrate center**, and then click **Next**.
4. Place the headset on a stable surface visible from the base stations and then enter the distance between the surface and the floor below. You can also place your headset on the floor and put 0 as distance.
5. Click **Calibrate floor**, and then click **Next**.
6. Click **Done** to save the setup.

Confidential
For review only

Exploring Vive

Once you've completed the Vive setup process, you can now wear the headset and hold the controllers.

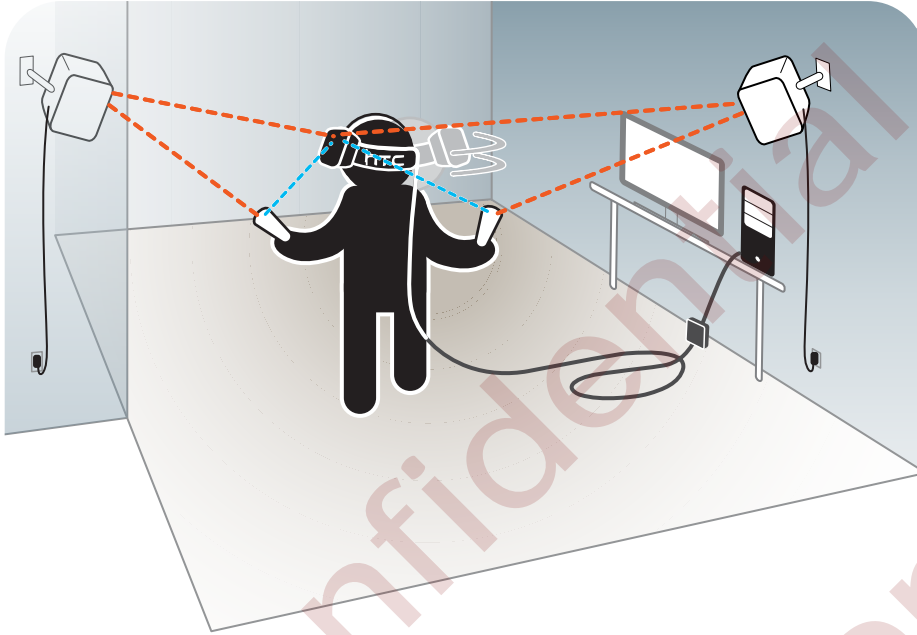

For health and safety warnings, please refer to the Safety and regulatory guide, which is periodically updated for accuracy and completeness. For the latest version, check www.htcvive.com.

System Dashboard

Download VR apps, change your settings, and more on the System Dashboard.

To go to the System Dashboard, press the System button on any of your controllers upon wearing the headset or while using any VR app.

You can:

- Switch to the Vive tab, where you can launch Vive Home. Point the controller at the Vive tab, and then press the trigger.
- View your immediate surroundings outside the VR. With the controller in front of the headset, you'll see a small window that shows your actual room.

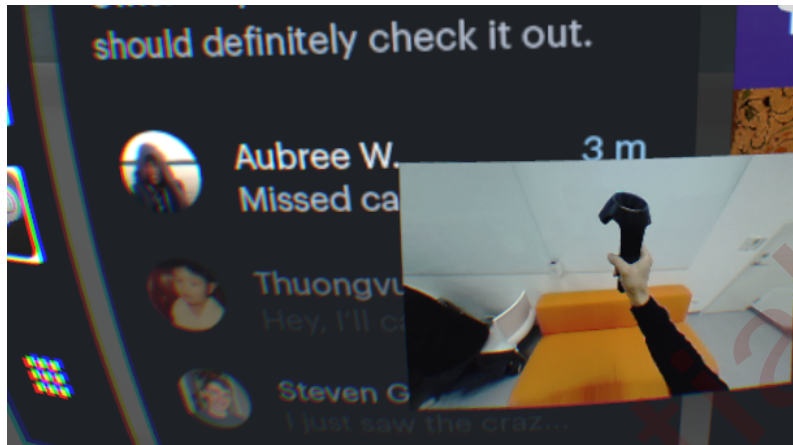

Vive tab

The Vive tab on the System Dashboard offers you an entry point to VR services.

Press the System button on the controller to show the dashboard, and then switch to the Vive tab.

Use the Vive tab to:

- Launch Vive Home by selecting 
- Check out featured and recommended VR apps
- Sort and view your recently opened VR apps
- Open a VR app
- Access services from your phone

Vive Home

Vive Home is your own personal VR space.

More than a scenic background, some of the things you can do on Vive Home are:

- Move around the virtual environment. You can also go to another part of the scene by pointing your controller to a spot, and then pressing the trackpad.
- Add shortcuts
- Collect and interact with gadgets

Press the Menu button on the controller to show the Vive menu, where you can change to another Home space, among other options.

Vive desktop app

Open Vive on your computer to:

- Check out featured and recommended VR apps
- Download or browse VR apps from HTC
- Change Vive settings, including hardware and account settings

Troubleshooting and FAQs

General

What can I do when the status light on the headset indicates an error?

If you see that the status light is red, try these methods to resolve the issue:

- Disconnect and reconnect the headset 3-in-1 cable on the link box.
- Check that the cables between the link box and your computer are properly connected.
- Unplug and replug the power adapter into an electrical outlet to restart the link box.

What can I do if the headset display is blank, and the Vive display is shown on the computer monitor instead?

Try the following steps to troubleshoot the issue:

1. From your computer monitor, open the Control Panel.
2. In Category view, click **Hardware and Sound > Display > Change display settings**.
3. On the Multiple displays drop-down list, select **Extend these displays**.

What can I do if the headset is set as the main computer display?

When the headset has higher resolution than the LCD monitor, some computers automatically make the headset as the main computer display. Try the following steps to troubleshoot the issue:

1. While wearing the headset, use your computer mouse to navigate and open the computer's Control Panel.
2. In Category view, click **Hardware and Sound > Display > Change display settings**.
3. On the Multiple displays drop-down list, select **Extend these displays**.

What can I do when status lights on base stations indicate an error?

A common reason why the status light turns red is when the base stations are shaken. This causes the base stations to temporarily disable tracking. Avoid using unstable mounting accessories or surfaces that are prone to vibration.

What should I do if Vive hardware and SteamVR app statuses are not in sync?

If the statuses are different between Vive hardware and the SteamVR app during the setup process or normal use, do the following:

1. Close all Steam apps on your computer, including the SteamVR app.
2. Restart the SteamVR app.

Tracking

One or more Vive hardware are not tracked. What should I do?

Make sure that the hardware are placed inside the play area. You can also turn the hardware off and on again to reactivate the tracking.

If you're having an issue with the headset, you can try to disconnect and reconnect the HDMI cable to the HDMI port on your computer's graphic card.

If you still get an error, restart your computer and reopen the SteamVR app.

How do I know which of the controllers is not being tracked?

If one of your controllers is not being tracked and you want to find out which one, follow these steps.

1. On your computer, open the SteamVR app.
2. Hover your cursor on the icon of the controller that's not tracked.
3. Click **Identify controller**.

The controller will vibrate and its status light will show a rapid flashing white.

When Vive is in use, my TV remote isn't working. What can I do?

The base stations may affect some nearby infrared sensors, such as those used by an IR TV remote control.

1. Re-adjust the angle of the base stations so that they are not directly facing your TV.
2. Verify that your remote control is working without interference from Vive.
3. Set up the play area again. For more information, see [Setting up the play area](#) on page 17.

Setup

How do I reset the play area?

1. On your computer, open the SteamVR app.
2. Click the drop-down arrow, and then select **Run Room Setup**.
3. Follow the prompts to complete the process.

Trademarks and copyrights

©2016 HTC Corporation. All Rights Reserved.

HTC, the HTC logo, Vive, the Vive logo, and all other HTC product and services names are the trademarks or registered trademarks of HTC Corporation and its affiliates in the U.S. and other countries.

SteamVR is a trademark of Valve Corporation.

All other trademarks and service marks mentioned herein, including company names, product names, service names and logos, are the property of their respective owners and their use herein does not indicate an affiliation with, association with, or endorsement of or by HTC Corporation. Not all marks listed necessarily appear in this User Guide.

Screen images contained herein are simulated. HTC shall not be liable for technical or editorial errors or omissions contained herein, nor for incidental or consequential damages resulting from furnishing this material. The information is provided “as is” without warranty of any kind and is subject to change without notice. HTC also reserves the right to revise the content of this document at any time without prior notice.

No part of this document may be reproduced or transmitted in any form or by any means, electronic or mechanical, including photocopying, recording or storing in a retrieval system, or translated into any language in any form without prior written permission of HTC.