

User guide

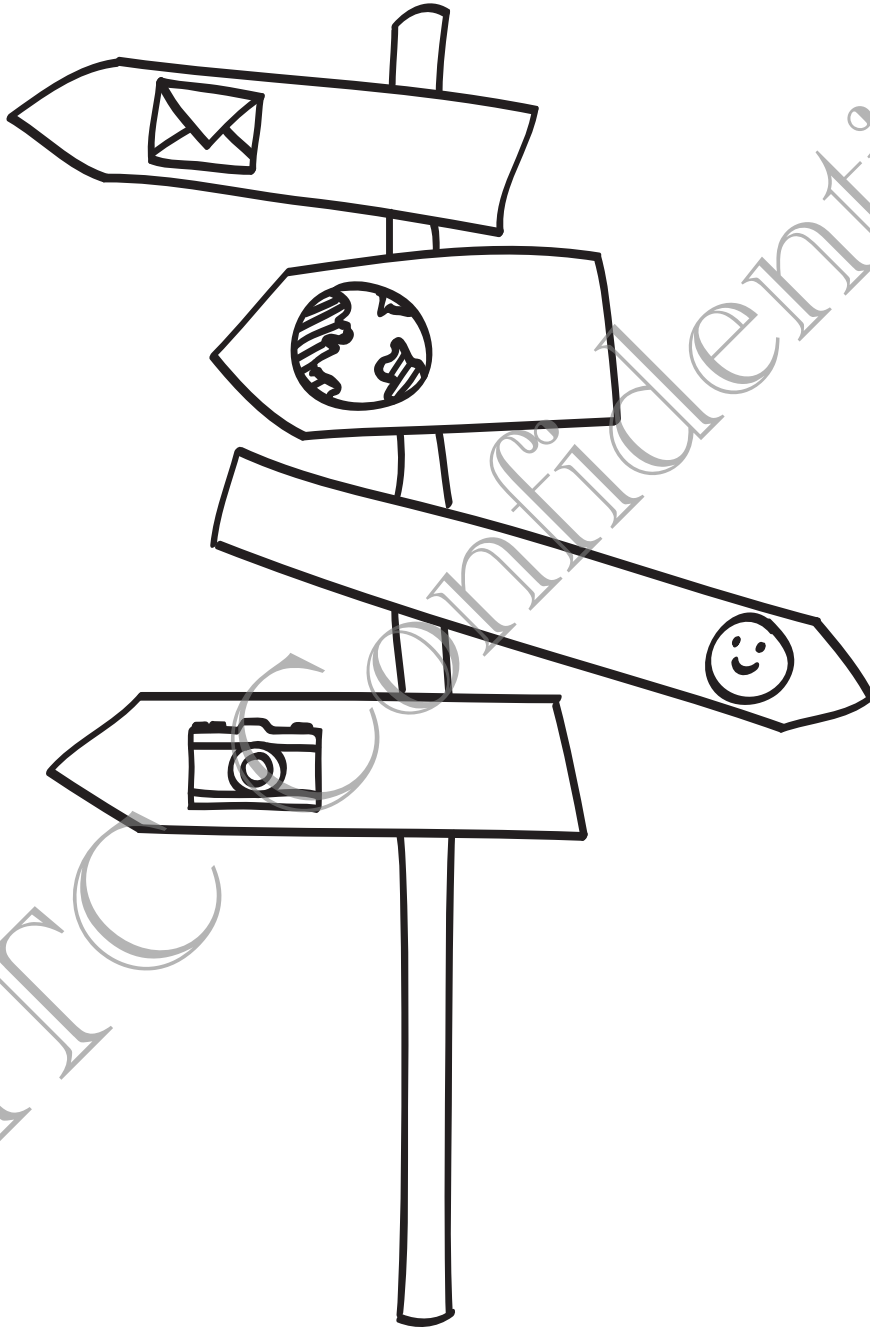

HTC

htc
quietly brilliant

Contents

Getting started	8
Inside the box	8
Your phone	8
Back cover	10
SIM card	11
Storage card	12
Battery	13
Switching your phone on or off	15
Entering your PIN	15
Finger gestures	15
Setting up your phone for the first time	16
Ways of getting contacts into your phone	16
Home screen	17
Basics	18
Adjusting the volume	18
Sleep mode	19
Status and notifications	20
Notifications panel	22
Connecting your phone to a computer	24
Copying files to or from the storage card	24
Copying text, looking up information, and sharing	25
Personalizing	27
Making your phone truly yours	27
Personalizing your phone with scenes	27
Changing your wallpaper	28
Applying a new skin	29
Personalizing your Home screen with widgets	29
Adding icons and other shortcuts on your Home screen	31
Adding folders on your Home screen	31
Rearranging or removing widgets and icons on your Home screen	32
Rearranging the Home screen	32
Using sound sets	33
Changing your ringtones and alarms	34
Rearranging or hiding application tabs	35
Phone calls	36
Different ways of making calls	36
Making a call on the Phone dialer screen	36
Using Speed dial	37
Calling a phone number in a text message	37
Calling a phone number in an email	38
Making an emergency call	38
Receiving calls	39
What can I do during a call?	40
Setting up a conference call	42
Internet calls	42

3 Contents

Using Call history	43
Using Home dialing	44
Call services	45
Turning Airplane mode on or off	46
Messages	47
Opening Messages	47
Sending a text message (SMS)	47
Sending a multimedia message (MMS)	48
Resuming a draft message	50
Viewing and replying to a message	50
Viewing and saving an attachment from a multimedia message	51
Push messages	52
Managing message conversations	52
Setting message options	54
People	55
Transferring contacts from your old phone	55
About the People app	56
Setting up your profile	57
Importing contacts from your SIM card	58
Adding a new contact	58
Importing a contact from an Exchange ActiveSync account	58
Merging contact information	59
Filtering your contacts list	60
Backing up your contacts to the storage card	61
Contact information and conversations	61
Sending contact information as a vCard	62
Contact groups	63
Adding People widgets	65
Email	67
Gmail	67
Mail	69
Calendar	75
About Calendar	75
Creating an event	75
Changing Calendar views	77
Managing Calendar events	78
Dismissing or snoozing event reminders	79
Displaying and synchronizing reminders	80
Changing Calendar settings	81
About the Calendar widget	81
Search and Web browser	82
Searching your phone and the web	82
Using your phone's web browser	83
Downloading from the Web	86
Viewing bookmarks and previously visited pages	86
Setting browser options	88

Camera	89
Camera basics	89
Taking a photo	90
Recording video	91
Adding effects	92
After capturing	92
Changing camera settings	93
Photos, videos, and music	94
Gallery	94
Music	101
Connected Media	107
Accounts and sync	109
About online accounts	109
Synchronizing with a Google Account	109
Adding a social network account	110
Managing your online accounts	110
Social	112
Facebook for HTC Sense	112
Facebook app	113
Tweeting on your phone using Peep	114
Using Friend Stream	116
Chatting in Google Talk	119
Maps and location	121
Location settings	121
Locations	121
Google Maps	130
Market and other apps	133
Finding and installing apps from Android Market	133
Using the Clock	135
Checking Weather	137
Reading eBooks	139
Reading news feeds	141
Keeping track of your stocks	143
Working on documents, spreadsheets, and presentations	144
Watching videos on YouTube	145
Listening to FM Radio	146
Recording your voice	147
Using Flashlight	148
Sharing games and apps	148
HTC Sync	149
About HTC Sync	149
Installing HTC Sync that came with the storage card	150
Setting up HTC Sync to recognize your phone	150
Getting to know the workspace	151
Setting up synchronization	151

Synchronizing your phone	154
Installing an app from your computer to your phone	154
Synchronizing another phone with your computer	155
Downloading the latest HTC Sync upgrade	155
HTCSense.com	156
Signing up for your HTCSense.com account	156
Using HTCSense.com	156
Deleting your HTCSense.com account	158
Keyboard	159
Using the onscreen keyboard	159
Entering words with predictive text	160
Entering text by speaking	162
Editing text	163
Adjusting input settings	164
Internet connections	165
Data connection	165
Wi-Fi	166
About connection widgets	168
Connecting to a virtual private network (VPN)	168
Using your phone as a modem (USB tethering)	169
Connecting your phone to the Internet through a computer (Internet Pass-through)	170
Using your phone as a wireless router	170
Bluetooth	171
Bluetooth basics	171
Connecting a Bluetooth headset or car kit	171
Disconnecting or unpairing from a Bluetooth device	172
Sending information using Bluetooth	173
Receiving information using Bluetooth	174
Security	176
Protecting your SIM card with a PIN	176
Protecting your phone with a screen lock pattern, PIN or password	177
Settings	178
Settings on your phone	178
Changing display settings	179
Changing sound settings	181
Changing the phone language	182
Optimizing your phone's battery life	182
Managing memory	183
Checking information about your phone	184
Update and reset	185
Phone software updates	185
Restarting your phone	186
Resetting your phone	186

Trademarks and copyrights	187
Index	188

HTFC Confidential

Conventions used in this guide

In this user guide, we use the following symbols to indicate useful and important information:



This is a note. A note often gives additional information, such as what happens on your phone when you choose to do or not to do a certain action. A note also provides information that may only be applicable to some situations.



This is a tip. A tip gives you an alternative way to do a particular step or procedure, or lets you know of an option that you may find helpful.



This indicates important information that you need in order to accomplish a certain task or to get a phone feature to work properly.



This provides safety precaution information, that is, information that you need to be careful about to prevent potential problems when using your phone.

HTFC Confidential

Getting started

Inside the box

You will find the following inside the box:

- Phone
- Battery (preinstalled)
- microSD™ card (preinstalled)
- USB cable
- 3.5mm stereo headset
- Power adapter
- Quick start guide
- Safety and regulatory guide
- Call center card (hotline card)
- Warranty card

Your phone

Front panel

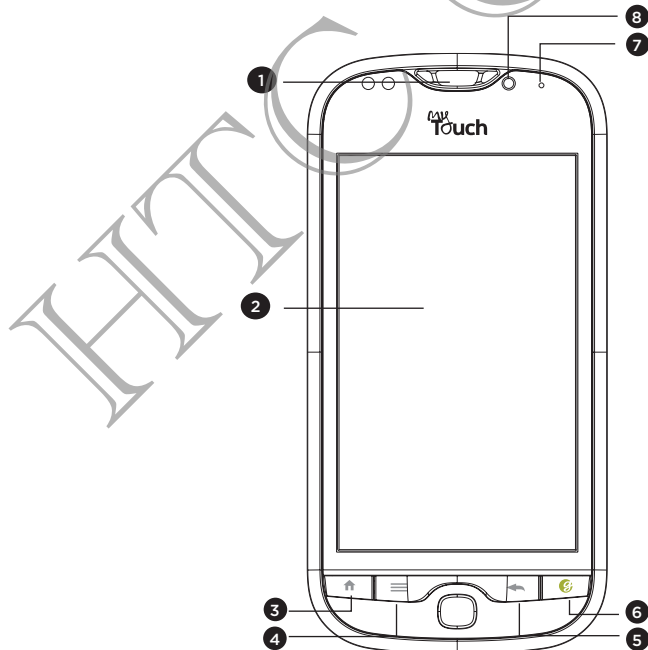

- 1 Earpiece
- 2 Touch screen
- 3 HOME
- 4 MENU
- 5 BACK
- 6 SEARCH
- 7 Notification LED
- 8 Front camera
- 9 Camera

Left panel

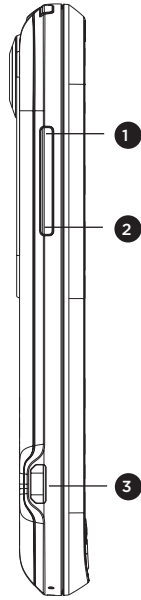

- 1 VOLUME UP
- 2 VOLUME DOWN
- 3 USB connector

Back panel

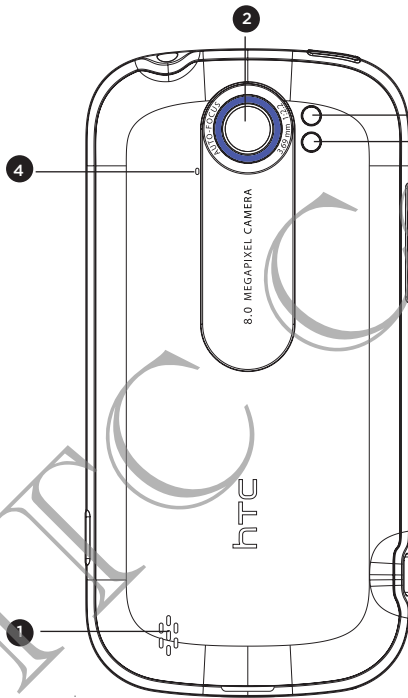

- 1 Speaker
- 2 8 megapixel camera
- 3 LED flash
- 4 Microphone

Top panel

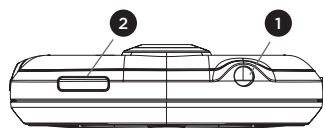

- 1 3.5mm headset jack
- 2 POWER

Back cover

Removing the back cover

Remove the back cover to access the battery, SIM card slot, and storage card slot.

1. With the phone turned off, hold your phone securely with the front facing down.
2. With your thumb, pull the back cover out to remove it.

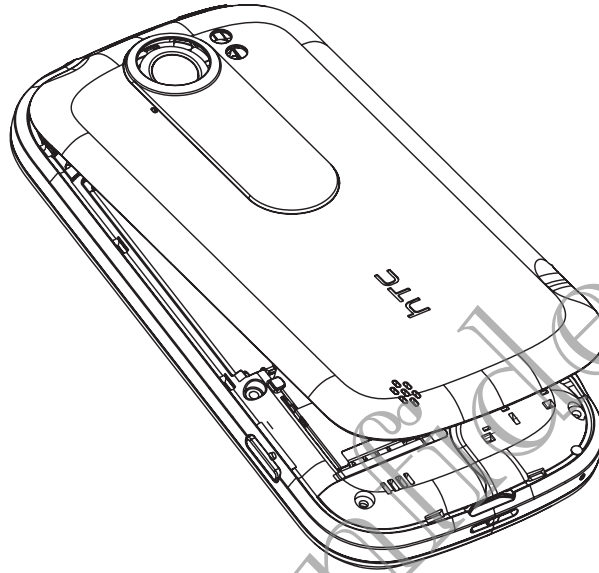

Replacing the back cover

1. Align the two teeth underneath the back cover (one on each side) with the two notches on the bottom of the phone.
2. Place the back cover on the phone, gently press down on the cover with your thumbs, and then push it in until it clicks and locks into place.

 Your phone's antenna is placed underneath the back cover. We recommend that you make sure the back cover is correctly secured to the phone's back panel to get the best radio reception for your phone.

SIM card

The SIM card contains your phone number, service details, and phonebook/message memory. Your phone supports both 1.8V and 3V SIM cards.



Some legacy SIM cards may not function with your phone. You should consult with your mobile operator for a replacement SIM card. There may be fees for this service.

Inserting the SIM card

1. Take the back cover off.
2. Remove the battery.
3. With the SIM card's gold contacts facing down and its cut-off corner facing out, insert the SIM card into the SIM card slot.

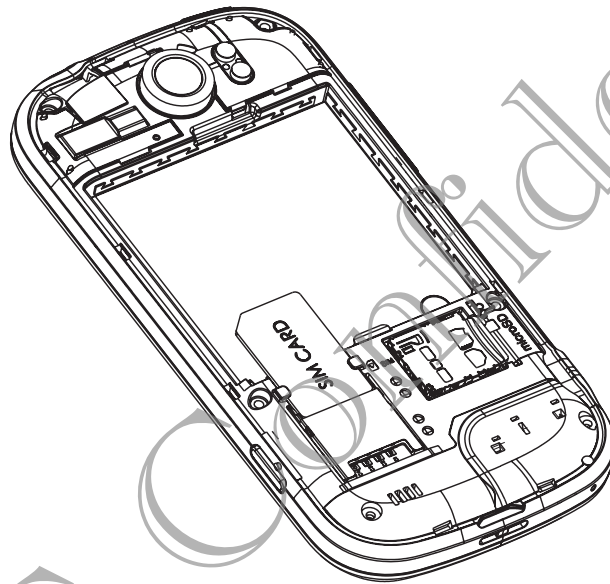

Removing the SIM card

Make sure to switch off your phone before removing your SIM card.

1. Take the back cover off.
2. Remove the battery.
3. With your thumb, slide the SIM card out from the SIM card slot.

Storage card

Use the storage card to store your photos, videos, and music. You'll find the storage card already inserted in your phone.

Inserting the storage card

1. Take the back cover off.
2. Open the battery compartment door.
3. Insert the storage card into the storage card slot with its gold contacts facing down and push it until it clicks into place.

Removing the storage card

 If your phone is on you must first “unmount” the storage card before removing it to prevent corrupting or damaging the files in the storage card.

1. Take the back cover off.
2. Push the storage card in to eject it from its slot.
3. Slide the storage card out from its slot.

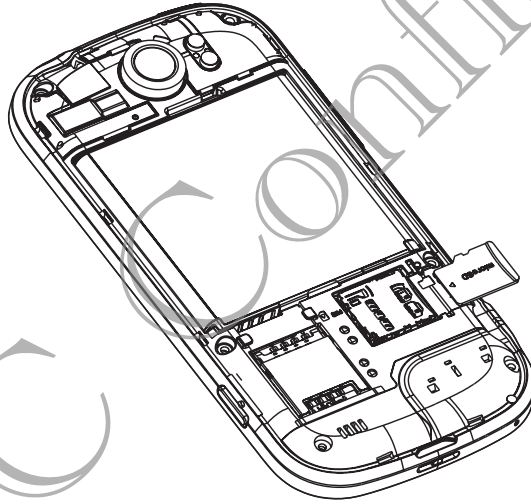

Unmounting the storage card

If you want to format your storage card, you need to unmount it first.

1. From the Home screen, press  , and then tap **Settings**.
2. Scroll down the screen, and then tap **SD & phone storage**.
3. Tap **Unmount SD card**.

Battery

Your phone uses a rechargeable battery. Please use only original batteries and accessories that came with your phone or replacements that we recommend.

How long the battery can last before it needs recharging depends on how you use your phone. Among these are the phone features and accessories you use (for example, leaving your Bluetooth™ connection always on uses more power). Long phone calls and frequent web browsing uses up a lot of battery power. Also, consider your location: poor signal strength from your mobile network and extreme temperature make the battery work harder.

Removing the battery

1. Take the back cover off.
2. Pull the battery out.

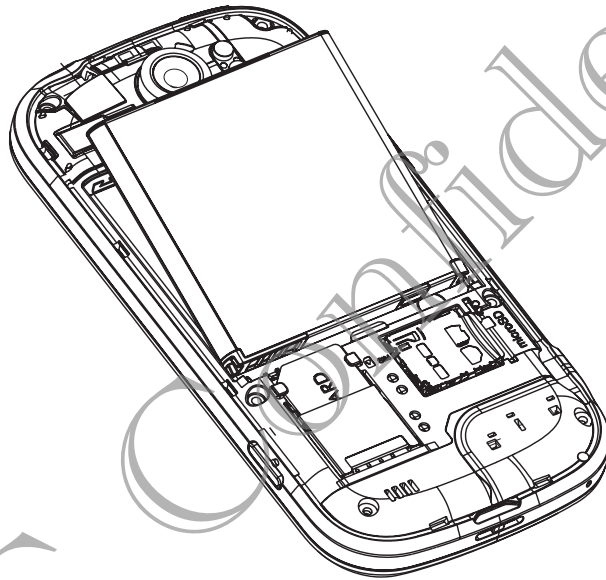

Inserting the battery

1. Take the back cover off.
2. Insert the battery (with its exposed copper contacts first) into the battery compartment.

Charging the battery

The battery is partially charged when shipped. Before you turn on and start using your phone, it is recommended that you charge the battery. Some batteries perform best after several full charge/discharge cycles.

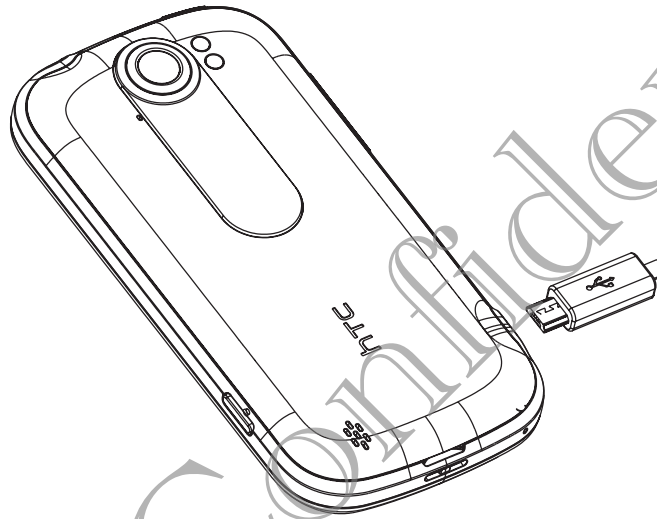

- When the phone is shipped, the battery is already installed on your phone. A thin film is inserted between the battery and the compartment. You need to remove this film before you can charge the battery.
- Only the power adapter and USB sync cable provided with your phone must be used to charge the battery.
- Do not remove the battery from the phone while you are charging it using the power or car adapter.

1. Plug the power adapter into the USB connector of your phone.



2. Plug in the power adapter to an electrical outlet to start charging the battery.

As the battery is being charged, the notification LED shows a solid orange light. The light turns to solid green when the phone is fully charged.

When you charge the battery while the phone is on, the charging battery icon  is displayed in your phone's status bar. After the battery has been fully charged, the charging battery icon turns to a full battery icon .

As a safety precaution, the battery stops charging when it overheats.

Switching your phone on or off

Switching your phone on

Press the POWER button. Easy.



When you turn on the phone for the first time, you'll need to set it up.

Switching your phone off

1. If the display is off, press the POWER button to turn it back on, then unlock the screen by sliding the bar down on the lock screen.
2. Press and hold the POWER button for a few seconds.
3. When the Power options menu appears, tap **Power off**.

Entering your PIN

Most SIM cards come with a PIN (personal identification number) set by your mobile operator. If you're asked for a PIN, enter it and then tap **OK**.



If you enter the wrong PIN three times, your SIM card is blocked. No problem. Just contact your mobile operator and ask for the PUK (PIN Unblocking Key).

Finger gestures

Tap	When you want to type using the keyboard, select items onscreen such as application and settings icons, or press onscreen buttons, simply tap them with your finger.
Press and hold	To open the available options for an item (for example, a contact or link in a web page), simply press and hold the item.
Swipe or slide	To swipe or slide means to quickly drag your finger vertically or horizontally across the screen.
Drag	Press and hold your finger with some pressure before you start to drag. While dragging, do not release your finger until you have reached the target position.
Flick	Flicking the screen is similar to swiping, except that you need to swipe your finger in light, quicker strokes. This finger gesture is always in a vertical direction, such as when flicking the contacts or message list.
Rotate	For most screens, you can automatically change the screen orientation from portrait to landscape by turning the phone sideways. When entering text, you can turn the phone sideways to bring up a bigger keyboard.
Pinch	In some apps, like Gallery or the web browser, you can "pinch" the screen using two fingers (for example, thumb and index finger) to zoom in or zoom out when viewing a picture or a web page.

Setting up your phone for the first time

When you switch on your phone for the first time, you'll be asked to set up your phone. You can choose your language, how you want to connect to the Internet, and whether you want your current location to be automatically detected. If you still have personal contacts and calendar events stored on your old phone, you can easily transfer them to your new phone through Bluetooth as well.

Be sure to sign in to your Google Account so you can use Google apps like Gmail™ and Android Market™. You can also set up your other email accounts, favorite social networks like Facebook and Twitter™, and more.

Just follow the onscreen instructions and you'll be up and running with your phone in no time.



Some features that need to connect to the Internet such as location-based services and auto-sync of your online accounts may incur extra data fees from your mobile operator. Don't worry. You can enable or disable them in your phone's settings as you go along later on.

Ways of getting contacts into your phone

There are several ways you can add contacts to your phone. You can sync your phone with contacts from your Google Account, computer, Facebook, and more.

HTC Sync	Sync the contacts from your old phone to your computer, and then use HTC Sync to sync your new HTC phone with your computer's Microsoft Outlook, Outlook Express or Windows Contacts.
Gmail	Google contacts are imported to your phone after you sign in to your Google Account. You can also create more Google contacts right from your phone.
Facebook	Log in to your Facebook account through Facebook for HTC Sense to import your Facebook friends' contact information.
Phone contacts	You can choose to create and store contacts in your phone memory or transfer existing ones from your old phone.
SIM card	Copy all your SIM contacts to your phone.
Microsoft Exchange ActiveSync	Your phone syncs your work contacts from the Microsoft Exchange ActiveSync Server in your workplace.
Transfer Data	Use the Transfer Data app to transfer not only your contacts, but also calendar events and text messages from your old phone to your new HTC phone.

Home screen

Your Home screen is where you make your phone your own. It comes with a weather clock widget that shows the time and weather in your current location. You can also add your favorite applications, shortcuts, folders and widgets so they're always just a tap away. To find out how, see [Personalizing](#) on page 30.

Extended Home screen

As you start to do more things with your phone, you might find that one Home screen is not enough. No problem. You can use up to six extra screens. It should be plenty.

Slide your finger horizontally to the left or right and you'll discover more space for adding icons, widgets, and more.



Press  to return to the main Home screen (that is, the center home screen).

Using Leap view

To jump straight to the screen that you want, press  or pinch the screen to show the Leap view. It reveals all seven Home screens as thumbnails.





Just tap the one you want and you'll leap right there.

Basics

Adjusting the volume

Adjusting the ringer volume changes the volume level of the phone ringtone, while adjusting the media volume changes the volume level of sound notifications and music or video playback.

Adjusting the ringer volume

- Press the VOLUME UP or VOLUME DOWN button on the left panel of the phone to adjust the ringer volume to your desired level. The Ringer volume window appears on the screen to display the volume levels.
- While in the lowest ringer volume level (Silent mode), press VOLUME DOWN once to set your phone to Vibrate mode. The phone vibrates and the vibrate mode icon  appears in the status bar.
- While in Vibrate mode, press VOLUME UP once to switch to silent mode. The speaker mute icon  displays in the status bar.

Adjusting the media volume

When playing music or watching video, press the VOLUME UP or VOLUME DOWN button on the left panel of the phone to adjust the volume. The Media volume window appears on the screen to display the volume level.

Adjusting the earpiece volume for phone calls

During a phone call, press the VOLUME UP or VOLUME DOWN button.

Adjusting the volume via settings

1. From the Home screen, press , and then tap **Settings > Sound > Volume**.
2. Drag the volume sliders to the left or right to adjust the volume levels of your phone's ringtone, media playback, alarms, and notifications. Your phone briefly plays a sample tone with the volume being adjusted as you drag a slider.
3. If you want the same volume for your ringtone and notifications, select **Use incoming call volume for notifications**.
4. When you're done, tap **OK**.

Sleep mode

Sleep mode saves battery power by putting your phone into a low power state while the display is off. It also stops accidental button presses when the phone's in your bag or pocket. You'll still receive messages and calls though.

Switching to Sleep mode

Briefly press the POWER button to turn off the display and switch your phone to Sleep mode. Your phone also automatically goes into Sleep mode when it's idle for a while.

Waking up from Sleep mode

To wake your phone up manually, press the POWER button. You'll need to unlock the screen.



Your phone automatically wakes up when you have an incoming call.

Unlocking the screen

Press the bar on the lock screen and then slide your finger down to unlock the screen or answer an incoming call.



If you have set up a screen unlock pattern, pin, or password, you will be asked to draw the pattern on the screen or enter the PIN or password before it unlocks.

Status and notifications

Status icons

You can tell a lot about your phone by checking the icons in its status bar.



Here's what each icon means:

 Signal strength	 Battery is full
 GPRS connected	 Battery is charging
 GPRS in use	 Battery is low (20% remaining)
 EDGE connected	 Battery is very low (10% remaining)
 EDGE in use	 Silent mode
 3G connected	 Vibrate mode
 3G in use	 Phone microphone is mute
 HSDPA connected	 Speakerphone is on
 HSDPA in use	 Wired microphone headset connected
 Roaming	 Wired headset connected
 No signal	 Bluetooth is on
 No SIM card installed	 Connected to a Bluetooth device
 Connected to a Wi-Fi network	 Airplane mode
 Data synchronizing	 GPS is on
 Network sharing is on	 Alarm is set

Notification icons

A busy life means a busy phone. Notification icons on the status bar make it easy for you to keep on top of your messages, calendar events, and alarms.

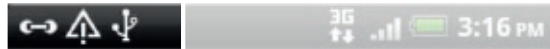

Here's what each one means:

 New Gmail message	 General notification
 New Microsoft Exchange ActiveSync or POP3/IMAP email	 Call in progress
 Problem with email delivery	 Missed call
 New SMS/MMS	 Call on hold
 Problem with SMS/MMS delivery	 Call forwarding on
 New Google Talk instant message	 Message forwarding on
 New voicemail	 The phone is connected to a computer via USB cable
 Upcoming event	 Wi-Fi is on and wireless networks are available
 New updates from your social networks	 Portable Wi-Fi Hotspot is on
 Matched contacts suggestion	 Uploading data (animated)
 Bluetooth pairing request	 Downloading data (animated)
 Phone software update available	 Waiting to upload
 Song is playing	 Downloaded Android Market app installed successfully
 FM Radio app in use	 Update available for an app downloaded from Android Market
 Voice recording is on	 Storage card is safe to remove or storage card is being prepared
 Compass needs orientation	 No storage card installed on the phone
 More (not displayed) notifications	 Storage card is low on free space

Notification LED

The notification LED shows a:

- Solid green light when the phone is connected to the power adapter or a computer and the battery is fully charged.
- Flashing green light when you have a pending notification.
- Solid orange light when the battery is being charged.
- Flashing red light when the battery level reaches very low.

Notifications panel

When you get a new notification, you can open the Notifications panel to see the message, reminder or event notification. The Notifications panel lets you quickly switch between recently-opened apps, and also lets you easily turn on settings such as Wi-Fi and Bluetooth.

To open the Notifications panel, press and hold the status bar, then slide your finger downward.

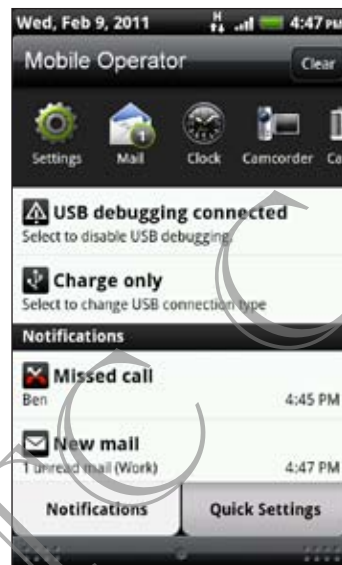

If you have several notifications, you can scroll down the screen to see them all.



You can also open the Notifications panel on the Home screen by pressing  and then tapping Notifications.

Switching between recently opened apps

On the Notifications panel, you can easily access up to eight apps you just recently opened.

1. Press and hold the status bar, then slide your finger downward to open the Notifications panel.
2. In the Recent apps section, slide your finger left or right to see recently-opened apps.



3. Tap an app to open it.



Press and hold  to view recently used apps.

Using Quick Settings

The Quick Settings tab lets you easily turn on Wi-Fi, Bluetooth, GPS, and more, and also provides a quick shortcut to all phone settings.

1. Press and hold the status bar, then slide your finger downward to open the Notifications panel.
2. Tap the Quick Settings tab.
3. Tap the check box next to an item to turn it off or on.



Closing the Notifications panel

Press and hold the bottom bar of the Notifications panel, then slide your finger up the screen. Or just press .

Connecting your phone to a computer

Whenever you connect your phone to a computer using the USB cable, the Connect to PC screen opens and lets you choose the type of USB connection.

Select one of the following choices, and then tap **Done**:

Charge only	Select this option if you only want to charge the battery while your phone is connected to your computer.
HTC Sync	Select this option to synchronize contacts, calendar, and other information between your computer and your phone.
Disk drive	This mode is available only when there's a storage card on your phone. Select this mode when you want to copy files between your phone's storage card and your computer. When Disk drive mode is enabled while your phone is connected to the computer, you will not be able to use apps on your phone to access the storage card.
USB tethering	When you do not have Internet connection on your computer, you can select this mode to share your phone's mobile data connection with your computer.
Internet pass-through	If you don't have a data plan for your phone or you don't have access to a Wi-Fi network, you can select this mode to share your computer's Internet connection with your phone.

Copying files to or from the storage card

You can copy your music, photos, and other files to your phone's storage card.

1. Connect your phone to your computer using the supplied USB cable.
2. On your phone's Connect to PC screen, tap **Disk drive**, and then tap **Done**. On your computer, the connected phone is recognized as a removable disk.
3. Navigate to the removable disk and open it.
4. Do one of the following:
 - Copy the files from the computer to the phone's storage card's root folder.
 - Copy the files from the phone's storage card to a folder in your computer.
5. After copying the files, unmount the removable disk (that is, the connected phone) as required by your computer's operating system to safely remove your phone.
6. Do one of the following:
 - Disconnect the phone from the computer.
 - If you want to keep the phone connected to the computer but want the phone to be able to access the storage card, open the Notifications panel, tap **Disk drive**, select an option except **Disk drive**, and then tap **Done**.

Copying text, looking up information, and sharing

In applications such as the web browser and Mail, you can select text and choose what you want to do with it.

After selecting text, you can:

- Copy it.
- Search for it using Google Search.
- Look it up on Wikipedia®, YouTube™, or Google Dictionary™.
- Get a translation of the text from Google Translate™.
- Share the text in a new email, text, or multimedia message or in your status update on a social network.

Selecting text

1. Press and hold on a word.
2. Drag the start and end markers to highlight the surrounding text you want to select.



To select text in a link, press and hold the link, and then tap **Copy link URL**.

Copying and pasting text





1. After you have selected the text you want to copy, tap .

The selected text is then copied to the clipboard.

2. In a text entry field (for example while composing a message), press and hold at the point where you want to paste the text.
3. Tap **Paste**.

Searching or translating text

1. After you have selected the text you want to search for or translate, tap .
2. Tap one of the following tabs:

	Google Search Look for related information using Google Search, based on the text that you selected.
	Wikipedia Look for related information on Wikipedia, based on the text that you selected.
	YouTube Look for videos on YouTube, based on the text that you selected.
	Google Translate Translate the text to another language.
	Google Dictionary Look up the selected text in the dictionary.

Pasting text in a new message or social network status update

1. After you have selected the text you want to share, tap .
2. Choose whether to paste the selected text in a new text, multimedia, or email message or in your status update on a social network such as Twitter.

Personalizing

Making your phone truly yours

Make your phone look and sound just the way you want it. Personalize your phone with a different wallpaper, skin, ringtone, and notification sound for events such as incoming text, email, and calendar reminders.

Tap the Personalize button  right on the Home screen to get started.

Personalizing your phone with scenes

Your phone becomes multiple phones in one when you use scenes. Scenes are personalized Home screen layouts that you can quickly apply to your phone. By switching between scenes, you instantly turn your phone into your perfect weekend phone, travel phone, work phone, or pure play phone.



Everytime you add or modify something on the Home screen, your phone automatically saves your changes to the current scene selected.

Using a preset scene

Your phone features preset scenes, each preconfigured with a different wallpaper and collection of widgets that reflect different moments in your life. You can choose a scene that is suitable for work, play, travel, or your social life.



1. From the Home screen, tap  > Scene.
2. Slide your finger on the screen from right to left to select the scene you want.
3. Tap Apply.



To download more scenes, tap  > Scene > Get more.

Creating a new scene



You'll start with an empty Home screen when you create a new scene.

1. From the Home screen, tap  > Scene.
2. Press , and then tap New.
3. Enter a new scene name, then tap Done.
4. Personalize the scene by adding widgets and other elements, arranging the Home screen layout, and changing the skin or wallpaper. All of your changes will be automatically saved to this scene.

Renaming a scene

1. From the Home screen, tap  > **Scene**.
2. Slide your finger on the screen from right to left to select the scene you want to rename.
3. Press and hold a scene thumbnail, then tap **Rename**.
4. Enter a new scene name, then tap **Done**.

Deleting scenes

1. From the Home screen, tap  > **Scene**.
2. Press , and then tap **Delete**.
3. Slide your finger on the screen from right to left to browse through scenes, then tap one or more scenes you want to delete.
4. Tap **Delete**.

Changing your wallpaper

Personalizing your wallpaper with your favorite photo is a quick and easy way to change the feel of your phone and give it a fresh look. Browse the collection of wallpapers included in your phone or choose from photos that you have taken with the camera. You can also change your Home screen to use an animated wallpaper.

1. From the Home screen, tap  > **Wallpaper**.
2. Tap one of the following:

HTC wallpapers	Choose a preset wallpaper, then tap Preview > Apply .
Live wallpapers	Choose from preset animated wallpapers. Tap Preview to view the animation, and then tap Apply .
Gallery	Choose a photo that you have taken using the camera or copied to your storage card. Crop the photo and then tap Save .



To download more wallpapers, tap  > **Wallpaper** > **HTC wallpapers** > **Get more**.

Applying a new skin

Personalize beyond the Home screen by applying a new skin. Skins are set to give a different look and feel to most of your phone's onscreen buttons, application screens, option menus, and other items.

1. From the Home screen, tap  > Skin.
2. Slide your finger on the screen from right to left to select the skin you want.
3. Tap Apply.



To download more skins, tap  > Skin > Get more.

Personalizing your Home screen with widgets

Widgets put at-a-glance important information and media content up front on your Home screen. Some widgets are already added to your Home screen for your convenience. You can add more from the available selections of widgets, or download more widgets.

Adding a widget to your Home screen

1. Go to a part of the Home screen where there's space to add a new widget.
2. Tap  > Widget.
3. Select a widget that you want.
4. Most HTC widgets are available in a variety of designs and sizes to suit your needs. Slide your finger on the screen from right to left to view the different styles, and then tap Select to choose one.

You can also add widgets that allow you to quickly switch on or off certain settings of your phone, such as Wi-Fi, Mobile Network, and Bluetooth. Scroll down the widgets list, tap Settings, and then tap the widget that you want.

Changing the settings of a widget

You can modify basic settings of some widgets (for example, the People and Mail widgets) from the Home screen.

1. Press and hold a widget on the Home screen. The phone vibrates and you'll see a colored box around the widget. Don't lift your finger just yet.
2. Drag the widget to the **Edit** button (if it's enabled).



The relevant screen where you can change some settings for this widget then opens.

3. Customize the widget settings.

Adding icons and other shortcuts on your Home screen



Place app icons on your Home screen to open apps quicker. You can also add shortcuts to settings and specific information such as a bookmarked webpage, someone's phone number, a music playlist, route directions, and many other items, to your Home screen.



The shortcuts available depend on the apps that are installed on your phone.

1. Go to a part of the Home screen where there's space to add a new icon or shortcut.
2. Tap  and then tap **App** to add an app icon, or **Shortcut** to add a shortcut to a setting or information.



To add an app icon on the Home screen, you can also press , tap , and then press and hold an app icon. Without lifting your finger, drag the icon to an empty area on the Home screen, and then release it.

Adding folders on your Home screen

Use folders to group related apps and other shortcuts to keep your Home screen tidy and organized. You can also add information folders that show up-to-date information such as Bluetooth received files, your Facebook phonebook, and more.

Creating a new folder and adding items to it

1. Go to a part of the Home screen where there's space to add a new folder.
2. Tap  > **Folder**.
3. Tap **New Folder**.
4. Press and hold an app icon or a shortcut that you want to move to the folder. The phone then vibrates. Don't lift your finger just yet.
5. Drag the app icon or shortcut and drop it on top of the folder.

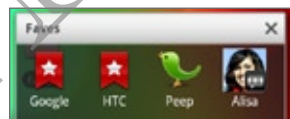

Simply tap the folder to open it so you can access the apps and shortcuts inside the folder.

Renaming a folder

1. Tap the folder to open it.
2. Press and hold the folder window's title bar.
3. Enter a new folder name and then tap **OK**.

Rearranging or removing widgets and icons on your Home screen

Rearrange the widgets and icons on your Home screen to make room for adding more items. You can also remove widgets and icons that you don't frequently use.

Moving a widget or icon

1. Press and hold the widget or icon you want to move. The phone vibrates and you'll see a colored box around the widget or icon. Don't lift your finger just yet.
2. Drag the widget or icon to a new location on the screen. You can pause at the left or right edge of the screen to drag the widget or icon onto another Home screen panel.
3. When the widget or icon is where you want it, lift your finger.

Removing a widget or icon

1. Press and hold the widget or icon you want to remove. The phone vibrates and you'll see a colored box around the widget or icon. Don't lift your finger just yet.
2. Drag the widget or icon to the Remove button.
3. When the widget or icon also turns red, lift your finger.

Rearranging the Home screen

Reorder your Home screen panels in any way that fits how you use them. For example, move the panels with frequently-used widgets, shortcuts, and folders closer to the main Home screen.



The center thumbnail in Leap view is always the main Home screen.



1. Pinch the Home screen to show the Leap view.
2. Press and hold the thumbnail of the home screen you want to move. The phone then vibrates. Don't lift your finger just yet.
3. Drag the thumbnail to its new position, and then lift your finger.



Using sound sets

Sound sets are different collections of ringtone, notification, and alarm sounds you can use to personalize the way your phone alerts you. Using sound sets, you can instantly change from subtle ringtone and notification sounds while you're in the office into something fun when you're out with friends.

Choosing a preset sound set

1. From the Home screen, tap  > Sound set.
2. On the Sound sets screen, tap a sound set name.
3. You can tap  to hear samples of the ringtone, notification sounds, and alarm for that sound set.
4. Tap Apply.



To download more sound sets, tap  > Sound set > Get more.

Creating a sound set

1. From the Home screen, tap  > Sound set.
2. On the Sound sets screen, tap New sound set.
3. Enter a new sound set name, and then tap Done.

The newly created sound set is then added to your phone's list of sound sets. You can assign different tones to the sound set to your preference.



Customizing a sound set

You can customize a sound set by applying your personal choice of ringtone, notification sounds, and alarms that may be from your phone's preset selection or your storage card (except for notification sounds).



Be sure to choose the sound set you want before changing the ringtone, notification sounds, and alarm since your phone automatically saves your changes to the current sound set selected.

Deleting sound sets

1. From the Home screen, tap  > Sound set.
2. Press , and then tap Delete.
3. Tap one or more sound sets you want to delete.
4. Tap Delete.

Changing your ringtones and alarms

Change your ringtones, notification sounds, and alarms to suit your mood or lifestyle. Your changes are saved in the sound set that is currently loaded, overwriting its settings.

Changing the ringtone

1. From the Home screen, tap  > Ringtone.
2. Scroll through the available ringtones and tap the ringtone you want to use. The ringtone briefly plays when selected.
3. If the audio file is on your storage card, tap **New ringtone**, select the item you want to import to the Ringtones list, then tap **OK**.
4. Tap **Apply**.

Changing notification sounds

1. From the Home screen, tap  > Notification sound.
2. Choose the type of notification that you want to change.
3. Scroll through the available tones and tap the item you want to use. A sample tone briefly plays when selected.
4. Tap **Apply**.



Although you can't import notification sounds from your storage card, you can tap **Get more** to download more audio files from HTC Hub.

Changing the alarm sound

1. From the Home screen, tap  > Alarm.
2. Scroll through the available tones and tap the item you want to use. A sample tone briefly plays when selected.
3. If the audio file is on your storage card, tap **New alarm**, select the item you want to import to the Alarms list, then tap **OK**.
4. Tap **Apply**.

Rearranging or hiding application tabs

You can rearrange the tabs at the bottom of some of your phone's apps to prioritize the types of information you frequently use or remove the tabs you don't really need.

1. Open an app that has the usual tabs at the bottom of its screen (for example, the contact details screen in People).



2. Press and hold a tab. When the screen changes and shows you an empty area, lift your finger.
3. Do any of the following:

Move a tab	Press and hold the tab you want to move, and then drag it to its new position.
Remove a tab	Press and hold a tab you want to hide, then drag it up. When you see a colored box, lift your finger.

4. When you're done, press .

Adding a tab back

1. Open the app from which you previously removed some tabs.
2. Press and hold a tab. When the screen changes and shows you some of your hidden tabs, lift your finger.
3. Press and hold the tab you want to show, then drag it down to where you want to position it again.

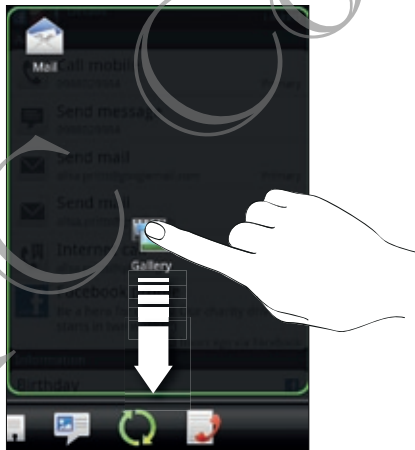

4. When you're done, press .

Phone calls

Different ways of making calls

Besides making calls from the phone dialer screen on your phone, you can tap a number in a text message or email to call, or press a single number on the phone dialer to quickly call a contact.





Most SIM cards come with a PIN (personal identification number) set by your mobile operator. If you're asked for a PIN, enter it and then tap **OK**. If you enter the wrong PIN three times, your SIM card is blocked. Don't worry. Just contact your mobile operator and ask for the PUK (PIN Unblocking Key).



Making a call on the Phone dialer screen

You can either dial a number directly, or use the Smart dial feature to search and call a stored contact or a number from your call history.

1. On the Home screen, tap **Phone**.
2. Begin entering the first few digits of a phone number or characters of a contact name on the phone keypad. The Phone dialer screen then displays a list of matching numbers and names.



If you enter a wrong digit or letter, tap  to delete it. To erase the entire entry, press and hold .

3. Tap  to close the phone keypad and to see if there are more matching numbers or contacts.
4. To browse through the filtered list, flick through the list or slide your finger up or down the list slowly.
5. To place a call, do one of the following:
 - Tap a phone number or contact from the list.
 - After entering a complete number, tap **Call**.
 - To call a different phone number associated with the contact, you can tap  at the right side of the contact name. On the contact details screen, tap the number you want to call.

While dialing or when the call is in progress, the status bar displays the call in progress icon .

What is Smart dial?

The phone dialer's Smart dial feature makes it quick and easy for you to place a call.

Simply enter the phone number or first few letters of the person's name you want to call. Smart dial automatically searches and filters your contacts list (stored on your phone, SIM card, and online accounts such as Google Account and Exchange ActiveSync) and the phone numbers from the call history.

Using Speed dial

Use Speed dial to call a phone number with a single tap. For example, if you assign a contact's number to the number 2 key, you can just press and hold 2 to dial the number.



The number 1 key is generally reserved for your voicemail. Press and hold this key to call voicemail and retrieve your voicemail messages.

Assigning a speed dial key

1. On the Home screen, tap **Phone**.
2. Press **≡**, and then tap **Speed dial > Add new**.
3. Enter the name of the contact you want to add. When the name comes up in the list, tap the name.
4. On the Speed dial screen, choose the phone number of the contact to use, and a speed dial key to assign.
5. Tap **Save**.

Calling a phone number in a text message

1. Tap the phone number within the message.

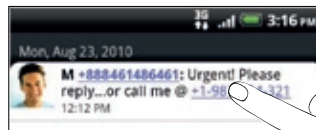

2. Edit the phone number if needed, and then tap **Call**.



To call the message sender, press and hold the sender or the received message, and then tap **Call** on the options menu.

Calling a phone number in an email

Want to call a number that's in an email? No problem. Numbers of at least 5 digits along with any of the following are recognized as phone numbers:

- Numbers starting with a plus sign (+). For example, +1-987-654-32 1 or +198765432 1.
- Numbers starting with an area or country code enclosed in a parenthesis. For example, (02)98765432 1 or (02)987-654-32 1.
- Numbers separated by dashes. For example, (02)-987-654-32 1 or 0987-654-32 1.

1. In the email body, tap the phone number.
2. Edit the phone number if needed, and then tap **Call**.

Making an emergency call

In some regions, you can make emergency calls from your phone even if you don't have a SIM card installed or your SIM card has been blocked.

1. On the Home screen, tap **Phone**.
2. Dial the international emergency number for your locale (for example, 000), and then tap **Call**.



Additional emergency numbers may be included in your SIM card. Contact your mobile operator for details.

If you've enabled but forgotten your lock screen password, lock pattern, and/or the SIM lock, you can still make emergency calls by tapping **Emergency call** on the screen.

Receiving calls

When you receive a phone call from a contact, the Incoming call screen appears.



You can use your phone's polite ringer and pocket mode features for receiving calls. To find out how, see [Changing sound settings](#) on page 184.

Answering a call

To answer a call:

- Tap **Answer**.
- If the display is off when you get a call, the Lock screen appears. Drag the bar that shows the caller name or number downward.

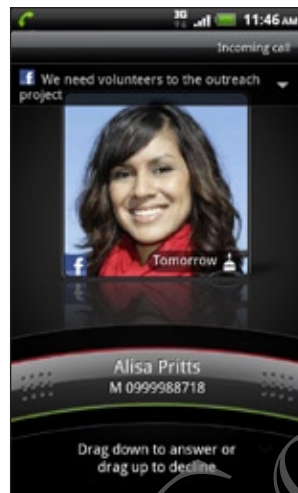

Rejecting a call

Do one of the following:

- Tap **Decline**.
- If the display is off when you get a call, drag the bar upward on the Lock screen, or press and then tap **Decline**.
- To reject the call and send a text message, press , and then tap **Send message**.



You can also Press the POWER button twice to reject a call.

Changing the text message to send out for rejected calls

1. On the Phone dialer screen, press .
2. Tap **Settings > Edit default message**.
3. Enter the new message, and then tap **OK**.

Muting the ringing sound without rejecting the call

Do one of the following:

- Press the VOLUME DOWN or VOLUME UP button.
- Press the POWER button.
- Place the phone face down on a level surface.



If the phone is already facing down, the phone will still ring when there are subsequent incoming calls.

HTC Caller ID

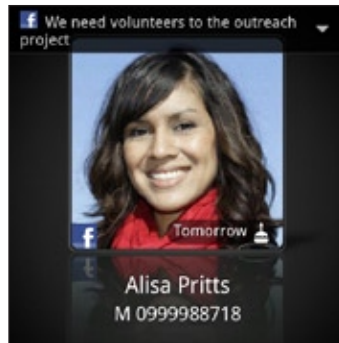

Everytime you make a call or your friend gives you a ring, you get to see your friend's latest status update from social networks like Facebook or Twitter right on the call screen. You also won't miss people's birthdays. You'll see a birthday reminder, if your friend's birthday will occur sometime within the next seven days.



What can I do during a call?

When a call is in progress, use the buttons onscreen to mute or unmute the microphone or to turn the speakerphone on or off. You can also press  and choose whether to add a call, place the call on hold, mute the microphone, and more.

Putting a call on hold

1. Press  and then tap Hold to put the call on hold. When you put a call on hold, the status bar displays the hold call icon .
2. Press , and then tap Unhold to resume the call.

Switching between calls

If you're already on a call and accept another call, you can choose to switch between the two calls.

1. When you receive another call, tap **Answer** to accept the second call and put the first call on hold.
2. To switch between the calls, tap the person you want to talk to on the screen.



3. To end the current call and return to the other call, tap **End call**.

Turning the speakerphone on during a call



To decrease potential damage to your hearing, do not hold your phone against your ear when the speakerphone is on.



Do one of the following:

- Flip your phone over during a call (be sure that **Flip for speaker** is selected in  >  > **Settings** > **Sound**).
- On the call screen, tap .

The speakerphone icon  appears in the status bar when the speakerphone is on.

To turn the speakerphone off, just flip the phone over again, facing it up. Or tap  again.

Muting the microphone during a call

On the call screen, tap  to toggle between turning the microphone on or off. When the microphone is turned off, the mute icon  appears in the status bar.

Ending a call

Do one of the following to end the call:

- On the call screen, tap **End call**.

If the phone display is off, press **POWER** to turn on the screen so you can tap **End call**.





- Slide open the Notifications panel, then tap .
- If you are using the provided wired headset, press the button to end the call.

If the phone number of the person who called is not in your contacts list, you can choose to save the number to your contacts list after you hang up.

Setting up a conference call

Conference calling with your friends, family, or co-workers is easy. Make the first call (or accept a call), and then simply dial each subsequent call to add it to the conference.

 Make sure your SIM card is enabled with conference calling service. Contact your mobile operator for details.



1. Make a call to the first conference call participant.
2. When connected, press , tap **Add call**, and then dial the number of the second participant. The first participant is put on hold when you dial the second participant.
3. When connected to the second participant, tap merge .
4. To add another participant to the conference call, tap  on the conference call screen, and then dial the number of the contact you want to invite to the conference call.
5. When connected, tap  to add the participant to the conference call.
6. To talk to a person in the conference call in private, tap , and then select **Private call** on the options menu.
7. When finished, tap **End call**.

Internet calls

When you're connected to a Wi-Fi network, you can make and receive calls through an Internet calling account.

Adding an Internet calling account

Before you add an Internet calling account, make sure that you've registered with an Internet calling service that supports voice calls over Session Initiation Protocol (SIP).

1. From the Home screen, press , and then tap **Settings > Call**.
2. Under Internet call settings, tap **Accounts**.
3. Tap **Add account**.
4. Enter your account details.
5. Press  to save your account.
6. To set your phone to receive Internet calls on your added account, tap the **Receive incoming calls** check box.

Making an Internet call

Make an Internet call to either your contact's Internet calling account or phone number.

 Internet calls to phone numbers may incur additional fees or may not be supported by your mobile operator.

Call any of the following:

Internet calling account	<ul style="list-style-type: none"> ▪ In People, tap a contact who has an Internet calling account, and then tap Internet call. ▪ In Call History, tap an Internet call log.
Phone number	See Different ways of making calls on page 39. But first, set your phone to use Internet calling for your outgoing calls. From the Home screen, press  , and then tap Settings > Call . Tap Use Internet calling , and then select either For all calls or Ask for each call .

Using Call history

Use Call History to check missed calls, your dialed numbers, and received calls.

Checking a missed call

You will see the missed call icon  in the status bar when you miss a call.

1. Slide open the Notifications panel to check who the caller is.
2. To return the call, tap the missed call notification. Then tap the caller's name or number on the Call History screen.



Checking calls in the Call History

From the Home screen, tap  > Call History.



You can also tap  on the phone dialer screen.

On the Call History screen, you can:

- Tap a name or number in the list to call.
- Press and hold a name or number in the list to display the options menu.
- Tap  to check only the call history of a particular contact.
- Press , then tap **View** to display just a particular type of calls such as missed calls or outgoing calls.

Adding a new phone number to your contacts from Call History

1. On the Call History screen, press and hold the phone number that you want to save, and then tap **Save to People**.
2. Choose whether to create a new contact or save the number to an existing contact on your phone.

3. Do any of the following:

- When creating a new contact, enter the contact name, contact type, and other information in the blank contact record that appears. The phone number is automatically added to the mobile field in the phone section. To store it as another type of number, for example a home number, tap the **Mobile** button.
- When saving the number to an existing contact, tap a contact stored on your phone, and then select the number type.

4. Tap **Save**.

Clearing the Call History list

On the Call History screen, do one of the following:

Remove one name or number	Press and hold the name or number, and then tap Delete from call history .
Clear the entire list	Press  , and then tap Delete all .

Using Home dialing

When you're on a trip abroad, it's easy to dial friends and family from home.

Your home country code is automatically added when you make calls while roaming.

1. On the Home screen, tap **Phone**.
2. Enter the phone number from your home country that you wish to call.



If you enter a leading zero, it will be removed. If you enter a plus (+) sign before the phone number, your phone will dial normally.

The Home Dialing screen opens and shows the country code to be added before the phone number.

3. If you want to change the country code, choose the country that you want from the country selection box.
4. Tap **Done**, and then place the call.

Turning off Home dialing

If you prefer to manually enter complete phone numbers to call while roaming, you can turn off Home dialing.

1. From the Home screen, press , and then tap **Settings > Call**.
2. Select the **Home country** check box.

Call services

Your phone can directly link to the mobile phone network, and enable you to access and change the settings of various phone services for your phone. Call services may include call forwarding, call waiting, voicemail, and more. Contact your mobile operator to find out about the availability of call services for your phone.

To open call services, press  from the Home screen, and then tap **Settings > Call**.

Fixed Dialing Numbers	Restrict outgoing calls to a fixed set of numbers. To enable this feature, you must know your SIM card's PIN2 code.
Voicemail service	Shows the current voicemail service being used.
Voicemail settings	Specify another voicemail number aside from the voice mail number on your SIM card.
Clear voicemail notification	If you have a notification of a new voicemail, you can clear the notification with this option.
Phone settings	Edit the call reject message, choose whether to open the message editor when you reject a call with a message, and choose whether to allow automatic saving of an unknown contact number when a call with that number ends.
Call forwarding	Select how you want your phone to handle busy, unanswered, and unreachable calls. You can also set the call forwarding option for all incoming calls.
Call barring settings	Choose whether to block various categories of incoming and outgoing call.
Additional call settings	Enable or disable operator services such as caller ID and call waiting.
Home country	Enable or disable the Home dialing feature.
Home dialing	Set the country code to be automatically added before the phone numbers you dial while you're roaming.
Accounts	Add, modify, or remove Internet calling accounts. You can also choose whether to receive incoming Internet calls.
Use Internet calling	Select whether to use Internet calling for all calls you make or for Internet address calls only, or to be asked which you prefer for each call you make.

Turning Airplane mode on or off

In many countries, you are required by law to turn off the phone while on board an aircraft. A way to turn off the phone function is to switch your phone to Airplane mode.

When you enable Airplane mode, all wireless radios on your phone are turned off, including the call function, data services, Bluetooth, and Wi-Fi. When you disable Airplane mode, the call function is turned back on and the previous state of Bluetooth and Wi-Fi is restored.

To turn Airplane mode on or off, press and hold POWER, and then tap **Airplane mode**. When enabled, the Airplane mode icon  is displayed in the status bar.

HTC Confidential

Messages

Opening Messages

Keep in touch with important people in your life. Use the Messages app to compose and send text (SMS) and multimedia messages (MMS).

From the Home screen, tap  > **Messages**. The All messages screen opens, where all your sent and received messages are neatly grouped into conversations, by contact name or phone number.

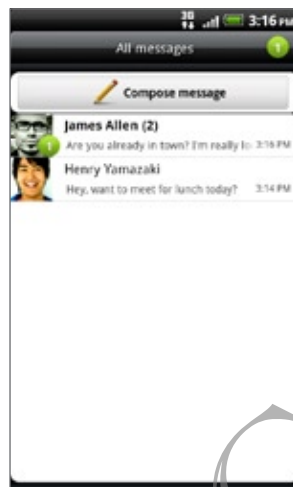



- Scroll up or down the list of conversations by swiping your finger on the screen.
- Tap a contact name or number to view the exchange of messages.



You can also view your messages on the Home screen with the Messages widget.

Sending a text message (SMS)

1. From the Home screen, tap  > **Messages**.
2. Tap **Compose message**.
3. Fill in one or more recipients. You can:
 - Enter the first few letters of a contact name or starting digits of a mobile number. As you type, matching names with phone numbers from your stored contacts are displayed. Tap a name or one of the contact's numbers.
 - Tap , and then select the phone numbers of the contacts to whom you want to send the message. You can also select contact groups as recipients. When you have selected all the message recipients, tap **OK**.
 - Enter the complete phone numbers directly in the **To** field.

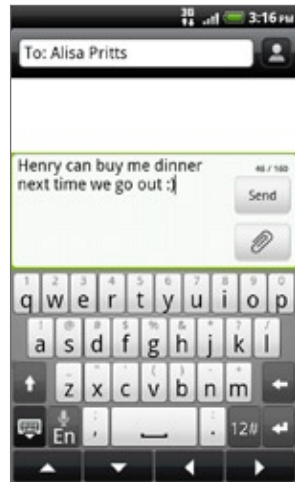

4. Tap the box that says **Add text**, and then enter your message.



- There is a limit on the number of characters for a single text message (displayed above the **Send** button). If you exceed the limit, your text message will be delivered as one but will be billed as more than one message.
- Your text message automatically becomes a multimedia message if you enter an email address as the recipient, add a message subject, attach an item, or compose a very long message.



5. Tap **Send**, or press  to save the message as a draft.

Sending a multimedia message (MMS)

1. From the Home screen, tap  > **Messages**.
2. Tap **Compose message**.
3. Fill in one or more recipients. You can:
 - Enter the first few letters of a contact name or starting digits of a mobile number. As you type, matching names with phone numbers and email addresses from your stored contacts are displayed. Tap a contact's number or email address. Email addresses will be displayed when **Show email address** is selected in Recipient list settings.
 - Tap , and then select the phone numbers of the contacts to whom you want to send the message. You can also select contact groups as recipients. When you have selected all the message recipients, tap **OK**.
 - Enter the complete phone numbers or email address directly in the **To** field.
4. To add a subject line, press  and then tap **Add subject**.
5. Tap the box that says **Add text**, and then enter your message.





6. Tap  and then choose the type of attachment.

Picture	Select Camera to take a photo and attach it, or Gallery to attach a photo from your storage card.
Video	Select Camcorder to capture a video and attach it, or Videos to attach a video from your storage card.
Audio	Select Voice Recorder to make a voice recording and attach it, or Music & sounds to attach a music file or voice recording from your storage card.
App recommendation	Choose an app you've installed from Android Market that you want to share with others. The URL from which the app can be downloaded will be inserted to your message.
Location	Add your current location (requires GPS to be turned on), or a location you pick on a map to your message.
Contact (vCard)	Select a contact, and then select the information to attach.
Appointment (vCalendar)	Select the calendar event you want to attach.

7. To see options for replacing or reviewing your attachment, tap . You can also press , then tap **Remove** to start over.
8. Tap **Send**, or press  to save the message as a draft.

Creating a slideshow

1. After you've added either a photo, video, or audio in the multimedia message you're composing, tap  > **Slideshow**.
2. Do any of the following:

Add a slide	Tap  , and then choose to add a photo or a video.
Add music or a voice recording to a slide	Right after adding a slide, tap  > Audio .
Add a caption to a slide	Tap the box that says Add text .
Edit a slide	Tap  , and then choose to replace, remove, or set the duration of the slide.
Preview the slideshow	Press  , and then tap More > Preview . Tap once on the preview screen to see playback controls.

3. When finished, tap **Send**, or press  to save the message as a draft.

Resuming a draft message

1. On the All messages screen, press , and then tap **Drafts**.
2. Tap the message and then resume editing it.
3. Tap **Send**.

Viewing and replying to a message

Depending on your notification settings, the phone plays a ringtone, vibrates, or displays the message briefly in the status bar when you receive a new message. A new message icon  is also displayed in the status bar.



1. To open and read the message, you can:
 - Press and hold the status bar, and then slide your finger down to open the Notifications panel. Then tap the new message notification.
 - Open the Messages app to access and read the message.
2. While reading the message, you can:

Reply with a text message	Tap the box that says Add text , enter your reply message, and then tap Send .
Reply with a multimedia message	Tap the box that says Add text , enter your reply message, tap  to choose an attachment for your message, and then tap Send .
Call or save a phone number contained in the message	Tap the phone number. Then choose whether to dial the number or add it to your contacts.
Open a link in the message	Tap the link to open it in the web browser.
Send to or save an email address contained in the message	Tap the email address. Then choose whether to send an email, send a multimedia message, or save the email address to your contacts.
Forward a message	Press and hold the message to open the options menu, and then tap Forward .
Check message details	Press and hold the message to open the options menu, and then tap View message details .

Replying to another phone number of the contact

When a contact has multiple phone numbers stored on your phone, you'll see the particular phone number used within the message. There's also a bold letter before the phone number to indicate the number type (for example, **M** stands for **Mobile**).

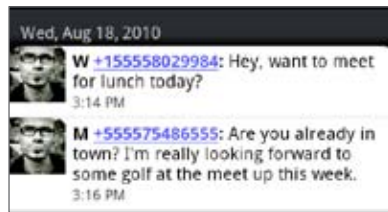

Keep in mind that your response will be sent to the phone number of the latest message you've received from this contact.

1. On the All messages screen, tap a contact (or phone number) to display the exchange of messages with that contact.
2. Tap the box that says **Add text**, then enter your reply message.
3. Press  and then tap **More > Recipient phone number**.
4. Select another phone number of this contact, and then tap **OK**.

Viewing and saving an attachment from a multimedia message

If you are concerned about the size of your data downloads, check the multimedia message size first before you download it.



When **Auto-retrieve** in MMS settings is disabled, only the message header is downloaded. To download the entire message, tap the **Download** button at the right side of the message.

- If there's a media attachment such as a photo or video in a received message, tap it to view the content.
- If the attachment is a contact (vCard), tap it to view the contact information, then tap **Save** to add to your contacts.
- If the attachment is an appointment or event (vCalendar), tap it to choose the calendar where to save it, and then tap **Import**.
- To save the attachment to your storage card, press and hold the multimedia message, and then choose to save the type of attachment from the options menu.

Push messages



Push messages contain a web link. Often, the link will be to download a file that you have requested, for example a ringtone.

When you receive a push message, a notification icon  is displayed in the status bar.

Opening and reading a new push message

1. Press and hold the status bar, and then slide the status bar down to open the Notifications panel.
2. Tap the new message.
3. Tap **Visit website**.

Viewing all your push messages

1. From the Home screen, tap  > **Messages**.
2. Press , and then tap **Push messages**.



You can only see this option if you've previously received push messages.

Managing message conversations

Protecting a message from deletion

You can lock a message so that it will not be deleted even if you delete the other messages in the conversation.

1. On the All messages screen, tap a contact (or phone number) to display the exchange of messages with that contact.
2. Press and hold the message that you want to lock.
3. Tap **Lock message** on the options menu. A lock icon  is displayed at the right hand side of the message.

Copying a message to your SIM card

1. On the All messages screen, tap a contact (or phone number) to display the exchange of messages with that contact.
2. Press and hold the message, and then tap **Copy to SIM**. A SIM card icon  is displayed at the right hand side of the message.

Deleting a single message

1. On the All messages screen, tap a contact (or phone number) to display the exchange of messages with that contact.
2. Press and hold the message that you want to delete.
3. If the message is locked, tap **Unlock message** on the options menu, and then press and hold the message to display the options menu again.
4. Tap **Delete message** on the options menu.
5. When prompted to confirm, tap **OK**.

Deleting several messages within a conversation

1. On the All messages screen, tap a contact (or phone number) to display the exchange of messages with that contact.
2. Press  and then tap **More > Delete**.
3. Tap **Delete by selection**.



You can also tap **Delete by phone number** if the contact used multiple phone numbers throughout the conversation and you want to delete the messages sent from a particular number.

4. Select the messages you want to delete and then tap **Delete**.

Deleting a conversation

1. Do any of the following:
 - On the All messages screen, press and hold a contact (or phone number) whose messages you want to delete, and then tap **Delete**.
 - While looking at the exchange of messages in a conversation, press  and then tap **More > Delete > Delete thread**.

Any locked messages in the conversation thread will not be deleted unless you select the **Delete locked messages** check box.
2. When prompted to confirm, tap **OK** to delete the entire thread.

Deleting several conversations

1. On the All messages screen, press  and then tap **Delete**.
2. Select the conversation threads you want to delete.
3. Tap **Delete**. Any locked messages will not be deleted.

Setting message options

On the All messages screen, press  and then tap **Settings**.

Notifications	<ul style="list-style-type: none"> ▪ Receive a notification in the status bar and set your phone to vibrate or play a sound when a message arrives or when a message is not sent successfully, and choose a notification sound. ▪ Allow your phone to show pop-up notifications on the screen when messages are sent successfully or not, or disable this option.
Text messages (SMS)	<ul style="list-style-type: none"> ▪ Receive a report on the delivery status of your message. ▪ View or change the message service center number used. (We recommend that you don't change the number here as it may cause problems in receiving and sending messages.) ▪ View or delete text messages stored on your SIM card, or copy SIM card messages to your phone's memory.
Multimedia messages (MMS)	<ul style="list-style-type: none"> ▪ Receive a report on the delivery status of your message. ▪ Receive a report whether each recipient has read the message or deleted it without reading. ▪ Automatically download complete MMS messages including the message body and attachments to your phone in your service area and when roaming. ▪ Set the message priority and maximum file size of MMS messages. If the MMS message file size is exceeded, the message won't be sent.
General	<ul style="list-style-type: none"> ▪ Search and display the sent message history, call history, and email addresses of stored contacts when you're adding message recipients. ▪ Choose the maximum number of text or MMS messages to store in each conversation thread (excluding locked messages), and enable automatic deletion of unlocked older messages when set limits are reached. ▪ Forward received text and MMS messages to another phone number or email address. (This may incur extra fees from your mobile operator.)

HTTC

People

Transferring contacts from your old phone

Easily transfer contacts from your old phone to your new HTC phone through Bluetooth. Depending on your old phone's model, you may also transfer other types of data such as calendar events and text messages to your new phone.

1. From the Home screen, tap  > **Transfer Data**.
2. Tap **Next** to begin.
3. Choose your old phone's name and model.
4. On your old phone, turn Bluetooth on and set it to discoverable mode.
5. On your new HTC phone, tap **Next** to continue. Your new phone automatically turns Bluetooth on and searches for Bluetooth devices.
6. From the device list, choose your old phone and then tap **Next**. Your new HTC phone then tries to pair with your old phone. You'll see a security passkey on the screen.
7. On your old phone, enter this passkey or simply confirm it.
8. Select the **Contacts** check box (and other supported types of data you want to import), and then tap **Next**.
9. When your new HTC phone finishes importing data, tap **Done**.



HTC

About the People app

With the People app, easily manage your communications with your contacts via phone, messaging, and email. You can also link your contacts to their social network accounts like Facebook and Twitter to see their updates and events from these accounts all in one place.

And that's not all. If you have the same contacts from different sources, People lets you merge their contact information so you won't have duplicated entries in your contacts list.

1. From the Home screen, tap  > People.
2. Tap one of the following tabs:

	All Gives you access to all contacts on your phone, online accounts, and more.
	Groups Lets you assign contacts to groups so you can easily send an SMS, MMS, or email message to a whole group.
	Call History Lists all your dialed numbers and received and missed calls.

HTC

Confidential



Your contacts list

The People app's All tab  shows all contacts on your phone and from the online accounts you're logged in to.

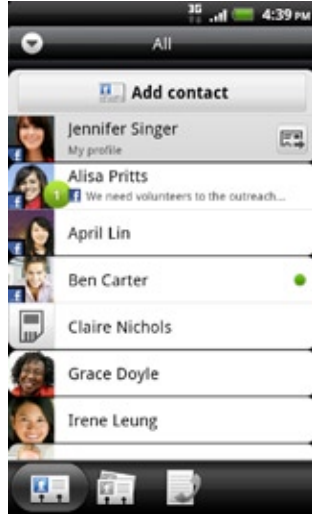
Your contacts list also displays the contacts stored on your SIM card (usually marked with the SIM card icon ).





From the All tab, you can:

- Open or update your contact information.
- Create, edit, or find contacts.
- View instant status updates when you've linked the contact to his or her social network account.
- Tap the contact's name to open the contact details screen for that contact.
- See a notification icon  when the contact has sent you a new message, tried to call you, updated his or her social network accounts, or when it's the contact's birthday.
- Check out who's online in Google Talk™. Online status icons are displayed if you're signed in to Google Talk on your phone. For example,  means the contact is available to chat.

Setting up your profile

Store your personal contact information in My profile to easily send it to other people.



1. From the Home screen, tap  > People.
2. On the All tab, tap Me.

 If you're logged in to your Facebook account through Facebook for HTC Sense, instead of Me, you'll see your Facebook name. Tap your name, press , then tap Edit.

3. Enter your name and contact details.
4. Tap Save.

Importing contacts from your SIM card

You can copy all your SIM contacts to your phone. Import them as phone contacts, Google contacts, or Exchange ActiveSync contacts, if you have set up the relevant accounts.

1. From the Home screen, tap  > People.
2. On the All tab, press , and then tap Import/Export > Import from SIM card.
3. If you have Google or Exchange ActiveSync accounts set up on your phone, tap the type for the imported contacts.
4. Do one of the following:
 - Tap one or more SIM contacts you want to import.
 - To import all contacts, press , and then tap Select all.
5. Tap Save.

Adding a new contact

1. From the Home screen, tap  > People.
2. On the All tab, tap Add contact.
3. Select the Contact type, for example Google or Microsoft® Exchange ActiveSync. This determines which account the contact will sync with.





Some fields may not be supported when you're adding contacts to your SIM card.

4. Tap the Name field, enter the first and last name of the contact, then tap OK.
5. Enter the contact information in the fields provided. Press  if you want to close the onscreen keyboard first and easily scroll through the other fields.
6. Tap Save.

Importing a contact from an Exchange ActiveSync account

You can search for a work contact from your Exchange ActiveSync account, and then copy it on your phone.

You need to have your Exchange ActiveSync account set up on your phone first.

1. From the Home screen, tap  > People.
2. Press , and then enter the name.
3. Tap . Under Company contacts, matching names are listed.
4. Tap the name of the contact you want copied on your phone, and then tap Save to People.

Merging contact information

If you have the same contacts on your phone, Google Account, and social network accounts such as Facebook and Twitter, your phone will try to combine them automatically or let you decide which contacts to combine. Combining the same contacts avoids duplicated entries in your contacts list.

Accepting matched contacts suggestions

When your phone finds contacts that can be merged, you'll see a link icon  in the notifications area of the status bar.

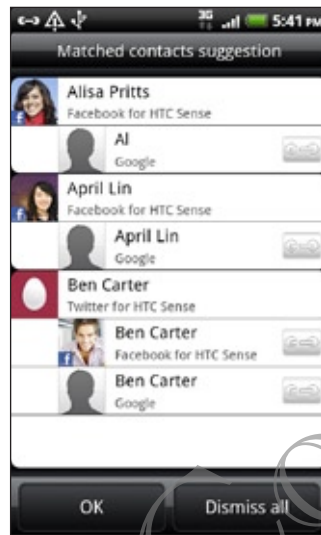

1. Slide the Notifications panel down, and then tap **Matched contacts suggestion**. Your phone displays all suggested contacts that you can merge.







2. To merge, tap .
3. Tap OK.

 If you don't want to merge any of your contacts, tap **Dismiss all**.



Viewing a list of all your linked contacts

1. From the Home screen, tap  > **People**.
2. On the All tab, press , and then tap **More > Linked contacts**. The All linked contacts screen then opens where you can see the account types and information merged.
3. You can choose to break the link of an account type or relink.
4. When you're done, tap OK.

Manually merging contact information



1. From the Home screen, tap  > People.
2. On the All tab, tap the name of the contact (not the icon or photo) you want to link.
3. On the upper-right corner of the screen, tap  or  (if there are suggested links).
4. On the screen, you can:
 - Under **Suggest links**, tap  to link the contact to an account.
 - Under **Add contact**, tap one of the options to link to another contact.
5. Tap Done.

Breaking the link



1. From the Home screen, tap  > People.
2. On the All tab, tap the name of the contact (not the icon or photo) whose link you want to break.
3. On the upper-right corner of the screen, tap .
4. Under the **Linked contacts** section, tap  beside an account type to break the link.
5. Tap Done.

Filtering your contacts list



After adding a new account to sync with your phone, you'll be asked whether to add contacts from that account the next time you open the People app. You can choose to only display contacts from particular account types (for example, Google contacts or Facebook contacts).

1. From the Home screen, tap  > People.
2. On the All tab, press , then tap View.
3. Select the types of contacts you want to show in your contacts list.
You can also choose how you want to display and sort your contacts.
4. Tap Done.

Searching for a contact

1. From the Home screen, tap  > People.
2. Press , then enter the first few letters of a contact's name. Matching contacts are displayed.
3. Tap the contact to open his or her contact details screen.

Backing up your contacts to the storage card

1. From the Home screen, tap  > People.
2. Press , and then tap Import/Export > Export to SD card.
3. Select an account or type of contacts to export, then tap OK.

Importing contacts from the storage card







You can only import contacts that were exported to the storage card using the **Export to SD card** feature on the phone.

1. From the Home screen, tap  > People.
2. Press , and then tap Import/Export > Import from SD card.
3. If you have Google or Exchange ActiveSync accounts set up on your phone, tap the type for the imported contacts.

Contact information and conversations

When you tap a contact on the People screen, the contact details screen opens, showing you the information you've stored or linked for that contact.

The contact details screen has the following tabs:

	<p>Details</p> <p>Shows the information you have stored for the contact. Get in touch with the contact directly by tapping any of the displayed methods. For example, if the contact has a stored work phone number, tap Call work.</p>
	<p>Messages</p> <p>Shows your exchanged SMS messages with the contact. You can reply to the contact's message directly from this tab.</p>
	<p>Mail</p> <p>Shows all the email you have received from the contact. Tap an email to view it.</p>
	<p>Updates and events</p> <p>Shows the contact's updates and events from social network accounts you've linked like Facebook, Twitter, and Flickr.</p>
	<p>Gallery</p> <p>Shows the linked contact's Facebook and Flickr albums and photos.</p>
	<p>Call History</p> <p>Lists all your incoming, outgoing, and missed calls to and from the contact.</p>

Editing a contact's information



1. From the Home screen, tap  > People.
2. On the All tab, press and hold the contact, and then tap **Edit contact**.



You cannot edit the contact information of a Facebook friend.

3. Enter the new information for the contact.
4. Tap **Save**.

Deleting contacts

1. From the Home screen, tap  > People.
2. On the All tab, press , and then tap **Delete**.
3. Select the contacts you want to remove, and then tap **Delete**.
4. When prompted, tap **OK**.

Sending contact information as a vCard

Easily share your own contact information or any contact on your phone.

1. From the Home screen, tap  > People.
2. On the All tab, do the following:

To send	Do this
Someone's contact information	Press and hold the name of the contact (not the icon or photo) whose contact information you want to send, and then tap Send contact as vCard .
Your contact information	<ol style="list-style-type: none"> 1. Tap [Your name] My profile. 2. Press , and then tap Send my profile.

3. Choose how you want to send it.

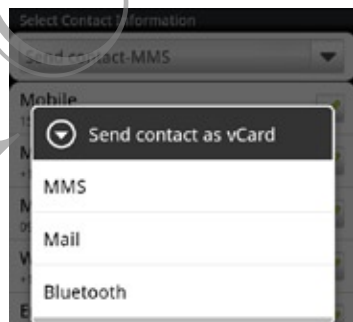

4. Select the type of information you want to send, and then tap **Send**.

Contact groups

Assign contacts to groups so you can easily send a message or email to a whole group. You can also sync groups on your phone with the groups in your Google account, accessible via your computer's web browser. We've also added the Frequent group as a special group type that automatically stores the contacts you dial or get calls from the most.

Creating a group



1. From the Home screen, tap  > People.
2. On the **Group** tab, tap **Add group**.
3. Enter a name for the group, and then tap **Add contact to group**.
4. Select the contacts you want to add to the group, and then tap **Save**.



If your contacts list is long, you can use the search bar to search for contacts quickly, or press  to hide the onscreen keyboard and scroll through the list.

5. Tap  to select a photo for the group.
6. Tap **Save**.

Editing a contact group

1. From the Home screen, tap  > People.
2. On the **Group** tab, press and hold the group, and then tap **Edit group**.
3. You can:
 - Tap the group name to change the name. You can only change the name for groups that you have created.
 - Tap the icon to the left of the group name to change or remove the group photo.
 - To add contacts to the group, tap **Add contact to group**, select the contacts you want to add, and then tap **Save**.
 - To remove a contact from the group, tap  at the right side of the contact name.
4. Tap **Save**.



Sending a message or email to a group



You will be charged by your mobile provider for each message sent. For example, if you send a message to a group of five people, you will be charged for five messages.

1. From the Home screen, tap  > People.
2. On the Group tab, tap the group you want to send a message or email to.
3. Go to the Group action tab, and then do one of the following:
 - Tap **Send group message** to send a message to the group.
 - Tap **Send group mail** to send an email to the group.



Rearranging your contact groups

1. From the Home screen, tap  > People.
2. On the Group tab, press , and then tap **Rearrange**.
3. Press and hold  at the end of the group you want to move. When the row is highlighted, drag it to its new position.



4. Tap **Save**.

Rearranging the members of a contact group

1. From the Home screen, tap  > People.
2. On the Group tab, tap the group to see its members.
3. Press , and then tap **Rearrange**.
4. Press and hold  at the end of the contact's name you want to move. When the row is highlighted, drag it to its new position.
5. Tap **Save**.

Deleting a group



You can only delete groups that you have created.

1. From the Home screen, tap  > People.
2. On the Group tab, press and hold the group you want to delete, and then tap **Delete group**.