

Consumer signal booster

user manual

Content

What is included	4
1 HOW IT WORKS	4
2 TOOL REQUIRED	4
3 HOW TO INSTALL YOUR NEW CELLULAR BOOSTER	5
3.1 Overview	5
3.2 Plan the layout of your system	7
3.3 Check for Signal Strength	7
3.4 Run coaxial cable	8
3.5 Install the Donor (Outdoor) antenna	9
3.6 Install the Server (Indoor) antenna	9
3.7 Install your cellular booster	10
3.8 Power up your cellular booster	10
3.9 Check the Cellular Booster Status	11
4 UNDERSTAND THE PORTS, MGC DIP SWITCH, LED STATUS	12
4.1 Repeater ports	12
4.2 Manual gain control (MGC)	12
4.3 LED status	13
5 UNDERSTAND THE ANTENNA	14
5.1 Donor (Outdoor) antenna	14
5.2 Server (Indoor) antenna	14

5.3	Antenna Kitting Options	Error! Bookmark not defined.
6	TROUBLESHOOTING	15
7	FREQUENTLY ASKED QUESTIONS	19
8	FCC RF Exposure Statement	20
9	Warning	21
10	Specification	21

WHAT IS INCLUDED

1. Booster F15G-CP
2. Outdoor Yagi 9dbi Antenna & 30' SIG5D Coaxial Cable
3. Indoor Panel 10dbi Antenna & 3' SIG5D Coaxial Cable
4. AC/DC Power Adapter

1 HOW IT WORKS

The cellular booster provides reliable two-way cellular coverage by improving signal strength in homes, buildings, offices, and other areas where cellular reception is weak or unreliable.

The system amplifies the signal from the nearest cellular tower and retransmits at a higher power level within a local area.

This manual provides simple installation instructions that will have your cellular booster kit running in record time.

2 TOOL REQUIRED



Phillips Screwdriver



Drill



Cellular Phone (to check signal strength)

3 HOW TO INSTALL YOUR NEW CELLULAR BOOSTER BOOSTER

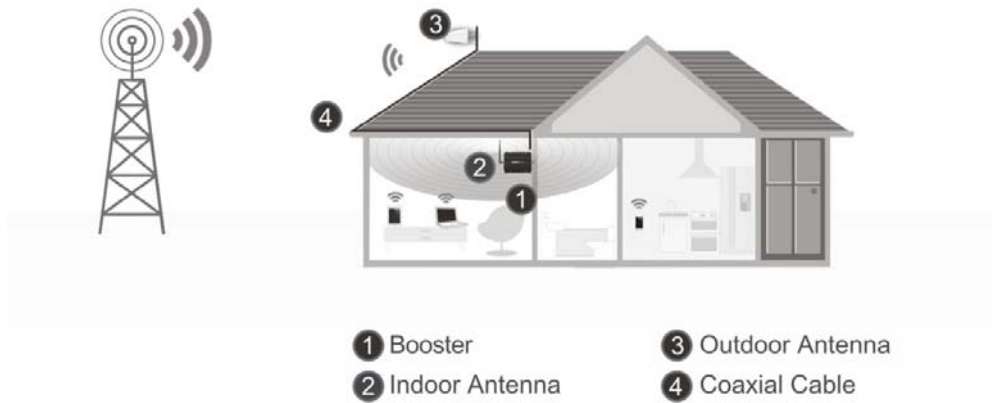

3.1 Overview

This guide will help you properly install your cellular booster kit. It is important to read through all of the installation steps before installing your equipment. Thoroughly read through the instructions, visualize where all the equipment will need to be installed and do a soft installation before mounting any equipment.

1

- **BOOSTER – select location**

- Install the booster in an area that is protected from the weather, properly ventilated and is away from excessive heat and moisture.

2

- **DONOR ANTENNA (OUTDOOR)- select location**

- Mount the signal (outdoor) antenna in an elevated outdoor location so that it points towards the cellular tower and away from where the inside antenna will be located.

3

- **OUTDOOR COAXIAL CABLE - select location**

- The outdoor coaxial cable is used to connect the donor (outdoor) antenna to the booster.

4

- **INDOOR COAXIAL CABLE- (if used)**

- The indoor coaxial cable is used to connect the server (indoor) antenna to the booster.

5

- **SERVER ANTENNA (indoor)**

- The ideal location for the distribution antenna will be the area of your property where you need to improve the signal most.
- **NOTE:** The signal strength will be strongest closest to the antenna.



- **IMPORTANT:** The signal antenna (outdoor) should always be separated from the distribution antenna (indoor) by at least 20 vertical feet including the separation of a thick barrier such as a roof or a wall. Depending on the strength of your outdoor signal, the weaker the signal the less separation distance is required.

7

- **LIGHTNING SURGE PROTECTOR- (SOLD SEPARATELY)**

- The lightning surge protector connects in between the signal antenna and the booster.
- **IMPORTANT:** Lightning surge protector must be grounded.

8

- **COMMISSIONING THE SYSTEM**



- 1 Donor Antenna (outdoor)
- 2 Surge Protector
- 3 Booster
- 4 Server Antenna (indoor)
- 5 Splitter (if using multiple antenna)
- 6 & 7 Server Antennas (optional antennas for additional coverage)

3.2 Plan the layout of your system

Before you get started you will need to plan the layout of your system. This involves checking signal strength for signals coming from the cellular tower, as well as antenna, booster and cable placement.

3.3 Check for Signal Strength

Select a location on the roof of the building to install the signal antenna, by monitoring your cellular phone's signal strength (signal bars) to find the strongest signal from your carrier's cellular tower.

Mark that area as the installation location for the Donor (outdoor)

IMPORTANT: Confirm that you have at least 20 feet of vertical distance between the marked antenna location and the location where you will place the Server (indoor) antenna. To prevent the system from oscillation

(feedback) you want to ensure that there is enough separation between the distribution and signal antenna or that they are shielded from each other to ensure the distribution antenna does not send a signal back into the signal antenna. If you cannot achieve these separations, either choose an alternate location for the donor (outdoor) antenna or determine if there are natural barriers in the building construction itself that will attenuate signals between the two antennas so that oscillation can be prevented.

3.4 Run coaxial cable

Loosely run the coaxial cable from your outdoor antenna to your booster. (After you have tested the system you can permanently secure the coaxial cable).

As you route and pull cabling, follow these general guidelines:

- Bend cables and route them smoothly, and protect the outer skin against any damage.
- Keep horizontal cables straight and fasten them with a tie every three to five feet.
- Bind and fasten vertical cables every six to eight feet.
- Waterproof all outdoor connections with silicone caulking
- Be careful when plugging the connector in so as not to damage the

center pins on the connectors.

3.5 Install the Donor (Outdoor) antenna

Connect the supplied coaxial cable to the antenna. We recommend applying silicone caulking to fully waterproof the connection.

Attach the cable in such a way that a drip loop is formed.

Once mounted, connect one end of the coaxial cable to the donor (outdoor) antenna and the other end to the cellular booster where it is marked “outdoor”

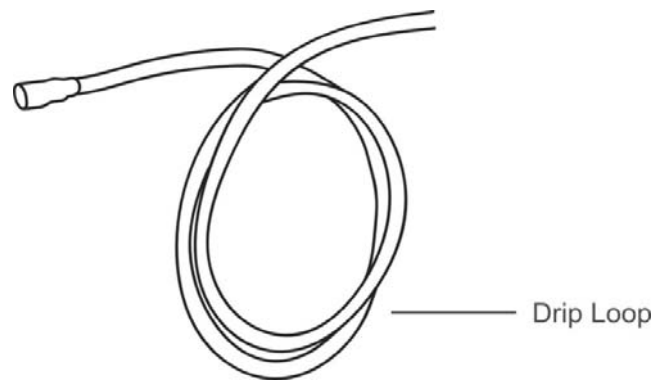

3.6 Install the Server (Indoor) antenna

Connect one end of the coaxial cable to the antenna and the other end to the cellular booster where it is marked “indoor”.

Select the installation location of your supplied server (outdoor) antenna based on the following:

Omni Ceiling directional antenna

Place in the center of the area where the signal needs to be amplified.

Panel directional antenna

Place in the outer perimeter of the area the signal needs to be amplified.

Whip Omni directional antenna

Mount directly to the connector marked “indoor” on the cellular booster.

3.7 Install your cellular booster

Install the cellular booster in a location that is properly ventilated and not exposed to excessive heat, moisture and/or direct sunlight. The optimal area would be on a wall located near a power outlet.

It should be mounted in an easily accessible area so it's easy to perform general maintenance with the coaxial cable connections, dip switch settings and power adaptor.

Make sure all cables and antennas are securely connected before commissioning the system.

3.8 Power up your cellular booster

Once all the Following precautions have been taken, power on the cellular booster.

1. Verify that you have left at least 20 feet of vertical separation space between the

- indoor and outdoor antennas.
2. Never point the front of the donor (outdoor) antenna towards the inside of the server (outdoor) antenna.
 3. Verify that the supplied coaxial cables from both the donor (outdoor) antenna and the server (outdoor) antenna are properly connected to the cellular booster before powering it up.
 4. Carefully plug in the supplied power adaptor into the back of the cellular booster where it is marked 'power' and connect the other end to a power outlet.

The LED indicator marked power should light up green.

3.9 Check the Cellular Booster Status

Your cellular booster comes equipped with electronic sensors designed to identify cellular signal overload or oscillation which can hinder signal boosting performance. Your cellular booster is specially designed to automatically decrease gain to compensate for these circumstances. The device also has a feature to automatically shut down in case of excessive oscillation. Improper equipment installation and unusable signal quality can cause oscillation, this is why it is important to fully understand the LED alarm lights on your booster, as they will help you identify and solve any potential issues.

The color of the LED indicates the status of the booster system.

4 UNDERSTAND THE PORTS, MGC DIP SWITCH, LED STATUS

4.1 Repeater ports

- 1) Outdoor port: connected with the donor antenna by cable.
- 2) Indoor port: connected with server antenna directly or by cable.
- 3) DC IN: connected with power supply.

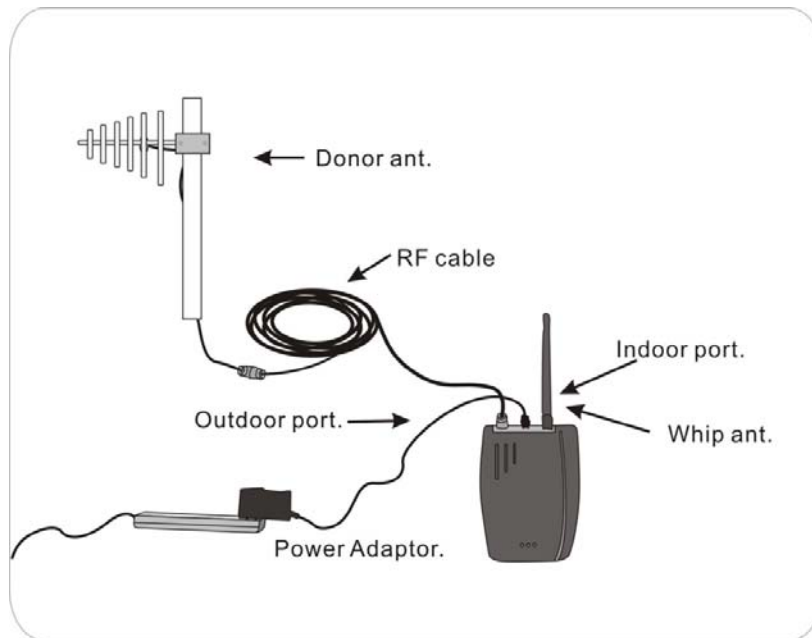

4.2 Manual gain control (MGC)

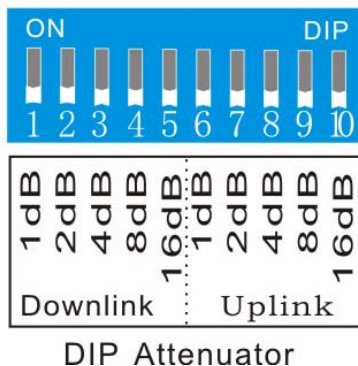

Switches 1-5 represent Downlink and 6-10 represent Uplink. When it is necessary to adjust the gain by DIP switch, firstly please adjust Downlink gain according to input signals, secondly please adjust Uplink gain according to Downlink gain.

The DIP Switches have default 'OFF' status; please push relevant switches to "ON" position if certain attenuation value needs to be achieved.

Att	1	2	3	4	5	Att.	1	2	3	4	5	Att.	1	2	3	4	5
0 dB	off	off	off	off	off	11dB	ON	ON	off	ON	off	22dB	off	ON	ON	off	ON
1 dB	ON	off	off	off	off	12dB	off	off	ON	ON	off	23dB	ON	ON	ON	off	ON
2 dB	off	ON	off	off	off	13dB	ON	off	ON	ON	off	24dB	off	off	off	ON	ON
3 dB	ON	ON	off	off	off	14dB	off	ON	ON	ON	off	25dB	ON	off	off	ON	ON
4 dB	off	off	ON	off	off	15dB	ON	ON	ON	ON	off	26dB	off	ON	off	ON	ON
5 dB	ON	off	ON	off	off	16dB	off	off	off	off	ON	27dB	ON	ON	off	ON	ON
6 dB	off	ON	ON	off	off	17dB	ON	off	off	off	ON	28dB	off	off	ON	ON	ON
7 dB	ON	ON	ON	off	off	18dB	off	ON	off	off	ON	29dB	ON	off	ON	ON	ON
8 dB	off	off	off	ON	off	19dB	ON	ON	off	off	ON	30dB	off	ON	ON	ON	ON
9 dB	ON	off	off	ON	off	20dB	off	off	ON	off	ON	31dB	ON	ON	ON	ON	ON
10 dB	off	ON	off	ON	off	21dB	ON	off	ON	off	ON						

4.3 LED status

1. Status and definition of POWER indicators:

Status	Definition
Green	Normal
Off	DC power problem

2. Status and Definition of ALARM indicators; Alarm LED only works for downlink signals

Status	ALARM
Green	It is working in linearity attention: Input signals may be not enough
Red	There are overloading or self-oscillation, strong input signals, measures shall be taken
Orange	It is working in linearity Attention: Please adjust MGC to increase the attenuation value, till you find the “edge point” (I.E. the Alarm LED shall stay at green color, with intention of turning Orange), and let the repeater work at this point.
Off	Repeater break down

5 UNDERSTAND THE ANTENNA

5.1 Donor (Outdoor) antenna



The Yagi Lpda Antenna

The yagi is a very precise directional antenna with a powerful reach. This antenna should be installed in an elevated position and must be pointed towards your carrier's cellular tower.

NOTE: This antenna is not meant to capture signal from multiple carriers.



The Panel Antenna

The panel is a directional antenna with a 120 degree reach and is designed to capture the signal from multiple carrier towers. This antenna should be installed in an elevated position and must be pointed towards your carrier's cellular towers.



Yagi Antenna

The yagi is a very precise directional antenna with a powerful reach. This antenna should be installed in an elevated position and must be pointed towards your carrier's cellular tower.

NOTE: This antenna can only support single band signal booster.

5.2 Server (Indoor) antenna



The Whip Antenna

The whip antenna is an omni-directional antenna with a 360 degree reach. It is designed to distribute the signal from the center of the affected area. Typically it is connected directly to the booster.



The Omni Antenna

The omni antenna is an omni-directional antenna with a 360 degree reach. It is designed to distribute the signal from the center of the affected area. Typically it is installed in a false or dropped ceiling.



The Panel Antenna

The panel is a directional antenna with a 120 degree reach and is designed to distribute the signal from a perimeter wall or ceiling.

5.1 Antenna Kitting Options

Outdoor Antenna & Cable Kit Options

1. Kit 11-3050
Outdoor Yagi 11dbi Antenna & 30' 5D Coaxial Cable
2. Kit 11-50400
Outdoor Yagi 11dbi Antenna & 50' 400 Coaxial Cable
3. Kit 11-5050
Outdoor Yagi 11dbi Antenna & 50' 5D Coaxial Cable
4. Kit 11-75400
Outdoor Yagi 11dbi Antenna & 75' 400 Coaxial Cable
5. Kit 11-100400
Outdoor Yagi 11dbi Antenna & 100' 400 Coaxial Cable
6. Kit 11-7550
Outdoor Yagi 11dbi Antenna & 11' 75 Coaxial Cable
7. Kit 11-10050
Outdoor Yagi 11dbi Antenna & 100' 50 Coaxial Cable
8. Kit 10-30400
Outdoor Panel 10dbi Antenna & 30' 400 Coaxial Cable
9. Kit 10-3050
Outdoor Panel 10dbi Antenna & 30' 5D Coaxial Cable
10. Kit 10-50400
Outdoor Panel 10dbi Antenna & 50' 400 Coaxial Cable
11. Kit 10-5050
Outdoor Panel 10dbi Antenna & 50' 5D Coaxial Cable
12. Kit 10-75400
Outdoor Panel 10dbi Antenna & 75' 400 Coaxial Cable
13. Kit 10-100400
Outdoor Panel 10dbi Antenna & 100' 400 Coaxial Cable
14. Kit 10-7550
Outdoor Panel 10dbi Antenna & 75' 5D Coaxial Cable
15. Kit 10-10050
Outdoor Panel 10dbi Antenna & 100' 5D Coaxial Cable
16. Kit 9-30400
Outdoor Yagi 9dbi Antenna & 30' 400 Coaxial Cable
17. Kit 9-3050
Outdoor Yagi 9dbi Antenna & 30' 5D Coaxial Cable
18. Kit 9-50400
Outdoor Yagi 9dbi Antenna & 50' 400 Coaxial Cable
19. Kit 9-5050
Outdoor Yagi 9dbi Antenna & 30' 5D Coaxial Cable
20. Kit 9-75400
Outdoor Yagi 9dbi Antenna & 75' 400 Coaxial Cable
21. Kit 9-100400
Outdoor Yagi 9dbi Antenna & 100' 400 Coaxial Cable
22. Kit 9-7550
Outdoor Yagi 9dbi Antenna & 75' 5D Coaxial Cable
23. Kit 9-10050
Outdoor Yagi 9dbi Antenna & 100' 5D Coaxial Cable
24. Kit 5-30400
Outdoor Omni 5dbi Antenna & 30' 400 Coaxial Cable
25. Kit 5-3050
Outdoor Omni 5dbi Antenna & 30' 5D Coaxial Cable
26. Kit 5-50400
Outdoor Omni 5dbi Antenna & 50' 400 Coaxial Cable

27. Kit 5-5050
Outdoor Omni 5dbi Antenna & 50' 5D Coaxial Cable
28. Kit 5-70400
Outdoor Omni 5dbi Antenna & 70' 400 Coaxial Cable
29. Kit 5-100400
Outdoor Omni 5dbi Antenna & 100' 400 Coaxial Cable
30. Kit 5-7550
Outdoor Omni 5dbi Antenna & 75' 50 Coaxial Cable
31. Kit 5-10050
Outdoor Omni 5dbi Antenna & 100' 5D Coaxial Cable

Indoor Antenna & Cable Kit Options

1. Kit 5-0
Indoor Whip 5dbi Antenna
2. Kit 100-1550
Indoor Panel 10dbi Antenna & 15' 5D Coaxial Cable
3. Kit 100-30400
Indoor Panel 10dbi Antenna & 30' 400 Coaxial Cable
4. Kit 100-5050
Indoor Panel 10dbi Antenna & 50' 5D Coaxial Cable
5. Kit 100-7550
Indoor Panel 10dbi Antenna & 75' 5D Coaxial Cable
6. Kit 102-7550-50
2 Indoor Panel 10dbi Antennas & 75' 5D Coaxial Cable & a 50 Ohm 2-ways Splitter
7. Kit 103-7550-75
3 Indoor Panel 10dbi Antennas & 75' 5D Coaxial Cable & a 75 Ohm 3-ways Splitter
8. Kit 104-7550-50
4 Indoor Panel 10dbi Antennas & 75' 5D Coaxial Cable & three 50 Ohm 2-ways Splitters
9. Kit 100-10050
Indoor Panel 10dbi Antenna & 100' 5D Coaxial Cable
10. Kit 100-30400
Indoor Panel 10dbi Antenna & 100' 400 Coaxial Cable
11. Kit 100-50400
Indoor Panel 10dbi Antenna & 50' 400 Coaxial Cable
12. Kit 100-75400
Indoor Panel 10dbi Antenna & 75' 400 Coaxial Cable
13. Kit 3-0350
Indoor Omni 3dbi Antenna & 3' 5D Coaxial Cable
14. Kit 3-1550
Indoor Omni 3dbi Antenna & 15' 5D Coaxial Cable
15. Kit 3-30400
Indoor Omni 3dbi Antenna & 30' 400 Coaxial Cable
16. Kit 3-5050
Indoor Omni 3dbi Antenna & 50' 5D Coaxial Cable
17. Kit 3-7550
Indoor Omni 3dbi Antenna & 75' 5D Coaxial Cable
18. Kit 3-10050
Indoor Omni 3dbi Antenna & 100' 5D Coaxial Cable
19. Kit 3-30400
Indoor Omni 3dbi Antenna & 30' 400 Coaxial Cable
20. Kit 3-50400
Indoor Omni 3dbi Antenna & 50' 400 Coaxial Cable
21. Kit 3-75400
Indoor Omni 3dbi Antenna & 75' 400 Coaxial Cable
22. Kit 3-100400
Indoor Omni 3dbi Antenna & 100' 400 Coaxial Cable

23. Kit 32-50400-50
2 Indoor Omni 3dbi Antennas & 50' 400 Coaxial Cable & a 50 Ohm 2-ways Splitter
24. Kit 33-50400-75
3 Indoor Omni 3dbi Antennas & 50' 400 Coaxial Cable & a 75 Ohm 3-ways Splitter
25. Kit 34-50400-50
4 Indoor Omni 3dbi Antennas & 50' 400 Coaxial Cable & three 50 Ohm 2-ways Splitters

6 TROUBLESHOOTING

The LED alarm lights represent the status of the booster on each frequency. When the lights are green the device is operating normally meaning that it is not experiencing any oscillation (feedback) and it is boosting the signal at maximum power. When the LED lights begin to change color from green to orange to red, it means that particular frequency is experiencing some oscillation (feedback).

If the oscillation is excessive the booster will shut down for that particular frequency. The booster will still work for the other frequency on a multi-band booster.

Oscillation is caused when the indoor (distribution) antenna sends a signal back into the outdoor (signal) antenna. Similar to a PA system, when the microphone gets too close to the speaker it causes feedback. This will occur if your antennas are too close together, or the indoor antenna is pointed at the outdoor antenna. Make sure you have adequate separation and some type of shielding between the antennas (Usually your roof or a cement wall is good enough).

IMPORTANT NOTES

The 2 most important things to look for when setting up your system is:

1

A good input signal (the best you can find)

2

Isolating the outdoor (donor) antenna from the indoor (server) antennas so they do not feedback into each other.

By capturing the best input signal you will be able to enjoy the maximum coverage and best quality signal inside where your Indoor antennas are located. The better the input signal, the better the output signal. In order to find the best input signal, you want to place your outdoor antenna as high as possible with the least amount of obstruction between the antenna and the cellular base tower. A clear line of site is ideal.

Isolating the signal from the antennas is done by ensuring that the antennas are not pointing to each other and by having enough distance or barrier shielding in between them. The signals travel like rays of sunlight, a directional antenna will send the signal in the direction that it is pointing. An omni directional antenna will send the signal in every direction around it. So depending on your equipment it's important to be sure that your Indoor antenna is not sending the signal back into the outdoor antenna.

THINGS TO CHECK WHEN EXPERIENCING WEAK CELLULAR SIGNAL

1. Ensure the outdoor antenna is pointing in the correct direction and is capturing adequate signal for the booster.
2. Check all connections on the cable, antennas, and booster.
3. Check cable for bends and or cuts.
4. All LED lights on the booster should be green.
5. Outdoor antenna and the indoor antennas have adequate separation and are not causing feedback.

7 FREQUENTLY ASKED QUESTIONS



WHY ARE THE LED LIGHTS TURNING ORANGE, RED OR SHUTTING OFF?

There are certain cases where your system could be experiencing oscillation. This can be attributed to either the quality of your input signal or having your outdoor antenna and indoor antenna too close together. Please review the following guidelines to help resolve this issue:

1. Adjust the direction of the outdoor antenna. If the system is receiving a very high input signal, you can point your outdoor antenna away from the cellular tower to reduce the strength of the input signal and therefore, reduce the oscillation. Alternatively if

your system is receiving a very poor quality signal (weak and unusable signal), you can point your outdoor antenna more directly towards the cellular tower to increase the strength of the input signal. Sometimes this may require completely repositioning the antenna to a location where you can achieve a line of site to the tower.

2. Increase the separation between the outdoor antenna and the indoor antenna. This can be achieved by increasing the distance between the two antennas or by placing barriers between them, such as moving the indoor antenna to an adjacent room where there would be an additional wall separating them from the outdoor antenna.
3. Manual Gain Control. Adjust the gain with the manual gain control function using the dip switches on the side of the booster.

8 FCC RF Exposure Statement

This equipment complies with FCC radiation exposure limits set forth for an uncontrolled environment. End users must follow the specific operating instruction for satisfying RF exposure compliance. This transmitter must not be co-located or operating in conjunction with any other antenna or transmitter.

9 Warning

This is a CONSUMER device

BEFORE USE, you MUST REGISTER THIS DEVICE with your wireless provider and have your provider's consent. Most wireless providers consent to the use of signal boosters. Some providers may not consent to the use of this device on their network. If you are unsure, contact your provider.

You MUST operate this device with approved antennas and cables as specified by the manufacture. Antenna MUST be installed at least 20cm (I inches) from any person.

You MUST cease operating this device immediately if requested by the FCC or a licensed wireless service provider.

WARNING. E911 location information may not be provided or may be inaccurate for calls served by using this device.

10 Specification

F15G-CP

Electrical specification		Uplink	Downlink
Frequency Range	Cell	824 ~ 849MHz	869 ~ 894MHz
	PCS	1850 ~ 1910MHz	1930 ~ 1990MHz
Band width	Cell	25 MHz	
	PCS	60 MHz	
Max .Gain	Cell	≤65dB	≤65dB
	PCS	≤67dB	≤67dB

Max .Output Power	Cell	23dBm	0dBm
	PCS	23dBm	0dBm
MGC (Step Attenuation)		31dB/1dBstep	
Automatic Level Control		≥ 15 dB, auto shut off after 15dB	
Inter-modulation	9KHz~12.75GHz	≤ -19 dBm	≤ -19 dBm
Spurious Emission	9KHz~12.75GHz	≤ -13 dBm	≤ -13 dBm
LED Alarm		Standard	
Power LED		Power Indicator	
ALC LED		Orange @ ALC 1~5dB, Red @ ALC 15dB	
		LED off after 5 seconds red color.	
Mechanical Specifications		Standard	
I/O Port		N-Female	
Impedance		50 ohm	
Operating Temperature		10°C~+55°C	
Environment Conditions		IP40	
Dimensions		120*135*43	
Weight		≤ 3 Kg	
Power Supply		Input AC90~264V,output DC12V / 3A	